

ENGINE MECHANICAL

SECTION **EM**

GI
MA
EM
LC
EC
FE
AT
PD
FA
RA
BR
ST
RS
BT
HA
EL
IDX

CONTENTS

PRECAUTIONS	2	THROTTLE BODIES	23
Parts Requiring Angular Tightening.....	2	Precaution.....	23
Liquid Gasket Application Procedure.....	2	Installation.....	23
PREPARATION	3	CYLINDER HEAD	25
Special Service Tools.....	3	Removal.....	26
Commercial Service Tools.....	5	Disassembly.....	27
OUTER COMPONENT PARTS	6	Inspection.....	28
COMPRESSION PRESSURE	8	Assembly.....	33
Measurement of Compression Pressure.....	8	Installation.....	34
OIL PAN	9	ENGINE REMOVAL	37
Removal.....	9	Removal.....	38
Installation.....	11	Installation.....	39
TIMING BELT	13	CYLINDER BLOCK	40
Removal.....	14	Disassembly.....	41
Inspection.....	16	Inspection.....	41
Installation.....	17	Assembly.....	49
OIL SEAL REPLACEMENT	21	SERVICE DATA AND SPECIFICATIONS (SDS)	52
		General Specifications.....	52
		Inspection and Adjustment.....	53

PRECAUTIONS

Parts Requiring Angular Tightening

- Use an angle wrench for the final tightening of the following engine parts:
 - (1) Cylinder head bolts
 - (2) Main bearing cap bolts
- Do not use a torque value for final tightening.
- The torque value for these parts are for a preliminary step.
- Ensure thread and seat surfaces are clean and coated with engine oil.

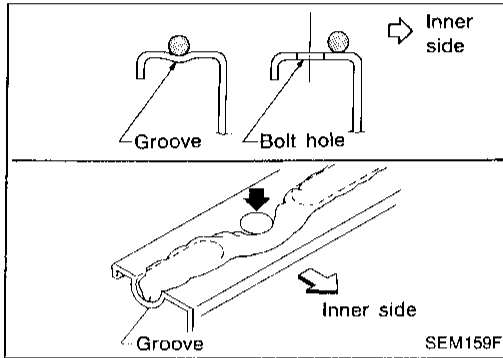

Liquid Gasket Application Procedure

- Use a scraper to remove all traces of old liquid gasket from mating surfaces and grooves. Also, completely clean any oil from these areas.**
- Apply a continuous bead of liquid gasket to mating surfaces. (Use Genuine Liquid Gasket or equivalent.)**
 - Be sure liquid gasket is 3.5 to 4.5 mm (0.138 to 0.177 in) wide (for oil pan).
 - Be sure liquid gasket is 2.0 to 3.0 mm (0.079 to 0.118 in) wide (in areas except oil pan).
- Apply liquid gasket around the inner side of bolt holes (unless otherwise specified).**
- Assembly should be done within 5 minutes after coating.**
- Wait at least 30 minutes before refilling engine oil and engine coolant.**

PREPARATION

Special Service Tools

The actual shapes of Kent-Moore tools may differ from those of special service tools illustrated here.

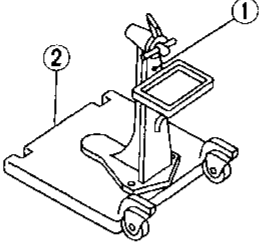
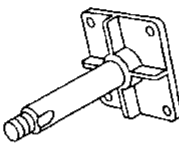
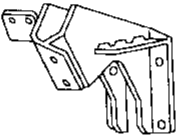
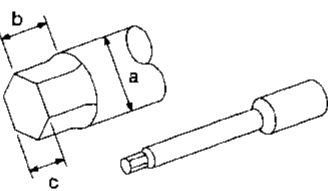
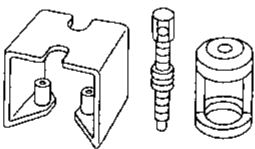
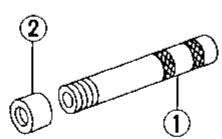
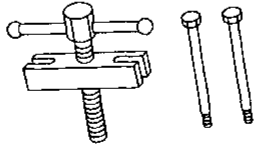
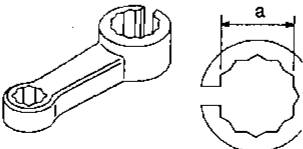
Tool number (Kent-Moore No.) Tool name	Description	
ST0501S000 (—) Engine stand assembly ① ST05011000 (—) Engine stand ② ST05012000 (—) Base		Disassembling and assembling NT042
KV10106500 (—) Engine stand shaft		NT028
KV10110001 (—) Engine sub- attachment		NT032
ST10120000 (J24239-01) Cylinder head bolt wrench		Loosening and tightening cylinder head bolt a: 13 mm (0.51 in) dia. b: 12 mm (0.47 in) c: 10 mm (0.39 in) NT583
KV10111300 (—) Valve spring compressor		Disassembling and assembling valve components NT017
① KV10107501 (—) Valve oil seal drift ② KV10111400 (—) Attachment		Installing valve oil seal NT026
ST27180001 (J25726-A) Steering wheel puller		Removing crankshaft pulley NT170
KV10114400 (J-38365) Heated oxygen sensor wrench		Loosening or tightening heated oxygen sensor a: 22 mm (0.87 in) NT636

GI

WA

EM

LC

EC

FE

AT

PD

FA

RA

BR

ST

RS

BT

HA

EL

IDX



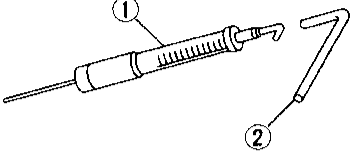
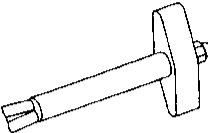
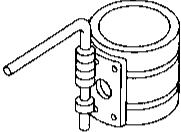
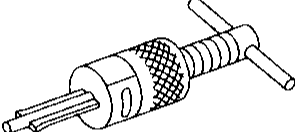
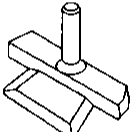
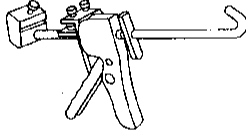
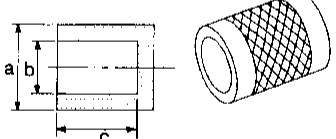
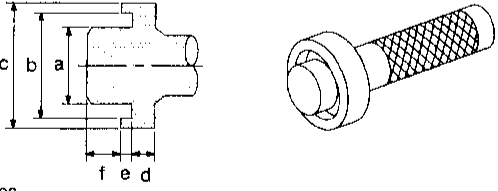
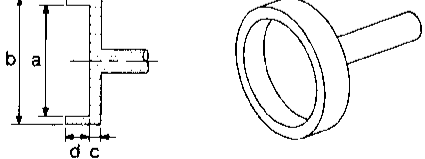

PREPARATION

Special Service Tools (Cont'd)

Tool number (Kent-Moore No.) Tool name	Description	
① EG14860000 (J-38387) Push-pull gauge ② KV10112000 (—) Hook		Adjusting timing belt tension
(J36467) Valve oil seal remover		Removing valve oil seals
EM03470000 (J8037) Piston ring compressor		Installing piston assembly into cylinder bore
ST16610001 (J23907) Pilot bushing puller		Removing crankshaft pilot bushing
KV10111100 (J37228) Seal cutter		Removing oil pan
WS39930000 (—) Tube presser		Pressing the tube of liquid gasket
ST33200000 (J26082) Drift		Installing camshaft oil seal a: 60 mm (2.36 in) dia. b: 44.5 mm (1.752 in) dia. c: 75 mm (2.95 in)
KV38100300 (J22888) Drift		Installing front oil seal a: 54 mm (2.13 in) dia. b: 46 mm (1.81 in) dia. c: 32 mm (1.26 in) dia. d: 15 mm (0.59 in) e: 5 mm (0.20 in) f: 10 mm (0.39 in)
ST15310000 (J25640-B) Drift		Installing rear oil seal a: 84 mm (3.31 in) dia. b: 96 mm (3.78 in) dia. c: 8 mm (0.31 in) d: 20 mm (0.79 in)

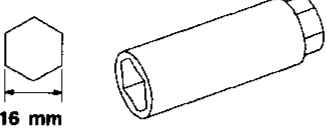
PREPARATION

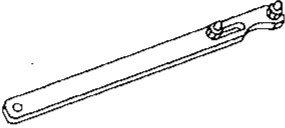
Commercial Service Tools

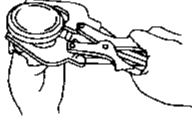
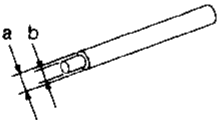
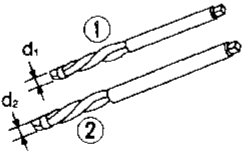
Tool name	Description
Spark plug wrench	<div style="display: flex; justify-content: space-between;"> <div style="text-align: center;">  <p>16 mm (0.63 in)</p> </div> <div style="text-align: center;">  </div> </div> <p>NT047</p> <p style="text-align: right;">Removing and installing spark plug</p>
Pulley holder	<div style="text-align: center;">  </div> <p>NT035</p> <p style="text-align: right;">Holding camshaft pulley while tightening or loosening camshaft bolt</p>
Valve seat cutter set	<div style="text-align: center;">  </div> <p>NT048</p> <p style="text-align: right;">Finishing valve seat dimensions</p>
Piston ring expander	<div style="text-align: center;">  </div> <p>NT030</p> <p style="text-align: right;">Removing and installing piston ring</p>
Valve guide drift	<div style="text-align: center;">  </div> <p>NT015</p> <p style="text-align: right;">Removing and installing valve guide</p> <p>Intake & Exhaust: a = 9.5 mm (0.374 in) dia. b = 5.5 mm (0.217 in) dia.</p>
Valve guide reamer	<div style="text-align: center;">  </div> <p>NT016</p> <p style="text-align: right;">Reaming valve guide ① or hole for oversize valve guide ②</p> <p>d₁ = 6.0 mm (0.236 in) dia. d₂ = 10.2 mm (0.402 in) dia.</p>

GI

MA

EM

LC

EC

FE

AT

PD

FA

RA

BR

ST

RS

BT

HA

EL

IDX

OUTER COMPONENT PARTS

SEC. 140-147-226-231 To intake manifold collector

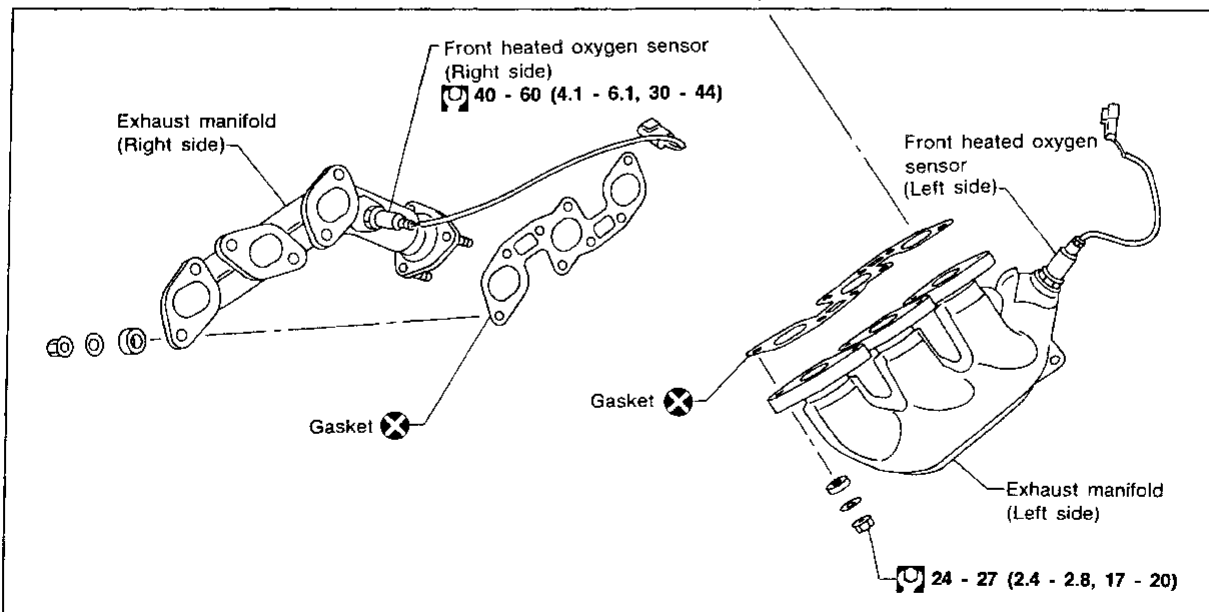
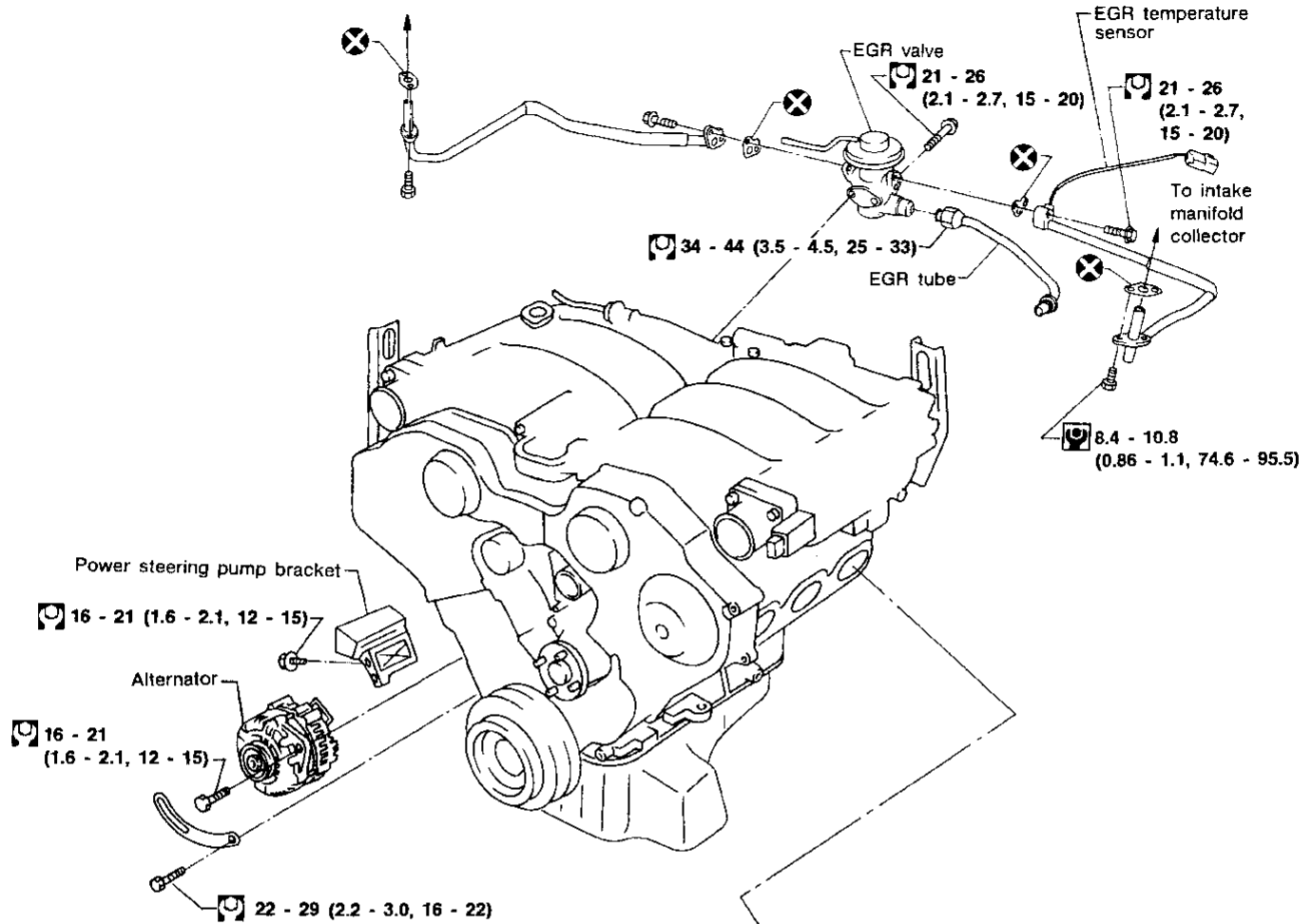

⊗ : N·m (kg-m, in-lb)
 ⊙ : N·m (kg-m, ft-lb)

OUTER COMPONENT PARTS

SEC. 140•148•163•164

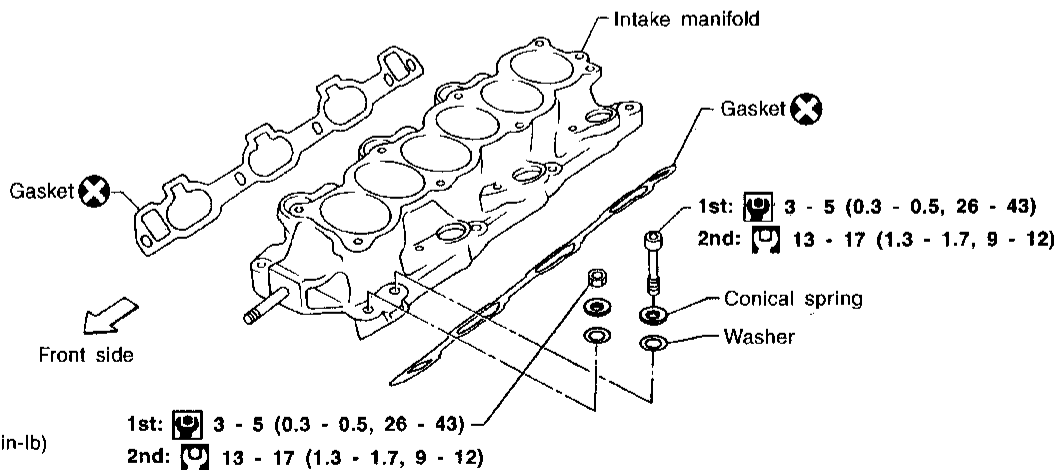
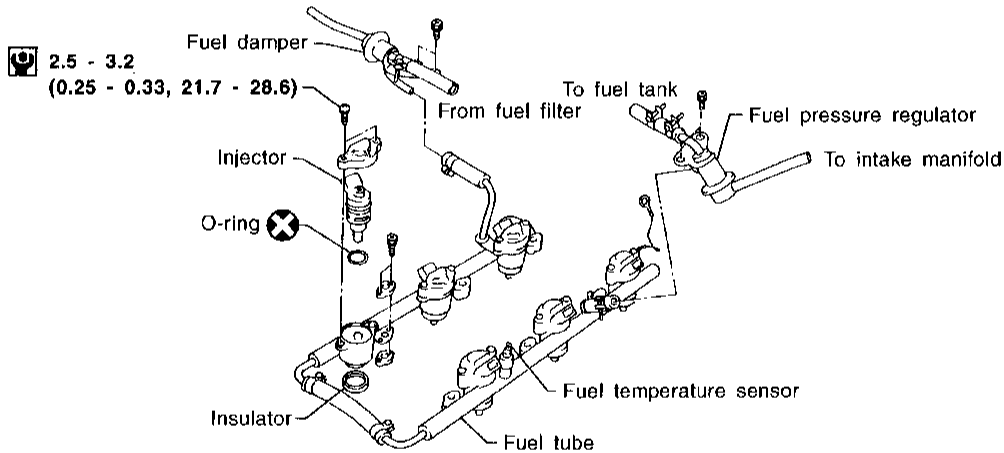
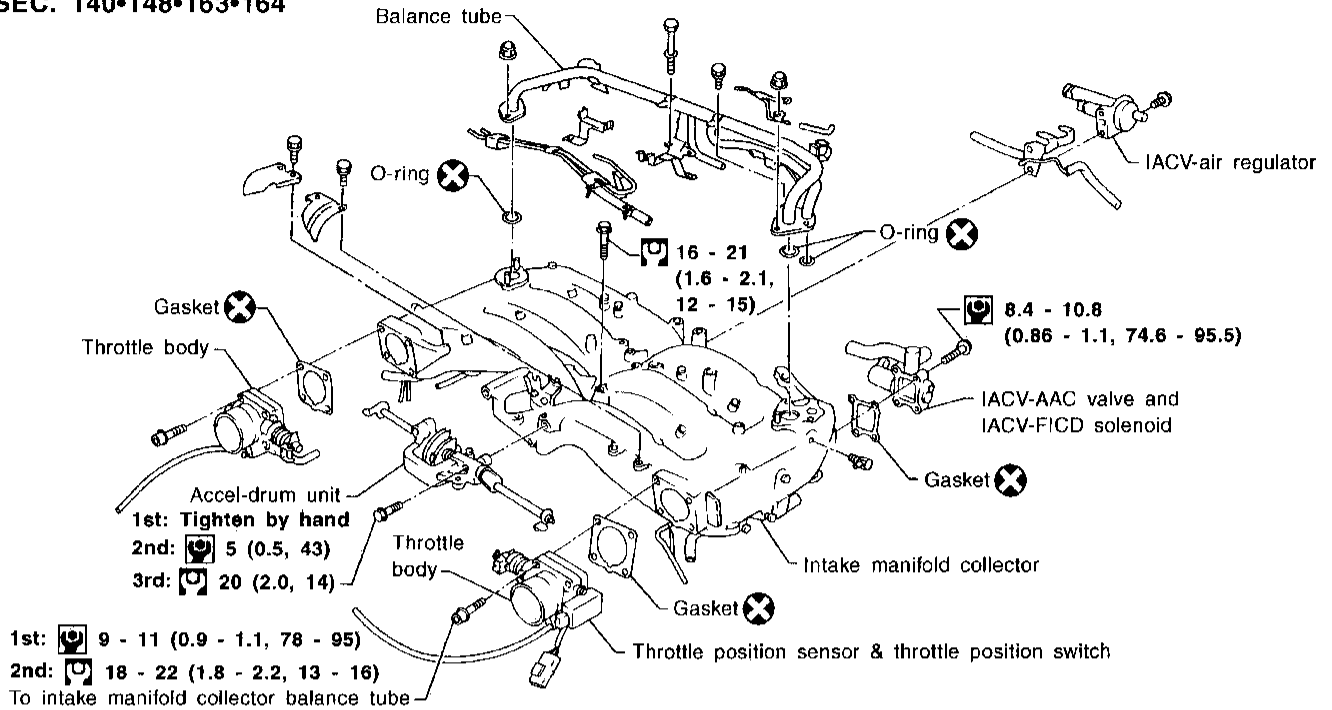

: N•m (kg-m, in-lb)
 : N•m (kg-m, ft-lb)

GI

MA

EM

LC

EC

FE

AT

PD

FA

RA

BR

ST

RS

BT

HA

EL

IDX

COMPRESSION PRESSURE

Measurement of Compression Pressure

1. Warm up engine.
2. Turn ignition switch off.
3. Release fuel pressure.
Refer to EC section ("Fuel Pressure Release", "BASIC SERVICE PROCEDURE").
4. Remove all spark plugs.
5. Disconnect camshaft position sensor harness connector.

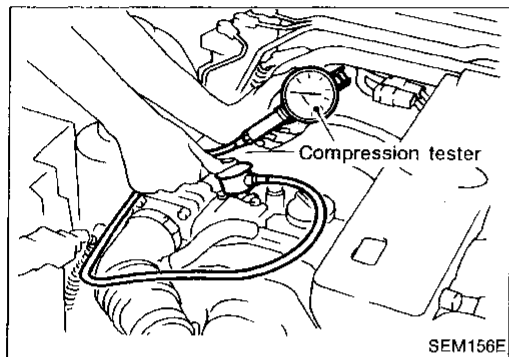

6. Attach a compression tester to No. 1 cylinder.
7. Depress accelerator pedal fully to keep throttle valve wide open.
8. Crank engine and record highest gauge indication.
9. Repeat the measurement on each cylinder as shown.

Always use a fully-charged battery to obtain specified engine speed.

Compression pressure:

Unit: kPa (kg/cm², psi)/300 rpm

Standard	1,285 (13.1, 186)
Minimum	981 (10.0, 142)
Differential limit between cylinders	98 (1.0, 14)

10. If compression in one or more cylinders is low:
 - a. Pour a small amount of engine oil into cylinders through spark plug holes.
 - b. Re-test compression.
 - **If adding oil helps compression, piston rings may be worn or damaged. If so, replace piston rings after checking piston.**
 - **If pressure stays low, a valve may be sticking or seating improperly. Inspect and repair valves and valve seats. Refer to SDS (EM-53). If valves or valve seats are damaged excessively, replace them.**
 - **If compression stays low in two cylinders that are next to each other:**
 - a. The cylinder head gasket may be leaking, or
 - b. Both cylinders may have valve component damage. Inspect and repair as necessary.

OIL PAN

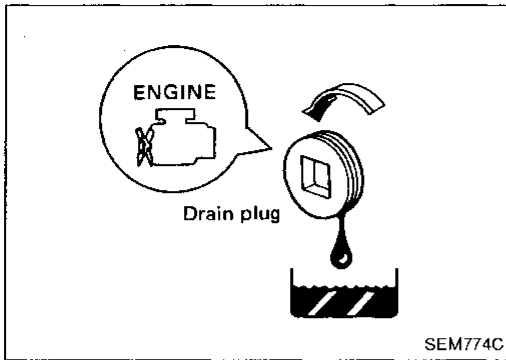

Removal

1. Drain engine oil.
2. Drain coolant from radiator drain cock.
3. Remove engine under cover.

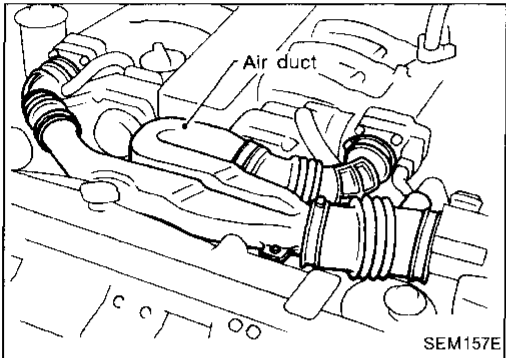

4. Remove air ducts.
5. Remove lower and upper radiator shrouds.

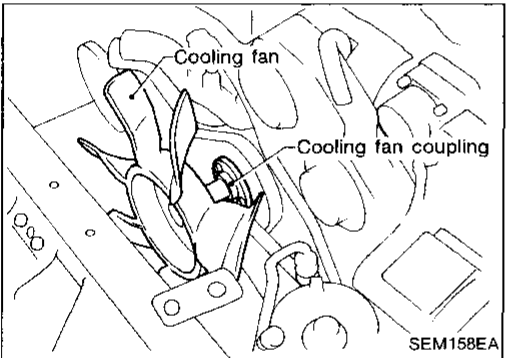

6. Remove cooling fan coupling.

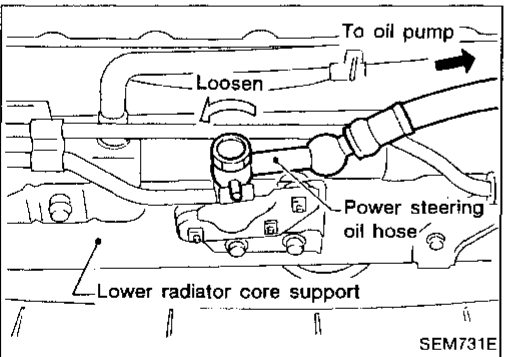

7. Disconnect power steering oil hoses.
8. Remove power steering oil pump.

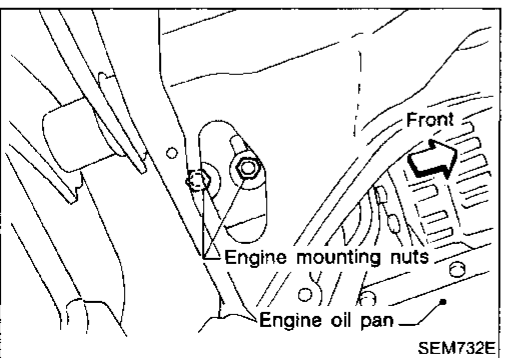

9. Remove engine mounting insulator lower fixing nuts from both sides.

GI

MA

EM

LC

EC

FE

AT

PD

FA

RA

BR

ST

RS

BT

HA

EL

IDX

OIL PAN

Removal (Cont'd)

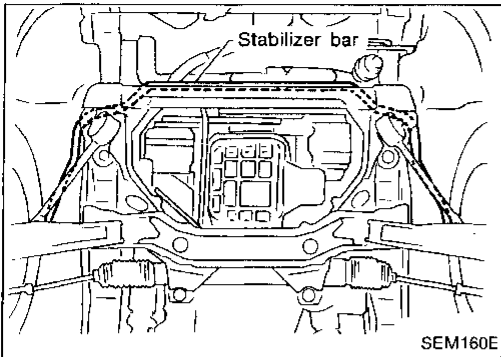

10. Remove stabilizer bar.
11. Hoist engine with engine slingers.
12. Remove oil pan bolts.

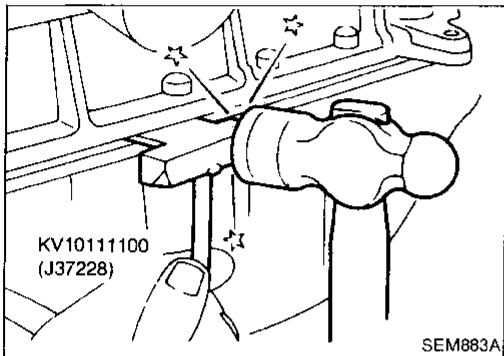

13. Remove oil pan.
 - a. Insert Tool between cylinder block and oil pan.
 - Do not drive seal cutter into oil pump or rear oil seal retainer, as aluminum mating surfaces may be damaged.
 - Do not insert screwdriver, or oil pan flange may be deformed.

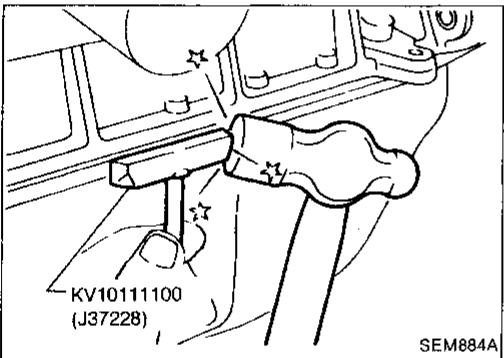

- b. Slide Tool by tapping its side with a hammer, and remove oil pan.

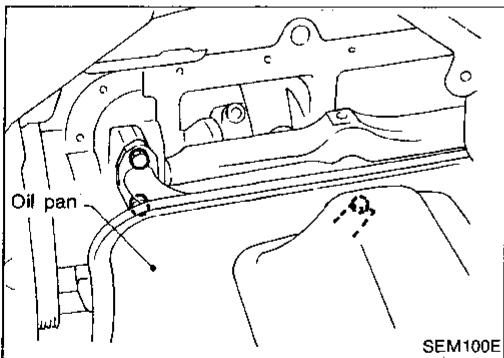

- c. Remove oil strainer.

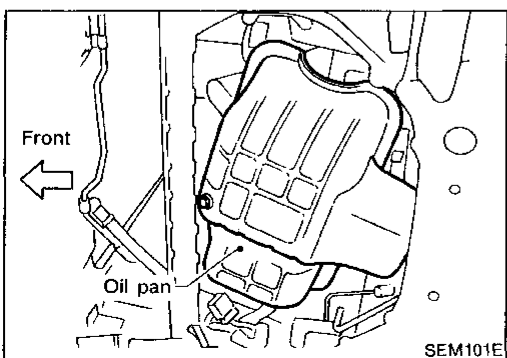

- d. Take out oil pan.

OIL PAN

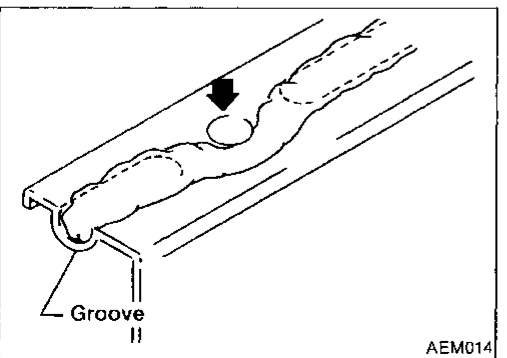
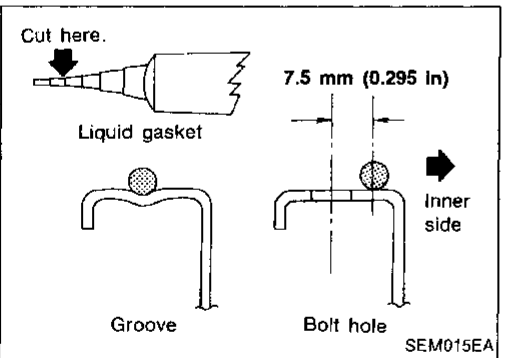
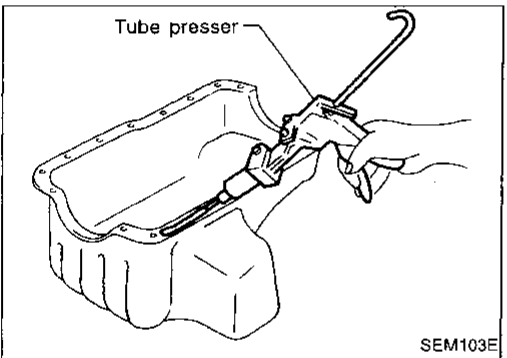
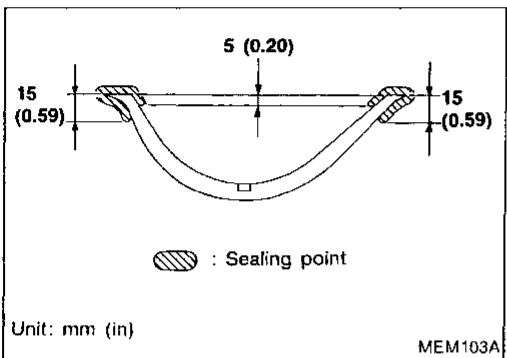
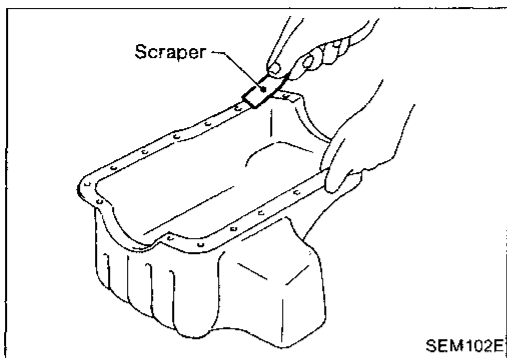

Installation

1. Before installing oil pan, remove all traces of liquid gasket from mating surface using a scraper.
 - Remove traces of liquid gasket from mating surface of cylinder block.
 - Also remove traces of old liquid gasket from the bolt holes and bolt threads.

GI

MA

EM

2. Apply sealant to oil pump gasket and rear oil seal retainer gasket.

LC

EC

FE

AT

3. Apply a continuous bead of liquid gasket to oil pan mating surface.

PD

Use Genuine Liquid Gasket or equivalent.

FA

RA

BR

- Be sure liquid gasket is 3.5 to 4.5 mm (0.138 to 0.177 in) wide.

ST

RS

BT

HA

4. Apply liquid gasket to inner sealing surface as shown in figure.

EL

- **Attaching should be done within 5 minutes after coating.**

IDX

OIL PAN

Installation (Cont'd)

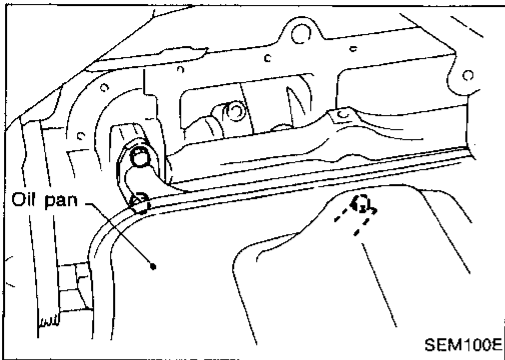

5. Put oil pan under the engine.
6. Install oil strainer.

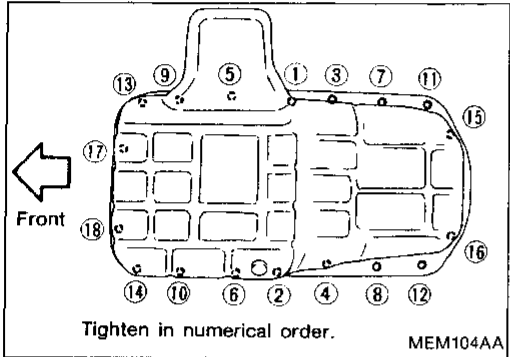

7. Install oil pan.
 - Install bolts in the reverse order of removal.
 - Wait at least 30 minutes before refilling engine oil.
 - Tightening procedure
 - ① - ⑫ :
16 - 21 N·m (1.6 - 2.1 kg-m, 12 - 15 ft-lb)
 - ⑬ - ⑱ :
6.3 - 8.3 N·m (0.64 - 0.85 kg-m, 55.6 - 73.8 in-lb)

TIMING BELT

CAUTION:

- Do not bend or twist timing belt.
- After removing timing belt, do not turn crankshaft and camshaft separately because valves will strike piston heads.
- Make sure that timing belt, camshaft sprocket, crankshaft sprocket, idler pulley and auto-tensioner are clean and free of oil and water.
- Timing belt installation should be carried out when engine is cold.

GI

MA

EM

LC

EC

FE

AT

PD

FA

RA

BR

ST

RS

BT

HA

EL

IDX

SEC. 120•130•135•221

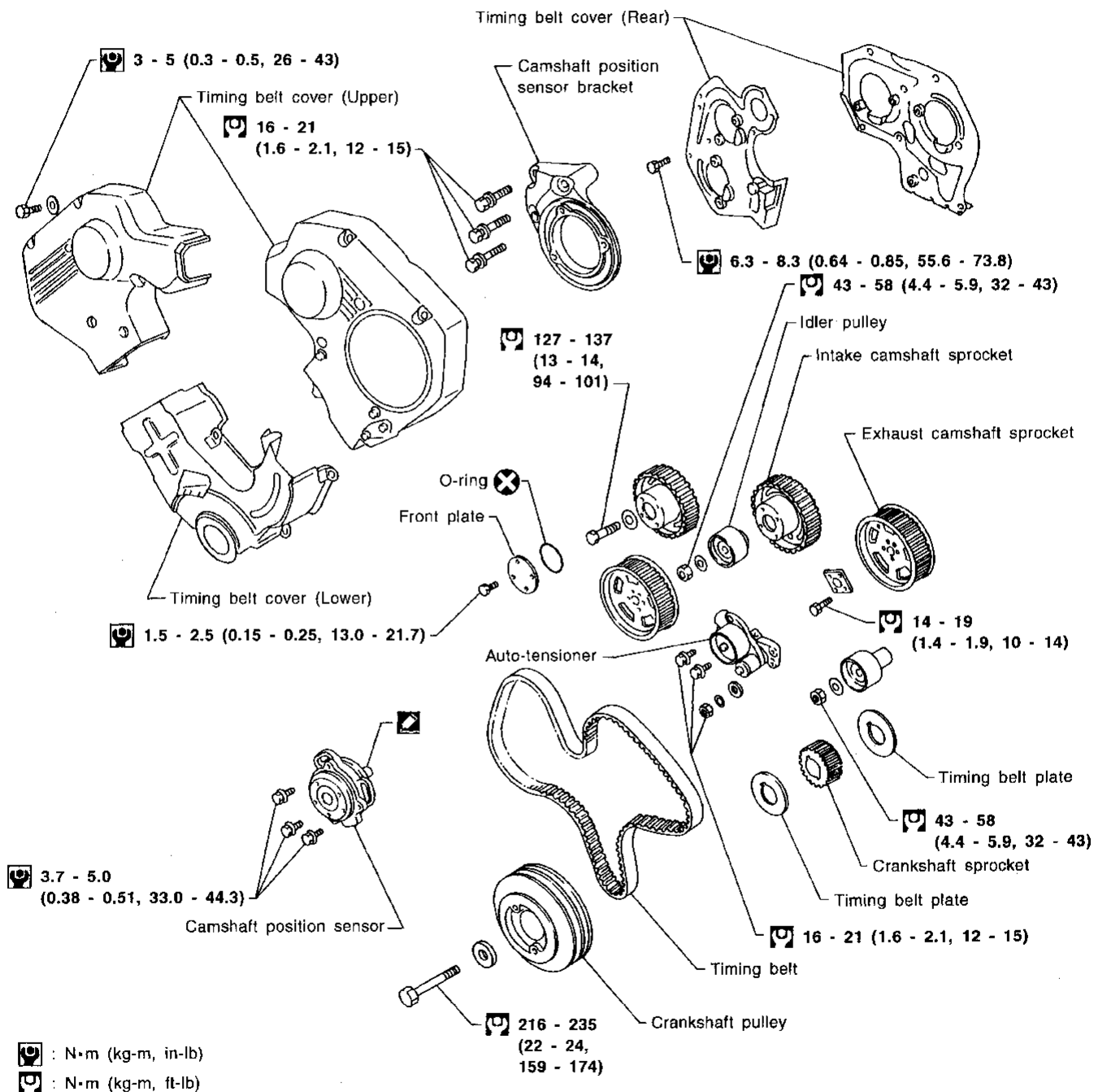

TIMING BELT

Removal

1. Remove engine under cover.
2. Drain coolant from both cylinder block drain plugs, and radiator drain cock.

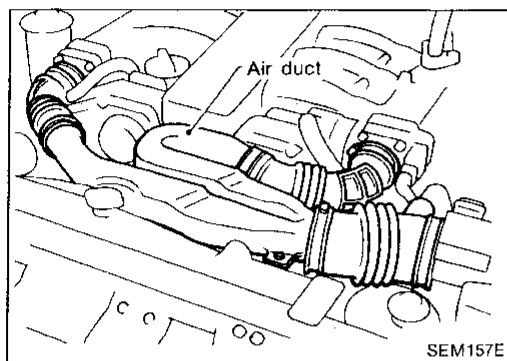

3. Remove air ducts.

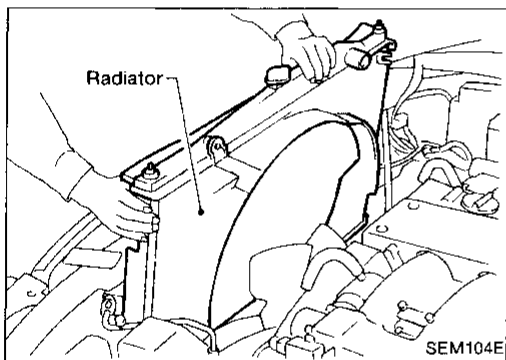

4. Remove radiator.
5. Remove drive belts, cooling fan and coupling.

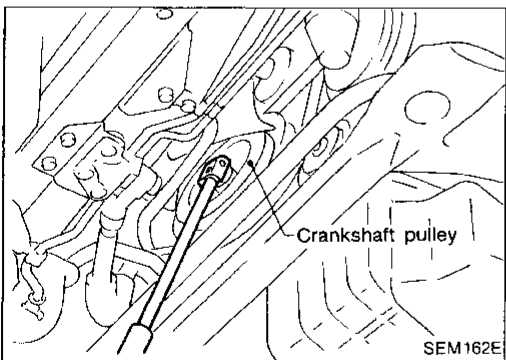

6. Remove crankshaft pulley bolt.
(At this time, remove starter motor and set a suitable tool to ring gear so that crankshaft cannot rotate.)

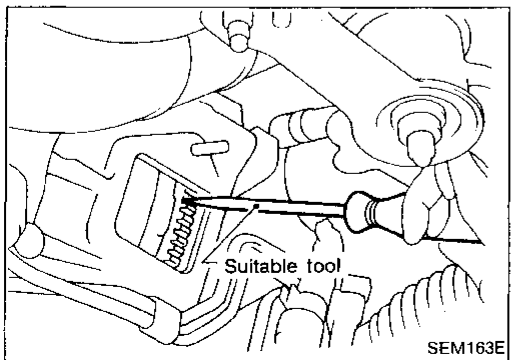

TIMING BELT

Removal (Cont'd)

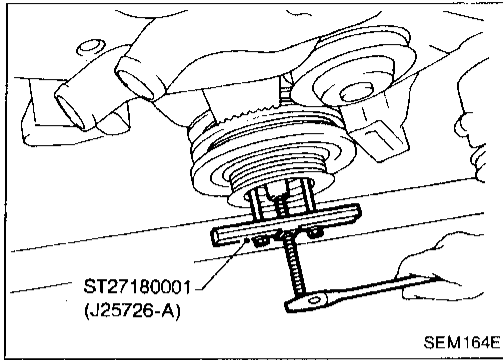

7. Remove crankshaft pulley using Tool.

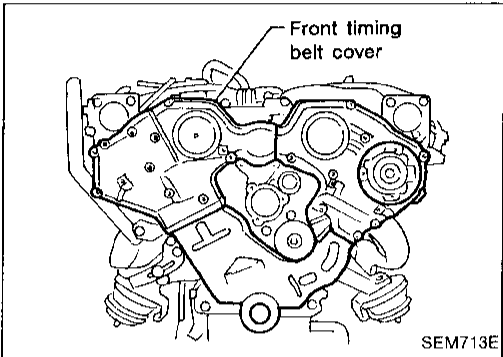

8. Remove water inlet and outlet. Refer to LC section ("Thermostat").
9. Remove front timing belt covers.

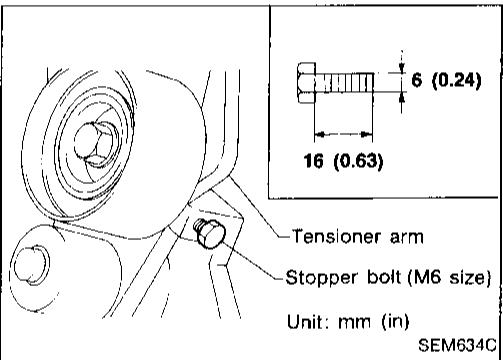

10. Install a suitable stopper bolt (M6) into tensioner arm of auto-tensioner so that auto-tensioner pusher does not spread out.

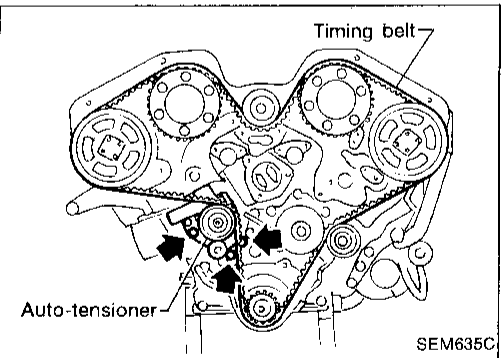

11. Set No. 1 cylinder at TDC on its compression stroke.
12. Remove auto-tensioner and timing belt.

GF

WA

EM

LC

EC

FE

AT

PD

FA

RA

BR

ST

RS

BT

HA

EL

IDX

TIMING BELT

Inspection

Visually check the condition of timing belt. Replace if any abnormality is found.

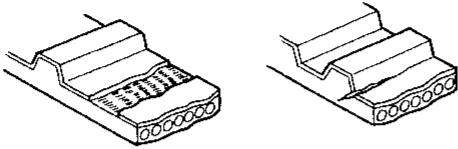
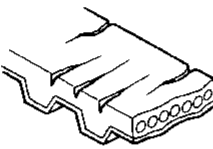
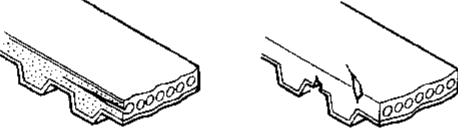
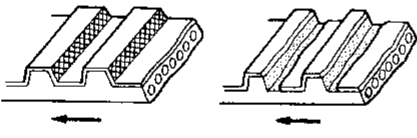
Item to check	Problem	Cause
Tooth is broken/tooth root is cracked.	 <p style="text-align: right;">SEM394A</p>	<ul style="list-style-type: none"> ● Camshaft jamming ● Distributor jamming ● Damaged camshaft/crankshaft oil seal
Back surface is cracked/worn.	 <p style="text-align: right;">SEM395A</p>	<ul style="list-style-type: none"> ● Tensioner jamming ● Overheated engine ● Interference with belt cover
Side surface is worn.	 <ul style="list-style-type: none"> ● Belt corners are worn and round. ● Wicks are frayed and coming out. <p style="text-align: right;">SEM396A</p>	<ul style="list-style-type: none"> ● Improper installation of belt ● Malfunctioning crankshaft pulley plate/timing belt plate
Teeth are worn.	 <p style="text-align: center;">Rotating direction</p> <ul style="list-style-type: none"> ● Canvas on tooth face is worn down. ● Canvas on tooth is fluffy, rubber layer is worn down and faded white, or weft is worn down and invisible. <p style="text-align: right;">SEM397A</p>	<ul style="list-style-type: none"> ● Poor belt cover sealing ● Coolant leakage at water pump ● Camshaft not functioning properly ● Distributor not functioning properly ● Excessive belt tension
Oil/Coolant or water is stuck to belt.		<ul style="list-style-type: none"> ● Poor oil sealing ● Coolant leakage at water pump ● Poor belt cover sealing

TIMING BELT

Inspection (Cont'd)

AUTO-TENSIONER

Check for oil leaks from pusher rod and diaphragm.

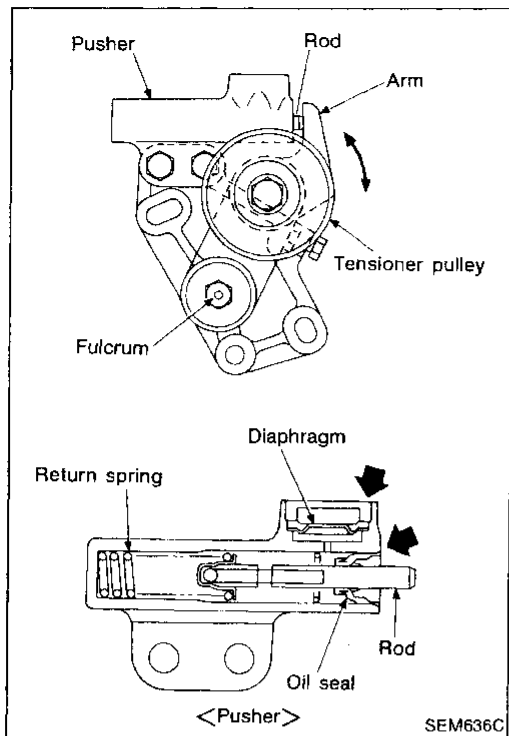

Installation

1. Confirm that No. 1 cylinder is set at TDC on its compression stroke.
2. Align matching marks on camshaft and crankshaft sprockets with aligning marks on rear belt cover and oil pump housing.
3. Remove all spark plugs.

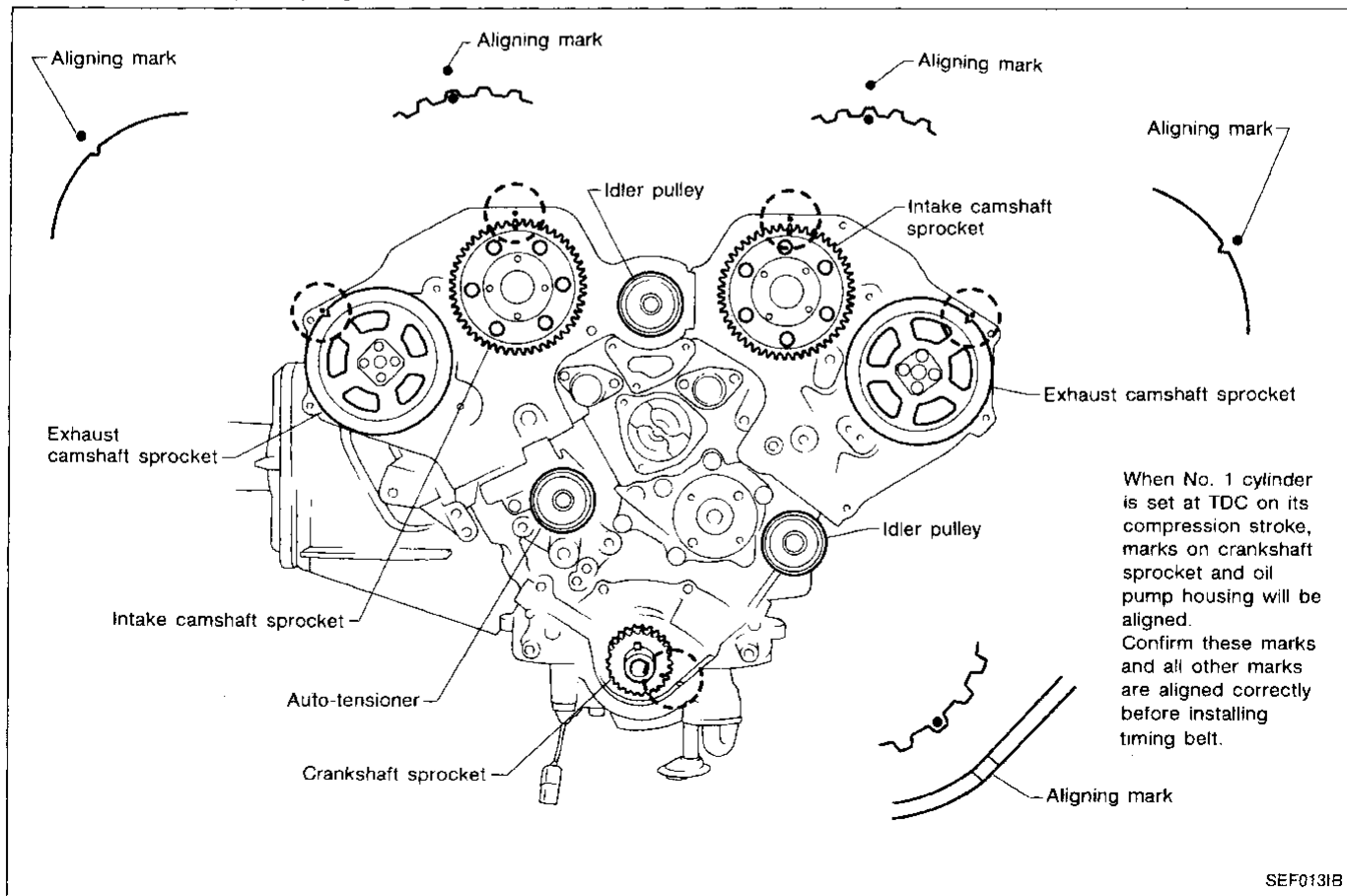

SEF0131B

TIMING BELT

Installation (Cont'd)

4. Set timing belt.
 - a. Ensure timing belt and sprockets are clean and free from oil or water. Do not bend or twist timing belt.
 - b. Align white lines on timing belt with matching mark on camshaft sprocket and crankshaft sprocket.
 - c. Point arrow on timing belt towards the front.

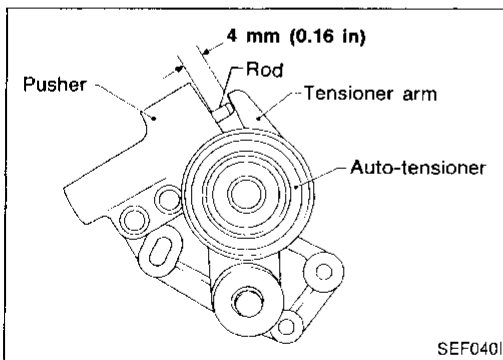
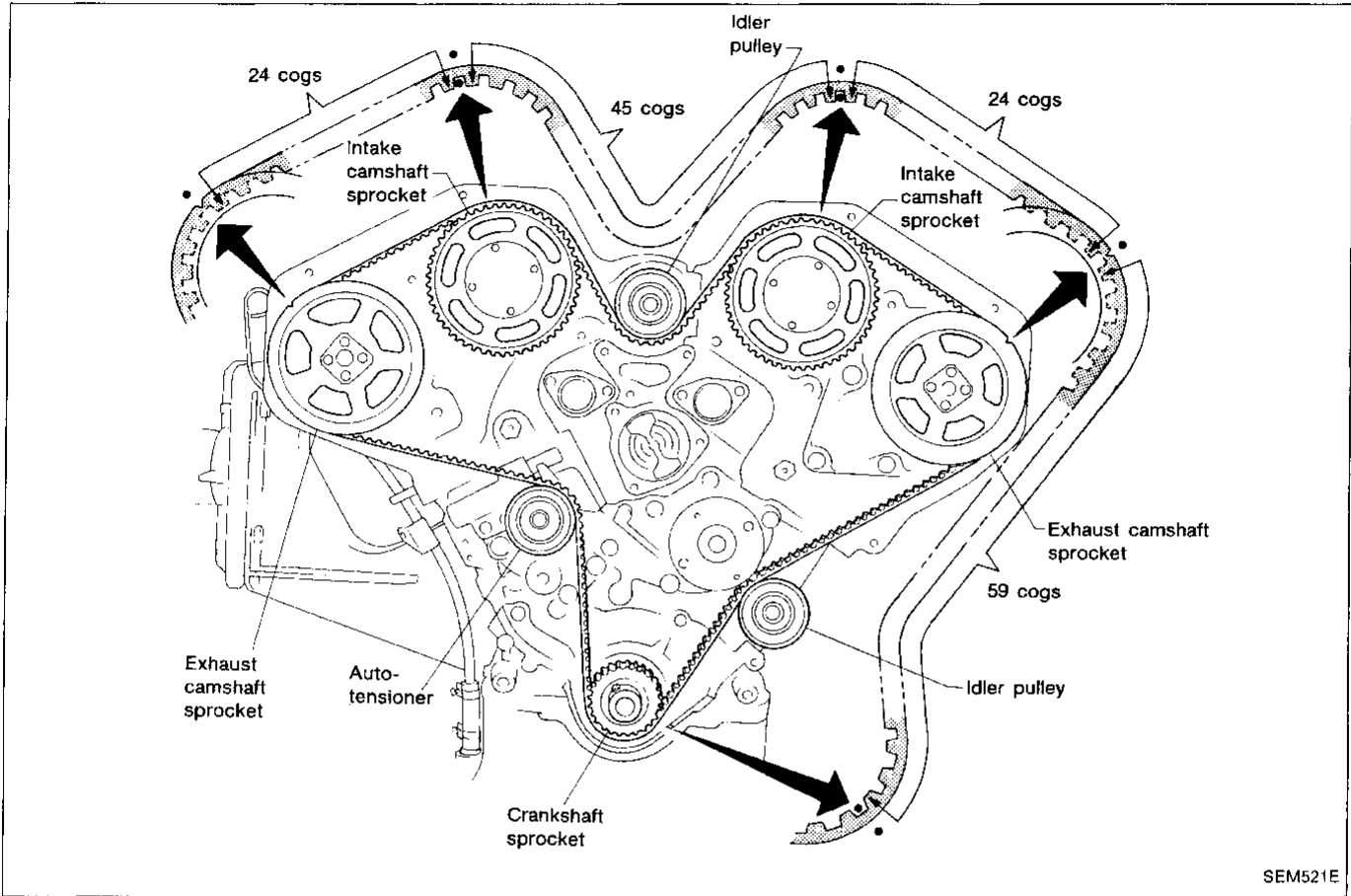

5. Use a vise to secure 4 mm (0.16 in) clearance between tensioner arm and pusher of auto-tensioner. Insert stopper bolt into tensioner arm to maintain this clearance.

When adjusting clearance, do not push tensioner arm with stopper bolt fitted because it will damage thread portion of stopper bolt.

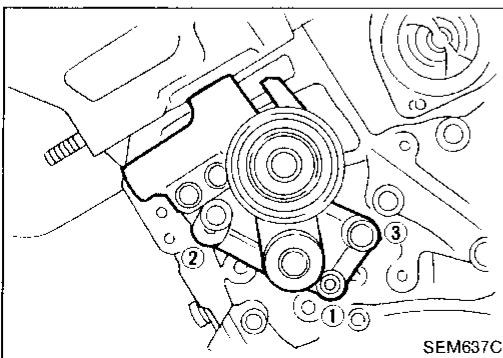

6. Install auto-tensioner and tighten nut (①) and bolts (②, ③) slightly by hand.

TIMING BELT

Installation (Cont'd)

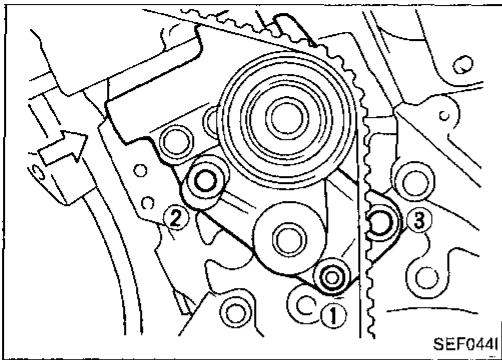

7. Push auto-tensioner slightly towards timing belt to prevent belt from slipping.

Set tensioner slightly by pushing timing belt. Then, turn crankshaft 10 degrees clockwise and tighten nut (①) and bolts (②, ③) to 16 to 21 N·m (1.6 to 2.1 kg·m, 12 to 15 ft·lb).

At this time, do not push auto-tensioner hard or belt will be adjusted too tightly.

GI

WA

EM

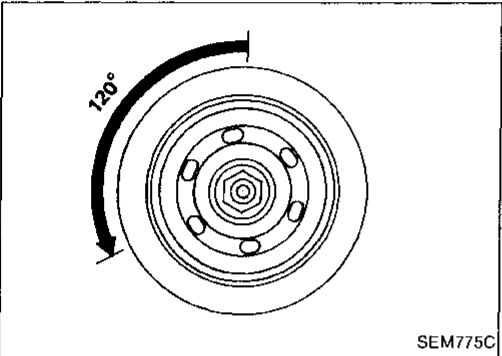

8. Turn crankshaft 120 degrees counterclockwise.
9. Loosen nut (①) and bolts (②, ③) 1/2 turn to set tensioner body as for back as it will go.
10. Turn crankshaft clockwise and set No. 1 cylinder at TDC on its compression stroke.

LC

EC

FE

AT

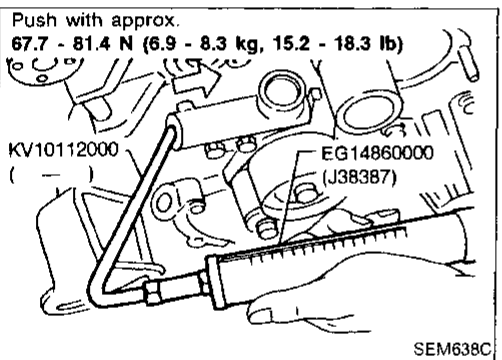

11. Push the end of pusher with approx. 58.8 N (6.0 kg, 13.2 lb) force using Tool (push-pull gauge) and tighten nut (①) and bolts (②, ③) to 16 to 21 N·m (1.6 to 2.1 kg·m, 12 to 15 ft·lb).

If deflection of timing belt exceeds specification in procedure 15., change applied pushing force.

PD

FA

RA

BR

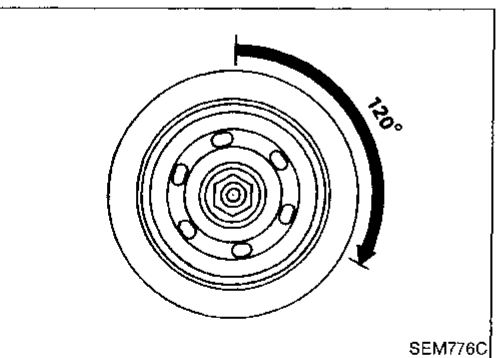

12. Turn crankshaft 120 degrees clockwise.
13. Turn crankshaft 120 degrees counterclockwise and set No. 1 cylinder at TDC on its compression stroke.

ST

RS

BT

HA

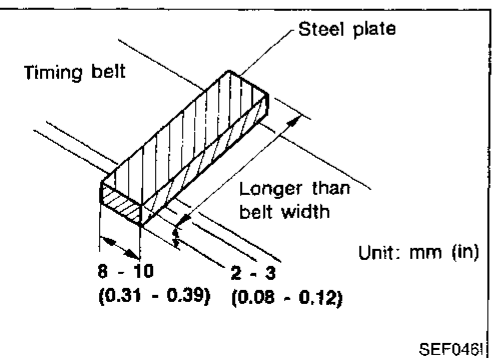

14. Prepare a suitable steel plate to measure belt deflection as shown.

EL

IDX

TIMING BELT

Installation (Cont'd)

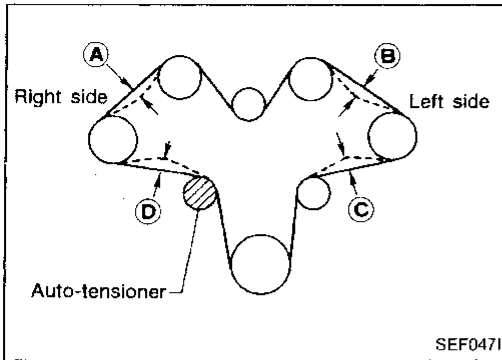

15.

- (1) Set plate and push it with 49 N (5 kg, 11 lb) force using Tool (push-pull gauge) at each position of timing belt mid-way between pulleys as shown.
- (2) Measure each deflection.

Deflection:

6 - 7 mm (0.24 - 0.28 in) or the average of each portion

$$\frac{\text{A} + \text{B} + \text{C} + \text{D}}{4}$$

is 6 - 7 mm (0.24 - 0.28 in)

If not within specification, repeat procedure from step 7 through step 15.

16. Confirm auto tensioner fixing nuts and bolts are tightened to 16 to 21 N·m (1.6 to 2.1 kg-m, 12 to 15 ft-lb).

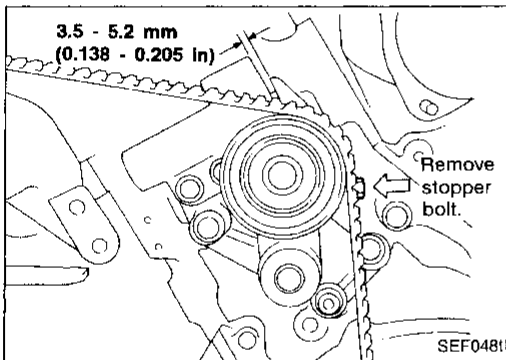

17.

- Remove the auto-tensioner stopper bolt.
- After 5 minutes check the projection of the rod (clearance between tensioner arm and pusher) stays at 3.5 to 5.2 mm (0.138 to 0.205 in).

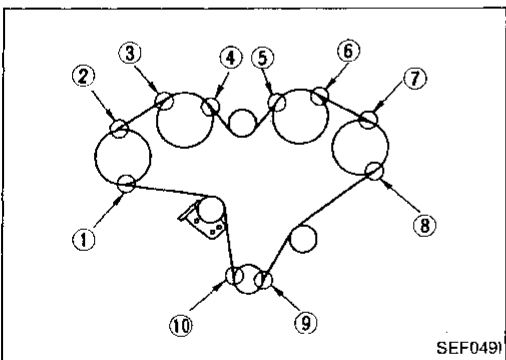

18. Check the proper installation (no slip or misplacement) of timing belt at each position as shown.

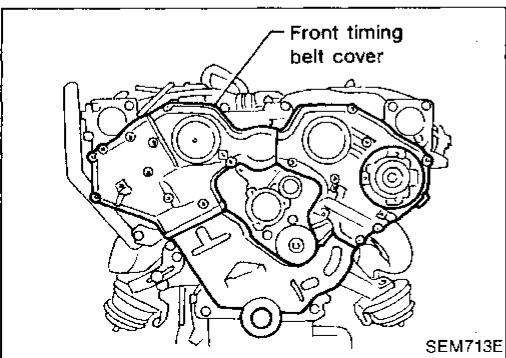

19. Install front timing belt covers.

20. Install water inlet and outlet.

Refer to LC section ("Thermostat").

OIL SEAL REPLACEMENT

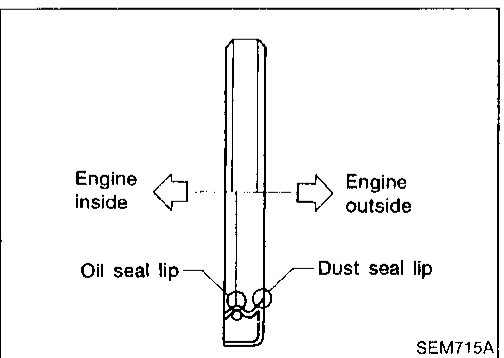
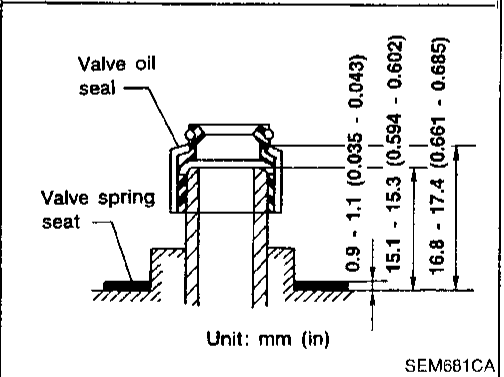
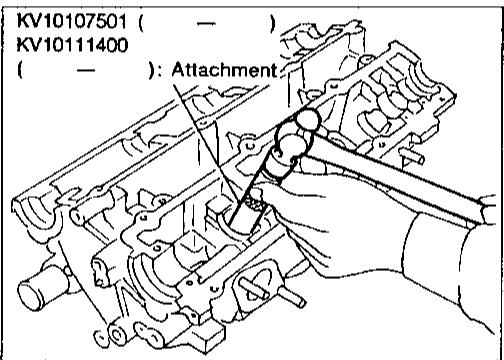
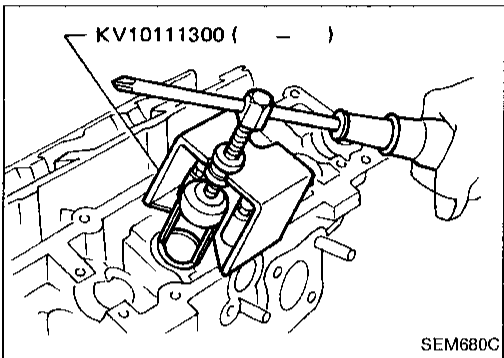
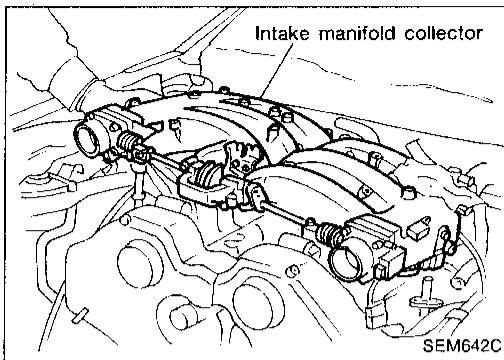

VALVE OIL SEAL

1. Remove intake manifold collector and valve cover.
2. Remove timing belt, camshaft sprocket and rear belt cover.
3. Remove camshaft brackets, camshaft and valve lifter.
4. Remove valve spring using Tool or a suitable tool.
 - Piston concerned should be set at TDC to prevent valve from falling.
5. Pry out valve oil seal.
6. Apply engine oil to new valve oil seal and install it.
 - Before installing valve oil seal, install inner valve spring seat.

GI

MA

EM

LC

EC

FE

AT

PD

FA

RA

BR

ST

RS

BT

HA

EL

DX

OIL SEAL INSTALLATION DIRECTION

- Install new oil seal in the direction shown in the figure.

OIL SEAL REPLACEMENT

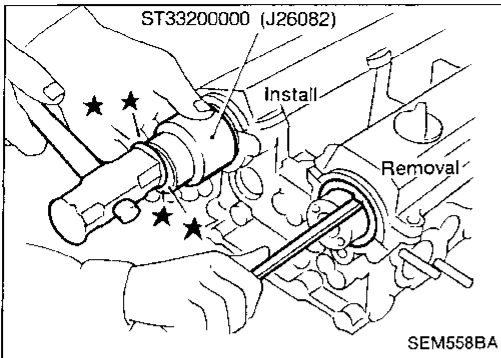

CAMSHAFT OIL SEAL

1. Remove timing belt and camshaft sprocket.
2. Remove rear belt cover and camshaft oil seal.

Be careful not to scratch camshaft.

3. Apply engine oil to new camshaft oil seal and install it using Tool or a suitable tool.

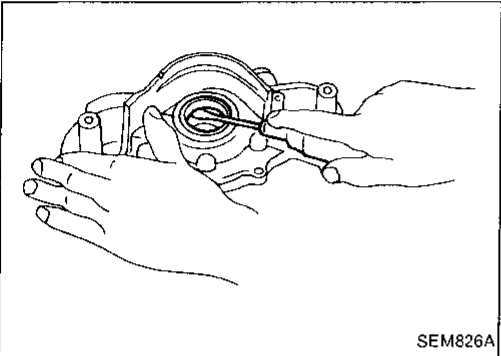

FRONT OIL SEAL

1. Remove timing belt and crankshaft sprocket.
2. Remove oil pan and oil pump assembly.
3. Remove front oil seal from oil pump body.

Be careful not to scratch oil pump body.

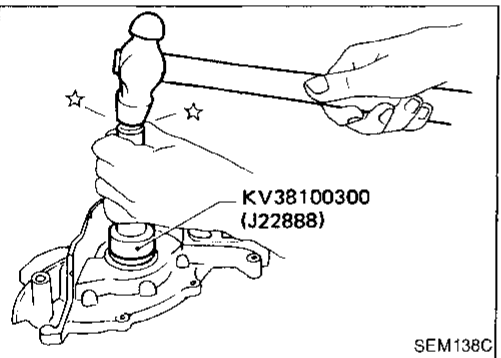

4. Apply engine oil to new oil seal and install it using Tool or a suitable tool.

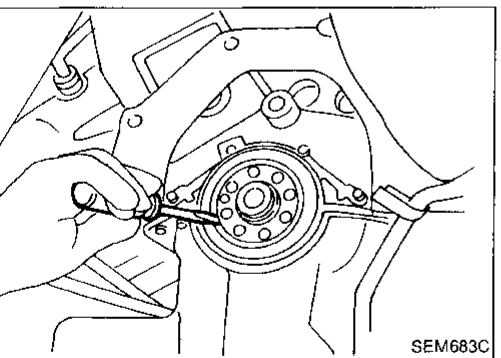

REAR OIL SEAL

1. Remove flywheel or drive plate.
2. Remove rear oil seal from retainer.

Be careful not to scratch crankshaft.

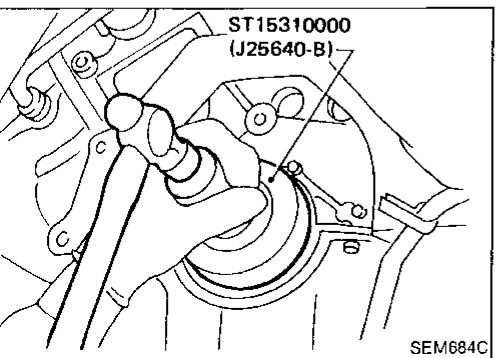

3. Apply engine oil to new oil seal and install it using Tool or a suitable tool.

THROTTLE BODIES

Precaution

A letter, "U" or "L", is stamped on the throttle bodies. When changing a throttle body, replace it with a new one that has the same mark.

Installation

The intention of this installation and adjustment procedure is to assure accurate synchronization of the throttle body opening points.

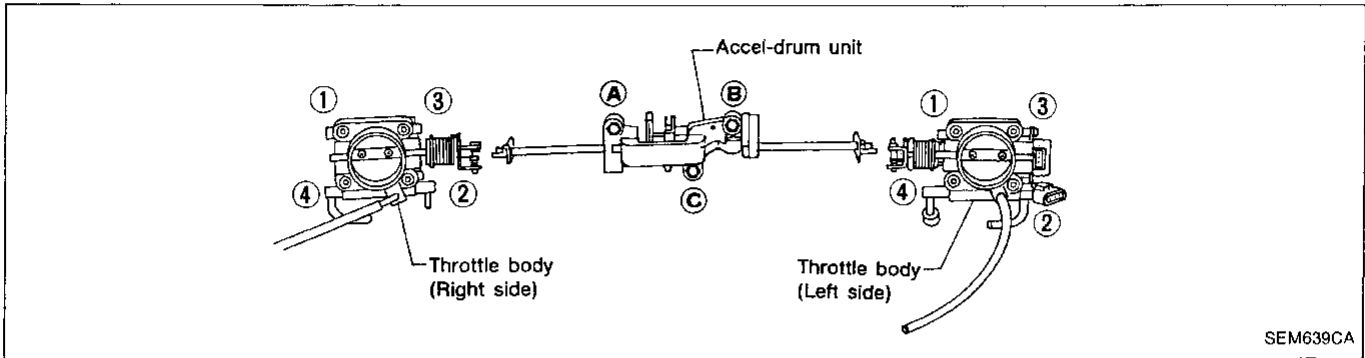

1. Install accel-drum unit and throttle bodies (right side and left side).

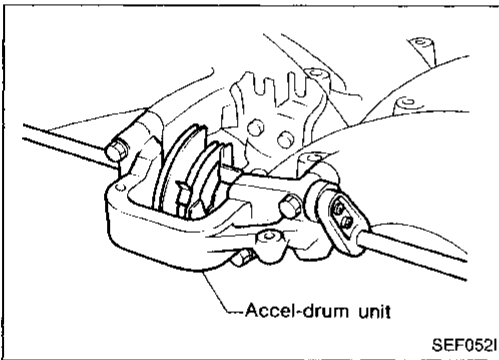

- When tightening bolts, free accel-drum unit so that drum unit is left under its own weight. Do not apply external force to accel-drum unit.
- When replacing throttle bodies only, you need not perform procedures (3), (4) and (5).

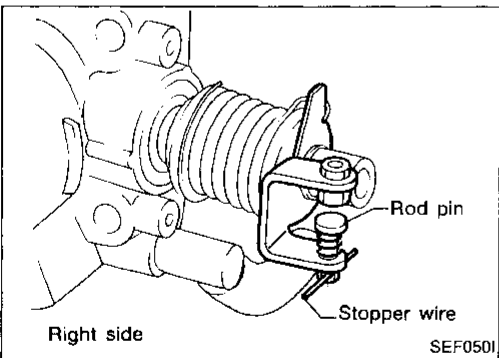

- Before installing each throttle body, confirm that stopper wire is installed in hole of rod pin. If not, install suitable wire.

Tightening order:

- (1) ① → ② → ③ → ④ :
9 - 11 N·m (0.9 - 1.1 kg-m, 78 - 95 in-lb)
- (2) ① → ② → ③ → ④ :
18 - 22 N·m (1.8 - 2.2 kg-m, 13 - 16 ft-lb)
- (3) ① → ② → ③ : Tighten by hand
- (4) ① → ② → ③ :
5 N·m (0.5 kg-m, 43 in-lb)
- (5) ① → ② → ③ :
20 N·m (2.0 kg-m, 14 ft-lb)

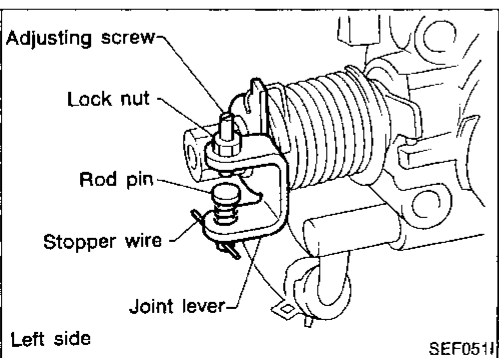

THROTTLE BODIES

Installation (Cont'd)

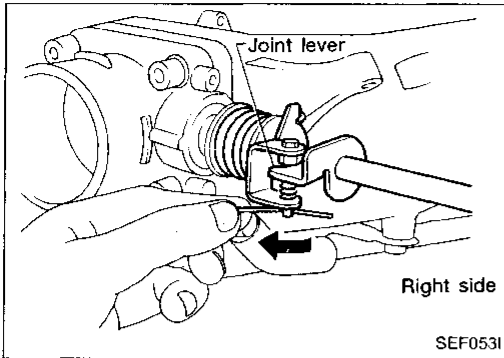

2. Pull out stopper wire of right side throttle body in order to secure right side joint lever.

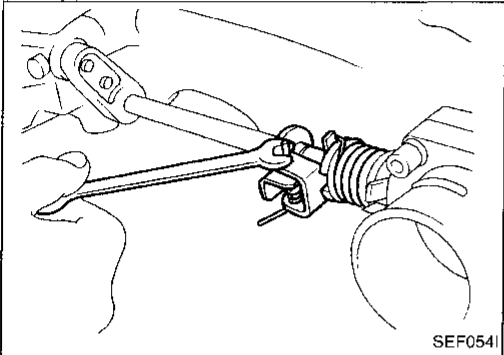

3. Loosen left side throttle body lock nut and back-out adjusting screw until there is clearance between the screw and joint lever.

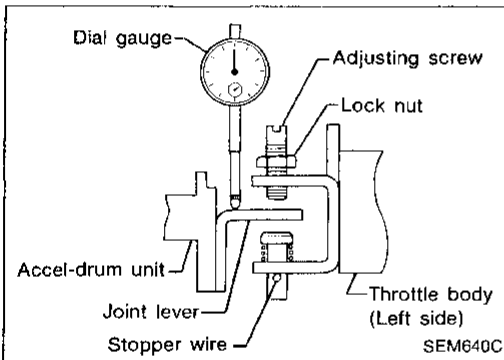

4. Set dial gauge on joint lever and set indicator to zero. Confirm that bottom end of adjusting screw is not in contact with joint lever of accelerator drum unit.

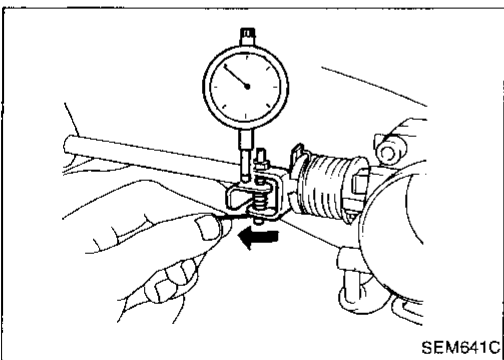

5. Pull out left side throttle body stopper wire from rod pin.

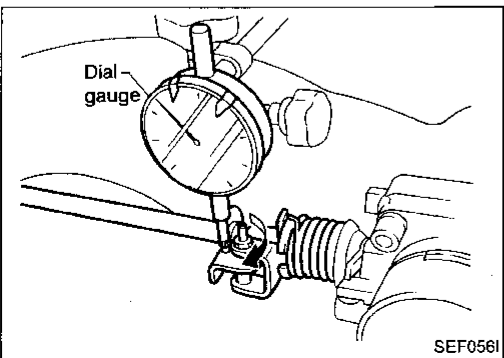

6. Turn adjusting screw until dial gauge indicator is within the following range.

Range: 0.07 - 0.13 mm (0.0028 - 0.0051 in)

Then tighten lock nut.

7. Confirm that the dial gauge indicator is still within the above range.

CYLINDER HEAD

SEC. 111•130•140

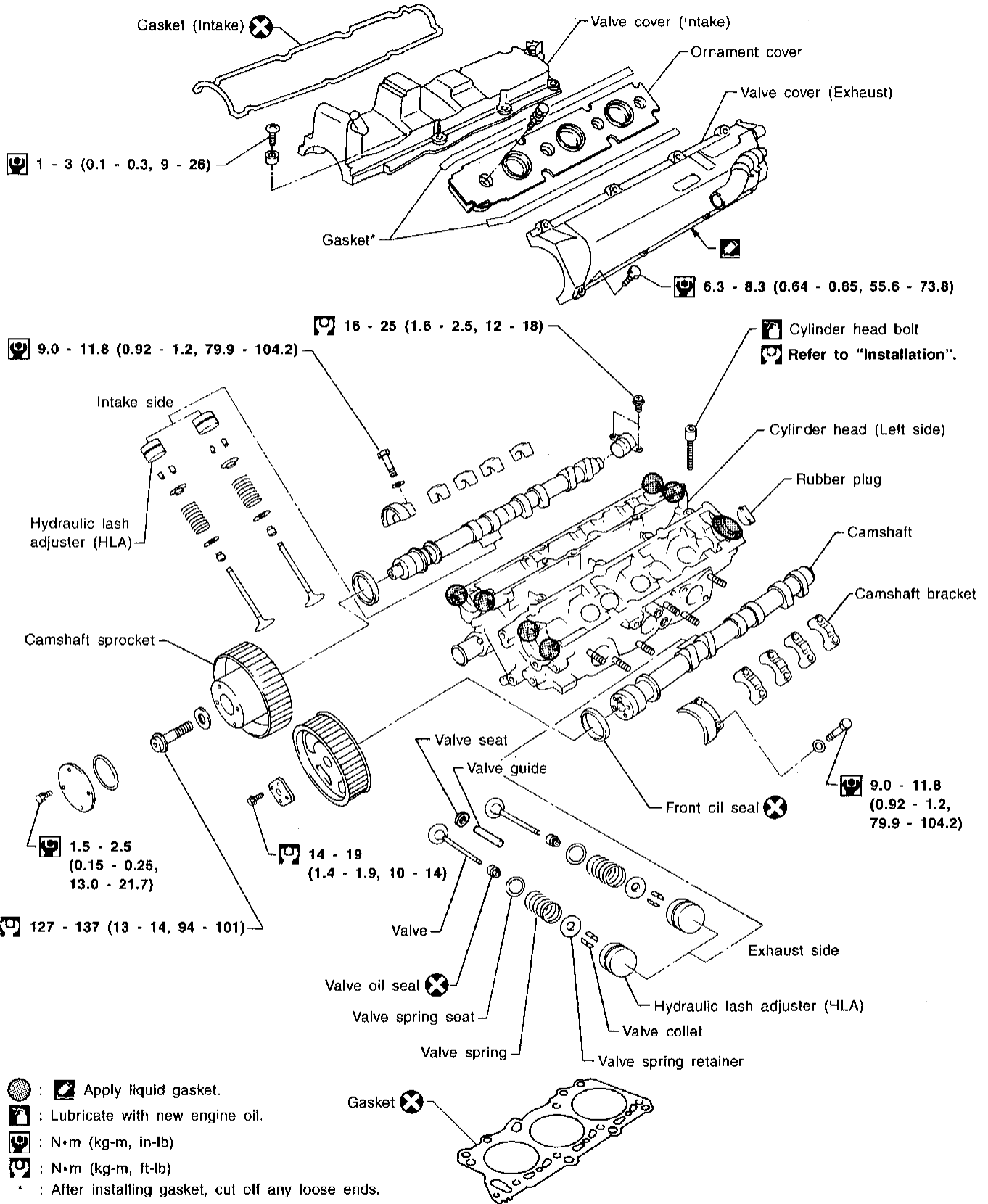

GI
MA
EM
LC
EC
FE
AT
PD
FA
RA
BR
ST
RS
BT
HA
EL
IDX

CYLINDER HEAD

CAUTION:

- When installing camshafts, camshaft bracket and oil seals, lubricate contacting surfaces with new engine oil.
- Apply new engine oil to bolt threads and seat surfaces when installing cylinder head, intake camshaft sprocket, and camshaft brackets.

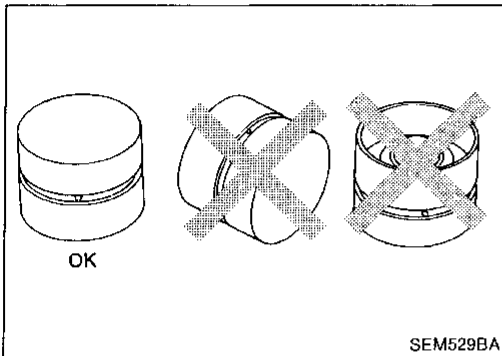

- Do not put hydraulic lash adjusters (HLA) upside down, otherwise air will enter HLA, causing it to make a noise.
- Do not disassemble HLA.
- Attach tags to HLAs so as not to mix them up.
- HLAs should be immersed in engine oil.

Removal

1. Remove intake manifold collector.

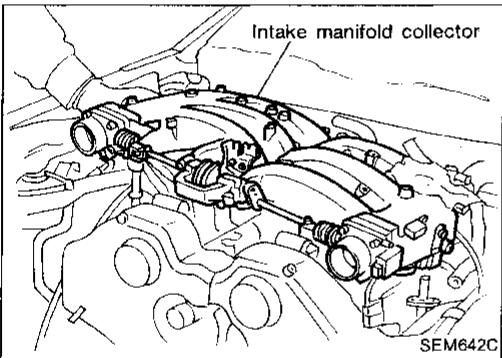

2. Remove injector pipe assembly.

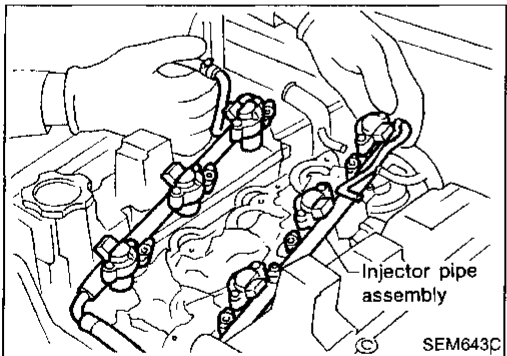

3. Remove valve covers.

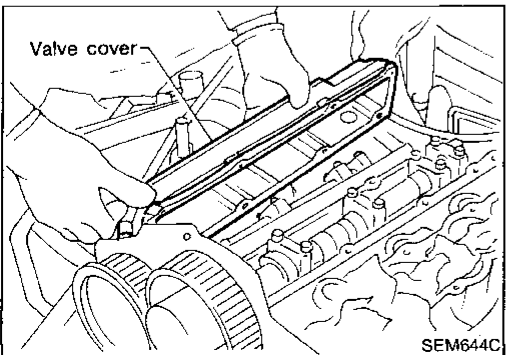

CYLINDER HEAD

Removal (Cont'd)

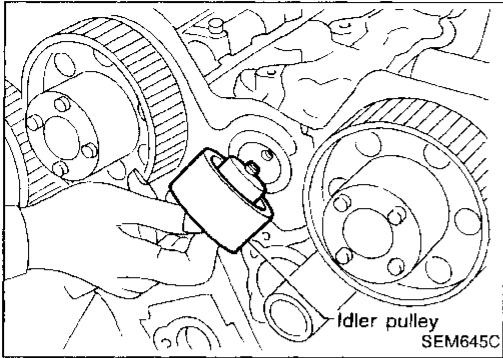

4. Remove timing belt.

Refer to "Removal" of TIMING BELT (EM-14).

5. Remove idler pulley and its stud bolt.

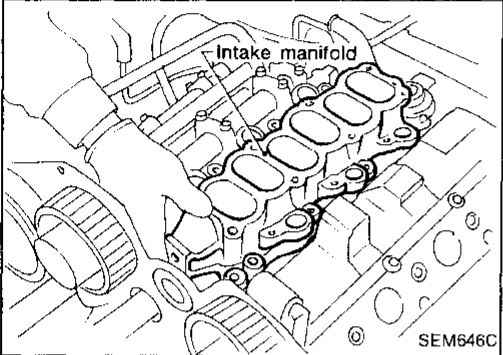

6. Remove intake manifold.

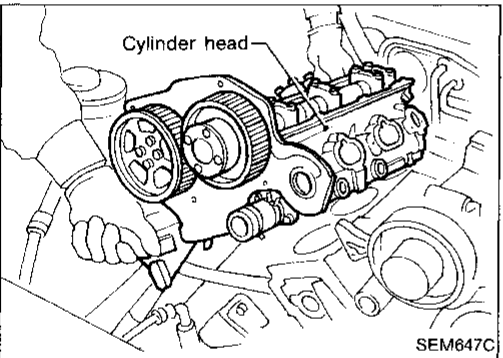

7. Disconnect front exhaust tube from exhaust manifold.

8. Remove cylinder head with exhaust manifold.

Cylinder head bolts should be loosened in two or three steps.

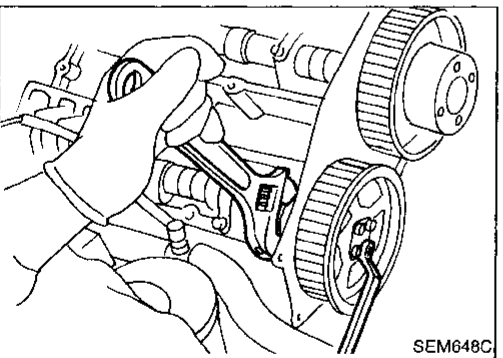

Disassembly

1. Remove exhaust manifold from cylinder head.

2. Remove camshaft sprockets.

3. Remove timing belt rear cover.

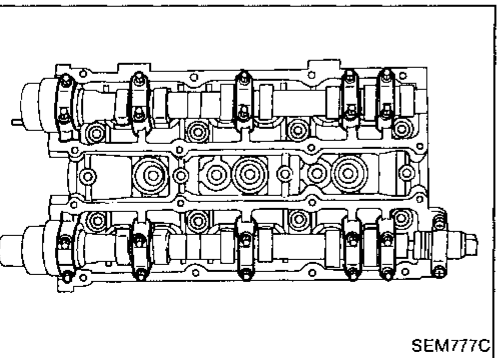

4. Remove camshaft brackets.

Bolts should be loosened in two or three steps.

Before removing camshaft, measure camshaft end play.

5. Remove oil seals, camshafts and HLAs.

GI

MA

EM

LC

EC

FE

AT

PD

FA

RA

BR

ST

RS

BT

HA

EL

IDX

CYLINDER HEAD

Disassembly (Cont'd)

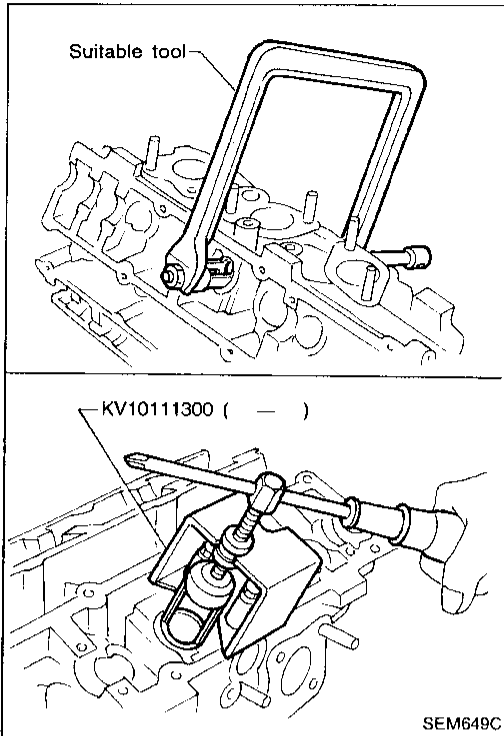

6. Remove valve springs with Tool or a suitable tool.
7. Pull out valve oil seals.

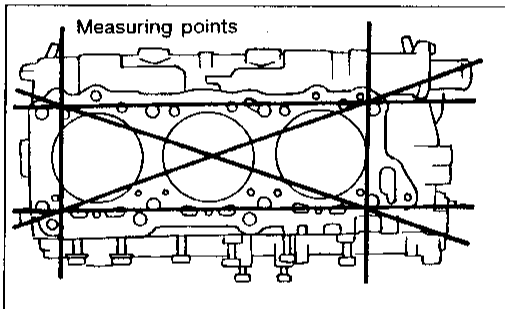

Inspection

CYLINDER HEAD DISTORTION

Clean surface of cylinder head.

Use a reliable straightedge and feeler gauge to check the flatness of cylinder head surface.

Head surface flatness:

Limit 0.1 mm (0.004 in)

If beyond the specified limit, replace it or resurface it.

Resurfacing limit:

The limit for cylinder head resurfacing is determined by the amount of cylinder block resurfacing.

Amount of cylinder head resurfacing is "A".

Amount of cylinder block resurfacing is "B".

The maximum limit:

$A + B = 0.2 \text{ mm (0.008 in)}$

After resurfacing cylinder head, check that camshaft rotates freely by hand. If resistance is felt, cylinder head must be replaced.

Nominal cylinder head height from camshaft center:

Refer to SDS (EM-53).

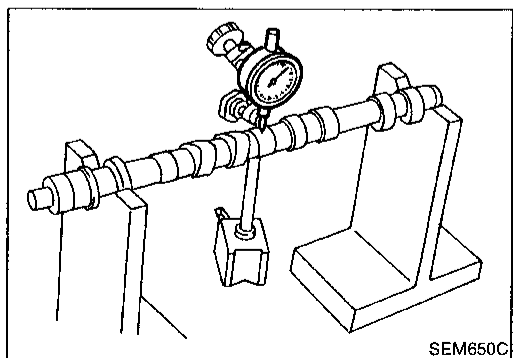
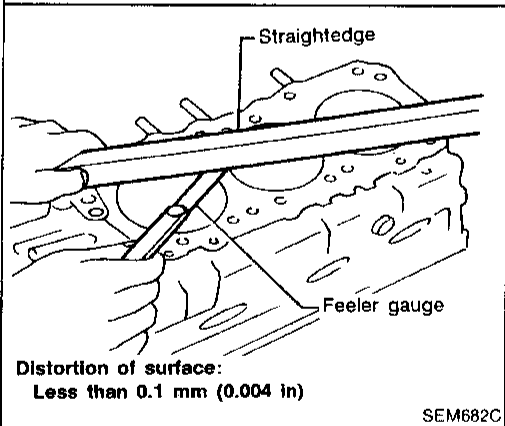

CAMSHAFT VISUAL CHECK

Check camshaft for scratches, seizure and wear.

CAMSHAFT RUNOUT

1. Measure camshaft runout at the center journal.

Runout (Total indicator reading):

Limit 0.1 mm (0.004 in)

2. If it exceeds the limit, replace camshaft.

CYLINDER HEAD

Inspection (Cont'd)

CAMSHAFT CAM HEIGHT

1. Measure camshaft cam height.
Standard cam height:
Intake 39.605 - 39.795 (1.5592 - 1.5667)
Exhaust 40.405 - 40.595 mm (1.5907 - 1.5982 in)
Cam wear limit:
0.15 mm (0.0059 in)
2. If wear is beyond the limit, replace camshaft.

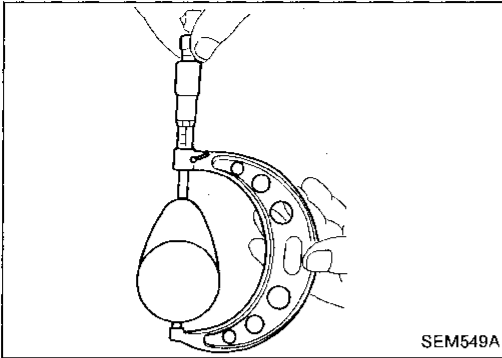

CAMSHAFT JOURNAL CLEARANCE

1. Install camshaft bracket and tighten bolts to the specified torque.
2. Measure inner diameter of camshaft bearing.
Standard inner diameter:
28.000 - 28.021 mm (1.1024 - 1.1032 in)
3. Measure outer diameter of camshaft journal.
Standard outer diameter:
27.935 - 27.955 mm (1.0998 - 1.1006 in)
4. If clearance exceeds the limit, replace camshaft and/or cylinder head.
Camshaft journal clearance limit:
0.15 mm (0.0059 in)

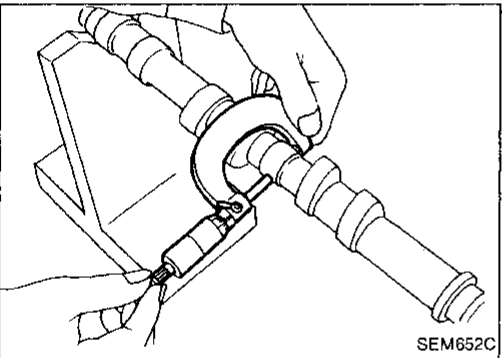
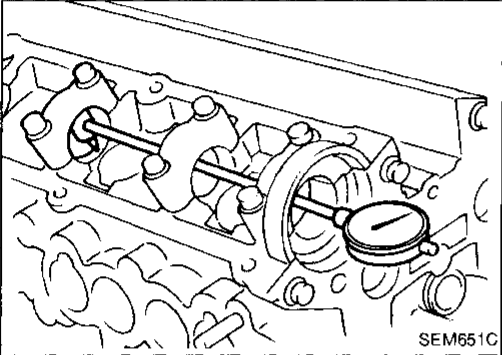

CAMSHAFT END PLAY

1. Install camshaft in cylinder head.
2. Measure camshaft end play.
Camshaft end play:
Standard
0.03 - 0.08 mm (0.0012 - 0.0031 in)

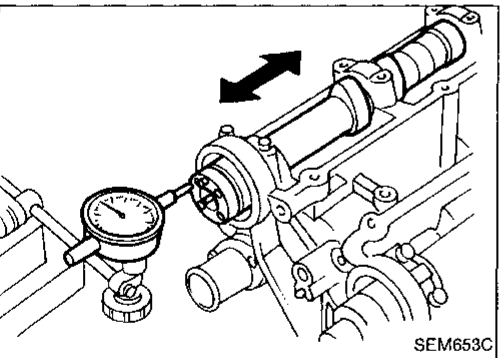

VALVE GUIDE CLEARANCE

1. Push valve stem out so that its end is even with valve guide height. Measure valve runout by moving valve.
Valve deflection limit (Dial gauge reading):
0.20 mm (0.0079 in)

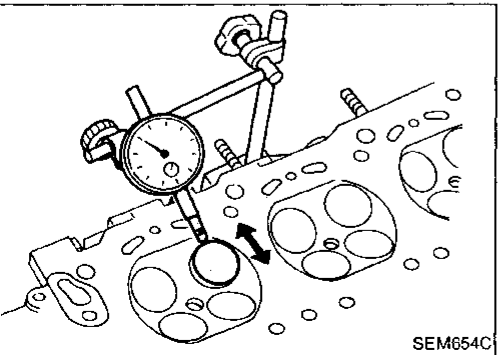

GI

MA

EM

LC

EC

FE

AT

PD

FA

RA

BR

ST

RS

BT

HA

EL

IDX

CYLINDER HEAD

Inspection (Cont'd)

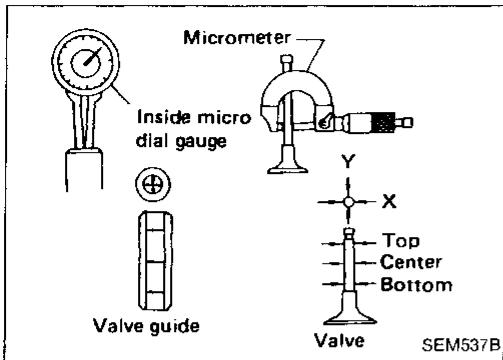

2. If it exceeds the limit, check valve to valve guide clearance.
 - a. Measure valve stem diameter and valve guide inner diameter.
 - b. Check that clearance is within specification.
**Valve stem to valve guide clearance limit:
0.10 mm (0.0039 in)**
 - c. If it exceeds the limit, replace valve or valve guide.

VALVE GUIDE REPLACEMENT

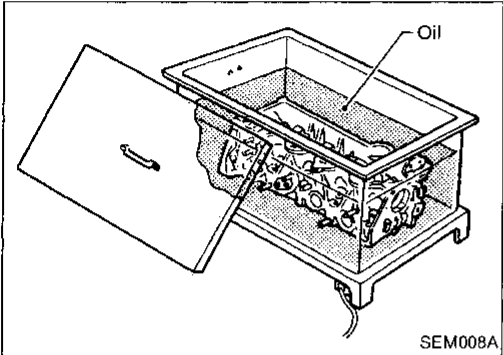

1. To remove valve guide, heat cylinder head to 150 to 160°C (302 to 320°F).

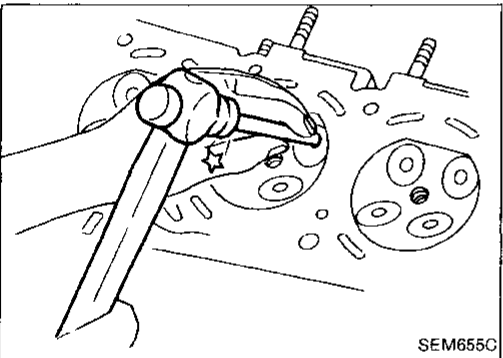

2. Drive out valve guide with a press [under a 20 kN (2 ton, 2.2 US ton, 2.0 Imp ton) pressure] or hammer and suitable tool.

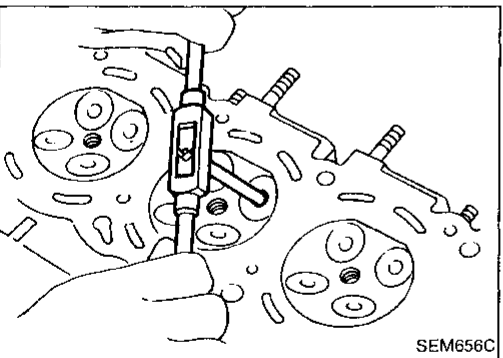

3. Ream cylinder head valve guide hole.
**Valve guide hole diameter
(for service parts):
Intake and Exhaust
10.175 - 10.196 mm (0.4006 - 0.4014 in)**

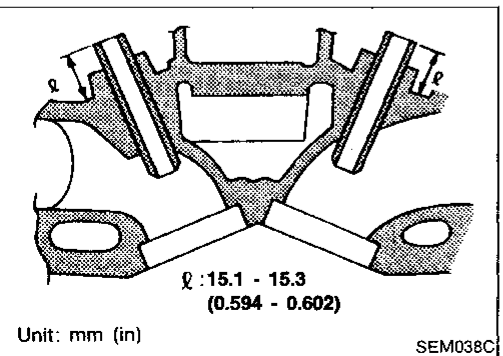

4. Heat cylinder head to 150 to 160°C (302 to 320°F) and press service valve guide onto cylinder head.
**Projection "ℓ":
15.1 - 15.3 mm (0.594 - 0.602 in)**

CYLINDER HEAD

Inspection (Cont'd)

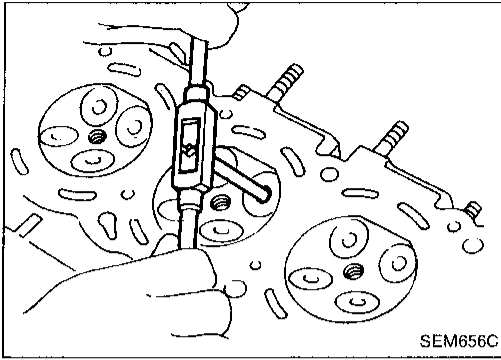

5. Ream valve guide.

Finished size:

Intake and Exhaust

6.000 - 6.018 mm (0.2362 - 0.2369 in)

VALVE SEATS

Check valve seats for evidence of pitting at valve contact surface, and reseat or replace if it is worn excessively.

- **Before repairing valve seats, check valve and valve guide for wear. If they have worn, replace them. Then correct valve seat.**
- **Cut with both hands to assure a uniform surface.**

REPLACING VALVE SEAT FOR SERVICE PARTS

1. Bore out old seat until it collapses. Boring should not continue beyond the bottom face of the seat recess in cylinder head.
2. Ream cylinder head recess.

Reaming bore for service valve seat

Oversize [0.5 mm (0.020 in)]:

Intake 36.500 - 36.516 mm (1.4370 - 1.4376 in)

Exhaust 32.000 - 32.016 mm (1.2598 - 1.2605 in)

Be sure to ream in circles concentric to the valve guide center. This will enable valve seat to fit correctly.

3. Heat cylinder head to 150 to 160°C (302 to 320°F).
4. Press fit valve seat until it seats on the bottom.

5. Cut or grind valve seat using suitable tool at the specified dimensions as shown in SDS (EM-54).
6. After cutting, lap valve seat with abrasive compound.
7. Check valve seat contact condition.

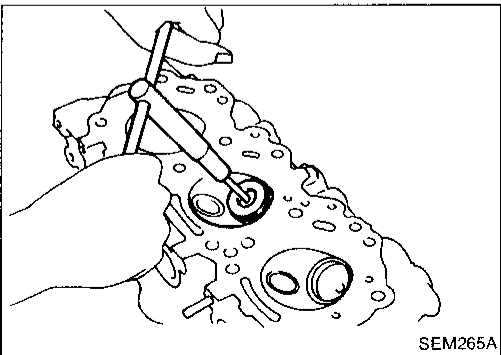
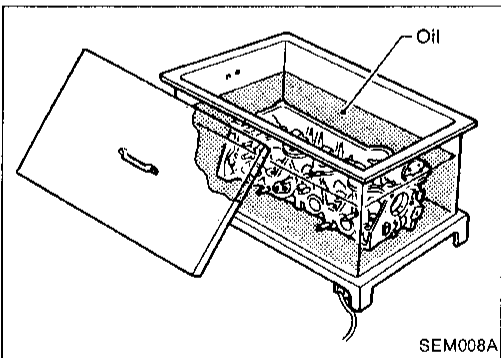
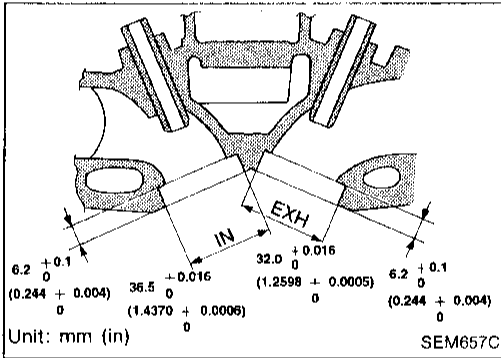

CYLINDER HEAD

Inspection (Cont'd)

VALVE DIMENSIONS

Check dimensions of each valve. For dimensions, refer to SDS (EM-53). When valve head has been worn down to 0.5 mm (0.020 in) in margin thickness, replace valve.

Grinding allowance for valve stem tip is 0.2 mm (0.008 in) or less.

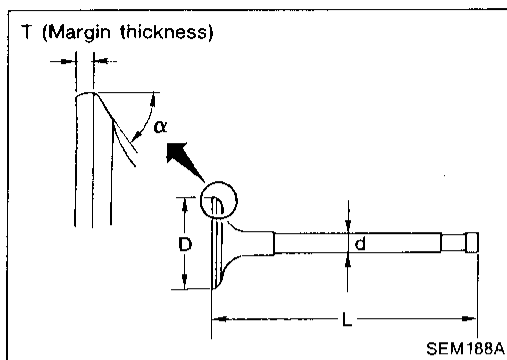

VALVE SPRING

Squareness

1. Measure dimension "S".

Out-of-square:

Less than 1.8 mm (0.071 in)

2. If it exceeds the limit, replace spring.

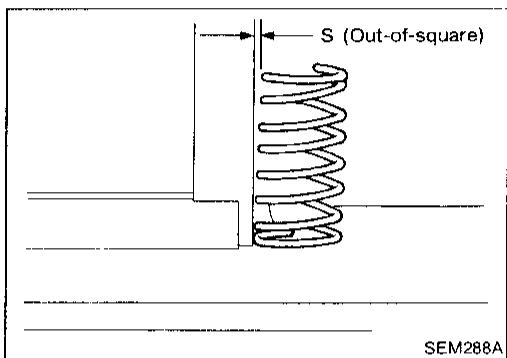

Pressure

Check valve spring pressure.

Pressure: N (kg, lb) at height mm (in)

Standard

536.4 (54.7, 120.6) at 26.5 (1.043)

Limit

452.79 (46.17, 101.80) at 26.5 (1.043)

If it exceeds the limit, replace spring.

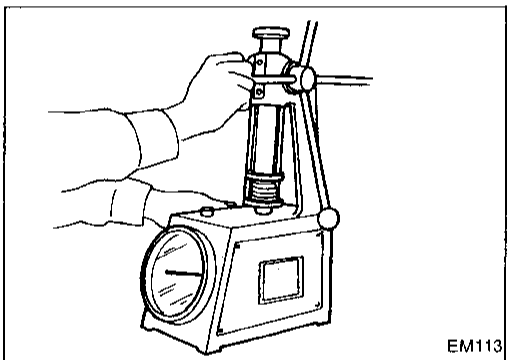

HYDRAULIC LASH ADJUSTER (HLA)

1. Check contact and sliding surfaces for wear or scratches.

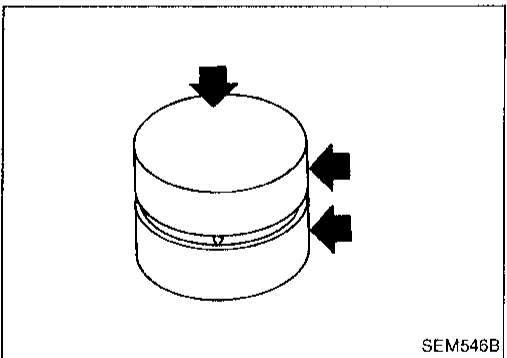

2. Check diameter of HLA.

Outer diameter:

30.955 - 30.965 mm (1.2187 - 1.2191 in)

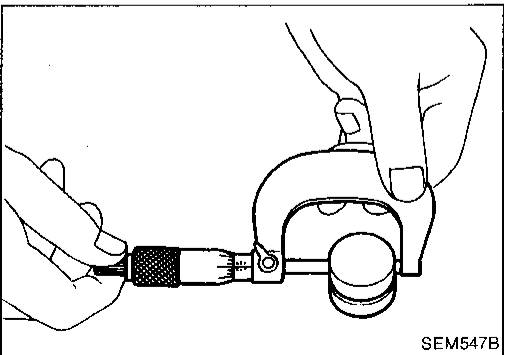

CYLINDER HEAD

Inspection (Cont'd)

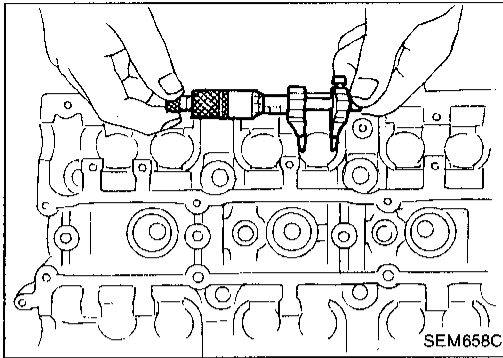

3. Check HLA guide inner diameter.

Inner diameter:

31.000 - 31.020 mm (1.2205 - 1.2213 in)

Standard clearance between HLA and HLA guide:

0.035 - 0.065 mm (0.0014 - 0.0026 in)

GI

MA

EM

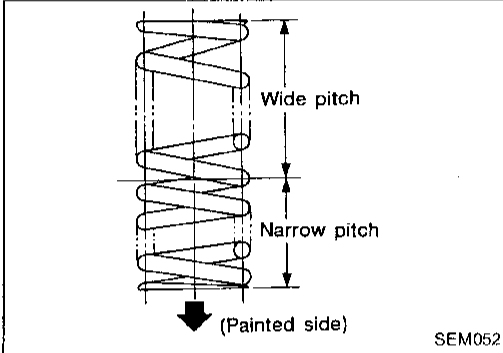

Assembly

1. Install valve component parts.

- Always use new valve oil seal. Refer to OIL SEAL REPLACEMENT (EM-21).
- Install valve spring (uneven pitch type) with its narrow pitch side (painted side) toward cylinder head side.

LC

EC

FE

AT

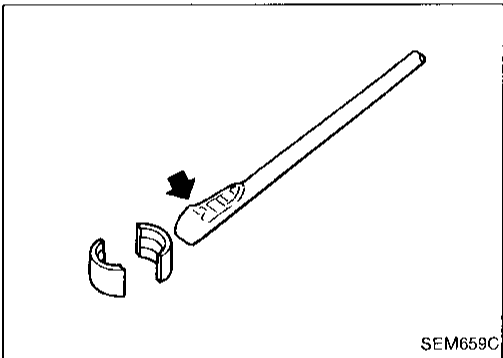

- To facilitate installation of collet, apply a small amount of grease to a piece of wire or a pencil and attach collet to wire or pencil, as shown.

PD

FA

RA

BR

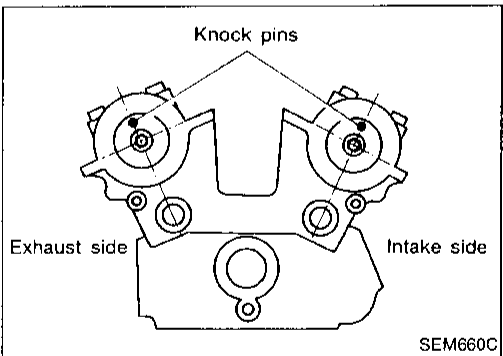

2. Install camshafts as shown.

- Apply new engine oil to contacting surfaces of camshafts before installing them.

ST

RS

BT

HA

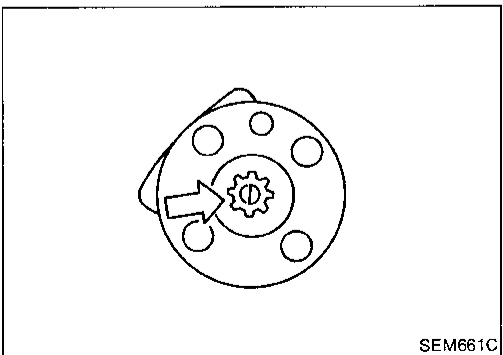

- Exhaust camshaft (left side) has spline for camshaft position sensor.

EL

IDX

CYLINDER HEAD

Assembly (Cont'd)

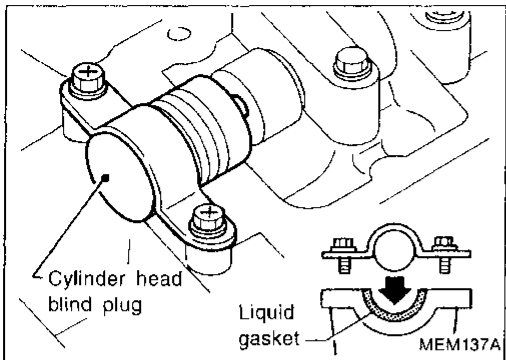

- When installing cylinder head blind plug, apply liquid gasket to solenoid valve surfaces.

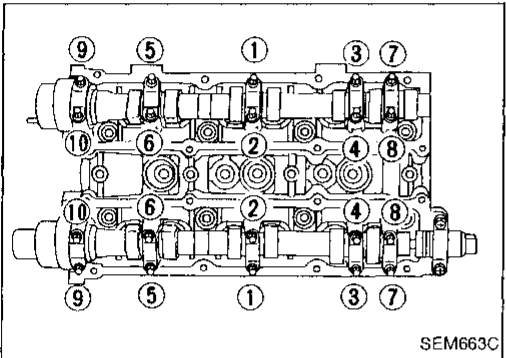

3. Install camshaft brackets.

Tighten camshaft bracket bolts gradually in two or three stages.

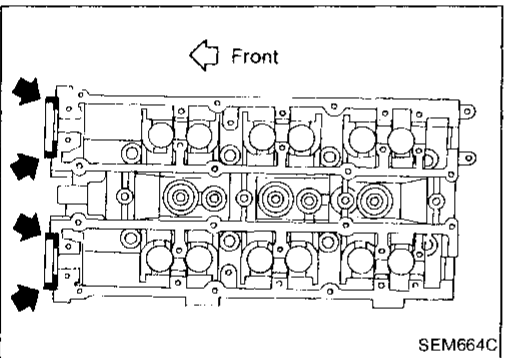

When installing front side camshaft brackets, apply liquid gasket as shown.

4. Apply engine oil to camshaft oil seal lip and install it in place.

Always use new camshaft oil seal.

5. Install rear timing belt cover.
6. Install camshaft sprockets.

When tightening bolts, fix camshaft to prevent it from rotating.

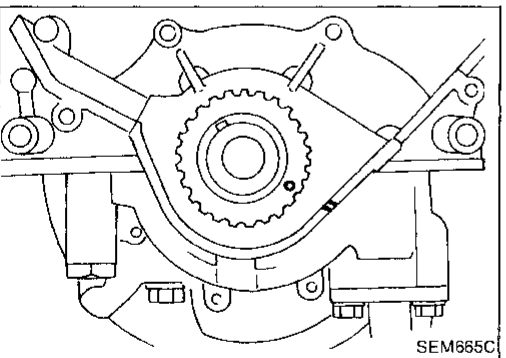

Installation

1. Set No. 1 piston at TDC on its compression stroke as follows:

(1) Align crankshaft sprocket aligning mark with mark on oil pump body.

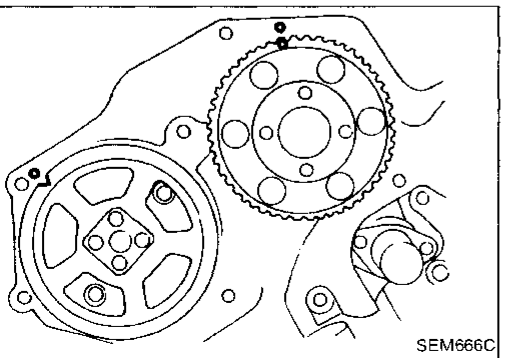

(2) Align camshaft sprocket aligning mark with mark on timing belt rear cover.

CYLINDER HEAD

Installation (Cont'd)

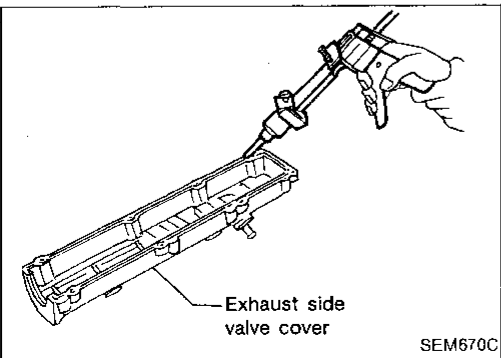
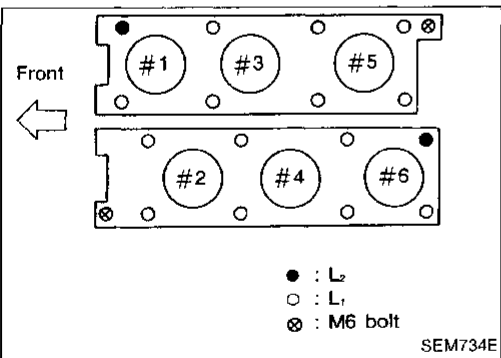
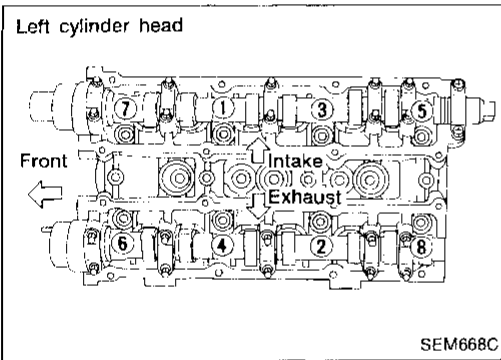
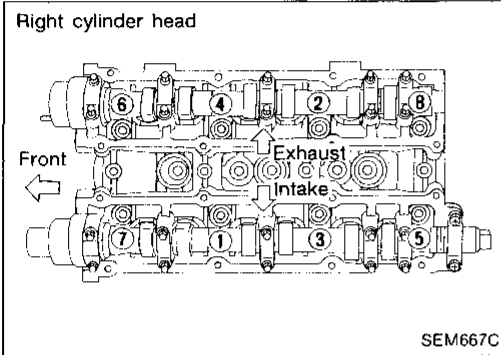
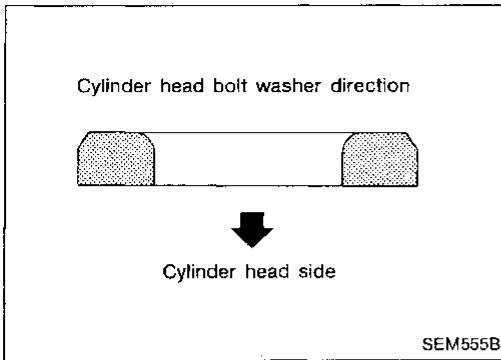

2. Install cylinder head with new gasket.
 - Be sure to install washers between bolts and cylinder head.
 - Do not rotate crankshaft and camshaft separately, or valves will hit piston heads.
3. Install cylinder head bolts.
 - Install short bolts (L₂) into the correct holes of cylinders #1 and #6 as shown in figure of step (6).
 - Lubricate threads and seat surfaces of the bolts with new engine oil.

4. Tighten cylinder head bolts in numerical order.
 - Tightening procedure
 - (1) Tighten all bolts to 39 N·m (4.0 kg-m, 29 ft-lb).
 - (2) Tighten all bolts to 123 N·m (12.5 kg-m, 90 ft-lb).
 - (3) Loosen all bolts completely.
 - (4) Tighten all bolts to 34 to 44 N·m (3.5 to 4.5 kg-m, 25 to 33 ft-lb).
 - (5) Tighten all bolts to 123 N·m (12.5 kg-m, 90 ft-lb) or if an angle wrench is available, tighten bolts 70 to 75 degrees (L₁), 65 to 70 degrees (L₂) clockwise.

- (6) Tighten bolts (⊗) as shown to 10 to 12 N·m (1.0 to 1.2 kg-m, 87 to 104 in-lb).

5. Install valve covers.

When installing exhaust side valve covers, apply liquid gasket as shown.

GI

WA

EM

LC

EC

FE

AT

PD

FA

RA

BR

ST

RS

BT

HA

EL

IDX

CYLINDER HEAD

Installation (Cont'd)

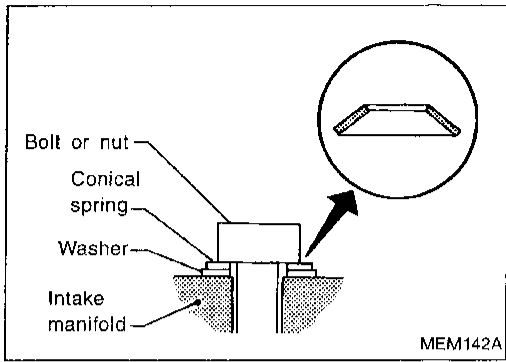

6. Install intake manifold.

Pay attention to direction of conical spring.

7. Install remaining parts.

ENGINE REMOVAL

SEC. 112-111

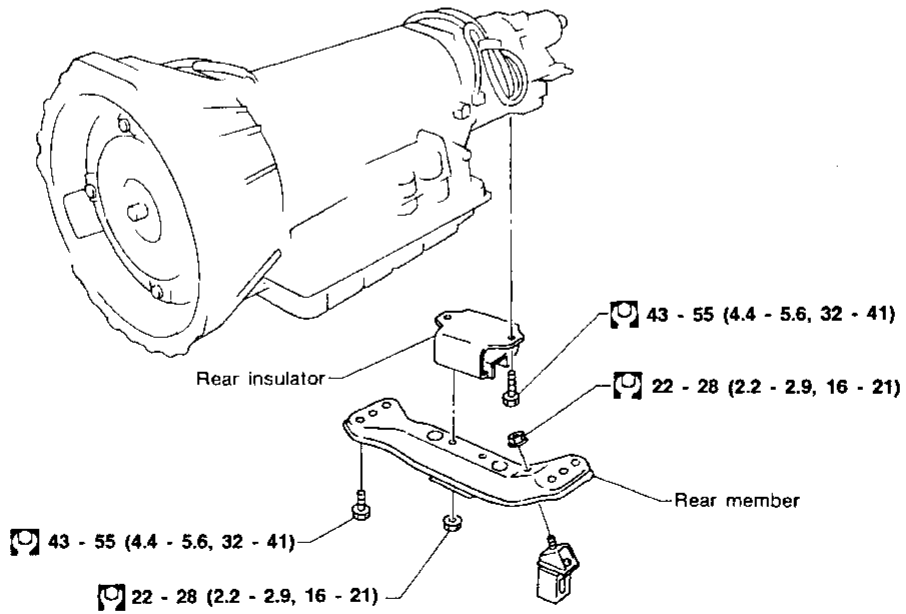
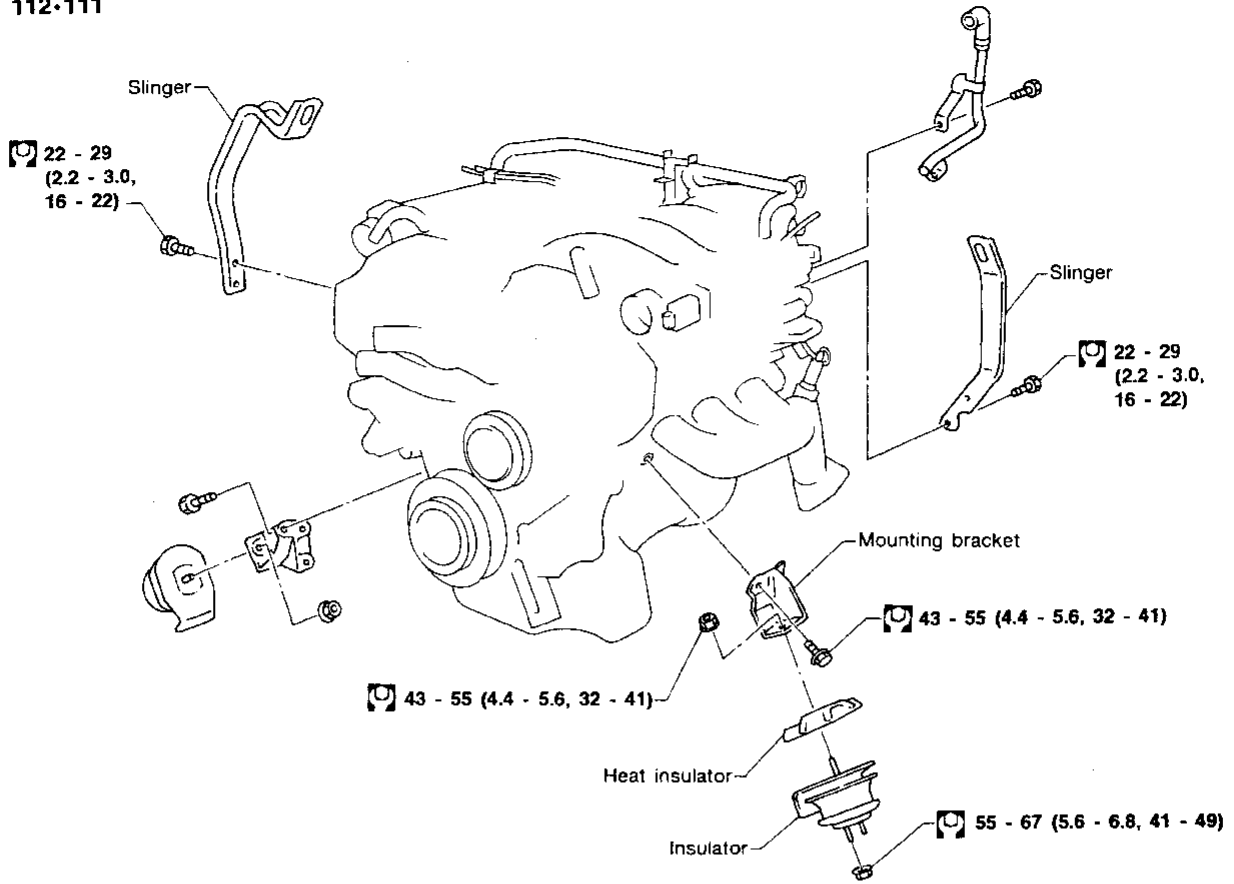

: N·m (kg-m, ft-lb)

GI

MA

EM

LC

EC

FE

AT

PD

FA

RA

BR

ST

RS

BT

HA

EL

IDX

ENGINE REMOVAL

WARNING:

- Situate vehicle on a flat and solid surface.
- Place chocks at front and back of rear wheels.
- Do not remove engine until exhaust system has completely cooled off. Otherwise, you may burn yourself and/or fire may break out in fuel line.
- For safety during subsequent steps, the tension of wires should be slackened against the engine.
- Before disconnecting fuel hose, release fuel pressure from fuel line.
Refer to EC section ("Fuel Pressure Release", "BASIC SERVICE PROCEDURE").
- Be sure to hoist engine and transmission in a safe manner.
- For engines not equipped with engine slingers, attach proper slingers and bolts described in PARTS CATALOG.

CAUTION:

- When lifting engine, be careful not to strike adjacent parts, especially the following: Accelerator wire casing, brake lines, and brake master cylinder.
- In hoisting the engine, always use engine slingers in a safe manner.
- Before separating engine and transmission, remove crankshaft position sensor (OBD) from the assembly.
- Always take extra care not to damage edge of crankshaft position sensor (OBD), or ring gear teeth.

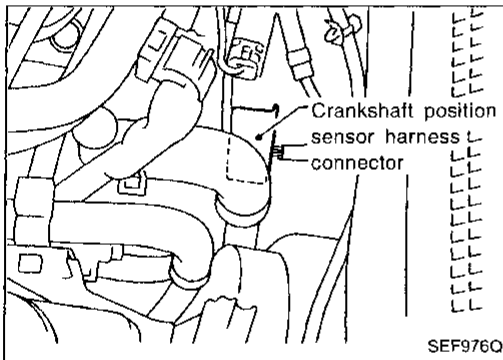

Removal

1. Remove engine under cover and hood.
2. Drain coolant from both cylinder block drain plugs, and radiator drain cock.
3. Drain engine oil from drain plug of oil pan.
4. Remove vacuum hoses, fuel tubes, wires, harnesses and connectors and so on.
5. Remove front exhaust tubes and propeller shaft.
6. Remove radiator.
7. Remove drive belts, cooling fan and coupling.
8. Remove P/S oil pump, alternator, A/C pump from engine, and starter motor.
9. Remove transmission from vehicle.
10. Hoist engine with engine slingers and remove engine mounting bolts from both sides.

Refer to AT section ("REMOVAL AND INSTALLATION").

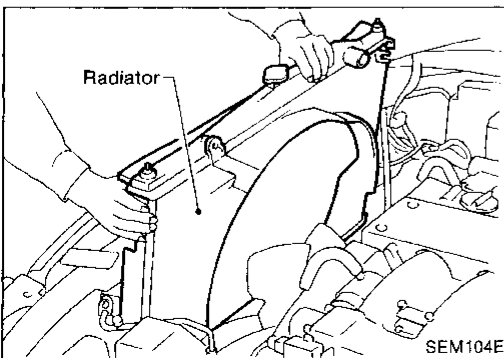

ENGINE REMOVAL

Removal (Cont'd)

11. Lift engine out of vehicle as shown

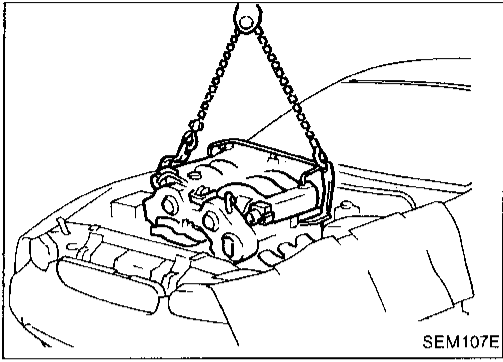

Installation

Installation is in the reverse order of removal.

GI

MA

EM

LC

EC

FE

AT

PD

FA

RA

BR

ST

RS

BT

HA

EL

IDX

CYLINDER BLOCK

SEC. 110-120-150

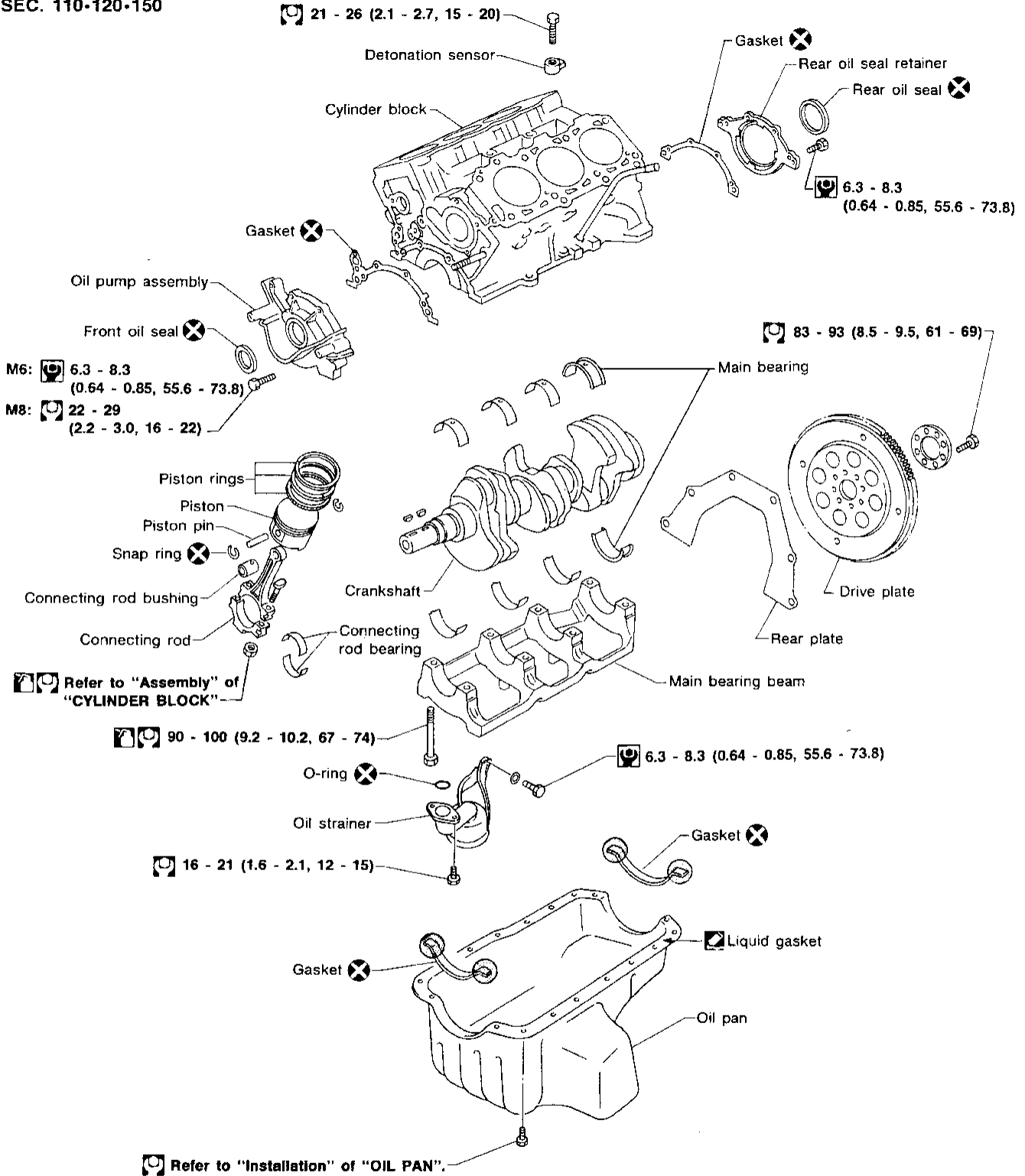

- : Apply liquid gasket.
- : Lubricate with new engine oil.
- : N·m (kg·m, in·lb)
- : N·m (kg·m, ft·lb)

CYLINDER BLOCK

CAUTION:

- When installing bearings, pistons, or other sliding parts, lubricate contacting surfaces with new engine oil.
- Place removed parts such as bearings and bearing caps in their proper order and direction.
- When installing connecting rod nuts, and main bearing cap bolts, apply new engine oil to threads and seating surfaces.
- Do not allow any magnetic materials to contact the signal plate teeth of drive plate.

CI

MA

EM

LC

EC

FE

AT

PD

FA

RA

BR

ST

RS

BT

HA

EL

IDX

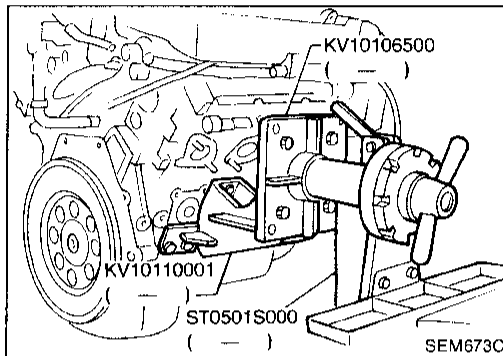

Disassembly

PISTON AND CRANKSHAFT

1. Place engine on a work stand.
2. Remove timing belt.
3. Drain coolant and remove water pump.
4. Drain oil.
5. Remove oil pan, oil pump and rear oil seal retainer.
6. Remove intake manifold collector, intake manifold and cylinder head.
7. Remove pistons.
 - When disassembling piston and connecting rod, remove snap ring first. Then heat piston to 60 to 70°C (140 to 158°F), or use piston pin press stand at room temperature.

CAUTION:

- When piston rings are not replaced, make sure that piston rings are mounted in their original positions.
- When replacing piston rings, if there is no punchmark, install with either side up.

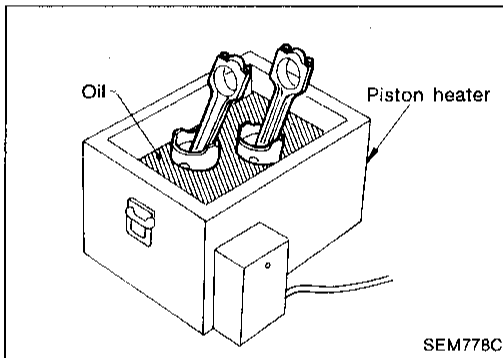

8. Remove bearing cap and crankshaft.

- Before removing bearing cap, measure crankshaft end play.
- Bolts should be loosened in two or three steps.

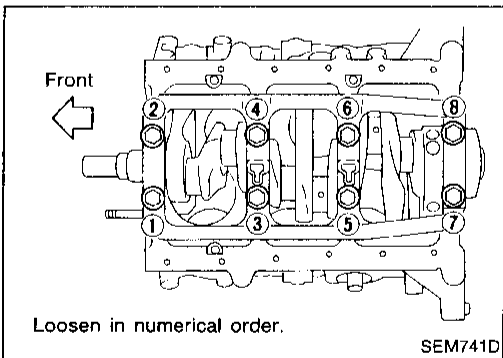

Inspection

PISTON AND PISTON PIN CLEARANCE

- Check that piston pin is pressed smoothly into pin hole by finger pressure at room temperature.
1. Measure inner diameter of piston pin hole "dp".
 - Standard diameter "dp":
21.987 - 21.999 mm (0.8656 - 0.8661 in)
 2. Measure outer diameter of piston pin "Dp".
 - Standard diameter "Dp":
21.989 - 22.001 mm (0.8657 - 0.8662 in)

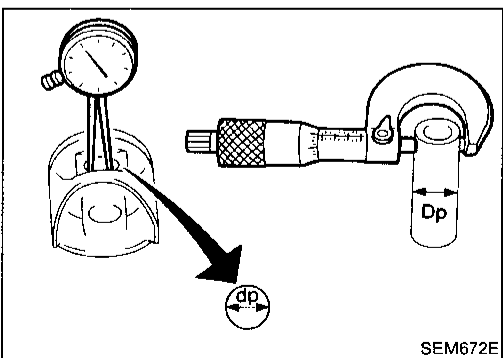

CYLINDER BLOCK

Inspection (Cont'd)

3. Calculate piston pin clearance.

$$dp - Dp = -0.004 \text{ to } 0 \text{ mm } (-0.0002 \text{ to } 0 \text{ in})$$

If it exceeds the above value, replace piston assembly with pin.

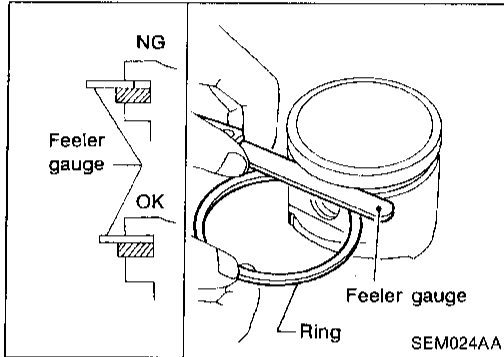

PISTON RING SIDE CLEARANCE

Side clearance:

Top ring

0.040 - 0.073 mm (0.0016 - 0.0029 in)

2nd ring

0.030 - 0.063 mm (0.0012 - 0.0025 in)

Max. limit of side clearance:

0.1 mm (0.004 in)

Oil ring:

0.015 - 0.185 mm (0.0006 - 0.0073 in)

Max. limit of side clearance:

0.2 mm (0.008 in)

If out of specification, replace piston and/or piston ring assembly.

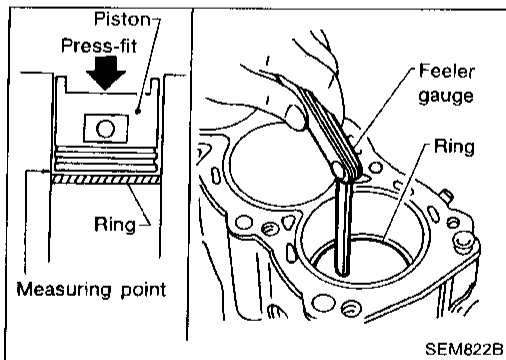

PISTON RING END GAP

End gap:

Top ring

0.21 - 0.40 mm (0.0083 - 0.0157 in)

2nd ring

0.50 - 0.76 mm (0.0197 - 0.0299 in)

Oil ring

0.20 - 0.76 mm (0.0079 - 0.0299 in)

Max. limit of end gap:

1.0 mm (0.039 in)

If out of specification, replace piston ring. If gap still exceeds the limit even with a new ring, rebore cylinder and use oversized piston and piston rings.

Refer to SDS (EM-55).

- When replacing the piston, check the cylinder block surface for scratches or seizure. If scratches or seizure is found, hone or replace the cylinder block.

CYLINDER BLOCK

Inspection (Cont'd)

CONNECTING ROD BEND AND TORSION

Bend:

Limit 0.15 mm (0.0059 in) per 100 mm (3.94 in) length

Torsion:

Limit 0.3 mm (0.012 in) per 100 mm (3.94 in) length

If it exceeds the limit, replace connecting rod assembly.

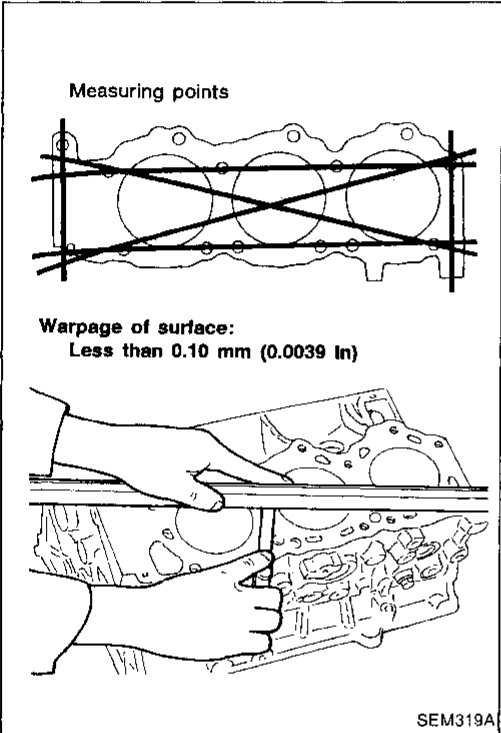
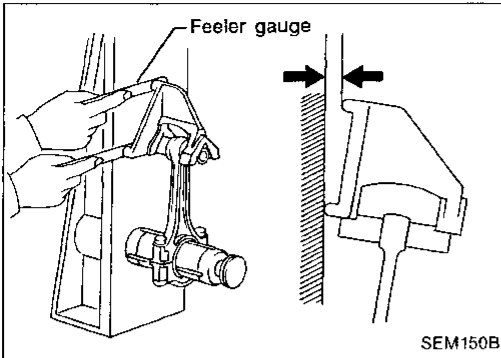

CYLINDER BLOCK DISTORTION AND WEAR

1. Clean upper face of cylinder block. Use a reliable straightedge and a feeler gauge to check the flatness of cylinder block surface.

Limit:

0.10 mm (0.0039 in)

2. If out of specification, resurface it. The limit for cylinder block resurfacing is determined by the amount of cylinder head resurfacing.

Amount of cylinder head resurfacing is "A".

Amount of cylinder block resurfacing is "B".

The maximum limit is as follows:

$$A + B = 0.2 \text{ mm (0.008 in)}$$

3. If necessary, replace cylinder block.

PISTON-TO-BORE CLEARANCE

1. Using a bore gauge, measure cylinder bore for wear, out-of-round and taper.

Standard inner diameter:

Refer to SDS (EM-56).

Wear limit:

0.20 mm (0.0079 in)

If it exceeds the limit, rebore all cylinders. Replace cylinder block if necessary.

Out-of-round (X - Y) Standard:

Less than 0.015 mm (0.0006 in)

Taper (A - B - C) Standard:

Less than 0.015 mm (0.0006 in)

2. Check for scratches and seizure. If seizure is found, hone it.

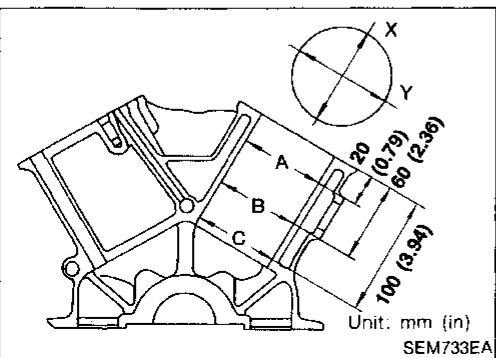
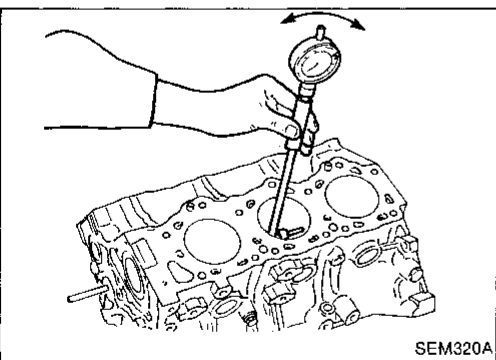

GI

MA

EM

LC

EC

FE

AT

PD

FA

RA

BR

ST

RS

BT

HA

EL

IDX

CYLINDER BLOCK

Inspection (Cont'd)

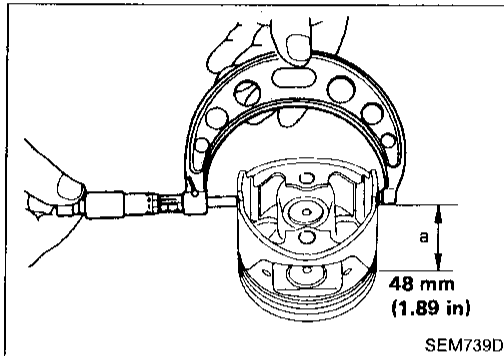
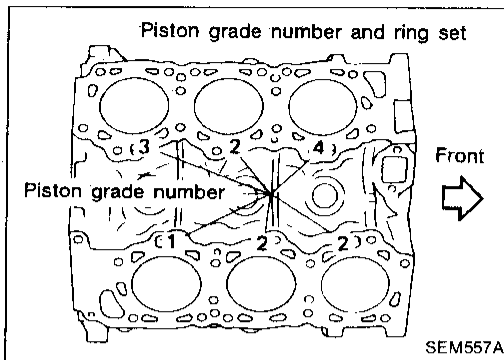

- If cylinder block or piston is replaced, match piston grade with grade number on cylinder block upper surface.

3. Measure piston skirt diameter.
Piston diameter "A":
Refer to SDS (EM-55).
Measuring point "a" (Distance from the top):
48.0 mm (1.89 in)
4. Check that piston-to-bore clearance is within specification.
Piston-to-bore clearance:
0.015 - 0.035 mm (0.0006 - 0.0014 in)
5. Determine piston oversize according to amount of cylinder wear.

Oversize pistons are available for service. Refer to SDS (EM-55).

6. Cylinder bore size is determined by adding piston-to-bore clearance to piston diameter "A".

Rebored size calculation:

$$D = A + B - C$$

where,

D: Bored diameter

A: Piston diameter as measured

B: Piston-to-bore clearance

C: Honing allowance 0.02 mm (0.0008 in)

7. Install main bearing caps and tighten bolts to the specified torque. This will prevent distortion of cylinder bores.
8. Bore out cylinders.
 - **When any cylinder needs boring, all other cylinders must also be bored.**
 - **Do not cut too much out of cylinder bore at a time. Do not cut more than 0.05 mm (0.0020 in) in diameter at a time.**
9. Hone cylinders to obtain specified piston-to-bore clearance.
10. Measure finished cylinder bore for out-of-round and taper.
 - **Measurement should be done after cylinder bore cools down.**

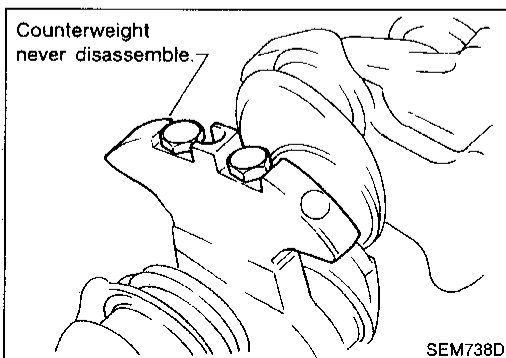

CRANKSHAFT

CAUTION:

Never attempt to disassemble crankshaft counterweight.

CYLINDER BLOCK

Inspection (Cont'd)

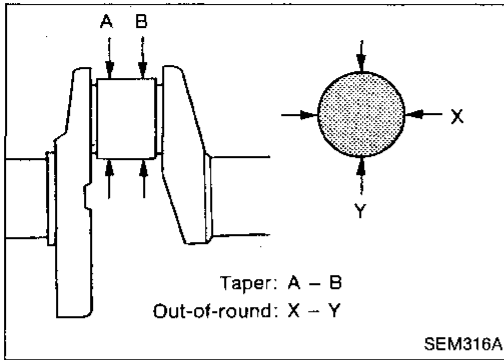

1. Check crankshaft main and pin journals for score, wear or cracks.
2. With a micrometer, measure journals for taper and out-of-round.

Out-of-round (X - Y):

Less than 0.005 mm (0.0002 in)

Limit:

0.02 mm (0.0008 in)

Taper (A - B):

Less than 0.005 mm (0.0002 in)

Limit:

0.02 mm (0.0008 in)

GI

MA

EM

LC

EC

FE

AT

PD

FA

RA

BR

ST

RS

BT

HA

EL

IDX

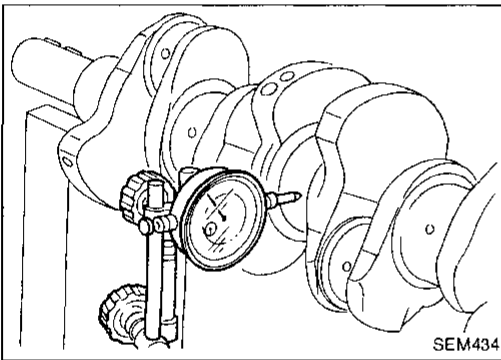

3. Measure crankshaft runout.

Runout (Total indicator reading):

Less than 0.10 mm (0.0039 in)

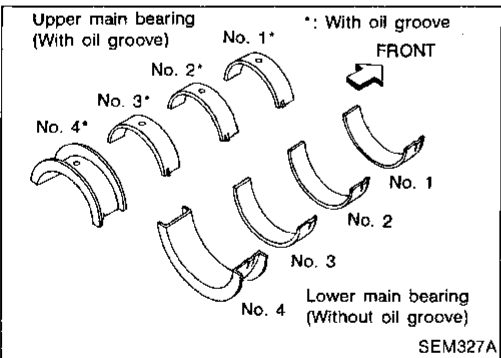

BEARING CLEARANCE

- Use either of the following two methods, however, method "A" gives more reliable results and is preferable.

Method A (Using bore gauge & micrometer)

Main bearing

1. Set main bearings in their proper positions on cylinder block and main bearing cap.

2. Install main bearing cap to cylinder block.

Tighten all bolts in correct order in two or three stages.

3. Measure inner diameter "dm" of each main bearing.
"dm":

Refer to SDS (EM-56).

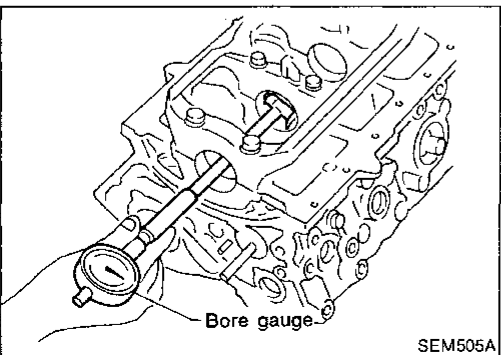

CYLINDER BLOCK

Inspection (Cont'd)

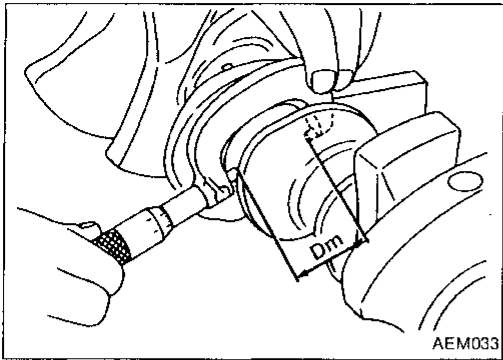

4. Measure outer diameter "Dm" of each crankshaft main journal.
 "Dm":
 Refer to SDS (EM-57).
5. Calculate main bearing clearance.
Main bearing clearance (dm - Dm):
Standard
 0.028 - 0.055 mm (0.0011 - 0.0022 in)
Limit
 0.090 mm (0.0035 in)
6. If it exceeds the limit, replace bearing.
7. If clearance cannot be adjusted within the standard of any bearing, grind crankshaft journal and use undersized bearing (EM-58).

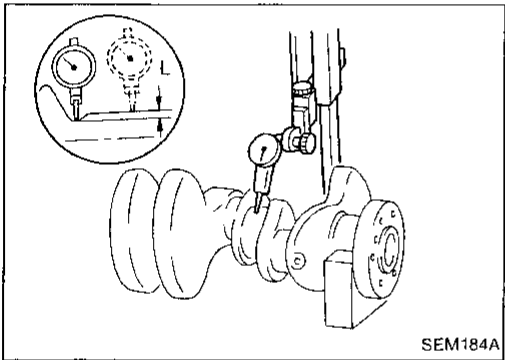

CAUTION:

- When grinding crankshaft journal, confirm that "L" dimension in fillet roll is more than the specified limit.
 "L": 0.1 mm (0.004 in)
- Refer to SDS for available service parts when grinding it.

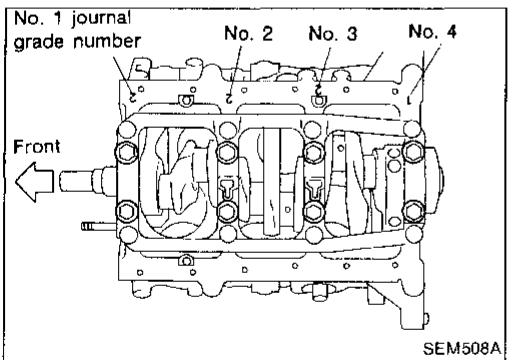

8. If crankshaft, cylinder block or main bearing is reused again, measure main bearing clearance.

If crankshaft, cylinder block and main bearings are replaced, select thickness of main bearings as follows:

- a. Grade number of each cylinder block main journal is punched on the respective cylinder block.
- b. Grade number of each crankshaft main journal is punched on the No. 1 counter weight of crankshaft.

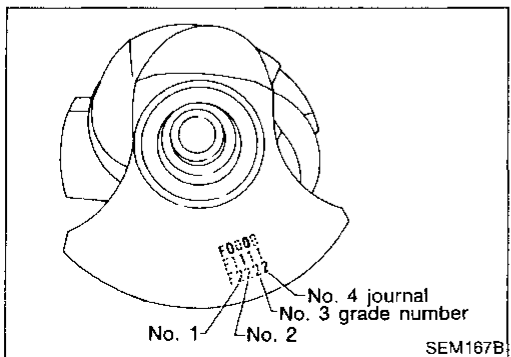

CYLINDER BLOCK

Inspection (Cont'd)

- c. Select main bearing with suitable thickness according to the following table.

Main bearing grade number:

		Cylinder block main journal grade number		
		0	1	2
Crankshaft journal grade number	0	0	1	2
	1	1	2	3
	2	2	3	4

For example:

Main journal grade number: 1

Crankshaft journal grade number: 2

Main bearing grade number = 1 + 2
= 3

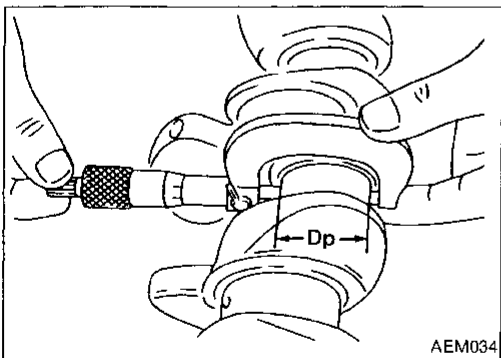
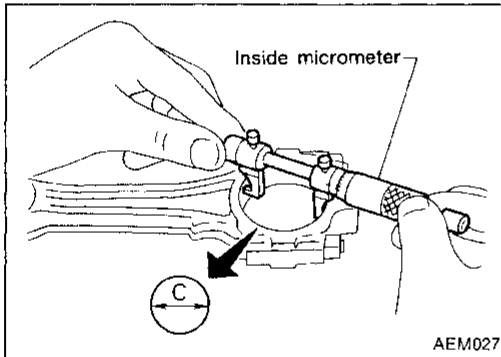

Connecting rod bearing (Big end)

1. Install connecting rod bearing to connecting rod and cap.
2. Install connecting rod cap to connecting rod.

Tighten bolts to the specified torque.

3. Measure inner diameter "C" of each bearing.

"C":

53.000 - 53.013 mm (2.0866 - 2.0871 in)

4. Measure outer diameter "Dp" of each crankshaft pin journal.

5. Calculate connecting rod bearing clearance.

Connecting rod bearing clearance (C - Dp):

Standard

0.028 - 0.048 mm (0.0011 - 0.0019 in)

Limit

0.090 mm (0.0035 in)

6. If it exceeds the limit, replace bearing.
7. If clearance cannot be adjusted within the standard of any bearing, grind crankshaft journal and use undersized bearing. Refer to step 7 of "BEARING CLEARANCE — Main bearing" (EM-45).

CYLINDER BLOCK

Inspection (Cont'd)

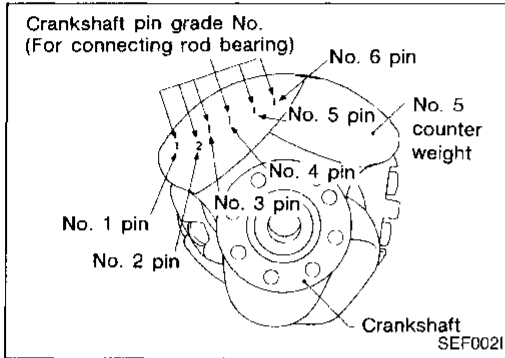
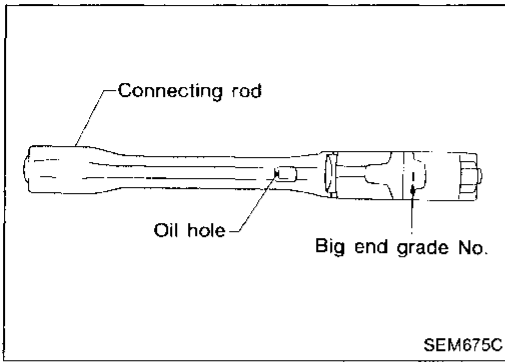

8. If crankshaft, connecting rods or bearings are replaced, select thickness of connecting rod bearings as follows:
- Grade number of each connecting rod big end is punched on the respective connecting rod.

- Grade number of each crankshaft pin journal is punched on the No. 5 counter weight of crankshaft.

- Select connecting rod bearing with suitable thickness according to the following table.

Connecting rod bearing grade number:

		Connecting rod big end grade number	
		0	1 (I)
Crankshaft pin grade number	0	0	1
	1 (I)	1	2
	2 (II)	2	3

For example:

Connecting rod big end grade number: 1

Crankshaft pin grade number: 2

Connecting rod bearing grade number = 1 + 2
= 3

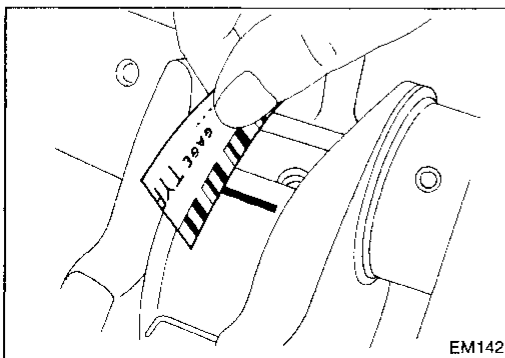

Method B (Using plastigage)

CAUTION:

- Do not turn crankshaft or connecting rod while plastigage is being inserted.
- When bearing clearance exceeds the specified limit, ensure that the proper bearing has been installed. If incorrect bearing clearance exists, use a thicker or undersized main bearing to ensure specified clearance.

CYLINDER BLOCK

Inspection (Cont'd)

CONNECTING ROD BUSHING CLEARANCE (Small end)

1. Measure inner diameter "C" of bushing.
2. Measure outer diameter "Dp" of piston pin.
3. Calculate connecting rod bushing clearance.

$$C - Dp = 0.005 - 0.017 \text{ mm (0.0002 - 0.0007 in)}$$

Limit: 0.023 mm (0.0009 in)

If it exceeds the limit, replace connecting rod assembly or connecting rod bushing and/or piston set with pin.

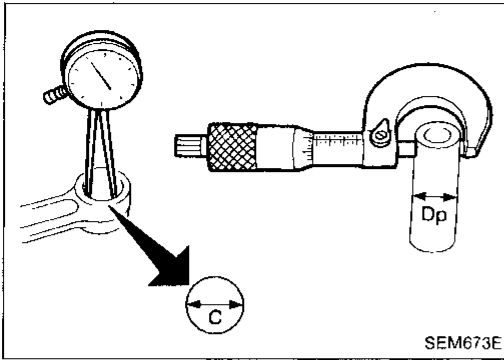

SEM673E

REPLACEMENT OF CONNECTING ROD BUSHING (Small end)

1. Drive in small end bushing until it is flush with end surface of rod.

Be sure to align the oil holes.

2. After driving in small end bushing, ream the bushing. This is to ensure the clearance between connecting rod bushing and piston pin is the specified value.

Clearance between connecting rod bushing and piston pin: 0.005 - 0.017 mm (0.0002 - 0.0007 in)

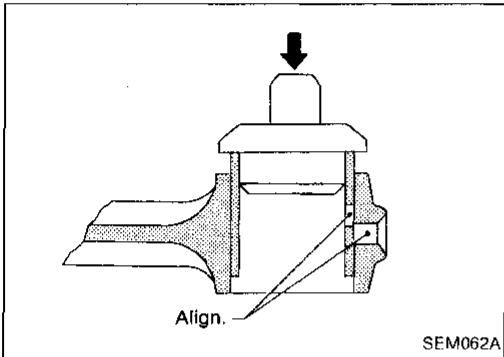

SEM062A

DRIVE PLATE RUNOUT

Runout (Total indicator reading):

Less than 0.15 mm (0.0059 in)

CAUTION:

- Be careful not to damage the signal plate, especially the teeth.
- Check the drive plate for deformation or cracks.
- Keep any magnetized objects away from the signal plate.
- Do not allow any magnetic materials to contact the signal plate teeth.

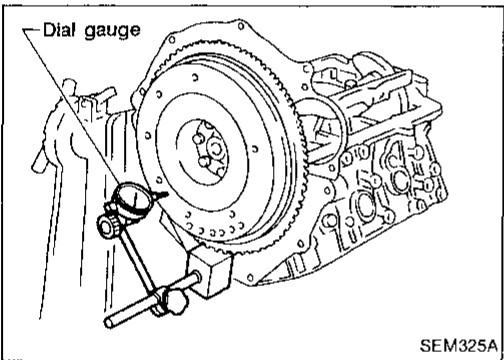

SEM325A

Assembly

PISTON

1. Install new snap ring on one side of piston pin hole.

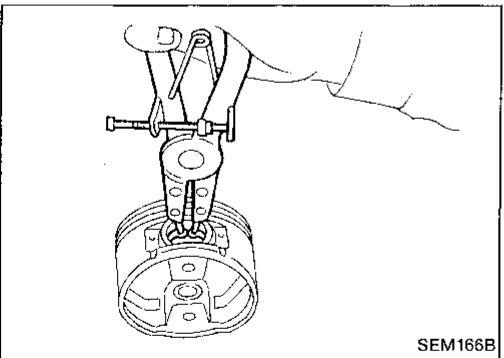

SEM166B

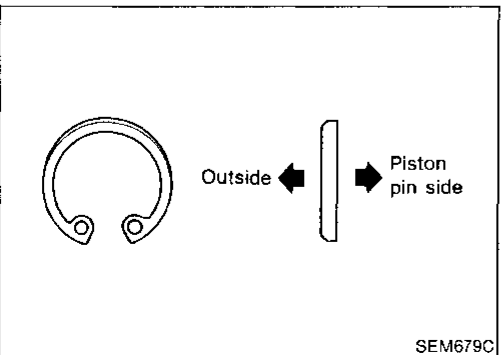

SEM679C

CYLINDER BLOCK

Assembly (Cont'd)

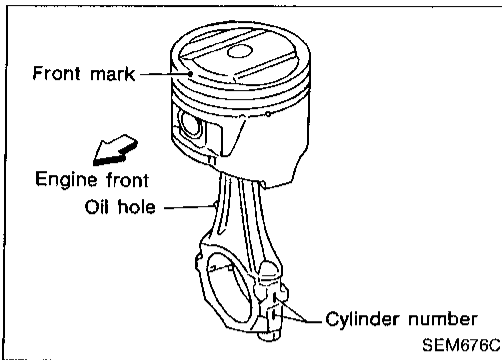

2. Heat piston to 60 to 70°C (140 to 158°F) and assemble piston, piston pin, connecting rod and new snap ring.

- Align the direction of piston and connecting rod.
- Numbers stamped on connecting rod and cap correspond to each cylinder.
- After assembly, make sure connecting rod swings smoothly.

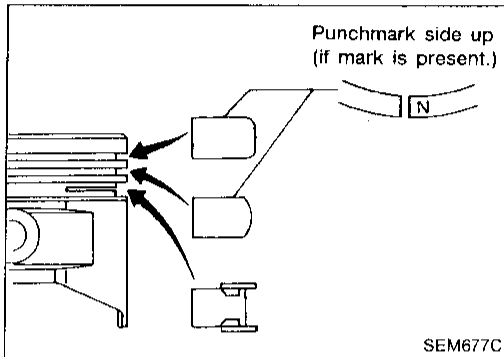

3. Set piston rings as shown.

CAUTION:

- When piston rings are not replaced, make sure that piston rings are mounted in their original positions.
- When replacing piston rings, these without punchmarks, present, piston rings can be mounted with either side up.

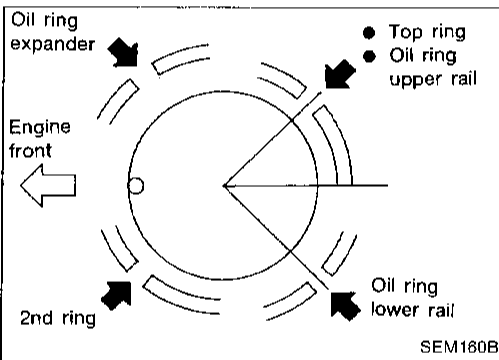

- Align piston rings so that end gaps are positioned as shown in the figure.

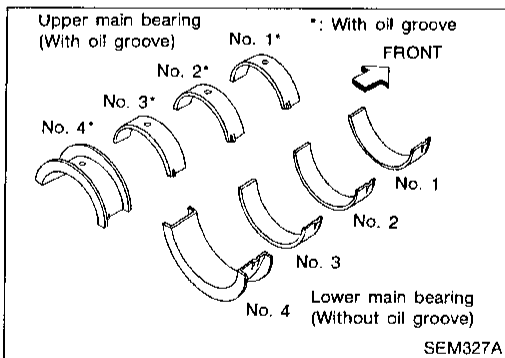

CRANKSHAFT

1. Set main bearings in their proper positions on cylinder block and main bearing cap.

- Confirm that correct main bearings are used. Refer to "Inspection" (EM-45).
- Apply engine oil to bearing surfaces.

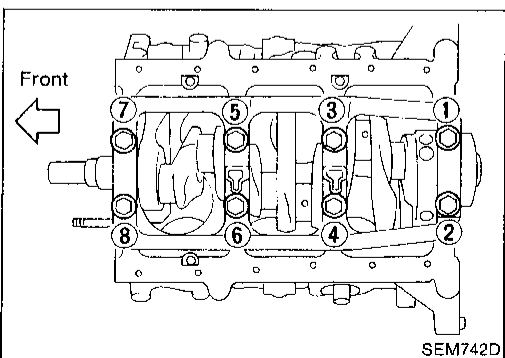

2. Install crankshaft and main bearing caps and tighten bolts to the specified torque.

- Prior to tightening bearing cap bolts, shift crankshaft back and forth to properly seat the bearing cap.
- Tighten bearing cap bolts gradually in two or three stages. Start with center bearing and move outward sequentially.
- After securing bearing cap bolts, make sure crankshaft turns smoothly by hand.
- Lubricate threads and seat surfaces of the bolts with new engine oil.

CYLINDER BLOCK

Assembly (Cont'd)

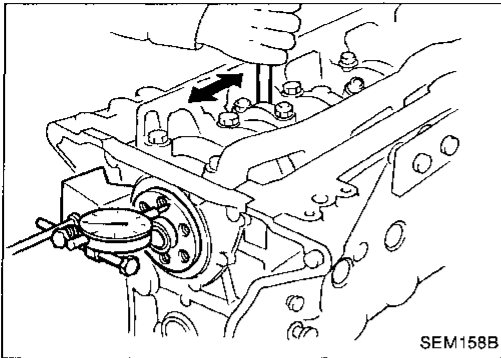

3. Measure crankshaft end play.

Crankshaft end play:

Standard

0.05 - 0.18 mm (0.0020 - 0.0071 in)

Limit

0.30 mm (0.0118 in)

If beyond the limit, replace bearing with a new one.

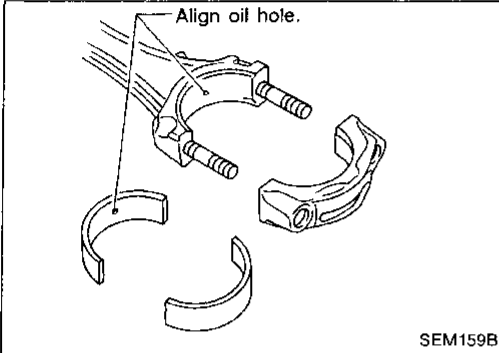

4. Install connecting rod bearings in connecting rods and connecting rod caps.

● **Confirm that correct bearings are used.**

Refer to "Inspection" (EM-47).

● Install bearings so that oil hole in connecting rod aligns with oil hole of bearing.

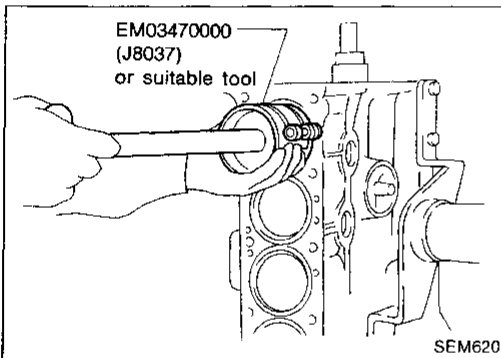

5. Install pistons with connecting rods.

a. Install them into corresponding cylinders with Tool.

● **Be careful not to scratch cylinder wall by connecting rod.**

● **Arrange so that front mark on piston head faces toward front of engine.**

● **Apply new engine oil to bolt threads and bearing surfaces.**

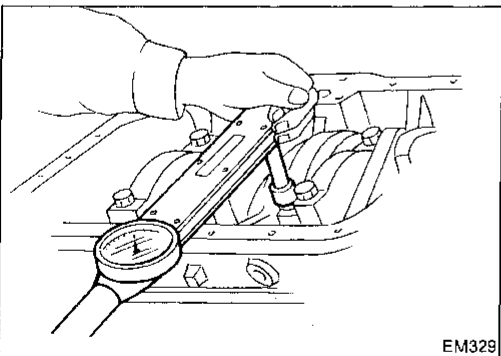

b. Install connecting rod bearing caps.

● **Lubricate threads and seat surfaces with new engine oil.**

Tighten connecting rod bearing cap nuts to the specified torque.

 **Connecting rod bearing nut**

(1) Tighten to 14 to 16 N·m

(1.4 to 1.6 kg-m, 10 to 12 ft-lb).

(2) Tighten to 59 to 65 N·m

(6.0 to 6.6 kg-m, 43 to 48 ft-lb)

or if you have an angle wrench, tighten bolts 60 to 65 degrees clockwise.

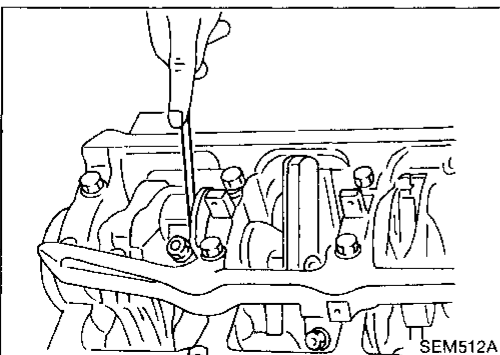

6. Measure connecting rod side clearance.

Connecting rod side clearance:

Standard

0.20 - 0.35 mm (0.0079 - 0.0138 in)

Limit

0.40 mm (0.0157 in)

If beyond the limit, replace connecting rod and/or crankshaft.

GI

MA

EM

LC

EC

FE

AT

PD

FA

RA

BR

ST

RS

BT

HA

EL

IDX

SERVICE DATA AND SPECIFICATIONS (SDS)

General Specifications

Cylinder arrangement	V-6	
Displacement	cm ³ (cu in)	2,960 (180.62)
Bore and stroke	mm (in)	87 × 83 (3.43 × 3.27)
Valve arrangement	DOHC	
Firing order	1-2-3-4-5-6	
Number of piston rings		
Compression	2	
Oil	1	
Number of main bearings	4	
Compression ratio	10.5	

COMPRESSION PRESSURE

Unit: kPa (kg/cm², psi)/300 rpm

Compression pressure	
Standard	1,285 (13.1, 186)
Minimum	981 (10.0, 142)
Differential limit between cylinders	98 (1.0, 14)

Cylinder number

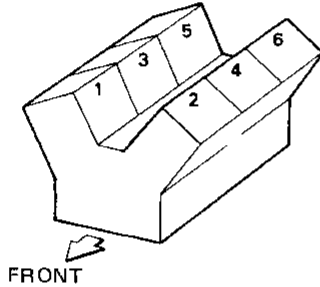

SEM713A

SERVICE DATA AND SPECIFICATIONS (SDS)

Inspection and Adjustment

CYLINDER HEAD

Unit: mm (in)		
	Standard	Limit
Head surface distortion	Less than 0.05 (0.0020)	0.1 (0.004)

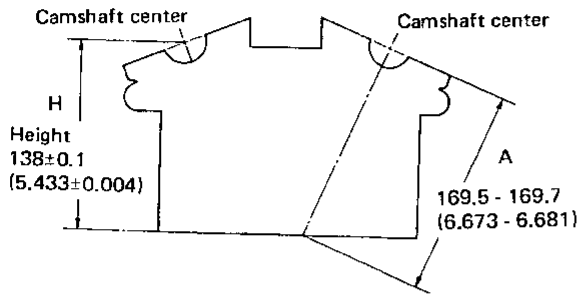

SEM889D

VALVE

Unit: mm (in)

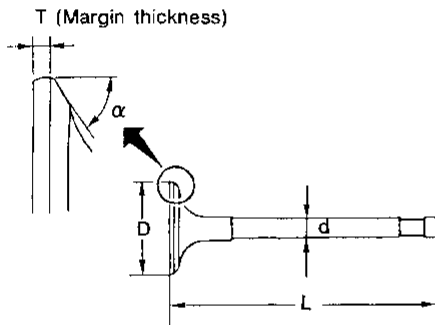

SEM188

Valve head diameter "D"	
Intake	34.0 - 34.2 (1.339 - 1.346)
Exhaust	29.5 - 29.7 (1.161 - 1.169)
Valve length "L"	
Intake	102.95 - 103.45 (4.0531 - 4.0728)
Exhaust	103.45 - 103.95 (4.0728 - 4.0925)
Valve stem diameter "d"	
Intake	5.965 - 5.980 (0.2348 - 0.2354)
Exhaust	5.945 - 5.960 (0.2341 - 0.2346)
Valve seat angle " α "	
Intake	45°15' - 45°45'
Exhaust	
Valve margin "T"	
Intake	1.15 - 1.45 (0.0453 - 0.0571)
Exhaust	1.35 - 1.65 (0.0531 - 0.0650)
Valve margin "T" limit	
More than 0.5 (0.020)	
Valve stem end surface grinding limit	
Less than 0.2 (0.008)	
Valve clearance	
Intake	0 (0)
Exhaust	0 (0)

Valve spring

Free height	mm (in)	43.1 (1.697)
Pressure N (kg, lb) at height mm (in)	Standard	536.4 (54.7, 120.6) at 26.5 (1.043)
	Limit	452.79 (46.17, 101.80) at 26.5 (1.043)
Out-of-square	mm (in)	Less than 1.8 (0.071)

Hydraulic lash adjuster (HLA)

Unit: mm (in)	
HLA outer diameter	30.955 - 30.965 (1.2187 - 1.2191)
HLA guide inner diameter	31.000 - 31.020 (1.2205 - 1.2213)
Clearance between HLA and HLA guide	0.035 - 0.065 (0.0014 - 0.0026)

Valve guide

Unit: mm (in)		
	Standard	Service
Valve guide		
Outer diameter	10.023 - 10.034 (0.3946 - 0.3950)	10.223 - 10.234 (0.4025 - 0.4029)
Valve guide		
Inner diameter (Finished size)	6.000 - 6.018 (0.2362 - 0.2369)	
Cylinder head valve guide hole diameter	9.975 - 9.996 (0.3927 - 0.3935)	10.175 - 10.196 (0.4006 - 0.4014)
Interference fit of valve guide		
0.027 - 0.059 (0.0011 - 0.0023)		
Standard		
Stem to guide clearance	Intake	0.10 (0.0039)
	Exhaust	
Valve deflection limit	—	0.20 (0.0079)

SERVICE DATA AND SPECIFICATIONS (SDS)

Inspection and Adjustment (Cont'd)

VALVE SEAT

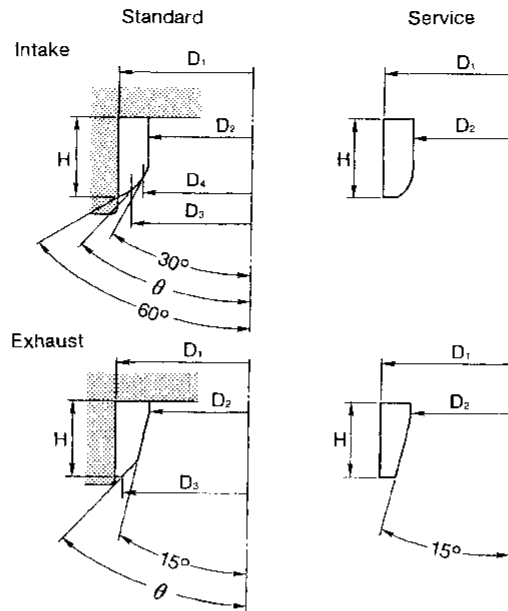

SEM529C

Unit: mm (in)

		Standard	Service*
Cylinder head seat recess diameter (D_1)	In.	36.000 - 36.016 (1.4173 - 1.4179)	36.500 - 36.516 (1.4370 - 1.4376)
	Ex.	31.500 - 31.516 (1.2402 - 1.2408)	32.000 - 32.016 (1.2598 - 1.2605)
Valve seat interference fit	In.	0.081 - 0.113 (0.0032 - 0.0044)	
	Ex.	0.064 - 0.096 (0.0025 - 0.0038)	
Valve seat outer diameter (D_1)	In.	36.097 - 36.113 (1.4211 - 1.4218)	36.597 - 36.613 (1.4408 - 1.4415)
	Ex.	31.580 - 31.596 (1.2433 - 1.2439)	32.080 - 32.096 (1.2630 - 1.2636)
Valve seat inner diameter (D_2)	In.	29.85 - 30.15 (1.1752 - 1.1870)	
	Ex.	24.35 - 24.65 (0.9587 - 0.9705)	
Height (H)	In.	5.9 - 6.0 (0.232 - 0.236)	5.35 - 5.45 (0.2106 - 0.2146)
	Ex.	5.9 - 6.0 (0.232 - 0.236)	5.9 - 6.0 (0.232 - 0.236)
Face angle (θ)	In.	45°	
	Ex.	45°	
Face inner diameter (D_4)	In.	31.5 (1.240)	*: Valve seat surface must be corrected to specified value.
Face diameter (D_3)	In.	33.6 - 33.8 (1.323 - 1.331)	
	Ex.	28.9 - 29.1 (1.138 - 1.146)	

SERVICE DATA AND SPECIFICATIONS (SDS)

Inspection and Adjustment (Cont'd)

PISTON, PISTON RING AND PISTON PIN

Available piston

Unit: mm (in)

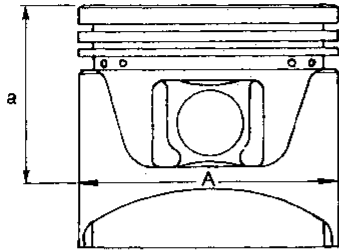

SEM740D

Piston skirt diameter
"A"

Standard

Grade No. 1	86.975 - 86.985 (3.4242 - 3.4246)
Grade No. 2	86.985 - 86.995 (3.4246 - 3.4250)
Grade No. 3	86.995 - 87.005 (3.4250 - 3.4254)
0.25 (0.0098) oversize (Service)	87.225 - 87.275 (3.4340 - 3.4360)
0.50 (0.0197) oversize (Service)	87.475 - 87.525 (3.4439 - 3.4459)
"a" dimension	48.0 (1.890)
Piston pin hole diameter	21.987 - 21.999 (0.8656 - 0.8661)
Piston clearance to cylinder block	0.015 - 0.035 (0.0006 - 0.0014)

Piston ring

Unit: mm (in)

	Standard	Limit
Side clearance	Top	0.1 (0.004)
	2nd	
	Oil	0.2 (0.008)
End gap	Top	1.0 (0.039)
	2nd	
	Oil (rail ring)	

Piston pin

Unit: mm (in)

Piston pin outer diameter	21.989 - 22.001 (0.8657 - 0.8662)
Interference fit of piston pin to piston	-0.004 to 0 (-0.0002 to 0)
Piston pin to connecting rod bushing clearance	0.005 - 0.017 (0.0002 - 0.0007)

Values measured at ambient temperature of 20°C (68°F)

CONNECTING ROD

Unit: mm (in)

Center distance	154.1 - 154.2 (6.067 - 6.071)	
Bend [per 100 (3.94) length]	0.15 (0.0059)	
Limit		
Torsion [per 100 (3.94) length]	0.3 (0.012)	
Limit		
Piston pin bushing inner diameter*	22.000 - 22.012 (0.8661 - 0.8666)	
Connecting rod big end inner diameter	53.000 - 53.013 (2.0866 - 2.0871)	
Side clearance	Standard	0.20 - 0.35 (0.0079 - 0.0138)
	Limit	0.40 (0.0157)

*: After installing in connecting rod

SERVICE DATA AND SPECIFICATIONS (SDS)

Inspection and Adjustment (Cont'd)

CAMSHAFT AND CAMSHAFT BEARING

Unit: mm (in)

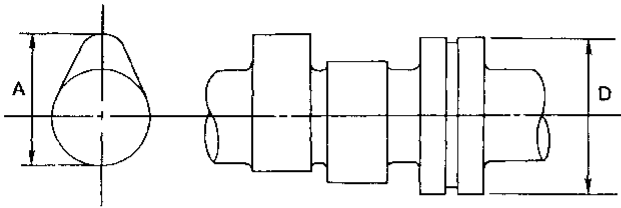

SEM568A

	Standard	Max. tolerance
Camshaft journal to bearing clearance	0.045 - 0.086 (0.0018 - 0.0034)	0.15 (0.0059)
Inner diameter of camshaft bearing	28.000 - 28.021 (1.1024 - 1.1032)	—
Outer diameter of camshaft journal	27.935 - 27.955 (1.0998 - 1.1006)	—
Camshaft runout [TIR*]	Less than 0.04 (0.0016)	0.1 (0.004)
Camshaft end play	0.03 - 0.08 (0.0012 - 0.0031)	—

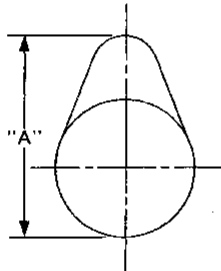

EM671

Cam height "A"	
Intake	39.605 - 39.795 (1.5592 - 1.5667)
Exhaust	40.405 - 40.595 (1.5907 - 1.5982)
Wear limit of cam height	0.15 (0.0059)

*Total indicator reading

Valve timing

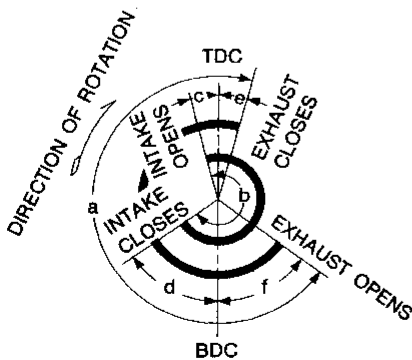

Unit: degree
EM120

a	b	c	d	e	f
240	232	3	49	5	55

CYLINDER BLOCK

Unit: mm (in)

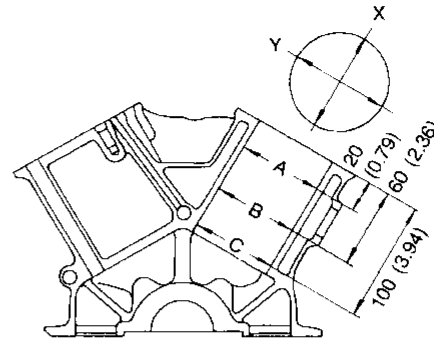

SEM733E

Surface flatness	
Standard	Less than 0.03 (0.0012)
Limit	0.10 (0.0039)
Cylinder bore	
Inner diameter	
Standard	
Grade No. 1	87.000 - 87.010 (3.4252 - 3.4256)
Grade No. 2	87.010 - 87.020 (3.4256 - 3.4260)
Grade No. 3	87.020 - 87.030 (3.4260 - 3.4264)
Wear limit	0.20 (0.0079)
Out-of-round (X - Y)	Less than 0.015 (0.0006)
Taper (A - B - C)	Less than 0.015 (0.0006)
Main journal inner diameter "dm"	
Grade No. 0	66.645 - 66.654 (2.6238 - 2.6242)
Grade No. 1	66.654 - 66.663 (2.6242 - 2.6245)
Grade No. 2	66.663 - 66.672 (2.6245 - 2.6249)
Difference in inner diameter between cylinders	
Standard	Less than 0.05 (0.0020)

SERVICE DATA AND SPECIFICATIONS (SDS)

Inspection and Adjustment (Cont'd)

CRANKSHAFT

Unit: mm (in)

Main journal dia. "Dm"	
Grade No. 0	62.967 - 62.975 (2.4790 - 2.4793)
Grade No. 1	62.959 - 62.967 (2.4787 - 2.4790)
Grade No. 2	62.951 - 62.959 (2.4784 - 2.4787)
Pin journal dia. "Dp"	
Grade No. 0	49.968 - 49.974 (1.9672 - 1.9675)
Grade No. 1	49.962 - 49.968 (1.9670 - 1.9672)
Grade No. 2	49.955 - 49.962 (1.9667 - 1.9670)
Center distance "r"	41.47 - 41.53 (1.6327 - 1.6350)
Out-of-round (X - Y)	
Standard	Less than 0.005 (0.0002)
Limit	0.02 (0.0008)
Taper (A - B)	
Standard	Less than 0.005 (0.0002)
Limit	0.02 (0.0008)
Runout [TIR]	
Standard	Less than 0.10 (0.0039)
Free end play	
Standard	0.05 - 0.18 (0.0020 - 0.0071)
Limit	0.30 (0.0118)

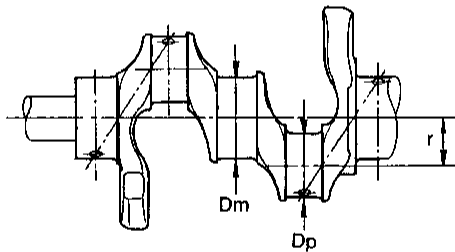

SEM645

Out-of-round (X - Y)
Taper (A - B)

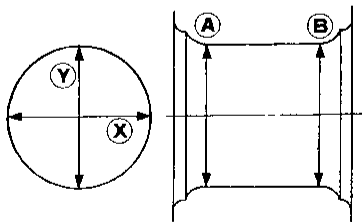

EM715

AVAILABLE MAIN BEARING

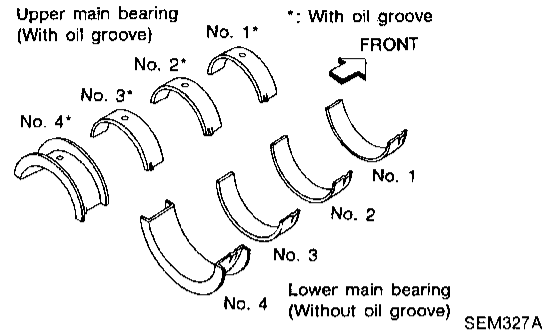

No. 1 main bearing

Grade number	Thickness "T" mm (in)	Width "W" mm (in)	Identification color
0	1.817 - 1.821 (0.0715 - 0.0717)		Black
1	1.821 - 1.825 (0.0717 - 0.0719)		Brown
2	1.825 - 1.829 (0.0719 - 0.0720)	22.4 - 22.6 (0.882 - 0.890)	Green
3	1.829 - 1.833 (0.0720 - 0.0722)		Yellow
4	1.833 - 1.837 (0.0722 - 0.0723)		Blue

No. 2 and 3 main bearing

Grade number	Thickness "T" mm (in)	Width "W" mm (in)	Identification color
0	1.817 - 1.821 (0.0715 - 0.0717)		Black
1	1.821 - 1.825 (0.0717 - 0.0719)		Brown
2	1.825 - 1.829 (0.0719 - 0.0720)	18.9 - 19.1 (0.744 - 0.752)	Green
3	1.829 - 1.833 (0.0720 - 0.0722)		Yellow
4	1.833 - 1.837 (0.0722 - 0.0723)		Blue

SERVICE DATA AND SPECIFICATIONS (SDS)

Inspection and Adjustment (Cont'd)

No. 4 main bearing

Grade number	Thickness "T" mm (in)	Identification color
0	1.817 - 1.821 (0.0715 - 0.0717)	Black
1	1.821 - 1.825 (0.0717 - 0.0719)	Brown
2	1.825 - 1.829 (0.0719 - 0.0720)	Green
3	1.829 - 1.833 (0.0720 - 0.0722)	Yellow
4	1.833 - 1.837 (0.0722 - 0.0723)	Blue

Undersize

Unit: mm (in)		
	Thickness	Main journal diameter "Dm"
0.25 (0.0098)	1.948 - 1.956 (0.0767 - 0.0770)	Grind so that bearing clearance is the specified value.

AVAILABLE CONNECTING ROD BEARING

Connecting rod bearing

Grade number	Thickness "T" mm (in)	Identification color
0	1.496 - 1.499 (0.0589 - 0.0590)	No paint
1	1.499 - 1.502 (0.0590 - 0.0591)	Brown
2	1.502 - 1.505 (0.0591 - 0.0593)	Green
3	1.505 - 1.508 (0.0593 - 0.0594)	Yellow

Undersize

Unit: mm (in)		
	Thickness	Crank pin journal diameter "Dp"
0.08 (0.0031)	1.540 - 1.548 (0.0606 - 0.0609)	Grind so that bearing clearance is the specified value.
0.12 (0.0047)	1.560 - 1.568 (0.0614 - 0.0617)	
0.25 (0.0098)	1.625 - 1.633 (0.0640 - 0.0643)	

MISCELLANEOUS COMPONENTS

Unit: mm (in)	
Drive plate	
Runout [TIR]*	Less than 0.15 (0.0059)

*Total indicator reading

Bearing clearance

Unit: mm (in)	
Main bearing clearance	
Standard	0.028 - 0.055 (0.0011 - 0.0022)
Limit	0.090 (0.0035)
Connecting rod bearing clearance	
Standard	0.028 - 0.048 (0.0011 - 0.0019)
Limit	0.090 (0.0035)