

ACCELERATOR CONTROL, FUEL & EXHAUST SYSTEMS

SECTION **FE**

GI

MA

EM

LC

EC

FE

AT

PD

FA

RA

BR

ST

RS

BT

HA

FR

DX

CONTENTS

ACCELERATOR CONTROL SYSTEM 2	Fuel Tank..... 3
Adjusting Accelerator Wire 2	Fuel Pump and Gauge..... 5
FUEL SYSTEM 3	EXHAUST SYSTEM 6

ACCELERATOR CONTROL SYSTEM

CAUTION:

- When removing accelerator wire, make a mark to indicate lock nut's initial position.
- Check that throttle valve fully opens when accelerator pedal is fully depressed. Also check that it returns to idle position when pedal is released.
- Check accelerator control parts for improper contact with any adjacent parts.
- When connecting accelerator wire, be careful not to twist or scratch its inner wire.
- Refer to "AUTOMATIC SPEED CONTROL DEVICE" in EL section for ASCD wire adjustment.
- Refer to "ON-VEHICLE SERVICE" in AT section for Kickdown switch adjustment.

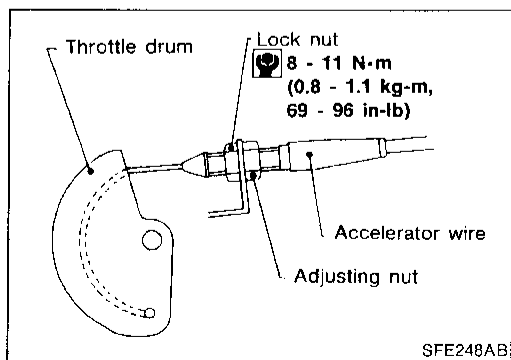
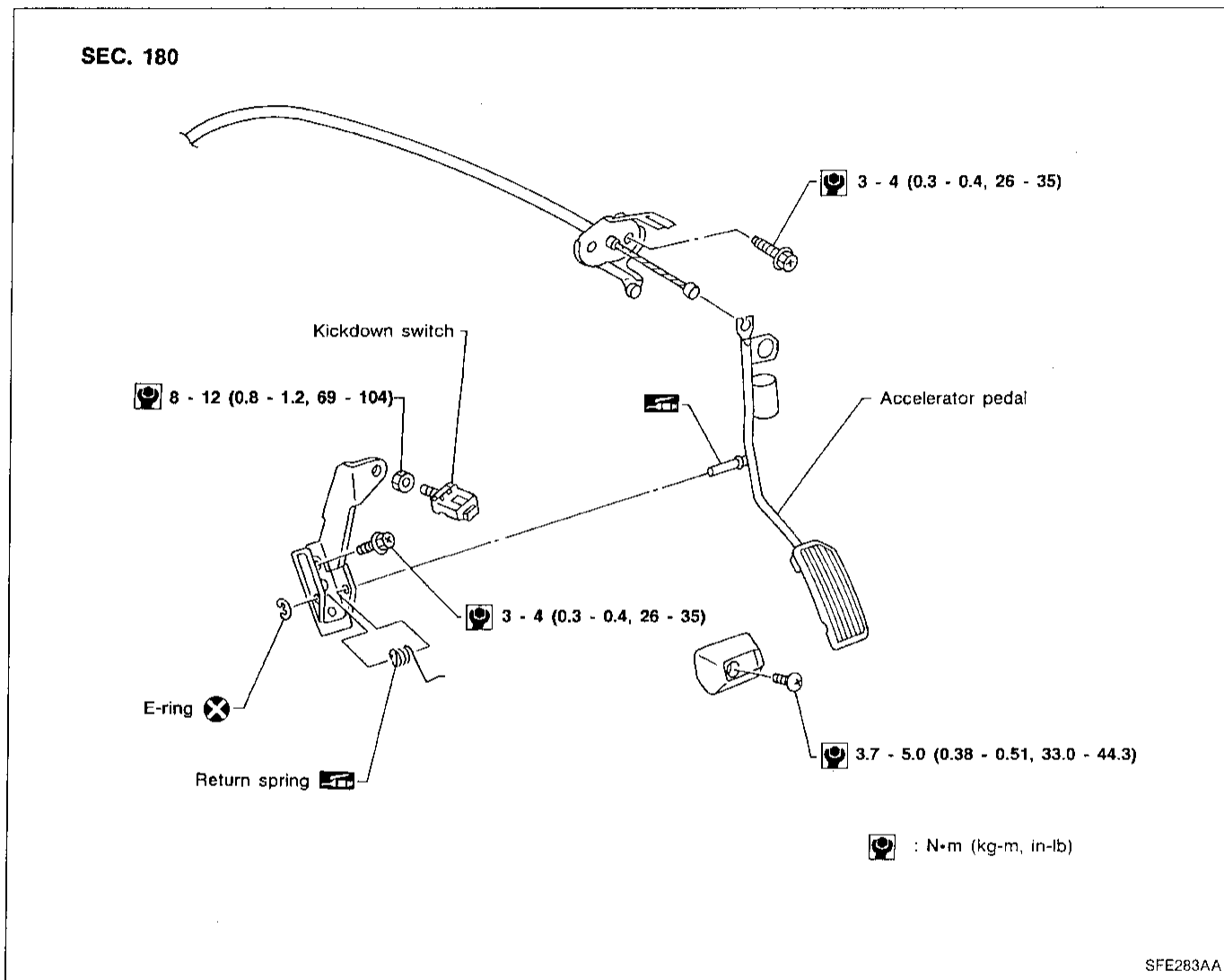

Adjusting Accelerator Wire

CAUTION:

- Make sure the ASCD wire is not pulling the throttle drum.
 - Refer to "AUTOMATIC SPEED CONTROL DEVICE" in EL section for ASCD wire adjustment.
1. Loosen lock nut, and tighten adjusting nut until throttle drum starts to move.
 2. From that position turn back adjusting nut 1.5 to 2 turns, and fasten it with lock nut.

FUEL SYSTEM

WARNING:

- Be sure to furnish workshop with a CO₂ fire extinguisher.
- Do not smoke while servicing fuel system. Keep open flames and sparks away from work area.

CAUTION:

- Before removing fuel line parts carry out the following procedures:
 - a. Put drained fuel in an explosion-proof container and put the lid on securely.
 - b. Release fuel pressure from fuel line. Refer to "Changing Fuel Filter" in MA section.
 - c. Disconnect battery ground cable.
- When installing fuel check valve, be careful of its designated direction. (Refer to "EVAPORATIVE EMISSION SYSTEM" in EC section.)
- Always replace O-ring and clamps with new ones.
- Do not kink or twist tubes when they are being installed.
- Do not tighten hose clamps excessively to avoid damaging hoses.
- After installing tubes, run engine and check for fuel leaks at connections.
- Use only a genuine fuel filler cap as a replacement.

Fuel Tank

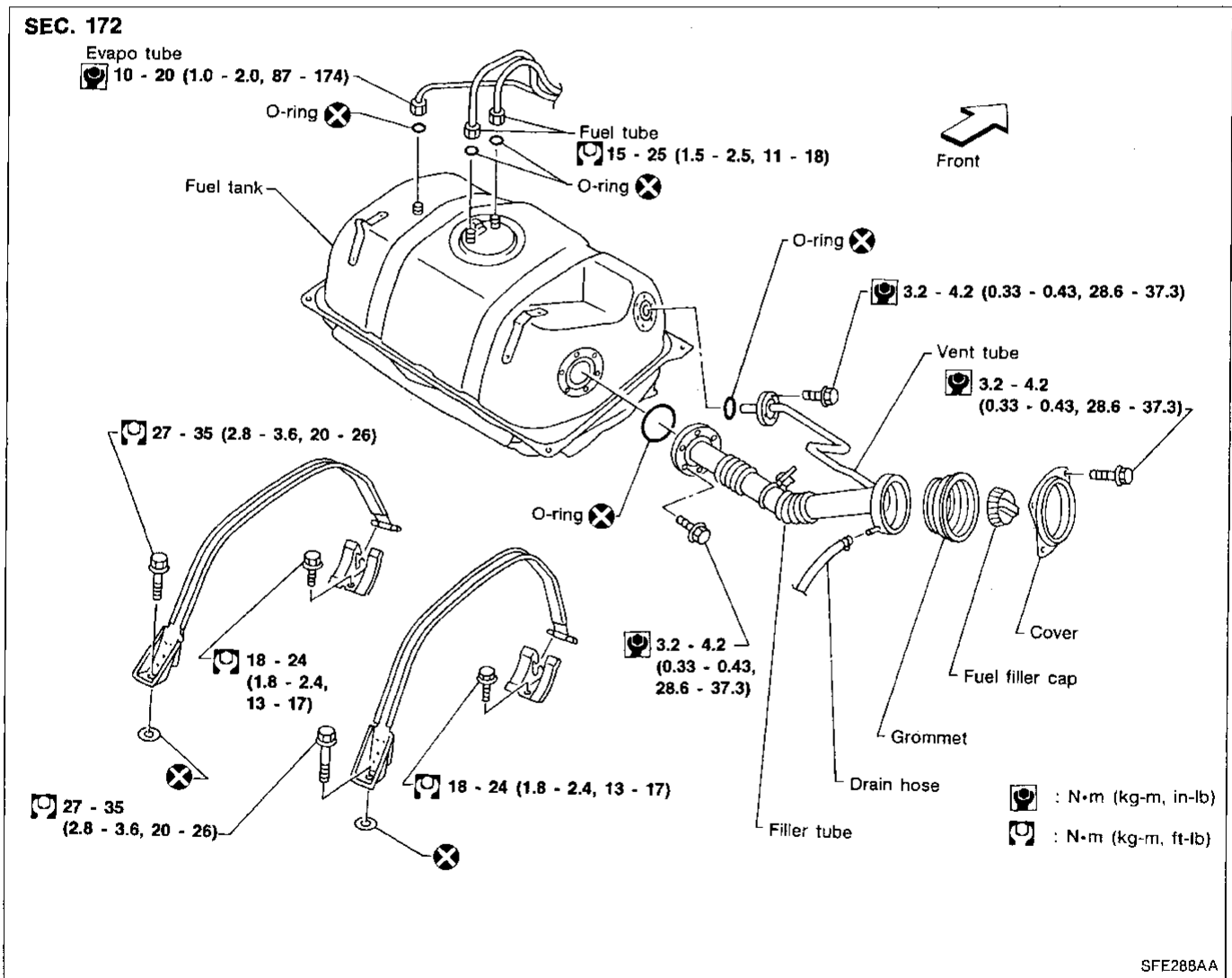

FUEL SYSTEM

Fuel Tank (Cont'd)

REMOVAL

CAUTION:

- Do not disconnect any fuel line unless absolutely necessary.
- Plug pipe openings to prevent entry of dust or dirt.
- Do not pull drain hose as it may become disconnected from grommet on underside of vehicle.

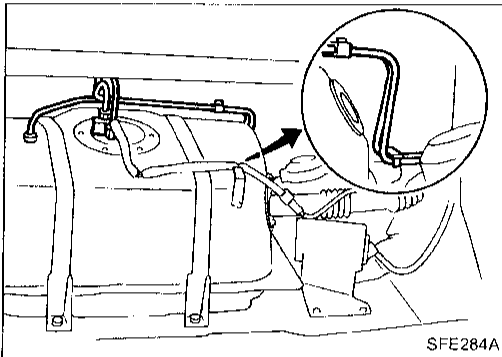

1. Release fuel pressure from fuel line. Refer to "Changing Fuel Filter" in MA section.
2. Remove trunk front finisher. Refer to "Trunk Room Trim", "INTERIOR TRIM" in BT section.
3. Disconnect connector, tubes and clip.

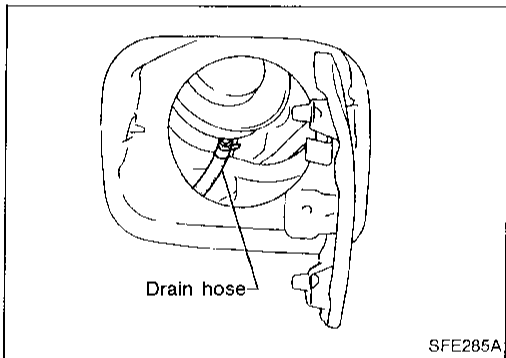

4. Remove cover and grommet.
5. Disconnect drain hose and fasten its end to the body with tape to prevent it from dropping.

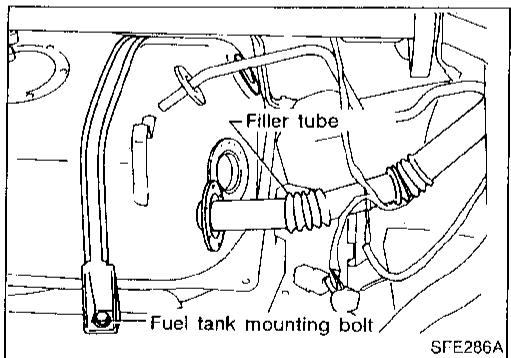

6. Remove filler tube.
7. Remove the two fuel tank mounting bolts, and remove fuel tank.

FUEL SYSTEM

Fuel Tank (Cont'd)

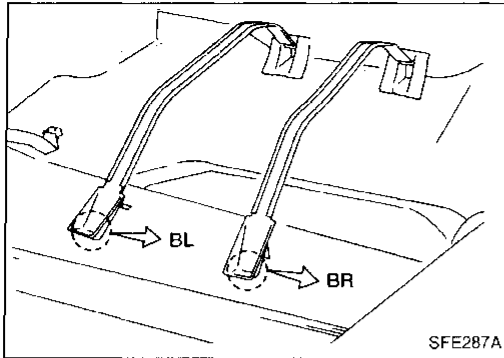

INSTALLATION

- Installation procedure is basically the reverse order of removal.
- Before installing fuel tank, make sure the two mounting bands are set in position. Each band has an identification mark as shown in the figure at left.

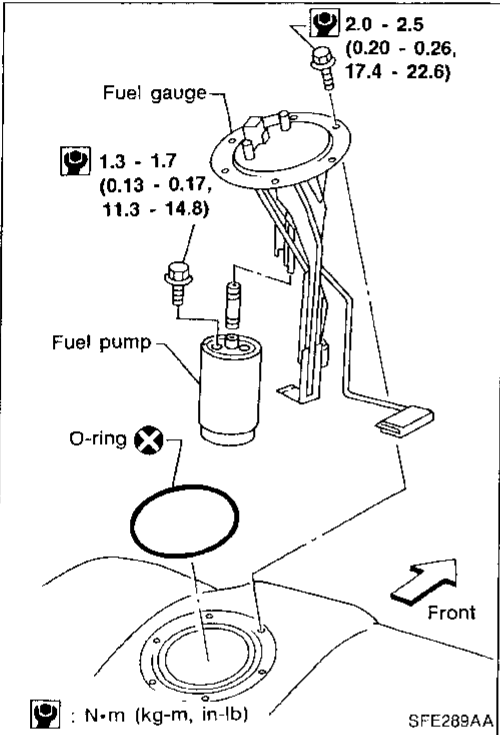

Fuel Pump and Gauge

REMOVAL

1. Release fuel pressure from fuel line. Refer to "Changing Fuel Filter" in MA section.
2. Remove trunk front finisher. Refer to "Trunk Room Trim", "INTERIOR TRIM" in BT section.
3. Disconnect connector and tubes.
4. Remove bolts and remove fuel pump and gauge assembly.
5. Loosen clamp and separate fuel pump and gauge.

INSTALLATION

- Installation procedure is basically the reverse order of removal.

CAUTION:

- Always replace O-ring with a new one.
- Tighten bolts to specified torque. After installation, run engine and check for leaks at connections.

EXHAUST SYSTEM

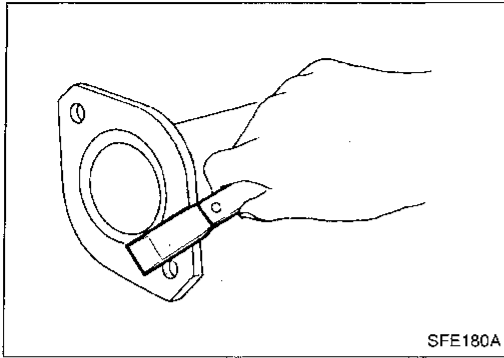

CAUTION:

- When connecting center tube and muffler assembly, use the Genuine Nissan Sealant "Exhaust Sealant Kit 20720-N2226" or an equivalent to eliminate gas leaks at the joint.
- Always replace exhaust gaskets with new ones when reassembling. If gasket is left on flange surface, scrape off completely as shown at left.
- With engine running, check all tube connections for exhaust gas leaks, and entire system for unusual noises.
- Check that mounting brackets and mounting insulator are installed properly and free from undue stress. Improper installation could result in excessive noise or vibration.
- Discard any heated oxygen sensor which has been dropped from a height of more than 0.5 m (19.7 in) onto a hard surface such as a concrete floor; use a new one.

