

## SECTION HA

GI

MA

EM

LC

EC

FE

AT

PD

FA

RA

BR

ST

RS

BT

HA

EL

IDX

## CONTENTS

<b>PRECAUTIONS AND PREPARATION</b> .....	2	Wiring Diagram — A/C — .....	68
Supplemental Restraint System (SRS) "AIR BAG" and "SEAT BELT PRE-TENSIONER" .....	2	<b>SYSTEM DESCRIPTION</b> .....	104
Precautions for Working with HFC-134a (R-134a) .....	2	Overview of Control System .....	104
General Refrigerant Precautions .....	2	Control System Input Components .....	104
Precautions for Refrigerant Connection .....	3	Control System Automatic Amplifier (Auto amp.) .....	108
Precautions for Servicing Compressor .....	4	Control System Output Components .....	110
Special Service Tools .....	4	<b>SERVICE PROCEDURES</b> .....	125
HFC-134a (R-134a) Service Tools and Equipment .....	5	HFC-134a (R-134a) Service Procedure .....	125
Precautions for Service Equipment .....	7	Maintenance of Lubricant Quantity in Compressor .....	127
<b>DESCRIPTION</b> .....	9	Refrigerant Lines .....	129
Refrigeration Cycle .....	9	Checking Refrigerant Leaks .....	130
V-6 Variable Displacement Compressor .....	10	Compressor Mounting .....	132
Component Layout .....	14	Belt Tension .....	132
Discharge Air Flow .....	15	Fast Idle Control Device (FICD) .....	132
Introduction .....	16	Compressor .....	133
Features .....	16	Compressor Clutch .....	133
Control Operation .....	17	<b>SERVICE DATA AND SPECIFICATIONS (SDS)</b> .....	137
<b>TROUBLE DIAGNOSES</b> .....	19	General Specifications .....	137
Contents .....	19	Inspection and Adjustment .....	137

**When you read wiring diagrams:**

- Read GI section, "HOW TO READ WIRING DIAGRAMS".
- See EL section, "POWER SUPPLY ROUTING" for power distribution circuit.

**When you perform trouble diagnoses, read GI section, "HOW TO FOLLOW FLOW CHART IN TROUBLE DIAGNOSES" and "HOW TO PERFORM EFFICIENT DIAGNOSIS FOR AN ELECTRICAL INCIDENT".**

## PRECAUTIONS AND PREPARATION

### Supplemental Restraint System (SRS) "AIR BAG" and "SEAT BELT PRE-TENSIONER"

The Supplemental Restraint System "Air Bag" and "Seat Belt Pre-tensioner", used along with a seat belt, help to reduce the risk or severity of injury to the driver and front passenger in a frontal collision. The Supplemental Restraint System consists of air bag modules (located in the center of the steering wheel and on the instrument panel on the passenger side), seat belt pre-tensioners, a diagnosis sensor unit, warning lamp, wiring harness and spiral cable. Information necessary to service the system safely is included in the **RS section** in this Service Manual.

#### WARNING:

- To avoid rendering the SRS inoperative, which could increase the risk of personal injury or death in the event of a collision which would result in air bag inflation, all maintenance must be performed by an authorized INFINITI dealer.
- Improper maintenance, including incorrect removal and installation of the SRS, can lead to personal injury caused by unintentional activation of the system.
- Do not use electrical test equipment on any circuit related to the SRS unless instructed to in this Service Manual. SRS wiring harnesses are covered with yellow insulation either just before the harness connectors or for the complete harness, for easy identification.

#### WARNING:

### Precautions for Working with HFC-134a (R-134a)

- CFC-12 (R-12) refrigerant and HFC-134a (R-134a) refrigerant are not compatible. These refrigerants must never be mixed, even in the smallest amounts. If the refrigerants are mixed, compressor failure is likely to occur.
- Use only specified lubricant for the HFC-134a (R-134a) A/C system and HFC-134a (R-134a) components. If lubricant other than that specified is used, compressor failure is likely to occur.
- The specified HFC-134a (R-134a) lubricant rapidly absorbs moisture from the atmosphere. The following handling precautions must be observed:
  - a: When removing refrigerant components from a vehicle, immediately cap (seal) the component to minimize the entry of moisture from the atmosphere.
  - b: When installing refrigerant components to a vehicle, do not remove the caps (unseal) until just before connecting the components. Connect all refrigerant loop components as quickly as possible to minimize the entry of moisture into system.
  - c: Only use the specified lubricant from a sealed container. Immediately reseal containers of lubricant. Without proper sealing, lubricant will become moisture saturated and should not be used.
  - d: Avoid breathing A/C refrigerant and lubricant vapor or mist. Exposure may irritate eyes, nose and throat. Remove R-134a from the A/C system, using certified service equipment meeting requirements of SAE J2210 (R-134a recycling equipment), or J2209 (R-134a recovery equipment). If accidental system discharge occurs, ventilate work area before resuming service. Additional health and safety information may be obtained from refrigerant and lubricant manufacturers.
  - e: Do not allow lubricant (Nissan A/C System Oil Type S) to come in contact with styrofoam parts. Damage may result.

#### WARNING:

### General Refrigerant Precautions

- Do not release refrigerant into the air. Use approved recovery/recycling equipment to capture the refrigerant every time an air conditioning system is discharged.
- Always wear eye and hand protection (goggles and gloves) when working with any refrigerant or air conditioning system.
- Do not store or heat refrigerant containers above 52°C (125°F).
- Do not heat a refrigerant container with an open flame; if container warming is required, place the bottom of the container in a warm pail of water.
- Do not intentionally drop, puncture, or incinerate refrigerant containers.
- Keep refrigerant away from open flames: poisonous gas will be produced if refrigerant burns.
- Refrigerant will displace oxygen, therefore be certain to work in well ventilated areas to prevent suffocation.
- Do not introduce compressed air to any refrigerant container or refrigerant component.

# PRECAUTIONS AND PREPARATION

## Precautions for Refrigerant Connection

### WARNING:

Make sure all refrigerant is discharged into the recycling equipment and the pressure in the system is less than atmospheric pressure. Then gradually loosen the discharge side hose fitting and remove it.

### CAUTION:

When replacing or cleaning refrigerant cycle components, observe the following.

- When the compressor is removed, store it in the same position as it is when mounted on the car. Failure to do so will cause lubricant to enter the low pressure chamber.
- When connecting tubes, always use a torque wrench and a back-up wrench.
- After disconnecting tubes, immediately plug all openings to prevent entry of dirt and moisture.
- When installing an air conditioner in the vehicle, connect the pipes as the final stage of the operation. Do not remove the seal caps of pipes and other components until just before required for connection.
- Allow components stored in cool areas to warm to working area temperature before removing seal caps. This prevents condensation from forming inside A/C components.
- Thoroughly remove moisture from the refrigeration system before charging the refrigerant.
- Always replace used O-rings.
- When connecting tube, apply lubricant to portions shown in illustration. Be careful not to apply lubricant to threaded portion.

Lubricant name: Nissan A/C System Oil Type S

Part number: KLH00-PAGSO

- O-ring must be closely attached to inflated portion of tube.
- After inserting tube into union until O-ring is no longer visible, tighten nut to specified torque.
- After connecting line, conduct leak test and make sure that there is no leakage from connections. When the gas leaking point is found, disconnect that line and replace the O-ring. Then tighten connections of seal seat to the specified torque.

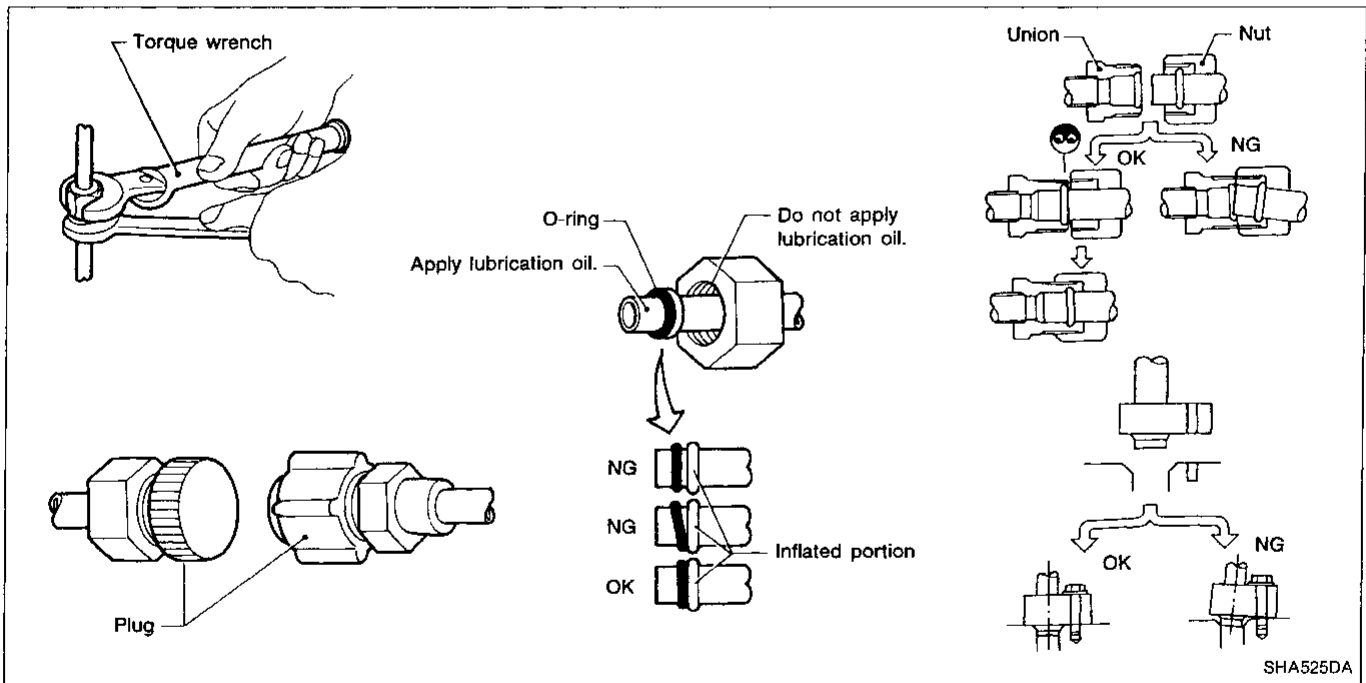

# PRECAUTIONS AND PREPARATION

## Precautions for Servicing Compressor

- Plug all openings to prevent moisture and foreign matter from entering.
- When the compressor is removed, store it in the same position as it is when mounted on the car.
- When replacing or repairing compressor, follow "Maintenance of Lubricant Quantity in Compressor" exactly. Refer to HA-127.
- Keep friction surfaces between clutch and pulley clean. If the surface is contaminated, with lubricant, wipe it off by using a clean waste cloth moistened with thinner.
- After compressor service operation, turn the compressor shaft by hand more than five turns in both directions. This will equally distribute lubricant inside the compressor. After the compressor is installed, let the engine idle and operate the compressor for one hour.
- After replacing the compressor magnet clutch, apply voltage to the new one and check for normal operation.

## Special Service Tools

The actual shapes of Kent-Moore tools may differ from those of special service tools illustrated here.

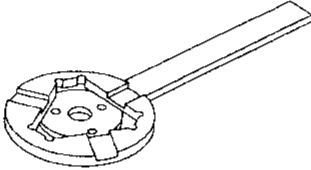
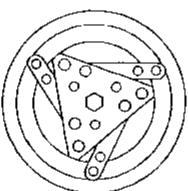
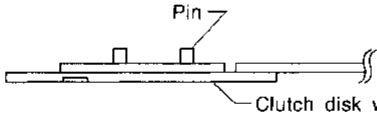
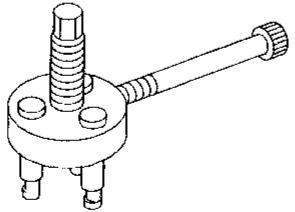
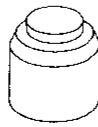
Tool number (Kent-Moore No.) Tool name	Description
KV99106100 (J-41260) Clutch disc wrench	<div style="text-align: right;">Removing center bolt</div> <div style="text-align: center;">  <p>NT232</p>  <p>When replacing the magnet clutch in the above compressor, use a clutch disc wrench with the pin side on the clutch disc to remove it.</p>  <p>Pin Clutch disc wrench</p> <p>NT378</p> </div>
KV99232340 (J-38874) or KV992T0001 ( — ) Clutch disc puller	<div style="text-align: right;">Removing clutch disc</div> <div style="text-align: center;">  <p>NT376</p> </div>
KV99106200 (J-41261) Pulley installer	<div style="text-align: right;">Installing pulley</div> <div style="text-align: center;">  <p>NT235</p> </div>

## PRECAUTIONS AND PREPARATION

### HFC-134a (R-134a) Service Tools and Equipment

Never mix HFC-134a refrigerant and/or its specified lubricant with CFC-12 (R-12) refrigerant and/or its lubricant.

Separate and non-interchangeable service equipment must be used for handling each type of refrigerant/lubricant.

Refrigerant container fittings, service hose fittings and service equipment fittings (equipment which handles refrigerant and/or lubricant) are different between CFC-12 (R-12) and HFC-134a (R-134a). This is to avoid mixed use of the refrigerants/lubricant.

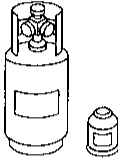
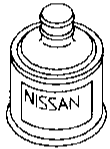
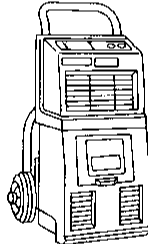
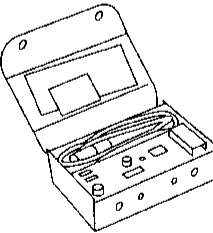
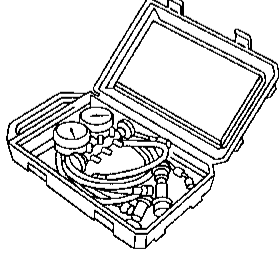

Adapters that convert one size fitting to another must never be used: refrigerant/lubricant contamination will occur and compressor failure will result.

Tool number (Kent-Moore No.) Tool name	Description	Note
HFC-134a (R-134a) refrigerant	 NT196	Container color: Light blue Container marking: HFC-134a (R-134a) Fitting size: Thread size <ul style="list-style-type: none"> <li>● large container 1/2"-16 ACME</li> </ul>
KLH00-PAGS0 ( — ) Nissan A/C System Oil Type S	 NT197	Type: Poly alkylene glycol oil (PAG), type S Application: HFC-134a (R-134a) swash plate (piston) compressors (Nissan only) Lubricity: 40 ml (1.4 US fl oz, 1.4 Imp fl oz)
(J-39500-INF) Recovery/Recycling Recharging equipment (ACR4)	 NT195	Function: Refrigerant Recovery and Recycling and Recharging
(J-39400) Electrical leak detector	 NT198	Power supply: <ul style="list-style-type: none"> <li>● DC 12 V (Cigarette lighter)</li> </ul>
(J-39183) Manifold gauge set (with hoses and couplers)	 NT199	Identification: <ul style="list-style-type: none"> <li>● The gauge face indicates R-134a.</li> </ul> Fitting size: Thread size <ul style="list-style-type: none"> <li>● 1/2"-16 ACME</li> </ul>

GI  
MA  
EM  
LC  
EC  
FE  
AT  
PD  
FA  
RA  
BR  
ST  
RS  
BT  
HA  
EL  
DX

## PRECAUTIONS AND PREPARATION

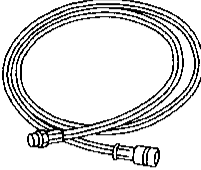
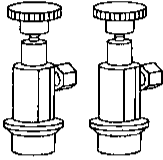
### HFC-134a (R-134a) Service Tools and Equipment (Cont'd)

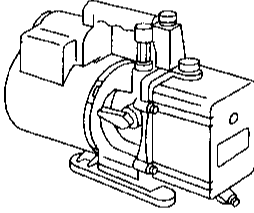
Tool number (Kent-Moore No.) Tool name	Description	Note
Service hoses <ul style="list-style-type: none"> <li>● High side hose (J-39501-72)</li> <li>● Low side hose (J-39502-72)</li> <li>● Utility hose (J-39476-72)</li> </ul>	 NT201	Hose color: <ul style="list-style-type: none"> <li>● Low hose: Blue with black stripe</li> <li>● High hose: Red with black stripe</li> <li>● Utility hose: Yellow with black stripe or green with black stripe</li> </ul> Hose fitting to gauge: <ul style="list-style-type: none"> <li>● 1/2''-16 ACME</li> </ul>
Service couplers <ul style="list-style-type: none"> <li>● High side coupler (J-39500-20)</li> <li>● Low side coupler (J-39500-24)</li> </ul>	 NT202	Hose fitting to service hose: <ul style="list-style-type: none"> <li>● M14 x 1.5 fitting is optional or permanently attached.</li> </ul>
(J-39650) Refrigerant weight scale	 NT200	For measuring of refrigerant Fitting size: Thread size <ul style="list-style-type: none"> <li>● 1/2''-16 ACME</li> </ul>
(J-39649) Vacuum pump (Including the isolator valve)	 NT203	Capacity: <ul style="list-style-type: none"> <li>● Air displacement: 4 CFM</li> <li>● Micron rating: 20 microns</li> <li>● Oil capacity: 482 g (17 oz)</li> </ul> Fitting size: Thread size <ul style="list-style-type: none"> <li>● 1/2''-16 ACME</li> </ul>

# PRECAUTIONS AND PREPARATION

## Precautions for Service Equipment

### RECOVERY/RECYCLING EQUIPMENT

Follow the manufacturer's instructions for machine operation and machine maintenance. Never introduce any refrigerant other than that specified into the machine. GI

### ELECTRONIC LEAK DETECTOR

Follow the manufacturer's instructions for tester operation and tester maintenance. MA  
EM

### VACUUM PUMP

The lubricant contained inside the vacuum pump is not compatible with the specified lubricant for HFC-134a (R-134a) A/C systems. The vent side of the vacuum pump is exposed to atmospheric pressure. So the vacuum pump lubricant may migrate out of the pump into the service hose. This is possible when the pump is switched off after evacuation (vacuuming) and hose is connected to it. LC  
EC  
FE

To prevent this migration, use a manual valve situated near the hose-to-pump connection, as follows. AT

- Usually vacuum pumps have a manual isolator valve as part of the pump. Close this valve to isolate the service hose from the pump. PD
- For pumps without an isolator, use a hose equipped with a manual shut-off valve near the pump end. Close the valve to isolate the hose from the pump. FA
- If the hose has an automatic shut off valve, disconnect the hose from the pump: as long as the hose is connected, the valve is open and lubricating oil may migrate. RA

Some one-way valves open when vacuum is applied and close under a no vacuum condition. Such valves may restrict the pump's ability to pull a deep vacuum and are not recommended. BR

### MANIFOLD GAUGE SET

Be certain that the gauge face indicates R-134a or 134a. Make sure the gauge set has 1/2"-16 ACME threaded connections for service hoses. Confirm the set has been used only with refrigerant HFC-134a (R-134a) along with specified lubricant. ST  
RS

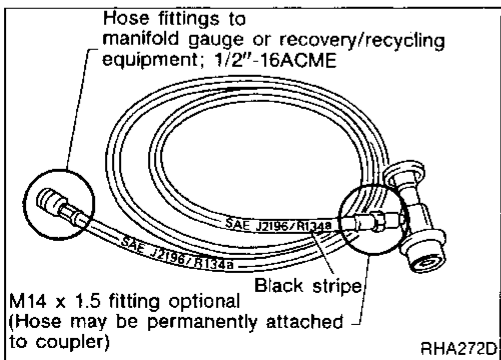
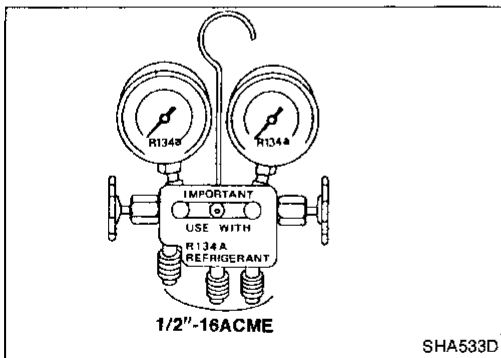
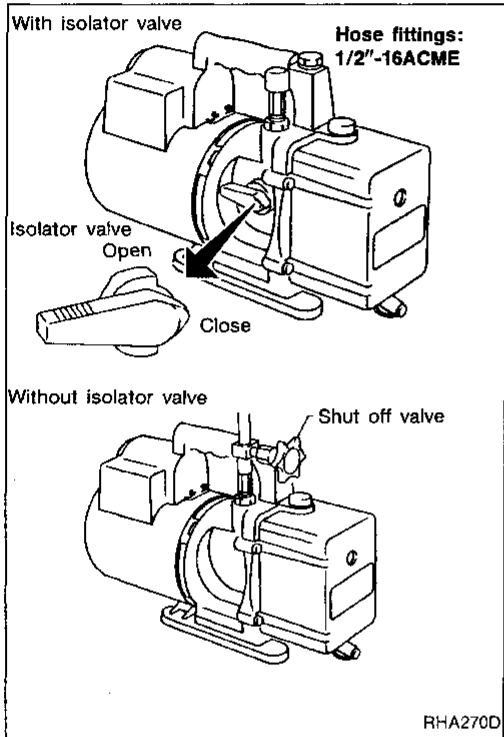

### SERVICE HOSES

Be certain that the service hoses display the markings described (colored hose with black stripe). All hoses must include positive shut off devices (either manual or automatic) near the end of the hoses opposite the manifold gauge. BT  
HA  
EL  
IDX

## PRECAUTIONS AND PREPARATION

### Precautions for Service Equipment (Cont'd)

#### SERVICE COUPLERS

Never attempt to connect HFC-134a (R-134a) service couplers to an CFC-12 (R-12) A/C system. The HFC-134a (R-134a) couplers will not properly connect to the CFC-12 (R-12) system. However, if an improper connection is attempted, discharging and contamination may occur.

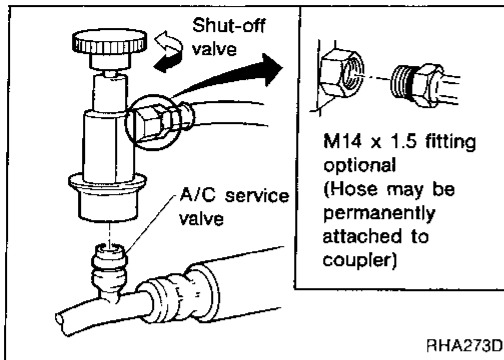

Shut off valve rotation	A/C service valve
Clockwise	Open
Counterclockwise	Close

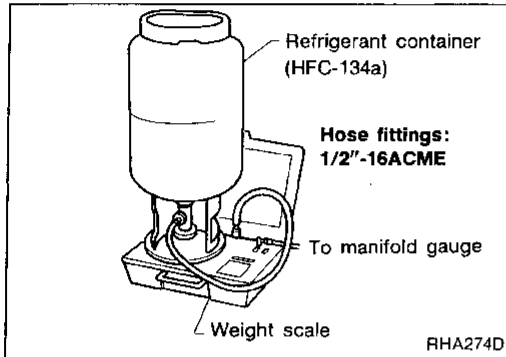

#### REFRIGERANT WEIGHT SCALE

Verify that no refrigerant other than HFC-134a (R-134a) and specified lubricants have been used with the scale. If the scale controls refrigerant flow electronically, the hose fitting must be 1/2"-16 ACME.

#### CHARGING CYLINDER

Using a charging cylinder is not recommended. Refrigerant may be vented into air from cylinder's top valve when filling the cylinder with refrigerant. Also, the accuracy of the cylinder is generally less than that of an electronic scale or of quality recycle/recharge equipment.



# DESCRIPTION

## Refrigeration Cycle

### REFRIGERANT FLOW

The refrigerant flow is in the standard pattern. Refrigerant flows through the compressor, condenser, liquid tank, evaporator, and back to the compressor.

The refrigerant evaporation through the evaporator coil is controlled by an externally equalized expansion valve, located inside the evaporator case.

### FREEZE PROTECTION

Under normal operating conditions, when the AUTO is switched on, the compressor runs continuously, and the evaporator pressure, and therefore temperature, is controlled by the V-6 variable displacement compressor to prevent freeze up.

### REFRIGERANT SYSTEM PROTECTION

#### Triple-pressure switch

The triple pressure switch is located on the liquid tank. If the system pressure rises or falls out of specifications, the switch opens to interrupt compressor clutch operation. Triple-pressure switch closes to turn on the cooling fan to reduce system pressure.

#### Pressure relief valve

The refrigerant system is protected by a pressure relief valve. The valve is located on the bottom of the compressor. When refrigerant system pressure increases abnormally [over 3,727 kPa (38 kg/cm<sup>2</sup>, 540 psi)], the relief valve's port opens. The valve then releases refrigerant into the atmosphere.

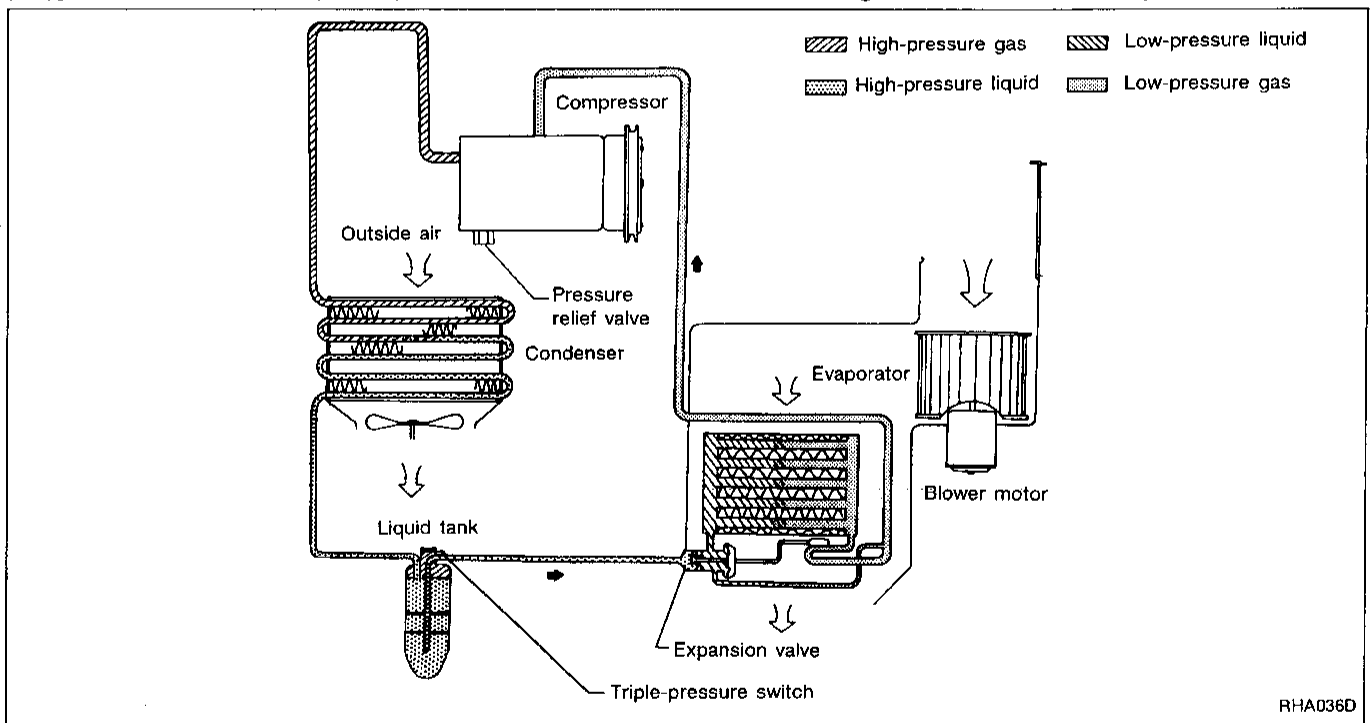

### V-6 Variable Displacement Compressor

#### GENERAL INFORMATION

1. The V-6 variable compressor differs from previous units. The vent temperatures of the V-6 variable compress do not drop too far below 5°C (41°F) when:
  - evaporator intake air temperature is less than 20°C (68°F)
  - engine is running at speeds less than 1,500 rpm.This is because the V-6 compressor provides a means of "capacity" control.
2. The V-6 variable compressor provides refrigerant control under varying conditions. During cold winters, it may not produce high refrigerant pressure discharge (compared to previous units) when used with air conditioning systems.
3. A "clanking" sound may occasionally be heard during refrigerant charge. The sound indicates that the tilt angle of the swash plate has changed and is not a problem.
4. For air conditioning systems with the V-6 compressor, the clutch remains engaged unless: the system main switch, fan switch or ignition switch is turned OFF. When ambient (outside) temperatures are low or when the amount of refrigerant is insufficient, the clutch is disengaged to protect the compressor.
5. A constant range of suction pressure is maintained when engine speed is greater than a certain value. It normally ranges from 147 to 177 kPa (1.5 to 1.8 kg/cm<sup>2</sup>, 21 to 26 psi) under varying conditions.  
In previous compressors, however, suction pressure was reduced with increases in engine speed.

# DESCRIPTION

## V-6 Variable Displacement Compressor (Cont'd)

### DESCRIPTION

#### General

The variable compressor is basically a swash plate type that changes piston stroke in response to the required cooling capacity.

The tilt of the swash plate allows the piston's stroke to change so that refrigerant discharge can be continuously changed from 10.5 to 184 cm<sup>3</sup> (0.641 to 11.228 cu in).

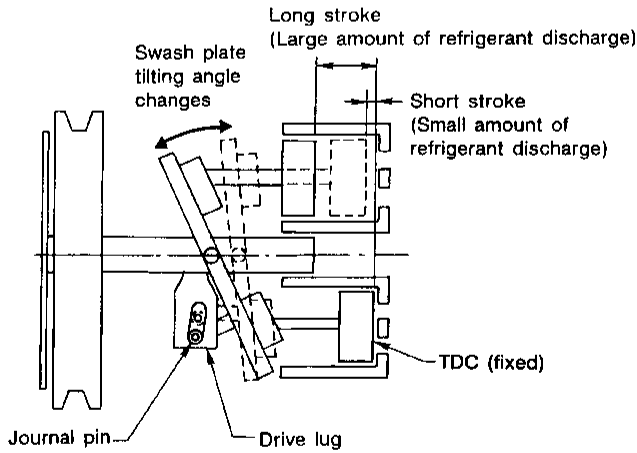
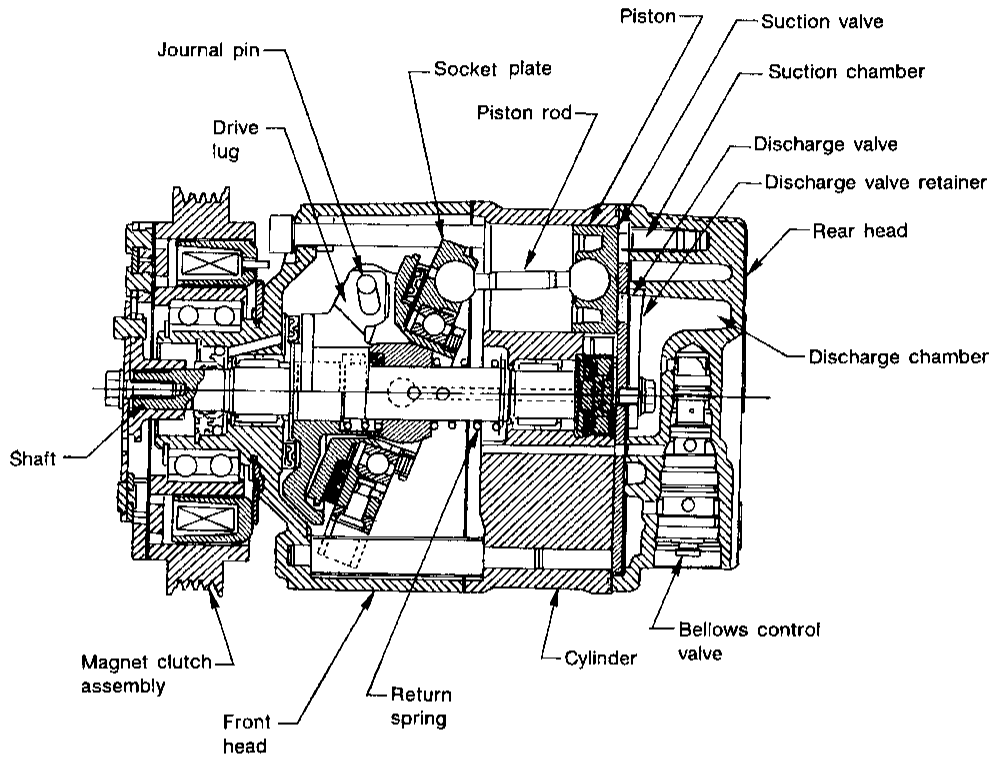

Discharge control	Discharge capacity cm <sup>3</sup> (cu in)/rev.	Piston stroke length mm (in)
Minimum	10.5 (0.641)	1.6 (0.063)
Maximum	184 (11.228)	28.6 (1.126)

RHA037DA

GI  
MA  
EM  
LC  
EC  
FE  
AT  
PD  
FA  
RA  
BR  
ST  
RS  
BT  
HA  
EL  
IDX

## DESCRIPTION

### V-6 Variable Displacement Compressor (Cont'd)

#### Operation

##### 1. Operation control valve

Operation control valve is located in the suction port (low-pressure) side, and opens or closes in response to changes in refrigerant suction pressure.

Operation of the valve controls the internal pressure of the crankcase.

The angle of the swash plate is controlled between the crankcase's internal pressure and the piston cylinder pressure.

##### 2. Maximum cooling

Refrigerant pressure on the low-pressure side increases with an increase in heat loads.

When this occurs, the control valve's bellows compress to open the low-pressure side valve and close the high-pressure side valve.

This causes the following pressure changes:

- the crankcase's internal pressure to equal the pressure on the low-pressure side;
- the cylinder's internal pressure to be greater than the crankcase's internal pressure.

Under this condition, the swash plate is set to the maximum stroke position.

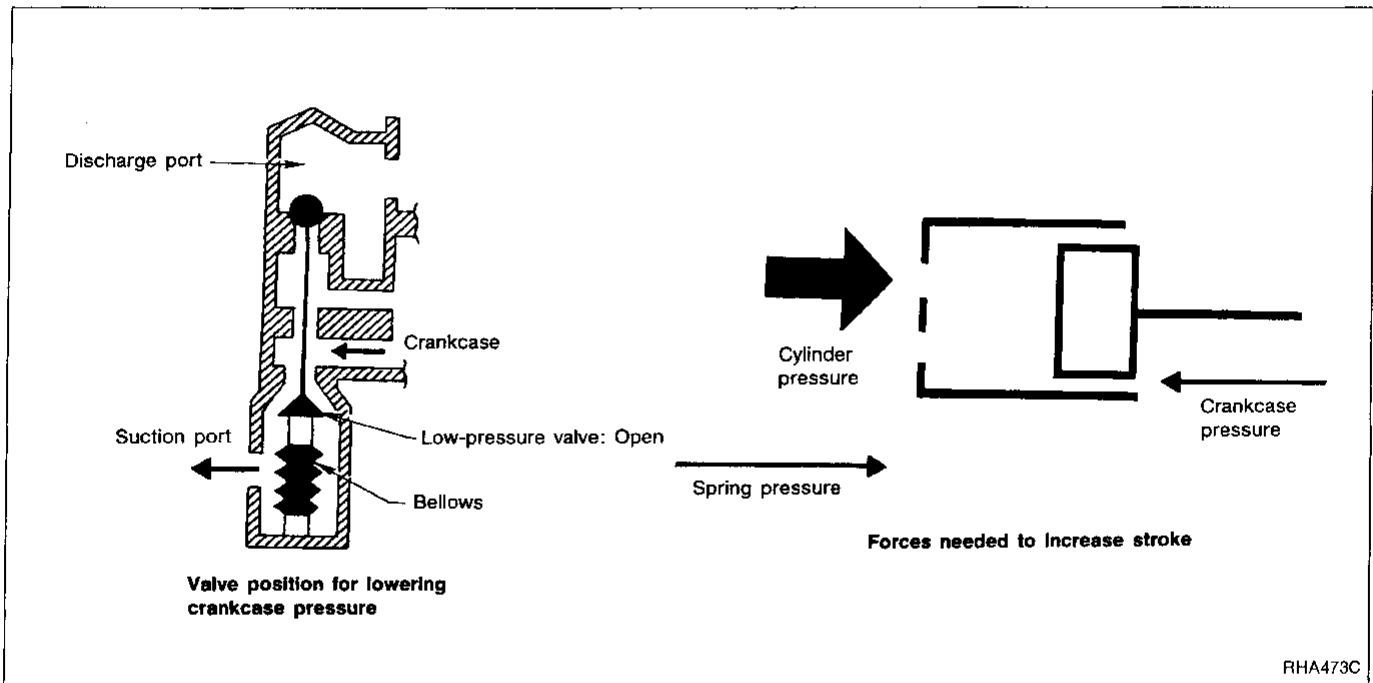

# DESCRIPTION

## V-6 Variable Displacement Compressor (Cont'd)

### 3. Capacity control

- Refrigerant pressure on suction side is low during high speed driving or when ambient or interior temperature is low.
- The bellows expands when refrigerant pressure on the suction pressure side drops below approximately 177 kPa (1.8 kg/cm<sup>2</sup>, 26 psi).

Since suction pressure is low, it makes the suction port close and the discharge port open. Thus, crankcase pressure becomes high as high pressure enters the crankcase.

- The force acts around the journal pin near the swash plate, and is generated by the pressure difference before and behind the piston.

The drive lug and journal pin are located where the piston generates the highest pressure. Piston pressure is between suction pressure  $P_s$  and discharge pressure  $P_d$ , which is near suction pressure  $P_s$ . If crankcase pressure  $P_c$  rises due to capacity control, the force around the journal pin makes the swash plate angle decrease and also the piston stroke decrease. In other words, crankcase pressure increase triggers pressure difference between the piston and the crankcase. The pressure difference changes the angle of the swash plate.

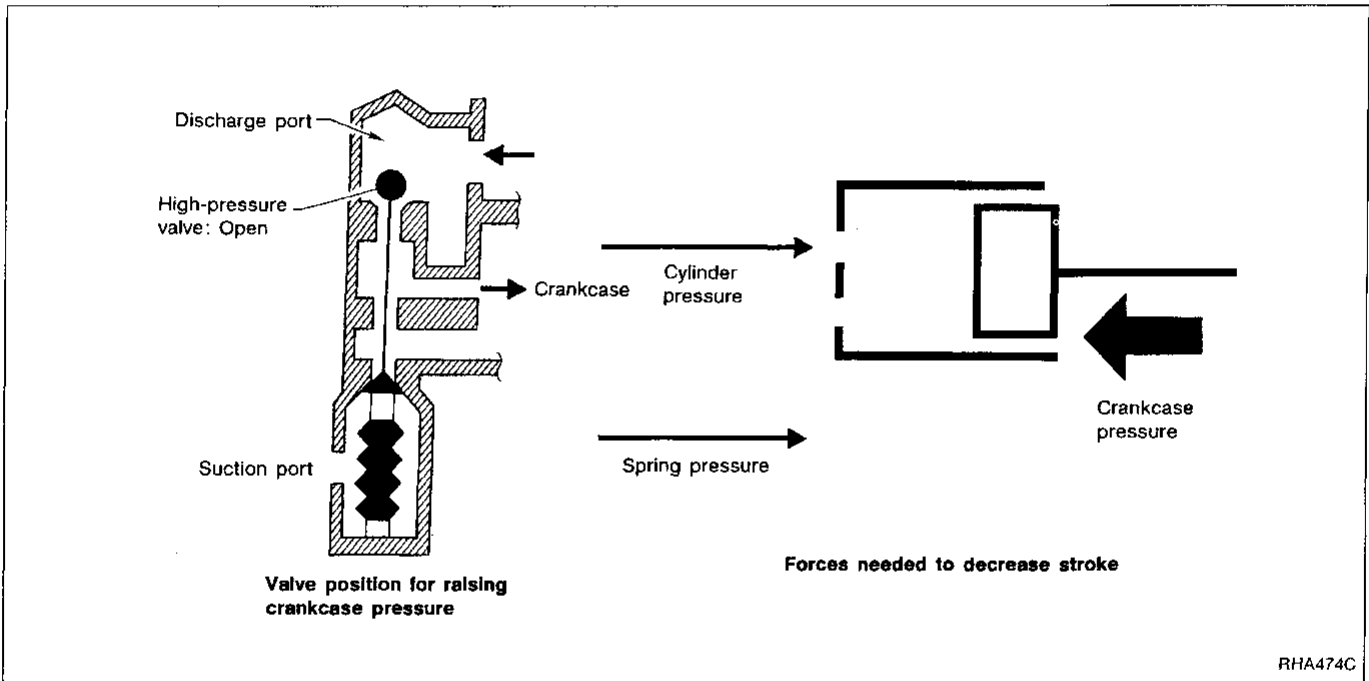

# DESCRIPTION

## Component Layout

SEC. 270-271-272-273

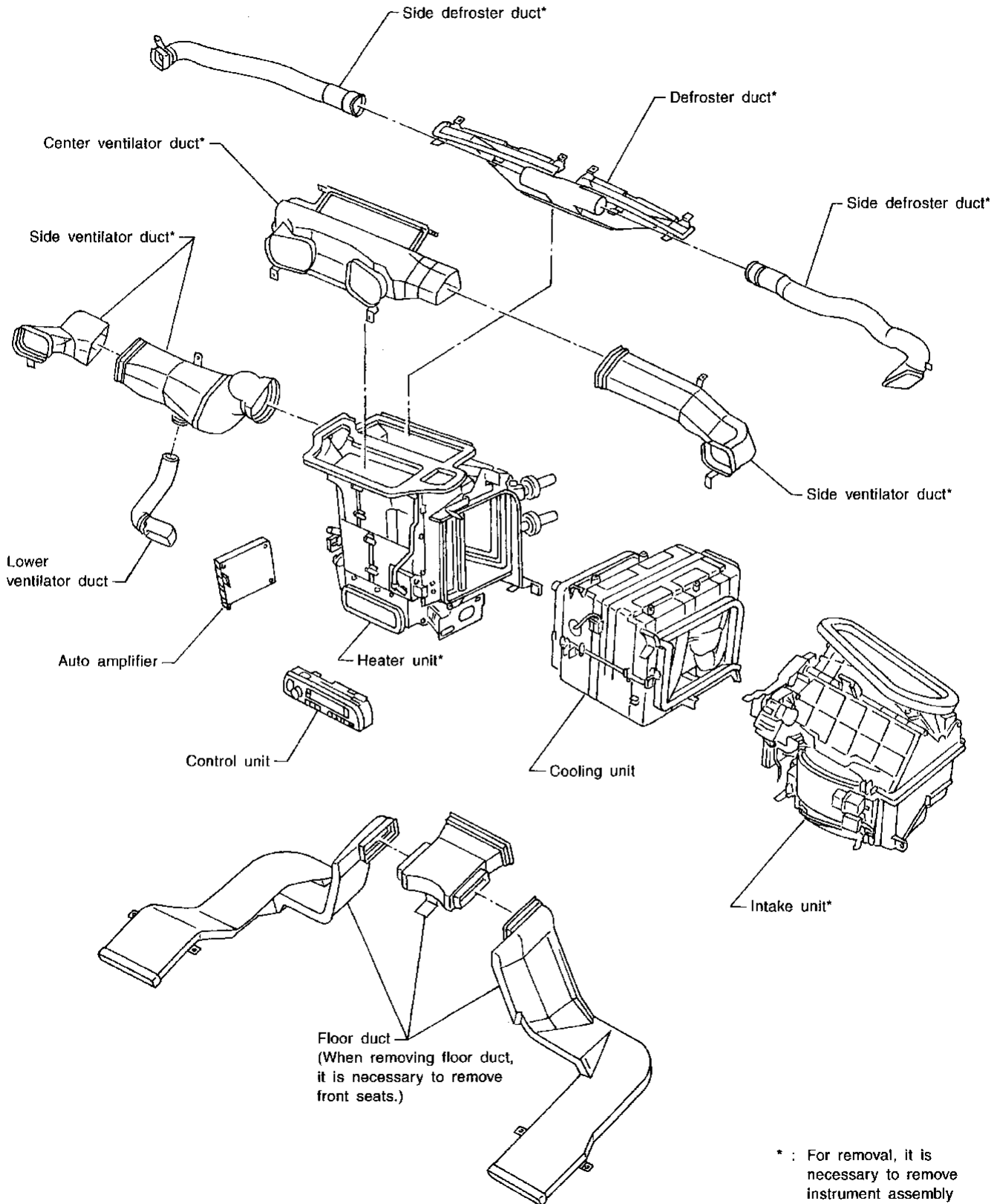





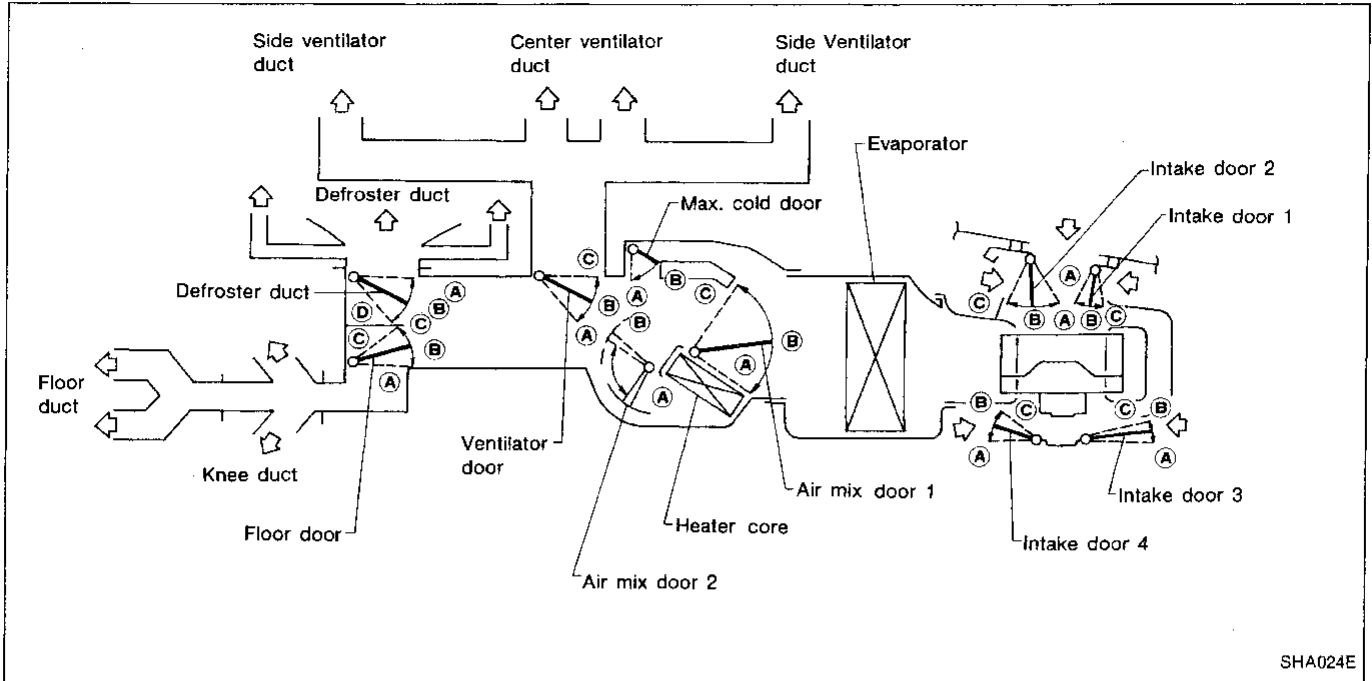

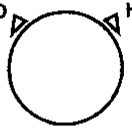

# DESCRIPTION

## Discharge Air Flow

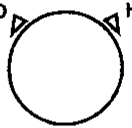

SHA024E

POSITION	MODE BUTTON				DEF BUTTON		AUTO BUTTON	ECON BUTTON	REC BUTTON		TEMPERATURE SWITCH				
	VENT	B/L	F/D1	F/D2	ON	OFF*1			ON	OFF	COLD  HOT				
															
DOOR					INDICATOR				INDICATOR		18°C (65°F)		32°C (85°F)		
					ON	OFF			ON	OFF					
VENT DOOR	(A)	(B)	(C)	(C)	(C)		AUTO	ECON							
FLOOR DOOR	(A)	(B)	(C)	(B)	(A)										
DEF DOOR	(A)	(A)	(B)	(C)	(D)										
AIR MIX DOOR 1													(A)		(C)
AIR MIX DOOR 2													(A)	AUTO	(B)
MAX. COLD DOOR		(A)											(A)		(B)
INTAKE DOOR 1						(C)					(A)				
INTAKE DOOR 2						(C)					(A)				
INTAKE DOOR 3						(C)			(A)	AUTO			(B)*2		
INTAKE DOOR 4						(C)			(A)				(B)*2		

\*1: When AUTO or ECON switch and MODE switch are pressed.

\*2: System in F/D1 or F/D2 mode with fan operating at high speeds.

## DESCRIPTION

---

### Introduction

The Automatic Temperature Control (ATC) system provides automatic regulation of the vehicles interior temperature. The operator selects "set temperature", on which the regulation is based, regardless of the outside temperature changes. This is done by utilizing a microcomputer, also referred to as the automatic amplifier, which receives input signals from several sensors. The automatic amplifier uses these input signals (including the set temperature) to automatically control the ATC system's outlet air volume, air temperature, and air distribution.

### Features

#### Air mix door control

The air mix door is automatically controlled so that in-vehicle temperature will reach, and be maintained at the operator selected "set temperature". For a given set temperature, the air mix door position will depend on: Ambient temperature, in-vehicle temperature, amount of sunload, and intake air temperature.

#### Fan speed control

Blower speed is automatically controlled based on temperature setting, ambient temperature, in-vehicle temperature, intake air temperature, amount of sunload and air mix door position.

With FAN switch set to "AUTO", the blower motor starts to gradually increase air flow volume.

When engine coolant temperature is low, the blower motor operation is delayed to prevent cool air from flowing.

#### Intake door control

The intake door position will be determined by: Ambient temperature, in-vehicle temperature, and whether the compressor is on or off.

#### Outlet door control

The outlet door position will be determined by: Ambient temperature, in-vehicle temperature, intake air temperature, and amount of sunload.

#### Compressor clutch control

The compressor operation (ON-OFF) will be determined by the ambient temperature and intake air temperature.

#### Recirculation switch

When RECIRC switch is pressed, intake door is fixed at RECIRC position.

#### Self-diagnostic system

The self-diagnostic system consists of five steps. Each step can be accessed by pushing the switches on the automatic amplifier.

STEP 1: Checks LEDs and segments of the display.

STEP 2: Checks each sensor circuit for open or short circuit.

STEP 3: Checks mode door position.

STEP 4: Checks operation of each actuator.

STEP 5: Checks temperature detected by each sensor.

AUXILIARY TRIMMER MECHANISM: Set temperature trimmer.

#### CONSULT operation

In addition to AUXILIARY TRIMMER MECHANISM in Self-diagnostic system, recent changes have made it possible to use CONSULT. This enables the following functions to be controlled by AUTOMATIC MODE.

STEP 1: Adjustment of highest blower fan speed  
(the adjustment of blower motor voltage)

STEP 2: Adjustment of highest blower fan speed changing point  
(the adjustment of the time required for cool-down)

STEP 3: Adjustment of outlet door changing point  
(the adjustment of the time required to change B/L to F/D)

#### Memory function

With ignition switch turned OFF, the auto amplifier stores in memory the set temperature and inputs of various switches. When the ignition switch is turned ON, the system begins operation with the information stored in memory. The system, then immediately compensates for the actual operating conditions.

#### Refrigeration cycle

Refer to page HA-9 for the description of the refrigeration cycle.



# DESCRIPTION

## Control Operation

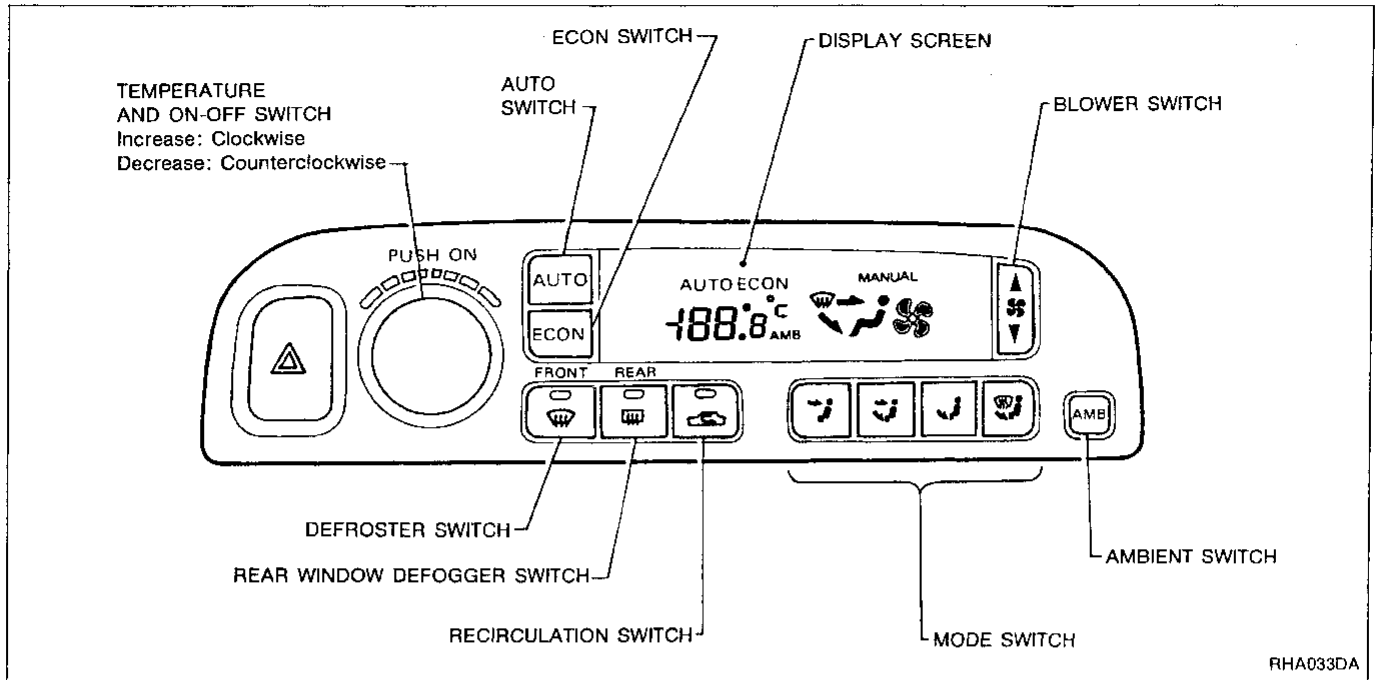

### DISPLAY SCREEN

Displays the operational status of the system.

### AUTO SWITCH

The compressor, air inlet door, air mix door, outlet doors, and blower speed are automatically controlled so that the in-vehicle temperature will reach, and be maintained at the set temperature selected by the operator.

### ECON SWITCH

Fully automatic control with the compressor off. With the compressor off, the system will not remove heat (cool) or de-humidify. The system will maintain the in-vehicle temperature at the set temperature when the set temperature is above the ambient (outside) temperature.





### TEMPERATURE INCREASE/DECREASE AND ON-OFF SWITCH

Increases or decreases the set temperature.

The compressor and blower are off, the air inlet door is set to the outside air position. Then, the air outlet doors are set to the foot (76% foot and 24% defrost) position. In the off position the ATC system uses the vehicle's "flow through" ventilation. It tries to maintain the interior temperature based on the last set temperature of the system.





### BLOWER SWITCH

Manual control of the blower speed. Four speeds are available for manual control (as shown on the display screen):

low  , medium low  , medium high  , high 

### MODE SWITCH

Manual control of the air discharge outlets. These selections are available (as shown on the display screen):

VENT  , B/L  , FOOT/DEF1  , FOOT/DEF2 

## DESCRIPTION

---

### Control Operation (Cont'd)

#### AMBIENT SWITCH

Shows the ambient (outside) air temperature on the display screen for 5 seconds.

#### RECIRCULATION (REC) SWITCH

Positions the air inlet door to the recirculation position.

#### DEFROSTER (DEF) SWITCH

Positions the air discharge doors to the defrost position. Also positions the air inlet door to the outside air position. The compressor operates at ambient temperature approx. 12°C (54°F) or above.

#### REAR WINDOW DEFOGGER SWITCH

Activates and deactivates the rear window defogger.

# TROUBLE DIAGNOSES

## Contents

<b>How to Perform Trouble Diagnoses for Quick and Accurate Repair</b> .....	HA- 22	
<b>Operational Check</b> .....	HA- 23	
<b>Symptom Chart</b> .....	HA- 26	GI
<b>Self-diagnosis</b> .....	HA- 30	
CONSULT AND ON-BOARD SELF-DIAGNOSTIC SYSTEM .....	HA- 30	
<b>Self-diagnosis — ON-BOARD</b> .....	HA- 31	MA
INTRODUCTION AND GENERAL DESCRIPTION .....	HA- 31	
STEP BY STEP PROCEDURE .....	HA- 32	EM
HOW TO INTERPRET THE RESULTS .....	HA- 35	
STEP 1: Checks LEDs and segments .....	HA- 35	
STEP 2: Checks each sensor circuit for open or short circuit .....	HA- 35	LC
STEP 3: Checks mode and intake door positions .....	HA- 36	
STEP 4: Checks operation of each actuator .....	HA- 37	
STEP 5: Checks temperature detected by sensors, and detects multiplex communication error .....	HA- 38	EC
AUXILIARY MECHANISM: Temperature setting trimmer .....	HA- 40	FE
<b>Self-diagnosis — CONSULT</b> .....	HA- 41	
CONSULT INSPECTION PROCEDURE .....	HA- 41	
WORK SUPPORT .....	HA- 42	AT
SEGMENT CHECK: Checks LEDs and segments .....	HA- 42	
MODE DOOR CHECK: Checks mode door position .....	HA- 42	
INTAKE DOOR CHECK: Checks intake door position .....	HA- 43	PD
TEMP. SETTING TRIMMER: Temperature setting trimmer .....	HA- 43	
MAX. OUTLET FLOW ADJUSTMENT: Adjustment of highest blower fan speed .....	HA- 44	
FAN SPEED CONTROL ADJUSTMENT: Adjustment of highest blower fan speed changing point .....	HA- 44	FA
MODE DOOR CONTROL ADJUSTMENT: Adjusting outlet door changing point .....	HA- 45	RA
SELF-DIAGNOSTIC RESULTS .....	HA- 46	
DATA MONITOR .....	HA- 47	
ACTIVE TEST .....	HA- 48	BR
<b>Preliminary Check</b> .....	HA- 49	
PRELIMINARY CHECK 1 (Air outlet does not change.) .....	HA- 49	ST
PRELIMINARY CHECK 2 (Intake door does not change.) .....	HA- 50	RS
PRELIMINARY CHECK 3 (Insufficient cooling) .....	HA- 51	
PRELIMINARY CHECK 4 (Insufficient heating) .....	HA- 53	BT
PRELIMINARY CHECK 5 (Blower motor operation is malfunctioning.) .....	HA- 54	HA
PRELIMINARY CHECK 6 (Magnet clutch does not engage.) .....	HA- 55	
PRELIMINARY CHECK 7 (Discharged air temperature does not change.) .....	HA- 56	EL
PRELIMINARY CHECK 8 (Noise) .....	HA- 57	DX
<b>Performance Test Diagnoses</b> .....	HA- 58	
INSUFFICIENT COOLING .....	HA- 58	
<b>Performance Chart</b> .....	HA- 60	
TEST CONDITION .....	HA- 60	
TEST READING .....	HA- 60	
<b>Trouble Diagnoses for Abnormal Pressure</b> .....	HA- 61	
<b>A/C Component Layout</b> .....	HA- 65	

# TROUBLE DIAGNOSES

## Contents (Cont'd)

<b>Circuit Diagram</b> .....	HA- 67
<b>Wiring Diagram — A/C —</b> .....	HA- 68
<b>Main Power Supply and Ground Circuit Check</b> .....	HA- 76
<b>Diagnostic Procedure 1</b>	
SYMPTOM: Self-diagnosis cannot be performed. ....	HA- 77
<b>Diagnostic Procedure 2</b>	
SYMPTOM: Ambient sensor circuit is open. (21 is indicated on auto amp. as a result of conducting Self-diagnosis STEP 2.) .....	HA- 78
<b>Diagnostic Procedure 3</b>	
SYMPTOM: In-vehicle sensor circuit is open. (22 is indicated on auto amp. as a result of conducting Self-diagnosis STEP 2.) .....	HA- 79
<b>Diagnostic Procedure 4</b>	
SYMPTOM: Thermal transmitter circuit is open. (23 is indicated on auto amp. as a result of conducting Self-diagnosis STEP 2.) .....	HA- 79
<b>Diagnostic Procedure 5</b>	
SYMPTOM: Intake sensor circuit is open. (24 is indicated on auto amp. as a result of conducting Self-diagnosis STEP 2.) .....	HA- 80
<b>Diagnostic Procedure 6</b>	
SYMPTOM: Sunload sensor circuit is open. (25 is indicated on auto amp. as a result of conducting Self-diagnosis STEP 2.) .....	HA- 81
<b>Diagnostic Procedure 7</b>	
SYMPTOM: PBR circuit is open. (26 is indicated on auto amp. as a result of conducting Self-diagnosis STEP 2.) .....	HA- 82
<b>Diagnostic Procedure 8</b>	
SYMPTOM: Ambient sensor circuit is shorted. (-21 is indicated on auto amp. as a result of conducting Self-diagnosis STEP 2.) .....	HA- 83
<b>Diagnostic Procedure 9</b>	
SYMPTOM: In-vehicle sensor circuit is shorted. (-22 is indicated on auto amp. as a result of conducting Self-diagnosis STEP 2.) .....	HA- 84
<b>Diagnostic Procedure 10</b>	
SYMPTOM: Thermal transmitter circuit is shorted. (-23 is indicated on auto amp. as a result of conducting Self-diagnosis STEP 2.) .....	HA- 85
<b>Diagnostic Procedure 11</b>	
SYMPTOM: Intake sensor circuit is shorted. (-24 is indicated on auto amp. as a result of conducting Self-diagnosis STEP 2.) .....	HA- 85
<b>Diagnostic Procedure 12</b>	
SYMPTOM: Sunload sensor circuit is shorted. (-25 is indicated on auto amp. as a result of conducting Self-diagnosis STEP 2.) .....	HA- 86
<b>Diagnostic Procedure 13</b>	
SYMPTOM: PBR circuit is shorted. (-26 is indicated on auto amp. as a result of conducting Self-diagnosis STEP 2.) .....	HA- 87
<b>Diagnostic Procedure 14</b>	
SYMPTOM: Mode door motor does not operate normally. ....	HA- 88
<b>Diagnostic Procedure 15</b>	
SYMPTOM: Intake door motor does not operate normally. ....	HA- 91
<b>Diagnostic Procedure 16</b>	
SYMPTOM: Air mix door motor does not operate normally. ....	HA- 93
<b>Diagnostic Procedure 17</b>	
SYMPTOM: Blower motor operation is malfunctioning under out of Starting Fan Speed Control. ....	HA- 94

# TROUBLE DIAGNOSES

## Contents (Cont'd)

### Diagnostic Procedure 18

SYMPTOM: Magnet clutch does not engage after performing

Preliminary Check 6. .... HA- 97

### Diagnostic Procedure 19

SYMPTOM: Max. cold door motor does not operate normally. .... HA-100 **GI**

Electrical Components Inspection ..... HA-101

Control Linkage Adjustment ..... HA-102 **VA**

**EM**

**LC**

**EC**

**FE**

**AT**

**PD**

**FA**

**RA**

**BR**

**ST**

**RS**

**BT**

**HA**

**EL**

**IDX**

## How to Perform Trouble Diagnoses for Quick and Accurate Repair

### WORK FLOW

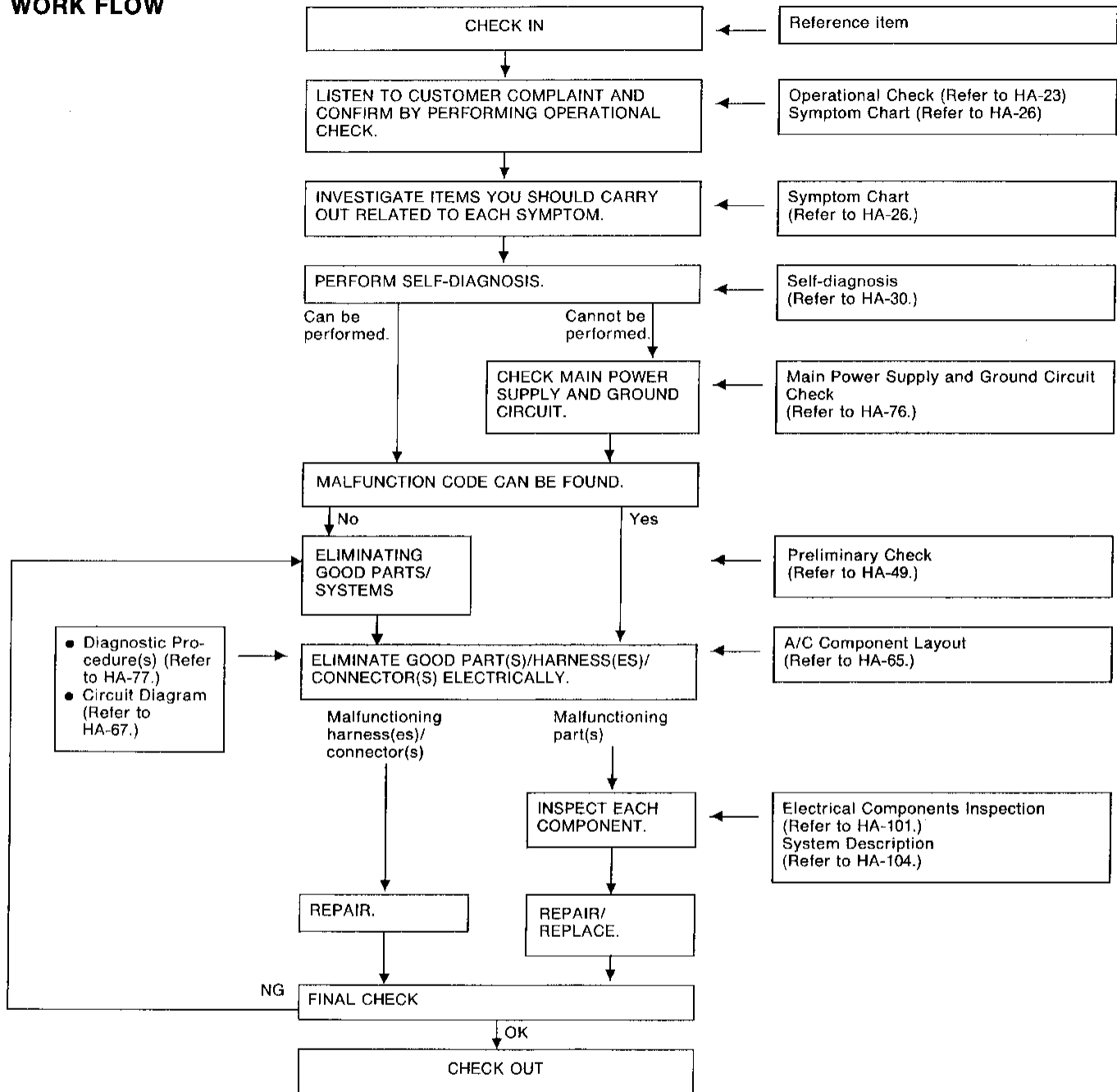

## Operational Check

The purpose of the operational check is to confirm that the system operates as it should. The systems which will be checked are the blower, mode (discharge air), ambient display, intake air, defrost, econ, auto, temperature decrease, temperature increase, memory function and rear window defogger.

### CONDITIONS:

Engine running at normal operating temperature.

### PROCEDURE:

#### 1. Check blower

- 1) Press BLOWER switch (▲: Up) one time. MANUAL should appear on the display. Blower should operate on low speed, and the fan symbol should have one blade lit ( ).
- 2) Press BLOWER switch one more time.
- 3) Continue checking blower speed and fan symbol until all four speeds have been checked.
- 4) Leave blower on high speed.
- 5) Press BLOWER switch (▼: Down) one time. Blower should operate in third speed.
- 6) Continue checking blower speed and fan symbol until all three speeds have been checked.

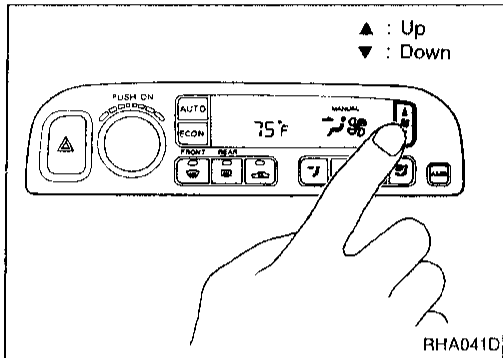

#### 2. Check discharge air

- 1) Press the switch. Display should show air to the face.
- 2) Confirm that all discharge air comes out the face vents.
- 3) Press the switch. Display should show air to face and foot (bi-level).
- 4) Confirm that discharge air comes out the face and foot vents.
- 5) Press the switch. Display should show air to foot.
- 6) Confirm that discharge air comes mostly from the foot outlets, with some air from the defroster outlets.
- 7) Press the switch. Display should show air to foot and defrost.
- 8) Confirm that discharge air comes mostly from the defrost vents, with some air from the foot outlets.

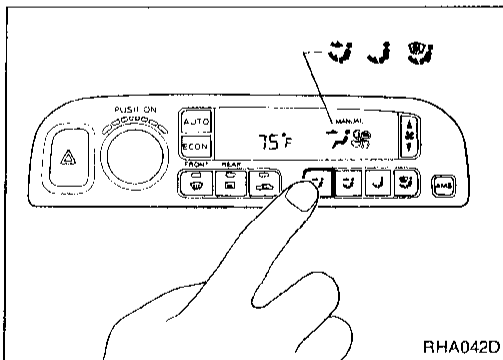

## TROUBLE DIAGNOSES

### Operational Check (Cont'd)

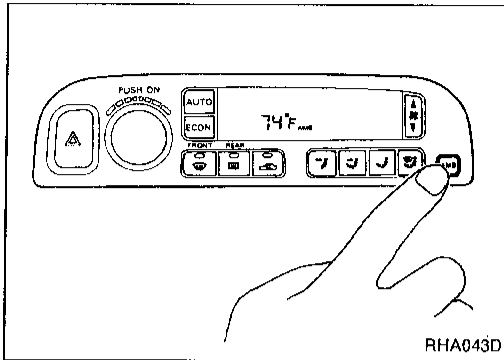

#### 3. Check ambient display

Press the AMB switch.

Display should show the outside (ambient) temperature for approximately 5 seconds.

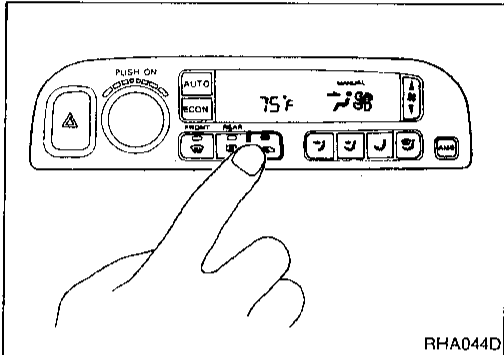

#### 4. Check recirculation

- 1) Press RECIRCULATION switch.  
Recirculation indicator should light.
- 2) Listen for intake door position change (you should hear blower sound change slightly).

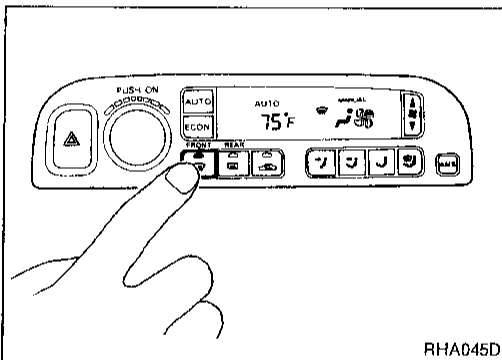

#### 5. Check defrost

- 1) Press DEFROSTER switch.
- 2) Check that recirculation is canceled.  
The discharge air should be coming only from the defrost vents.
- 3) Confirm that the compressor clutch is engaged (visual inspection).  
The display should indicate AUTO, MANUAL, and defrost (☀).

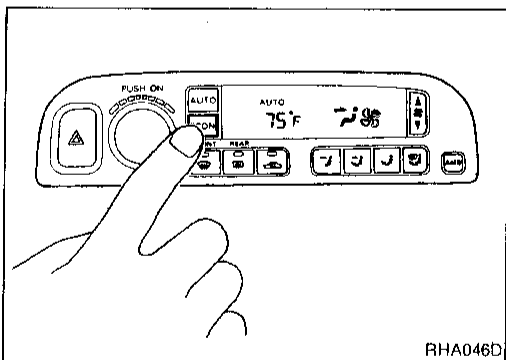

#### 6. Check ECON mode

- 1) Press ECON switch.  
Defrost should be canceled.  
Discharge air outlet will depend on ambient, in-vehicle, and set temperatures.  
Display should indicate ECON (no AUTO, no MANUAL).
- 2) Confirm that the compressor clutch is not engaged (visual inspection).

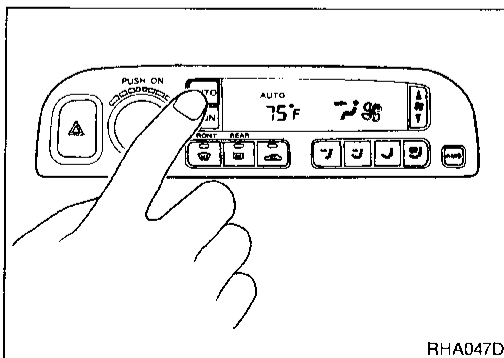

#### 7. Check AUTO mode

- 1) Press AUTO switch.
- 2) Confirm that the compressor clutch engages (audio or visual inspection).  
Display should indicate AUTO (no ECON, no MANUAL).  
(Discharge air will depend on ambient, in-vehicle, and set temperatures).



# TROUBLE DIAGNOSES

## Operational Check (Cont'd)

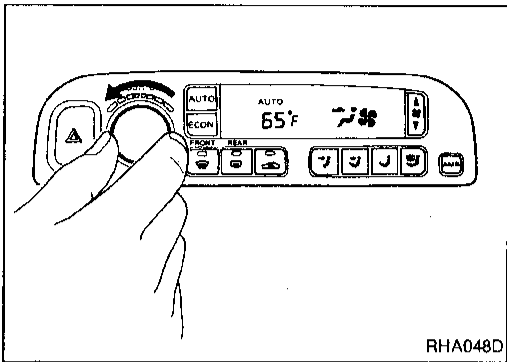

### 8. Check temperature decrease

- 1) Turn temperature switch counterclockwise until 18°C (65°F) is displayed.
- 2) Check for cold air at discharge air outlets.

GI

MA

EM

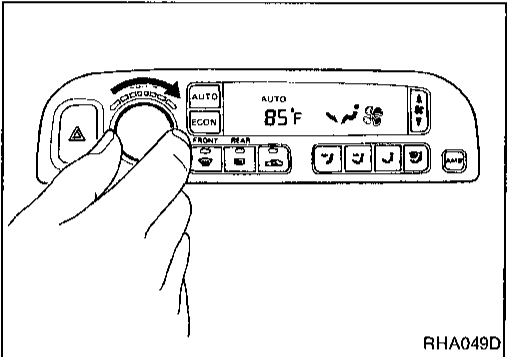

### 9. Check temperature increase

- 1) Turn temperature switch clockwise until 32°C (85°F) is displayed.
- 2) Listen for changes in blower speed as set temperature changes.
- 3) Check for hot air at discharge air outlets.

LC

EC

FE

AT

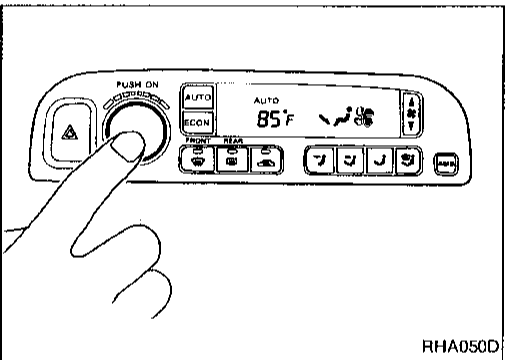

### 10. Check memory function

- 1) Press ON-OFF switch.
- 2) Turn the ignition off.
- 3) Turn the ignition on.
- 4) Press the AUTO switch.
- 5) Confirm that the set temperature remained at 32°C (85°F).

PD

FA

RA

BR

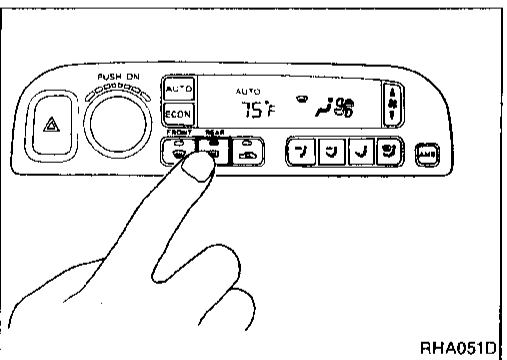

### 11. Check rear window defogger

- 1) Press rear window defogger switch.  
Rear window defogger indicator should turn on.

ST

RS

BT

HA

EL

IDX

# TROUBLE DIAGNOSES

## Symptom Chart

### DIAGNOSTIC TABLE

PROCEDURE		Self-diagnosis					CONSULT				Preliminary Check										
		STEP 1 (HA-35)	STEP 2 (HA-35)	STEP 3 (HA-36)	STEP 4 (HA-37)	STEP 5 (HA-38)	AUXILIARY MECHANISM (HA-40)	WORK SUPPORT — SEGMENT CHECK (HA-42)	WORK SUPPORT — MODE DOOR CHECK (HA-42)	WORK SUPPORT — INTAKE DOOR CHECK (HA-43)	WORK SUPPORT — TEMP SETTING TRIMMER (HA-43)	SELF-DIAGNOSIS RESULTS (HA-46)	ACTIVE TEST (HA-48)	Preliminary Check 1 (HA-49)	Preliminary Check 2 (HA-50)	Preliminary Check 3 (HA-51)	Preliminary Check 4 (HA-53)	Preliminary Check 5 (HA-54)	Preliminary Check 6 (HA-55)	Preliminary Check 7 (HA-56)	Preliminary Check 8 (HA-57)
<b>SYMPTOM</b>																					
Air outlet does not change.		①	②	③	○	○	○	①	③	○	○	○	④	○	○	○	○	○	○	○	○
Intake door does not change.		①	②	③	○	○	○	○	③	○	○	○	○	④	○	○	○	○	○	○	○
Insufficient cooling		○	○	○	○	○	○	○	○	○	○	○	○	○	○	○	①	○	○	○	○
Insufficient heating		○	○	○	○	○	○	○	○	○	○	○	○	○	○	○	○	①	○	○	○
Blower motor operation is malfunctioning.		①	②	○	○	○	○	①	○	○	○	○	○	○	○	○	○	○	③	○	○
Magnet clutch does not engage.		①	②	○	○	○	○	①	○	○	○	○	○	○	○	○	○	○	○	③	○
Discharge air temperature does not change.		①	②	○	○	○	○	①	○	○	○	○	○	○	○	○	○	○	○	○	③
Noise		○	○	○	○	○	○	○	○	○	○	○	○	○	○	○	○	○	○	○	①
Result of SELF-DIAGNOSIS RESULTS made with CONSULT or Self-diagnosis STEP 2	21	Ambient sensor circuit is open.		①	②	○	○	①	○	○	○	○	○	○	○	○	○	○	○	○	○
	22	In-vehicle sensor circuit is open.		①	②	○	○	①	○	○	○	○	○	○	○	○	○	○	○	○	○
	23	Thermal transmitter circuit is open.		①	②	○	○	①	○	○	○	○	○	○	○	○	○	○	○	○	○
	24	Intake sensor circuit is open.		①	②	○	○	①	○	○	○	○	○	○	○	○	○	○	○	○	○
	25	Sunload sensor circuit is open.		①	②	○	○	①	○	○	○	○	○	○	○	○	○	○	○	○	○
	26	PBR circuit is open.		①	②	○	○	①	○	○	○	○	○	○	○	○	○	○	○	○	○

①, ②: The number means checking order.

○: As for checking order, refer to each flow chart. (It depends on malfunctioning portion.)

# TROUBLE DIAGNOSES

## Symptom Chart (Cont'd)

Diagnostic Procedure										Main Power Supply and Ground Circuit Check														
Diagnostic Procedure 1 (HA-77)	Diagnostic Procedure 2 (HA-78)	Diagnostic Procedure 3 (HA-79)	Diagnostic Procedure 4 (HA-79)	Diagnostic Procedure 5 (HA-80)	Diagnostic Procedure 6 (HA-81)	Diagnostic Procedure 7 (HA-82)	Diagnostic Procedure 8 (HA-83)	Diagnostic Procedure 9 (HA-84)	Diagnostic Procedure 10 (HA-85)	Diagnostic Procedure 11 (HA-85)	Diagnostic Procedure 12 (HA-86)	Diagnostic Procedure 13 (HA-87)	Diagnostic Procedure 14 (HA-88)	Diagnostic Procedure 15 (HA-91)	Diagnostic Procedure 16 (HA-93)	Diagnostic Procedure 17 (HA-94)	Diagnostic Procedure 18 (HA-97)	Diagnostic Procedure 19 (HA-100)	Auto amp. (HA-76)	Control unit (HA-76)	7.5A Fuse #13 (HA-76)	7.5A Fuse #7 (HA-76)	15A Fuses #10 and #11 (HA-76)	7.5A Fuse #22 (HA-76)
	○	○		○	○	○	○	○		○	○	○	○	○	○	○	○	○	○	○	○	○	○	○
③		○		○	○	○	○	○	○	○	○	○	○	○	○	○	○	○	○	○	○	○	○	○
	⑤		○	○	○	○	○	○	○	○	○	○	○	○	○	○	○	○	○	○	○	○	○	○
		③		○	○	○	○	○	○	○	○	○	○	○	○	○	○	○	○	○	○	○	○	○
			③		○	○	○	○	○	○	○	○	○	○	○	○	○	○	○	○	○	○	○	○
				③		○	○	○	○	○	○	○	○	○	○	○	○	○	○	○	○	○	○	○
					③		○	○	○	○	○	○	○	○	○	○	○	○	○	○	○	○	○	○
						③		○	○	○	○	○	○	○	○	○	○	○	○	○	○	○	○	○

GI  
MA  
EM  
LC  
EC  
FE  
AT  
PD  
FA  
RA  
BR  
ST  
RS  
BT  
**HA**  
EL  
IDX

# TROUBLE DIAGNOSES

## Symptom Chart (Cont'd)

PROCEDURE		Self-diagnosis					CONSULT				Preliminary Check											
SYMPTOM		STEP 1 (HA-35)	STEP 2 (HA-35)	STEP 3 (HA-36)	STEP 4 (HA-37)	STEP 5 (HA-38)	AUXILIARY MECHANISM (HA-40)	WORK SUPPORT -- SEGMENT CHECK (HA-42)	WORK SUPPORT -- MODE DOOR CHECK (HA-42)	WORK SUPPORT -- INTAKE DOOR CHECK (HA-43)	WORK SUPPORT -- TEMP SETTING TRIMMER (HA-43)	SELF-DIAGNOSIS RESULTS (HA-46)	ACTIVE TEST (HA-48)	Preliminary Check 1 (HA-49)	Preliminary Check 2 (HA-50)	Preliminary Check 3 (HA-51)	Preliminary Check 4 (HA-53)	Preliminary Check 5 (HA-54)	Preliminary Check 6 (HA-55)	Preliminary Check 7 (HA-56)	Preliminary Check 8 (HA-57)	
Result of SELF-DIAGNOSIS RESULTS mode with CONSULT or Self-diagnosis STEP 2	-21	Ambient sensor circuit is shorted.		①	②	○	○	①			②											
	-22	In-vehicle sensor circuit is shorted.		①	②	○	○	①			②											
	-23	Thermal transmitter circuit is shorted.		①	②			①				②										
	-24	Intake sensor circuit is shorted.		①	②		○	①				②										
	-25	Sunload sensor circuit is shorted.		①	②			①				②										
	-26	PBR circuit is shorted.		①	②			①				②										
Self-diagnosis cannot be performed.																						
Mode door motor does not operate normally.		①	②	③	④	○		①	③		②	④										
Intake door motor does not operate normally.		①	②	③	④			①	③		②	④										
Air mix door motor does not operate normally.		①	②		④			①			②	③										
Blower motor operation is malfunctioning under out of Starting Fan Speed Control.		①	②		○	○		①			②	○						③				
Magnet clutch does not operate after performing Preliminary Check 6.		①	②		○	○		①			②	○							③			
Max. cold door motor does not operate normally.																						

①, ②: The number means checking order.

○: As for checking order, refer to each flow chart. (It depends on malfunctioning portion.)

# TROUBLE DIAGNOSES

## Symptom Chart (Cont'd)

Diagnostic Procedure										Main Power Supply and Ground Circuit Check			
Diagnostic Procedure 1 (HA-77)													
Diagnostic Procedure 2 (HA-78)													
Diagnostic Procedure 3 (HA-79)													
Diagnostic Procedure 4 (HA-79)													
Diagnostic Procedure 5 (HA-80)													
Diagnostic Procedure 6 (HA-81)													
Diagnostic Procedure 7 (HA-82)													
Diagnostic Procedure 8 (HA-83)						3							
Diagnostic Procedure 9 (HA-84)							3						
Diagnostic Procedure 10 (HA-85)								3					
Diagnostic Procedure 11 (HA-85)									3				
Diagnostic Procedure 12 (HA-86)													
Diagnostic Procedure 13 (HA-87)													
Diagnostic Procedure 14 (HA-88)													
Diagnostic Procedure 15 (HA-91)													
Diagnostic Procedure 16 (HA-93)													
Diagnostic Procedure 17 (HA-94)													
Diagnostic Procedure 18 (HA-97)													
Diagnostic Procedure 19 (HA-100)													
Auto amp. (HA-76)													
Control unit (HA-76)													
7.5A Fuse #13 (HA-76)													
7.5A Fuse #7 (HA-76)													
15A Fuses #10 and #11 (HA-76)													
7.5A Fuse #22 (HA-76)													

GI  
 MA  
 EM  
 LC  
 EC  
 FE  
 AT  
 PD  
 FA  
 RA  
 BR  
 ST  
 RS  
 BT  
**HA**  
 EL  
 IDX

# TROUBLE DIAGNOSES

## Self-diagnosis

### CONSULT AND ON-BOARD SELF-DIAGNOSTIC SYSTEM

Functions of CONSULT and the ON-BOARD SELF-DIAGNOSTIC SYSTEM are as follows:

ITEM	MONITOR				CHANGING PARAMETER	
	CONSULT	ON-BOARD		CON-SULT	ON-BOARD	
LEDs and segments	WORK SUPPORT	<input type="radio"/>	STEP 1	<input type="radio"/>		
Mode door motor position switch		<input type="radio"/>	STEP 3	<input type="radio"/>		
Intake door motor position switch		<input type="radio"/>		<input type="radio"/>		
Temperature setting trimmer		<input type="radio"/>	Temp. setting trimmer	<input type="radio"/>	<input type="radio"/>	<input type="radio"/>
Intake memory adjustment*1		X				
Max. outlet flow adjustment		<input type="radio"/>			<input type="radio"/>	
Fan speed control adjustment		<input type="radio"/>			<input type="radio"/>	
Mode door control adjustment		<input type="radio"/>			<input type="radio"/>	
Ambient sensor	SELF-DIAGNOSIS RESULTS	DATA MONITOR	STEP 5	<input type="radio"/>		
In-vehicle sensor				<input type="radio"/>		
Intake sensor			STEP 2	<input type="radio"/>		
Engine coolant temperature sensor (Thermal transmitter)				<input type="radio"/>		
Sunload sensor				<input type="radio"/>		
PBR				<input type="radio"/>		
Control switches				<input type="radio"/>		
Mode door position	ACTIVE TEST	DATA MONITOR	STEP 4	<input type="radio"/>		
Intake door position				<input type="radio"/>		
Air mix door angle				<input type="radio"/>		
Blower motor voltage				<input type="radio"/>		
Compressor operation				<input type="radio"/>		
Trimmed temperature				<input type="radio"/>		
Intake door position memory*1		X				
Highest blower fan speed		<input type="radio"/>				
Highest blower fan speed changing point		<input type="radio"/>				
Outlet door changing point		<input type="radio"/>				

\*1: Items shown on CONSULT's display but cannot be activated.

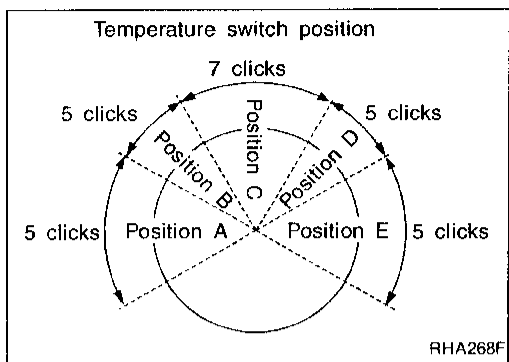

## Self-diagnosis — ON-BOARD

### INTRODUCTION AND GENERAL DESCRIPTION

The self-diagnostic system diagnoses sensors, door motors, blower motor and multiplex communication errors, etc. by system line. Refer to applicable sections (items) for details. Shifting from normal control to the self-diagnostic system is done as follows. Start the engine (turn the ignition switch from "OFF" to "ON") and press switch for at least 5 seconds. The switch must be pressed within 10 seconds after starting the engine (ignition switch is turned "ON"). This system will be canceled by either pressing **AUTO** switch or turning the ignition switch "OFF". Shifting from one step to another is accomplished by means of rotating temperature switch, as required. Additionally shifting from STEP 5 to AUXILIARY MECHANISM is accomplished by means of pushing BLOWER switch.

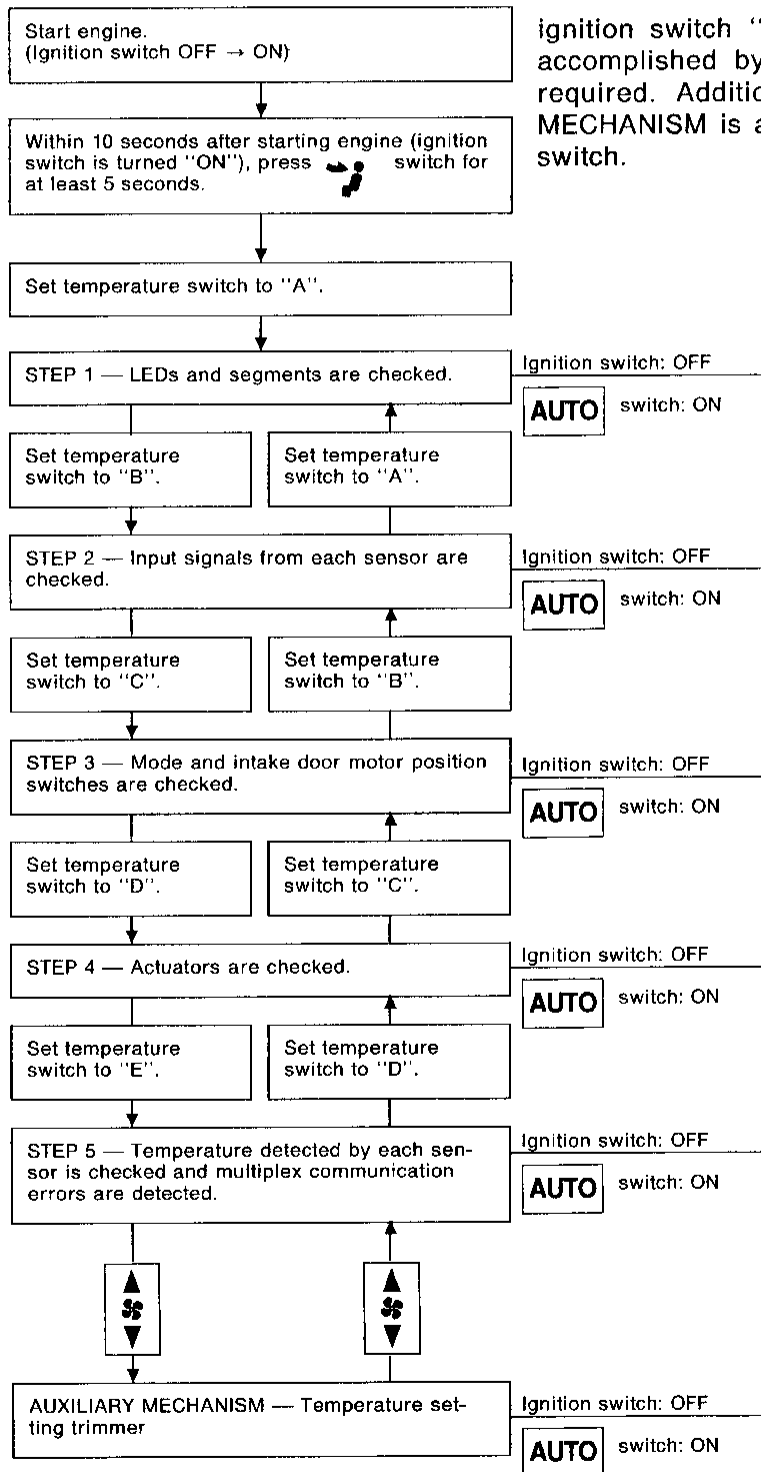

G1  
MA  
EM  
LC  
EC  
FE  
AT  
PD  
FA  
RA  
BR  
ST  
RS  
BT  
HA  
EL  
IDX

# TROUBLE DIAGNOSES

## Self-diagnosis — ON-BOARD (Cont'd)

### STEP BY STEP PROCEDURE

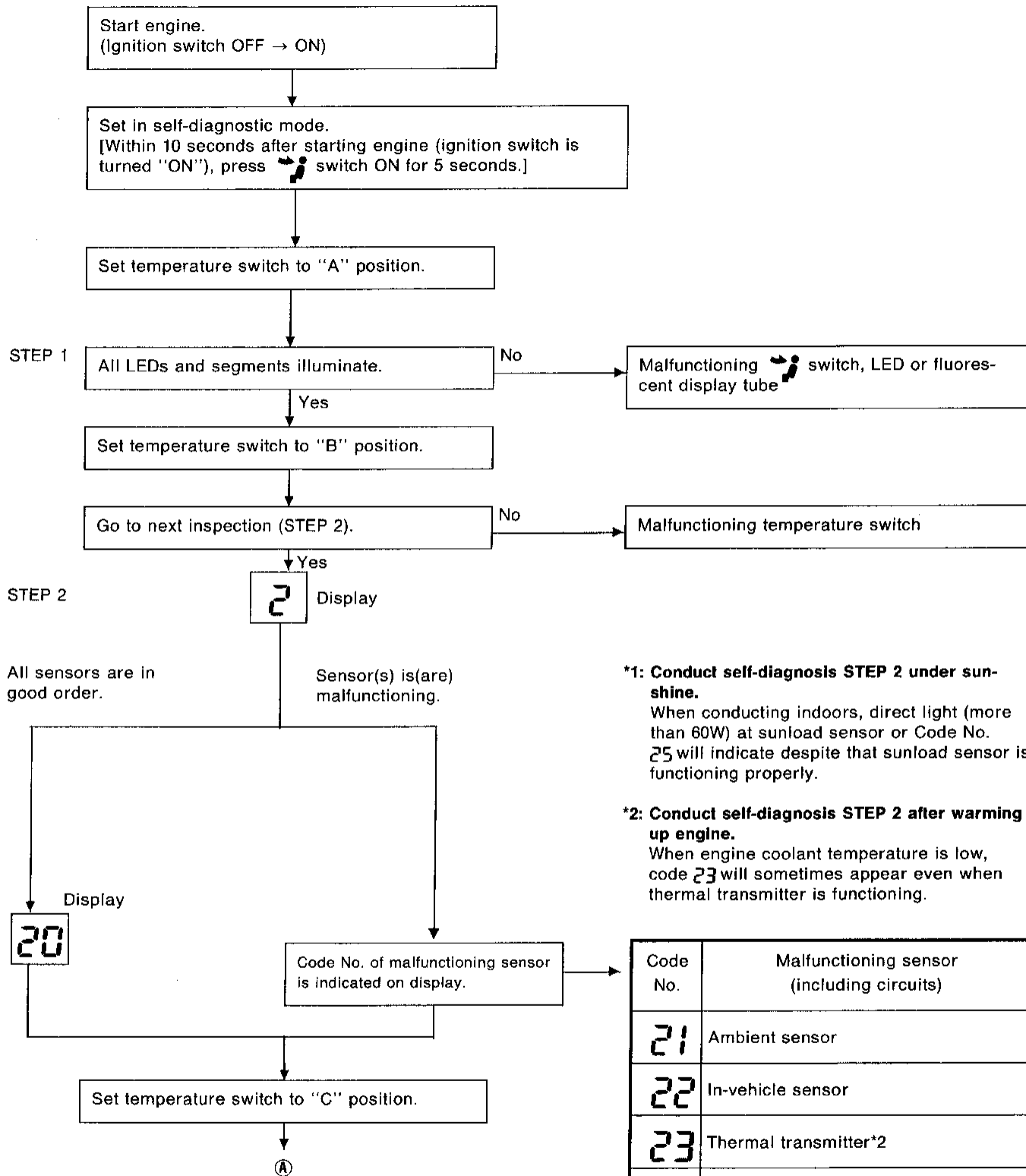

**\*1: Conduct self-diagnosis STEP 2 under sunshine.**  
When conducting indoors, direct light (more than 60W) at sunload sensor or Code No. 25 will indicate despite that sunload sensor is functioning properly.

**\*2: Conduct self-diagnosis STEP 2 after warming up engine.**  
When engine coolant temperature is low, code 23 will sometimes appear even when thermal transmitter is functioning.

Code No.	Malfunctioning sensor (including circuits)
21	Ambient sensor
22	In-vehicle sensor
23	Thermal transmitter*2
24	Intake sensor
25	Sunload sensor*1
26	PBR



# TROUBLE DIAGNOSES

## Self-diagnosis — ON-BOARD (Cont'd)

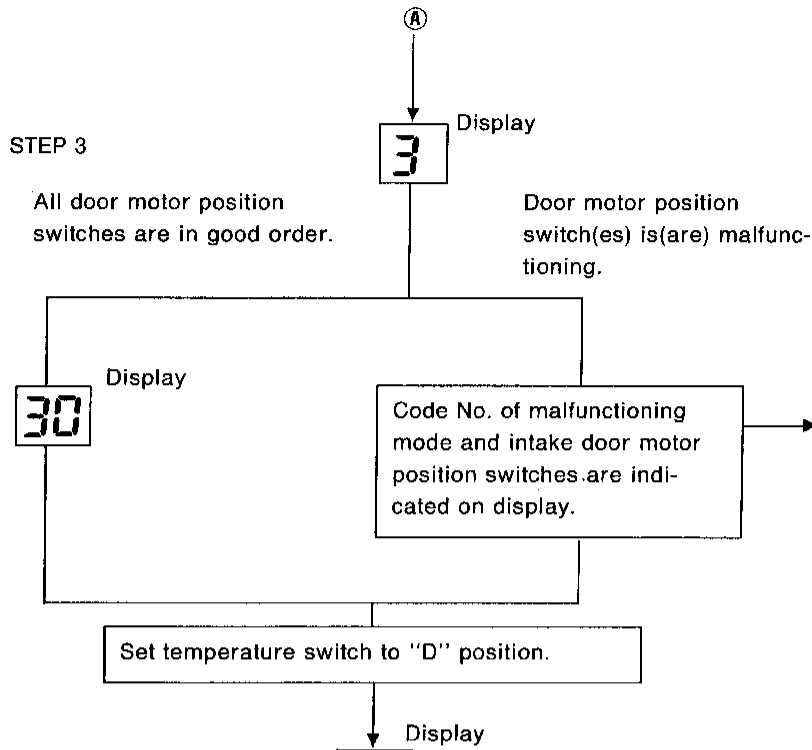

Code No.	Malfunctioning mode door motor position switch (including circuits)
31	VENT
32	B/L
33	FOOT/DEF 1
34	FOOT/DEF 2
35	DEF
36	FRE
37	80% FRE
38	20% FRE
39	REC

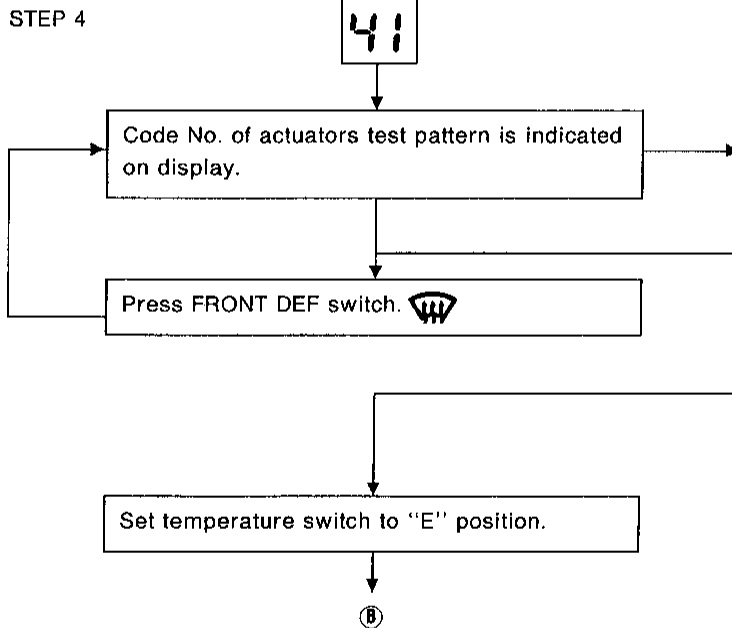

Code No.	Actuators test pattern					
	Mode door	Intake door	Air mix door	Blower motor	Com-pressor	Max. cold door
41	VENT	REC	Full Cold	4 - 5V	ON	Shut
42	B/L	20% FRE	Full Cold	9 - 11V	ON	Open
43	B/L	20% FRE	Full Hot	7 - 9V	OFF	Open
44	F/D 1	80% FRE	Full Hot	7 - 9V	OFF	Shut
45	F/D 2	FRE	Full Hot	7 - 9V	ON	Shut
46	DEF	FRE	Full Hot	10 - 12V	ON	Shut

GI  
MA  
EM  
LC  
EC  
FE  
AT  
PD  
FA  
RA  
BR  
ST  
RS  
BT  
HA  
EL  
IDX

# TROUBLE DIAGNOSES

## Self-diagnosis — ON-BOARD (Cont'd)

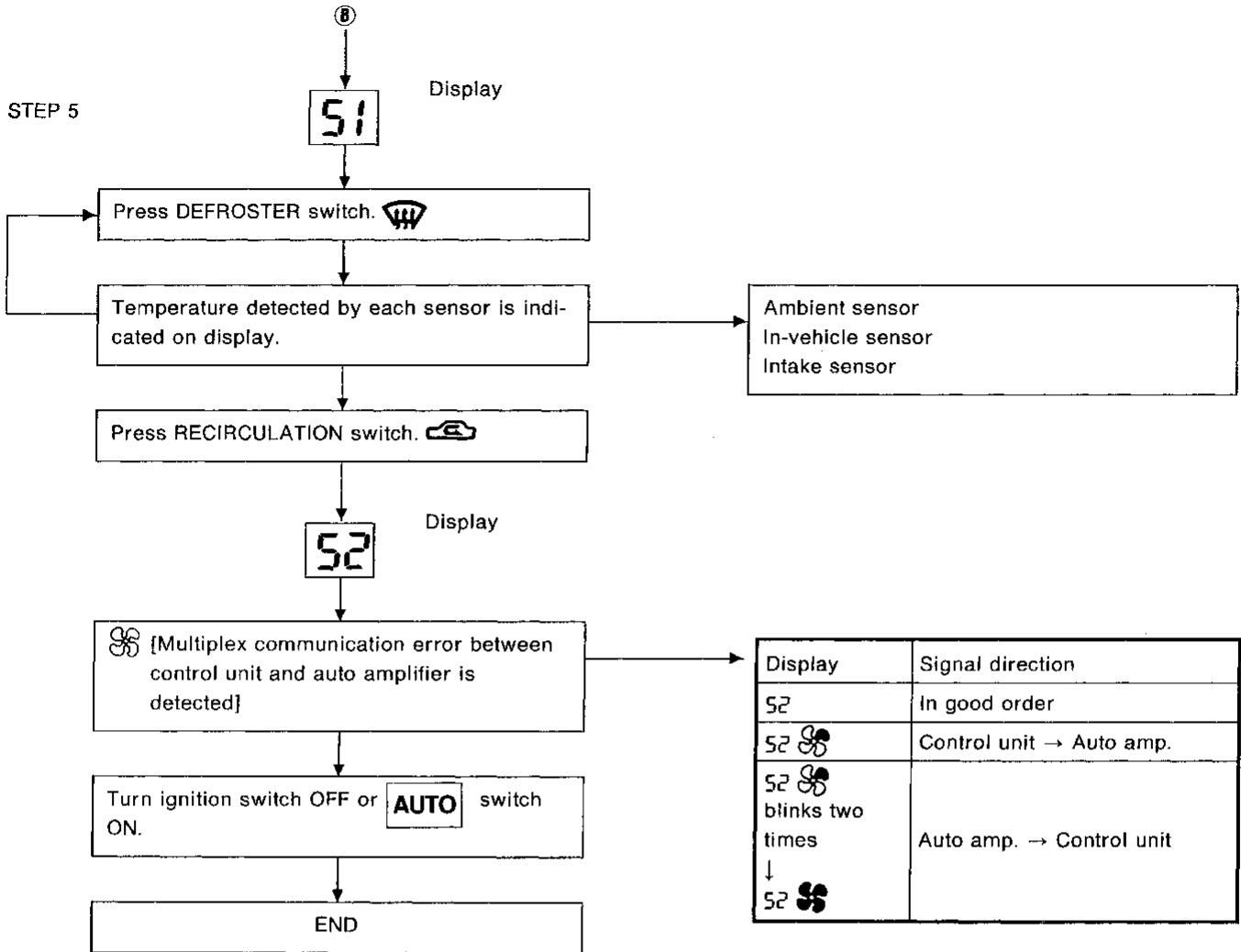

# TROUBLE DIAGNOSES

## Self-diagnosis — ON-BOARD (Cont'd)

### HOW TO INTERPRET THE RESULTS

#### STEP 1: Checks LEDs and segments

When switch's LED and segments are in good order in STEP 1 mode, the corresponding LED and fluorescent display tube will illuminate.

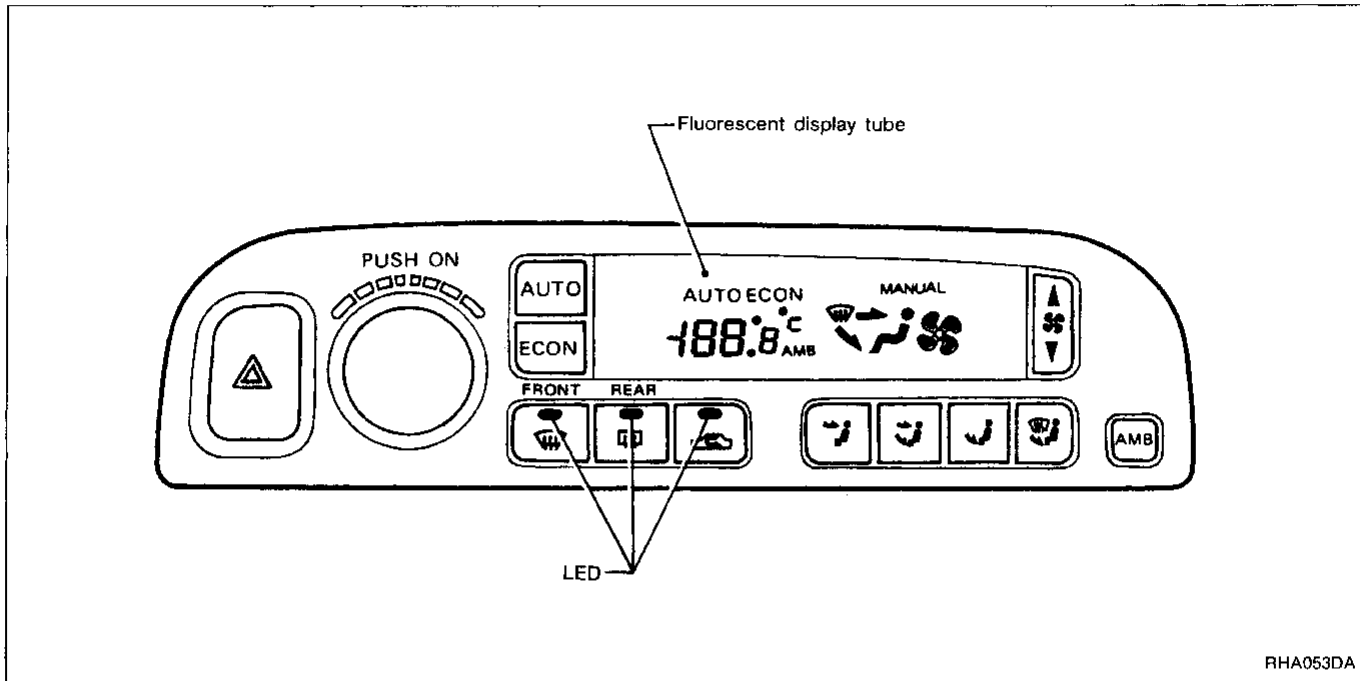

RHA053DA

#### Display malfunction

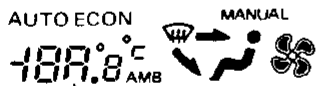

Part of segments does not illuminate.

RHA502A

If LEDs or segments malfunction, LED will not come on or display will show incomplete segment.

#### Display (when all sensors are in good order)

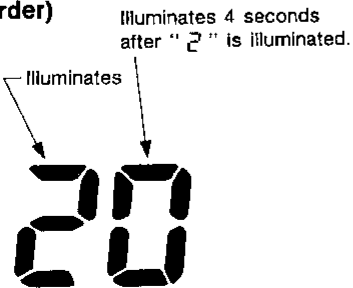

RHA499A

#### STEP 2: Checks each sensor circuit for open or short circuit

Display shows "2" in STEP 2 mode.

When all sensors are in good order, display shows "20".

It takes approximately 4 seconds to check all sensors.

GI

MA

EM

LC

EC

FE

AT

PD

FA

RA

BR

ST

RS

BT

HA

EL

IDX

## TROUBLE DIAGNOSES

### Self-diagnosis — ON-BOARD (Cont'd)

#### Display (when sensor malfunctions)

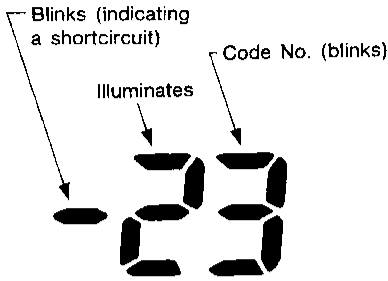

RHA500A

If a sensor is malfunctioning, the corresponding code No. blinks on display. A short circuit is identified by a blinking “-” mark preceding mode number.

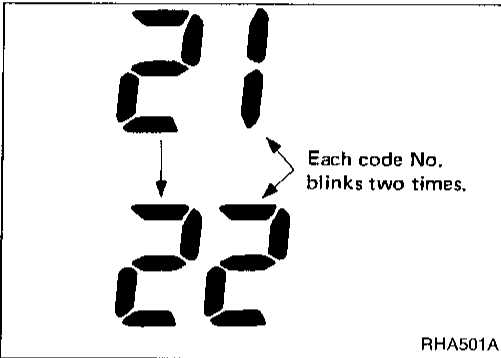

RHA501A

If two or more sensors malfunction, corresponding code Nos. respectively blink two times.

#### Sensors and abnormalities

If a circuit is opened or shorted, display shows its code No. when input corresponds with any of following conditions.

Code No.	Sensor	Open circuit	Short circuit
21	Ambient sensor	Less than -41.9°C (-43°F)	Greater than 100°C (212°F)
22	In-vehicle sensor	Less than -41.9°C (-43°F)	Greater than 100°C (212°F)
23	Thermal transmitter*3	Less than -25.6°C (-14°F)	Greater than 150°C (302°F)
24	Intake sensor	Less than -41.9°C (-43°F)	Greater than 100°C (212°F)
25	Sunload sensor*2	Less than 0.01515 mA	Greater than 0.545 mA
26	PBR*1	Greater than 50%	Less than 30%

\*1: “50%” and “30%” refer to percentage with respect to full stroke of air mix door. (Full cold: 0%, Full hot: 100%)

\*2: **Conduct self-diagnosis STEP 2 under sunshine.**

When conducting indoors, direct light (more than 60W) at sunload sensor.

\*3: **Conduct self-diagnosis STEP 2 after warming up engine.**

#### Display (when all doors are in good order)

Illuminates 20 seconds after “3” is shown on display.

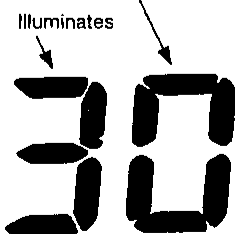

RHA383D

#### STEP 3: Checks mode and intake door positions

Display shows “3” in STEP 3 mode.

When all doors are in good order, display will then show “30”.

**It takes approximately 20 seconds to check all mode and intake doors.**

## TROUBLE DIAGNOSES

### Self-diagnosis — ON-BOARD (Cont'd)

When abnormalities are detected, display shows a code No. corresponding with malfunctioning part.

Code No.	<b>31</b>	<b>32</b>	<b>33</b>	<b>34</b>	<b>35</b>	<b>36</b>	<b>37</b>	<b>38</b>	<b>39</b>
Malfunc-tioning part	VENT	B/L	F/D 1	F/D 2	DEF	FRE	80% FRE	20% FRE	REC

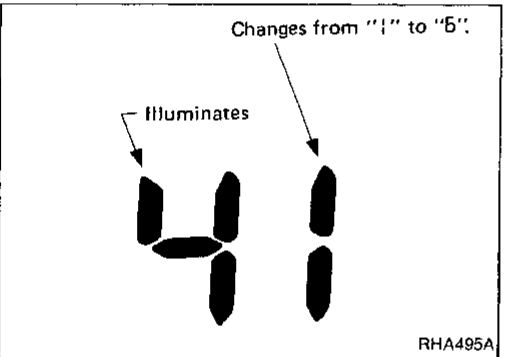
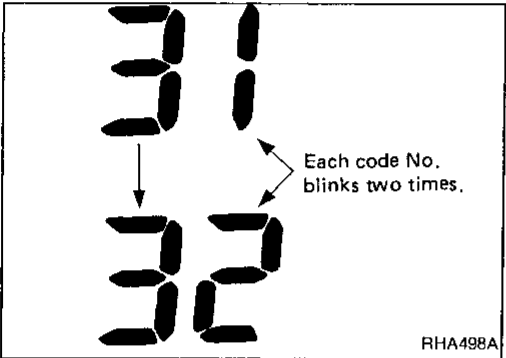
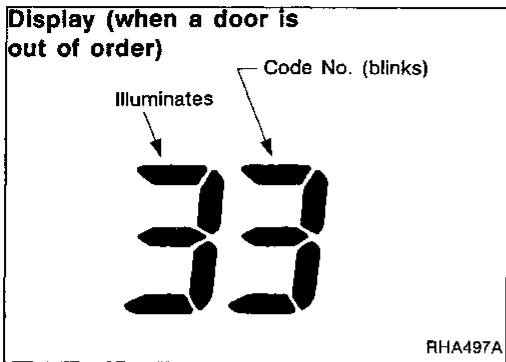

If two or more mode or intake doors are out of order, corresponding code numbers respectively blink two times.

If mode door motor harness connector is disconnected, the following display pattern will appear.

31 → 32 → 33 → 34 → 35

If intake mode door harness connector is disconnected, the following display pattern will appear.

36 → 37 → 38 → 39

If any mode door motor position switch is malfunctioning, mode door motor will also malfunction.

#### STEP 4: Checks operation of each actuator

Display shows "41" in STEP 4 mode.

When DEFROSTER switch is pressed one time, display shows

"42". Thereafter, each time the switch is pressed, display advances one number at a time, up to "46", then returns to "41".

During inspection in STEP 4, the auto amplifier will forcefully transmit an output to the affected actuators. The corresponding code Nos. are shown on display as indicated in the table below.

**Checks must be made visually, by listening to any noise, or by touching air outlets with your hand, etc. for improper operation.**

Code No.	<b>41</b>	<b>42</b>	<b>43</b>	<b>44</b>	<b>45</b>	<b>46</b>
Actuator	VENT	B/L	B/L	F/D 1	F/D 2	DEF
Mode door	VENT	B/L	B/L	F/D 1	F/D 2	DEF
Intake door	REC	20% FRE	20% FRE	80% FRE	FRE	FRE
Air mix door	Full Cold	Full Cold	Full Hot	Full Hot	Full Hot	Full Hot
Blower motor	4 - 5 V	9 - 11 V	7 - 9 V	7 - 9 V	7 - 9 V	10 - 12 V
Compressor	ON	ON	OFF	OFF	ON	ON
Max. cold door	Shut	Open	Open	Shut	Shut	Shut

Operating condition of each actuator cannot be checked by indicators.





## TROUBLE DIAGNOSES

### Self-diagnosis — ON-BOARD (Cont'd)

#### STEP 5: Checks temperature detected by sensors, and detects multiplex communication error

##### Checks temperature detected by sensors

Display shows "51" in STEP 5 mode.

- When  DEFROSTER switch is pressed one time, display shows temperature detected by ambient sensor.
- When  DEFROSTER switch is pressed second time, display shows temperature detected by in-vehicle sensor.
- When  DEFROSTER switch is pressed third time, display shows temperature detected by intake sensor.
- When  DEFROSTER switch is pressed fourth time, display returns to original presentation "51".

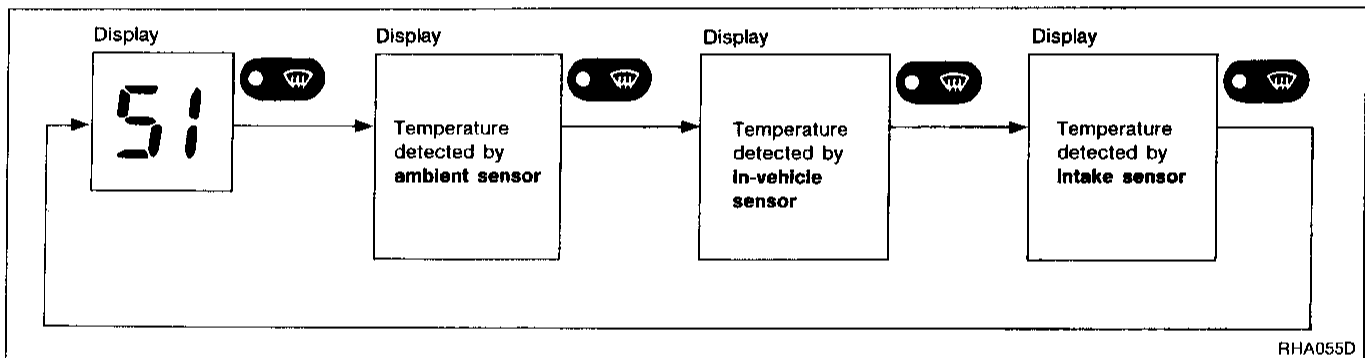
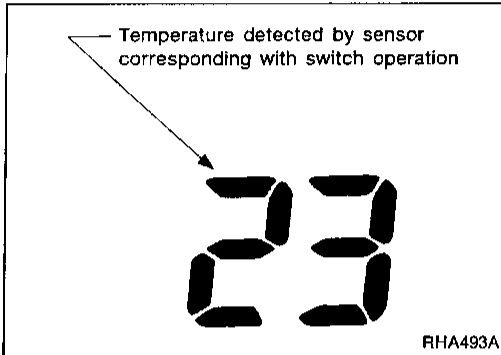
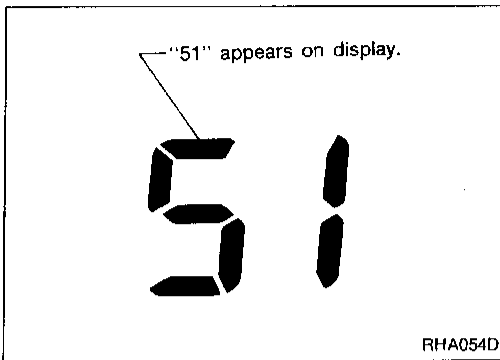

If temperature shown on display greatly differs from actual temperature, check sensor circuit at first. Then inspect sensor itself according to the procedures described in **Control System Input Components (Refer to HA-104)**.

# TROUBLE DIAGNOSES

## Self-diagnosis — ON-BOARD (Cont'd)

### Detects multiplex communication error

Display shows "52" in STEP 5 mode.

[Multiplex communication error between control unit and auto amplifier is detected]

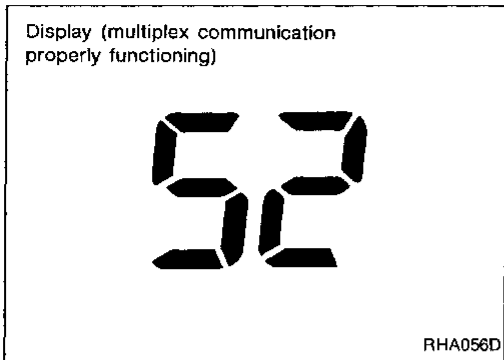

Display	Signal direction	
52	In good order	GI
52	Control unit → auto amplifier	MA
52 blinks two times. ↓	Auto amplifier → control unit	EM
52		LC
52		EC
		FE

**CAUTION:**

The auto amplifier memorizes any communication error in the system in a normal control with battery connected.

When there is an error, display will be as shown above.

When plural errors occur, the display of each error will blink two times for 0.5 second intervals.

If a communication error is displayed, follow the flow chart below to judge if the error occurred in the past or is currently happening.

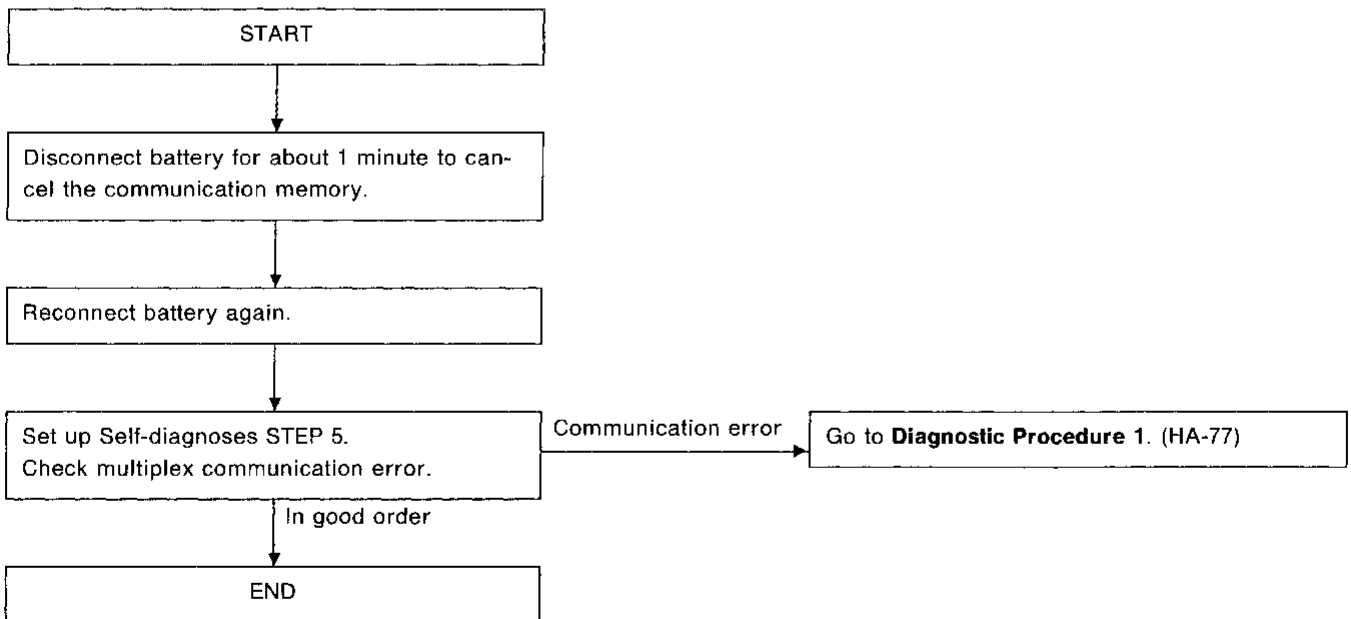

## TROUBLE DIAGNOSES

### Self-diagnosis — ON-BOARD (Cont'd)

#### AUXILIARY MECHANISM: Temperature setting trimmer

This trimmer compensates for differences between temperature setting (displayed digitally) and temperature felt by driver in a range of  $\pm 3^{\circ}\text{C}$  ( $\pm 6^{\circ}\text{F}$ ).

Operating procedures for this trimmer are as follows:

Starting with STEP 5 under "Self-diagnostic mode", press

 (fan up) switch to set air conditioning system in auxiliary mode. Then, set temperature switch to desired temperature. Temperature will change at a rate of  $0.5^{\circ}\text{C}$  ( $1^{\circ}\text{F}$ ) each time a switch is turned.

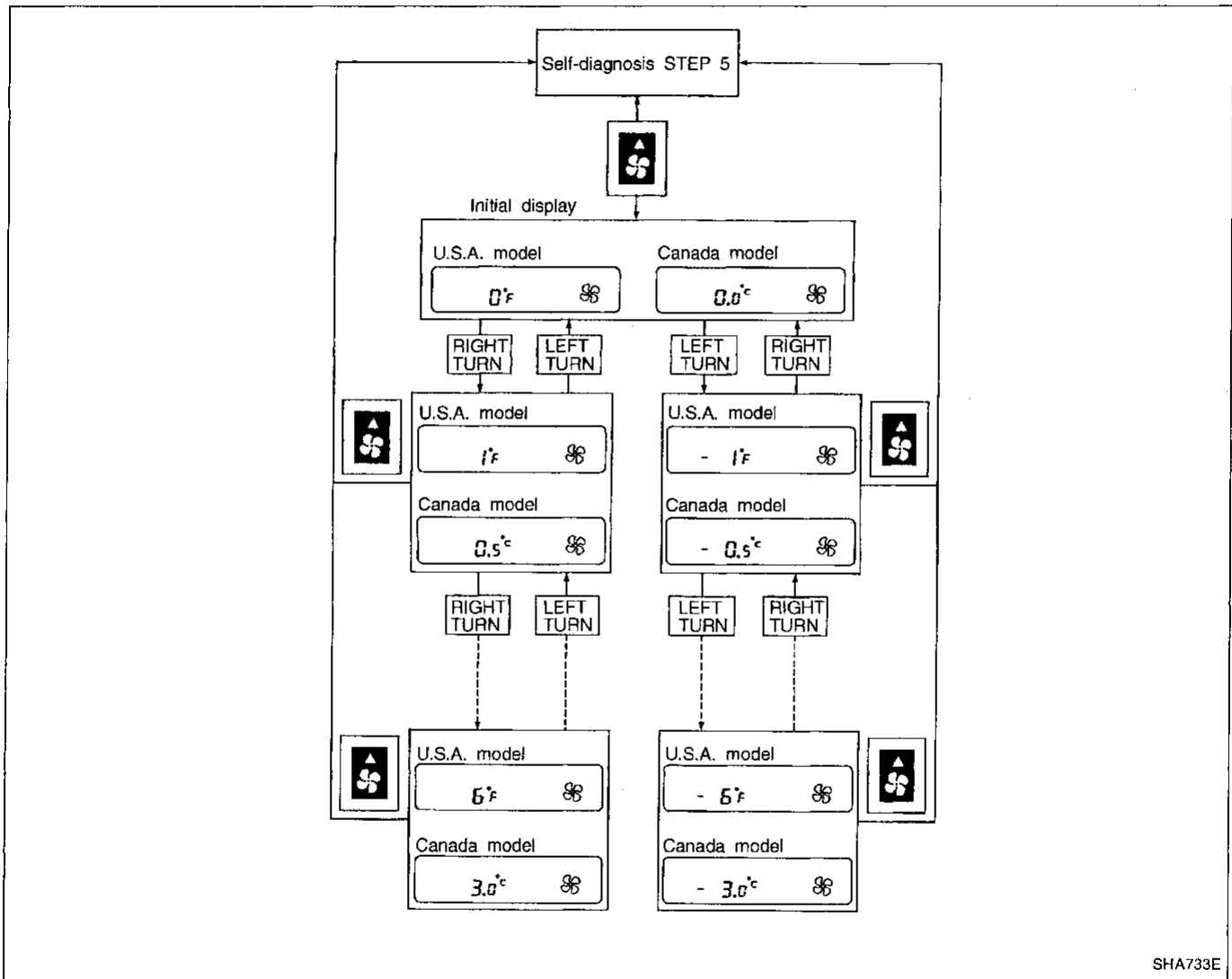

When battery cable is disconnected, trimmer operation is canceled and temperature set becomes that of initial condition, i.e.  $0^{\circ}\text{C}$  ( $0^{\circ}\text{F}$ ).



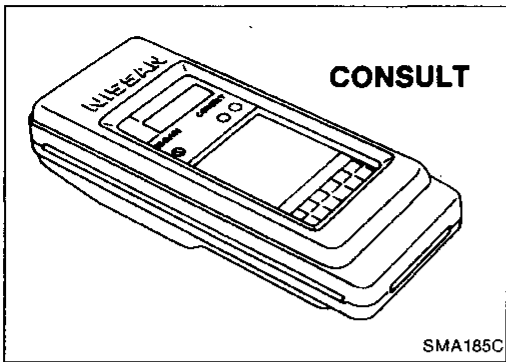

## Self-diagnosis — CONSULT

### CONSULT INSPECTION PROCEDURE

1. Turn off ignition switch.
2. Connect "CONSULT" to Data link connector. (Data link connector is located in left dash side panel.)

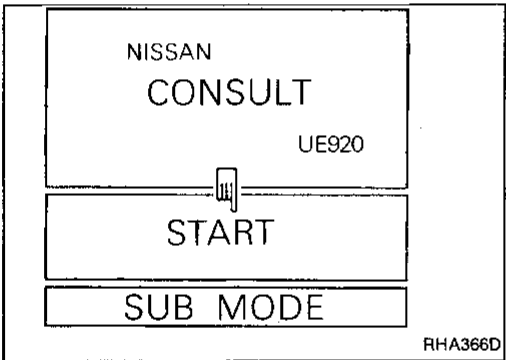
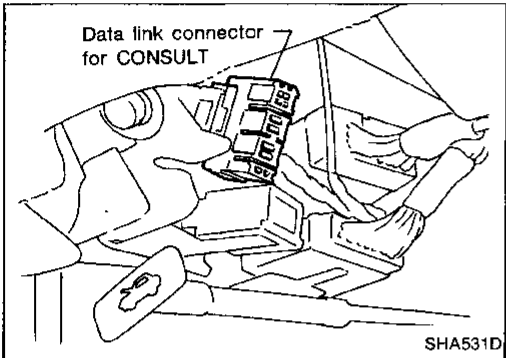

3. Turn on ignition switch.
4. Touch "START".

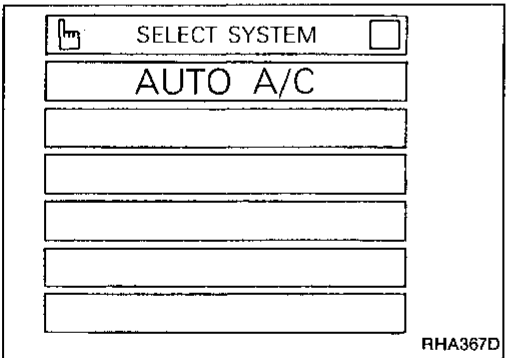

5. Touch "AUTO A/C".

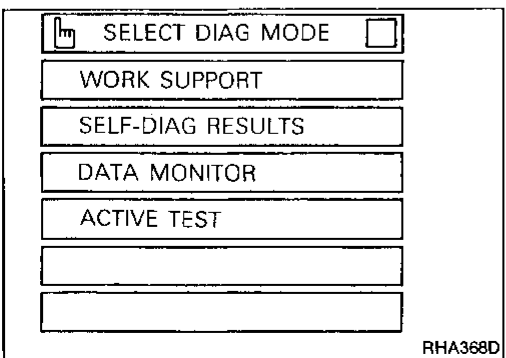

6. Perform each diagnostic mode according to the inspection sheet on the next page.

GI

MA

EM

IC

EC

FE

AT

PD

FA

RA

BR

ST

RS

BT

HA

EL

IDX

## TROUBLE DIAGNOSES

### Self-diagnosis — CONSULT (Cont'd)

#### WORK SUPPORT

#### SEGMENT CHECK: Checks LEDs and segments

Touch "SEGMENT CHECK".

When switch's LED and segments are in good order in WORK SUPPORT — Segment check mode, the corresponding LED and fluorescent display tube will illuminate.

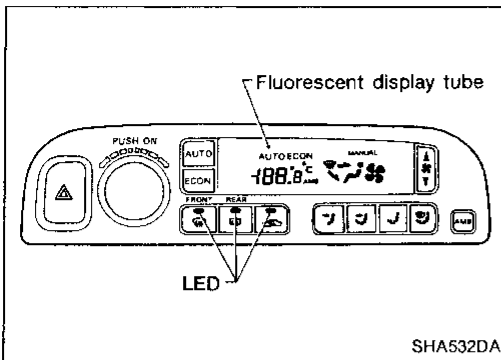

#### Display malfunction

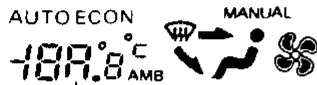

If LEDs or segments malfunction, LED will not come on or display will show incomplete segment.

■ MODE DOOR CHECK ■

FAILURE DETECTED

\*\*\*\* NO FAILURE \*\*\*\*

PRINT

RHA369D

#### MODE DOOR CHECK: Checks mode door position

Touch "MODE DOOR CHECK" and then touch "START". When all doors are functioning, display will show "NO FAILURE".

■ MODE DOOR CHECK ■

FAILURE DETECTED

VENT

B/L1

PRINT

RHA370D

When abnormalities are detected, display shows a malfunction position.

If two or more mode doors are out of order, corresponding mode doors respectively blink two times.

If any mode door motor harness connector is disconnected, display will show all mode door positions.

If any mode door motor position switch is malfunctioning, mode door motor will also malfunction.

# TROUBLE DIAGNOSES

## Self-diagnosis — CONSULT (Cont'd)

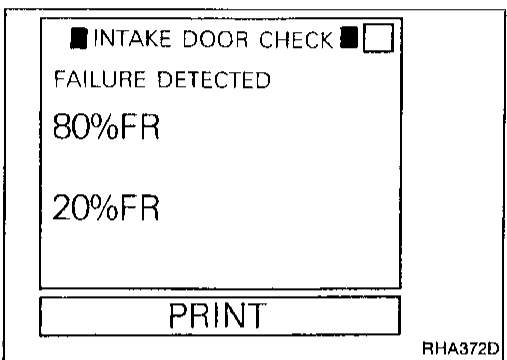
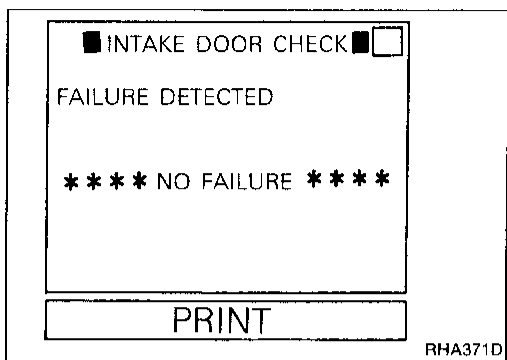

### INTAKE DOOR CHECK: Checks intake door position.

Touch "INTAKE DOOR CHECK", and then touch "START". When all doors are in good order, display will show "NO FAILURE".

When abnormalities are detected, display shows a malfunction position.

If two or more intake doors are out of order, corresponding intake doors respectively blink two times.

If intake door motor harness connector is disconnected, display will show all positions except "FRE".

If any intake door motor position switch is malfunctioning, intake door motor will also malfunction.

### TEMP SETTING TRIMMER: Temperature setting trimmer.

This trimmer compensates for differences between temperature setting (Displayed digitally) and temperature felt by the driver in a range of  $\pm 3^{\circ}\text{C}$  ( $\pm 6^{\circ}\text{F}$ ).

Operation procedures for this trimmer are as follows:

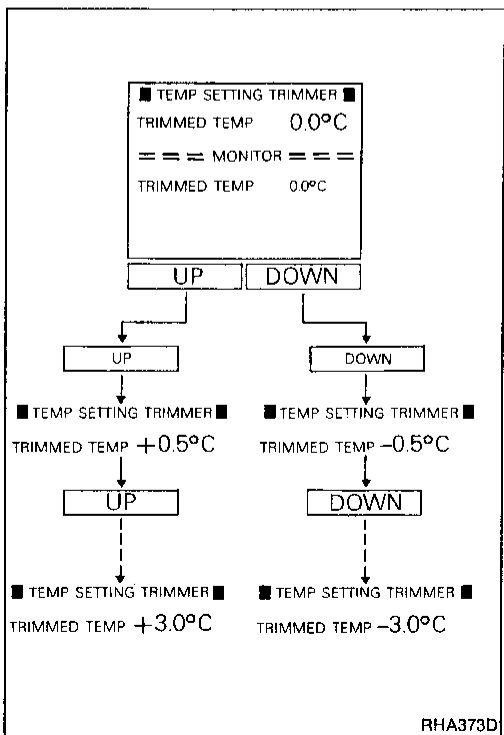

Touch "TEMP SETTING TRIMMER", and then touch "START". Next, touch either the UP or DOWN switch as desired.

Temperature will change at a rate of  $0.5^{\circ}\text{C}$  ( $1^{\circ}\text{F}$ ) each time a switch is touch.

When battery cable is disconnected, trimmer operation is canceled and temperature set returns to the initial condition, i.e.  $0^{\circ}\text{C}$  ( $0^{\circ}\text{F}$ ).

GI

MA

EM

LC

EC

FE

AT

PD

FA

RA

BR

ST

RS

BT

HA

EL

IDX

## TROUBLE DIAGNOSES

### Self-diagnosis — CONSULT (Cont'd)

#### MAX. OUTLET FLOW ADJUSTMENT: Adjustment of highest blower fan speed.

For passenger's comfort, maximum air flow of automatic control (blower motor voltage) can be set at three different levels. Operating procedure for this adjustment are as follows:  
Touch "MAX OUTLET FLOW ADJUSTMENT", and touch "START". Then, touch either UP or DOWN switch as desired.

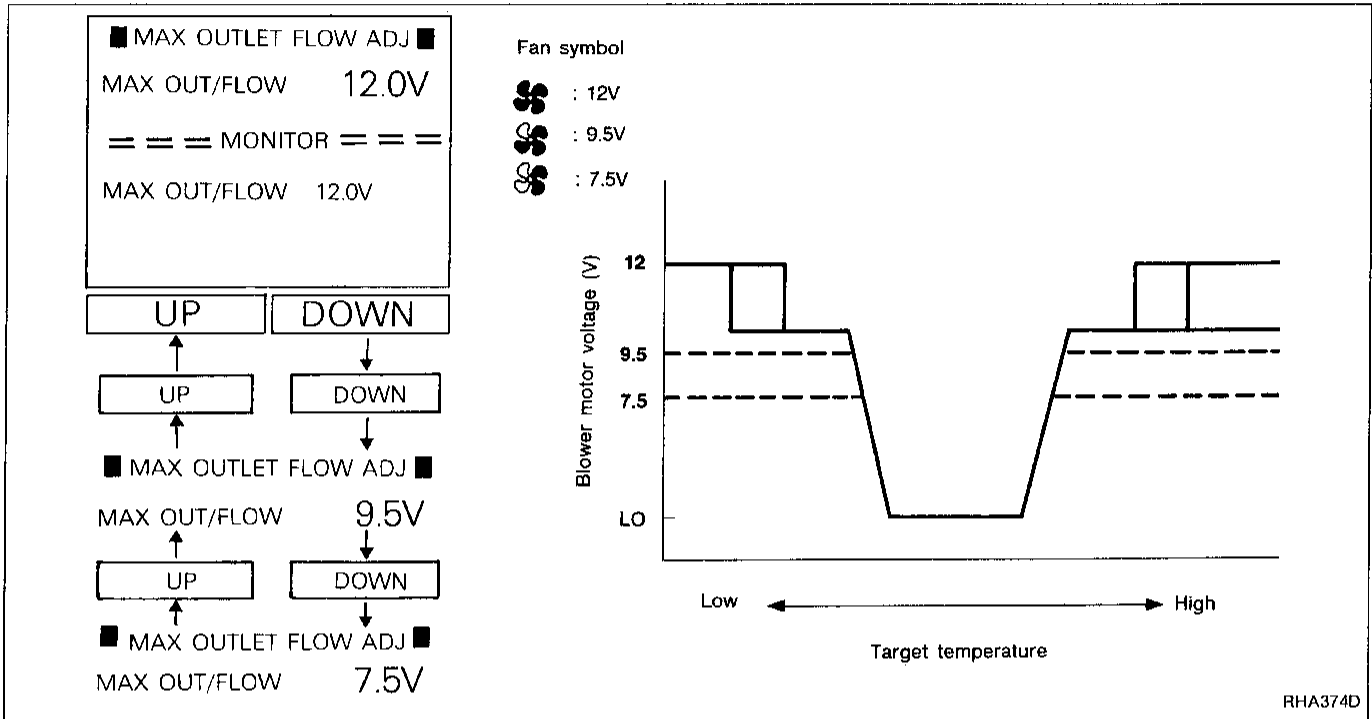

#### FAN SPEED CONTROL ADJUSTMENT: Adjustment of highest blower fan speed changing point.

For passenger's comfort, blower high relay operating time period during cool down (voltage changes from 12V to 10.5V) can be set at three different levels.

Operating procedure for this adjustment are as follows:  
Touch "FAN SPEED CONTROL ADJUSTMENT", and touch "START". Then, touch either UP or DOWN switch as desired.

# TROUBLE DIAGNOSES

## Self-diagnosis — CONSULT (Cont'd)

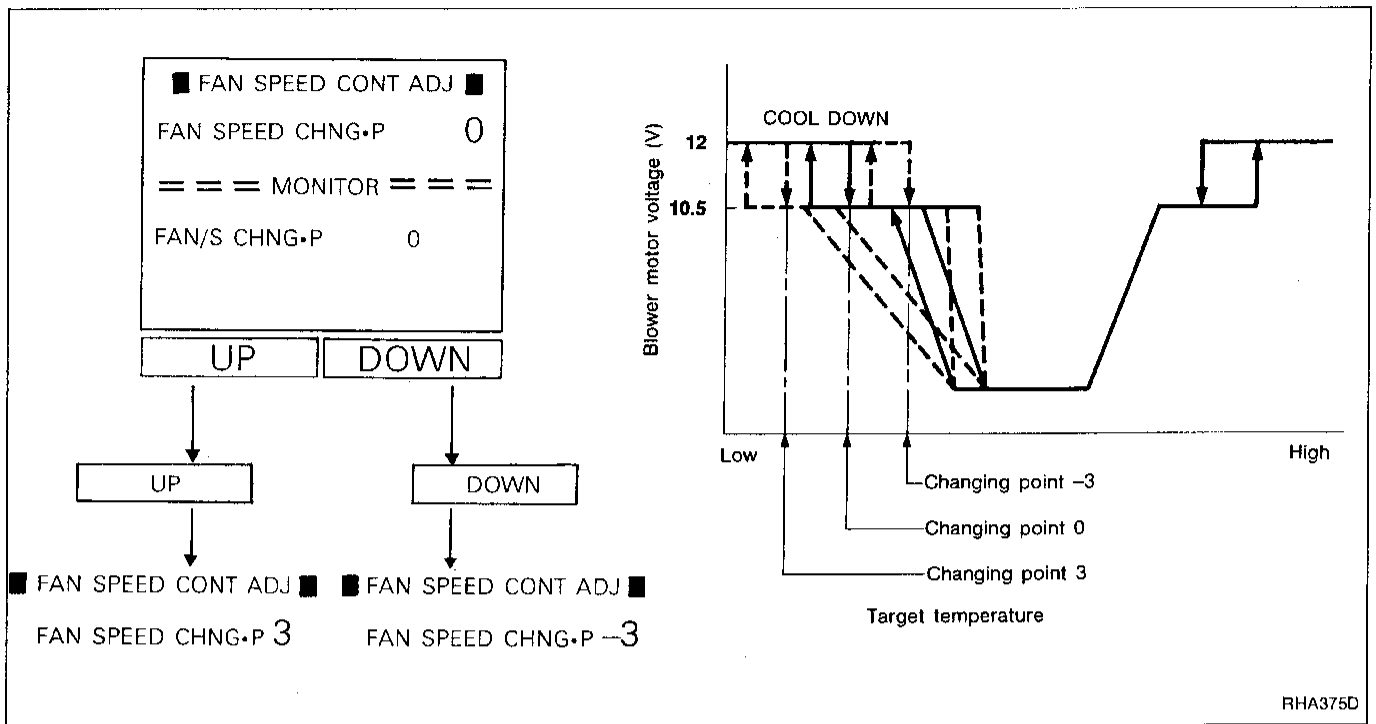

### MODE DOOR CONTROL ADJUSTMENT: Adjusting outlet door changing point.

For passenger's comfort, time setting when changing from B/L to F/D mode can be set at three different levels. (Operating procedure for this adjustment are as follows:) Touch "MODE DOOR CONTROL ADJUSTMENT", and then touch "START". Then, touch UP switch as desired.

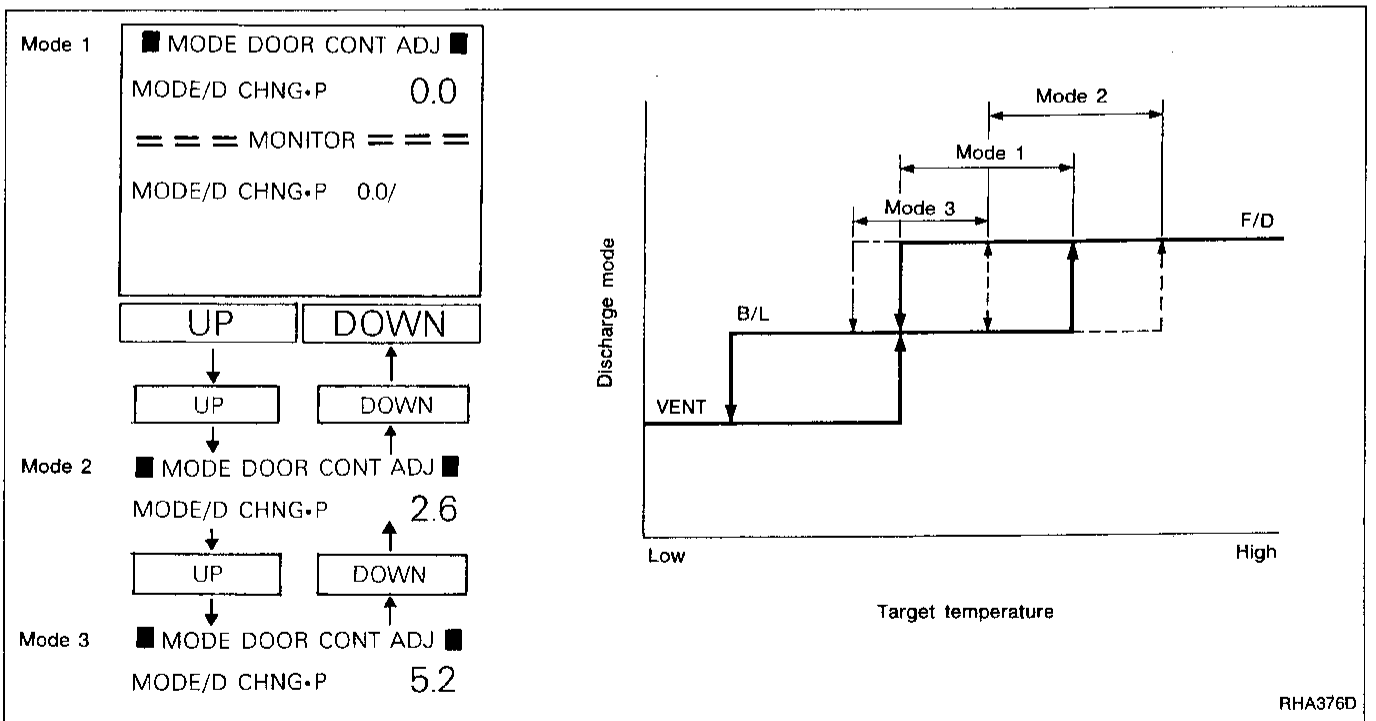

## TROUBLE DIAGNOSES

### Self-diagnosis — CONSULT (Cont'd)

#### SELF-DIAGNOSTIC RESULTS

Checks each sensor circuit for open or short circuit.

DIAGNOSTIC ITEM	DIAGNOSTIC ITEM IS DETECTED WHEN ...
Ambient sensor	Each sensor circuit is open or shorted.
In-vehicle sensor	
Engine coolant temperature sensor (Thermal transmitter)	
Intake sensor	
Sunload sensor	
PBR	

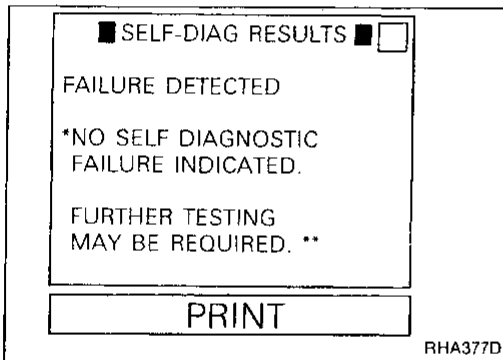

Touch "SELF-DIAGNOSTIC RESULTS", and then touch "START". When all sensors are in good order, display will show "NO SELF DIAGNOSTIC FAILURE INDICATED".

#### CAUTION:

- Before conducting SELF-DIAGNOSTIC RESULTS mode, warm up engine. When engine coolant temperature is low, display can sometimes show "WATER TEMPERATURE SENSOR [OPEN] (-a)" even though the sensor is functioning properly.
- Conduct SELF-DIAGNOSTIC RESULTS mode under direct sunshine if possible. When conducting indoors, direct electric light (min. 60W) on the sunload sensor. Otherwise, display will show "SUNLOAD SENSOR [OPEN] (-a)" even when the sensor is functioning properly.

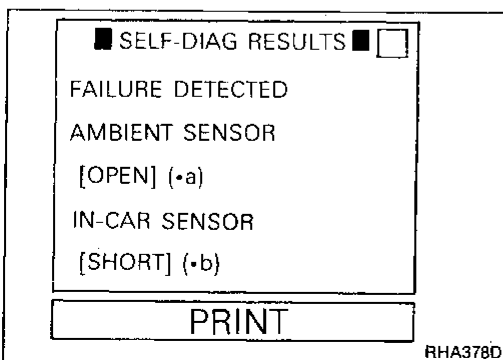

If a sensor is malfunctioning, the corresponding sensor on display.

If circuit is opened, [OPEN] (-a)

If circuit is shorted, [SHORT] (-b)

# TROUBLE DIAGNOSES

## Self-diagnosis — CONSULT (Cont'd)

### DATA MONITOR

Input/Output data in the auto amp. is displayed. Touch "DATA MONITOR".

☆ MONITOR	☆ NO FAIL	☆ MONITOR	☆ NO FAIL
AMBIENT SEN	19.0°C	FR DEF SW	→
IN-CAR SEN	25.0°C	RR DEF SW	→
INTAKE SENSOR	5.6°C	AMBIENT SW	→
SUNLOAD SEN	670.0kcal	VENT SW	→
COOLANT TEMP/S	↑50°C	B/L SW	→
AUTO SW	→	D/F1 SW	→
ECON SW	→	D/F2 SW	→
OFF SW	→	FAN UP SW	→
REC SW	→	FAN DOWN SW	→
RECORD		RECORD	

SHA634E

### ECU Input signals

Touch "ECU INPUT SIGNALS".

### Switch communication check

For switches shown on the display, press applicable switch on control unit. When the direction of the arrow "→" changes, switch communication is in functioning properly.

### Main signals

Touch "MAIN SIGNALS", and touch "START".

☆ MONITOR	☆ NO FAIL	☆ MONITOR	☆ NO FAIL
AMBIENT SEN	19.0°C	COMPRESSOR	OFF
IN-CAR SEN	25.0°C	TRIMMED TEMP	0.0°C
INTAKE SENSOR	5.6°C	IN/POS MEMORY	OFF
SUNLOAD SEN	670.0kcal	MAX OUT/FLOW	12.0V
COOLANT TEMP/S	↑50°C	FAN/S CHNG-P	0
MODE DOOR POS	D/F1	MODE/D CHNG-P	0.0'
INTAKE DOOR/P	FRESH		
A/M DOOR ANGL	65.4%		
BLOWER MOTOR	0.00V		
RECORD		RECORD	

SHA635E

### Selection from menu.

Touch "SELECTION FROM MENU".

These are the available items to be checked:

- AMBIENT SENSOR
- IN-CAR (IN-VEHICLE) SENSOR
- INTAKE SENSOR
- SUNLOAD SENSOR
- COOLANT TEMP. SENSOR  
(THERMAL TRANSMITTER)
- AUTO SW
- ECON SW
- OFF SW
- REC SW
- FR DEF SW
- RR DEF SW
- AMBIENT SW
- VENT SW
- B/L SW
- D/F1 SW
- D/F2 SW
- FAN UP SW
- FAN DOWN SW
- MODE DOOR POSITION
- INTAKE DOOR POSITION
- AIR MIX DOOR ANGLE
- BLOWER MOTOR
- COMPRESSOR
- TRIMMED TEMP.  
(TEMP. SETTING TRIMMER)
- MAX. OUTLET FLOW
- FAN SPEED CHANGING POINT
- MODE DOOR CHANGING POINT

GI

WA

EM

LC

EC

FE

AT

PD

FA

RA

BR

ST

RS

BT

HA

EL

DX

# TROUBLE DIAGNOSES

## Self-diagnosis — CONSULT (Cont'd)

### ACTIVE TEST

Checks operation of each actuator.

Mode in which CONSULT drives some actuators apart from the auto amp. and also shifts some parameters in a specified range.

**Checks must be made visually, by listening for noise, or by touching air outlets with hand, etc. for improper operation.**

Touch "ACTIVE TEST".

Touch "COMPLEX PATTERNS".

Touch "START". Display shows STEP 1 in "ACTIVE TEST" mode.

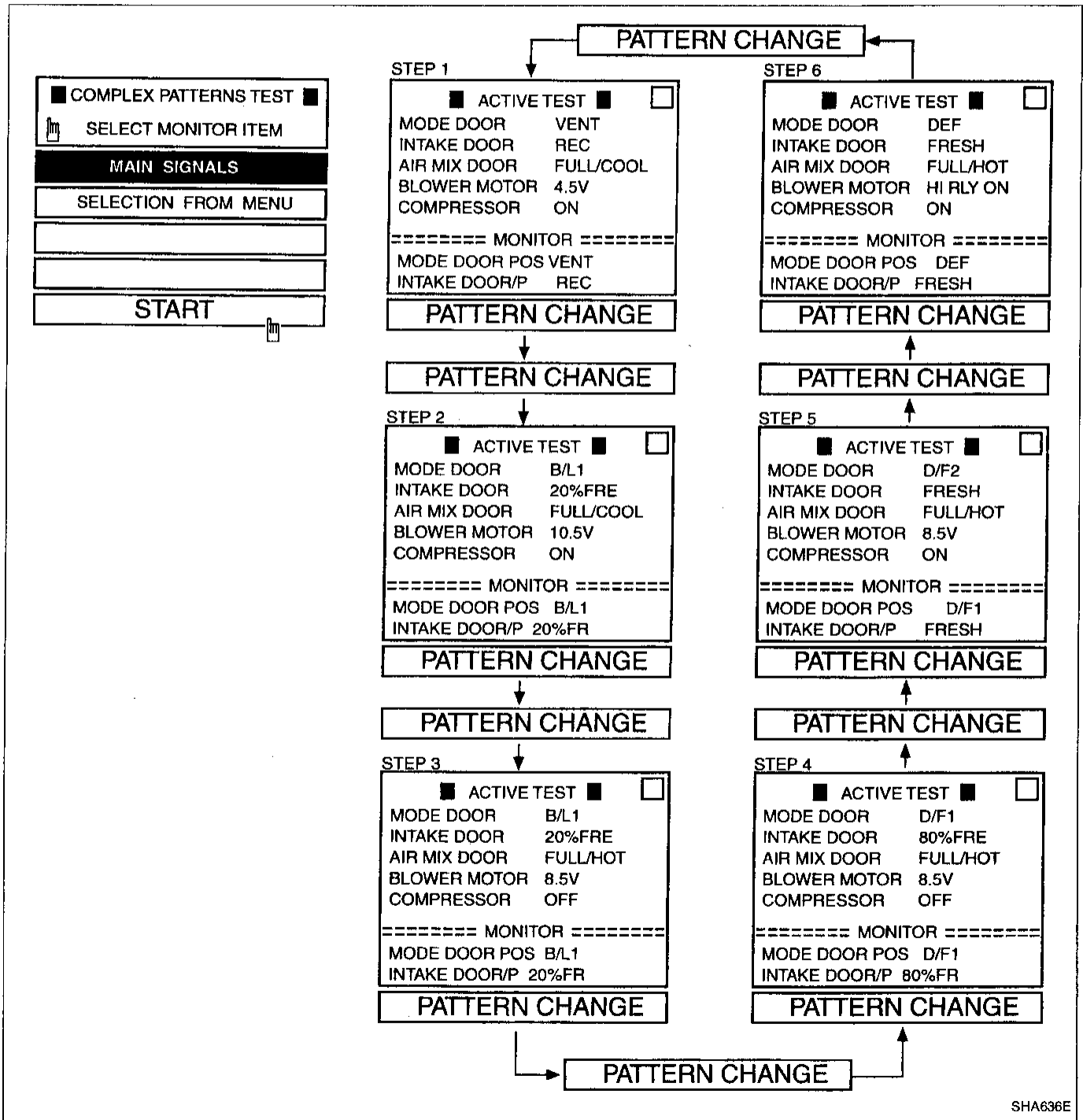

SHA636E



# TROUBLE DIAGNOSES

## Preliminary Check

### PRELIMINARY CHECK 1

#### Air outlet does not change

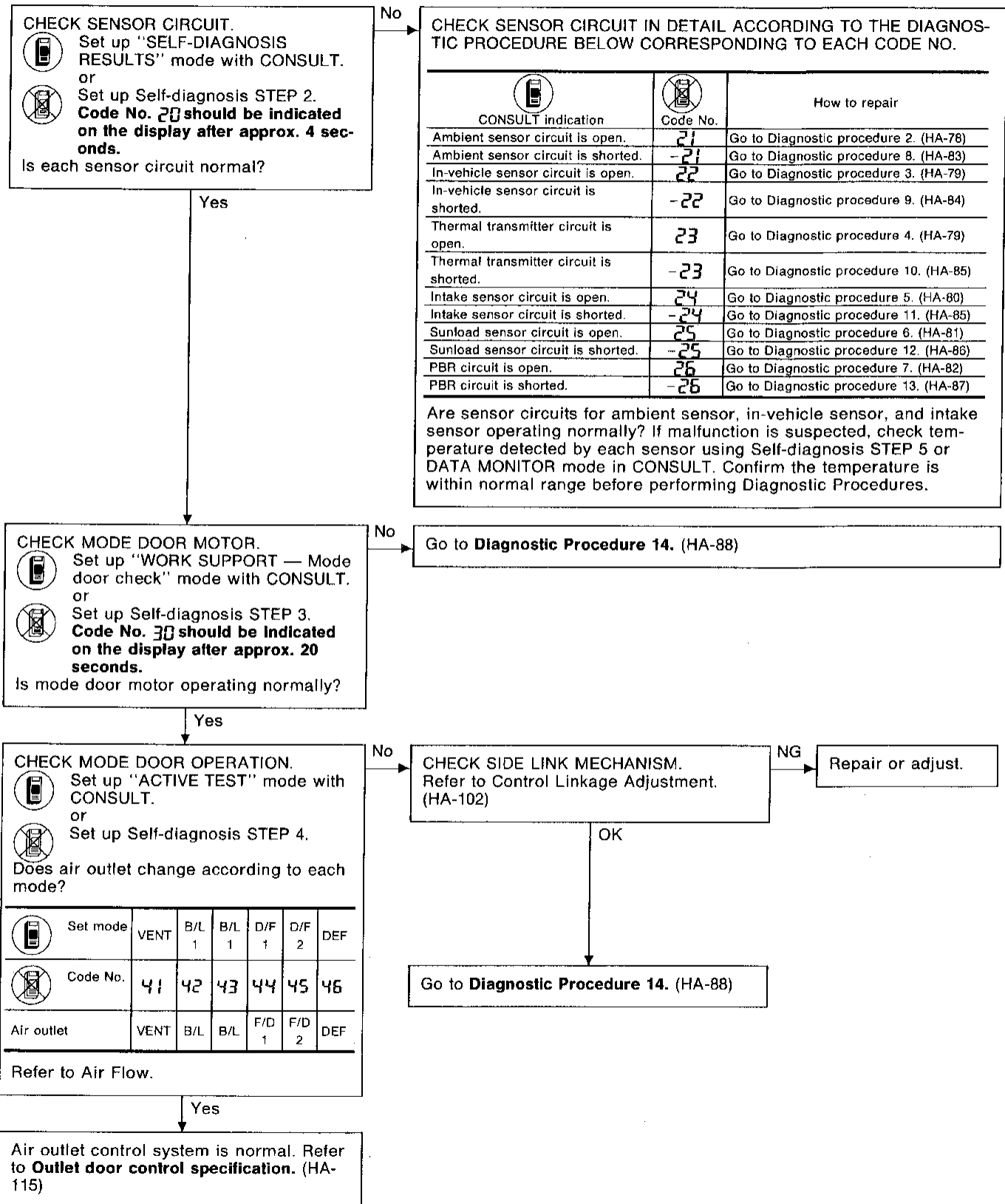



GI  
MA  
EM  
LC  
EC  
FE  
AT  
PD  
FA  
RA  
BR  
ST  
RS  
BT  
HA  
EL  
IDX

# TROUBLE DIAGNOSES

## Preliminary Check (Cont'd)



### PRELIMINARY CHECK 2

**Intake door does not change.**

**CHECK SENSOR CIRCUIT.**  
 Set up "SELF-DIAGNOSIS RESULTS" mode with CONSULT.  
 or  
 Set up Self-diagnosis STEP 2.  
**Code No. 20 should be indicated on the display after approx. 4 seconds.**  
 Is each sensor circuit normal?



No →

**CHECK SENSOR CIRCUIT IN DETAIL ACCORDING TO THE DIAGNOSTIC PROCEDURE BELOW CORRESPONDING TO EACH CODE NO.**

 CONSULT indication	 Code No.	How to repair
Ambient sensor circuit is open.	21	Go to Diagnostic procedure 2. (HA-78)
Ambient sensor circuit is shorted.	-21	Go to Diagnostic procedure 8. (HA-83)
In-vehicle sensor circuit is open.	22	Go to Diagnostic procedure 3. (HA-79)
In-vehicle sensor circuit is shorted.	-22	Go to Diagnostic procedure 9. (HA-84)
Thermal transmitter circuit is open.	23	Go to Diagnostic procedure 4. (HA-79)
Thermal transmitter circuit is shorted.	-23	Go to Diagnostic procedure 10. (HA-85)
Intake sensor circuit is open.	24	Go to Diagnostic procedure 5. (HA-80)
Intake sensor circuit is shorted.	-24	Go to Diagnostic procedure 11. (HA-85)
Sunload sensor circuit is open.	25	Go to Diagnostic procedure 6. (HA-81)
Sunload sensor circuit is shorted.	-25	Go to Diagnostic procedure 12. (HA-86)
PBR circuit is open.	26	Go to Diagnostic procedure 7. (HA-82)
PBR circuit is shorted.	-26	Go to Diagnostic procedure 13. (HA-87)

Are sensor circuits for ambient sensor, in-vehicle sensor, and intake sensor operating normally? If malfunction is suspected, check temperature detected by each sensor using Self-diagnosis STEP 5 or DATA MONITOR mode in CONSULT. Confirm the temperature is within normal range before performing Diagnostic Procedures.



Yes



**CHECK INTAKE DOOR MOTOR.**  
 Set up "WORK SUPPORT — Intake door check" mode with CONSULT.  
 or  
 Set up Self-diagnosis STEP 3.  
**Code No. 30 should be indicated on the display after approx. 20 seconds.**  
 Is intake door motor operating normally?

No →

**Go to Diagnostic Procedure 15. (HA-91)**

Yes

**CHECK INTAKE DOOR OPERATION.**  
 Set up "ACTIVE TEST" mode with CONSULT.  
 or  
 Set up Self-diagnosis STEP 4.  
 Does intake air change according to each mode?

 Set mode	REC	20% FRE	20% FRE	80% FRE	FRE	FRE
 Code No.	41	42	43	44	45	46
Air intake	REC	20% FRE	20% FRE	80% FRE	FRE	

No →

**CHECK INTAKE DOOR ROD or LEVER MECHANISM.**  
 Refer to Control Linkage Adjustment. (HA-103)

NG →

**Repair or adjust.**

OK

↓

**Go to Diagnostic Procedure 15. (HA-91)**

Yes

**Intake door control system is normal.**  
 Refer to **Intake door control specification.** (HA-118)

# TROUBLE DIAGNOSES

## Preliminary Check (Cont'd)

### PRELIMINARY CHECK 3

Insufficient cooling

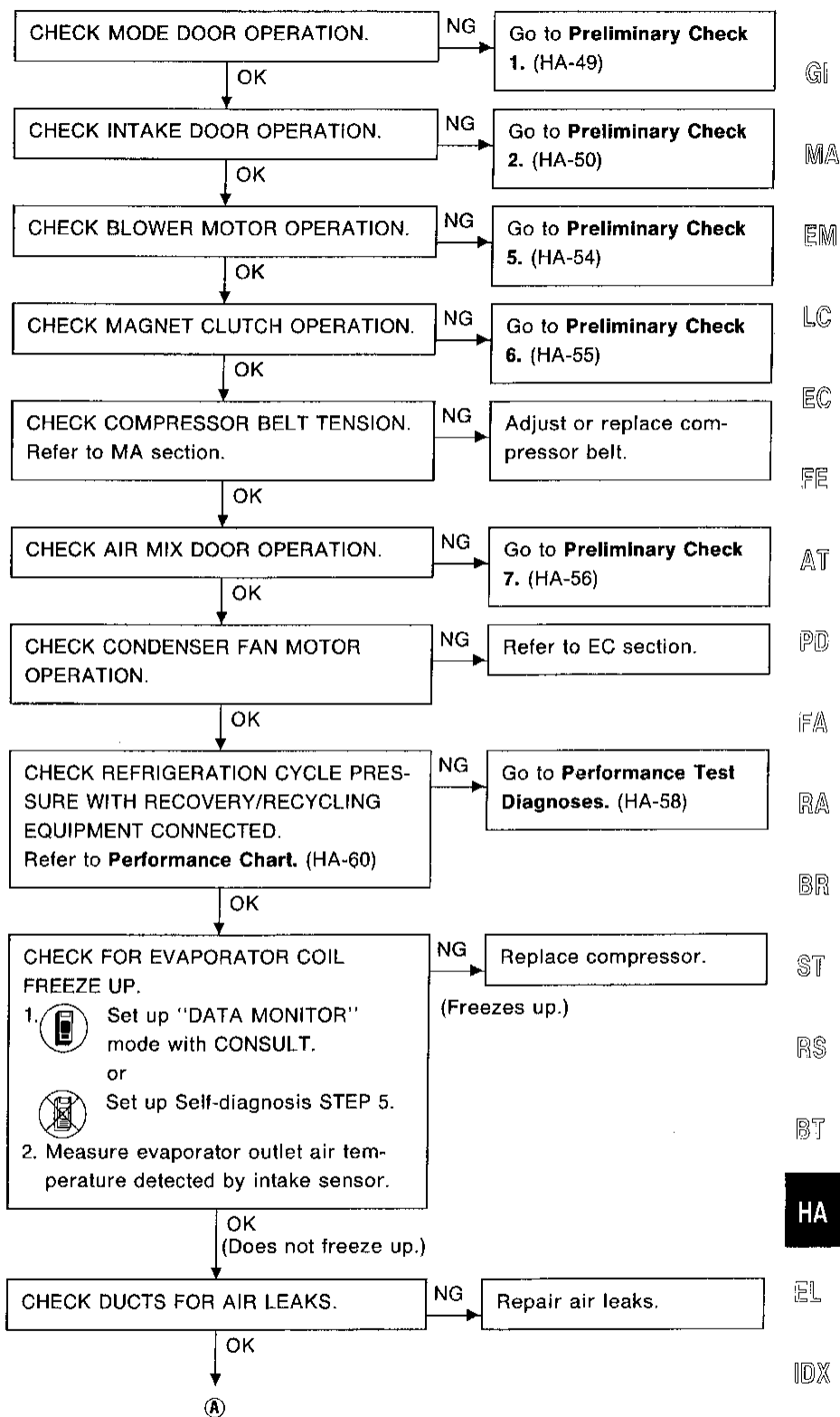

GI

MA

EM

LC

EC

FE

AT

PD

FA

RA

BR

ST

RS

BT

HA

EL





IDX

## TROUBLE DIAGNOSES

### Preliminary Check (Cont'd)

A

PERFORM TEMPERATURE SETTING TRIMMING.

-  Set up "WORK SUPPORT — temp. setting trimmer" mode with CONSULT.  
or  
 Set up AUXILIARY MECHANISM mode in Self-diagnosis.
-  Press DOWN switch repeatedly until desired temperature is reached.  
or  
 Turn temperature switch towards COLD for desired temperature.

# TROUBLE DIAGNOSES

## Preliminary Check (Cont'd)

### PRELIMINARY CHECK 4

Insufficient heating

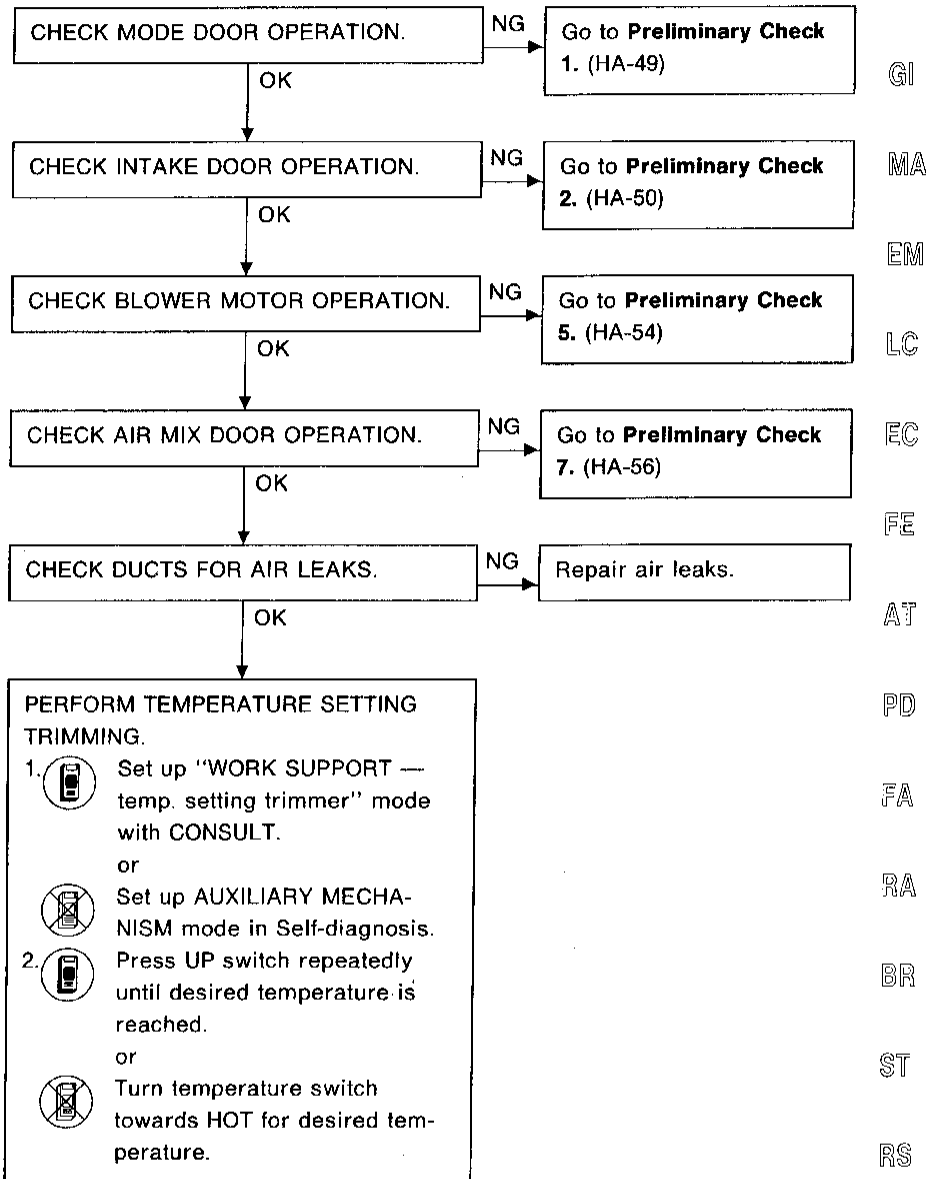

GI

MA

EM

LC

EC

FE

AT

PD

FA

RA

BR

ST

RS

BT

**HA**

EL

IDX

# TROUBLE DIAGNOSES

## Preliminary Check (Cont'd)

### PRELIMINARY CHECK 5

**Blower motor operation is malfunctioning.**

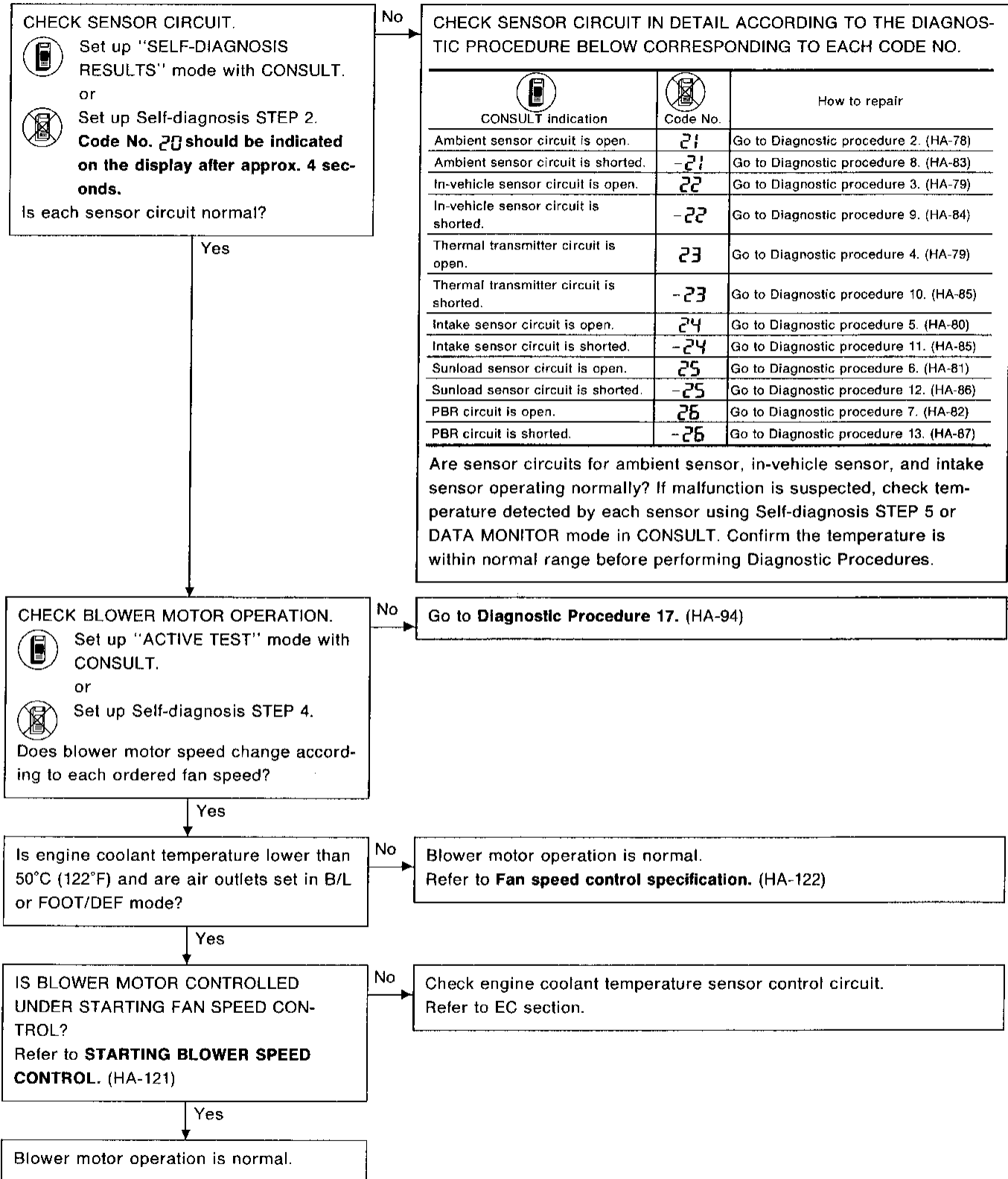



# TROUBLE DIAGNOSES

## Preliminary Check (Cont'd)

### PRELIMINARY CHECK 6

**Magnet clutch does not engage.**

**CHECK SENSOR CIRCUIT.**



-  Set up "SELF-DIAGNOSIS RESULTS" mode with CONSULT.
- or
-  Set up Self-diagnosis STEP 2.

**Code No. 20 should be indicated on the display after approx. 4 seconds.**

Is each sensor circuit normal?



No

**CHECK SENSOR CIRCUIT IN DETAIL ACCORDING TO THE DIAGNOSTIC PROCEDURE BELOW CORRESPONDING TO EACH CODE NO.**



 CONSULT indication	 Code No.	How to repair
Ambient sensor circuit is open.	21	Go to Diagnostic procedure 2. (HA-78)
Ambient sensor circuit is shorted.	-21	Go to Diagnostic procedure 8. (HA-83)
In-vehicle sensor circuit is open.	22	Go to Diagnostic procedure 3. (HA-79)
In-vehicle sensor circuit is shorted.	-22	Go to Diagnostic procedure 9. (HA-84)
Thermal transmitter circuit is open.	23	Go to Diagnostic procedure 4. (HA-79)
Thermal transmitter circuit is shorted.	-23	Go to Diagnostic procedure 10. (HA-85)
Intake sensor circuit is open.	24	Go to Diagnostic procedure 5. (HA-80)
Intake sensor circuit is shorted.	-24	Go to Diagnostic procedure 11. (HA-85)
Sunload sensor circuit is open.	25	Go to Diagnostic procedure 6. (HA-81)
Sunload sensor circuit is shorted.	-25	Go to Diagnostic procedure 12. (HA-86)
PBR circuit is open.	26	Go to Diagnostic procedure 7. (HA-82)
PBR circuit is shorted.	-26	Go to Diagnostic procedure 13. (HA-87)

Are sensor circuits for ambient sensor, in-vehicle sensor, and intake sensor operating normally? If malfunction is suspected, check temperature detected by each sensor using Self-diagnosis STEP 5 or DATA MONITOR mode in CONSULT. Confirm the temperature is within normal range before performing Diagnostic Procedures.

**CHECK MAGNET CLUTCH OPERATION.**

-  Set up "ACTIVE TEST" mode with CONSULT.
- or
-  Set up Self-diagnosis STEP 4.

Check if magnet clutch engages according to order from CONSULT or each code No.

 Set mode	ON	ON	OFF	OFF	ON	ON
 Code No.	41	42	43	44	45	46
Magnet clutch operation	ON	ON	OFF	OFF	ON	ON

NG

**CHECK REFRIGERANT.**  
Connect recovery/recycling equipment then check system pressure.

NG

OK

Go to **Performance Test Diagnoses.** (HA-58)

Go to **Diagnostic Procedure 18.** (HA-97)

OK

Magnet clutch control system is normal.  
Refer to **MAGNET CLUTCH CONTROL.** (HA-123)

GI  
MA  
EM  
LC  
EC  
FE  
AT  
PD  
FA  
RA  
BR  
ST  
RS  
BT  
HA  
EL  
IDX

# TROUBLE DIAGNOSES

## Preliminary Check (Cont'd)

### PRELIMINARY CHECK 7

Discharged air temperature does not change.

**CHECK SENSOR CIRCUIT.**



 Set up "SELF-DIAGNOSIS RESULTS" mode with CONSULT. or

 Set up Self-diagnosis STEP 2. **Code No. 20 should be indicated on the display after approx. 4 seconds.**

Is each sensor circuit normal?

No

**CHECK SENSOR CIRCUIT IN DETAIL ACCORDING TO THE DIAGNOSTIC PROCEDURE BELOW CORRESPONDING TO EACH CODE NO.**

 CONSULT indication	 Code No.	How to repair
Ambient sensor circuit is open.	21	Go to Diagnostic procedure 2. (HA-78)
Ambient sensor circuit is shorted.	-21	Go to Diagnostic procedure 8. (HA-83)
In-vehicle sensor circuit is open.	22	Go to Diagnostic procedure 3. (HA-79)
In-vehicle sensor circuit is shorted.	-22	Go to Diagnostic procedure 9. (HA-84)
Thermal transmitter circuit is open.	23	Go to Diagnostic procedure 4. (HA-79)
Thermal transmitter circuit is shorted.	-23	Go to Diagnostic procedure 10. (HA-85)
Intake sensor circuit is open.	24	Go to Diagnostic procedure 5. (HA-80)
Intake sensor circuit is shorted.	-24	Go to Diagnostic procedure 11. (HA-85)
Sunload sensor circuit is open.	25	Go to Diagnostic procedure 6. (HA-81)
Sunload sensor circuit is shorted.	-25	Go to Diagnostic procedure 12. (HA-86)
PBR circuit is open.	26	Go to Diagnostic procedure 7. (HA-82)
PBR circuit is shorted.	-26	Go to Diagnostic procedure 13. (HA-87)

Are sensor circuits for ambient sensor, in-vehicle sensor, and intake sensor operating normally? If malfunction is suspected, check temperature detected by each sensor using Self-diagnosis STEP 5 or DATA MONITOR mode in CONSULT. Confirm the temperature is within normal range before performing Diagnostic Procedures.



Yes

**CHECK AIR MIX DOOR OPERATION.**

 Set up "ACTIVE TEST" mode with CONSULT. or

 Set up Self-diagnosis STEP 4.

Check if discharge air temperature changes as shown in the following chart.

 Set mode	Full cold	Full cold	Full hot	Full hot	Full hot	Full hot
 Code No.	41	42	43	44	45	46
Discharge air temperature	Full cold	Full cold	Full hot	Full hot	Full hot	Full hot

NG

**CHECK AIR MIX DOOR MECHANISM.**  
Refer to Control Linkage Adjustment. (HA-102)

NG

Repair or adjust.

OK

Go to Diagnostic Procedure 16. (HA-93)

OK

Air mix door control system is normal. Refer to **Air mix door control specification.** (HA-111)



# TROUBLE DIAGNOSES

## Preliminary Check (Cont'd)

### PRELIMINARY CHECK 8

#### Noise

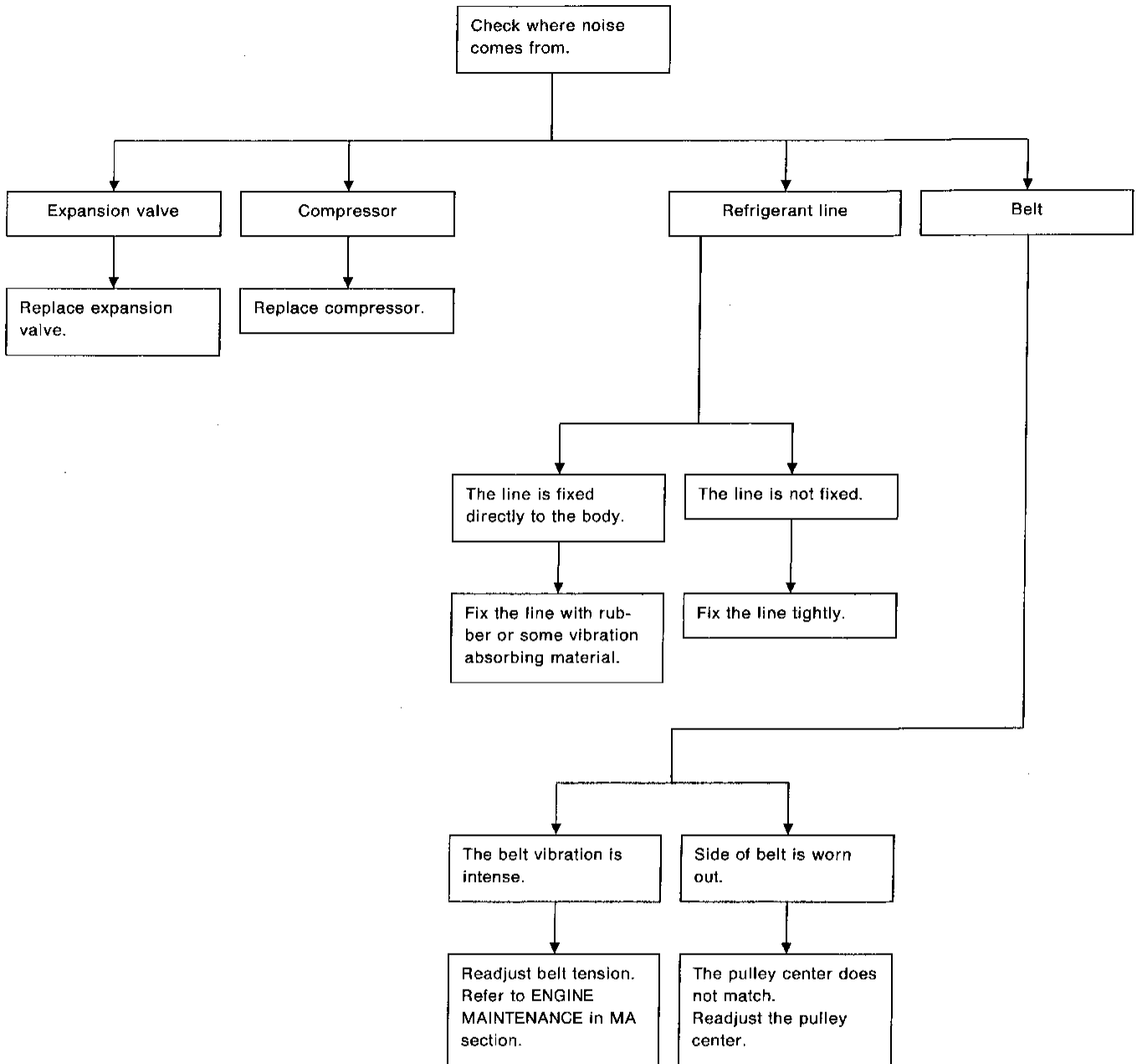

GI

MA

EM

LC

EC

FE

AT

PD

FA

RA

BR

ST

RS

BT

HA

EL

IDX

# TROUBLE DIAGNOSES

## Performance Test Diagnoses INSUFFICIENT COOLING

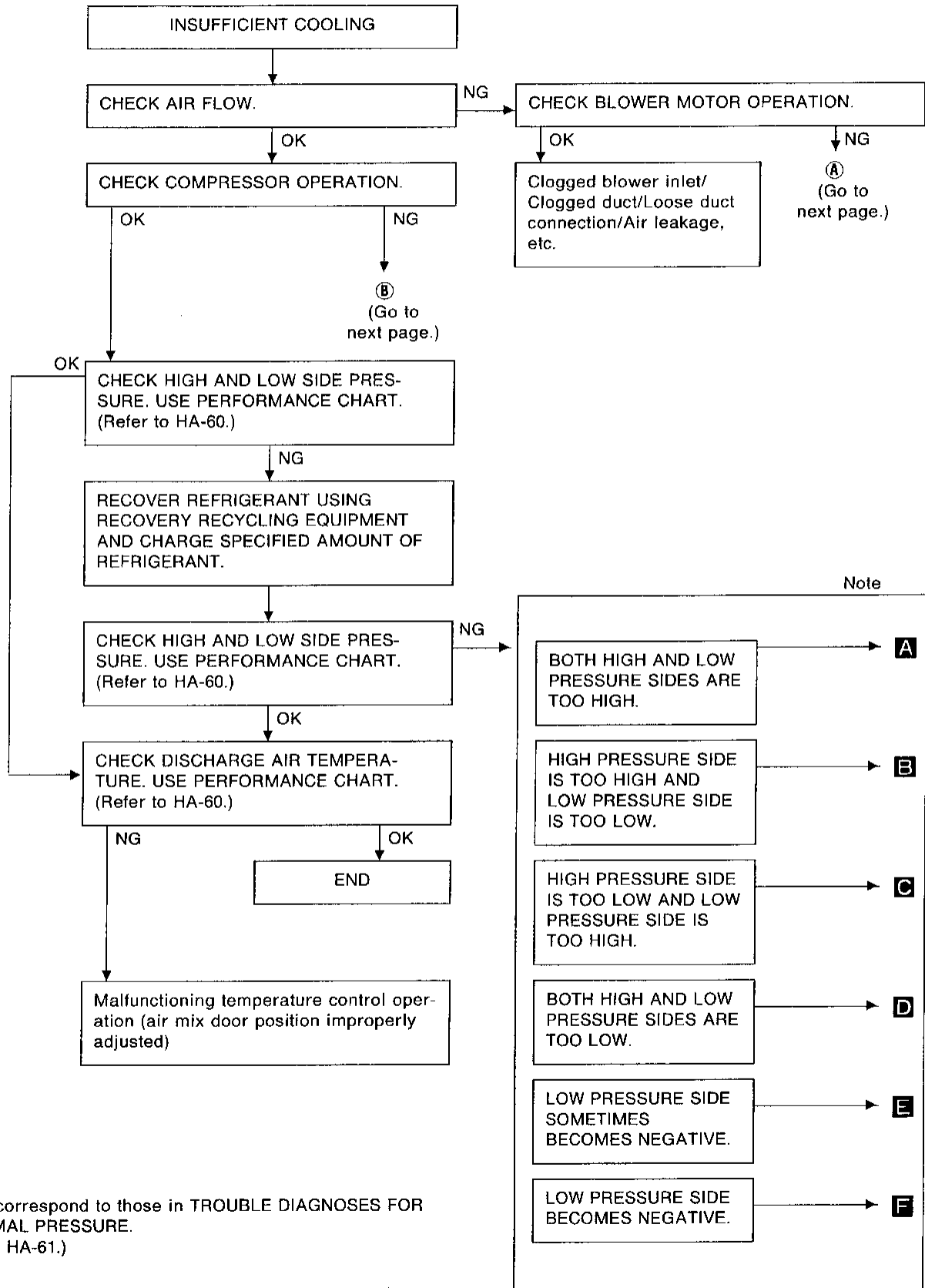

Note: **A-F** correspond to those in TROUBLE DIAGNOSES FOR ABNORMAL PRESSURE. (Refer to HA-61.)

# TROUBLE DIAGNOSES

## Performance Test Diagnoses (Cont'd)

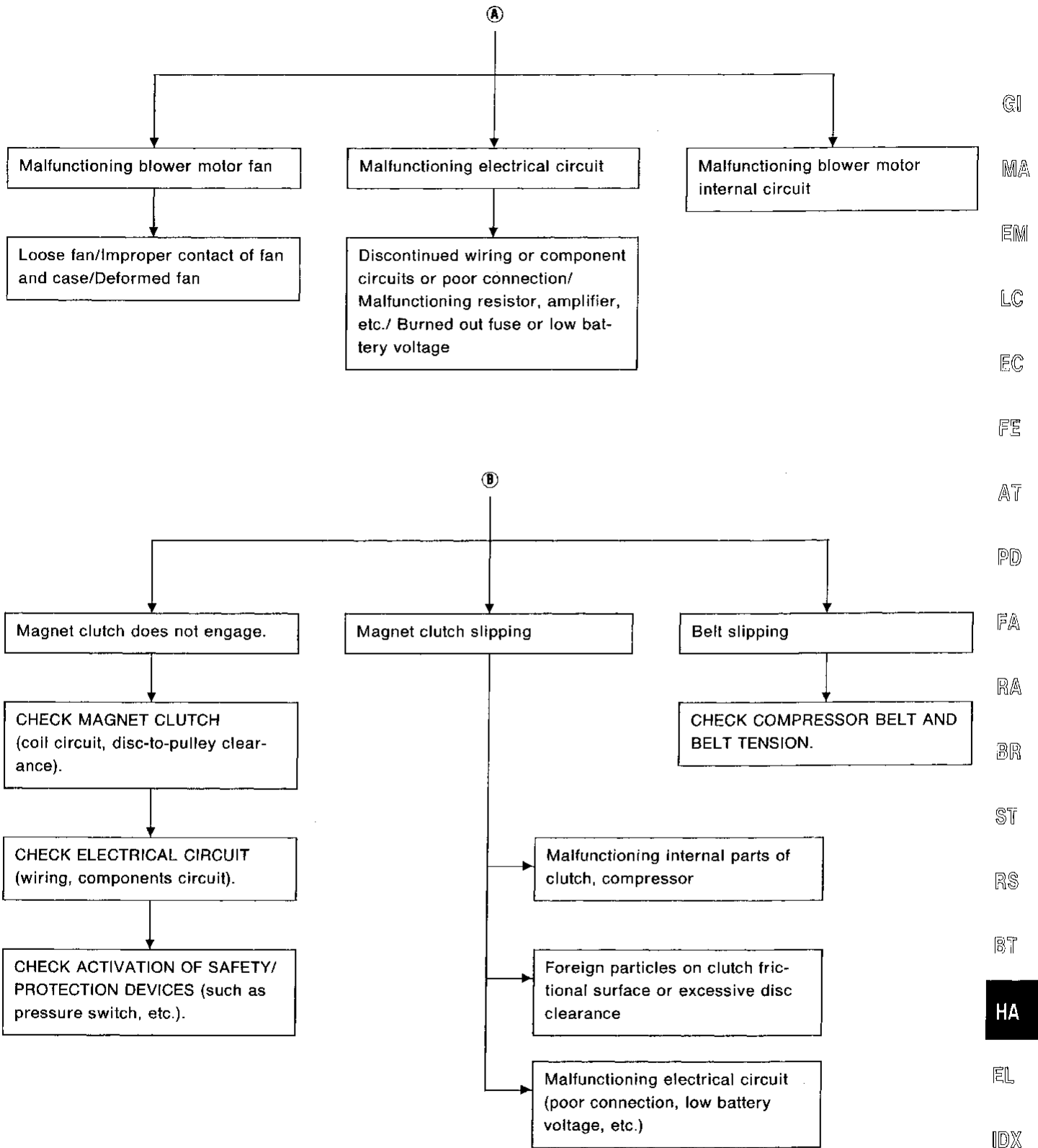

CI  
MA  
EM  
LC  
EC  
FE  
AT  
PD  
FA  
RA  
BR  
ST  
RS  
BT  
HA  
EL  
IDX

# TROUBLE DIAGNOSES

## Performance Chart

### TEST CONDITION

**Before conducting performance test, disconnect ambient sensor harness connector and make short circuit using jumper cable.**

Testing must be performed as follows:

Vehicle location: Indoors or in the shade (in a well ventilated place)

Doors: Closed

Door window: Open

Hood: Open

AUTO switch: ON

Temperature switch (PTC): Max. COLD set

Mode switch:  (Ventilation) set

 (RECIRCULATION) switch:  (Recirculation) set

Blower switch: Max. speed set

Engine speed: 1,500 rpm

Operate the air conditioning system for 10 minutes before taking measurements.

### TEST READING

#### Recirculating-to-discharge air temperature table

Inside air (Recirculating air) at blower assembly inlet		Discharge air temperature at center ventilator °C (°F)
Relative humidity %	Air temperature °C (°F)	
50 - 60	20 (68)	1.7 - 2.5 (35 - 37)
	25 (77)	4.3 - 5.3 (40 - 42)
	30 (86)	8.4 - 10.2 (47 - 50)
	35 (95)	13.0 - 15.3 (55 - 60)
60 - 70	20 (68)	2.5 - 3.7 (37 - 39)
	25 (77)	5.3 - 7.0 (42 - 45)
	30 (86)	10.2 - 12.0 (50 - 54)
	35 (95)	15.3 - 18.5 (60 - 65)

#### Ambient air temperature-to-operating pressure table

Ambient air		High-pressure (Discharge side) kPa (kg/cm <sup>2</sup> , psi)	Low-pressure (Suction side) kPa (kg/cm <sup>2</sup> , psi)
Relative humidity %	Air temperature °C (°F)		
50 - 70	20 (68)	843 - 1,030 (8.6 - 10.5, 122 - 149)	147 - 177 (1.5 - 1.8, 21 - 26)
	25 (77)	1,040 - 1,275 (10.6 - 13.0, 151 - 185)	147 - 186 (1.5 - 1.9, 21 - 27)
	30 (86)	1,255 - 1,540 (12.8 - 15.7, 182 - 223)	157 - 196 (1.6 - 2.0, 23 - 28)
	35 (95)	1,500 - 1,824 (15.3 - 18.6, 218 - 264)	167 - 216 (1.7 - 2.2, 24 - 31)
	40 (104)	1,746 - 2,128 (17.8 - 21.7, 253 - 309)	196 - 265 (2.0 - 2.7, 28 - 38)

# TROUBLE DIAGNOSES

## Trouble Diagnoses for Abnormal Pressure

Whenever system's high and/or low side pressure is abnormal, diagnose using a manifold gauge. The marker above the gauge scale in the following tables indicates the standard (normal) pressure range. Since the standard (normal) pressure, however, differs from vehicle to vehicle, refer to HA-60 ("Ambient air temperature-to-operating pressure table").

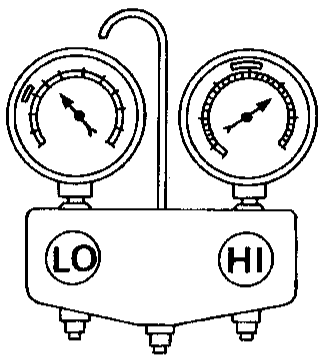
Gauge indication	Refrigerant cycle	Probable cause	Corrective action
<p>Both high and low-pressure sides are too high.</p> <p><b>A</b></p>  <p style="text-align: right;">AC359A</p>	<ul style="list-style-type: none"> <li>Pressure is reduced soon after water is splashed on condenser.</li> </ul>	Excessive refrigerant charge in refrigeration cycle	Reduce refrigerant until specified pressure is obtained.
	<p>Air suction by cooling fan is insufficient.</p>	<p>Insufficient condenser cooling performance</p> <p style="text-align: center;">↓</p> <ul style="list-style-type: none"> <li>① Condenser fins are clogged.</li> <li>② Improper fan rotation of cooling fan</li> </ul>	<ul style="list-style-type: none"> <li>Clean condenser.</li> <li>Check and repair cooling fan as necessary.</li> </ul>
	<ul style="list-style-type: none"> <li>Low-pressure pipe is not cold.</li> <li>When compressor is stopped high-pressure value quickly drops by approximately 196 kPa (2 kg/cm<sup>2</sup>, 28 psi). It then decreases gradually thereafter.</li> </ul>	<p>Poor heat exchange in condenser (After compressor operation stops, high pressure decreases too slowly.)</p> <p style="text-align: center;">↓</p> <p>Air in refrigeration cycle</p>	Evacuate repeatedly and recharge system.
	Engine tends to overheat.	Engine cooling systems malfunction.	Check and repair each engine cooling system.
	<ul style="list-style-type: none"> <li>An area of the low-pressure pipe is colder than near the evaporator outlet.</li> <li>Plates are sometimes covered with frost.</li> </ul>	<ul style="list-style-type: none"> <li>Excessive liquid refrigerant on low-pressure side</li> <li>Excessive refrigerant discharge flow</li> <li>Expansion valve is open a little compared with the specification.</li> </ul> <p style="text-align: center;">↓</p> <ul style="list-style-type: none"> <li>① Improper thermal valve installation</li> <li>② Improper expansion valve adjustment</li> </ul>	Replace expansion valve.

GI

MA

EM

LC

EC

FE

AT

PD

FA

RA

BR

ST

RS

BT

HA

EL

IDX

## TROUBLE DIAGNOSES

### Trouble Diagnoses for Abnormal Pressure (Cont'd)

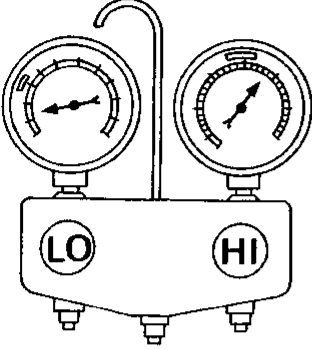
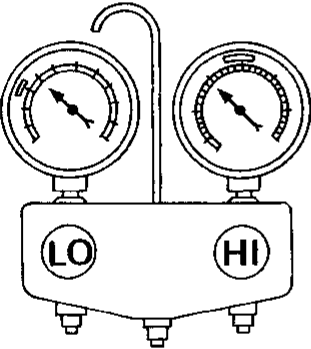
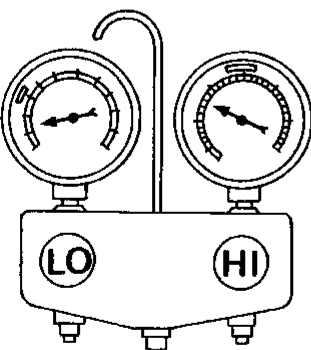
Gauge indication	Refrigerant cycle	Probable cause	Corrective action
<p>High-pressure side is too high and low-pressure side is too low.</p> <p><b>B</b></p>  <p style="text-align: center;">AC360A</p>	<p>Upper side of condenser and high-pressure side are hot, however, liquid tank is not so hot.</p>	<p>High-pressure tube or parts located between compressor and condenser are clogged or crushed.</p>	<ul style="list-style-type: none"> <li>● Check and repair or replace malfunctioning parts.</li> <li>● Check lubricant for contamination.</li> </ul>
<p>High-pressure side is too low and low-pressure side is too high.</p> <p><b>C</b></p>  <p style="text-align: center;">AC356A</p>	<p>High and low-pressure sides become equal soon after compressor operation stops.</p>	<p>Compressor pressure operation is improper.</p> <p style="text-align: center;">↓</p> <p>Damaged inside compressor packings</p>	<p>Replace compressor.</p>
	<p>No temperature difference between high and low-pressure sides</p>	<p>Compressor discharge capacity does not change. (Compressor stroke is set at maximum.)</p>	<p>Replace compressor.</p>
<p>Both high- and low-pressure sides are too low.</p> <p><b>D</b></p>  <p style="text-align: center;">AC353A</p>	<ul style="list-style-type: none"> <li>● There is a big temperature difference between liquid tank outlet and inlet. Outlet temperature is extremely low.</li> <li>● Liquid tank inlet and expansion valve are frosted.</li> </ul>	<p>Liquid tank inside is clogged a little.</p>	<ul style="list-style-type: none"> <li>● Replace liquid tank.</li> <li>● Check lubricant for contamination.</li> </ul>
	<ul style="list-style-type: none"> <li>● Temperature of expansion valve inlet is extremely low as compared with areas near liquid tank.</li> <li>● Expansion valve inlet may be frosted.</li> <li>● Temperature difference occurs somewhere in high-pressure side</li> </ul>	<p>High-pressure pipe located between liquid tank and expansion valve is clogged.</p>	<ul style="list-style-type: none"> <li>● Check and repair malfunctioning parts.</li> <li>● Check lubricant for contamination.</li> </ul>
	<ul style="list-style-type: none"> <li>● Expansion valve and liquid tank are warm or only cool when touched.</li> </ul>	<p>Low refrigerant charge</p> <p style="text-align: center;">↓</p> <p>Leaking fittings or components</p>	<p>Check refrigerant for leaks. Refer to "Checking Refrigerant Leaks", HA-130.</p>

# TROUBLE DIAGNOSES

## Trouble Diagnoses for Abnormal Pressure (Cont'd)

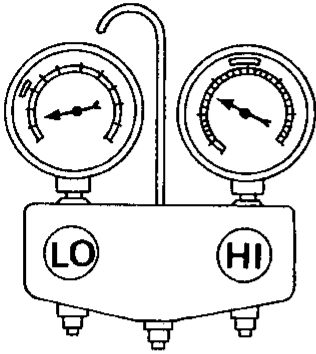
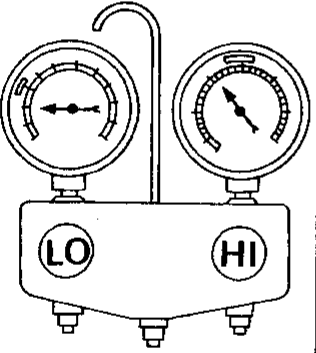
Gauge indication	Refrigerant cycle	Probable cause	Corrective action
<p>Both high- and low-pressure sides are too low.</p> <p><b>D</b></p>  <p style="text-align: right;">AC353A</p>	<p>There is a big temperature difference between expansion valve inlet and outlet while the valve itself is frosted.</p>	<p>Expansion valve closes a little compared with the specification.</p> <p style="text-align: center;">↓</p> <p>① Improper expansion valve adjustment ② Malfunctioning thermal valve ③ Outlet and inlet may be clogged.</p>	<ul style="list-style-type: none"> <li>● Remove foreign particles by using compressed air.</li> <li>● Check lubricant for contamination.</li> </ul>
	<p>An area of the low-pressure pipe is colder than near the evaporator outlet.</p>	<p>Low-pressure pipe is clogged or crushed.</p>	<ul style="list-style-type: none"> <li>● Check and repair malfunctioning parts.</li> <li>● Check lubricant for contamination.</li> </ul>
	<p>Air flow volume is not enough or is too low.</p>	<p>Evaporator is frozen.</p> <p style="text-align: center;">↓</p> <p>Compressor discharge capacity does not change. (Compressor stroke is set at maximum length.)</p>	<p>Replace compressor.</p>
<p>Low-pressure side sometimes becomes negative.</p> <p><b>E</b></p>  <p style="text-align: right;">AC354A</p>	<ul style="list-style-type: none"> <li>● Air conditioning system does not function and does not cyclically cool the compartment air.</li> <li>● The system constantly functions for a certain period of time after compressor is stopped and restarted.</li> </ul>	<p>Refrigerant does not discharge cyclically.</p> <p style="text-align: center;">↓</p> <p>Moisture is frozen at expansion valve outlet and inlet.</p> <p style="text-align: center;">↓</p> <p>Water is mixed with refrigerant.</p>	<ul style="list-style-type: none"> <li>● Drain water from refrigerant or replace refrigerant.</li> <li>● Replace liquid tank.</li> </ul>

GI

MA

EM

LC

EC

FE

AY

PD

FA

RA

BR

ST

RS

BT

HA

EL

IDX

## TROUBLE DIAGNOSES

### Trouble Diagnoses for Abnormal Pressure (Cont'd)

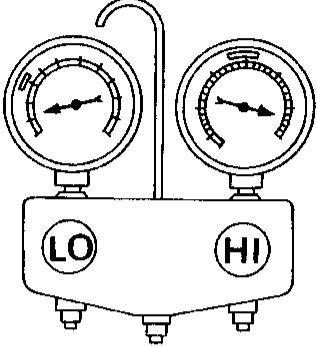
Gauge indication	Refrigerant cycle	Probable cause	Corrective action
<p>Low-pressure side becomes negative.</p> <p><b>F</b></p>  <p style="text-align: right;">AC362A</p>	<p>Liquid tank or front/rear side of expansion valve's pipe is frosted or dewed.</p>	<p>High-pressure side is closed and refrigerant does not flow.</p> <p style="text-align: center;">↓</p> <p>Expansion valve or liquid tank is frosted.</p>	<p>Leave the system at rest until no frost is present. Start it again to check whether or not the problem is caused by water or foreign particles.</p> <ul style="list-style-type: none"> <li>● If water is the cause, initially cooling is okay. Then the water freezes, causing a blockage. Drain water from refrigerant or replace refrigerant.</li> <li>● If due to foreign particles, remove expansion valve and remove the particles with dry and compressed air (not shop air).</li> <li>● If either of the above methods cannot correct the problem, replace expansion valve.</li> <li>● Replace liquid tank.</li> <li>● Check lubricant for contamination.</li> </ul>



A/C Component Layout

ENGINE COMPARTMENT

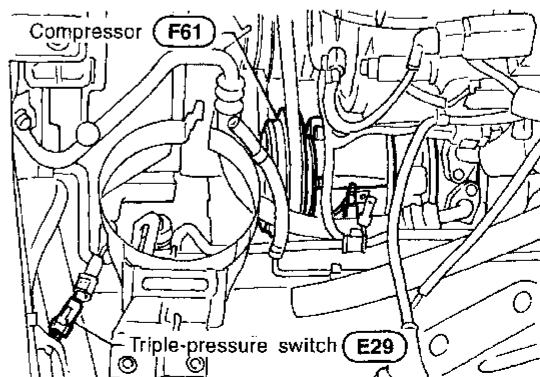
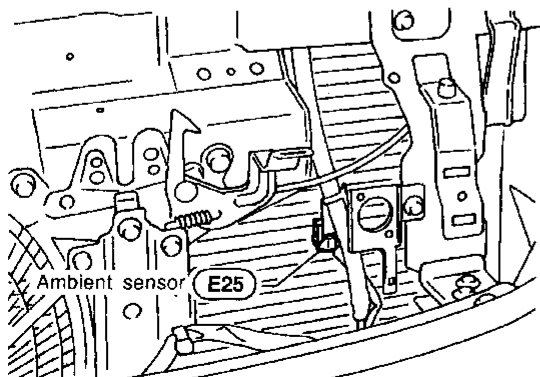
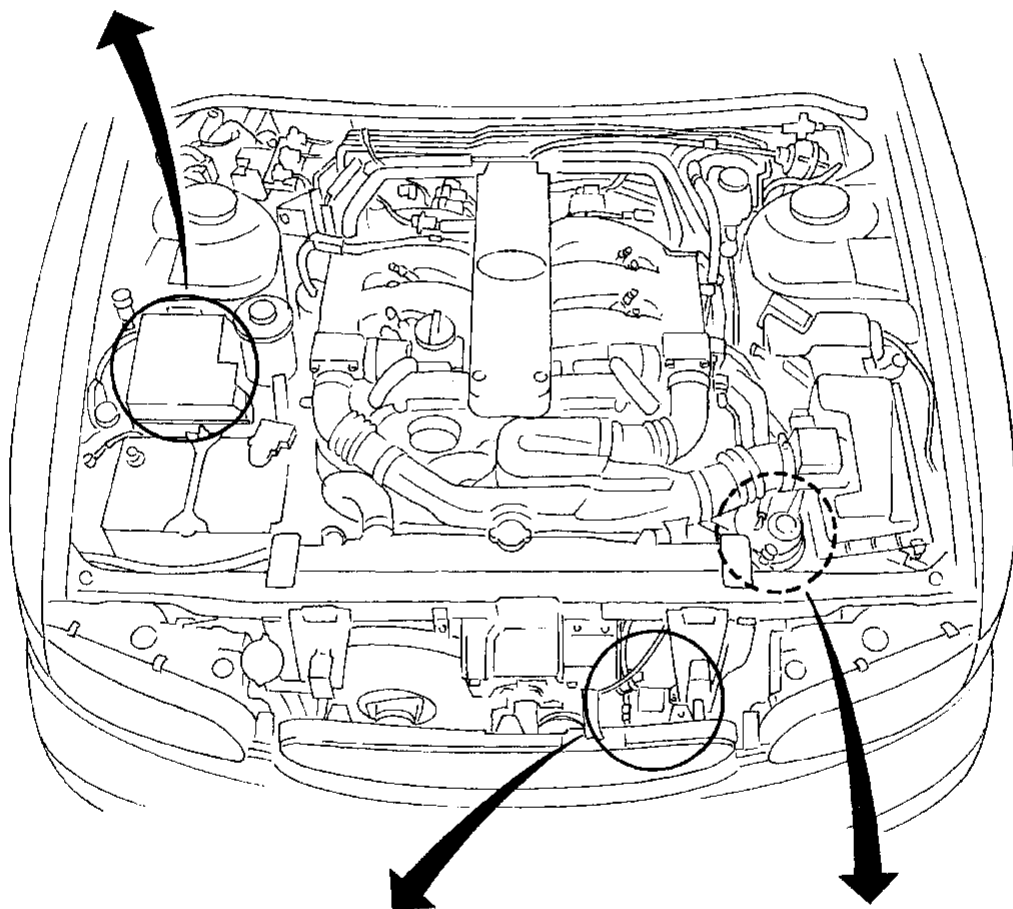
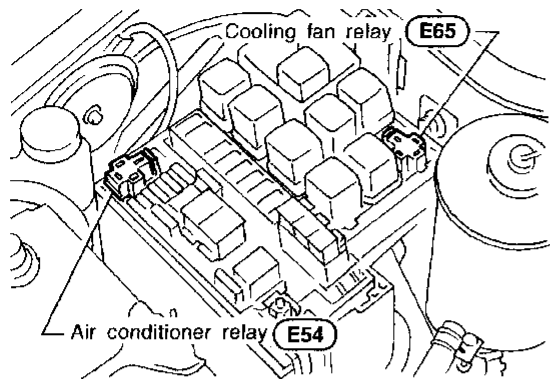

GI

MA

EM

LC

EC

FE

AT

PD

FA

RA

BR

ST

RS

BT

HA

EL

IDX

# TROUBLE DIAGNOSES

## A/C Component Layout (Cont'd)

### PASSENGER COMPARTMENT

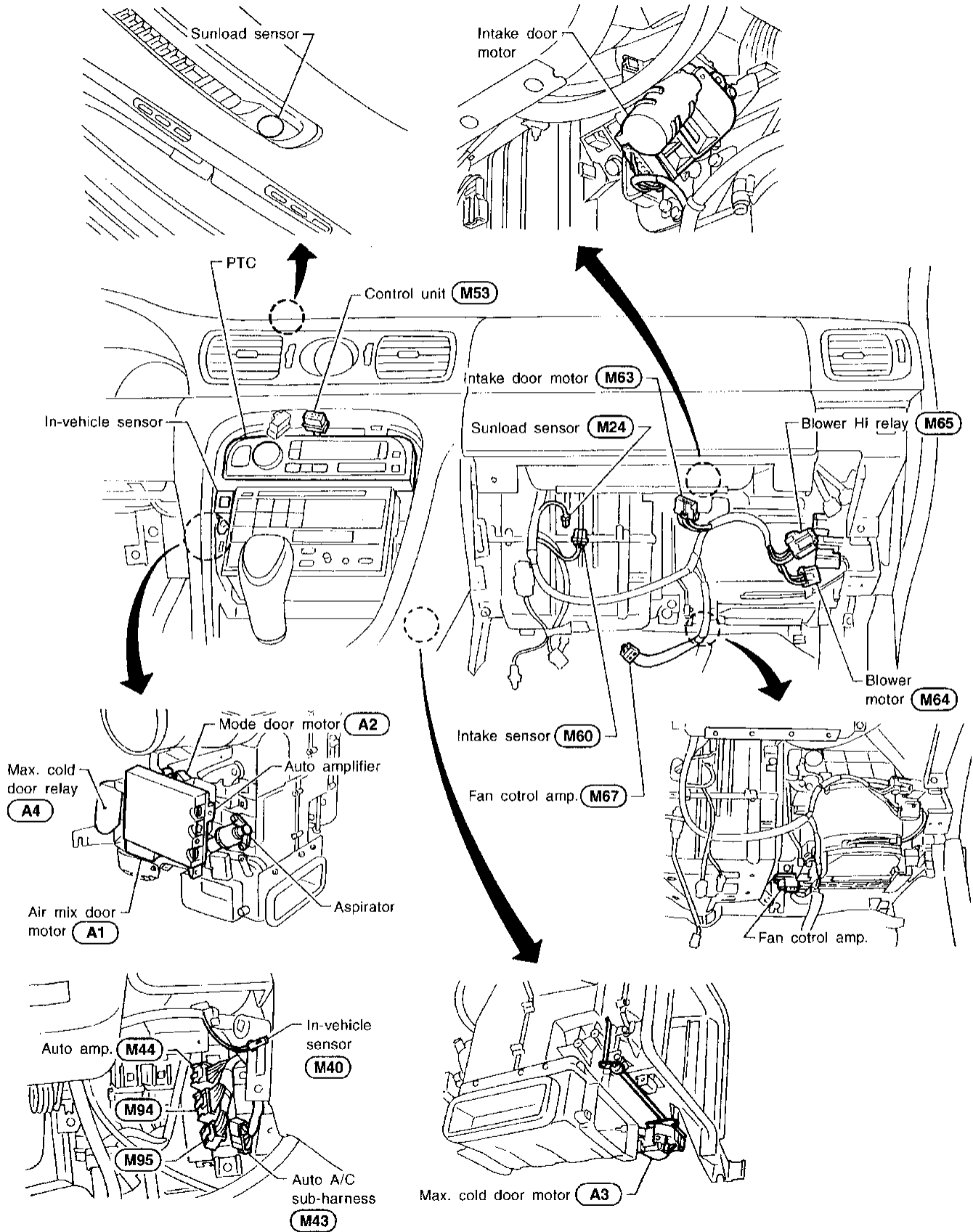

Circuit Diagram

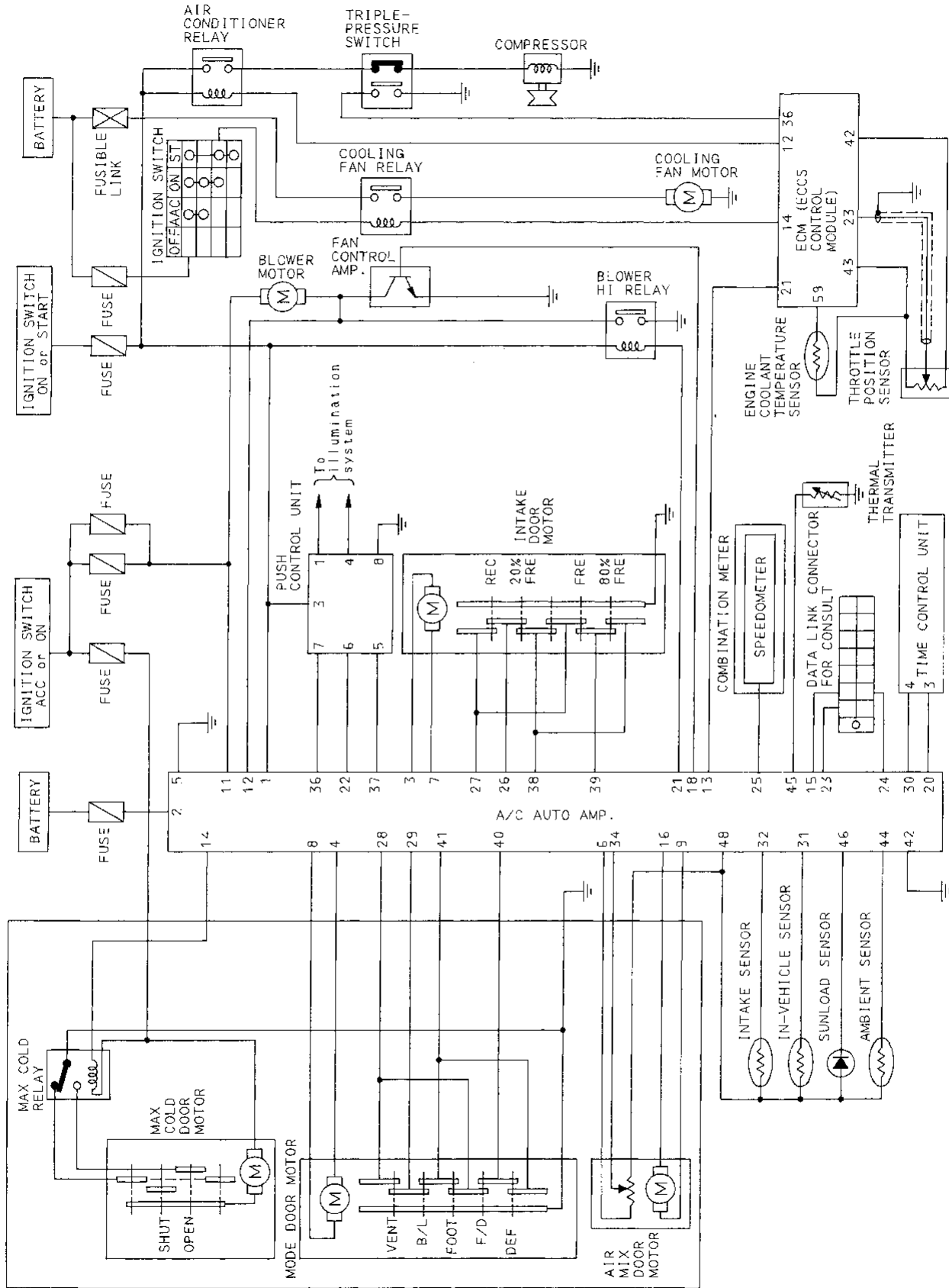

GI  
MA  
EM  
LC  
EC  
FE  
AT  
PD  
FA  
RA  
BR  
ST  
RS  
BT  
HA  
EL  
DX

# TROUBLE DIAGNOSES

## Wiring Diagram — A/C —

HA-A/C-01

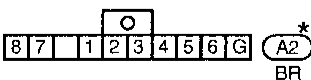
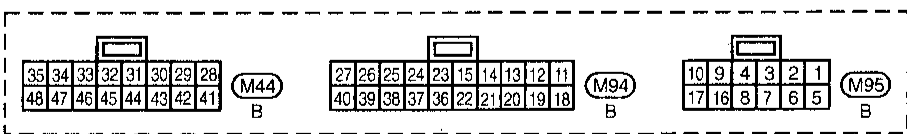
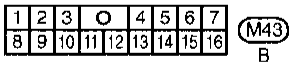
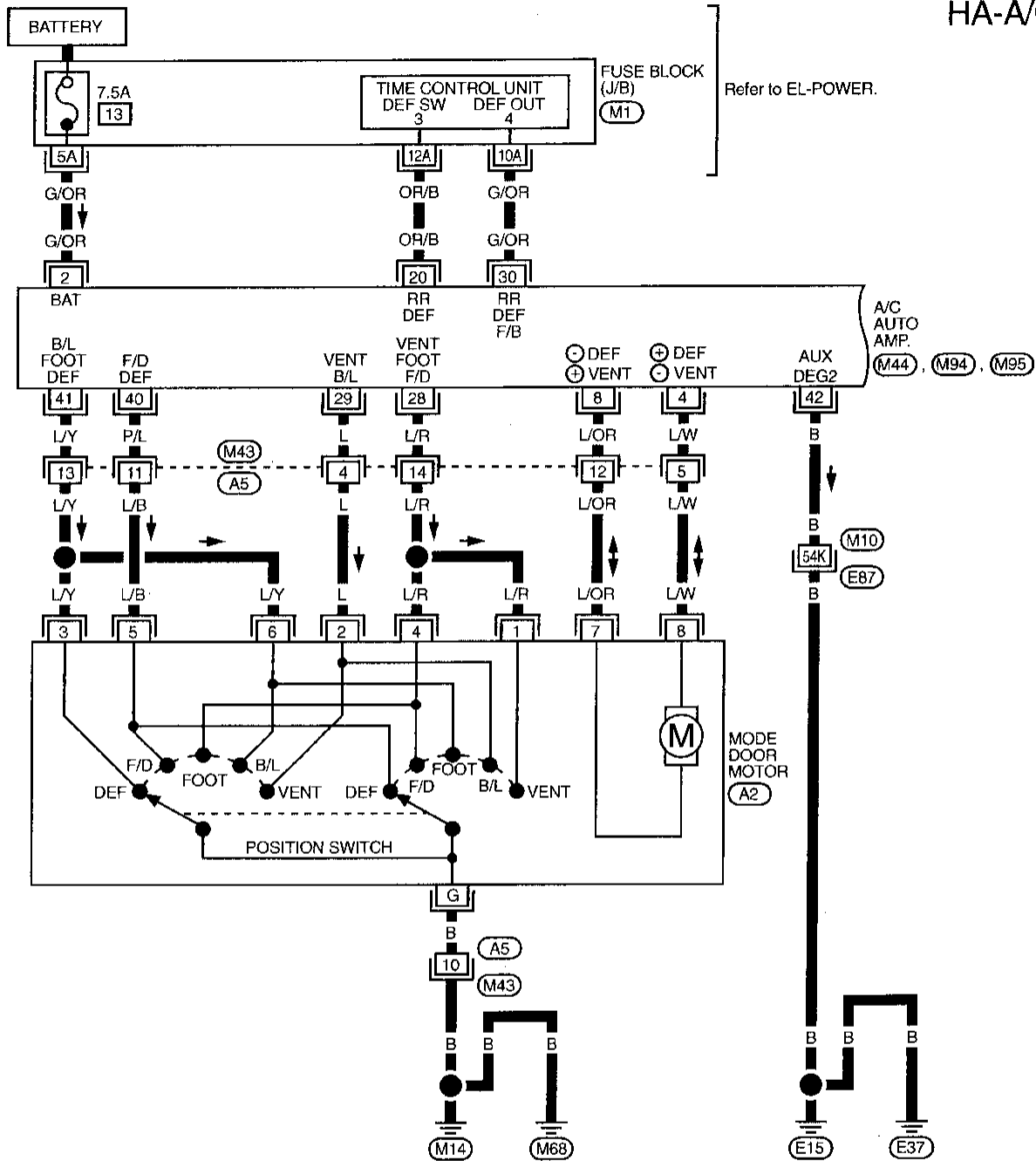

\* : This connector is not shown in "HARNESS LAYOUT" EL section.

Refer to last page (Foldout page).

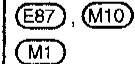

# TROUBLE DIAGNOSES

## Wiring Diagram — A/C — (Cont'd)

HA-A/C-02

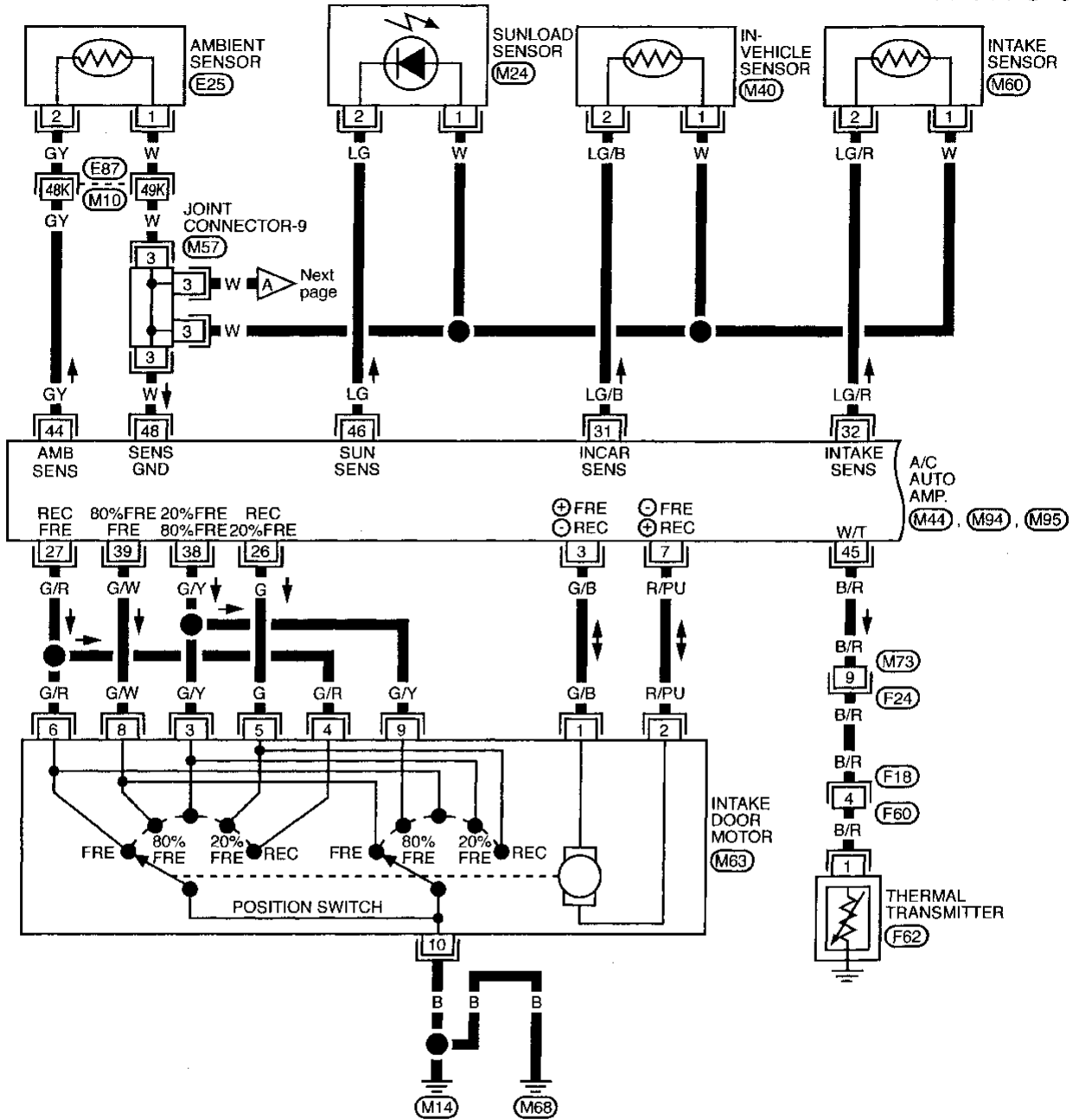

GI  
MA  
EM  
LC  
EC  
FE  
AT  
PD  
FA  
RA  
BR  
ST  
RS  
BT

HA

EL  
IDX

Refer to last page (Foldout page).  
E87, M10

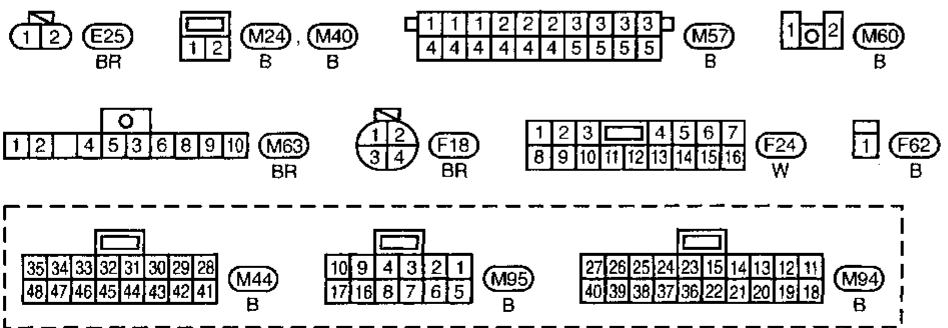

# TROUBLE DIAGNOSES

## Wiring Diagram — A/C — (Cont'd)

HA-A/C-03

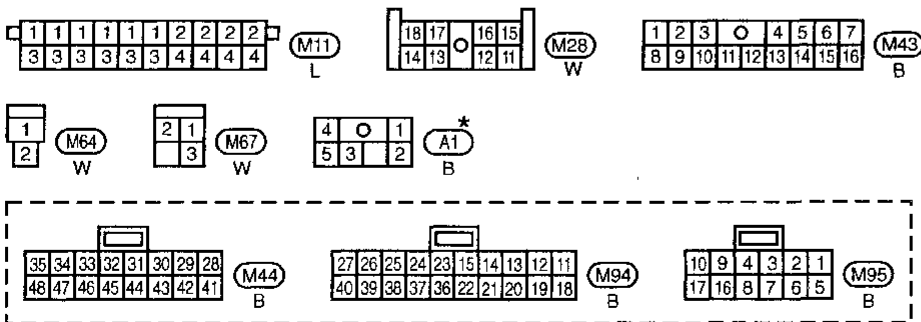
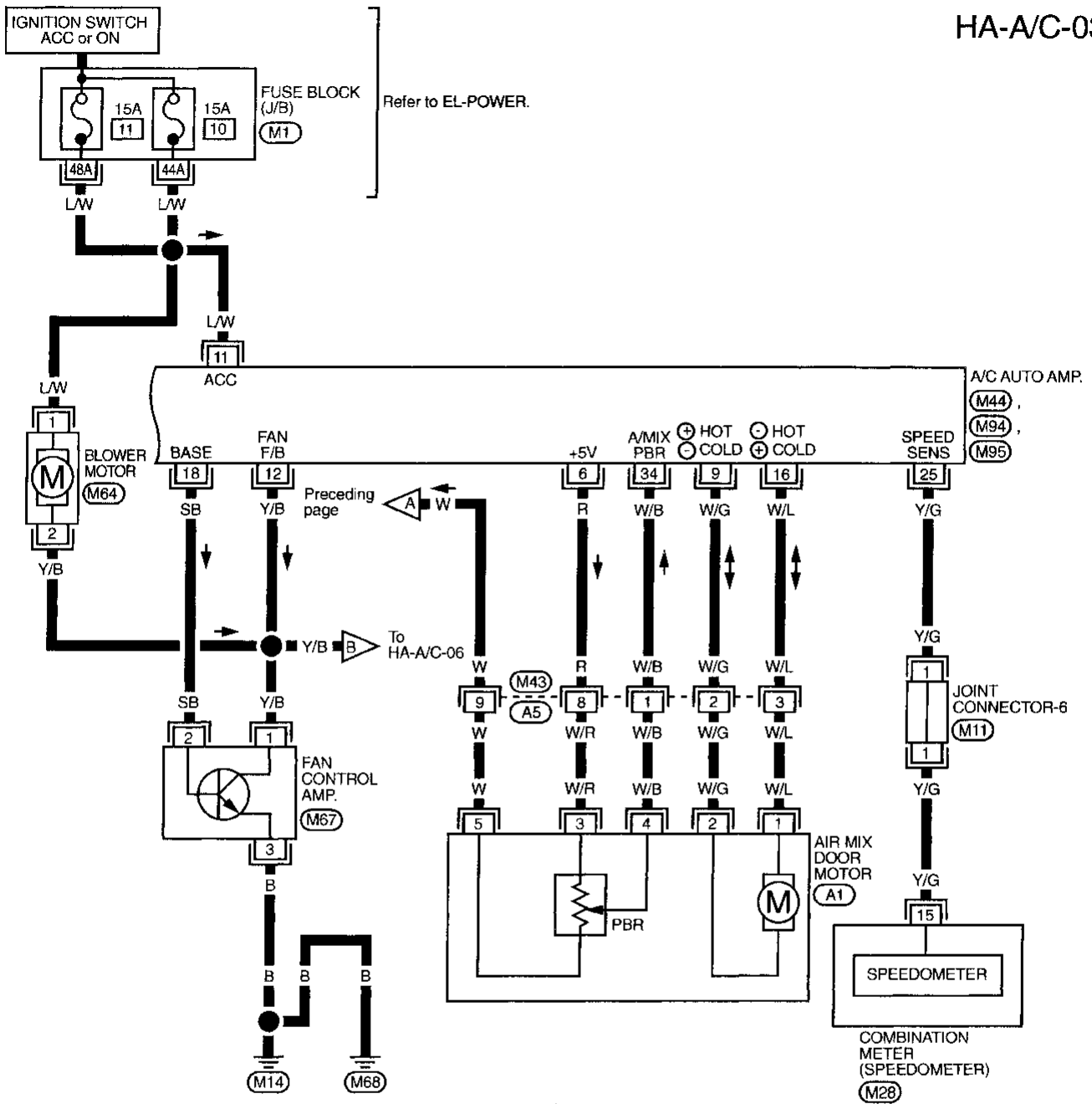

Refer to last page (Foldout page).

(M1)

\*: This connector is not shown in "HARNESS LAYOUT" EL section.



# TROUBLE DIAGNOSES

## Wiring Diagram — A/C — (Cont'd)

HA-A/C-05

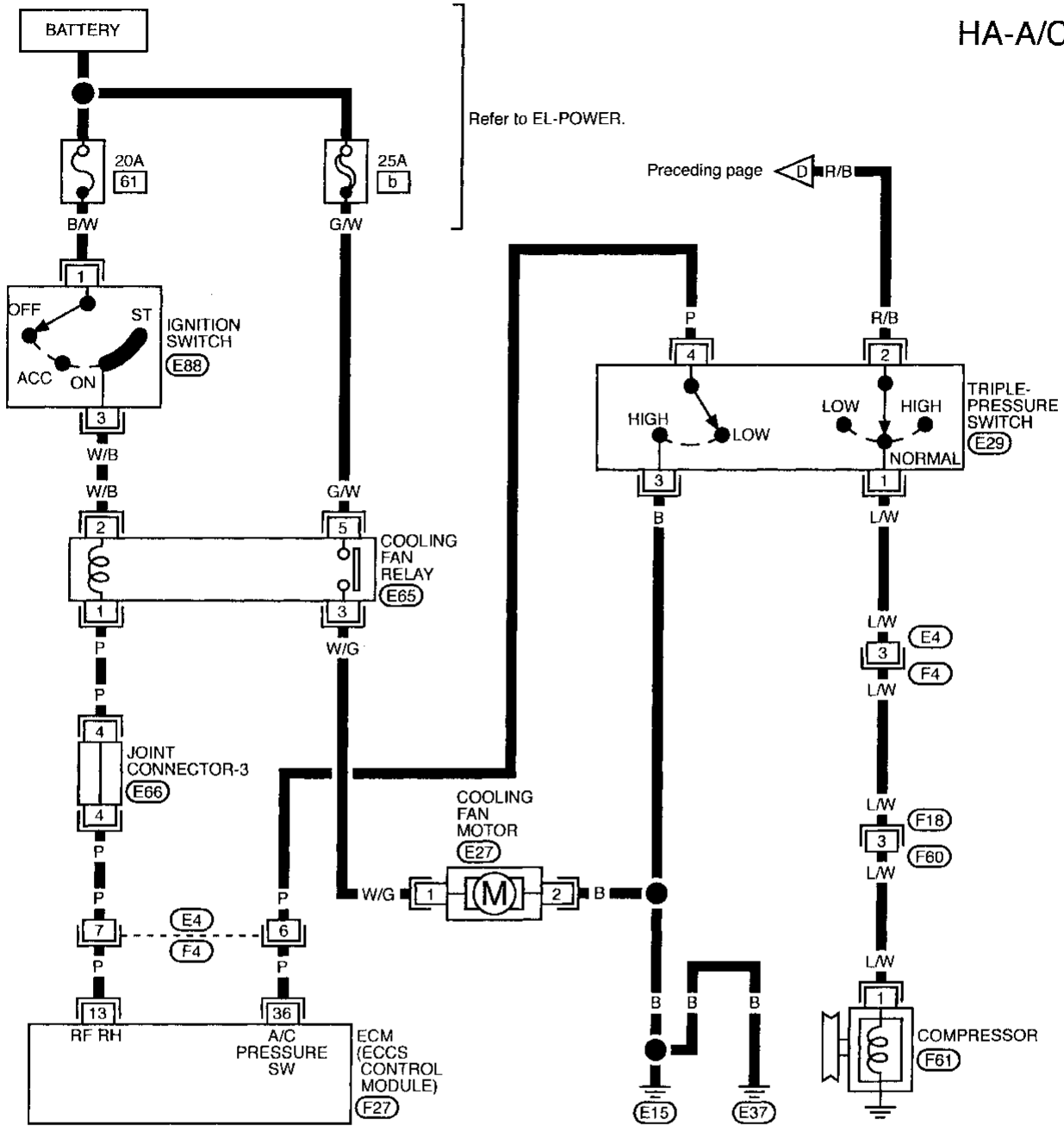

Refer to EL-POWER.

Preceding page



R/B

Refer to last page (Foldout page).

(F27)

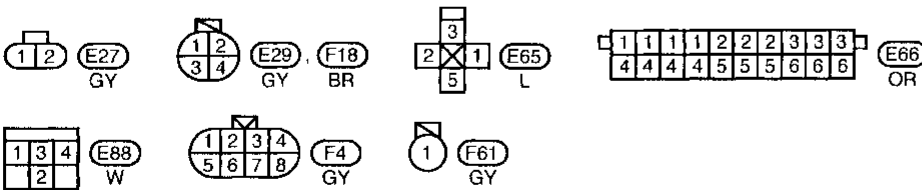



# TROUBLE DIAGNOSES

## Wiring Diagram — A/C — (Cont'd)

HA-A/C-06

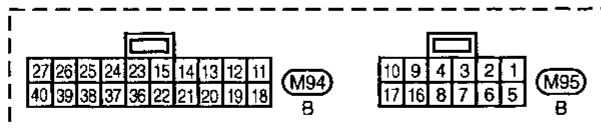
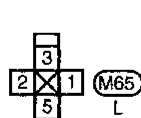
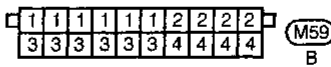
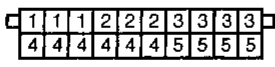
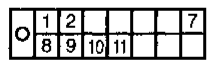
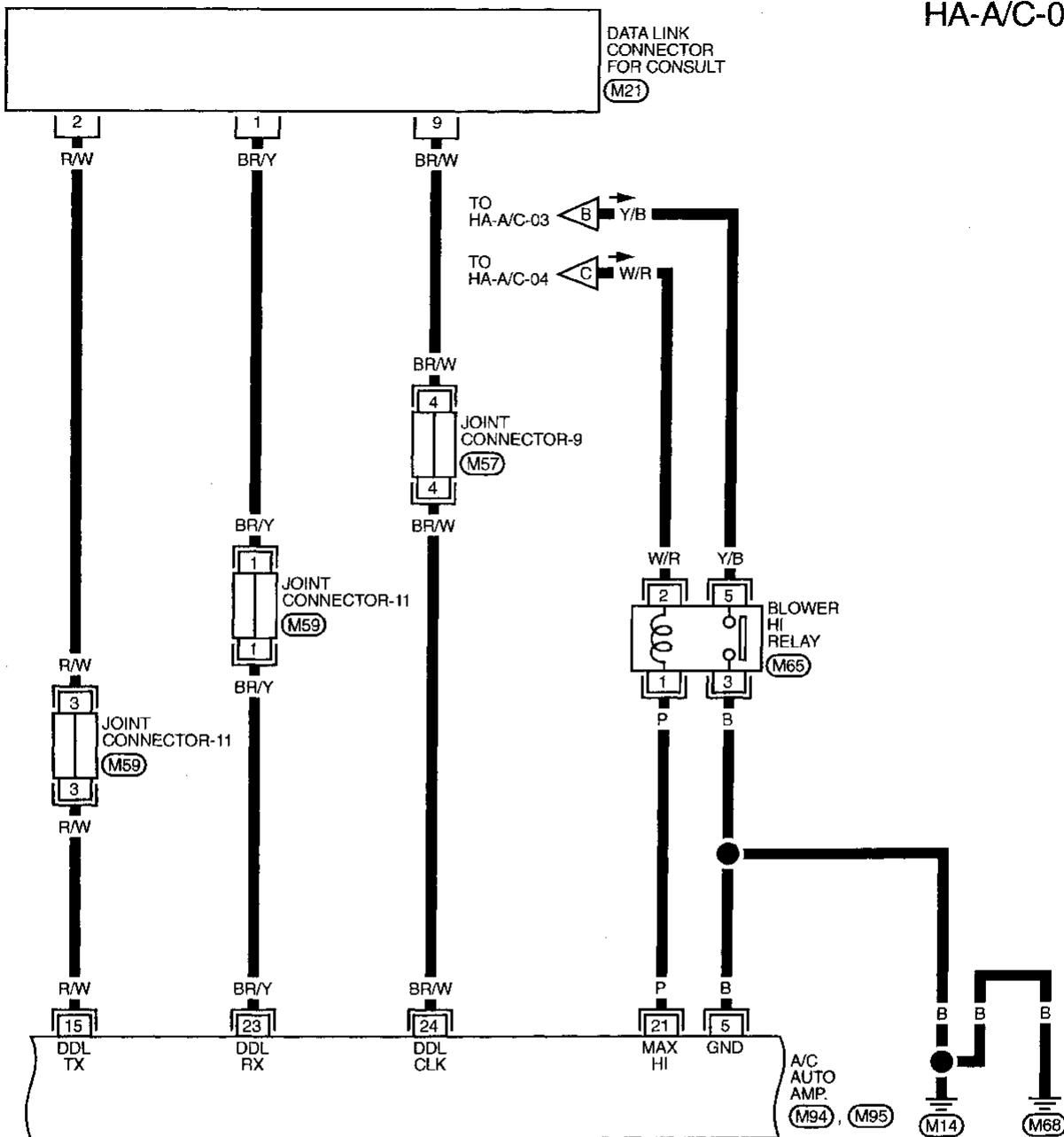

GI

MA

EM

LC

EC

FE

AT

PD

FA

RA

BR

ST

RS

BT

HA

EL

IDX

# TROUBLE DIAGNOSES

## Wiring Diagram — A/C — (Cont'd)

HA-A/C-07

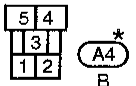
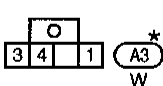
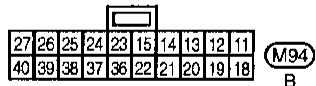
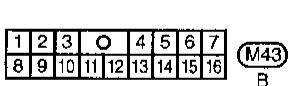
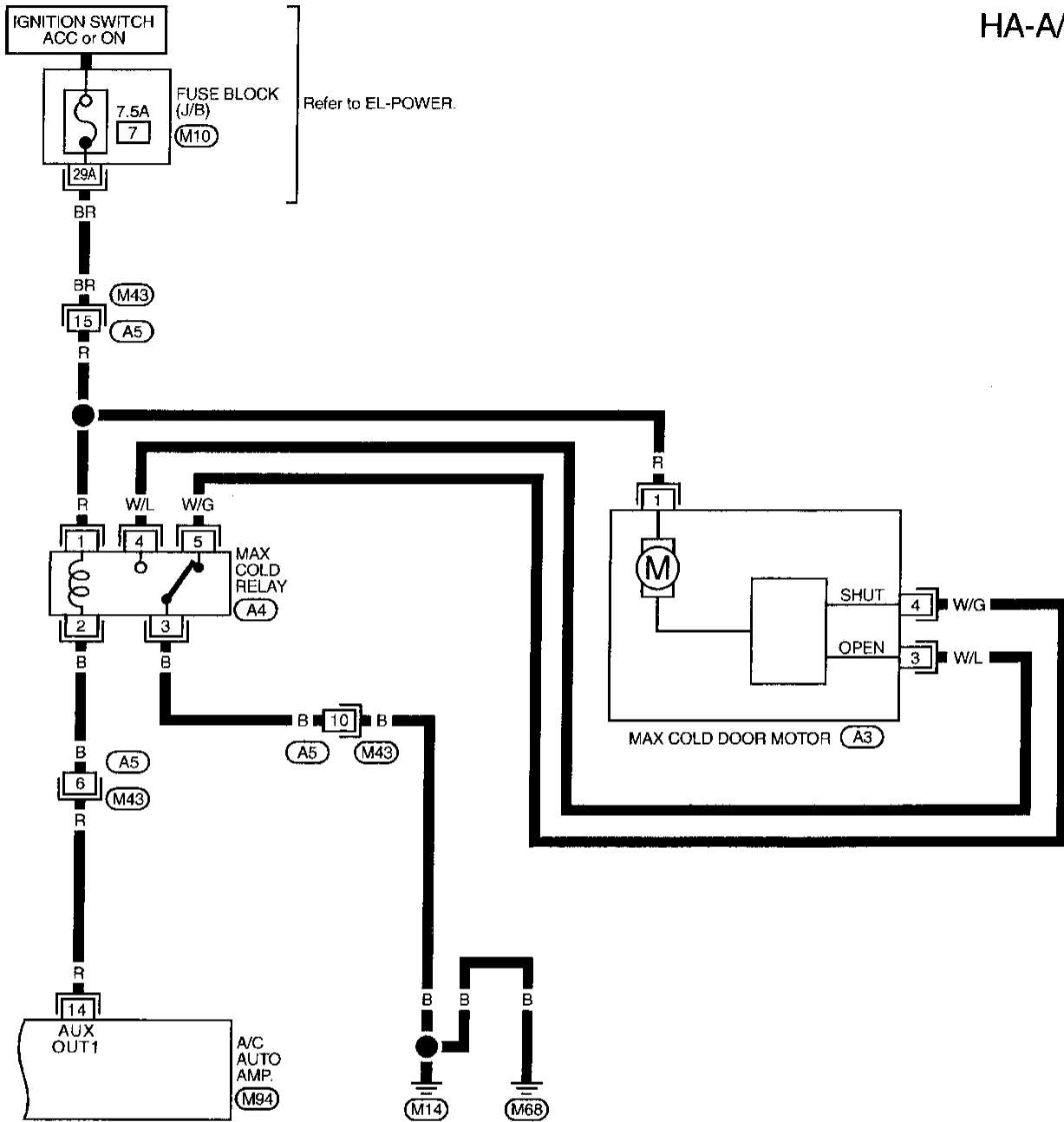

\* : This connector is not shown in "HARNESS LAYOUT" EL section.

Refer to last page (Foldout page).  
(M10)

# TROUBLE DIAGNOSES

## Wiring Diagram — A/C — (Cont'd)

HA-A/C-08

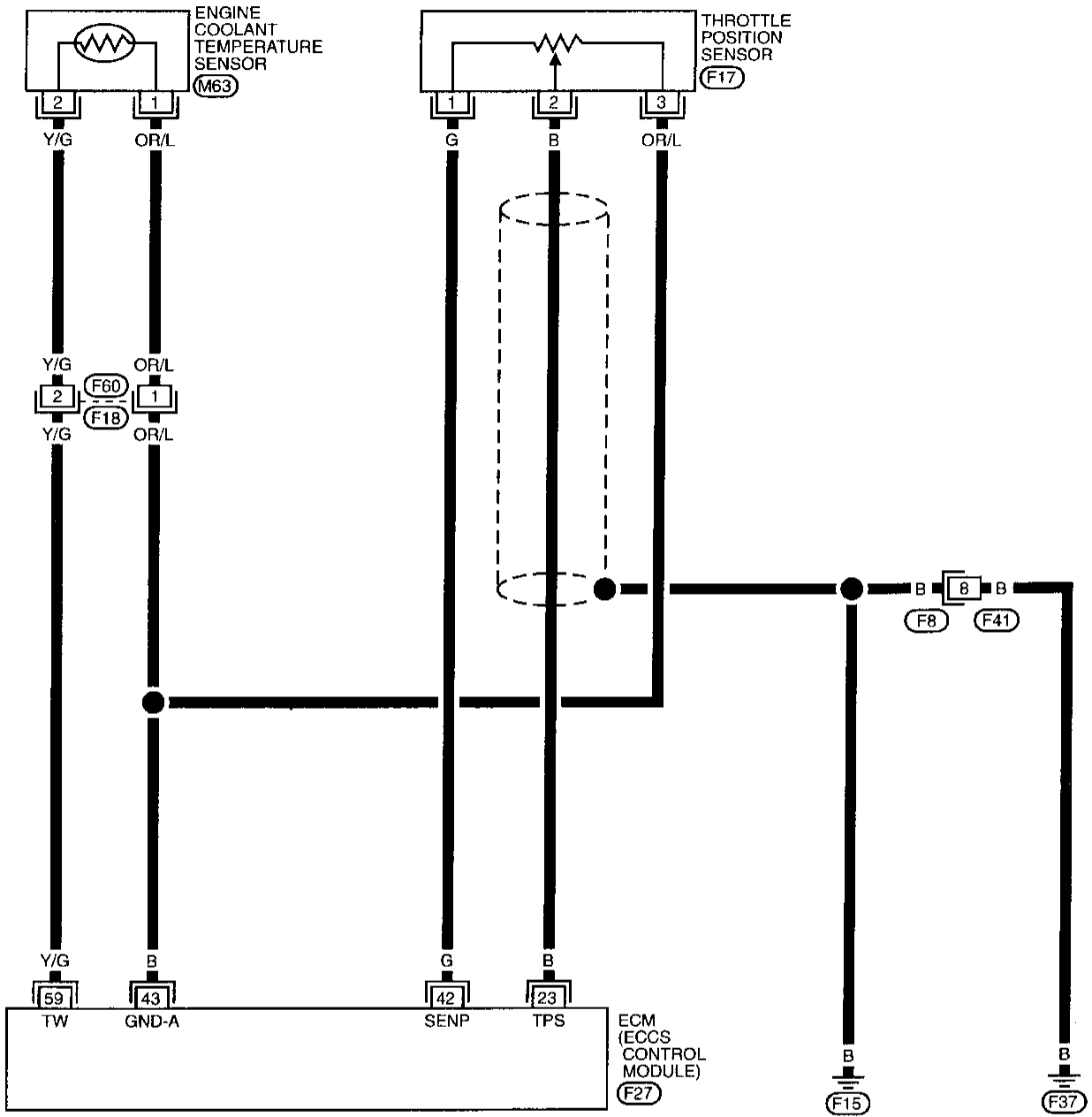

GI  
MA  
EM  
LC  
EC  
FE  
AT  
PD  
FA  
RA  
BR  
ST  
RS  
BT



Refer to last page (Foldout page).  
F27

HA  
EL  
IDX

# TROUBLE DIAGNOSES

## Main Power Supply and Ground Circuit Check POWER SUPPLY CIRCUIT CHECK FOR AUTO A/C SYSTEM

Check power supply circuit for auto air conditioning system.  
Refer to "POWER SUPPLY ROUTING" in EL section and Wiring Diagram.

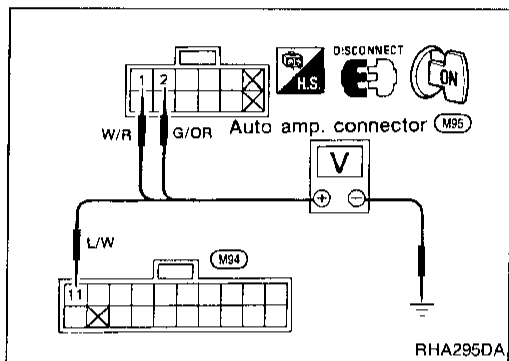

### AUTO AMP. CHECK

Check power supply circuit for auto amp. with ignition switch ON.  
Measure voltage across terminal No. ①, ②, ⑪ and body ground.

Voltmeter terminal		Voltage
⊕	⊖	
①	Body ground	Approx. 12V
②		
⑪		

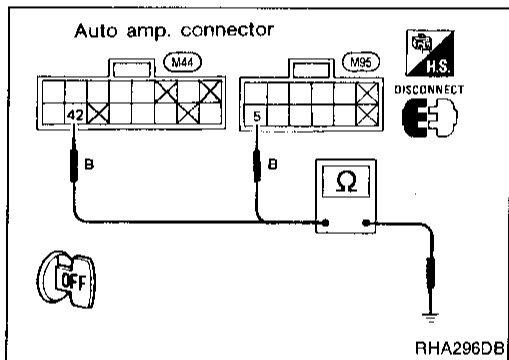

Check body ground circuit for auto amp. with ignition switch OFF.  
Check for continuity between terminal No. ⑤, ⑫ and body ground.

Ohmmeter terminal		Continuity
⊕	⊖	
⑤	Body ground	Yes
⑫		

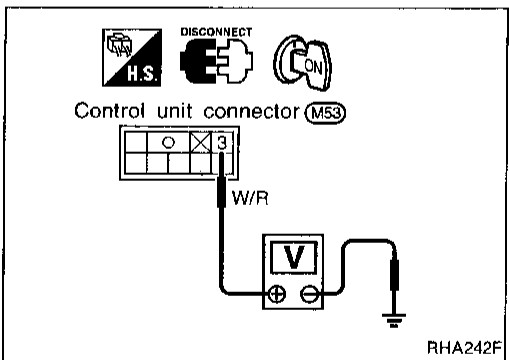

### CONTROL UNIT CHECK

Check power supply circuit for control unit with ignition switch ON.  
Measure voltage across terminal No. ③ and body ground.

Voltmeter terminal		Voltage
⊕	⊖	
③	Body ground	Approx. 12V

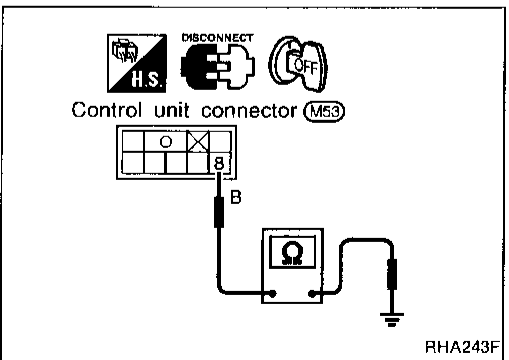

Check body ground circuit for control unit with ignition switch OFF.  
Check for continuity between terminal No. ⑧ and body ground.

Ohmmeter terminal		Continuity
⊕	⊖	
⑧	Body ground	Yes

# TROUBLE DIAGNOSES

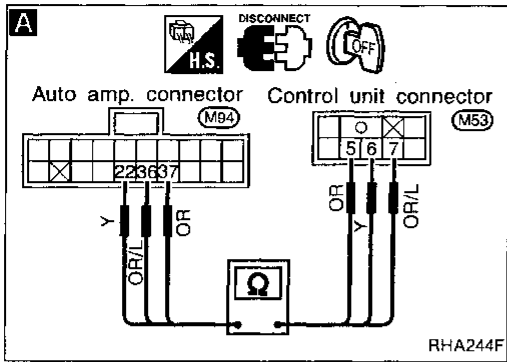

## Diagnostic Procedure 1

**SYMPTOM: Self-diagnosis cannot be performed.**

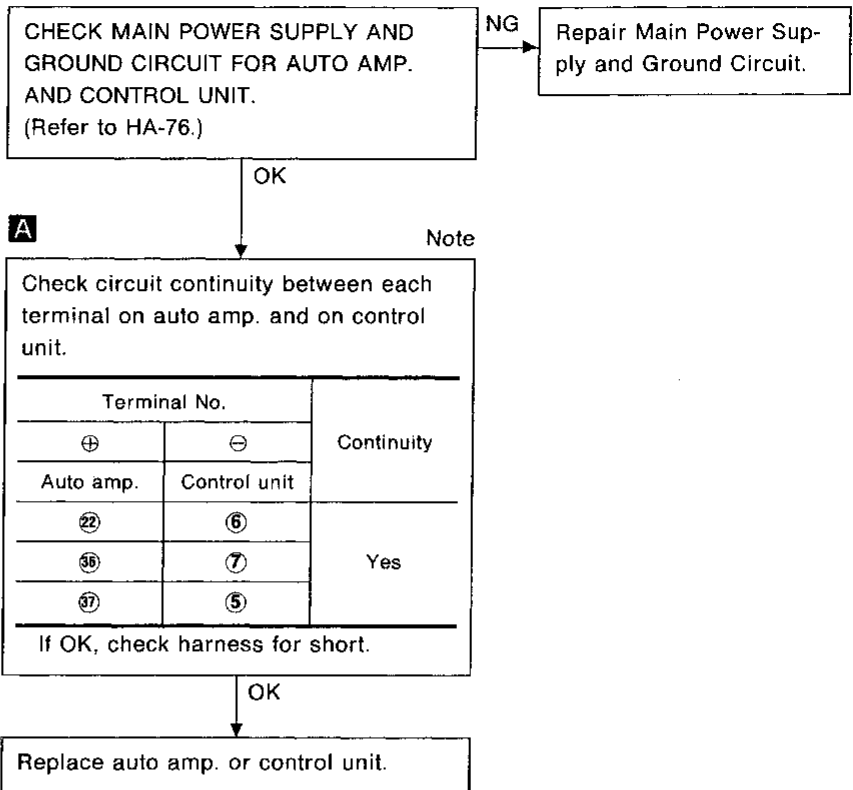

**Note:**

If the result is NG after checking circuit continuity, repair harness or connector.

GI  
 MA  
 EM  
 LC  
 EC  
 FE  
 AT  
 PD  
 FA  
 RA  
 BR  
 ST  
 RS  
 BT  
**HA**  
 EL  
 IDX

# TROUBLE DIAGNOSES

## Diagnostic Procedure 2

**SYMPTOM:** Ambient sensor circuit is open. (2; is indicated on auto amp. as a result of conducting Self-diagnosis STEP 2; or AMBIENT SENSOR [OPEN] (-a) is indicated on CONSULT as a result of conducting "SELF-DIAGNOSIS RESULTS" mode with CONSULT.)

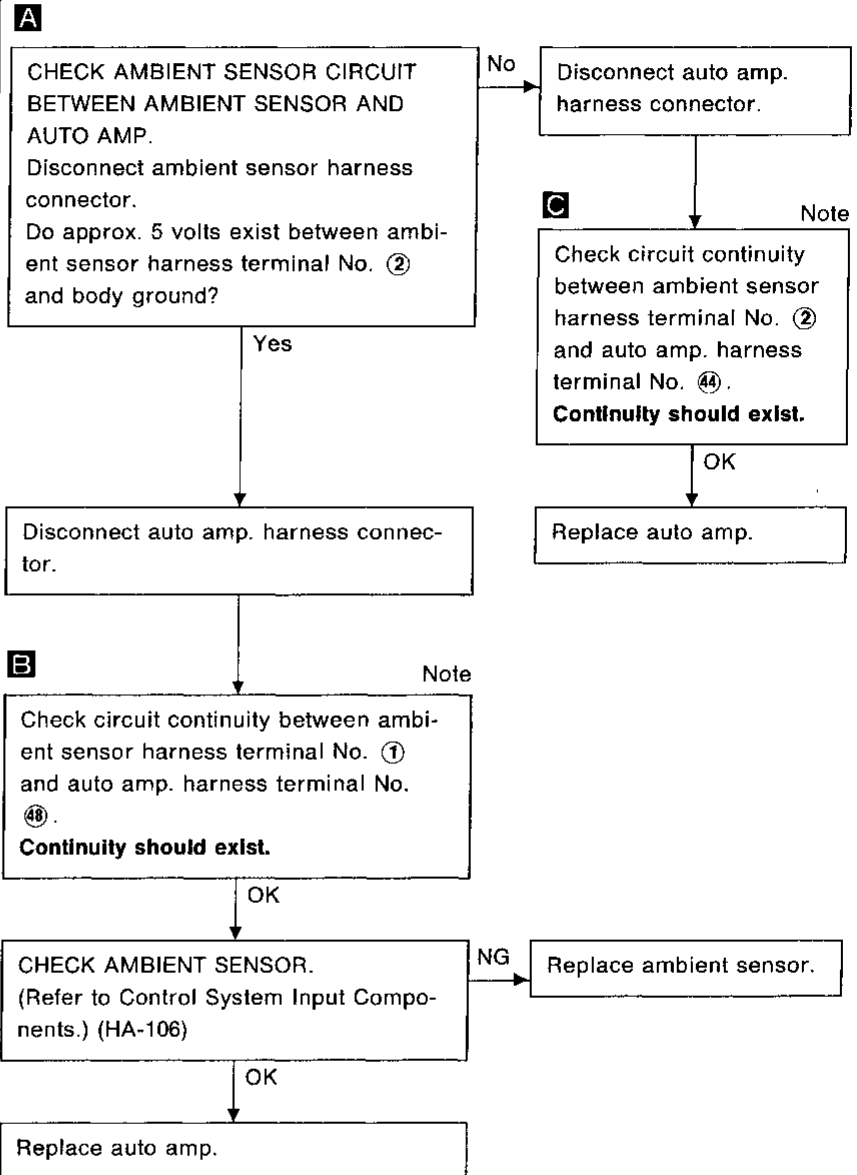
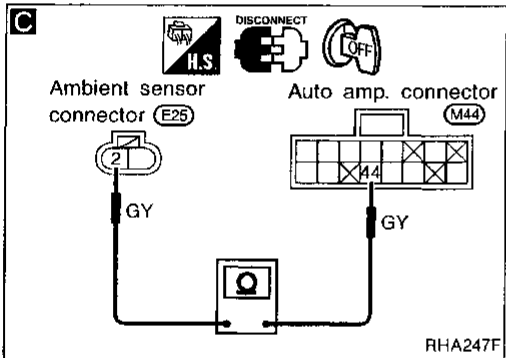
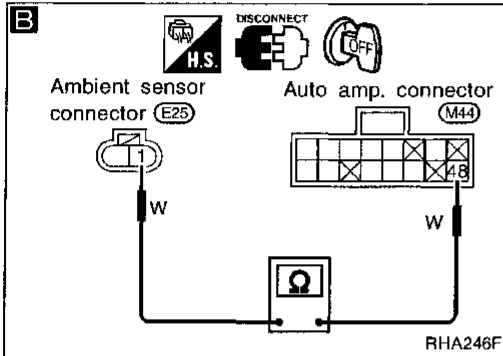
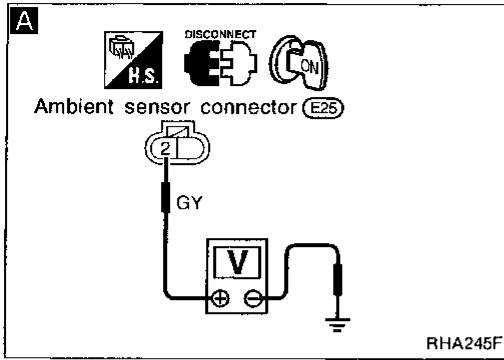

**Note:**

If the result is NG after checking circuit continuity, repair harness or connector.

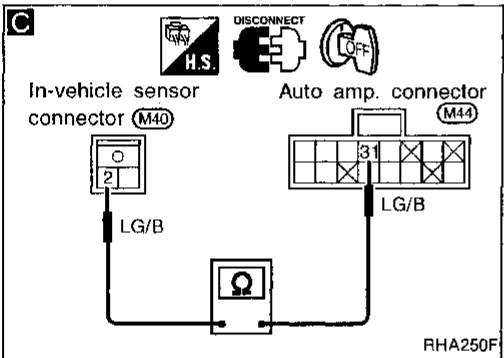
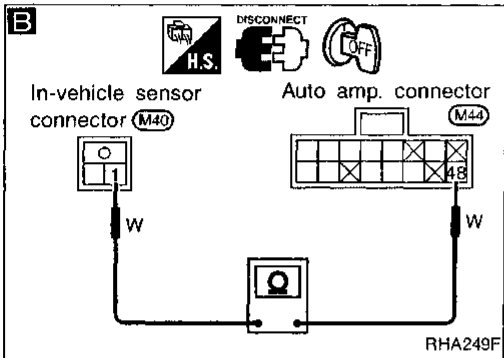
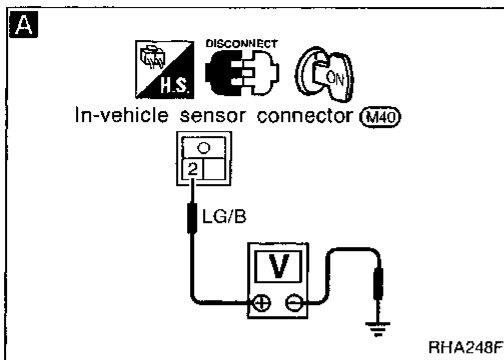

## Diagnostic Procedure 3

**SYMPTOM:** In-vehicle sensor circuit is open. (22 is indicated on auto amp. as a result of conducting Self-diagnosis STEP 2; or IN-VEHICLE SENSOR [OPEN] (-a) is indicated on CONSULT as a result of conducting "SELF-DIAGNOSIS RESULTS" mode with CONSULT.)

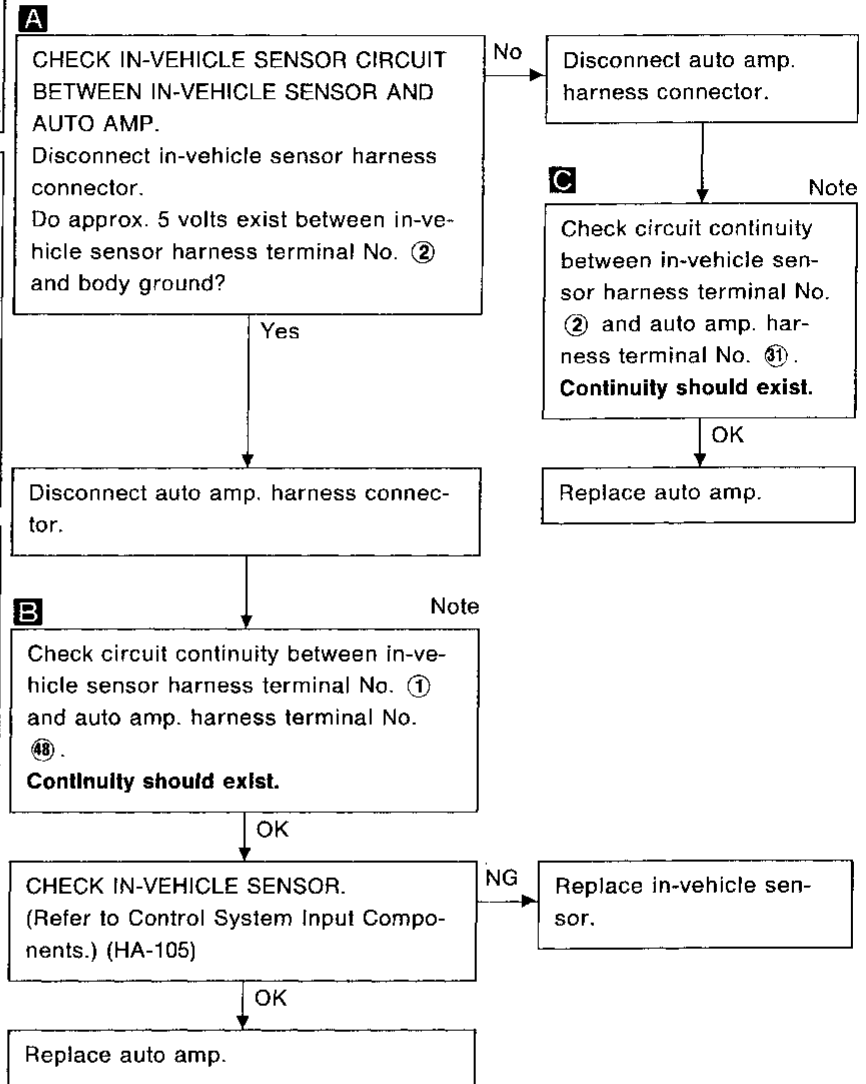

**Note:**

If the result is NG after checking circuit continuity, repair harness or connector.

## Diagnostic Procedure 4

**SYMPTOM:** Thermal transmitter circuit is open. (23 is indicated on auto amp. as a result of conducting Self-diagnosis STEP 2; or COOLANT TEMP SEN [OPEN] (-a) is indicated on CONSULT as a result of conducting "SELF-DIAGNOSIS RESULTS" mode with CONSULT.)

### Check thermal transmitter

Refer to METER AND GAUGES in EL section.

GI

MA

EM

LC

EC

FE

AT

PD

EA

RA

BR

ST

RS

BT

HA

EL

IDX

# TROUBLE DIAGNOSES

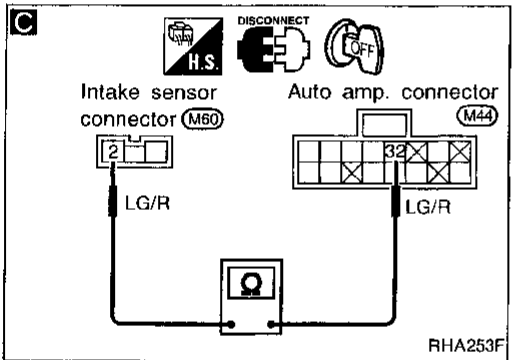
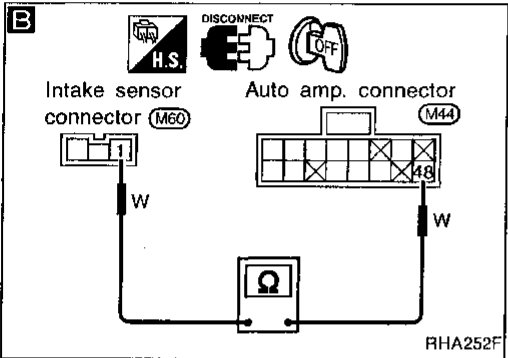
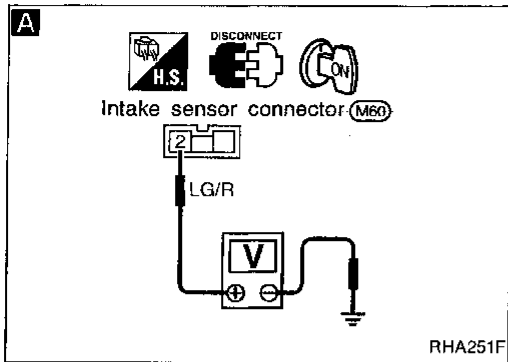

## Diagnostic Procedure 5

**SYMPTOM:** Intake sensor circuit is open. (24 is indicated on auto amp. as a result of conducting Self-diagnosis STEP 2; or INTAKE SENSOR [OPEN] (·a) is indicated on CONSULT as a result of conducting "SELF-DIAGNOSIS RESULTS" mode with CONSULT.)

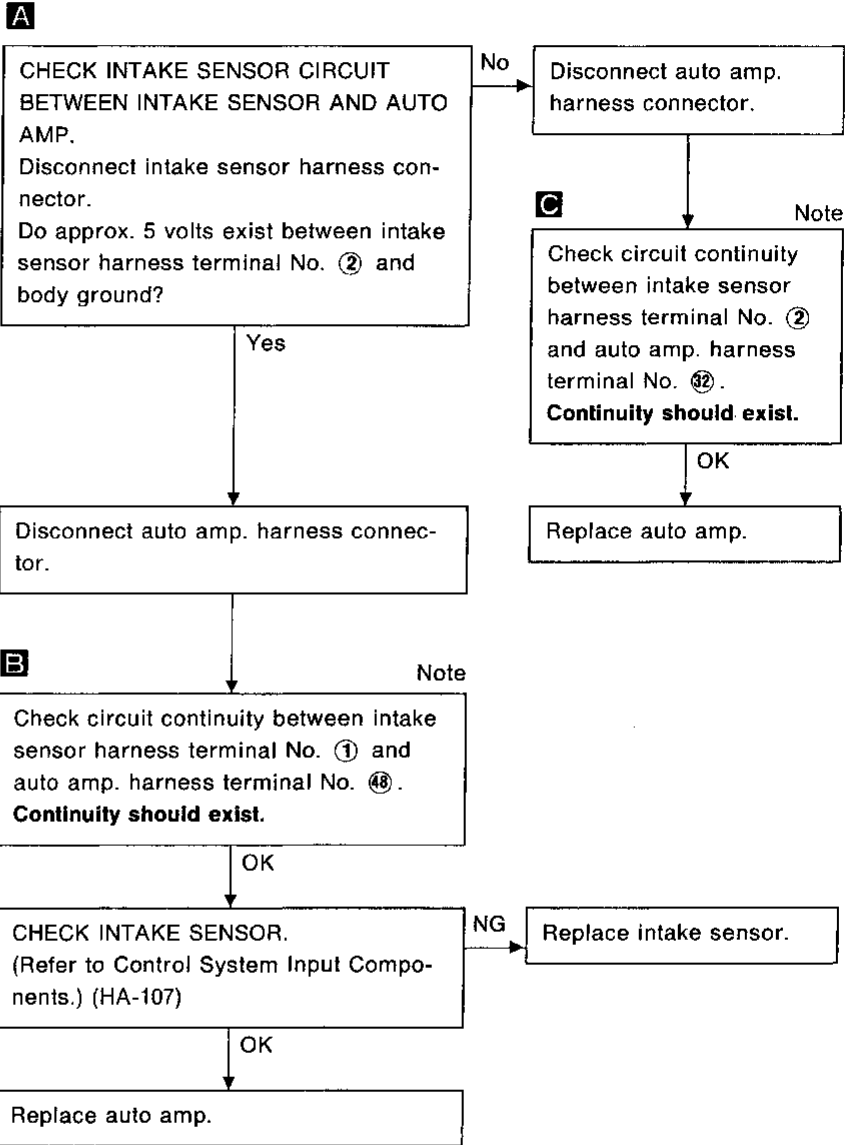

**Note:**

If the result is NG after checking circuit continuity, repair harness or connector.



# TROUBLE DIAGNOSES

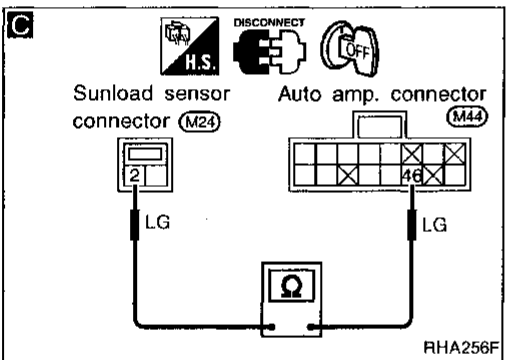
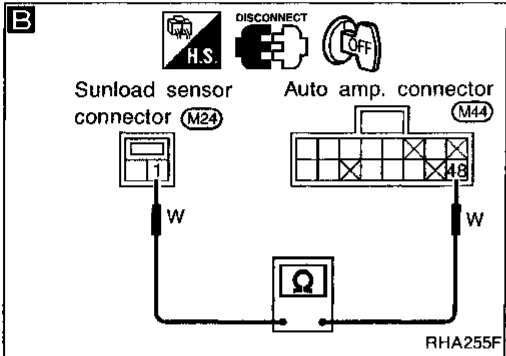
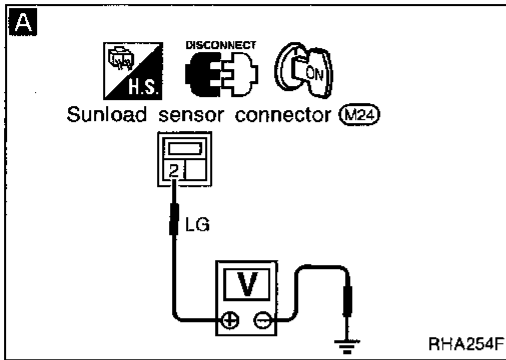

## Diagnostic Procedure 6

**SYMPTOM:** Sunload sensor circuit is open. (25 is indicated on auto amp. as a result of conducting Self-diagnosis STEP 2; or **SUNLOAD SENSOR [OPEN] (-a)** is indicated on CONSULT as a result of conducting "SELF-DIAGNOSIS RESULTS" mode with CONSULT.)

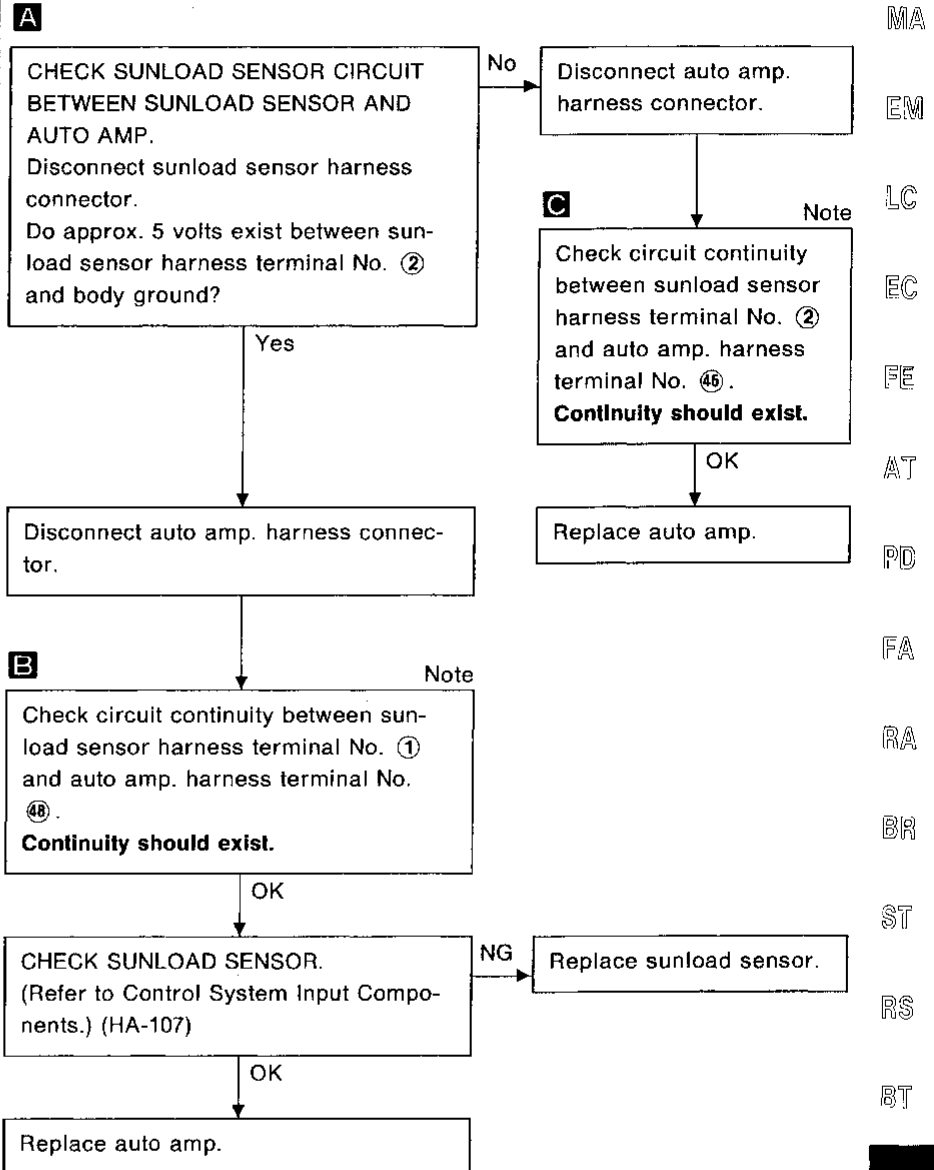

**Note:**

If the result is NG after checking circuit continuity, repair harness or connector.

GI  
MA  
EM  
LC  
EC  
FE  
AT  
PD  
FA  
RA  
BR  
ST  
RS  
BT  
HA  
EL  
IDX

# TROUBLE DIAGNOSES

## Diagnostic Procedure 7

**SYMPTOM:** PBR circuit is open. (25 is indicated on auto amp. as a result of conducting Self-diagnosis STEP 2; or PBR [OPEN] (-a) is indicated on CONSULT as a result of conducting "SELF-DIAGNOSIS RESULTS" mode with CONSULT.)

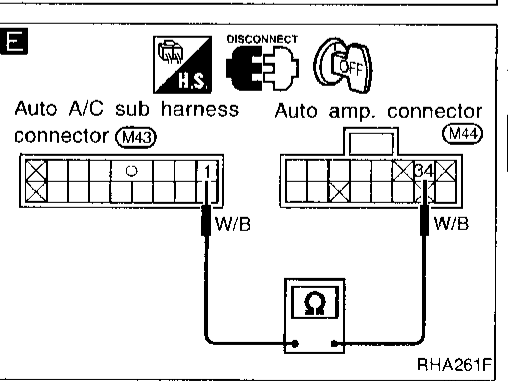
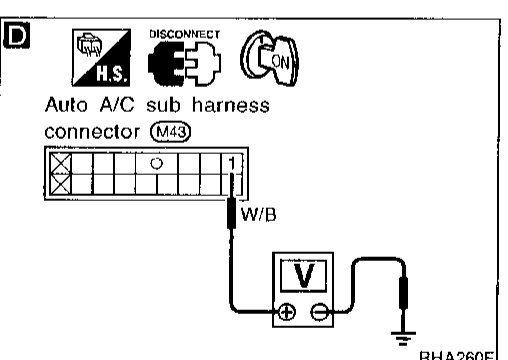
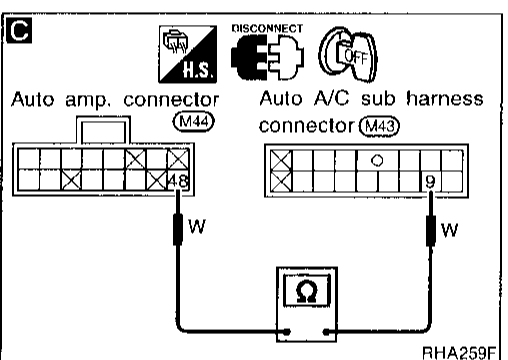
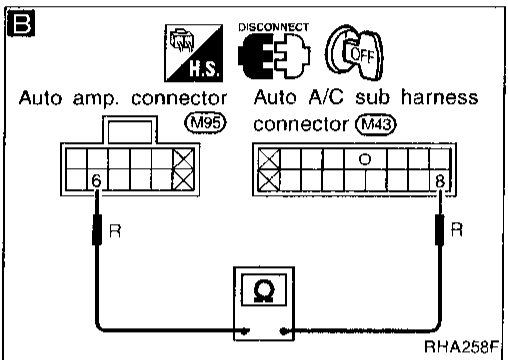
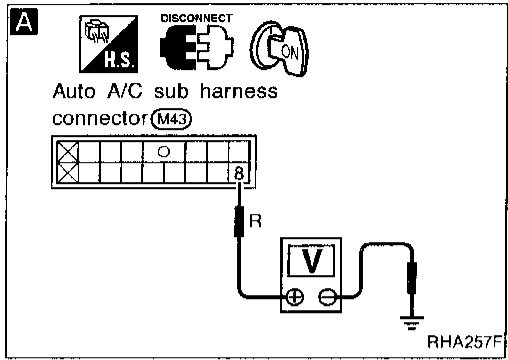

```

    graph TD
      A["A  
CHECK PBR CIRCUIT BETWEEN PBR  
AND AUTO AMP.  
Disconnect auto A/C sub harness  
connector.  
Do approx. 5 volts exist between auto  
A/C sub harness terminal No. ⑧ and  
body ground?"]
      B["B Note  
Check circuit continuity  
between auto A/C sub  
harness terminal No. ⑧  
and auto amp. harness  
terminal No. ⑥ .  
Continuity should exist."]
      C["C Note  
Check circuit continuity between auto  
A/C sub harness terminal No. ⑨ and  
auto amp. harness terminal No. ④⑧ .  
Continuity should exist."]
      D["D  
CHECK PBR CIRCUIT BETWEEN PBR  
AND AUTO AMP.  
Reconnect auto amp. harness connec-  
tor.  
Do approx. 5 volts exist between auto  
A/C sub harness terminal No. ① and  
body ground?"]
      E["E Note  
Check circuit continuity  
between auto A/C sub  
harness terminal No. ①  
and auto amp. harness  
terminal No. ④④ .  
Continuity should exist."]
      F["CHECK PBR  
(Refer to Control System Output Com-  
ponents.) (HA-112)"]
      G["Replace auto amp."]
      H["Replace air mix door  
motor (PBR)."]

      A -- No --> B
      A -- Yes --> C
      B -- OK --> G
      C -- OK --> G
      C -- NG --> D
      D -- No --> E
      D -- Yes --> F
      E -- OK --> G
      E -- NG --> H
      F -- OK --> G
      F -- NG --> H
  
```

**Note:**  
If the result is NG after checking circuit continuity, repair harness or connector.

# TROUBLE DIAGNOSES

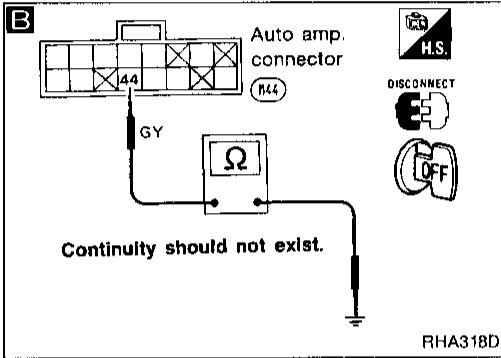
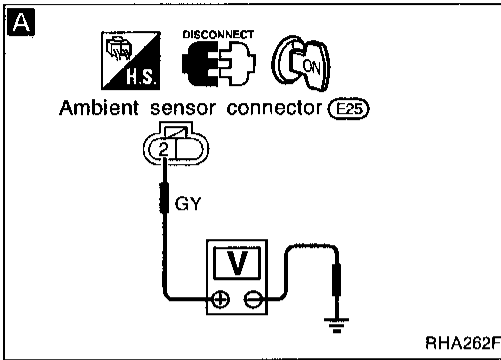

## Diagnostic Procedure 8

**SYMPTOM:** Ambient sensor circuit is shorted. (-2; is indicated on auto amp. as a result of conducting Self-diagnosis STEP 2; or AMBIENT SENSOR [SHORT] (-b) is indicated on CONSULT as result of conducting "SELF-DIAGNOSIS RESULTS" mode with CONSULT.)

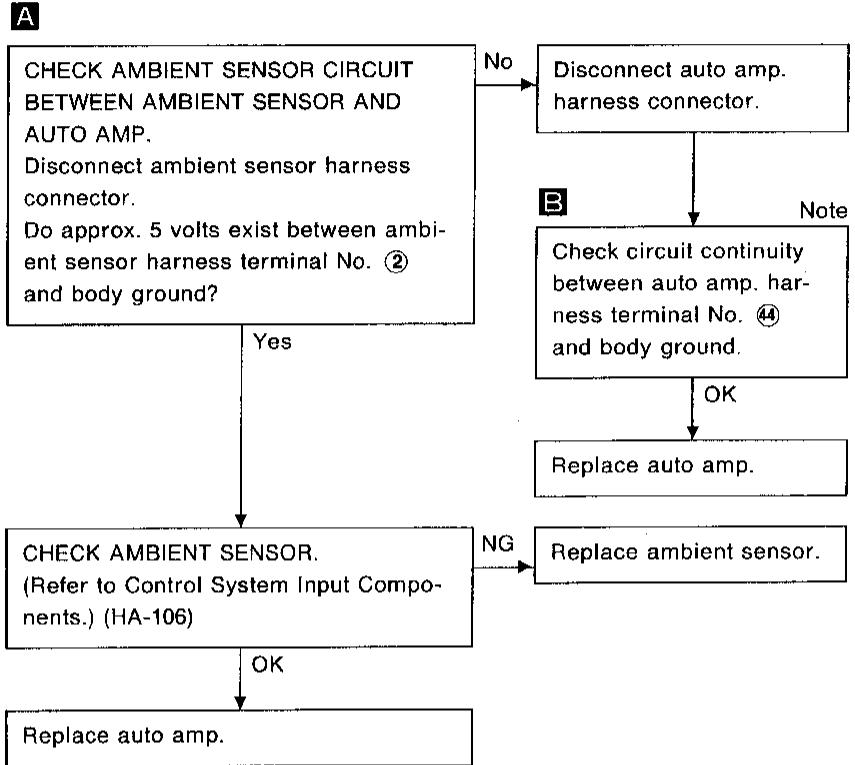

**Note:**

If the result is NG after checking circuit continuity, repair harness or connector.

GI

MA

EM

LC

EC

FE

AT

PD

FA

RA

BR

ST

RS

BT

HA

EL

IDX

# TROUBLE DIAGNOSES

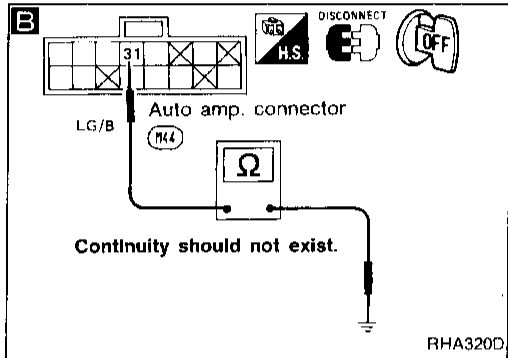
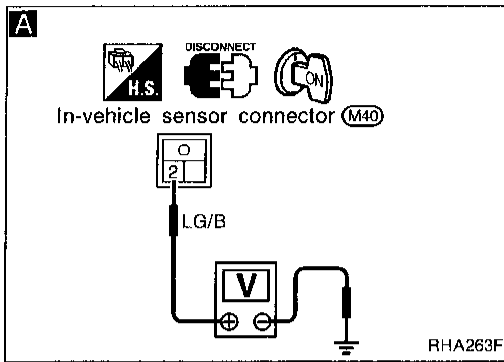

## Diagnostic Procedure 9

**SYMPTOM:** In-vehicle sensor circuit is shorted. (-22 is indicated on auto amp. as a result of conducting Self-diagnosis STEP 2; or IN-VEHICLE SENSOR [SHORT] (·b) is indicated on CONSULT as a result of conducting "SELF-DIAGNOSIS RESULTS" mode with CONSULT.)

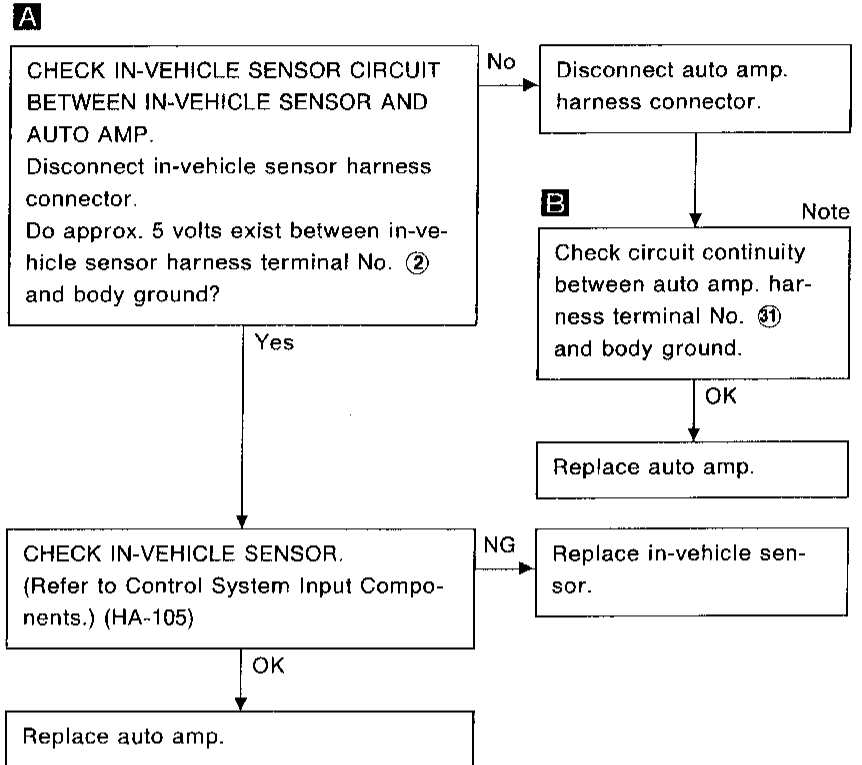

**Note:**

If the result is NG after checking circuit continuity, repair harness or connector.

# TROUBLE DIAGNOSES

## Diagnostic Procedure 10

**SYMPTOM:** Thermal transmitter circuit is shorted. (-23 is indicated on auto amp. as a result of conducting Self-diagnosis STEP 2; or COOLANT TEMP SEN [SHORT] (-b) is indicated on CONSULT as a result of conducting "SELF-DIAGNOSIS RESULTS" mode with CONSULT.)

Check thermal transmitter

Refer to METER AND GAUGES in EL section.

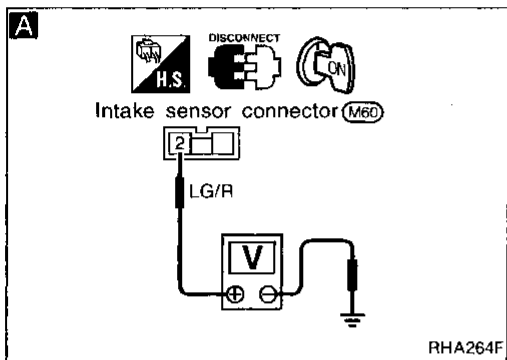

RHA264F

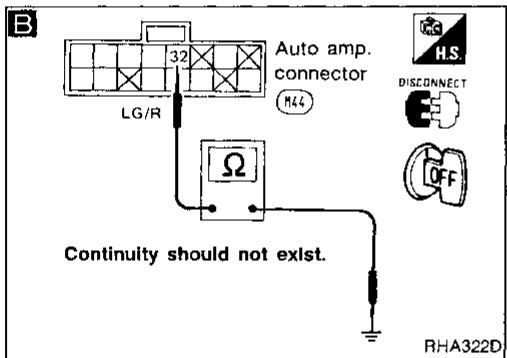

RHA322D

## Diagnostic Procedure 11

**SYMPTOM:** Intake sensor circuit is shorted. (-24 is indicated on auto amp. as a result of conducting Self-diagnosis STEP 2; or INTAKE SENSOR [SHORT] (-b) is indicated on CONSULT as a result of conducting "SELF-DIAGNOSIS RESULTS" mode with CONSULT.)

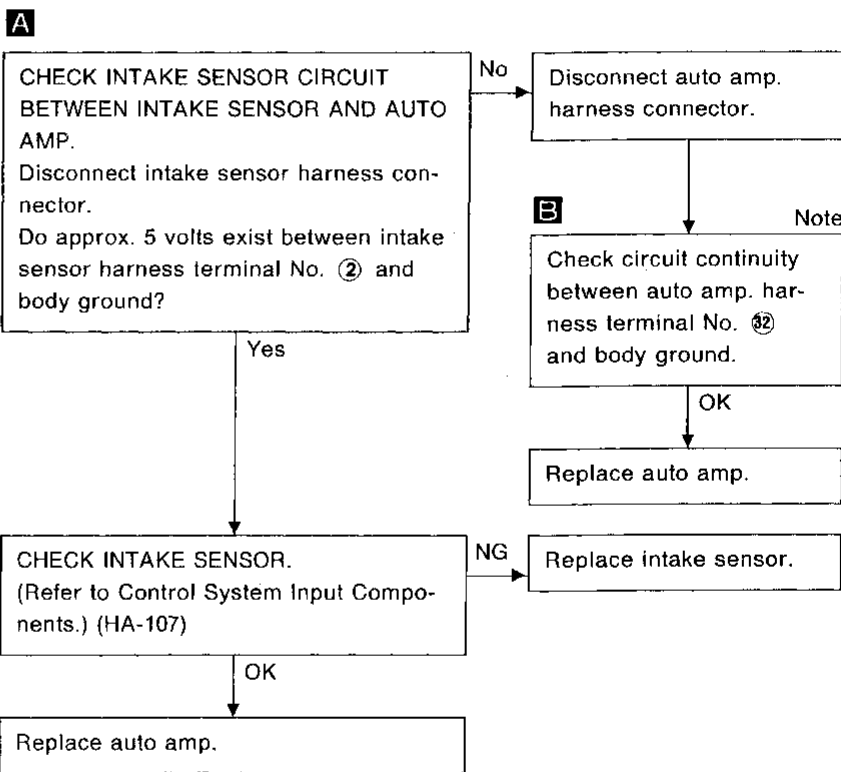

**Note:**

If the result is NG after checking circuit continuity, repair harness or connector.

# TROUBLE DIAGNOSES

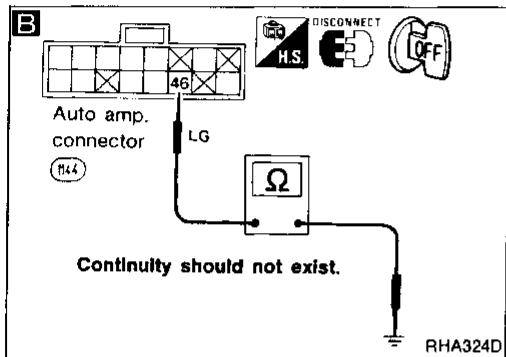
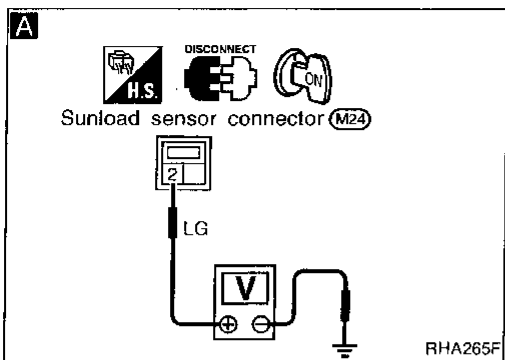

## Diagnostic Procedure 12

**SYMPTOM:** Sunload sensor circuit is shorted. (-25 is indicated on auto amp. as a result of conducting Self-diagnosis STEP 2; or SUNLOAD SENSOR [SHORT] (-b) is indicated on CONSULT as a result of conducting "SELF-DIAGNOSIS RESULTS" mode with CONSULT.)

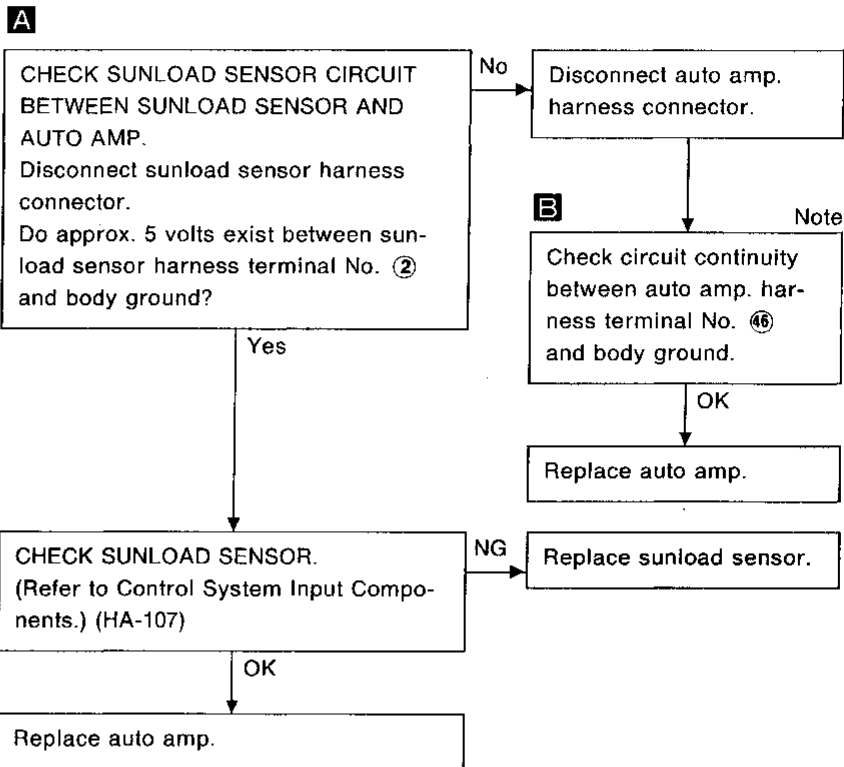

**Note:**

If the result is NG after checking circuit continuity, repair harness or connector.

# TROUBLE DIAGNOSES

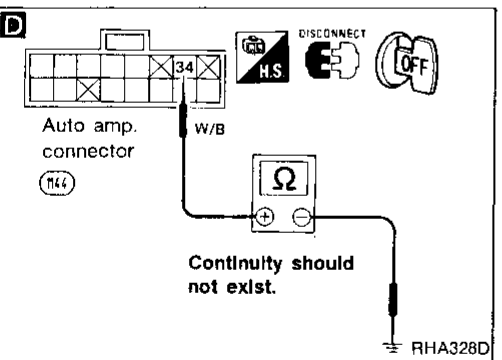
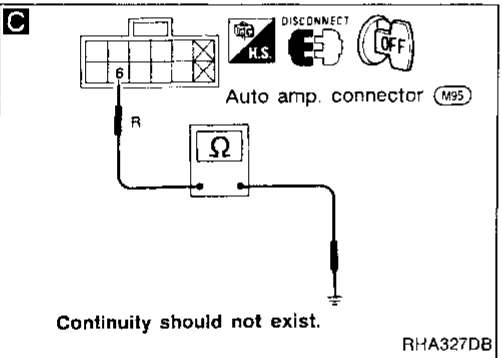
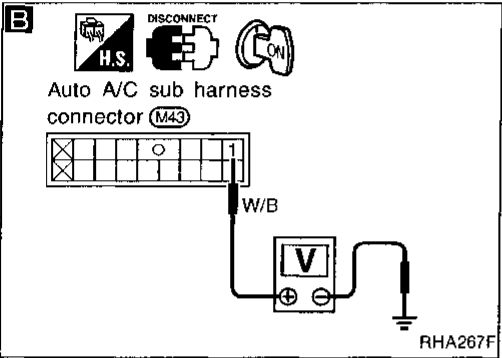
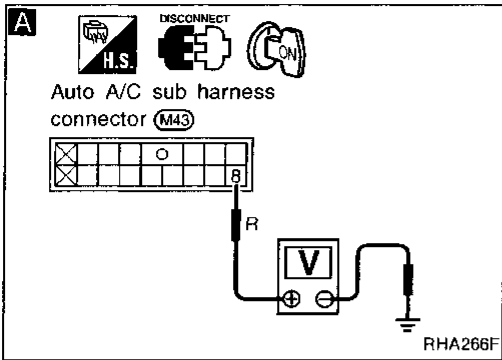

## Diagnostic Procedure 13

**SYMPTOM:** PBR circuit is shorted. (-25 is indicated on auto amp. as a result of conducting Self-diagnosis STEP 2; or PBR [SHORT] (-b) is indicated on CONSULT as a result of conducting "SELF-DIAGNOSIS RESULTS" mode with CONSULT.)

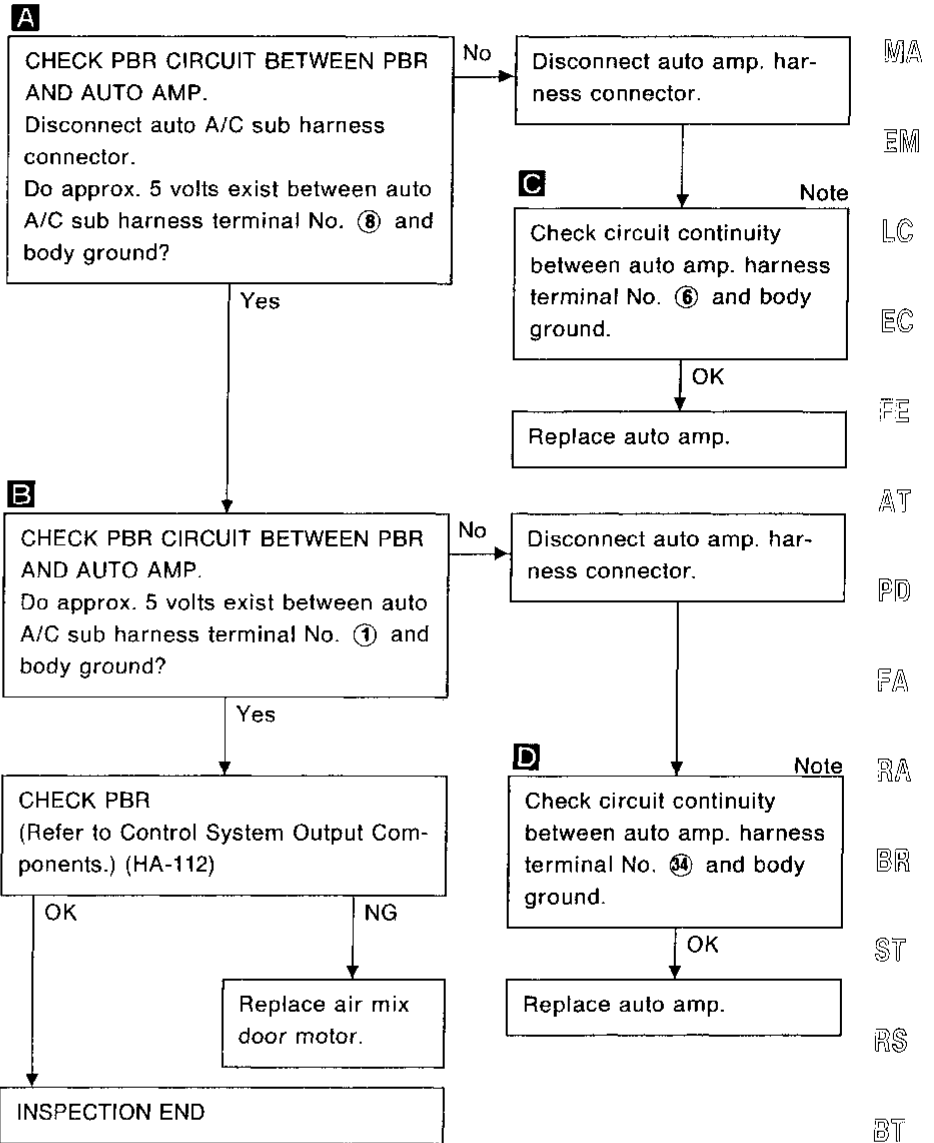

**Note:**  
if the result is NG after checking circuit continuity, repair harness or connector.

GI

MA

EM

LC

EC

FE

AT

PD

FA

RA

BR

ST

RS

BT

HA

EL

DX

# TROUBLE DIAGNOSES

## Diagnostic Procedure 14

**SYMPTOM: Mode door motor does not operate normally.**

- Perform Preliminary Check 1 before referring to the following flow chart.

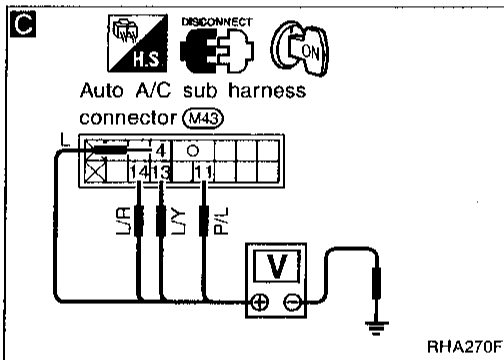
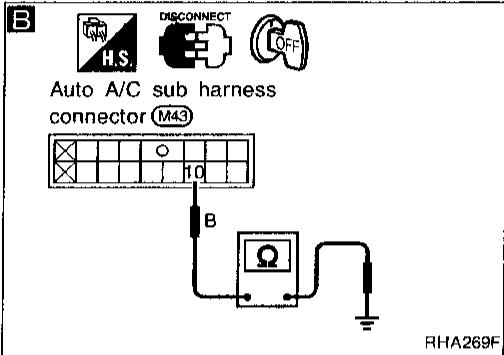
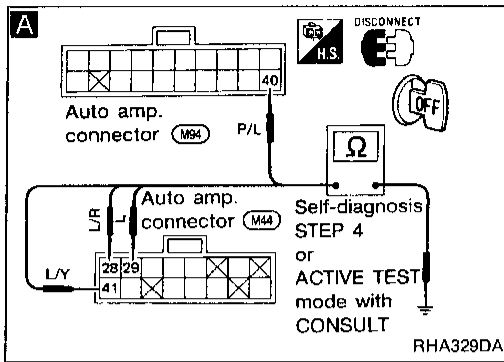

### A CHECK MODE DOOR MOTOR POSITION SWITCH.

1. Set up mode VENT in "ACTIVE TEST" mode with CONSULT.  
or  
 Set up code No. 41 in Self-diagnosis STEP 4.
2. Disconnect auto amp. harness connector after turning ignition switch OFF.
3. Check if continuity exists between terminal No. 28 29 40 41 of auto amp. harness connector and body ground.
4. Using above procedure, check for continuity in the other modes indicated in the chart below.

Set mode	Code No.	Condition	Terminal No.		Continuity
			⊕	⊖	
VENT	41	VENT	28 or 29	Body ground	Yes
B/L 1	42 or 43	B/L	28 or 41		
F/D 1	44	F/D 1	28 or 41		
F/D 2	45	F/D 2	28 or 40		
DEF	46	DEF	40 or 41		

If OK, check harness for short.

OK

INSPECTION END

NG → Disconnect auto A/C sub harness connector.

**B** Note  
CHECK BODY GROUND CIRCUIT FOR MODE DOOR MOTOR.  
Does continuity exist between auto A/C sub harness terminal No. 10 and body ground?

Yes

Reconnect auto amp. harness connector.

**C**  
CHECK POWER SUPPLY FOR MODE DOOR MOTOR CONTROL CIRCUIT.  
Do approx. 5 volts exist between auto A/C sub harness terminals and body ground?

Terminal No.		Voltage
⊕	⊖	
10	Body ground	Approx. 5V
4		
11		
13		

Yes

**A**

(Go to next page.)

**B**

**Note:**

If the result is No after checking circuit continuity, repair harness or connector.



# TROUBLE DIAGNOSES

## Diagnostic Procedure 14 (Cont'd)

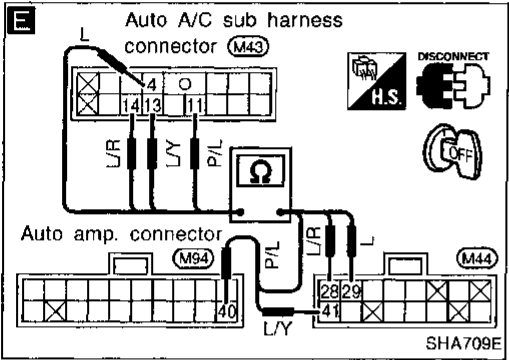
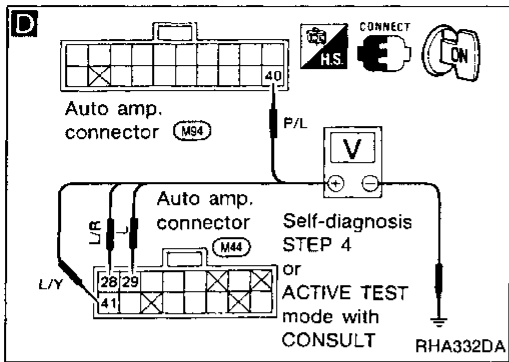

A

Note

Check auto A/C sub harness for short or open

OK

Reconnect auto A/C sub harness connector.

D

**CHECK MODE DOOR MOTOR POSITION SWITCH.**

- Set up "ACTIVE TEST" mode with CONSULT.  
or  
Set up Self-diagnosis STEP 4.
- Measure voltage across auto amp. harness terminals and body ground.

Set mode	Code No.	Condition	Terminal No.				Body ground
			⊕		⊖		
			40	28	41	29	
VENT	41	VENT	5V	0V	5V	0V	
B/L 1	42 or 43	B/L	5V	5V	0V	0V	
F/D 1	44	F/D 1	5V	0V	0V	5V	
F/D 2	45	F/D 2	0V	0V	5V	5V	
DEF	46	DEF	0V	5V	0V	5V	

0V: Approx. 0V, 5V: Approx. 5V

B

Note

Check circuit continuity between each terminal on auto amp. and on auto A/C sub harness.

Terminal No.		Continuity
⊕	⊖	
Auto amp. 28	Auto A/C sub harness 14	Yes
29	4	
40	11	
41	13	

If OK, check harness for short.

OK

Replace auto amp.

OK

Check MODE DOOR MECHANISM Refer to HA-102

NG

C

**Note:**  
If the result is NG after checking circuit continuity, repair harness or connector.

GI  
MA  
EM  
LC  
EC  
FE  
AT  
PD  
FA  
RA  
BR  
ST  
RS  
BT

HA

EL  
IDX

# TROUBLE DIAGNOSES

## Diagnostic Procedure 14 (Cont'd)

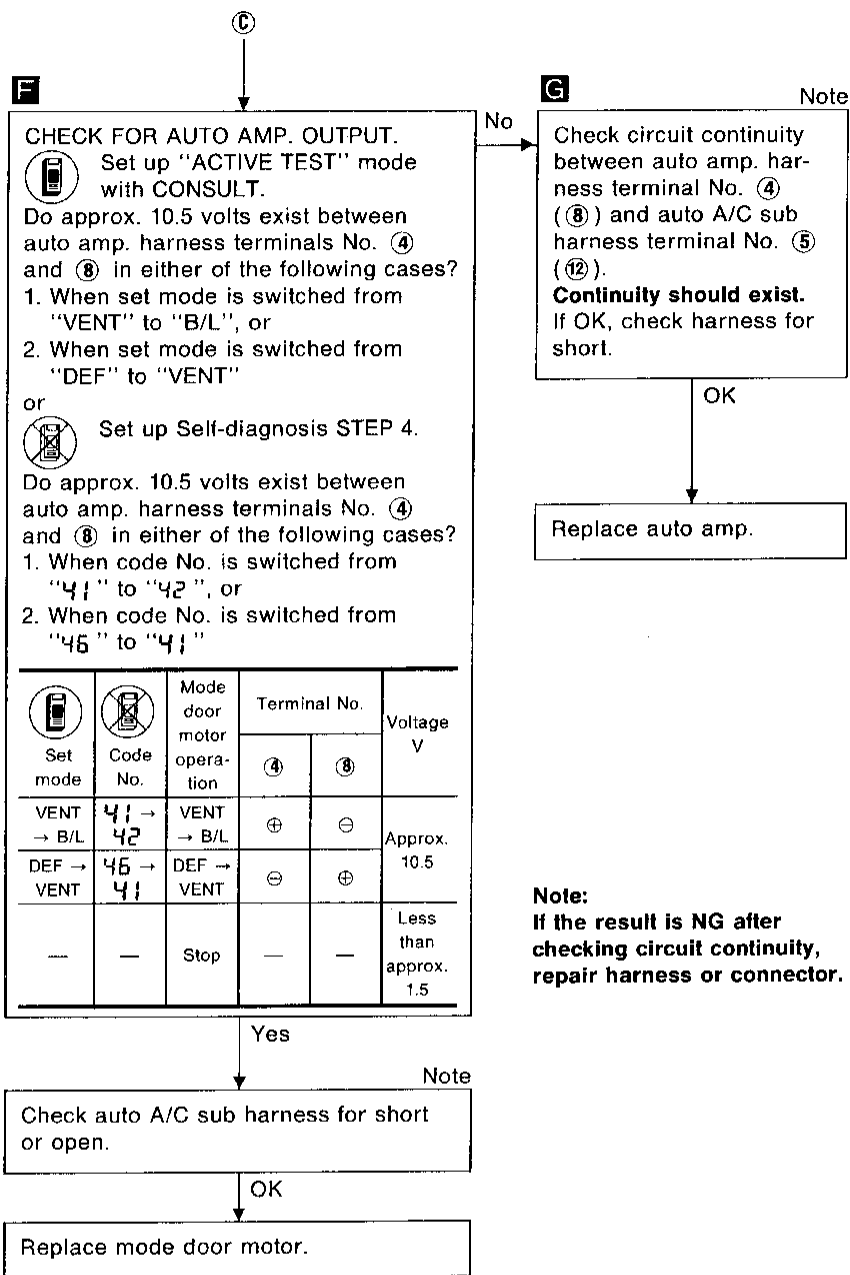
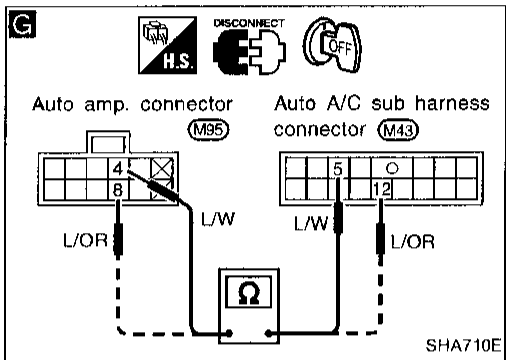
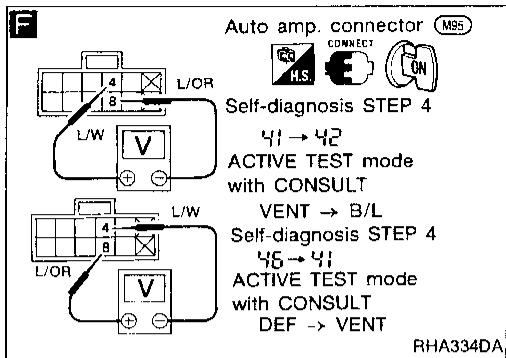

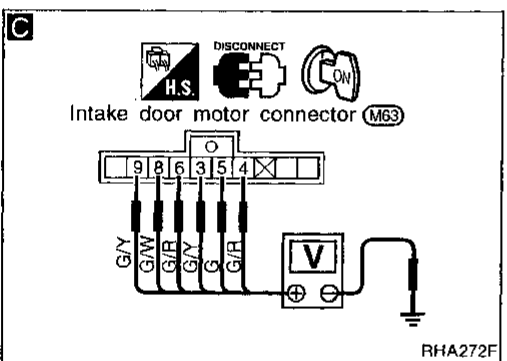
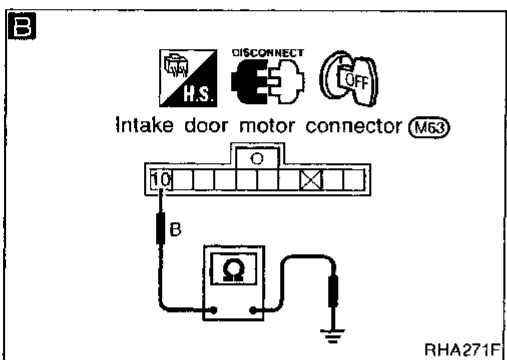
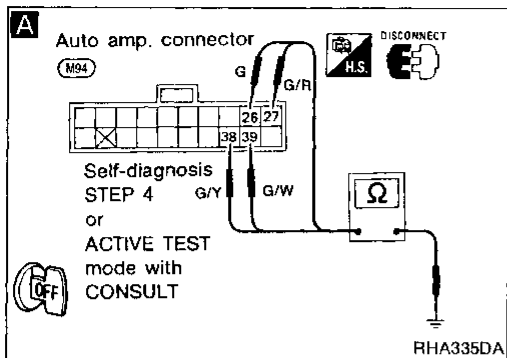

## Diagnostic Procedure 15

**SYMPTOM: Intake door motor does not operate normally.**

- Perform Preliminary Check 2 before referring to the following flow chart.

- A** CHECK INTAKE DOOR MOTOR POSITION SWITCH.
1. Set up mode REC in "ACTIVE TEST" mode with CONSULT.
  - or Set up code No. 41 in Self-diagnosis STEP 4.
  2. Disconnect auto amp. harness connector after turning ignition switch OFF.
  3. Check if continuity exists between terminal No. 26 27 38 39 of auto amp. harness connector and body ground.
  4. Using above procedure, check for continuity in the other modes indicated in the chart below.

Set mode	Code No.	Condition	Terminal No.		Continuity
			⊕	⊖	
REC	41	REC	26 or 27	Body ground	Yes
20% FRE	42 or 43	20% FRE	28 or 34		
80% FRE	44	80% FRE	38 or 39		
FRE	45 or 46	FRE	27 or 39		

NG → Disconnect intake door motor harness connector.

**B** Note  
CHECK BODY GROUND CIRCUIT FOR INTAKE DOOR MOTOR.  
Does continuity exist between intake door motor harness terminal No. 10 and body ground?

Yes → Reconnect auto amp. harness connector.

**C** CHECK POWER SUPPLY FOR INTAKE DOOR MOTOR CONTROL CIRCUIT.  
Do approx. 5 volts exist between intake door motor harness terminals and body ground?

Terminal No.		Voltage
⊕	⊖	
4	Body ground	Approx. 5V
5		
3		
6		
8		
9		

Yes → Reconnect intake door motor harness connector.

No →

OK → INSPECTION END

(A) (Go to next page.)  
(B)

**Note:**  
If the result is No after checking circuit continuity, repair harness or connector.

GI  
MA  
EM  
LC  
EC  
FE  
AT  
PD  
FA  
RA  
BR  
ST  
RS  
BT  
HA

# TROUBLE DIAGNOSES

## Diagnostic Procedure 15 (Cont'd)

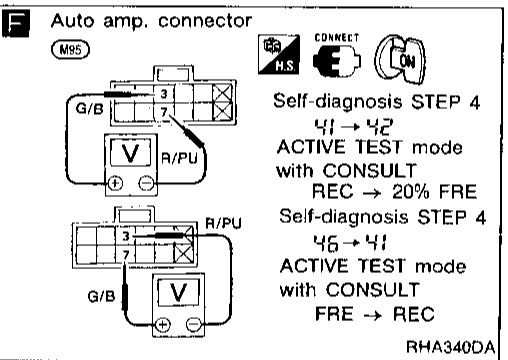
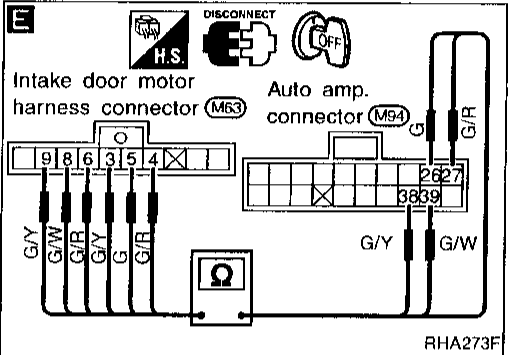
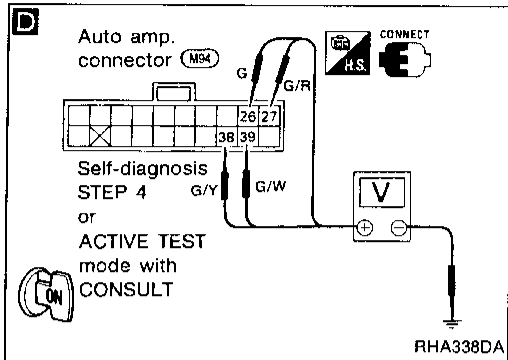

**D**

**CHECK INTAKE DOOR MOTOR POSITION SWITCH.**

1. Set up "ACTIVE TEST" mode with CONSULT.  
or  
 Set up Self-diagnosis STEP 4.
2. Measure voltage across auto amp. harness terminals and body ground.

Set mode	Code No.	Condition	Terminal No.				Body ground
			⊕	⊖	⊕	⊖	
REC	41	REC	5V	0V	5V	0V	Yes
20% FRE	42 or 43	20% FRE	5V	5V	0V	0V	
80% FRE	44	80% FRE	0V	5V	0V	5V	
FRE	45	FRE	0V	0V	5V	5V	

0V: Approx. 0V, 5V: Approx. 5V

**E**

**Note**

Check circuit continuity between each terminal on auto amp. and on intake door motor.

Terminal No.		Continuity
⊕	⊖	
Auto amp. 27	Intake door motor 4 or 6	Yes
26	5	
38	3 or 9	
39	8	

If OK, check harness for short.

OK → Replace auto amp.

NG → Replace intake door motor.

**F**

**CHECK FOR AUTO AMP. OUTPUT.**

Set up "ACTIVE TEST" mode with CONSULT.  
Do approx. 10.5 volts exist between auto amp. harness terminals No. ③ and ⑦ in either of the following cases?

1. When set mode is switched from "REC" to "20% FRE", or
2. When set mode is switched from "FRESH" to "REC"

or

Set up Self-diagnosis STEP 4.  
Do approx. 10.5 volts exist between auto amp. harness terminals No. ③ and ⑦ in either of the following cases?

1. When code No. is switched from "41" to "42", or
2. When code No. is switched from "45" to "41"

Set mode	Code No.	Intake door motor operation	Terminal No.		Voltage V
			③	⑦	
REC → 20% FRE	41 → 42	REC → 20% FRE	⊕	⊖	Approx. 10.5
FRE → REC	45 → 41	FRE → REC	⊖	⊕	
—	—	Stop	—	—	Less than approx. 1.5

Yes → Replace intake door motor.

OK → Replace auto amp.

NG → Replace intake door motor.

No → Replace auto amp.

**Note:**  
If the result is NG after checking circuit continuity, repair harness or connector.

# TROUBLE DIAGNOSES

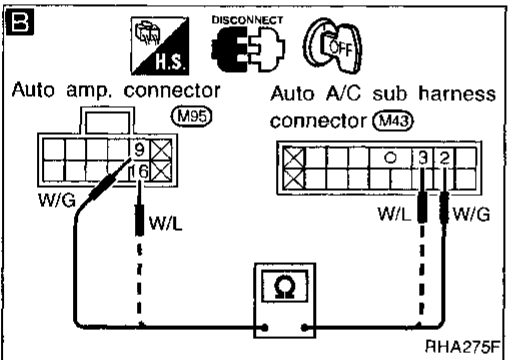
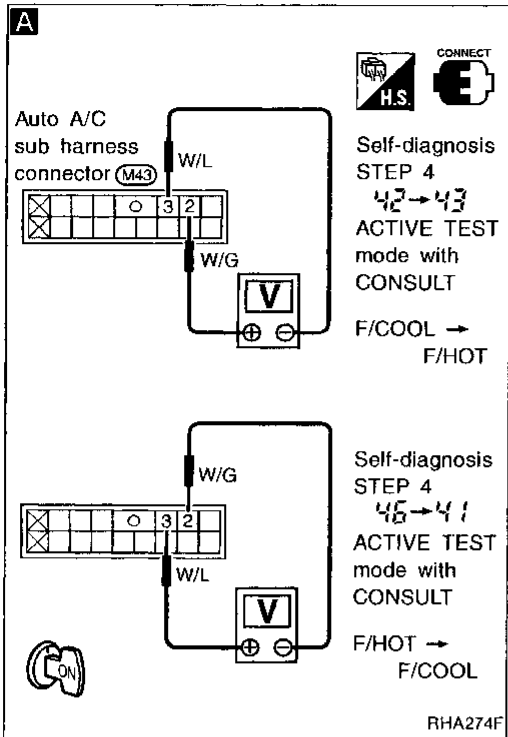

## Diagnostic Procedure 16

**SYMPTOM: Air mix door motor does not operate normally.**

- Perform Preliminary Check 7 before referring to the following flow chart.

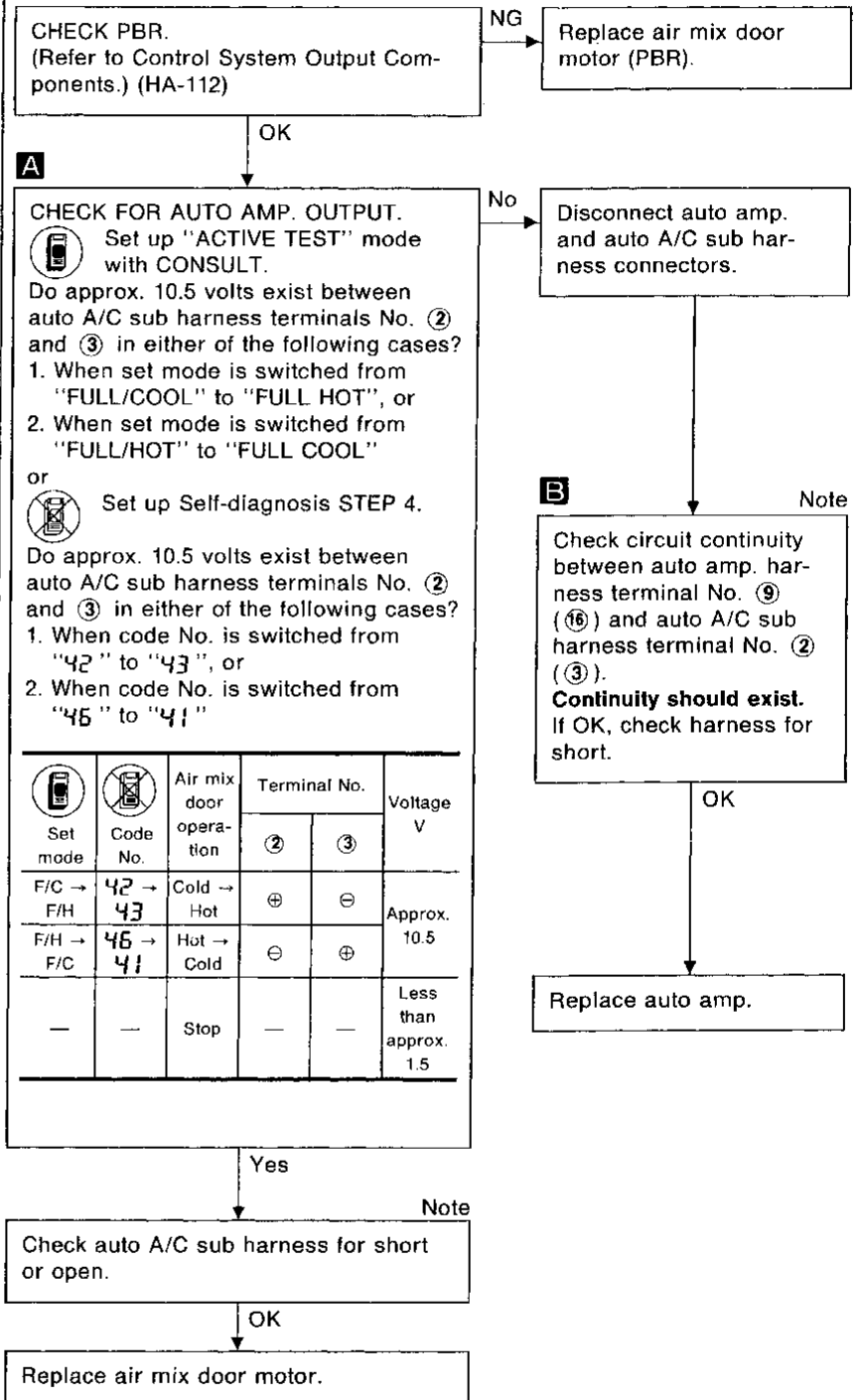

**Note:**

If the result is NG after checking circuit continuity, repair harness or connector.

GI  
MA  
EM  
LC  
EC  
FE  
AT  
PD  
FA  
RA  
BR  
ST  
RS  
BT  
HA  
EL  
IDX

# TROUBLE DIAGNOSES

## Diagnostic Procedure 17

**SYMPTOM:** Blower motor operation is malfunctioning under out of Starting Fan Speed Control.

- Perform Preliminary Check 5 before referring to the following flow chart.

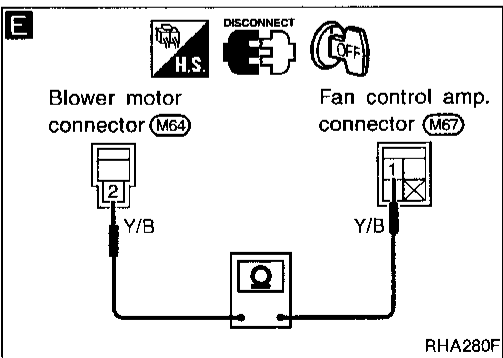
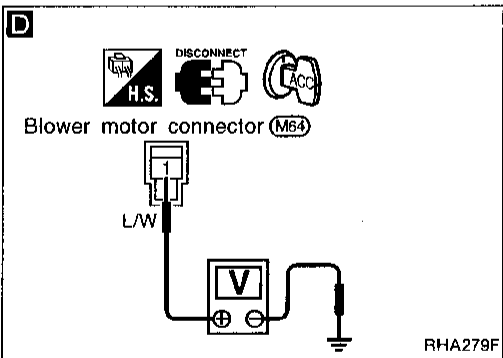
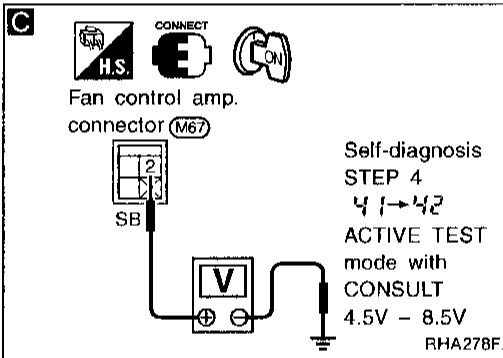
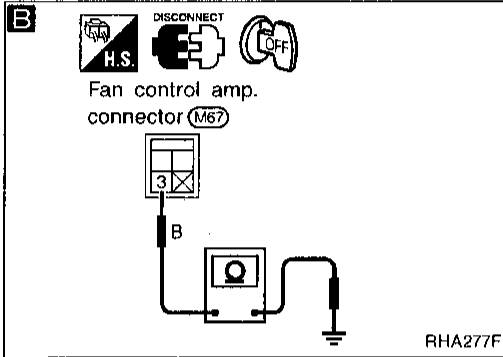
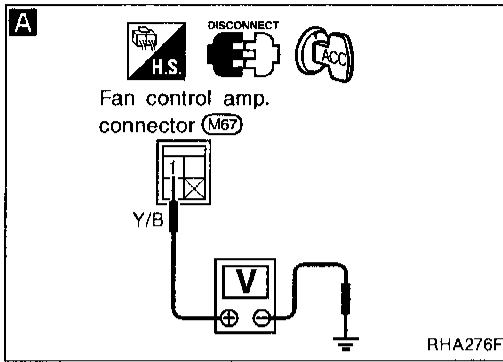

**A**

CHECK POWER SUPPLY FOR FAN CONTROL AMP.  
Disconnect fan control amp. harness connector.  
Do approx. 12 volts exist between fan control amp. harness terminal No. ① and body ground?

**B**

Check BODY GROUND CIRCUIT FOR FAN CONTROL AMP.  
Does continuity exist between fan control amp. harness terminal No. ③ and body ground?

Reconnect fan control amp. harness connector.

**C**

CHECK FOR AUTO AMP. OUTPUT.

1. Set up "ACTIVE TEST" mode with CONSULT.
- or Set up Self-diagnosis STEP 4.
2. Measure voltage across fan control amp. harness terminal No. ② and body ground.

		Terminal No.		Voltage
		⊕	⊖	
4.5V - 8.5V	41 - 42	②	Body ground	Approx. 1 → 3V

Replace fan control amp.

**Note:**

If the result is NG or No after checking circuit continuity, repair harness or connector.

**D**

CHECK POWER SUPPLY FOR BLOWER MOTOR.  
Disconnect blower motor harness connector.  
Do approx. 12 volts exist between blower motor harness terminal No. ① and body ground?

Check power supply circuit and 15A fuses (No. ⑩ and ⑪), located in the fuse block. Refer to EL section ("Wiring Diagram", "POWER SUPPLY ROUTING").

**E**

Check circuit continuity between blower motor harness terminal No. ② and fan control amp. harness terminal No. ①.  
**Continuity should exist.**  
If OK, check harness for short.

CHECK BLOWER MOTOR.  
(Refer to Electrical Components Inspection.) (HA-102)

Replace blower motor.

NG → **A** (Go to next page.)

# TROUBLE DIAGNOSES

## Diagnostic Procedure 17 (Cont'd)

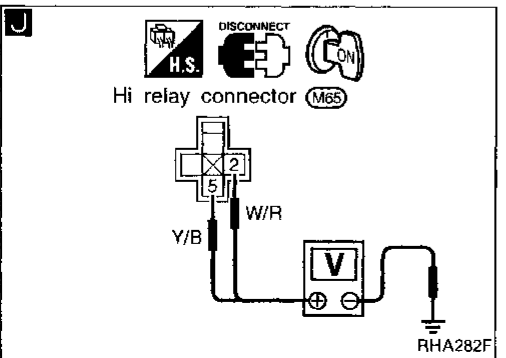
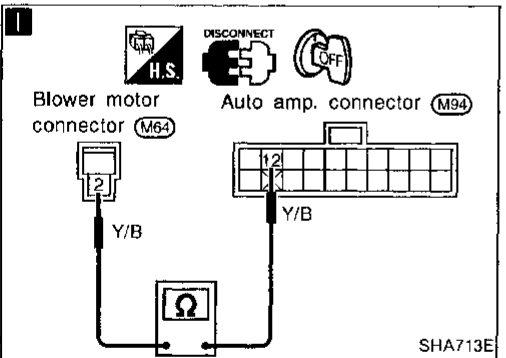
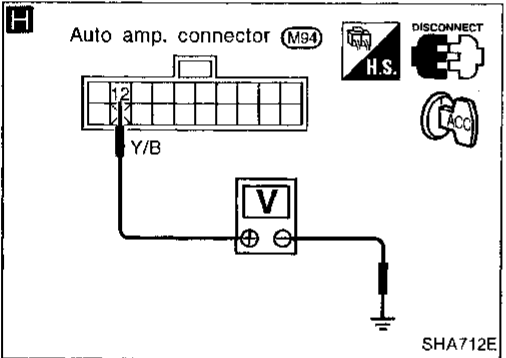
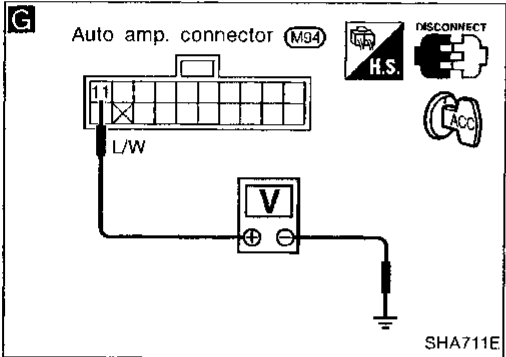
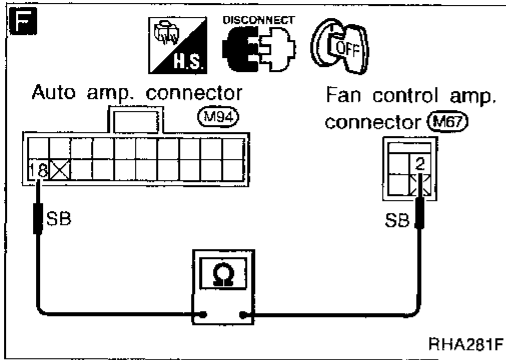

**A**

Disconnect auto amp. and fan control amp. harness connector.

**F** Note

Check circuit continuity between auto amp. harness terminal No. ⑱ and fan control amp. harness terminal No. ②. **Continuity should exist.** If OK, check harness for short.

**G**

CHECK FAN FEED BACK CIRCUIT. Do approx. 12 volts exist between auto amp. harness terminal No. ⑪ and body ground?

No

Check power supply circuit and 15A fuses (No. ⑩ and ⑪, located in the fuse block). Refer to EL section ("Wiring Diagram", "POWER SUPPLY ROUTING").

**H** Note

Do Approx. 12 volts exist between auto amp. harness terminal No. ⑫ and body ground?

No

Check circuit continuity between blower motor harness terminal No. ② and auto amp. harness terminal No. ⑫. **Continuity should exist.** If OK, check harness for short.

**J**

CHECK POWER SUPPLY FOR HI RELAY. Do approx. 12 volts exist between Hi relay harness terminals No. ②, ⑤ and body ground?

No

Check power supply circuit and 7.5A, 15 fuses (No. ⑩, ⑪ and ⑫, located in the fuse block). Refer to EL section ("Wiring Diagram", "POWER SUPPLY ROUTING").

**B**

(Go to next page.)

**Note:**  
If the result is NG or No after checking circuit continuity, repair harness or connector.

GI

MA

EM

LC

EC

FE

AT

PD

FA

RA

BR

ST

RS

BT

HA

EL

IDX

# TROUBLE DIAGNOSES

## Diagnostic Procedure 17 (Cont'd)

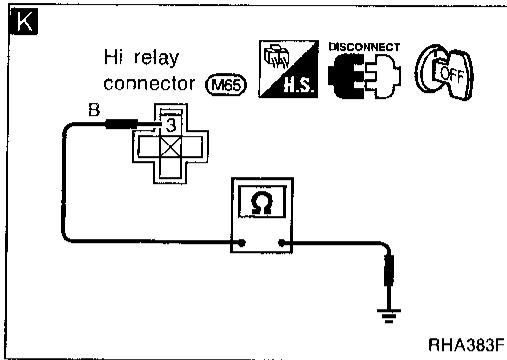

**B**

**K** Note

CHECK BODY GROUND CIRCUIT FOR HI RELAY.  
Does continuity exist between Hi relay harness terminal No. ③ and body ground?

Yes

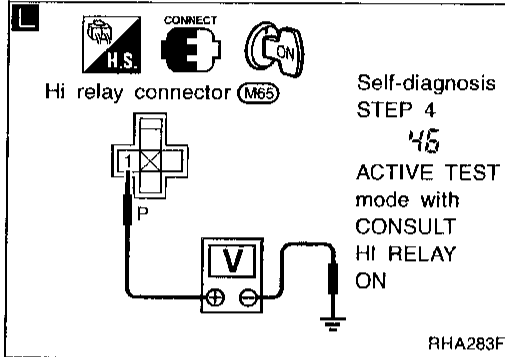

CHECK HI RELAY AFTER DISCONNECTING IT.  
(Refer to Electrical Components Inspection.) (HA-101)

NG

Replace Hi relay.

OK

Reconnect Hi relay.

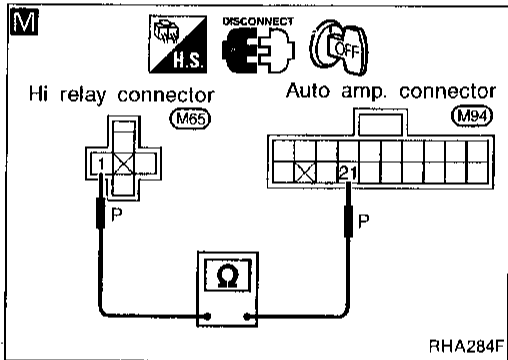

**L**

CHECK FOR AUTO AMP. OUTPUT.

1. Set up mode HI RELAY ON in "ACTIVE TEST" mode with CONSULT.

or

Set up code No. 46 in Self-diagnosis STEP 4.

2. Measure voltage across Hi relay harness terminal No. ① and body ground.

NG

Disconnect Hi relay and auto amp. harness connectors.

Set mode	Code No.	Terminal No.		Voltage
		⊕	⊖	
HI RELAY ON	46	①	Body ground	Less than approx. 1.5V

**M** Note

Check circuit continuity between Hi relay harness terminal No. ① and auto amp. harness terminal No. ⑳.

**Continuity should exist.**  
If OK, check harness for short.

OK

Replace auto amp.

OK

Replace blower motor.

**Note:**

If the result is NG or No after checking circuit continuity, repair harness or connector.



# TROUBLE DIAGNOSES

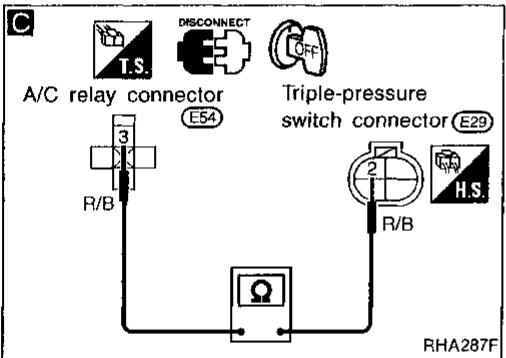
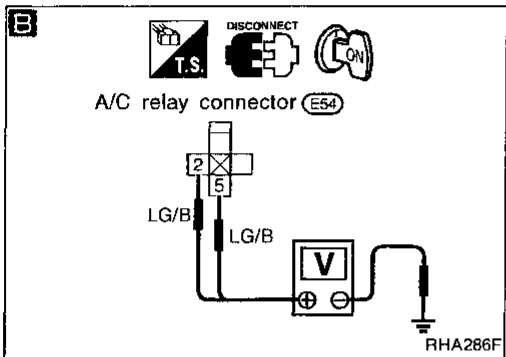
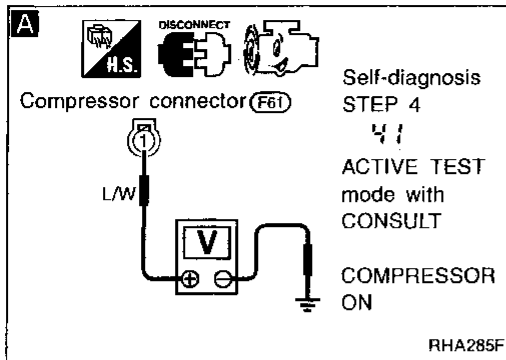

## Diagnostic Procedure 18

**SYMPTOM: Magnet clutch does not engage after performing Preliminary Check 6.**

- Perform Preliminary Check 6 before referring to the flow chart.

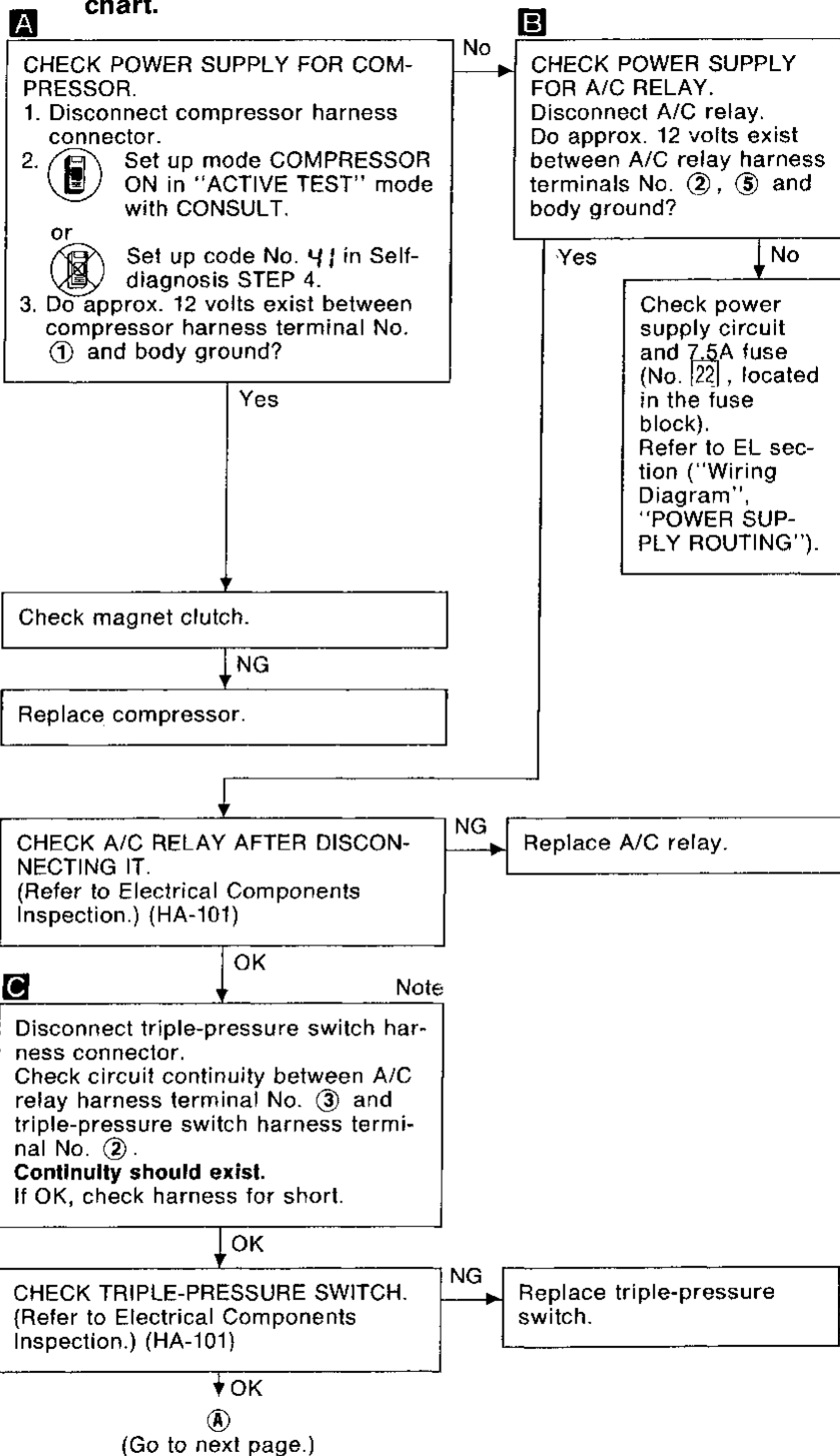

**Note:**

If the result is NG after checking circuit continuity, repair harness or connector.

# TROUBLE DIAGNOSES

## Diagnostic Procedure 18 (Cont'd)

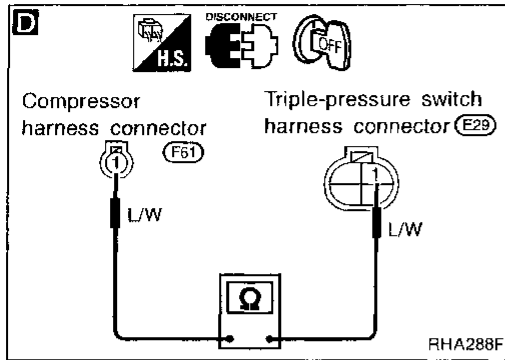

**D** Note

Check circuit continuity between compressor harness terminal No. ① and triple-pressure switch harness terminal No. ①.  
**Continuity should exist.**  
 If OK, check harness for short.

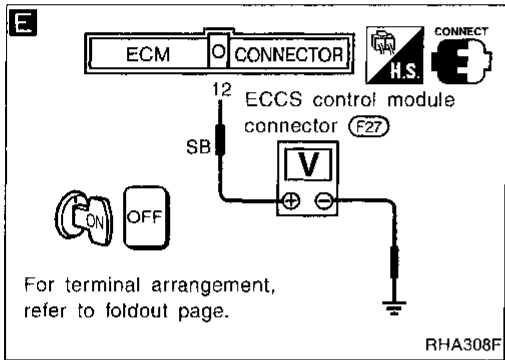

OK

Reconnect A/C relay.

**E**

CHECK COIL SIDE CIRCUIT OF A/C RELAY.  
 Do approx. 12 volts exist between ECCS control module harness terminal No. ⑫ and body ground?

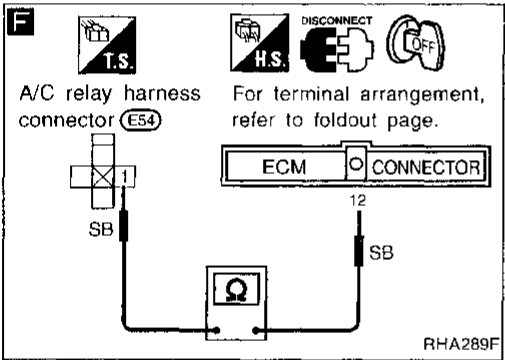

**F** Note

Disconnect A/C relay harness connector.  
 Check circuit continuity between A/C relay harness terminal No. ① and ECCS control module harness terminal No. ⑫.  
**Continuity should exist.**  
 If OK, check harness for short.

Yes

Reconnect ECCS control module harness connector.

ⓑ  
 (Go to next page)

**Note:**  
 If the result is NG after checking circuit continuity, repair harness or connector.

# TROUBLE DIAGNOSES

## Diagnostic Procedure 18 (Cont'd)

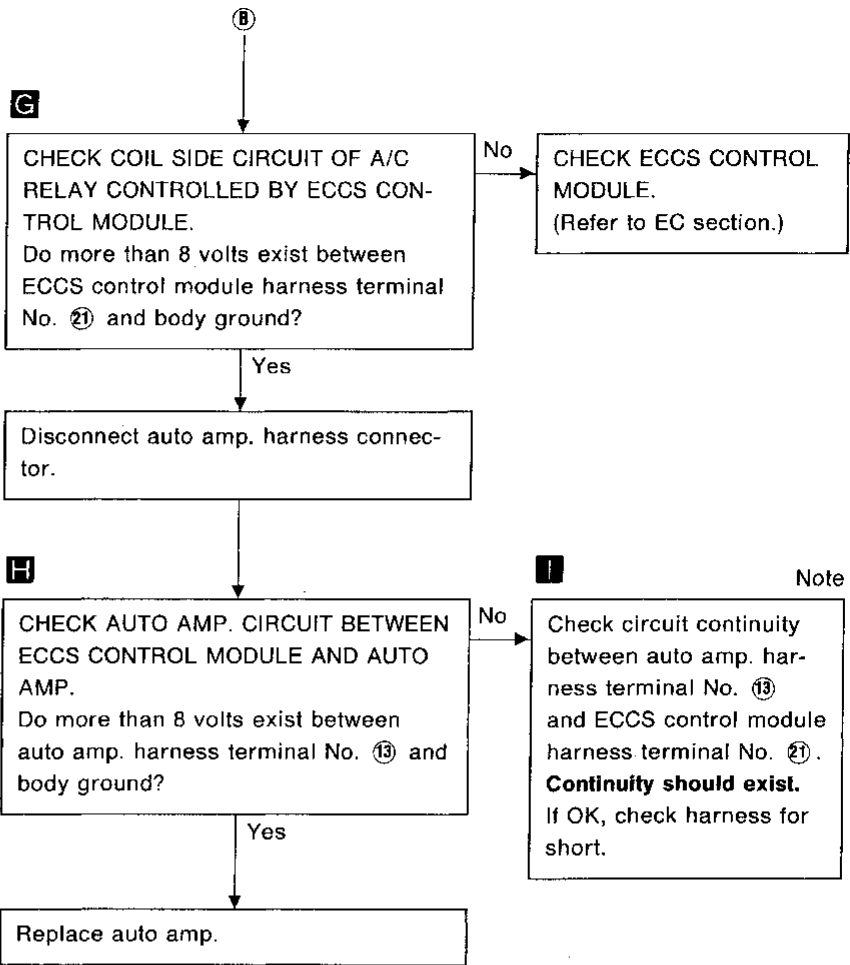
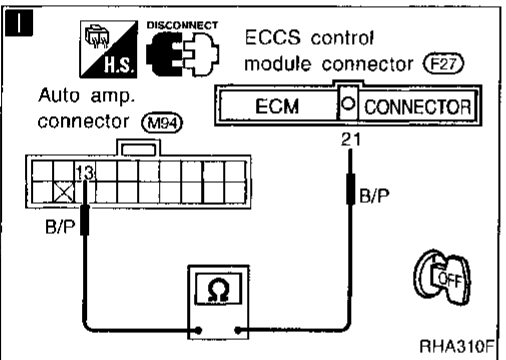
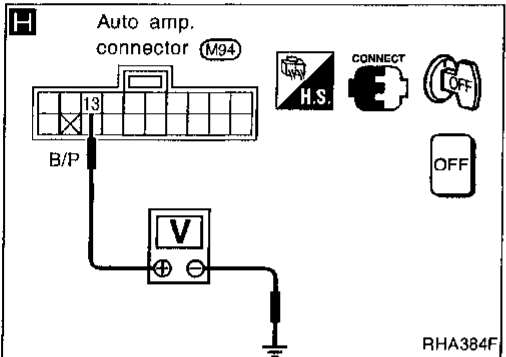
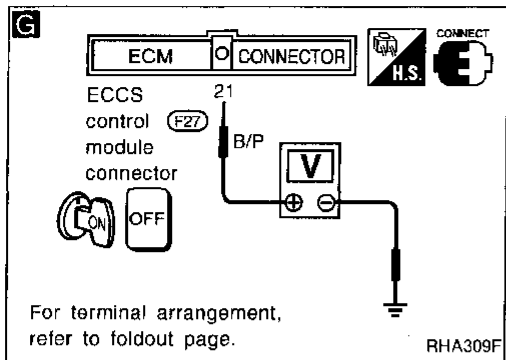

**Note:**  
If the result is NG after checking circuit continuity, repair harness or connector.

GI

MA

EM

LC

EC

FE

AT

PD

FA

RA

BR

ST

RS

BT

HA

EL

IDX

# TROUBLE DIAGNOSES

## Diagnostic Procedure 19

**SYMPTOM: Max. cold door motor does not operate normally.**

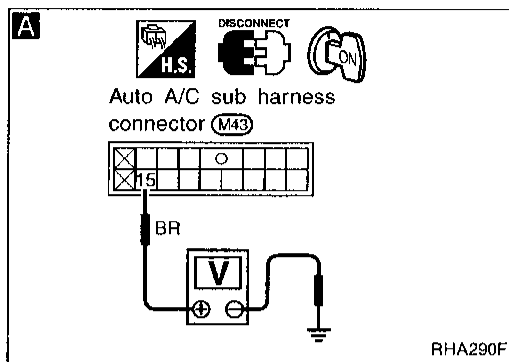

**A**

CHECK POWER SUPPLY FOR MAX. COLD DOOR MOTOR.

Disconnect auto A/C sub harness connector.

Do approx. 12 volts exist between auto A/C sub harness terminal No. ⑮ and body ground?

No

Check power supply circuit and 7.5A fuse (No. ⑦), located in the fuse block). Refer to EL section ("Wiring Diagram", POWER SUPPLY ROUTING").

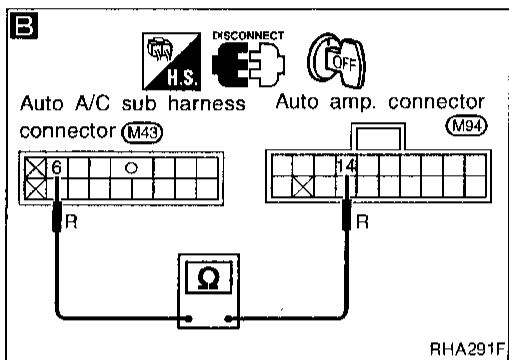

**B**

Disconnect auto amp. harness connector.

Check circuit continuity between auto amp. harness terminal No. ⑭ and auto A/C sub harness terminal No. ⑥.

**Continuity should exist.**

If OK, check harness for short

Yes

Note

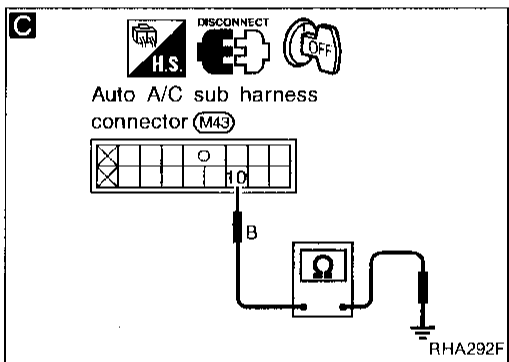

**C**

Check circuit continuity between auto A/C sub harness terminal No. ⑩ and body ground.

OK

Reconnect auto amp. and auto A/C sub harness connectors.

Note

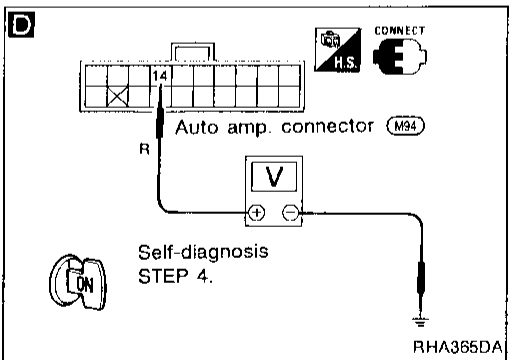

**D**

CHECK FOR AUTO AMP. OUTPUT.

Set up Self-diagnosis STEP 4.

Measure voltage across auto amp. harness terminal No. ⑭ and body ground.

NG

Replace auto amp.

Code No.	Max. cold door operation	Terminal No.		Voltage
		⊕	⊖	
42, 43	Open	⑭	Body ground	Less than approx. 1.5V
Other	Shut			Approx. 12V

OK

Replace max. cold door motor or max. cold door relay, or repair harness or connector.

**Note:**

If the result is NG after checking circuit continuity, repair harness or connector.

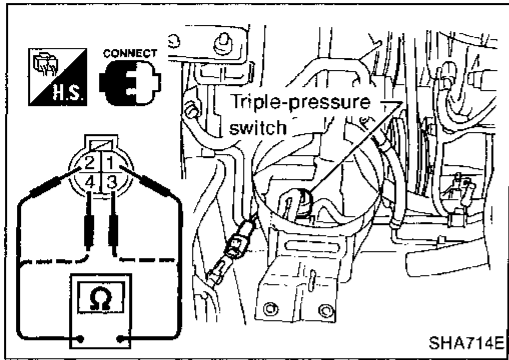

**Electrical Components Inspection**  
**TRIPLE-PRESSURE SWITCH**

	Terminals	High-pressure side line pressure kPa (kg/cm <sup>2</sup> , psi)	Operation	Continuity
Low-pressure side	① - ②	Increasing to 157 - 226 (1.6 - 2.3, 23 - 33)	ON	Exist
		Decreasing to 152.0 - 201.0 (1.55 - 2.05, 22.0 - 29.2)	OFF	Does not exist
Medium-pressure side*	③ - ④	Increasing to 1,422 - 1,618 (14.5 - 16.5, 206 - 235)	ON	Exist
		Decreasing to 1,226 - 1,618 (12.5 - 16.5, 178 - 235)	OFF	Does not exist
High-pressure side	① - ②	Decreasing to 1,863 - 2,256 (19 - 23, 270 - 327)	ON	Exist
		Increasing to 2,452 - 2,844 (25 - 29, 356 - 412)	OFF	Does not exist

\* For cooling fan motor operation.

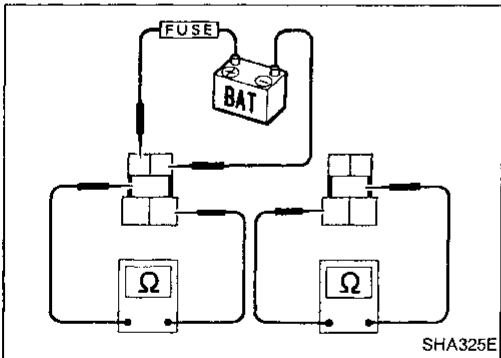

**MAX. COLD RELAY**

Check circuit continuity between terminals by supplying 12 volts to coil side terminals of relay.

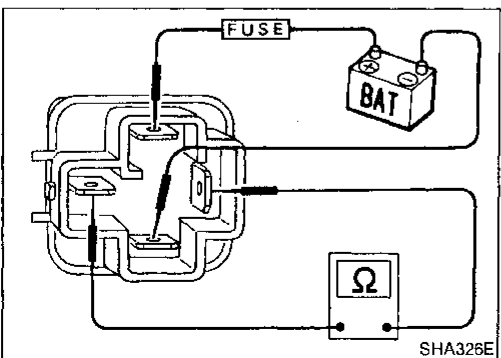

**A/C RELAY, COOLING FAN RELAY AND BLOWER HIGH RELAY**

Check circuit continuity between terminals by supplying 12 volts to coil side terminals of relay.

GE

MA

EM

LC

EC

FE

AT

PD

FA

RA

BR

ST

RS

BT

HA

EL

IDX

# TROUBLE DIAGNOSES

## Electrical Components Inspection (Cont'd)

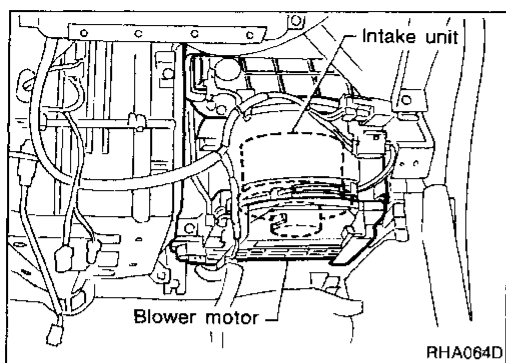

### BLOWER MOTOR

Confirm smooth rotation of the blower motor.

- Ensure that there are no foreign particles inside the intake unit.

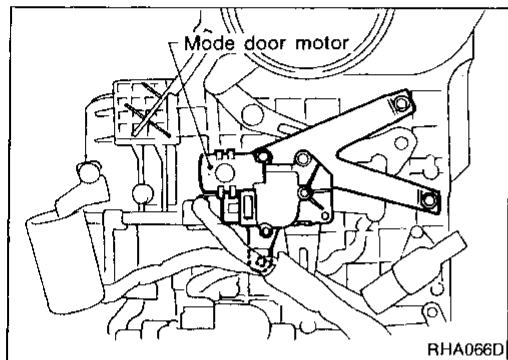

## Control Linkage Adjustment

### MODE DOOR

1. Install mode door motor on heater unit and connect to body harness.
2. Set up "ACTIVE TEST" mode with CONSULT or set up self-diagnosis STEP 4.
3. Set mode door to the following position.

	VENT
	41

4. Move side link by hand and hold mode door in VENT mode.
5. Attach mode door motor rod to side link rod holder.
6. Make sure mode door operates when position is changed with CONSULT or when code is changed from No. 41 to other codes.

	VENT	B/L1	B/L2	F/D1	F/D2	DEF
	41	42	43	44	45	46

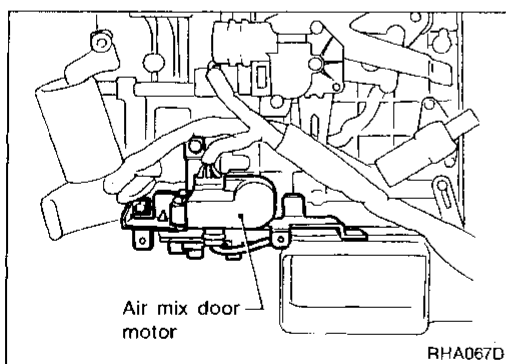

### AIR MIX DOOR

1. Install air mix door motor on heater unit and connect to body harness.
2. Set up "ACTIVE TEST" mode with CONSULT or set up self-diagnosis STEP 4.
3. Set air mix door to the following position.

	FULL/COOL
	41

4. Pull rod A toward driver (FULL COLD) and secure to rod holder.
5. Set air mix door to the following position.

	FULL/HOT
	46

6. Pull rod B toward driver (FULL HOT) and secure to rod holder.

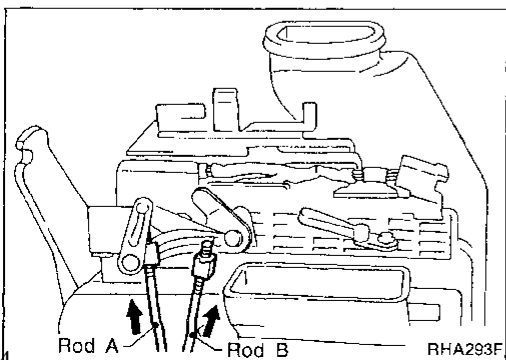

# TROUBLE DIAGNOSES

## Control Linkage Adjustment (Cont'd)

7. Make sure air mix door operates when position is changed with CONSULT or when code is changed from No. 45 to other codes.

	FULL/COOL	FULL/COOL	FULL/HOT	FULL/HOT	FULL/HOT	FULL/HOT	GI
	41	42	43	44	45	46	MA

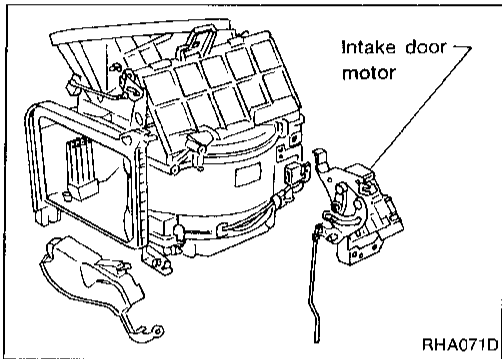

### INTAKE DOOR

1. Install intake door motor on intake unit and connect it to body harness.
2. Set up "ACTIVE TEST" mode with CONSULT or set up self-diagnosis STEP 4.
3. Set intake door to the following position.

	REC	FE
	41	AT

4. Move intake door link by hand and hold it in REC position.
5. Attach intake door lever to rod holder.
6. Make sure intake door operates when position is changed with CONSULT or when code is changed from No. 41 to other codes.

	REC	20% FRE	20% FRE	80% FRE	FRESH	FRESH	RA
	41	42	43	44	45	46	BR

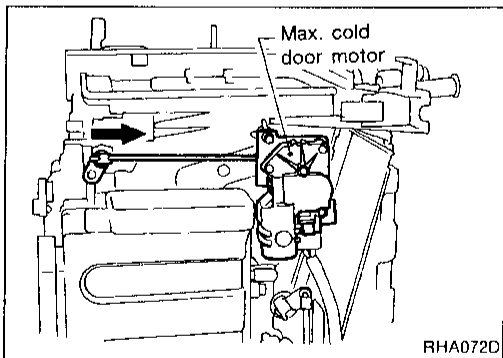

### MAX. COLD DOOR

1. Install max. cold door motor on heater unit and connect to body harness.
2. Set up code No. 41 in self-diagnosis STEP 4.
3. Move max. cold door link by hand and hold it in the shut position.
4. Attach max. cold door lever to rod holder.
5. Make sure max. cold door operates properly when changing from code No. 41 to 42 by pushing DEFROSTER switch.

41	42	43	44	45	46	EL
Shut	Open		Shut			IDX

# SYSTEM DESCRIPTION

## Overview of Control System

The control system consists of a) input sensors and switches, b) the automatic amplifier (microcomputer), and c) outputs. The relationship of these components is shown in the diagram below:

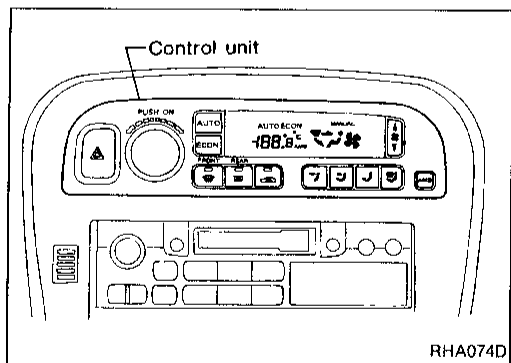
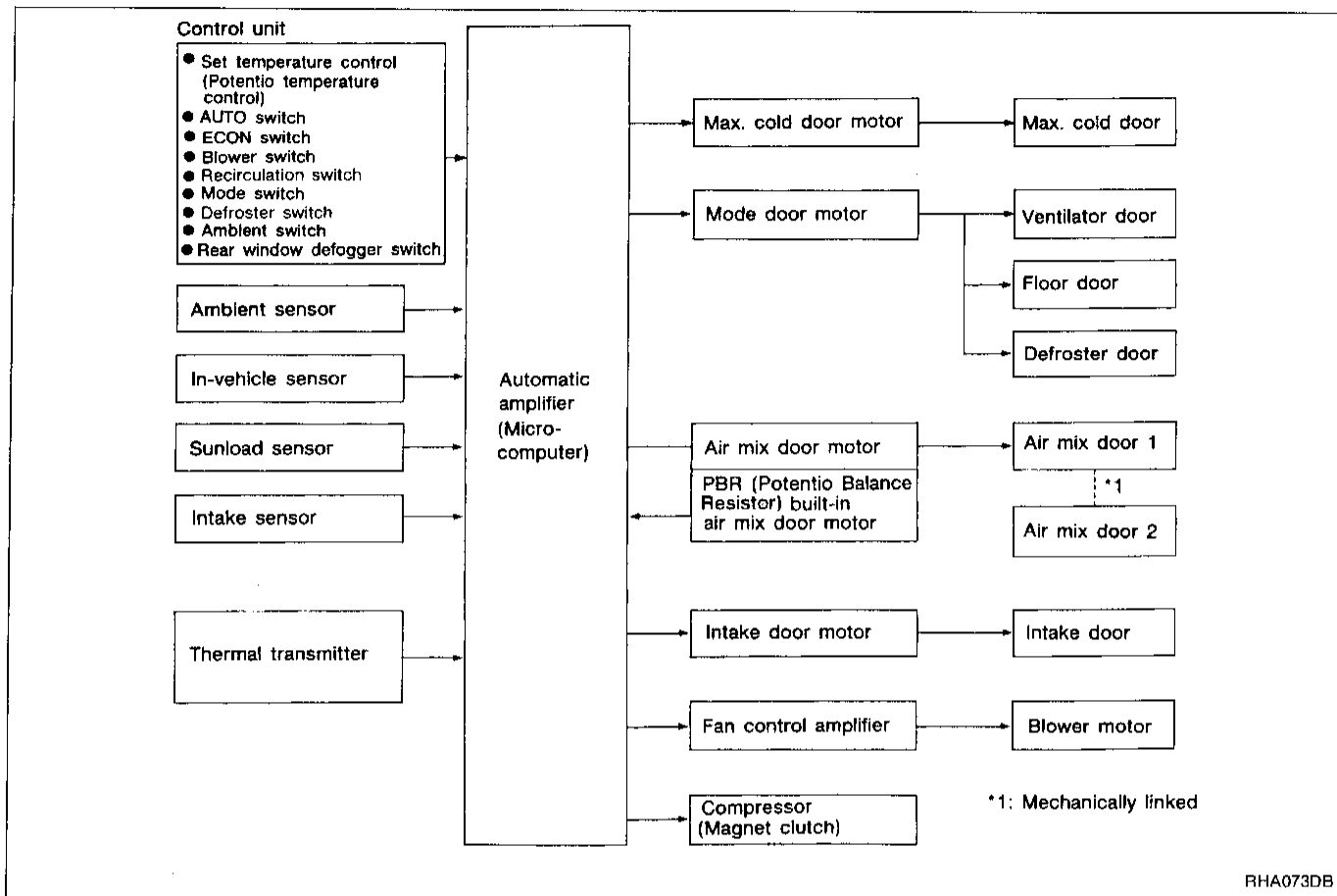

## Control System Input Components

### CONTROL UNIT

By means of multiplex communication, the control unit signals to the auto amp. the switch position and display mode.



# SYSTEM DESCRIPTION

## Control System Input Components (Cont'd)

### POTENTIO TEMPERATURE CONTROL (PTC)

The PTC is built into the auto amplifier. It can be set at intervals of 0.5°C (1.0°F) in the 18°C (65°F) to 32°C (85°F) temperature range by rotating the temperature switch. Setting temperature is digitally displayed.

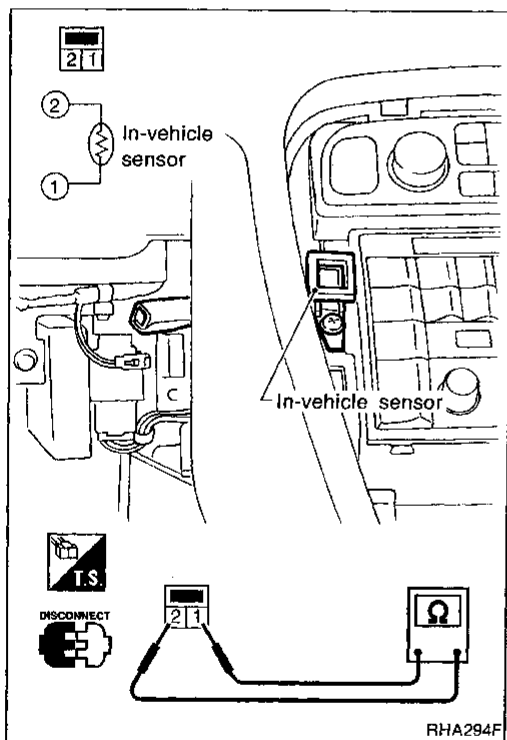
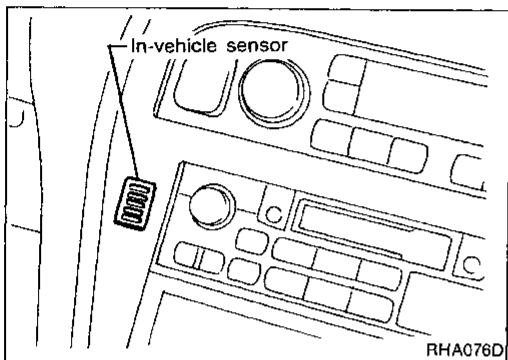
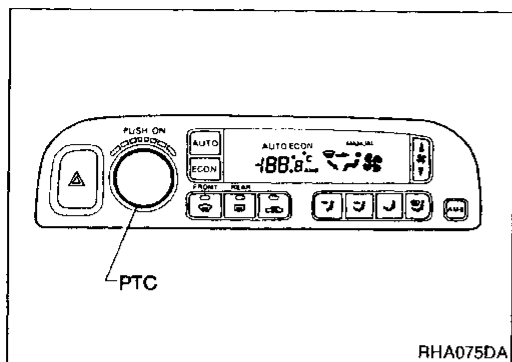

### IN-VEHICLE SENSOR

The in-vehicle sensor is attached to cluster lid C. It converts variations in temperature of compartment air drawn from the aspirator into a resistance value. It is then input into the auto amplifier. (A more detailed description of the aspirator is shown on the following page.)

After disconnecting in-vehicle sensor harness connector, measure resistance between terminals ① and ② at sensor harness side, using the table below.

Temperature °C (°F)	Resistance kΩ
-35 (-31)	38.35
-30 (-22)	28.62
-25 (-13)	21.61
-20 (-4)	16.50
-15 (5)	12.73
-10 (14)	9.92
-5 (23)	7.80
0 (32)	6.19
5 (41)	4.95
10 (50)	3.99
15 (59)	3.24
20 (68)	2.65
25 (77)	2.19
30 (86)	1.81
35 (95)	1.51
40 (104)	1.27
45 (113)	1.07
50 (122)	0.91
55 (131)	0.77
60 (140)	0.66
65 (149)	0.57

GI

MA

EM

LC

EC

FE

AT

PD

FA

RA

BR

ST

RS

BT

HA

EL

IDX

## SYSTEM DESCRIPTION

### Control System Input Components (Cont'd)

#### ASPIRATOR

The aspirator is located below the side link of heater unit. It produces vacuum pressure due to air discharged from the heater unit, continuously taking compartment air in the aspirator.

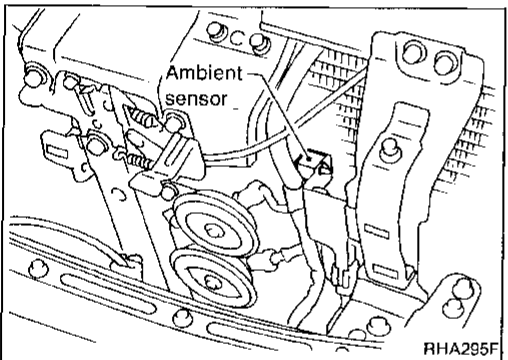
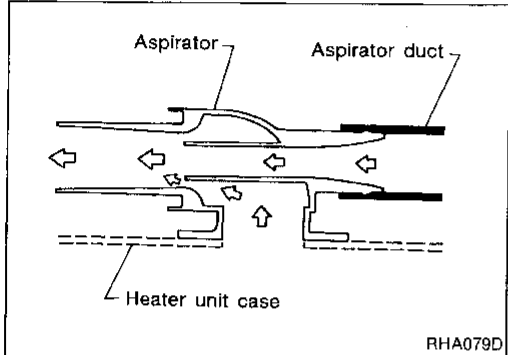
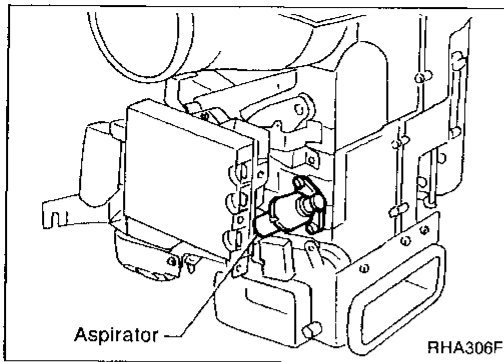

#### AMBIENT SENSOR

The ambient sensor is attached in front of the driver's side condenser. It detects ambient temperature and converts it into a resistance value which is then input to the auto amplifier. After disconnecting ambient sensor harness connector, measure resistance between terminals ① and ② at sensor harness side, using the table below.

Temperature °C (°F)	Resistance kΩ
-35 (-31)	38.35
-30 (-22)	28.62
-25 (-13)	21.61
-20 (-4)	16.50
-15 (5)	12.73
-10 (14)	9.92
-5 (23)	7.80
0 (32)	6.19
5 (41)	4.95
10 (50)	3.99
15 (59)	3.24
20 (68)	2.65
25 (77)	2.19
30 (86)	1.81
35 (95)	1.51
40 (104)	1.27
45 (113)	1.07
50 (122)	0.91
55 (131)	0.77
60 (140)	0.66
65 (149)	0.57

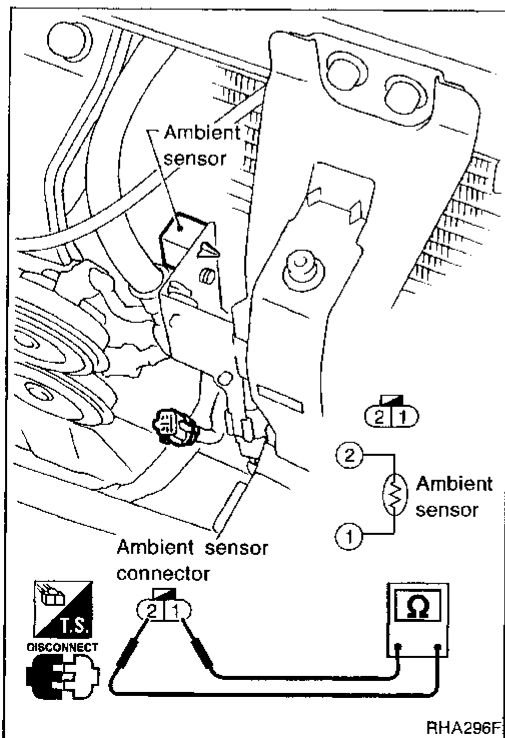

# SYSTEM DESCRIPTION

## Control System Input Components (Cont'd)

### SUNLOAD SENSOR

The sunload sensor is located on the left defroster grille. It detects sunload entering through windshield by means of a photo diode. Then, it converts the sunload into a current value which is input to the auto amplifier.

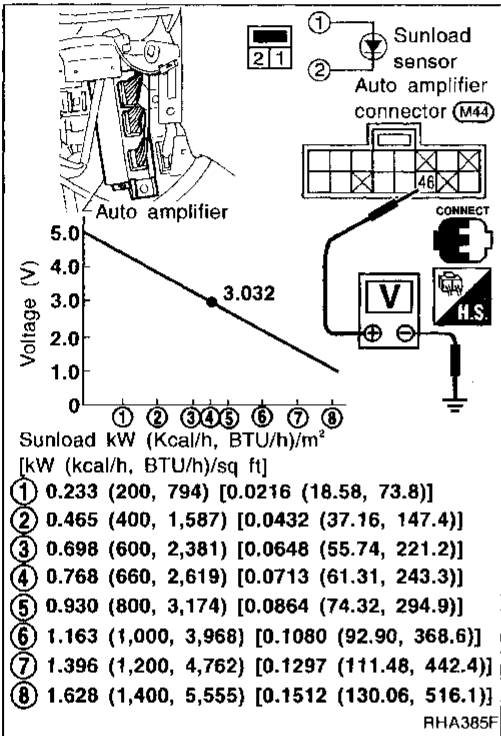
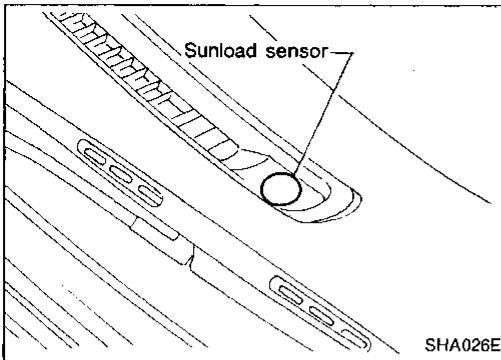

Measure voltage across terminal No. ④⑥ and body ground.

- When checking sunload sensor, select a place where sun shines directly on it.
- Sunload under direct sunlight is equivalent to approximately 0.768 kW (660 kcal/h, 2,619 BTU/h)/m<sup>2</sup> [0.0713 kW (61.31 kcal/h, 243.3 BTU/h)/sq ft].

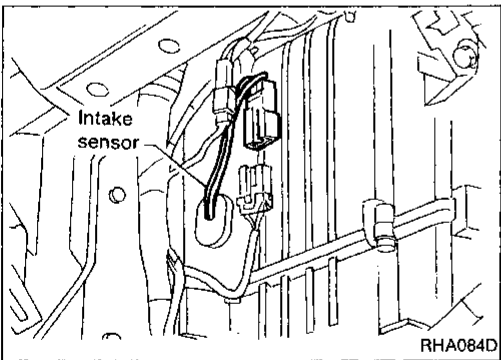

### INTAKE SENSOR

The intake sensor is located on the cooling unit. It converts temperature of air after it passes through the evaporator into a resistance value. The value is then input to the auto amplifier.

GI

MA

EM

LC

EC

FE

AT

PD

FA

RA

BR

ST

RS

BT

HA

EL

IDX

## SYSTEM DESCRIPTION

### Control System Input Components (Cont'd)

After disconnecting intake sensor harness connector, measure resistance between terminals ② and ① at sensor harness side, using the table below.

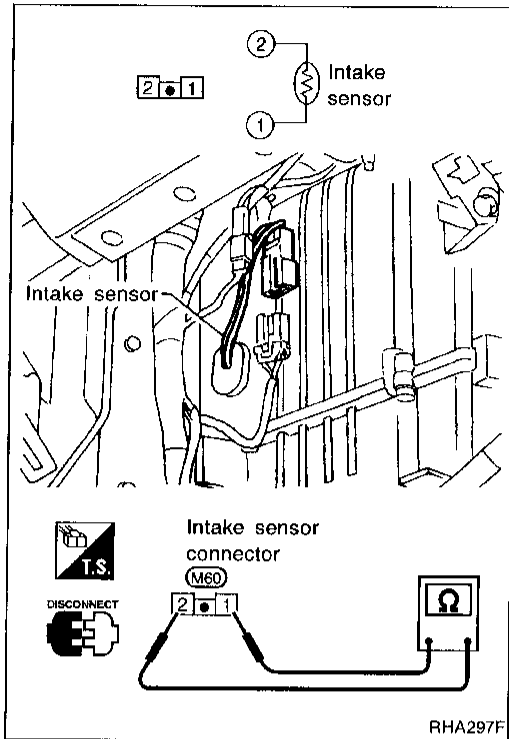

Temperature °C (°F)	Resistance kΩ
-35 (-31)	38.13
-30 (-22)	27.74
-25 (-13)	20.95
-20 (-4)	16.00
-15 (5)	12.34
-10 (14)	9.62
-5 (23)	7.56
0 (32)	6.00
5 (41)	4.80
10 (50)	3.87
15 (59)	3.14
20 (68)	2.57
25 (77)	2.12
30 (86)	1.76
35 (95)	1.47
40 (104)	1.23
45 (113)	1.04
50 (122)	0.88
55 (131)	0.75
60 (140)	0.64
65 (149)	0.55

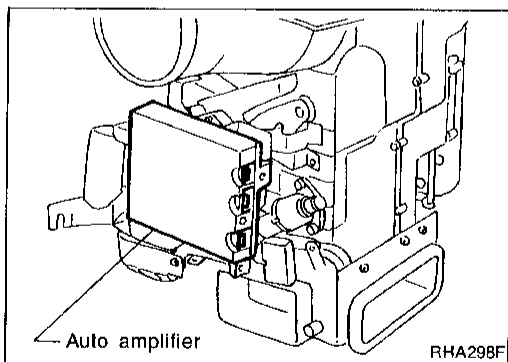

### Control System Automatic Amplifier (Auto amp.)

The auto amplifier has a built-in microcomputer which processes information sent from various sensors needed for air conditioner operation. The air mix door motor, mode door motor, intake door motor, max. cold door motor, blower motor and compressor are then controlled.

The auto amplifier is unitized with control mechanisms. Signals from various switches and Potentio Temperature Control (PTC) are directly entered into auto amplifier.

Self-diagnostic functions are also built into auto amplifier to provide quick check of malfunctions in the auto air conditioner system.

### AMBIENT TEMPERATURE INPUT PROCESS

The automatic amplifier includes a "processing circuit" for the ambient sensor input. When the ambient temperature increases quickly, the processing circuit controls the input from the ambient sensor. It allows the auto amp. to recognize the increase of temperature only 0.33°C (0.6°F) per 100 seconds.

As an example, consider stopping for a cup of coffee after high speed driving. Even though the actual ambient temperature has not changed, the ambient sensor will detect the increase of temperature. The heat radiated from the engine compartment can radiate to the front grille area. The ambient sensor is located there.

## SYSTEM DESCRIPTION

### Control System Automatic Amplifier (Auto amp.) (Cont'd)

#### SUNLOAD INPUT PROCESS

The auto amp. also includes a processing circuit which "average" the variations in detected sunload over a period of time. This prevents drastic swings in the ATC system operation due to small or quick variations in detected sunload.

For example, consider driving along a road bordered by an occasional group of large trees. The sunload detected by the sunload sensor will vary whenever the trees obstruct the sunlight. The processing circuit averages the detected sunload over a period of time. As a result, the above-mentioned effect does not cause any change in the ATC system operation. On the other hand, shortly after entering a long tunnel, the system will recognize the change in sunload, and the system will react accordingly.

GI

MA

EM

LC

EC

FE

AT

PD

FA

RA

BR

ST

RS

BT

HA

EL

IDX

## Control System Output Components

### AIR MIX DOOR CONTROL (Automatic temperature control)

#### Component parts

Air mix door control system components are:

- 1) Auto amplifier
- 2) Control unit (PTC)
- 3) Air mix door motor (PBR)
- 4) In-vehicle sensor
- 5) Ambient sensor
- 6) Sunload sensor
- 7) Intake sensor

#### System operation

Temperature set by Potentio Temperature Control (PTC) is compensated through setting temperature correction circuit to determine target temperature.

Auto amplifier will operate air mix door motor to set air conditioning system in HOT or COLD position, depending upon relationship between conditions (target temperature, sunload, in-vehicle temperature and ambient temperature) and conditions (air mix door position and intake air temperature).

When set temperature is 18°C (65°F), air mix door motor will be in the FULL COLD position; when set temperature is 32°C (85°F), motor will be in the FULL HOT position.

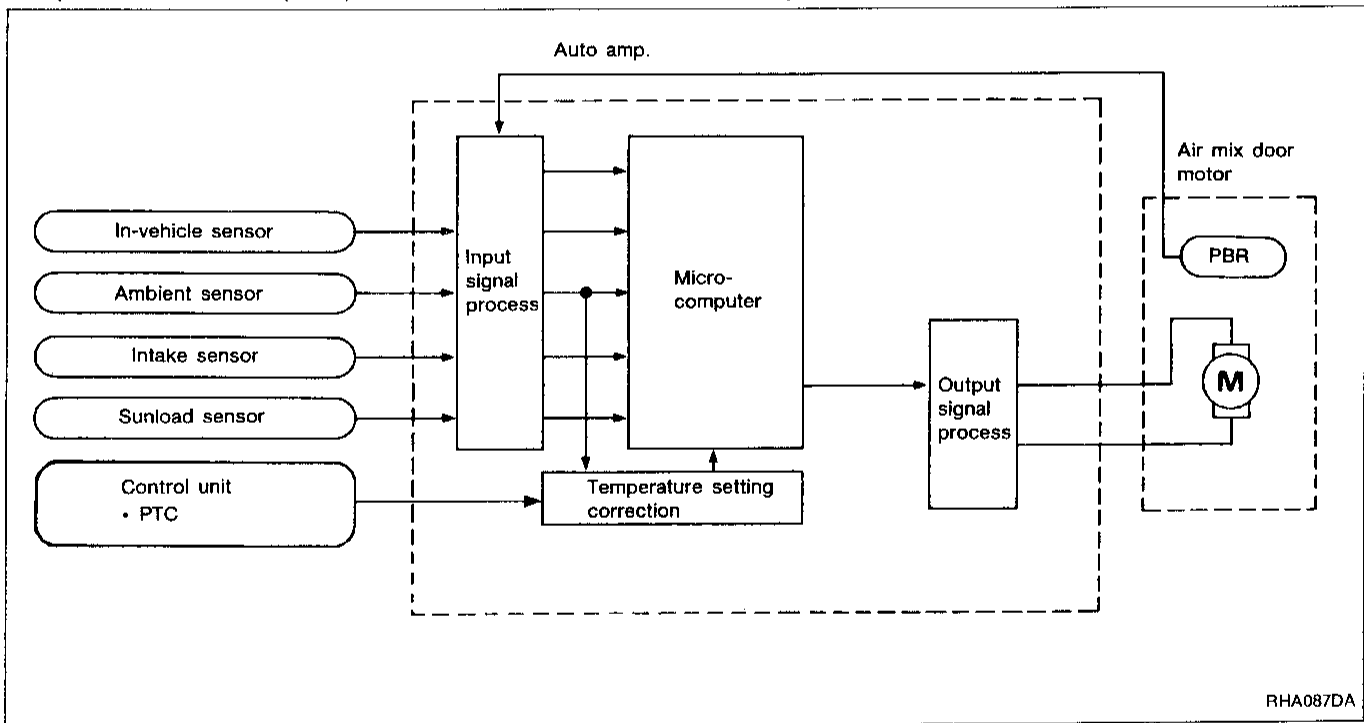

# SYSTEM DESCRIPTION

## Control System Output Components (Cont'd) Air mix door control specification

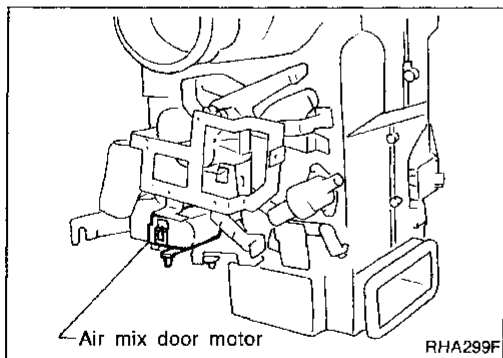
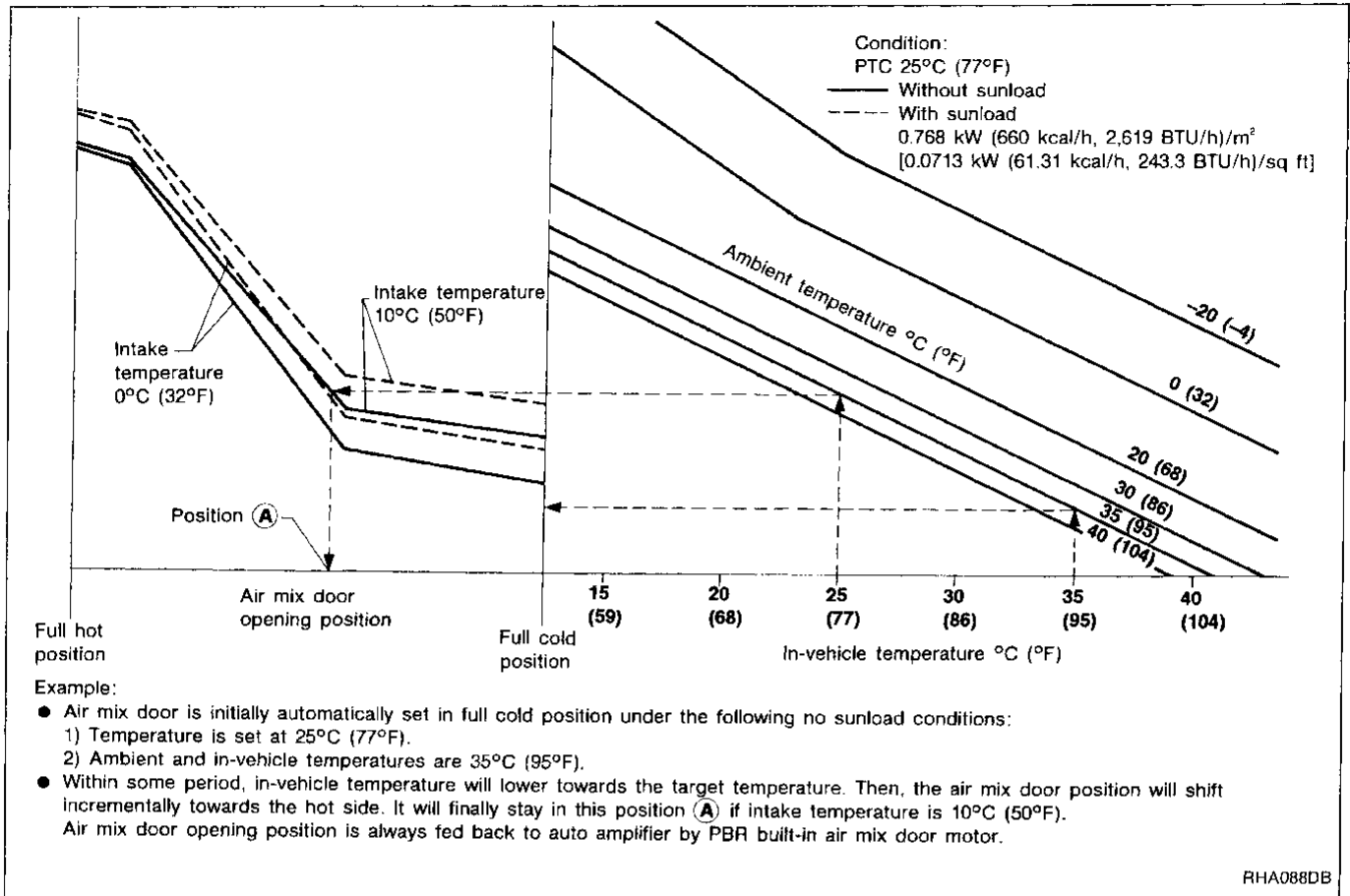

### AIR MIX DOOR MOTOR

The air mix door motor is attached to the heater unit. It rotates so that the air mix door is opened to a position set by the auto amplifier. Motor rotation is then conveyed through a shaft. Air mix door position is then fed back to the auto amplifier by PBR built-in air mix door motor.

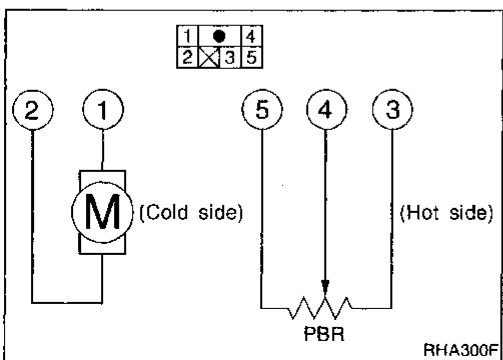

### Air mix door motor operation

2	1	Air mix door operation	Direction of lever movement	Voltage V
⊕	⊖	COLD → HOT	Clockwise (Downward)	Approx. 10.5
—	—	STOP	STOP	Less than approx. 1.5
⊖	⊕	HOT → COLD	Counterclockwise (Upward)	Approx. 10.5

# SYSTEM DESCRIPTION

## Control System Output Components (Cont'd)

### PBR characteristics

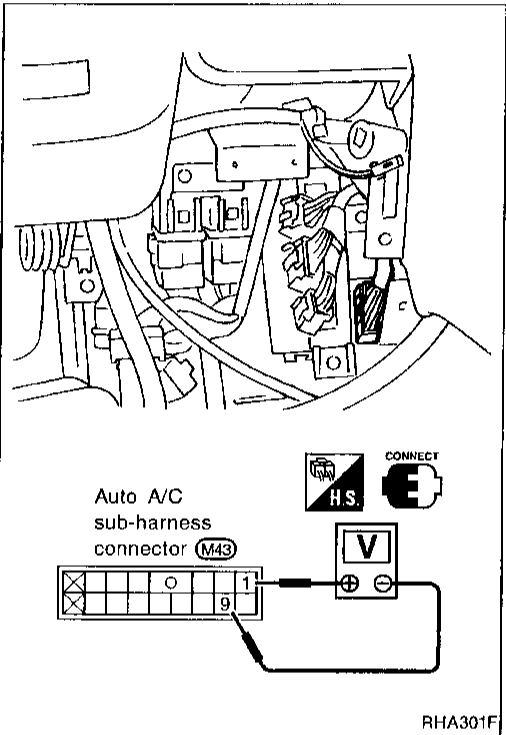
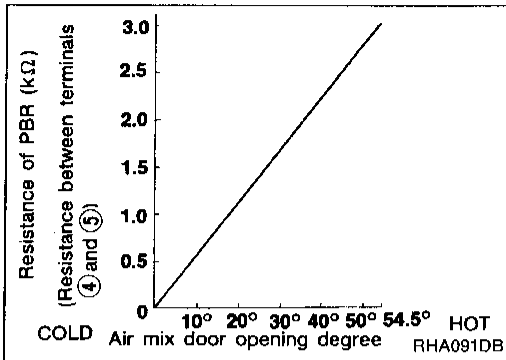

### PBR

Measure voltage between terminals ① and ⑨ at vehicle harness side.

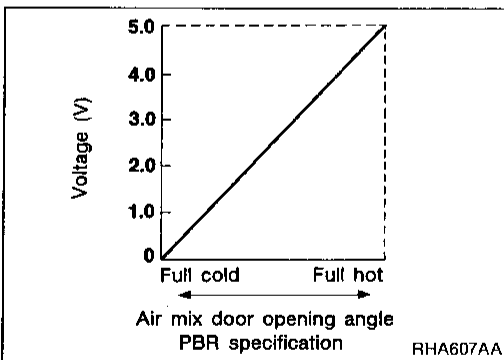

### Ignition switch: ON

- Ensure tester pointer deflects smoothly when PTC is moved from 18°C (65°F) to 32°C (85°F) and vice versa.



# SYSTEM DESCRIPTION

## Control System Output Components (Cont'd)

### MAX. COLD DOOR CONTROL

#### Component parts

Max. cold door control system components are:

- 1) Auto amplifier
- 2) Max. cold door motor
- 3) Control unit (PTC)
- 4) Air mix door motor (PBR)
- 5) In-vehicle sensor
- 6) Ambient sensor
- 7) Sunload sensor
- 8) Intake sensor

#### System operation

The auto amplifier will activate the max. cold door motor and open it when the air outlets are set to the B/L position. It will also activate when the air mix door is set to the "FULL COLD" position with air outlets set to VENT. In all other modes the max. cold door is closed.

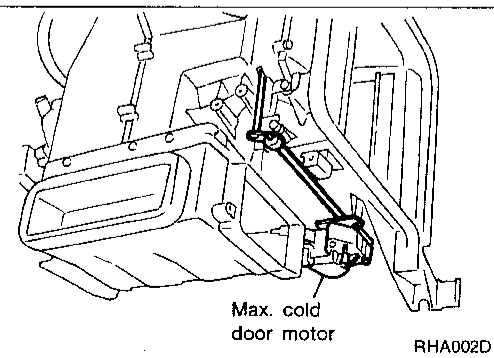
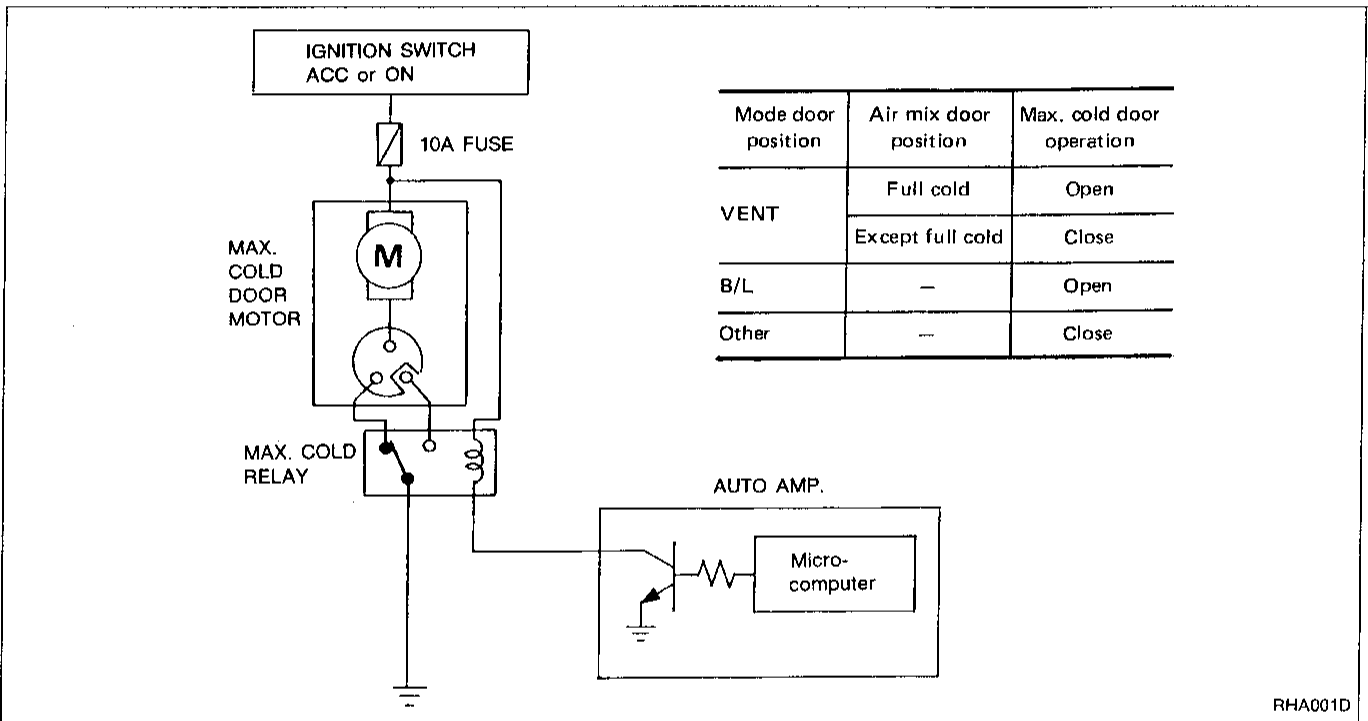

#### MAX. COLD DOOR MOTOR

The max. cold door motor is attached to the heater unit. It rotates so that the max. cold door is opened to the position set by the auto amplifier.

Motor rotation is conveyed to a link which activates the max. cold door.

GI

WA

EM

LC

EC

FE

AT

PD

FA

RA

BR

ST

RS

BT

HA

EL

IDX

# SYSTEM DESCRIPTION

## Control System Output Components (Cont'd)

### OUTLET DOOR CONTROL

#### Component parts

Outlet door control system components are:

- 1) Auto amplifier
- 2) Control unit (PTC, and AUTO, ECON, MODE, DEF switches)
- 3) Mode door motor
- 4) PBR
- 5) In-vehicle sensor
- 6) Ambient sensor
- 7) Sunload sensor
- 8) Intake sensor

#### System operation

The auto amplifier computes the air outlet conditions according to the ambient temperature and the in-vehicle temperature. The computed outlet conditions are then corrected for sunload to determine air outlet. The determined amount of air is discharged into the passenger compartment.

When the air outlet is automatically selected as FOOT/DEF, the actual outlet will be either F/D1 or F/D2. It will depend on the target temperature and the ambient temperature.

When the OFF switch is pushed, the auto amplifier sets the mode door at the "F/D 1" position.

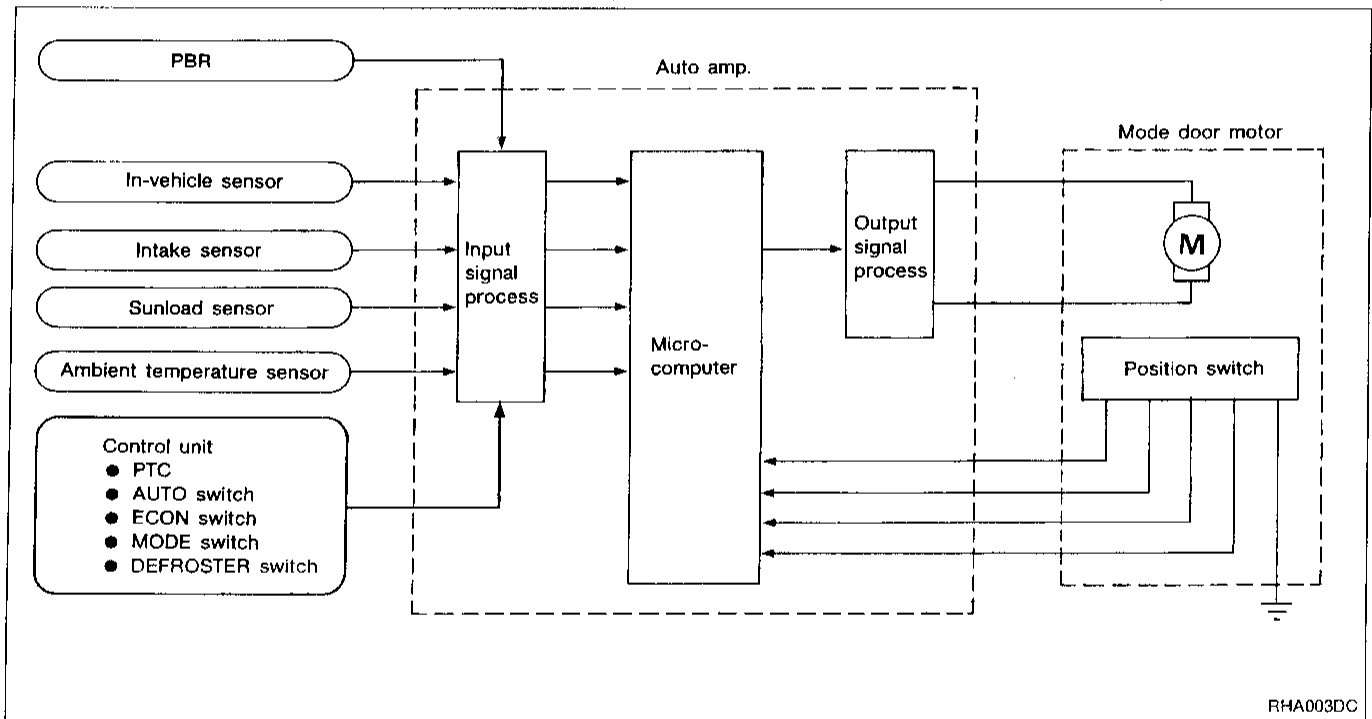

# SYSTEM DESCRIPTION

## Control System Output Components (Cont'd) Outlet door control specification

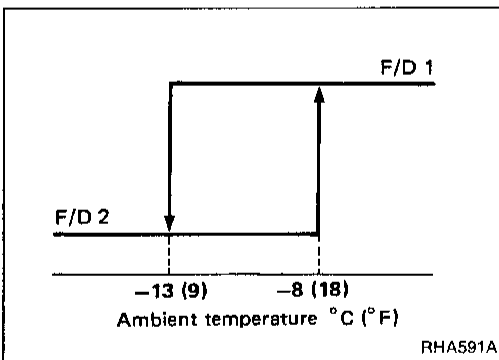
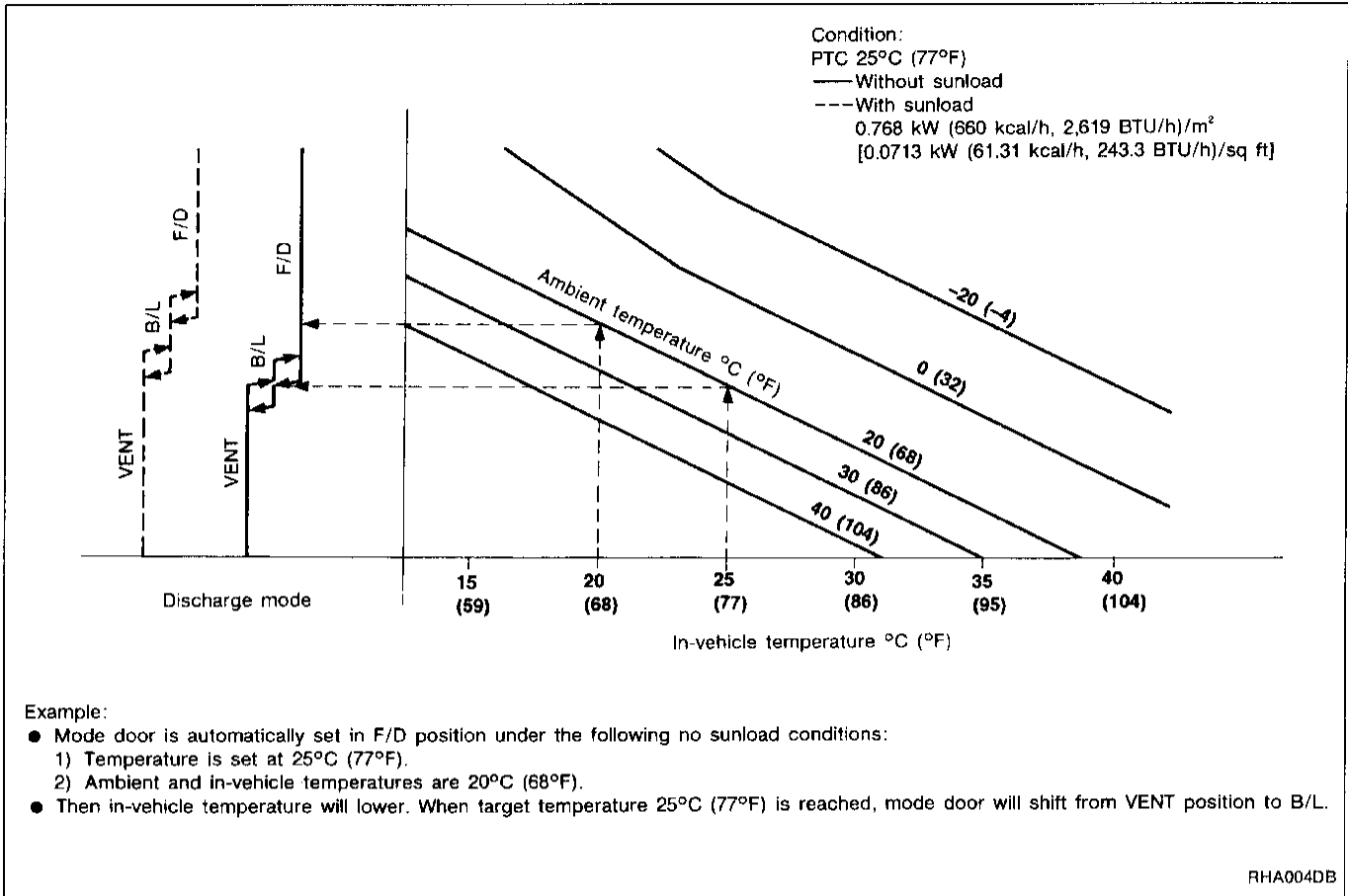

### FOOT/DEF mode specification

- When the air outlet is automatically selected as F/D, when target temperature is high, the air outlet is fixed at F/D 1.
- When the target temperature is low, the air outlet will be either F/D 1 or F/D 2 depending on the ambient temperature.
- When the ambient temperature decreases to -13°C (9°F), air outlet is changed from F/D1 to F/D2.
- When the ambient temperature increases to -8°C (18°F), air outlet is changed from F/D2 to F/D1.

GI  
 MA  
 EM  
 LC  
 EC  
 FE  
 AT  
 PD  
 FA  
 RA  
 BR  
 ST  
 RS  
 BT  
 HA  
 EL  
 IDX

# SYSTEM DESCRIPTION

## Control System Output Components (Cont'd)

### MODE DOOR MOTOR

The mode door motor is attached to the heater unit. It rotates so that air is discharged from outlet set by the auto amplifier. Motor rotation is conveyed to a link which activates the mode door.

### Mode door motor operation

7	8	Mode door operation	Direction of side link rotation	Voltage V
⊕	⊖	VENT → DEF	Counterclockwise	Approx. 10.5
—	—	STOP	STOP	Less than approx. 1.5
⊖	⊕	DEF → VENT	Clockwise	Approx. 10.5

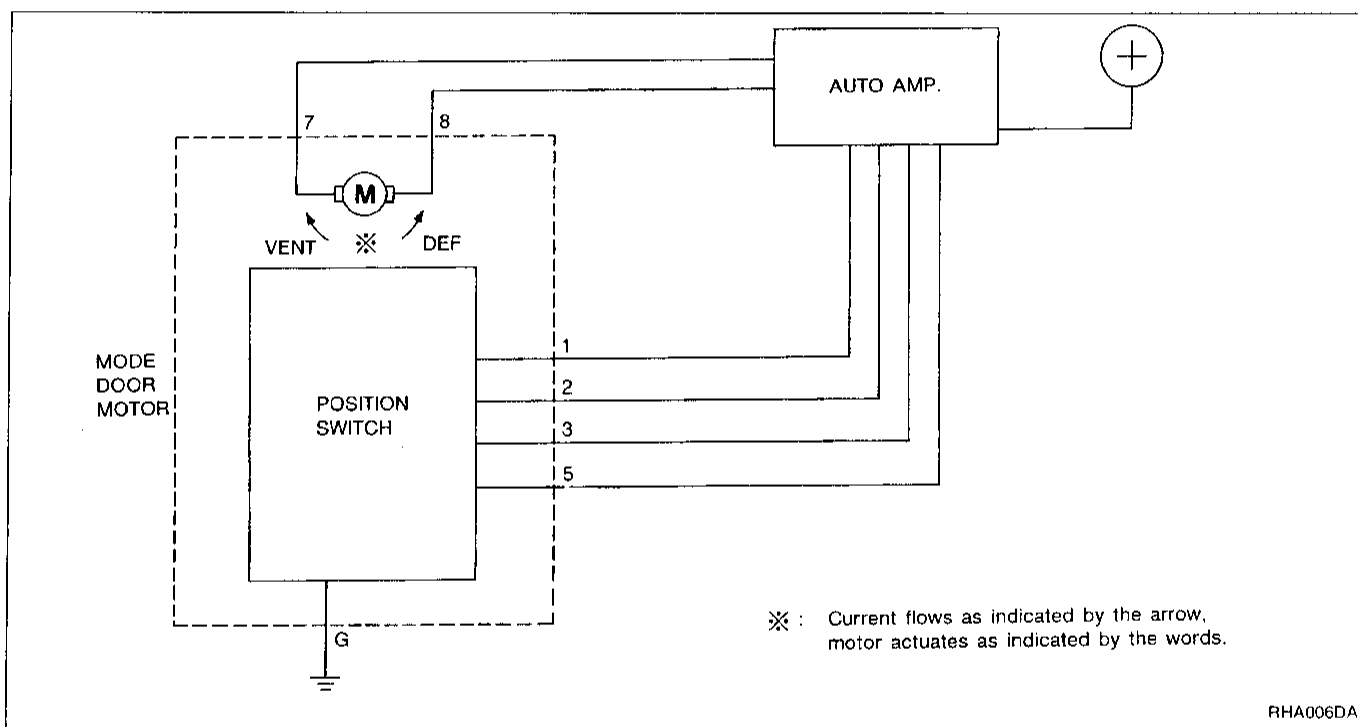
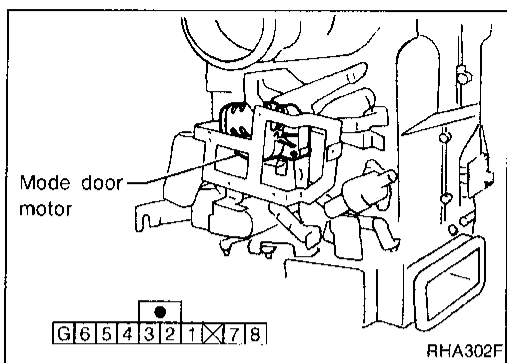

RHA006DA

# SYSTEM DESCRIPTION

## Control System Output Components (Cont'd)

### INTAKE DOOR CONTROL

#### Components parts

Intake door control system components are:

- 1) Auto amplifier
- 2) Control unit (PTC, AUTO, ECON, DEFROSTER, RECIRCULATION switches)
- 3) Intake door motor
- 4) PBR
- 5) In-vehicle sensor
- 6) Ambient sensor
- 7) Sunload sensor
- 8) Intake sensor

#### System operation

The intake door control determines the intake door position based on both ambient and in-vehicle temperature. When the ECON, DEFROSTER, or OFF switches are pushed, the auto amplifier sets the intake door at the "Fresh" position. When the compressor is turned OFF from ON (to prevent the auto amplifier from becoming frozen), the intake door is automatically changed to the "Fresh" position (even if it has been set at the "RECIRCULATION" position).

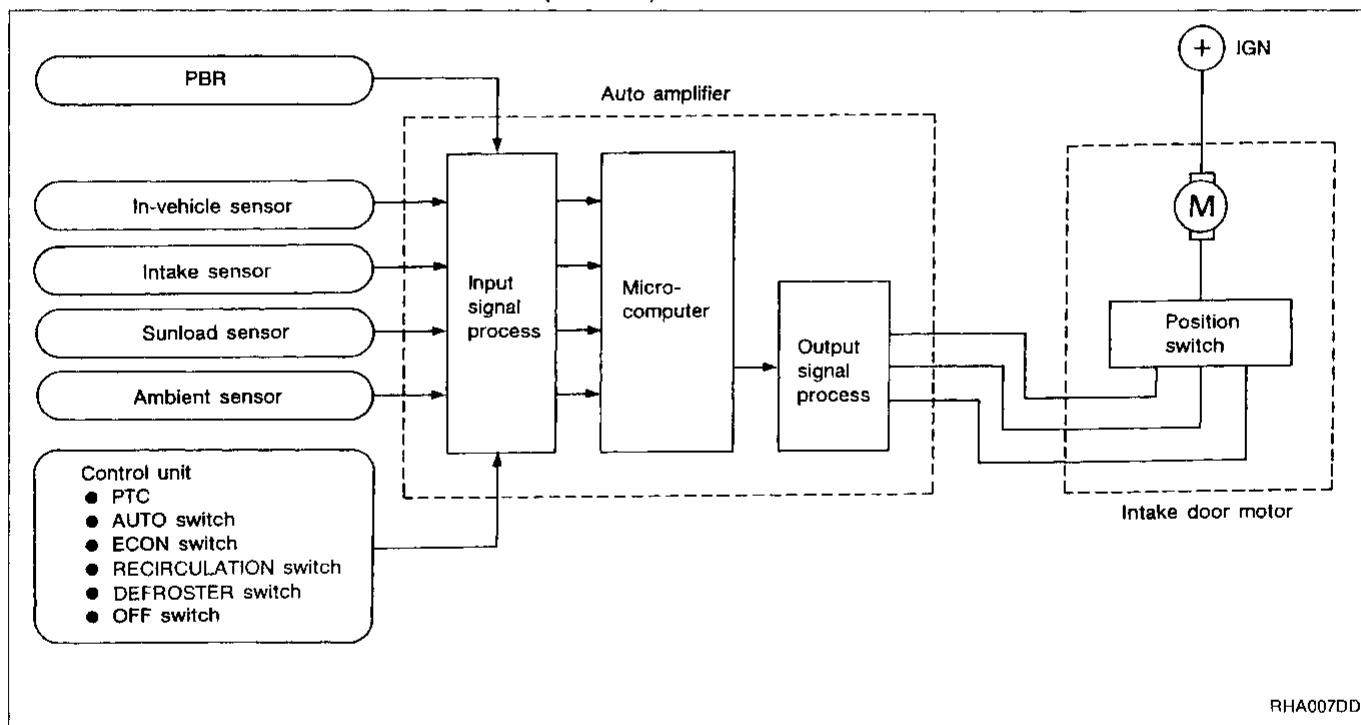

GI

MA

EW

LC

EC

FE

AT

PD

FA

RA

BR

ST

RS

BT

HA

EL

IDX

# SYSTEM DESCRIPTION

## Control System Output Components (Cont'd)

### Intake door control specification

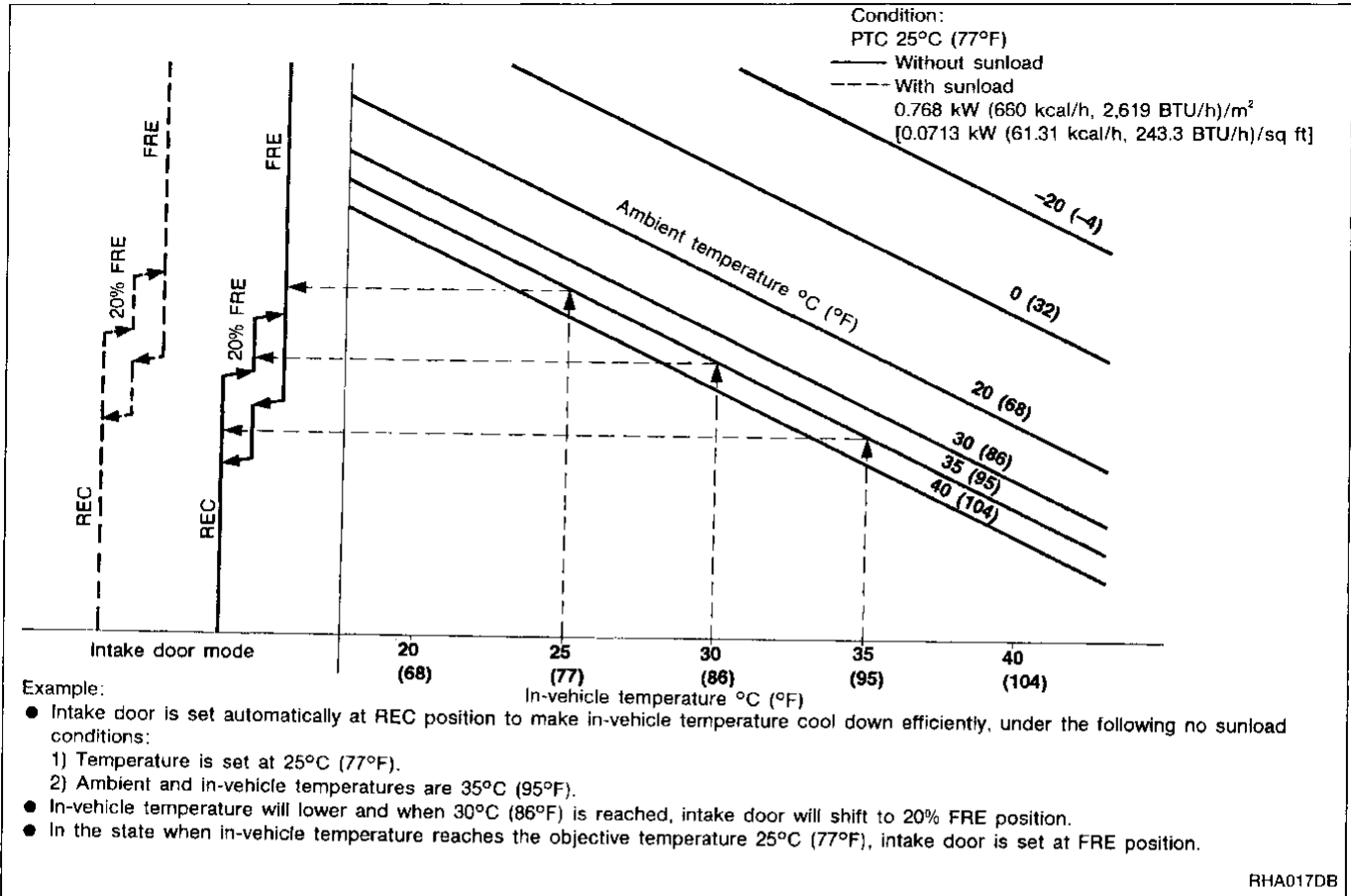

RHA017DB

# SYSTEM DESCRIPTION

## Control System Output Components (Cont'd)

### INTAKE DOOR MOTOR

The intake door motor is attached to the intake unit. It rotates so that air is drawn from inlets set by the auto amplifier. Motor rotation is conveyed to a lever which activates the intake door.

#### Intake door motor operation

2	1	Intake door operation	Movement of side link rotation	Voltage V
⊕	⊖	FRE → REC	Counterclockwise	Approx. 10.5
—	—	STOP	STOP	Less than approx. 1.5
⊖	⊕	REC → FRE	Clockwise	Approx. 10.5

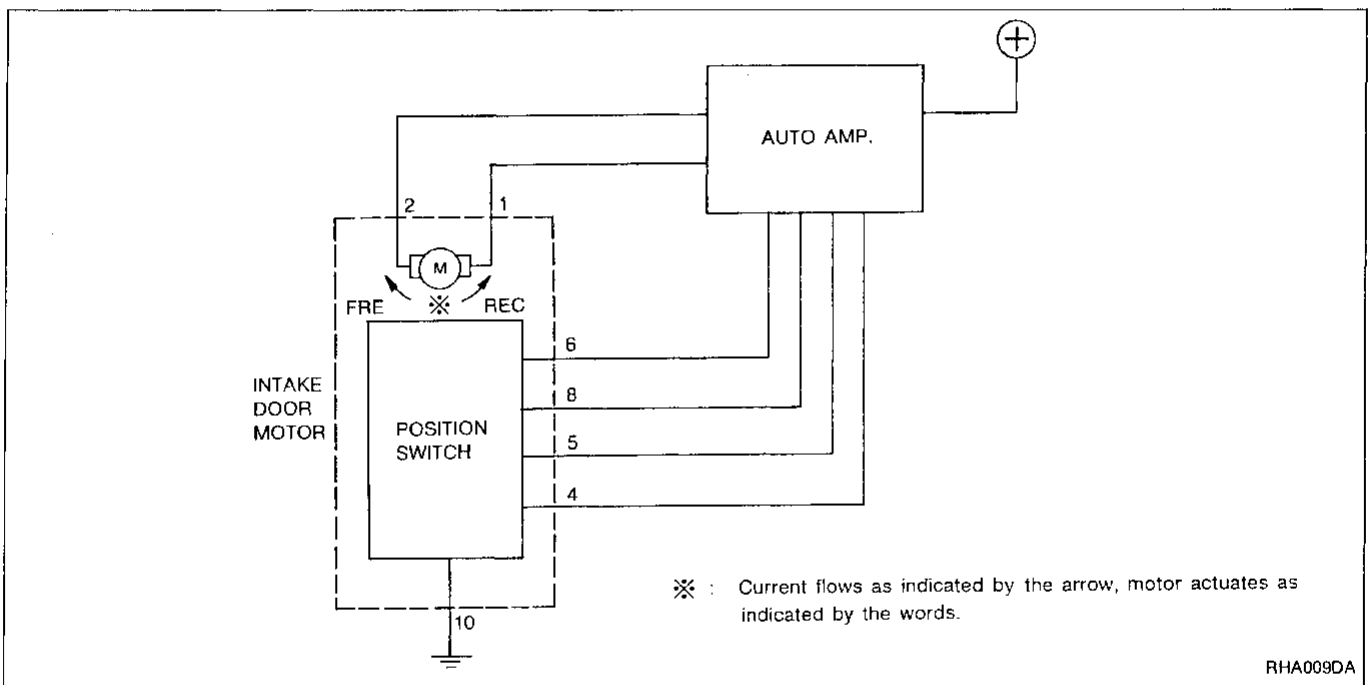
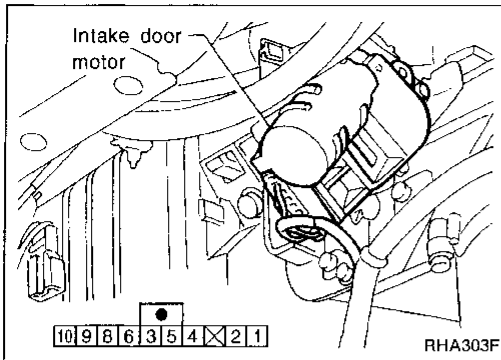

GI  
MA  
EM  
LC  
EC  
FE  
AT  
PD  
FA  
RA  
BR  
ST  
RS  
BT  
HA  
EL  
IDX

# SYSTEM DESCRIPTION

## Control System Output Components (Cont'd)

### FAN SPEED CONTROL

#### Component parts

Fan speed control system components are:

- 1) Auto amplifier
- 2) Control unit  
(PTC, AUTO, ECON, MODE, DEFROSTER, FAN, OFF switches)
- 3) Fan control amplifier
- 4) PBR
- 5) In-vehicle sensor
- 6) Ambient sensor
- 7) Sunload sensor
- 8) Intake sensor
- 9) Hi relay
- 10) Thermal transmitter

#### System operation

For description of system operation, see next page.

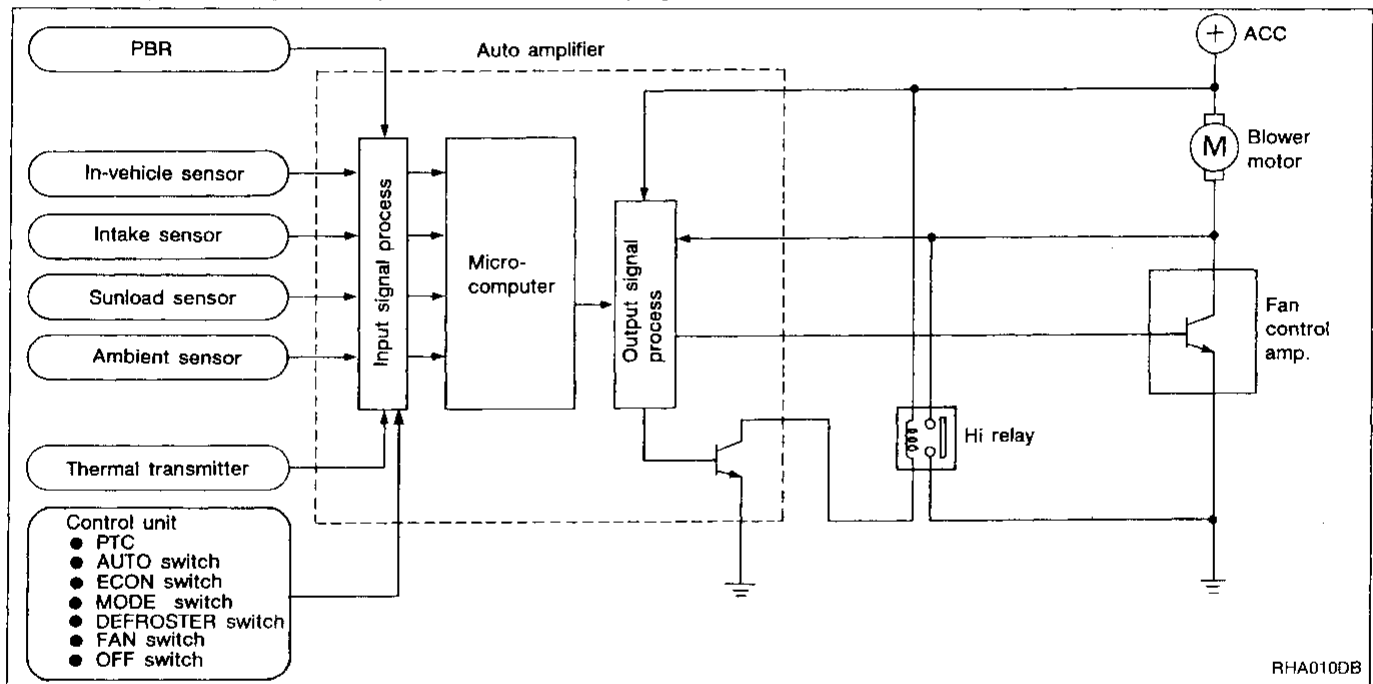



## SYSTEM DESCRIPTION

### Control System Output Components (Cont'd)

#### AUTOMATIC MODE

In the automatic mode, the blower motor speed is calculated by the automatic amplifier based on inputs from the PBR, in-vehicle sensor, sunload sensor, and ambient sensor. The blower motor applied voltage ranges from approximately 5 volts (lowest speed) to 12 volts (highest speed).

The control blower speed (in the range of 5 to 10.5V), the automatic amplifier supplies a signal to the fan control amplifier. Based on this signal, the fan control amplifier controls the current flow from the blower motor to ground. If the computed blower voltage (from automatic amplifier) is above 10.5 volts, the high blower relay is activated. The high blower relay provides a direct path to ground (bypassing the fan control amplifier), and the blower motor operates at high speed.

GI

MA

#### STARTING BLOWER SPEED CONTROL

EM

##### Start up from "COLD SOAK" condition (Automatic mode)

In a cold start-up in the following conditions the blower will not operate for a short period of time (up to 150 seconds): 1) Engine temperature is below 50°C (122°F), 2) Air outlet has been automatically set to B/L or FOOT/DEF. The exact start delay time varies depending on the outlet door control and engine temperature.

LC

EC

In the most extreme case (very low ambient) the blower starting delay will be 150 seconds as described above. After this delay, the blower will operate at low speed until the engine temperature rises above 50°C (122°F). From this point the blower speed will increase to the target speed.

FE

##### Start up from normal or "HOT SOAK" condition (Automatic mode)

AT

The blower will begin operation momentarily after the AUTO button is pushed. The blower speed will gradually rise to the objective speed over a time period of 5 seconds or less (actual time depends on the objective blower speed).

PD

The blower will stop for 3 seconds after it has started with the compressor coming ON at a recirculating air temperature greater than 35°C (95°F).

FA

#### BLOWER SPEED COMPENSATION

RA

##### Sunload

When the in-vehicle temperature and the set temperature are very close, the blower will be operating at low speed. The low speed will vary depending on the sunload. During conditions of high sunload, the blower low speed is "normal" low speed (approx. 6V). During low or no sunload conditions, the low speed will drop to "low" low speed (approx. 5V).

BR

ST

##### Ambient

When the ambient temperature is in the "moderate" range [10 – 15°C (50 - 59°F)], the computed blower voltage will be compensated (reduced) by up to 3.5V (depending on the blower speed). In the "extreme" ambient ranges [below 0°C (32°F) and above 20°C (68°F)] the computed objective blower voltage is not compensated at all. In the ambient temperature ranges between "moderate" and "extreme" [0 - 10°C (32 - 50°F) and 15 - 20°C (59 - 68°F)], the amount of compensation (for a given blower speed) varies depending on the ambient temperature.

RS

BT

HA

EL

IDX

## SYSTEM DESCRIPTION

### Control System Output Components (Cont'd)

#### On-coming air

With intake position at "FRESH" while driving at speeds exceeding 80 km/h (50 MPH), blower motor voltage will lower to a minimum 1.5 volts. This is to prevent an abrupt increase in airflow due to ram pressure.

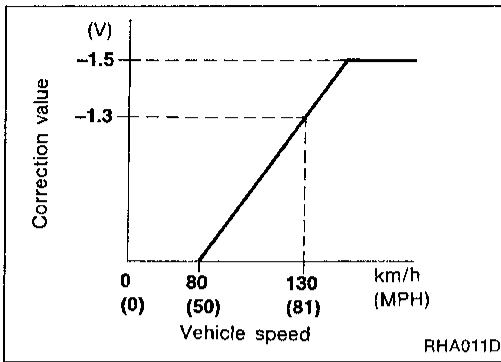

#### Mode

If the mode door motor starts up when the blower motor voltage exceeds 8.5 volts, the auto amplifier will lower the voltage to 8.5 volts.

### Fan speed control specification

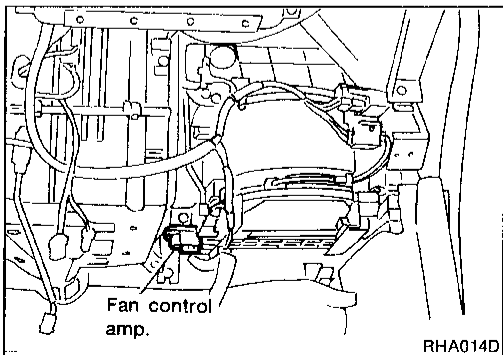
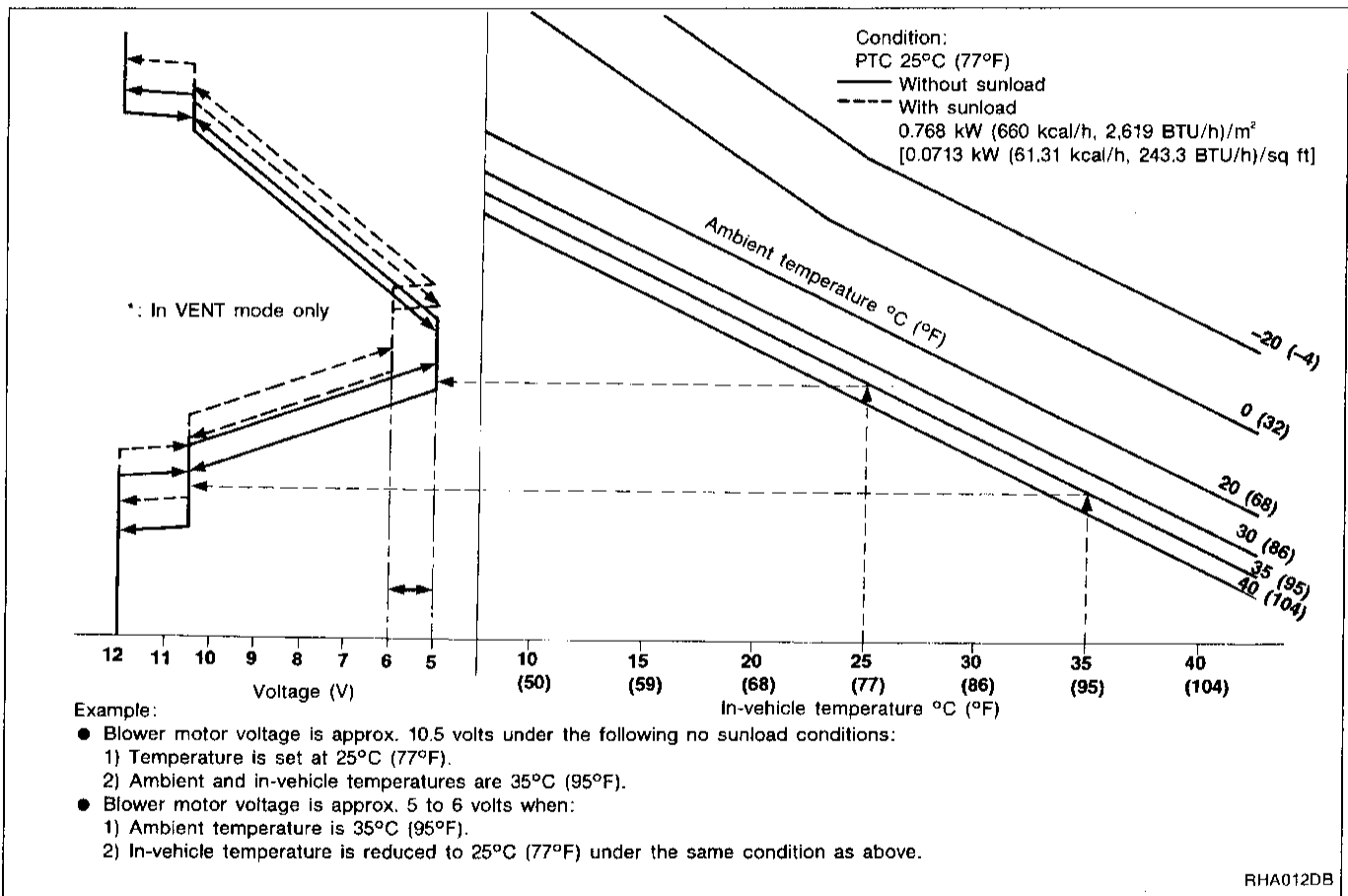

### FAN CONTROL AMPLIFIER

The fan control amplifier is installed on the intake unit. It amplifies the base current of the auto amplifier and controls the blower fan motor speed.

# SYSTEM DESCRIPTION

## Control System Output Components (Cont'd)

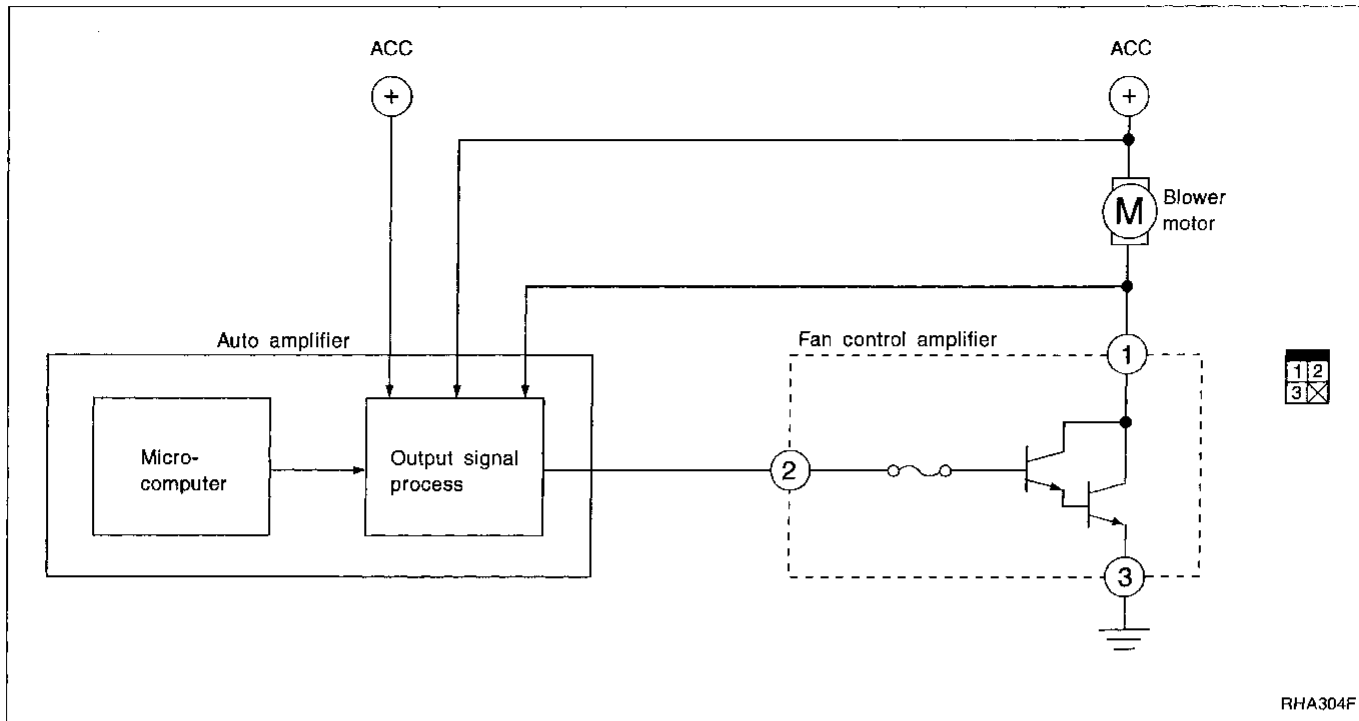

GI

MA

EM

LC

EC

FE

AT

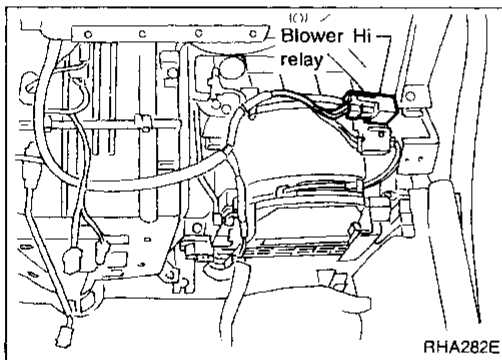

### HI RELAY

The Hi relay is located on the intake unit. It receives a signal from the auto amplifier to operate the blower motor at high speed.

PD

FA

RA

BR

### MAGNET CLUTCH CONTROL

Auto amplifier controls compressor operation by ambient temperature, intake temperature, and signal from ECCS control module.

ST

RS

BT

HA

EL

IDX

## SYSTEM DESCRIPTION

### Control System Output Components (Cont'd)

#### Low temperature protection control

Auto amplifier will turn the compressor "ON" or "OFF" as determined by a signal detected by ambient temperature sensor and intake sensor.

When ambient temperatures are greater than 12°C (54°F), the compressor turns "ON". The compressor turns "OFF" when ambient temperatures are less than -7°C (19°F).

Between the ambient temperatures 12°C (54°F) and -7°C (19°F), the auto amplifier controls the compressor ON-OFF operation as determined by a signal from the intake sensor.

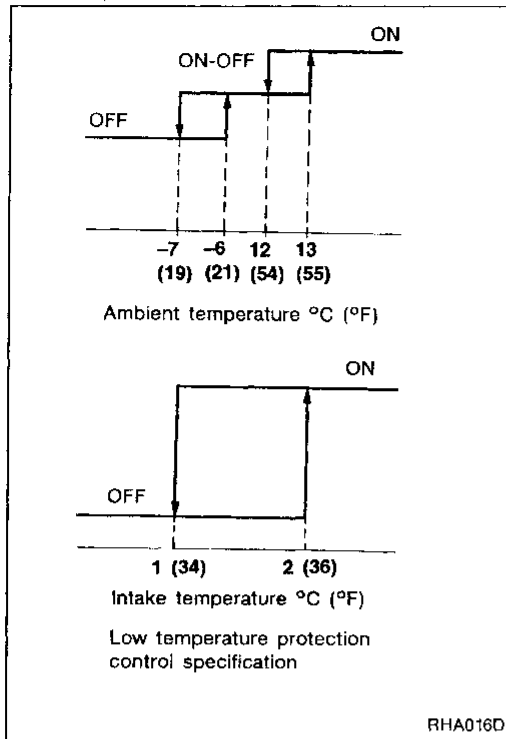

#### Acceleration cut control

The ECCS control module will turn the compressor "ON" or "OFF" based on the signal from the throttle sensor and vehicle speed sensor.

# SERVICE PROCEDURES

## HFC-134a (R-134a) Service Procedure

### SETTING OF SERVICE TOOLS AND EQUIPMENT

#### DISCHARGING REFRIGERANT

##### WARNING:

Avoid breathing A/C refrigerant and lubrication oil vapor or mist. Exposure may irritate eyes, nose and throat. Remove R-134a from A/C system, using certified service equipment meeting requirements of SAE J2210 (R-134a recycling equipment), or J2209 (R-134a recovery equipment). If accidental system discharge occurs, ventilate work area before resuming work.

Additional health and safety information may be obtained from refrigerant and lubricant manufacturers.

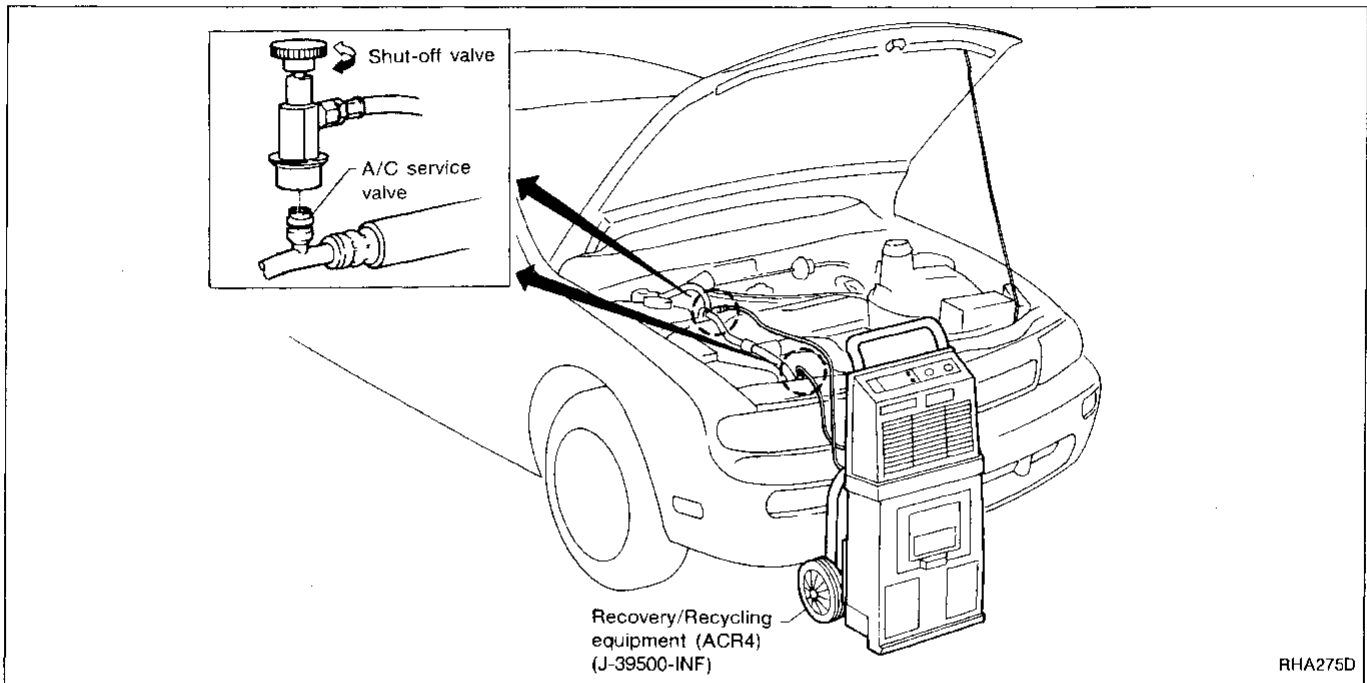

#### EVACUATING SYSTEM AND CHARGING REFRIGERANT

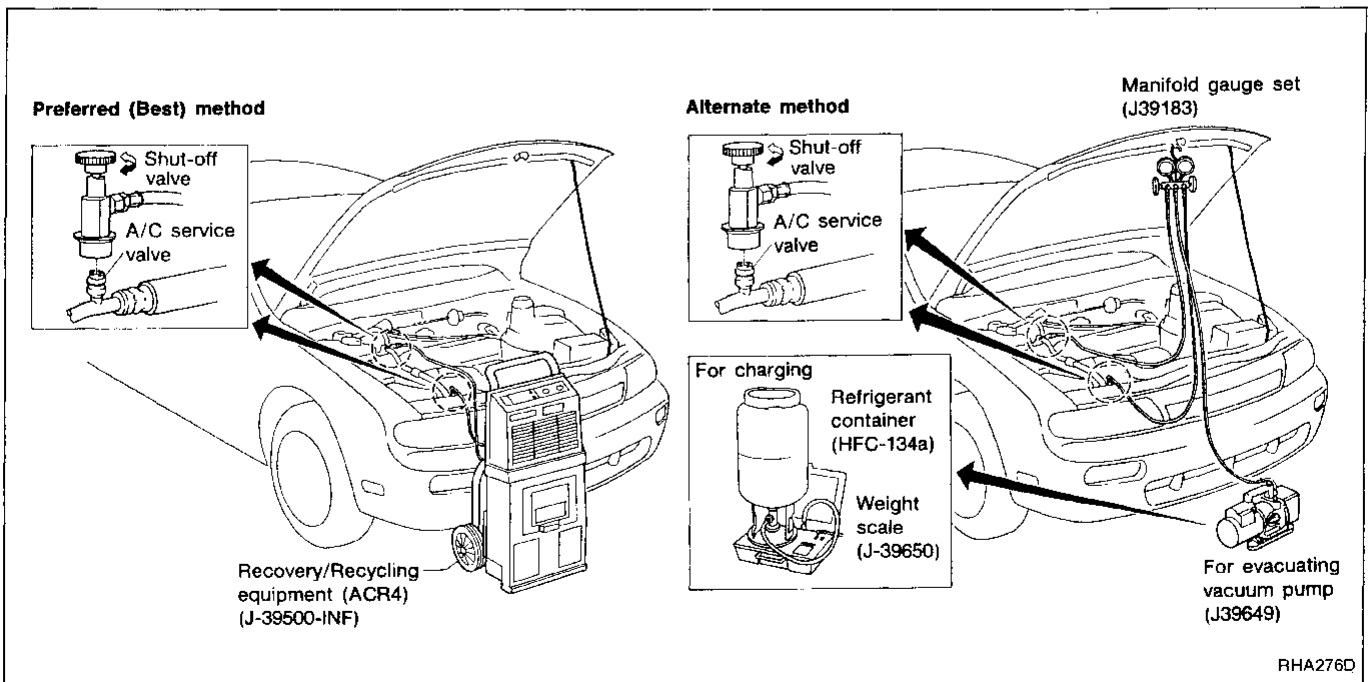

# SERVICE PROCEDURES

## HFC-134a (R-134a) Service Procedure (Cont'd)

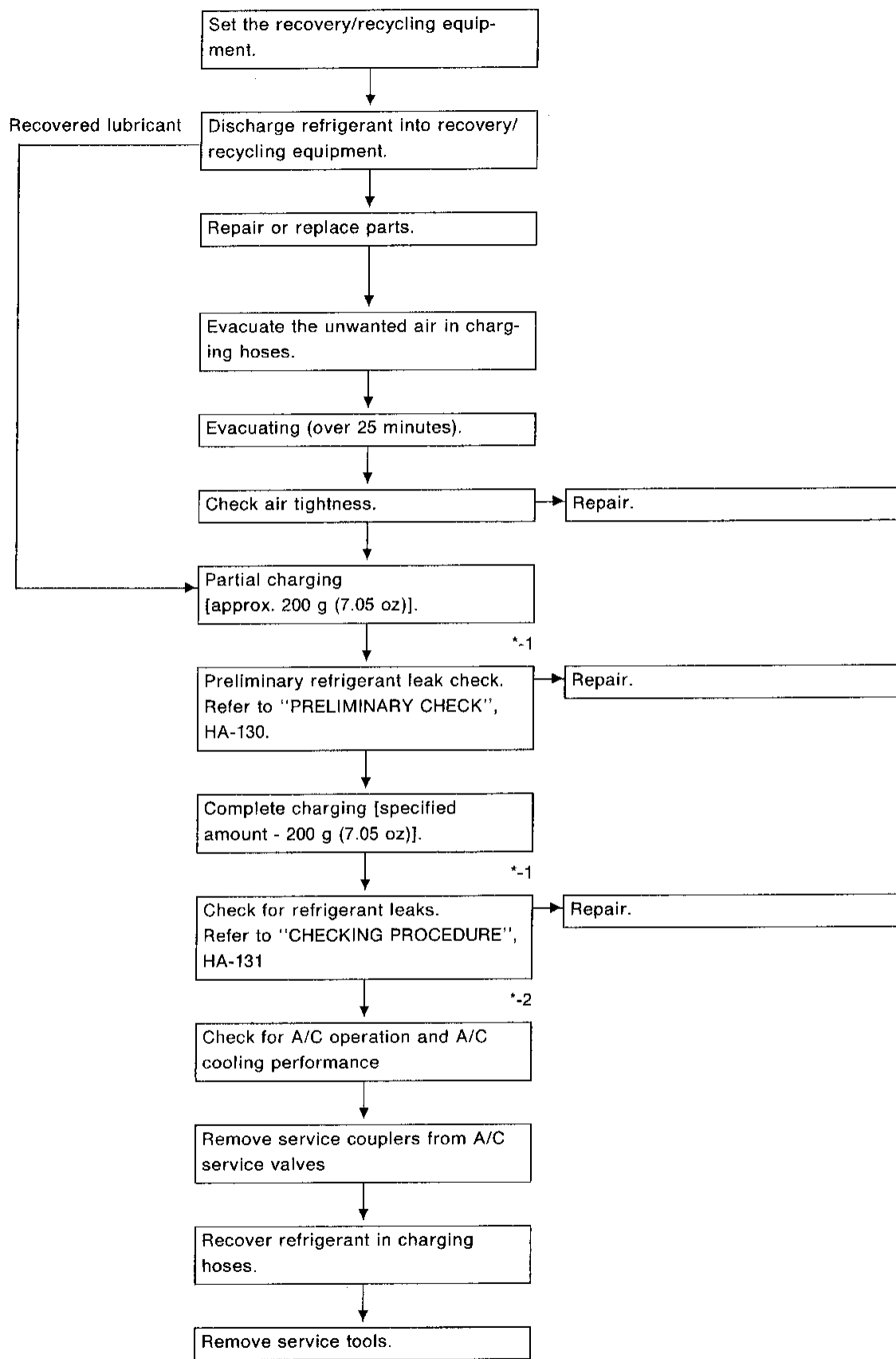

Note: \*-1 Before charging refrigerant, ensure engine is off.

\*-2 Before checking for leaks, start engine to activate air conditioning system then turn in off.  
Service valve caps must be attached to valves (to prevent leakage).

## Maintenance of Lubricant Quantity in Compressor

The lubricant in the compressor circulates through the system with the refrigerant. Add lubricant to compressor when replacing any component or a large amount of gas leakage has occurred. It is important to maintain the specified amount. If lubricant quantity is not maintained properly, the following malfunctions may result:

- Lack of lubricant: May lead to a seized compressor
- Excessive lubricant: Inadequate cooling (thermal exchange interference)

### CHECKING AND ADJUSTING

#### LUBRICANT

**Name: Nissan A/C System Oil Type S**  
**Part number: KLH00-PAGS0**

Adjust the lubricant quantity according to the flowchart shown below.

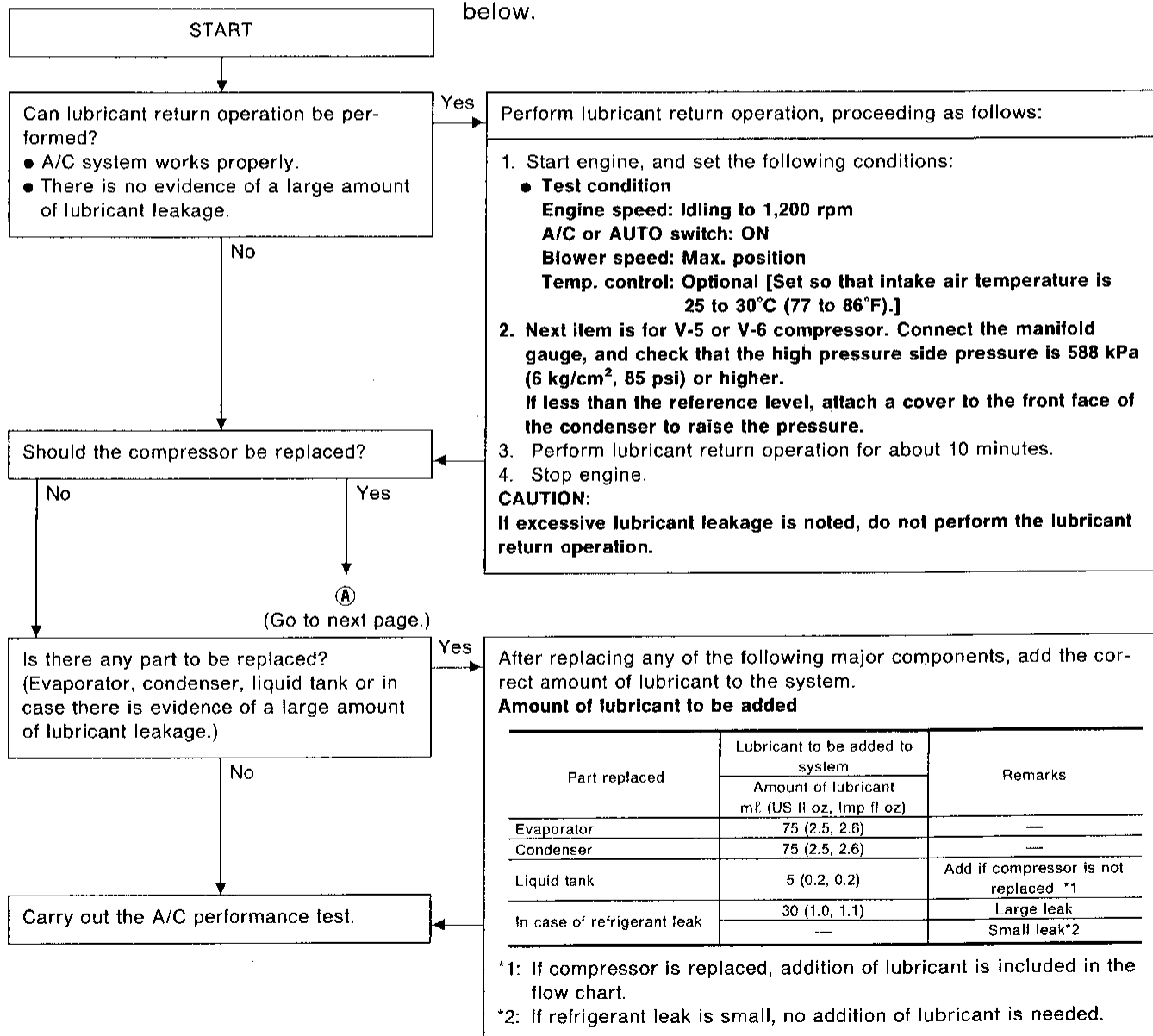

# SERVICE PROCEDURES

## Maintenance of Lubricant Quantity in Compressor (Cont'd)

Ⓐ

1. Discharge refrigerant into the refrigerant recovery/recycling equipment. Measure lubricant discharged into the recovery/ recycling equipment.
2. Remove the drain plug of the "old" (removed) compressor (applicable only to V-5, V-6 or DKS-16H compressor). Drain the lubricant into a graduated container and record the amount of drained lubricant.
3. Remove the drain plug and drain the lubricant from the "new" compressor into a separate, clean container.
4. Measure an amount of new lubricant equal to amount drained from "old" compressor. Add this lubricant to "new" compressor through the suction port opening.
5. Measure an amount of new lubricant equal to the amount recovered during discharging. Add this lubricant to "new" compressor through the suction port opening.
6. Torque the drain plug.

**V-5 or V-6 compressor: 18 - 19 N·m (1.8 - 1.9 kg·m, 13 - 14 ft-lb)**

**DKS-16H compressor: 14 - 16 N·m (1.4 - 1.6 kg·m, 10 - 12 ft-lb)**

7. If the liquid tank also needs to be replaced, add an additional 5 mℓ (0.2 US fl oz, 0.2 Imp fl oz) of lubricant at this time.

**Do not add this 5 mℓ (0.2 US fl oz, 0.2 Imp fl oz) of lubricant if only replacing the compressor.**

### Lubricant adjusting procedure for compressor replacement

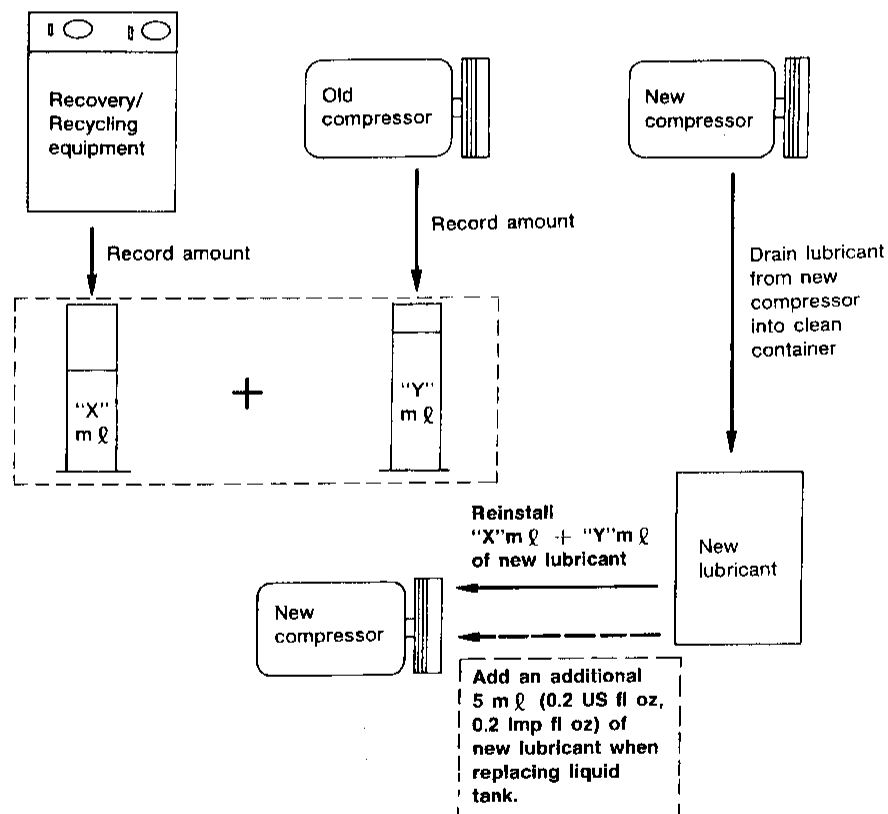

RHA065DD





## Checking Refrigerant Leaks

### PRELIMINARY CHECK

Perform a visual inspection of all refrigeration parts, fittings, hoses, and components for signs of A/C lubricant leakage, damage and corrosion.

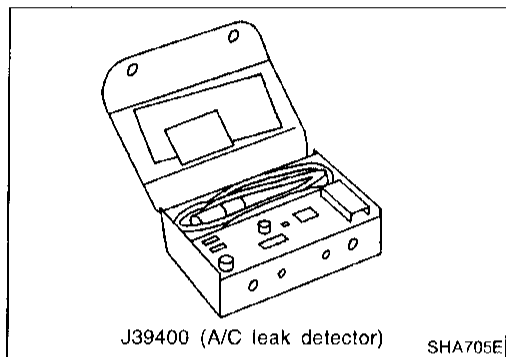

### PRECAUTIONS FOR HANDLING LEAK DETECTOR

When performing a refrigerant leak check, use a J39400 A/C leak detector or equivalent. Ensure that the instrument is calibrated and set properly per the operating instructions.

The leak detector is a delicate device. In order to use the leak detector properly, read the operating instructions and perform any specified maintenance.

**Other gases in the work area or substances on the A/C components, for example, anti-freeze, windshield washer fluid, solvents and cleaners, may falsely trigger the leak detector. Make sure the surfaces to be checked are clean. Do not allow the sensor tip of the detector to come into contact with any substance. This can also cause false readings and may damage the detector.**

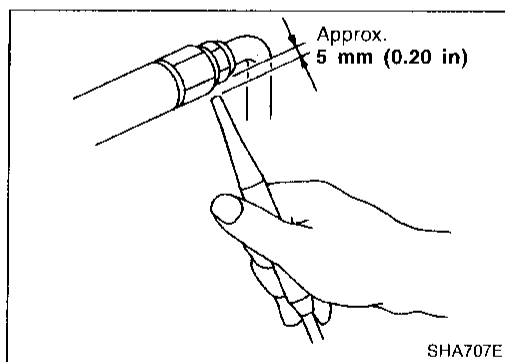

1. Position probe approximately 5 mm (0.20 in) away from point to be checked.

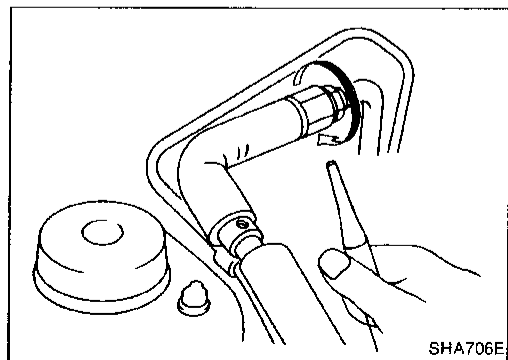

2. When testing, circle each fitting completely with probe.

## SERVICE PROCEDURES

### Checking Refrigerant Leaks (Cont'd)

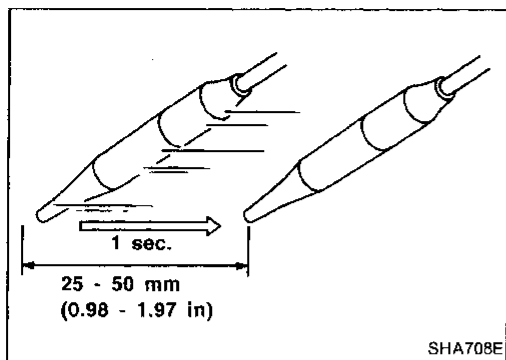

3. Move probe along component approximately 25 to 50 mm (0.98 to 1.97 in)/sec.

### CHECKING PROCEDURE

To prevent inaccurate or false readings, make sure there is no refrigerant vapor or tobacco smoke in the vicinity of the vehicle. Perform the leak test in calm area (low air/wind movement so that the leaking refrigerant is not dispersed).

1. Charge the system with the specified amount of refrigerant.
2. Run the engine with the A/C compressor ON for at least 2 minutes.
3. Stop engine.

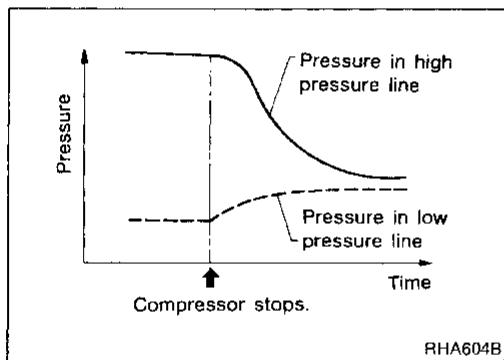

Refrigerant leaks should be checked immediately after stopping the engine. Begin with the leak detector on the high pressure line. The pressure in the high pressure line will gradually drop after refrigerant circulation stops and pressure in the low pressure line will gradually rise, as shown in the graph. Leaks are more easily detected when pressure is high.

4. Conduct the leak test from the high side to the low side at points ① through ①. Refer to HA-129.

Perform a leak check for the following areas carefully. Clean the component to be checked and move the leak detector probe completely around the connection/component.

- **Compressor**

Check the fitting of high and low pressure hoses, relief valve and shaft seal.

- **Liquid tank**

Check the pressure switch, tube fitting and the fusible plug mounts.

- **Service valves**

Check all around the service valves. Ensure service valve caps are secured on the service valves (to prevent leaks).

- **Cooling unit**

Turn blower fan on "High" for at least 15 seconds to dissipate any refrigerant trace in the cooling unit. Insert the leak detector probe into the drain hose immediately after stopping the engine. (Keep the probe inserted for at least ten seconds.)

## SERVICE PROCEDURES

### Checking Refrigerant Leaks (Cont'd)

5. If leak detector detects a leak, confirm the leak using soapy water.
6. Discharge A/C system and repair the leaking fitting or component as necessary.
7. Evacuate and recharge A/C system and perform the leak test to confirm no refrigerant leaks.

### Compressor Mounting

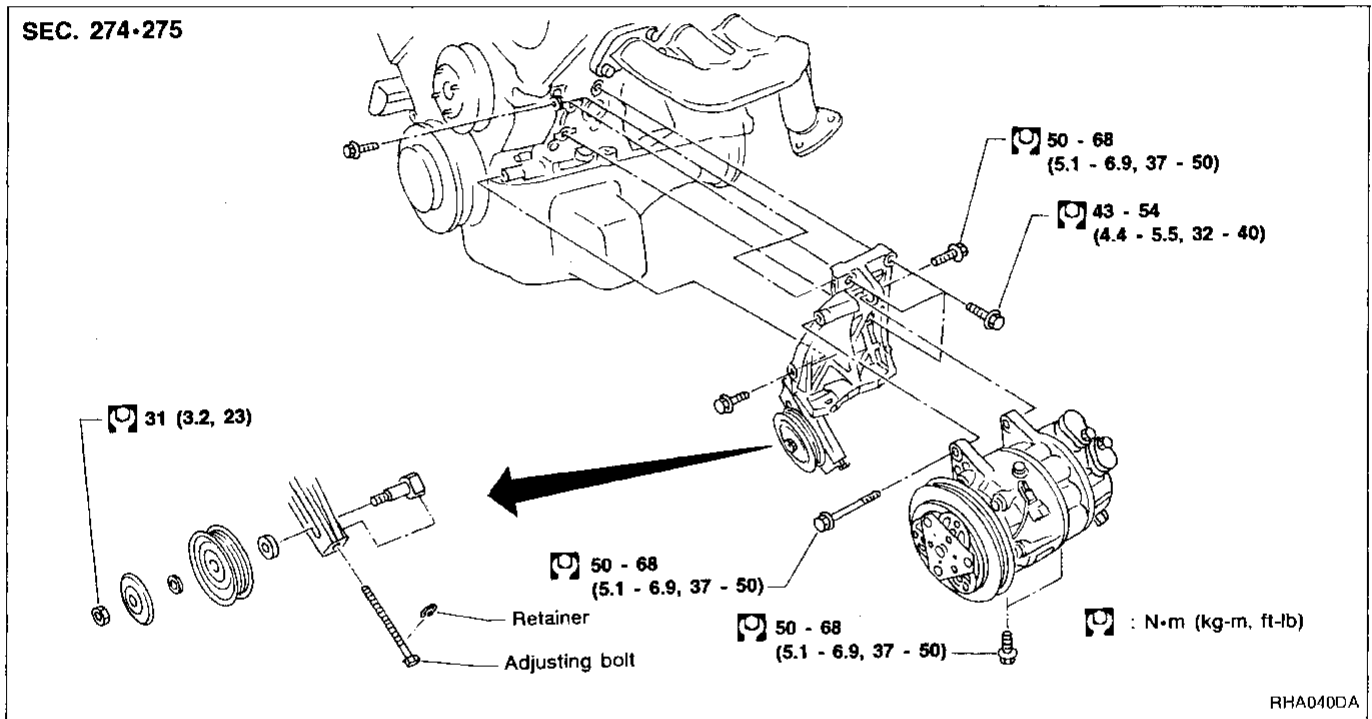

### Belt Tension

- Refer to Checking Drive Belts in MA section.

### Fast Idle Control Device (FICD)

- Refer to EC section.

Compressor

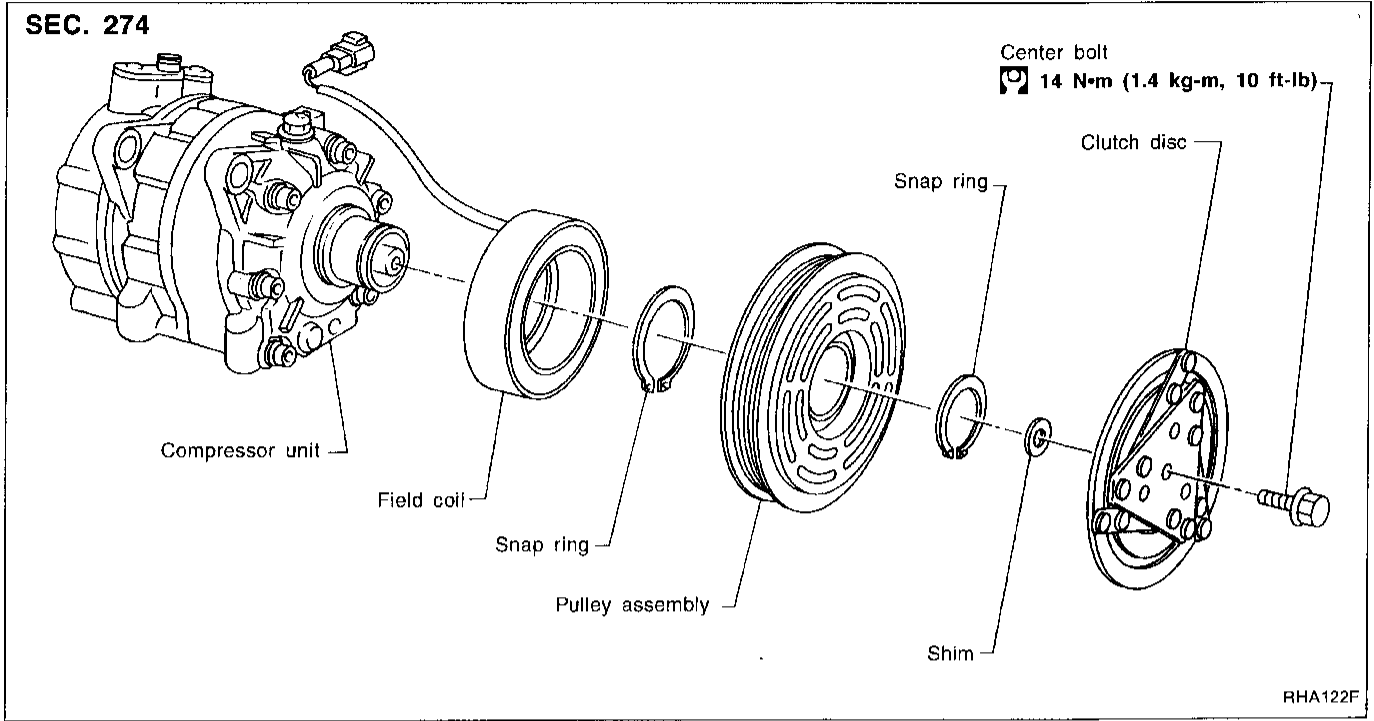

GI  
 MA  
 EM  
 LC  
 EC  
 FE  
 AT  
 PD

FA  
 RA

BR  
 ST

RS  
 BT

HA

EL  
 IDX

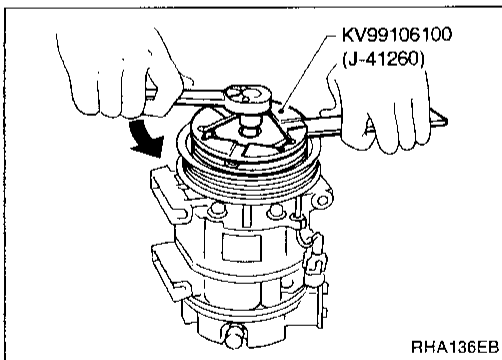

Compressor Clutch

REMOVAL

- When removing center bolt, hold clutch disc with clutch disc wrench.

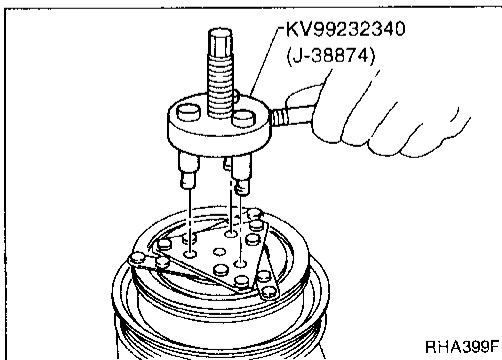

## SERVICE PROCEDURES

### Compressor Clutch (Cont'd)

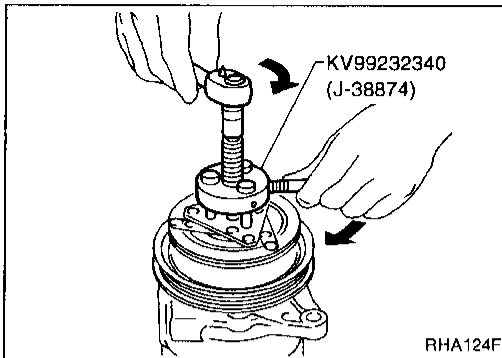

- Remove the clutch disc using the clutch disc puller. Insert the holder's three pins into the holes in the clutch disc. Rotate the holder clockwise to hook it onto the plate. Then, tighten the center bolt to remove the clutch disc. After removing the clutch disc, remove the shims from either the drive shaft or the clutch disc.

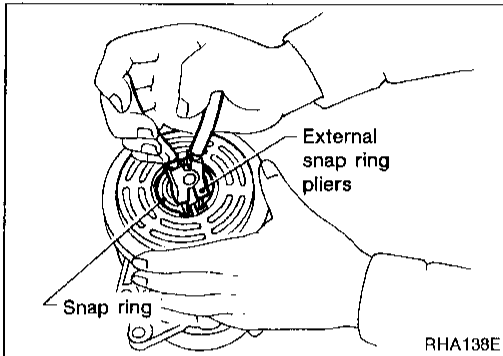

- Remove the snap ring using external snap ring pliers.

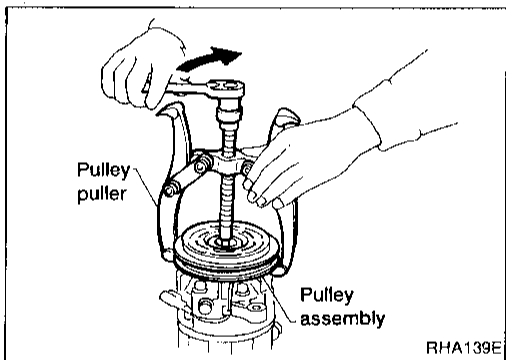

- Pulley removal  
Position the center pulley puller on the end of the drive shaft, and remove the pulley assembly using any commercially available pulley puller.  
**To prevent the pulley groove from being deformed, the puller claws should be positioned onto the edge of the pulley assembly.**

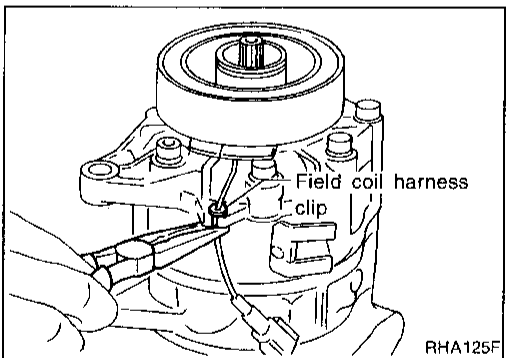

- Remove the field coil harness clip using a pair of pliers.

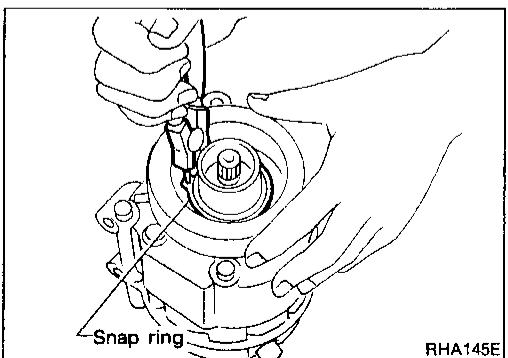

- Remove the snap ring using external snap ring pliers.

# SERVICE PROCEDURES

## Compressor Clutch (Cont'd)

### INSPECTION

#### Clutch disc

If the contact surface shows signs of damage due to excessive heat, replace clutch disc and pulley.

#### Pulley

Check the appearance of the pulley assembly. If the contact surface of pulley shows signs of excessive grooving, replace clutch disc and pulley. The contact surfaces of the pulley assembly should be cleaned with a suitable solvent before reinstallation.

#### Coil

Check coil for loose connection or cracked insulation.

### INSTALLATION

- Install the field coil.

**Be sure to align the coil's pin with the hole in the compressor's front head.**

- Install the field coil harness clip using a screwdriver.

- Install the pulley assembly using the installer and a hand press, and then install the snap ring using snap ring pliers.

- Install the clutch disc on the drive shaft, together with the original shim(s). Press the clutch disc down by hand.

- Using the holder to prevent clutch disc rotation, tighten the bolt to 14 N·m (1.4 kg-m, 10 ft-lb) torque.

**After tightening the bolt, check that the pulley rotates smoothly.**

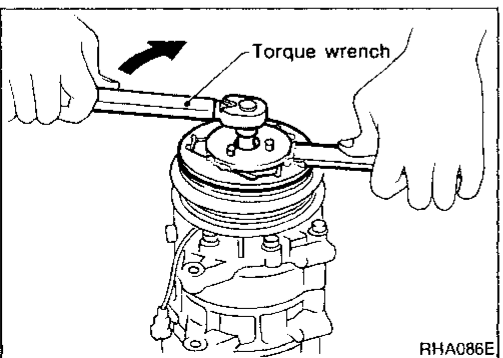
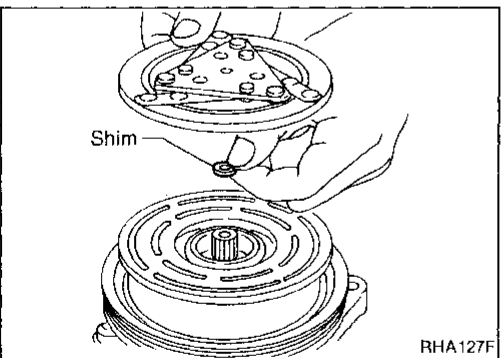
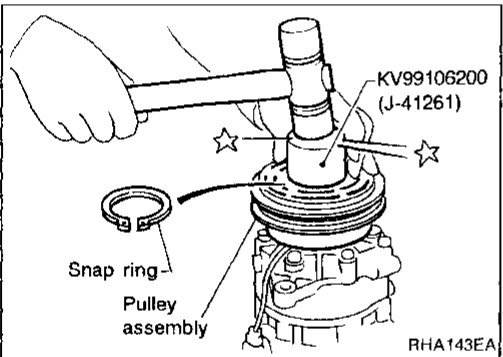
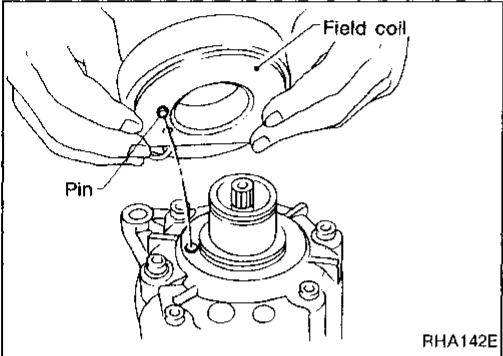
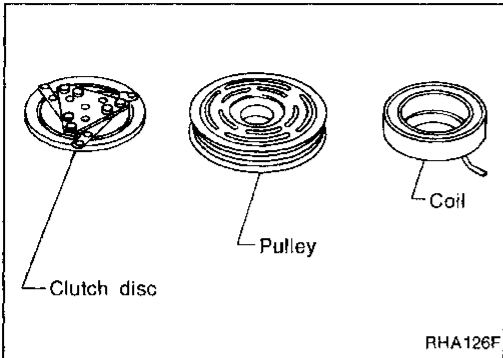

GI

MA

EM

LC

EC

FE

AT

PD

FA

RA

BR

ST

RS

BT

HA

EL

DX

## SERVICE PROCEDURES

### Compressor Clutch (Cont'd)

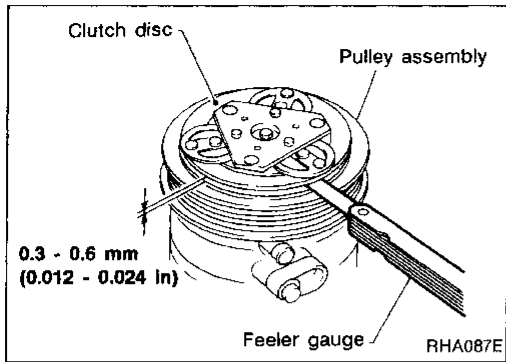

- Check clearance around the entire periphery of clutch disc.  
**Disc-to-pulley clearance:**  
**0.3 - 0.6 mm (0.012 - 0.024 in)**  
If the specified clearance is not obtained, replace adjusting spacer and readjust.

### BREAK-IN OPERATION

When replacing compressor clutch assembly, always carry out the break-in operation. This is done by engaging and disengaging the clutch about thirty times. Break-in operation raises the level of transmitted torque.



# SERVICE DATA AND SPECIFICATIONS (SDS)

## General Specifications

### COMPRESSOR

Model	CALSONIC make V-6
Type	V-6 variable displacement
Displacement    cm <sup>3</sup> (cu in)/rev.	
Max.	184 (11.228)
Min.	10.5 (0.641)
Cylinder bore x stroke mm (in)	37 (1.46) x [1.6 - 28.6 (0.063 - 1.126)]
Direction of rotation	Clockwise (viewed from drive end)
Drive belt	Poly V

### LUBRICANT

Model	CALSONIC make V-6
Name	Nissan A/C System Oil Type S
Part number	KLH00-PAGSO
Capacity mℓ (US fl oz, Imp fl oz)	
Total in system	250 (8.5, 8.8)
Compressor (Service part) charging amount	250 (8.5, 8.8)

### REFRIGERANT

Type	HFC-134a (R-134a)
Capacity                    kg (lb)	0.70 - 0.80 (1.54 - 1.76)

## Inspection and Adjustment

### ENGINE IDLING SPEED (When A/C is ON)

- Refer to EC section.

### BELT TENSION

- Refer to Checking Drive Belts (MA section).

GI

MA

EM

LC

EC

FE

AT

PD

FA

RA

BR

ST

RS

BT

HA

EL

IDX