

MAINTENANCE

SECTION MA

GI

MA

EM

LC

EC

FE

AT

PD

FA

RA

BR

ST

RS

BT

HA

EL

IOX

CONTENTS

PRECAUTIONS	2	CHASSIS AND BODY MAINTENANCE	16
Supplemental Restraint System (SRS) "AIR BAG" and "SEAT BELT PRE-TENSIONER".....	2	Checking A/T Fluid	16
GENERAL MAINTENANCE	3	Changing A/T Fluid.....	16
PERIODIC MAINTENANCE	5	Checking Differential Gear Oil	17
Schedule 1.....	6	Changing Differential Gear Oil.....	17
Schedule 2.....	7	Checking Brake Fluid Level and Leaks.....	17
RECOMMENDED FLUIDS AND LUBRICANTS	8	Checking Brake Lines and Cables.....	17
Fluids and Lubricants	8	Checking Disc Brake	18
SAE Viscosity Number.....	8	Balancing Wheels	18
Anti-freeze Coolant Mixture Ratio.....	9	Tire Rotation.....	18
ENGINE MAINTENANCE	10	Checking Steering Gear and Linkage.....	19
Checking Drive Belts	10	Checking Power Steering Fluid and Lines	19
Changing Engine Coolant.....	11	Checking Exhaust System	19
Checking Fuel Lines	12	Lubricating Locks, Hinges and Hood Latches.....	20
Changing Fuel Filter	12	Checking Seat Belts, Buckles, Retractors, Anchors and Adjusters	20
Changing Air Cleaner Filter	13	SERVICE DATA AND SPECIFICATIONS (SDS)	21
Changing Engine Oil.....	13	Engine Maintenance	21
Changing Oil Filter.....	14	Chassis and Body Maintenance.....	21
Changing Spark Plugs.....	15		
Checking EVAP Vapor Purge Lines.....	15		

PRECAUTIONS

Supplemental Restraint System (SRS) “AIR BAG” and “SEAT BELT PRE-TENSIONER”

The Supplemental Restraint System “Air Bag” and “Seat Belt Pre-tensioner”, used along with a seat belt, help to reduce the risk or severity of injury to the driver and front passenger in a frontal collision. The Supplemental Restraint System consists of air bag modules (located in the center of the steering wheel and on the instrument panel on the passenger side), seat belt pre-tensioners, a diagnosis sensor unit, warning lamp, wiring harness and spiral cable. Information necessary to service the system safely is included in the **RS section** of this Service Manual.

WARNING:

- To avoid rendering the SRS inoperative, which could increase the risk of personal injury or death in the event of a collision which would result in air bag inflation, all maintenance must be performed by an authorized INFINITI dealer.
- Improper maintenance, including incorrect removal and installation of the SRS, can lead to personal injury caused by unintentional activation of the system.
- Do not use electrical test equipment on any circuit related to the SRS unless instructed to in this Service Manual. SRS wiring harnesses are covered with yellow insulation either just before the harness connectors or for the complete harness, for easy identification.

GENERAL MAINTENANCE

General maintenance includes those items which should be checked during the normal day-to-day operation of the vehicle. They are essential if the vehicle is to continue operating properly. The owners can perform the checks and inspections themselves or they can have their INFINITI dealers do them.

Item	Reference page	GI
OUTSIDE THE VEHICLE		
The maintenance items listed here should be performed from time to time, unless otherwise specified.		
Tires Check the pressure with a gauge periodically when at a service station, including the spare, and adjust to the specified pressure if necessary. Check carefully for damage, cuts or excessive wear.	—	EM
Wheel nuts When checking the tires, make sure no nuts are missing, and check for any loose nuts. Tighten if necessary.	—	LC
Tire rotation Tires should be rotated every 12,000 km (7,500 miles).	MA-18	
Wheel alignment and balance If the vehicle pulls to either side while driving on a straight and level road, or if you detect uneven or abnormal tire wear, there may be a need for wheel alignment. If the steering wheel or seat vibrates at normal highway speeds, wheel balancing may be needed.	MA-20 FA-7	EC FE
Windshield wiper blades Check for cracks or wear if they do not wipe properly.	—	
Doors and engine hood Check that all doors and the engine hood operate smoothly as well as the trunk lid. Also make sure that all latches lock securely. Lubricate if necessary. Make sure that the secondary latch keeps the hood from opening when the primary latch is released. When driving in areas using road salt or other corrosive materials, check lubrication frequently.	MA-20	AT PD FA
INSIDE THE VEHICLE		
The maintenance items listed here should be checked on a regular basis, such as when performing periodic maintenance, cleaning the vehicle, etc.		
Lamps Make sure that the headlamps, stop lamps, tail lamps, turn signal lamps, and other lamps are all operating properly and installed securely. Also check headlamp aim.	—	RA BR
Warning lamps and buzzers/chimes Make sure that all warning lamps and buzzers/chimes are operating properly.	—	ST
Windshield wiper and washer Check that the wipers and washer operate properly and that the wipers do not streak.	—	RS
Windshield defroster Check that the air comes out of the defroster outlets properly and in good quantity when operating the heater or air conditioner.	—	BT
Steering wheel Check that it has the specified play. Be sure to check for changes in the steering condition, such as excessive play, hard steering or strange noises. Free play: Less than 35 mm (1.38 in)	—	HA EL
Seats Check seat position controls such as seat adjuster, seatback recliner, etc. to make sure they operate smoothly and that all latches lock securely in every position. Check that the head restraints move up and down smoothly and that the locks (if equipped) hold securely in all latched positions. Check that the latches lock securely for folding-down rear seatbacks.	—	DX
Seat belts Check that all parts of the seat belt system (e.g. buckles, anchors, adjusters and retractors) operate properly and smoothly and are installed securely. Check the belt webbing for cuts, fraying, wear or damage.	MA-20	
Brakes Check that the brake does not pull the vehicle to one side when applied.	—	
Brake pedal and booster Check the pedal for smooth operation and make sure it has the proper distance under it when depressed fully. Check the brake booster function. Be sure to keep the floor mats away from the pedal.	BR-9 BR-14	

GENERAL MAINTENANCE

Item	Reference page
Parking brake Check that the pedal has the proper travel and confirm that the vehicle is held securely on a fairly steep hill with only the parking brake applied.	BR-29
Automatic transmission "Park" mechanism Check that the brake pedal must be depressed for the selector lever to be moved from the "P" position. On a fairly steep hill check that the vehicle is held securely with the selector lever in the "P" position without applying any brakes.	—
UNDER THE HOOD AND VEHICLE	
The maintenance items listed here should be checked periodically (e.g. each time you check the engine oil or refuel).	
Windshield washer fluid Check that there is adequate fluid in the tank.	—
Engine coolant level Check the coolant level when the engine is cold.	MA-11
Radiator and hoses Check the front of the radiator and clean off any dirt, insects, leaves, etc., that may have accumulated. Make sure the hoses have no cracks, deformation, deterioration or loose connections.	—
Brake fluid level Make sure that the brake fluid level is between the "MAX" and "MIN" lines on the reservoir.	MA-17
Battery Check the fluid level in each cell. It should be between the "MAX" and "MIN" lines.	—
Engine drive belts Make sure that no belts is frayed, worn, cracked or oily.	MA-10
Engine oil level Check the level on the dipstick after parking the vehicle on a level spot and turning off the engine.	MA-13
Power steering fluid level and lines Check the level on the dipstick with the engine off. Check the lines for improper attachment, leaks, cracks etc.	MA-19
Automatic transmission fluid level Check the level on the dipstick after putting the selector lever in "P" with the engine idling.	MA-16
Exhaust system Make sure there are no loose supports, cracks or holes. If the sound of the exhaust seems unusual or there is a small of exhaust fumes, immediately locate the trouble and correct it.	MA-19
Underbody The underbody is frequently exposed to corrosive substances such as those used on icy roads or to control dust. It is very important to remove these substances, otherwise rust will form on the floor pan, frame, fuel lines and around the exhaust system. At the end of winter, the underbody should be thoroughly flushed with plain water, being careful to clean those areas where mud and dirt can easily accumulate.	—
Fluid leaks Check under the vehicle for fuel, oil water or other fluid leaks after the vehicle has been parked for a while. Water dripping from the air conditioner after use is normal. If you should notice any leaks or if gasoline fumes are evident, check for the cause and correct it immediately.	—

PERIODIC MAINTENANCE

Two different maintenance schedules are provided, and should be used, depending upon the conditions in which the vehicle is mainly operated. **After 60,000 miles (96,000 km) or 48 months, continue the periodic maintenance at the same mileage/time intervals.**

SCHEDULE 1

Follow Periodic Maintenance Schedule 1 if your driving habits frequently includes one or more of the following driving conditions:

- Repeated short trips of less than 5 miles (8 km).
- Repeated short trips of less than 10 miles (16 km) with outside temperatures remaining below freezing.
- Operating in hot weather in stop-and-go “rush hour” traffic.
- Extensive idling and/or low speed driving for long distances, such as police, taxi or door-to-door delivery use.
- Driving in dusty conditions.
- Driving on rough, muddy, or salt spread roads.
- Towing a trailer, using a camper or a car-top carrier.

SCHEDULE 2

Follow Periodic Maintenance Schedule 2 if none of the driving conditions shown in Schedule 1 apply to your driving habits.

GI

MA

EM

LC

EC

FE

AT

PD

FA

RA

BR

ST

RS

BT

HA

EL

IDX

PERIODIC MAINTENANCE

Schedule 1

Abbreviations: R = Replace I = Inspect. Correct or replace as necessary. [] = Perform service at the mileage intervals only

MAINTENANCE OPERATION

Perform at number of miles, kilometers or months, whichever comes first.	MAINTENANCE INTERVAL												Reference page			
	3.75	7.5	11.25	15	18.75	22.5	26.25	30	33.75	37.5	41.25	45		48.75	52.5	56.25
Miles x 1,000																
(km x 1,000)	(6)	(12)	(18)	(24)	(30)	(36)	(42)	(48)	(54)	(60)	(66)	(72)	(78)	(84)	(90)	(96)
Months	3	6	9	12	15	18	21	24	27	30	33	36	39	42	45	48

EMISSION CONTROL SYSTEM MAINTENANCE

Drive belts	See NOTE (1)															
Air cleaner filter	See NOTE (2)						[R]									
Vapor lines							I*									
Fuel lines							I*									
Fuel filter	See NOTE (3)*															
Engine coolant	See NOTE (4)															
Engine oil		R	R	R	R	R	R	R	R	R	R	R	R	R	R	R
Engine oil filter (Use Nissan Part No. 15208-60U00 or equivalent)		R	R	R	R	R	R	R	R	R	R	R	R	R	R	R
Spark plugs (PLATINUM-TIPPED type)																
Timing belt	See NOTE (5)															

CHASSIS AND BODY MAINTENANCE

Brake lines & cables																
Brake pads & discs		I	I	I	I	I	I	I	I	I	I	I	I	I	I	I
Automatic transmission oil & differential gear oil	See NOTE (6)															
Steering gear & linkage, axle & suspension parts		I	I	I	I	I	I	I	I	I	I	I	I	I	I	I
Steering linkage ball joints & front suspension ball joints		I	I	I	I	I	I	I	I	I	I	I	I	I	I	I
Exhaust system		I	I	I	I	I	I	I	I	I	I	I	I	I	I	I
Air bag system	See NOTE (7)															

- NOTE:**
- (1) After 60,000 miles (96,000 km) or 48 months, inspect every 15,000 miles (24,000 km) or 12 months.
 - (2) If operating mainly in dusty conditions, more frequent maintenance may be required.
 - (3) If vehicle is operated under extremely adverse weather conditions or in areas where ambient temperatures are either extremely low or extremely high, the filters might become clogged. In such an event, replace them immediately.
 - (4) After 60,000 miles (96,000 km) or 48 months, replace every 30,000 miles (48,000 km) or 24 months.
 - (5) Replace every 105,000 miles (168,000 km).
 - (6) If towing a trailer, using a camper or a car-top carrier, or driving on rough or muddy roads, change (not just inspect) oil at every 30,000 miles (48,000 km) or 24 months.
 - (7) Inspect the air bag system 10 years after the date of manufacture noted on the FMVSS certification label.
- * Maintenance items and intervals with "*" are recommended by INFINITI for reliable vehicle operation. The owner need not perform such maintenance in order to maintain the emission warranty or manufacturer recall liability. Other maintenance items and intervals are required.

Schedule 2

Abbreviations: R = Replace I = Inspect [] = Perform service at the mileage intervals only [] = Perform service at the mileage intervals only

MAINTENANCE OPERATION	MAINTENANCE INTERVAL										Reference page	
	Miles x 1,000 (km x 1,000) Months	7.5 (12) 6	15 (24) 12	22.5 (36) 18	30 (48) 24	37.5 (60) 30	45 (72) 36	52.5 (84) 42	60 (96) 48			
EMISSION CONTROL SYSTEM MAINTENANCE												
Drive belts	See NOTE (1)										I*	MA-10
Air cleaner filter					[R]						[R]	MA-13
Vapor lines											I*	MA-15
Fuel lines											I*	MA-12
Fuel filter	See NOTE (2)*											MA-12
Engine coolant	See NOTE (3)											MA-11
Engine oil		R	R	R	R	R	R	R	R	R	R	MA-13
Engine oil filter (Use Nissan Part No. 15208-60U00 or equivalent)		R	R	R	R	R	R	R	R	R	R	MA-14
Spark plugs (PLATINUM-TIPPED type)											[R]	MA-15
Timing belt	See NOTE (4)											EM-13
CHASSIS AND BODY MAINTENANCE												
Brake lines & cables											I	MA-17
Brake pads & discs											I	MA-18
Automatic transmission oil & differential gear oil											I	MA-16, 17
Steering gear linkage axle & suspension parts											I	MA-19, FA-5, RA-5
Exhaust system											I	MA-19
Air bag system	See NOTE (5)											RS-7

NOTE: (1) After 60,000 miles (96,000 km) or 48 months, inspect every 15,000 miles (24,000 km) or 12 months.
 (2) If vehicle is operated under extremely adverse weather conditions or in areas where ambient temperatures are either extremely low or extremely high, the filters might become clogged. In such an event, replace them immediately.
 (3) After 60,000 miles (96,000 km) or 48 months, replace every 30,000 miles (48,000 km) or 24 months.
 (4) Replace every 105,000 miles (168,000 km).
 (5) Inspect the air bag system 10 years after the date of manufacture noted on the FMVSS certification label. Maintenance items and intervals with "(*)" are recommended by INFINTI for reliable vehicle operation. The owner need not perform such maintenance in order to maintain the emission warranty or manufacturer recall liability. Other maintenance items and intervals are required.

RECOMMENDED FLUIDS AND LUBRICANTS

Fluids and Lubricants

	Capacity (Approximate)			Recommended fluids and lubricants
	US measure	Imp measure	Liter	
Engine oil (Refill)				
With oil filter	4-1/2 qt	3-3/4 qt	4.3	● API SG or SH and Energy Conserving II*2 ● API Certification Mark*2
Without oil filter	4-1/8 qt	3-3/8 qt	3.9	
Cooling system (With reservoir)	9-3/4 qt	8-1/8 qt	9.2	Anti-freeze coolant (Ethylene glycol base)
Differential gear oil	3-1/8 pt	2-5/8 pt	1.5	API GL-5*2
Automatic transmission fluid	8-3/4 qt	7-1/4 qt	8.3	Nissan Matic "D" (Continental U.S. and Alaska) or Genuine Nissan Automatic Transmission Fluid (Canada)*1
Power steering fluid	—	—	—	Type DEXRON™
Brake fluid	—	—	—	Genuine Brake Fluid*3 or equivalent DOT 3 (US FMVSS No. 116)
Multi-purpose grease	—	—	—	NLGI No. 2 (Lithium soap base)

*1: Dexron® III/Mercon® or equivalent may also be used. Outside the continental United States and Alaska contact an INFINITI dealership for more information regarding suitable fluids, including recommended brand(s) of Dexron® III/Mercon® or Dexron® IIE/Mercon® Automatic Transmission Fluid.

*2: For further details, see "SAE Viscosity Number".

*3: For more information regarding suitable fluids, contact an INFINITI dealership.

SAE Viscosity Number

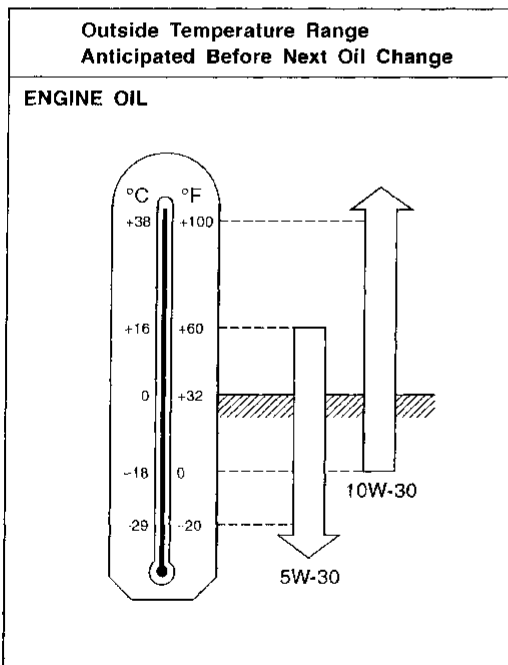

SAE 10W-30 viscosity oil is preferable for ambient temperatures above -18°C (0°F). SAE 5W-30 viscosity oil should be used only under extremely cold conditions.

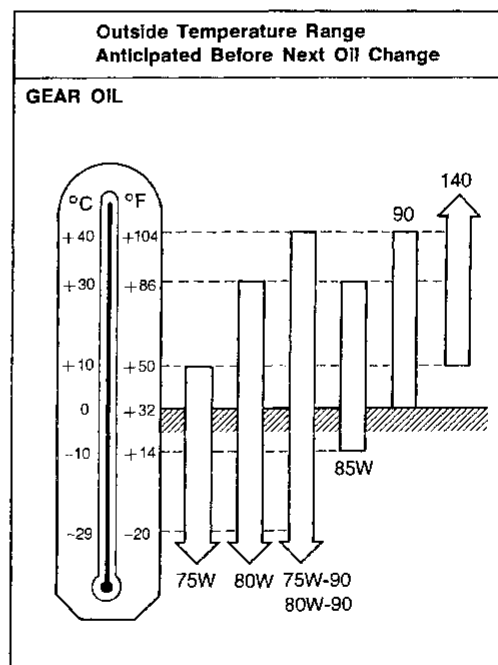

80W-90 for differential gear is preferable for ambient temperatures below 40°C (104°F).

Anti-freeze Coolant Mixture Ratio

The engine cooling system is filled at the factory with a high-quality, year-round, anti-freeze coolant solution. The anti-freeze solution contains rust and corrosion inhibitors. Therefore, additional cooling system additives are not necessary.

CAUTION:

When adding or replacing coolant, be sure to use only an ethylene glycol anti-freeze with the proper mixture ratio. See the following examples:

Outside temperature down to		Anti- freeze	Soft water
°C	°F		
-15	5	30%	70%
-35	-30	50%	50%

The use of other types of coolant solutions may damage your cooling system.

GI

MA

EM

LC

EC

FE

AT

PD

FA

RA

BR

ST

RS

BT

HA

EL

IOX

Checking Drive Belts

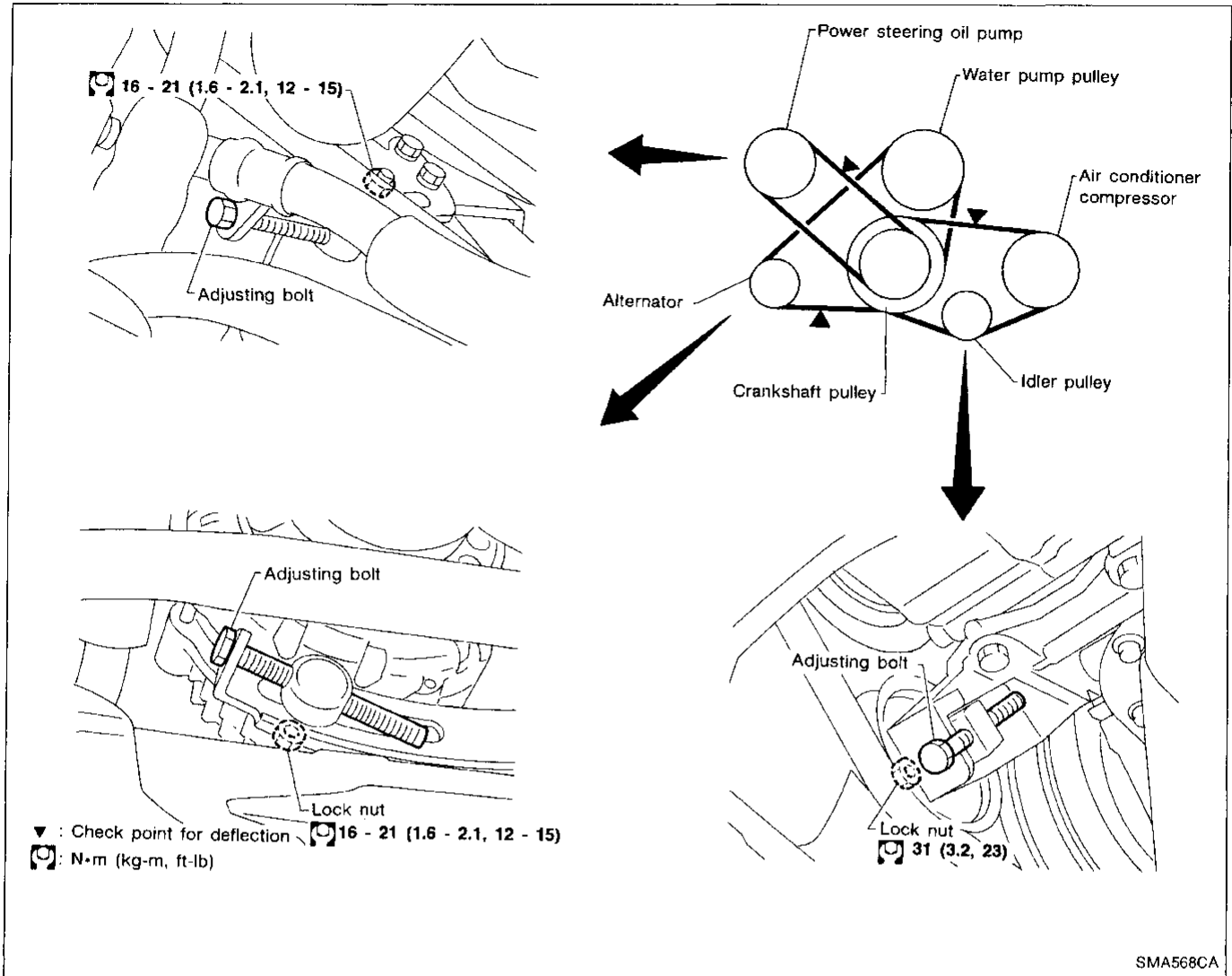

1. Inspect for cracks, fraying, wear or oil. If necessary, replace with a new one.
2. Inspect drive belt deflection by pushing midway between pulleys.

Inspect drive belt deflection when engine is cold.

Belt deflection:

Unit: mm (in)

	Used belt deflection		Deflection of new belt
	Limit	Deflection after adjustment	
Alternator	10 (0.39)	6.5 - 7.5 (0.256 - 0.295)	5.5 - 6.5 (0.217 - 0.256)
Air conditioner compressor	14 (0.55)	8.5 - 9.5 (0.335 - 0.374)	7.5 - 8.5 (0.295 - 0.335)
Power steering oil pump	20 (0.79)	13 - 15 (0.51 - 0.59)	11 - 13 (0.43 - 0.51)
Applied pushing force	98 N (10 kg, 22 lb)		

Adjust if belt deflection exceed the limit.

Changing Engine Coolant

WARNING:

To avoid the danger of being scalded, never change the coolant when the engine is hot.

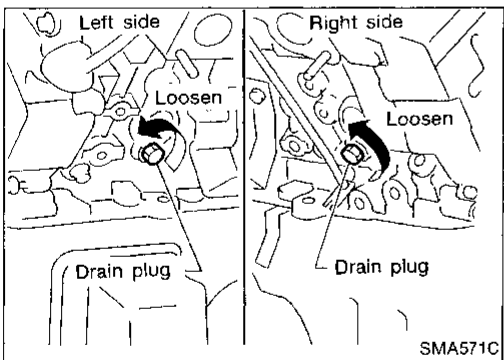
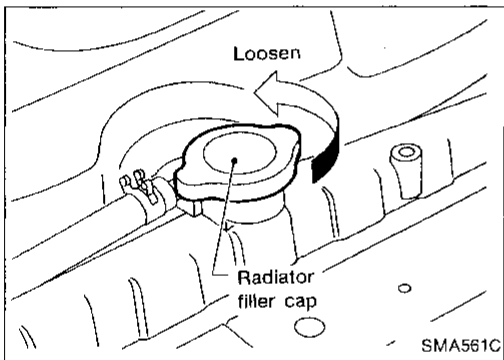
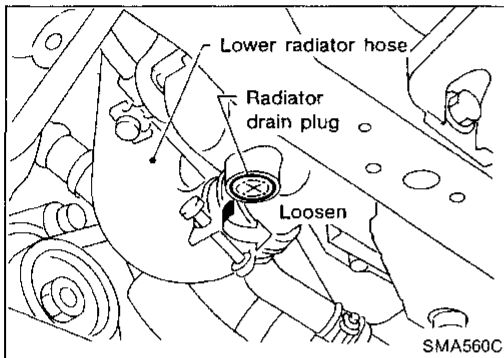

1. Open drain plug at the bottom of radiator, and remove radiator filler cap.

2. Open drain plugs on both sides of cylinder block.
 - **Left side drain plug is located beside the left side engine mounting.**

3. Flush cooling system by running fresh water through radiator.
4. Close drain plug and tighten drain plugs securely.
 - **Apply sealant to the drain plug thread.**
 \square : 34 - 44 N·m (3.5 - 4.5 kg-m, 25 - 33 ft-lb)

GI

MA

EM

LC

EC

FE

AT

PD

FA

RA

BR

ST

RS

BT

HA

EL

IDX

ENGINE MAINTENANCE

Changing Engine Coolant (Cont'd)

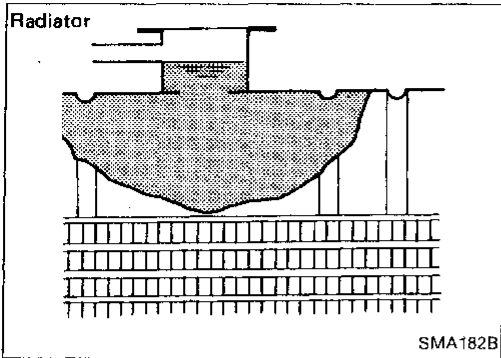

5. Fill radiator slowly with proper mixture of coolant and water. Fill reservoir tank up to the "H" level. Then install radiator cap and close air release plug.

Coolant capacity (With reservoir tank):

9.2ℓ (9-3/4 US qt, 8-1/8 Imp qt)

Reservoir tank capacity:

1.0ℓ (1-1/8 US qt, 7/8 Imp qt)

Regarding anti-freeze coolant mixture ratio, see MA-9.

Pour coolant through coolant filler neck slowly to allow air in system to escape.

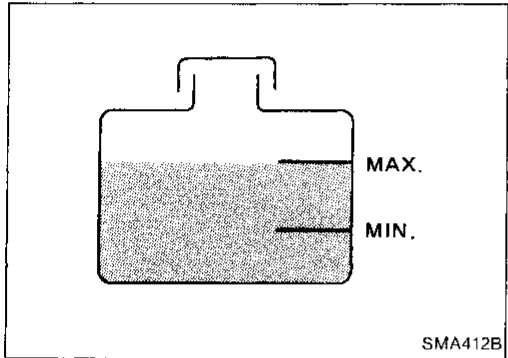

6. Start engine and warm it up until it reaches normal operating temperature. Then race engine 2 or 3 times under no-load. Watch coolant temperature gauge for signs of overheating.
 7. Stop engine. After it completely cools down, refill radiator up to filler opening. Fill reservoir tank up to the "H" level.
 8. Check drain cock and drain plug for any sign of leakage.
- Clean excess coolant from engine block.

Checking Fuel Lines

Inspect fuel lines and tank for improper attachment and for leaks, cracks, damage, chafing or deterioration. If necessary, repair or replace.

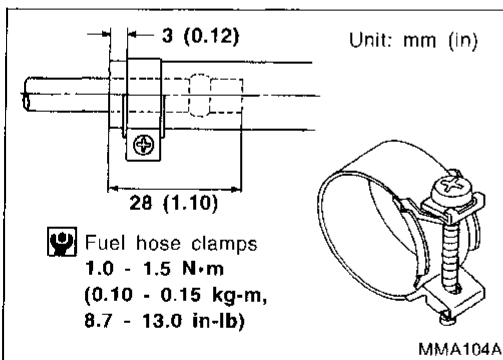
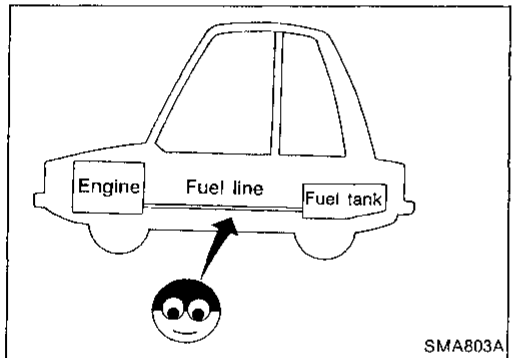

CAUTION:

Tighten high-pressure rubber hose clamp so that clamp end is 3 mm (0.12 in) from hose end.

Tightening torque specifications are the same for all rubber hose clamps.

Ensure that screw does not contact adjacent parts.

Changing Fuel Filter

WARNING:

Before removing fuel filter, release fuel pressure from fuel line to eliminate danger.



1. Perform "FUEL PRESSURE RELEASE" in "WORK SUPPORT" mode and release fuel pressure to zero.
2. Turn ignition switch off.

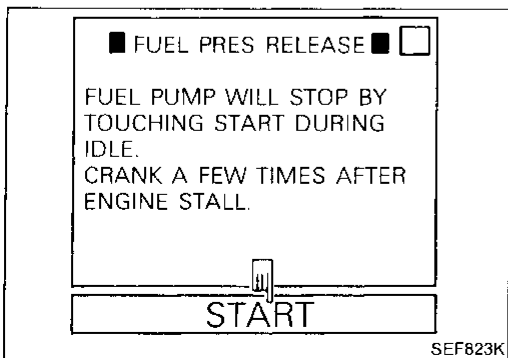

ENGINE MAINTENANCE

Changing Fuel Filter (Cont'd)

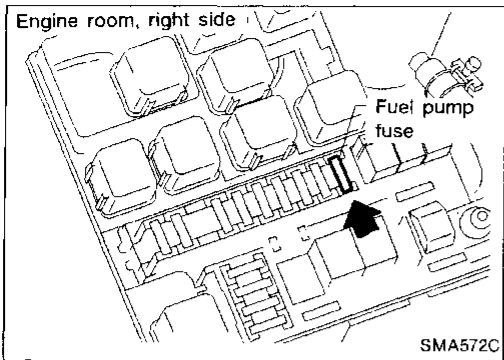

1. Remove fuel pump fuse.
2. Start engine.
3. After engine stalls, crank engine two or three times to make sure that fuel pressure is released.
4. Turn ignition switch off and reconnect fuel pump relay.

CI

MA

EM

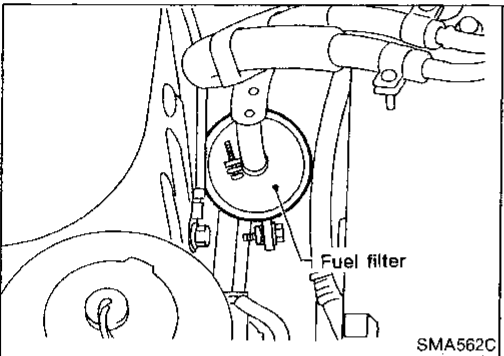

3. Loosen fuel hose clamps.
 4. Replace fuel filter.
- Be careful not to spill fuel over engine compartment. Place a shop towel to absorb fuel.
 - Use a high-pressure type fuel filter. Do not use a synthetic resinous fuel filter.
 - When tightening fuel hose clamps, refer to "Checking Fuel Lines" (MA-12).

LC

EC

FE

AT

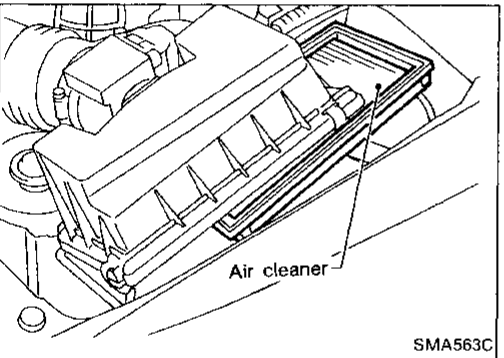

Changing Air Cleaner Filter

Unfasten clamps to change air cleaner filter.

The viscous paper type filter does not need cleaning between renewals.

PD

FA

RA

BR

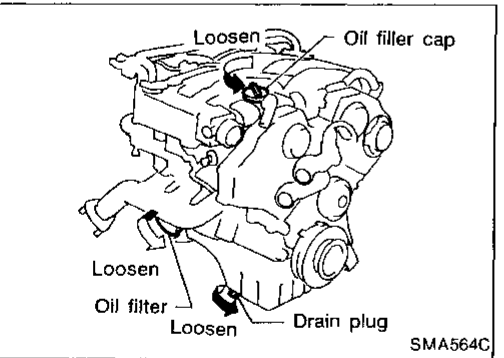

Changing Engine Oil

WARNING:

- Be careful not to burn yourself, as the engine oil is hot.
- Prolonged and repeated contact with used engine oil may cause skin cancer; try to avoid direct skin contact with used oil. If skin contact is made, wash thoroughly with soap or hand cleaner as soon as possible.

ST

RS

BT

HA

1. Warm up engine, and check for oil leakage from engine components.
2. Remove drain plug and oil filler cap.

EL

3. Drain oil and refill with new engine oil.

Oil specification and viscosity:

- API SG or SH and Energy Conserving II
- API Certification Mark
- See "RECOMMENDED FLUIDS AND LUBRICANTS" (MA-8).

IDX

Refill oil capacity (Approximately): ℓ (US qt, Imp qt)

With oil filter

4.3 (4-1/2, 3-3/4)

Without oil filter

3.9 (4-1/8, 3-3/8)

ENGINE MAINTENANCE

Changing Engine Oil (Cont'd)

CAUTION:

- Be sure to clean drain plug and install with new washer.
Oil pan drain plug:
⚙️: 29 - 39 N·m (3.0 - 4.0 kg-m, 22 - 29 ft-lb)
- The refill capacity depends on the oil temperature and drain time; use the "Refill oil capacity" values as a reference and be certain to check with the dipstick when changing the oil.

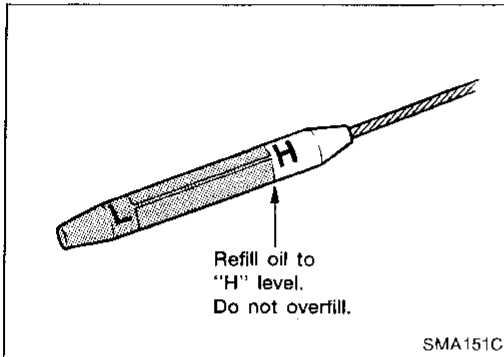

4. Check oil level.
5. Start engine and check area around drain plug and oil filter for oil leakage.
6. Run engine for a few minutes, then turn it off. After several minutes, check oil level.

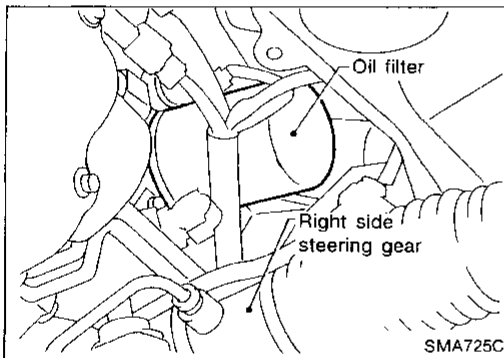

Changing Oil Filter

1. Remove oil filter with a suitable tool.

WARNING:

Be careful not to burn yourself, as the engine and engine oil are hot.

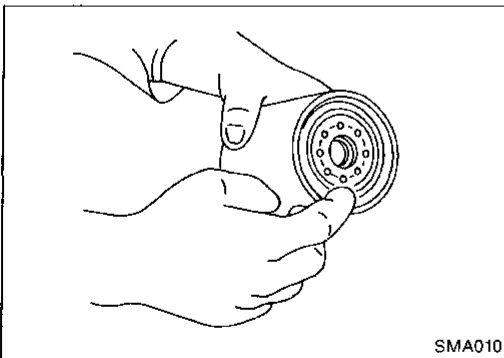

2. Clean oil filter mounting surface on cylinder block. Coat rubber seal of new oil filter with engine oil.

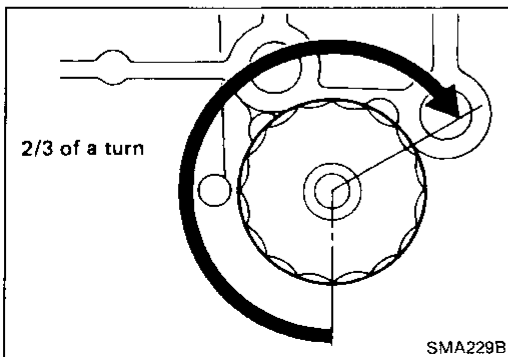

3. Screw in the oil filter until a slight resistance is felt, then tighten additionally more than 2/3 turn.
4. Add engine oil.

Refer to Changing Engine Oil (MA-13).

- Clean excess oil from engine block.

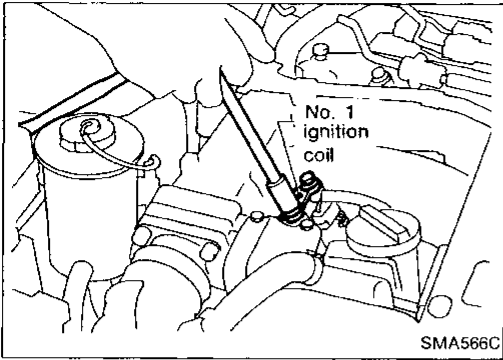

Changing Spark Plugs

1. Disconnect ignition coil harness connector.
2. Loosen ignition coil fixing bolts and pull out coil from intake manifold collector.

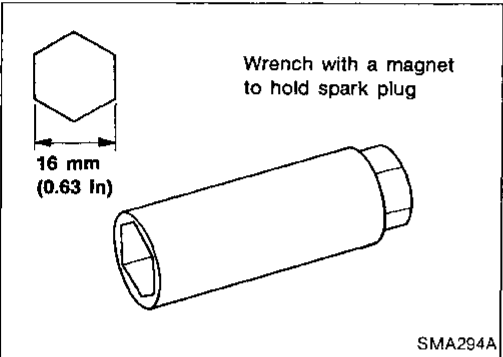

3. Remove spark plugs with suitable spark plug wrench.

Spark plug (Platinum-tipped type):

Make	NGK
Standard type	PFR5B-11
Cold type	PFR6B-11 PFR7B-11

: 20 - 29 N·m (2.0 - 3.0 kg-m, 14 - 22 ft-lb)

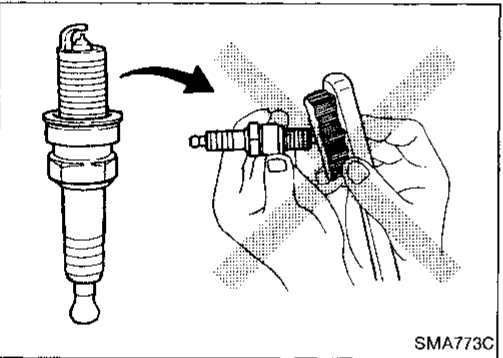

- Do not use a wire brush for cleaning.
- If plug tip is covered with carbon, spark plug cleaner may be used.

Cleaner air pressure:

Less than 588 kPa (6 kg/cm², 85 psi)

Cleaning time:

Less than 20 seconds

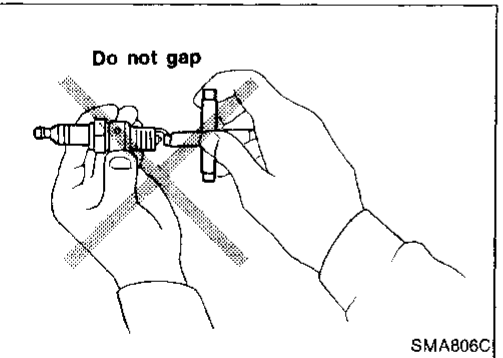

- Checking and adjusting plug gap is not required between change intervals.

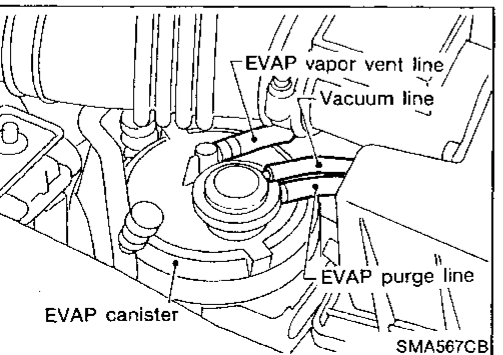

Checking EVAP Vapor Purge Lines

1. Visually inspect EVAP vapor purge lines for improper attachment and for cracks, damage, loose connections, chafing and deterioration.
2. Inspect fuel tank filler cap vacuum relief valve for clogging, sticking, etc.

Refer to "EVAPORATIVE EMISSION SYSTEM" in EC section.

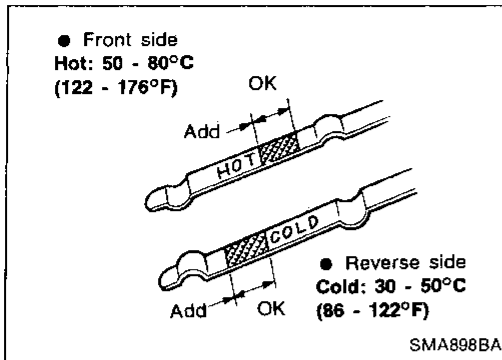

Checking A/T Fluid

1. Warm up engine.
2. Check for fluid leakage.
3. Before driving, fluid level can be checked at fluid temperatures of 30 to 50°C (86 to 122°F) using "COLD" range on dipstick.
 - a. Park vehicle on level surface and set parking brake.
 - b. Start engine and move selector lever through each gear position. Leave selector lever in "P" position.
 - c. Check fluid level with engine idling.
 - d. Remove dipstick and note reading. If level is at low side of either range, and fluid to the charging pipe.
 - e. Re-insert dipstick into charging pipe as far as it will go.
 - f. Remove dipstick and note reading. If reading is at low side of range, add fluid to the charging pipe.

Do not overfill.

4. Drive vehicle for approximately 5 minutes in urban areas.
5. Re-check fluid level at fluid temperatures of 50° to 80°C (122° to 176°F) using "HOT" range on dipstick.

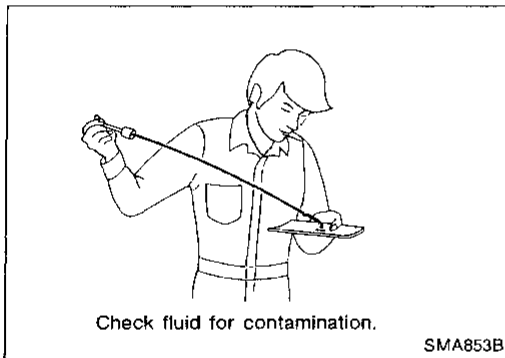

6. Check fluid condition.
 - If fluid is very dark or smells burned, refer to AT section for checking operation of A/T. Flush cooling system after repair of A/T.
 - If A/T fluid contains frictional material (clutches, bands, etc.), replace radiator and flush cooler line using cleaning solvent and compressed air after repair of A/T. Refer to LC section ("Radiator", "ENGINE COOLING SYSTEM").

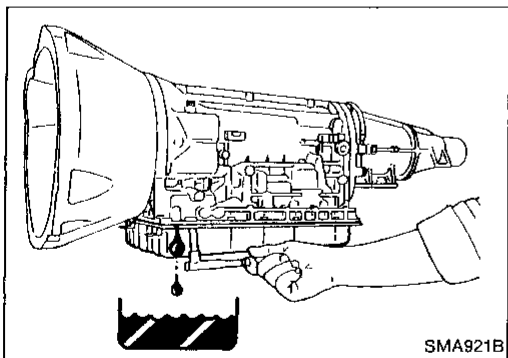

Changing A/T Fluid

1. Warm up A/T fluid.
2. Stop engine.
3. Drain A/T fluid from drain plug and refill with new A/T fluid. Always refill same volume with drained fluid.

Fluid grade:

- Nissan Matic "D" (Continental U.S. and Alaska) or Genuine Nissan Automatic Transmission Fluid (Canada)
- Refer to "RECOMMENDED FLUIDS AND LUBRICANTS", MA-8.

Fluid capacity (With torque converter):

8.3 ℓ (8-3/4 US qt, 7-1/4 Imp qt)

Drain plug:

: 29 - 39 N·m (3.0 - 4.0 kg·m, 22 - 29 ft·lb)

4. Run engine at idle speed for five minutes.
5. Check fluid level and condition. Refer to "Checking A/T Fluid". If fluid is still dirty, repeat step 2. through 5.

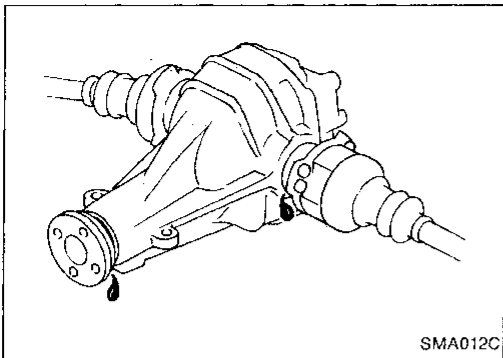

Checking Differential Gear Oil

- Check for oil leakage and oil level.

Filler plug:

: 39 - 59 N·m (4 - 6 kg-m, 29 - 43 ft-lb)

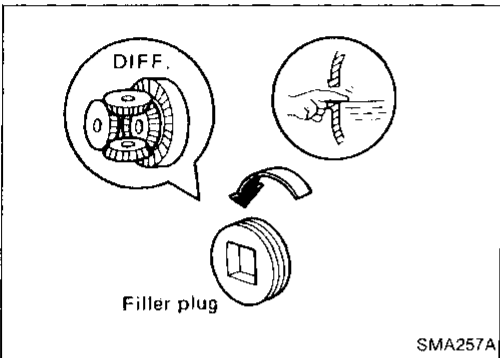

Changing Differential Gear Oil

1. Drain oil from drain plug and refill with new gear oil.
2. Check oil level.

Oil grade:

API GL-5

Viscosity:

See "RECOMMENDED FLUIDS AND LUBRICANTS", MA-8.

Oil capacity:

1.5 l (3-1/8 US pt, 2-5/8 Imp pt)

Drain plug:

: 39 - 59 N·m (4 - 6 kg-m, 29 - 43 ft-lb)

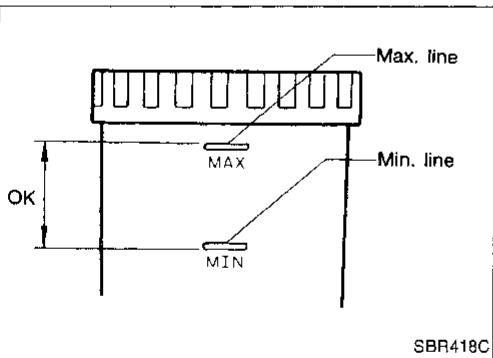

Checking Brake Fluid Level and Leaks

- If fluid level is extremely low, check brake system for leaks.

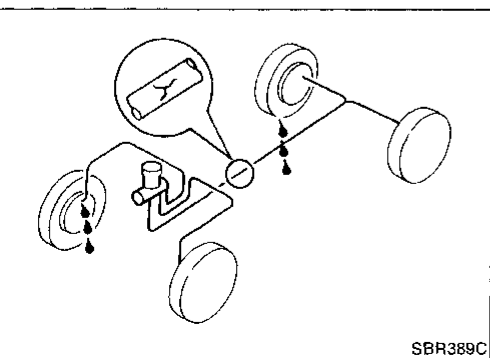

Checking Brake Lines and Cables

- Check brake fluid lines and parking brake cable for improper attachment, leaks, chafing, abrasions, or deterioration.

GI

MA

EM

LC

EC

FE

AT

PD

FA

RA

BR

ST

RS

BT

HA

EL

IDX

CHASSIS AND BODY MAINTENANCE

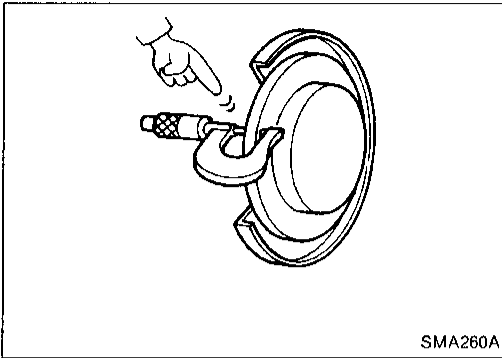

SMA260A

Checking Disc Brake

ROTOR

- Check condition and thickness.

Unit: mm (in)

	Front	Rear
Standard thickness	28 (1.10)	16 (0.63)
Minimum thickness	26.0 (1.024)	14.0 (0.551)

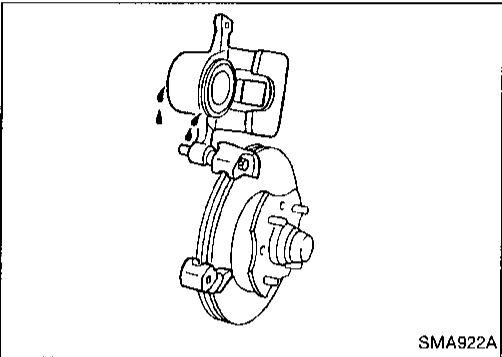

SMA922A

CALIPER

- Check operation and for leakage.

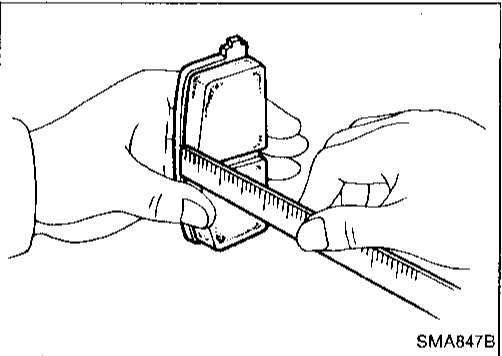

SMA847B

PAD

- Check for wear or damage

Unit: mm (in)

	Front	Rear
Standard thickness	9.5 (0.374)	10 (0.39)
Minimum thickness	2.0 (0.079)	

Balancing Wheels

- Adjust wheel balance using road wheel center.
Wheel balance (Maximum allowable unbalance):
Refer to SDS, MA-21.

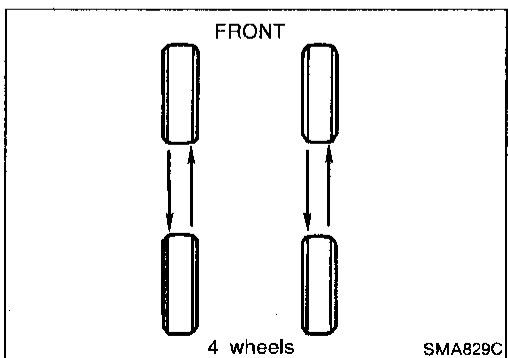

SMA829C

Tire Rotation

- Do not include the T-type spare tire when rotating the tires.
Wheel nuts:
: 98 - 118 N·m (10 - 12 kg·m, 72 - 87 ft·lb)

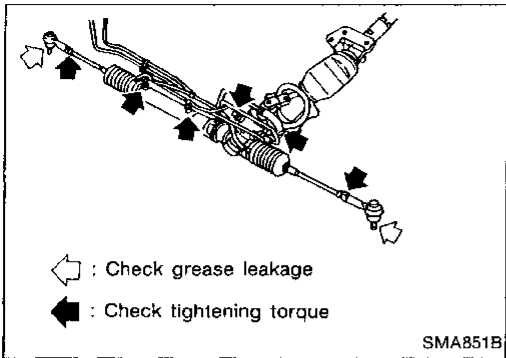

Checking Steering Gear and Linkage

STEERING GEAR

- Check gear housing and boots for looseness, damage or grease leakage.
- Check connection with steering column for looseness.

STEERING LINKAGE

- Check ball joint, dust cover and other component parts for looseness, wear, damage or grease leakage.

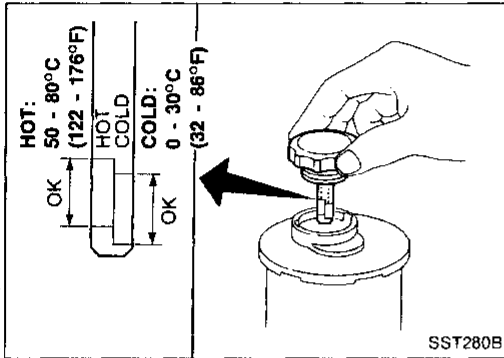

Checking Power Steering Fluid and Lines

CHECKING FLUID LEVEL

- Check fluid level with engine off.
- Check fluid level with dipstick on reservoir cap. Use "HOT" range at fluid temperatures of 50 to 80°C (122 to 176°F). Use "COLD" range at fluid temperatures of 0 to 30°C (32 to 86°F).

CAUTION:

- Do not overfill.
- Recommended fluid is Automatic Transmission Fluid type "DEXRON™II" or equivalent.

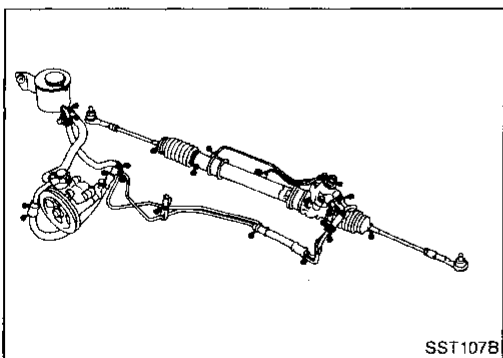

CHECKING LINES

- Check lines for improper attachment, leaks, cracks, damage, loose connections, chafing or deterioration.
- Check rack boots for accumulation of power steering fluid.

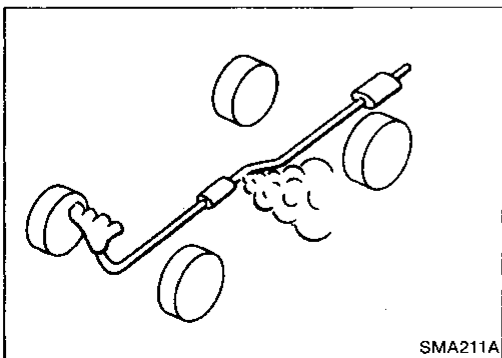

Checking Exhaust System

- Check exhaust pipes, muffler and mounting for improper attachment, leaks, cracks, damage, loose connections, chafing and deterioration.

GI

MA

EM

LC

EC

FE

AT

PD

FA

RA

BR

ST

RS

BT

HA

EL

IDX

Lubricating Locks, Hinges and Hood Latches

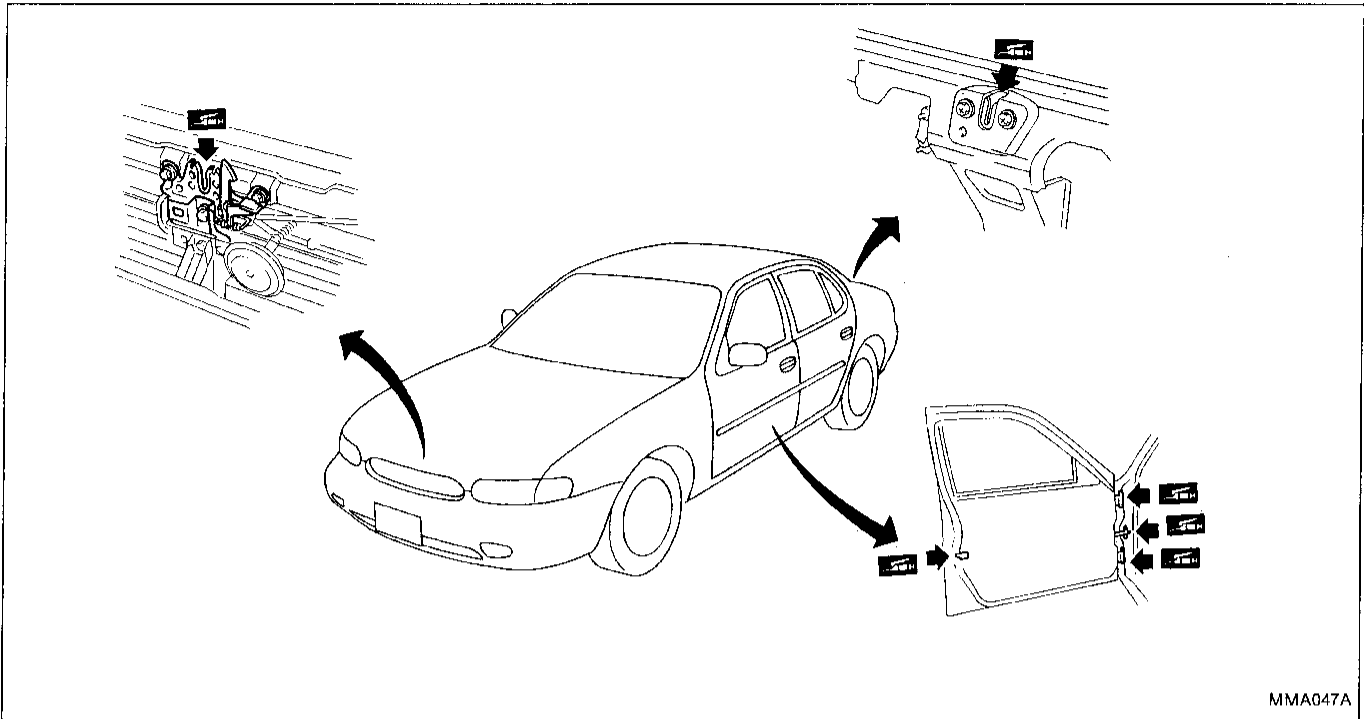

MMA047A

Checking Seat Belts, Buckles, Retractors, Anchors and Adjusters

CAUTION:

- After any collision, inspect all seat belt assemblies, including retractors and other attached hardware (i.e. guide rail set). Nissan recommends to replace all seat belt assemblies in use during a collision, unless not damaged and properly operating after minor collision. Also inspect seat belt assemblies not in use during a collision, and replace if damaged or improperly operating.
- If any component of seat belt assembly is questionable, do not repair. Replace as seat belt assembly.
- If webbing is cut, frayed, or damaged, replace belt assembly.
- Never oil tongue and buckle.
- Use a genuine seat belt assembly.

For seat belt pre-tensioner, refer to RS section.

Anchor bolt

 43 - 55 (4.4 - 5.6, 32 - 41)

 : N·m (kg-m, ft-lb)

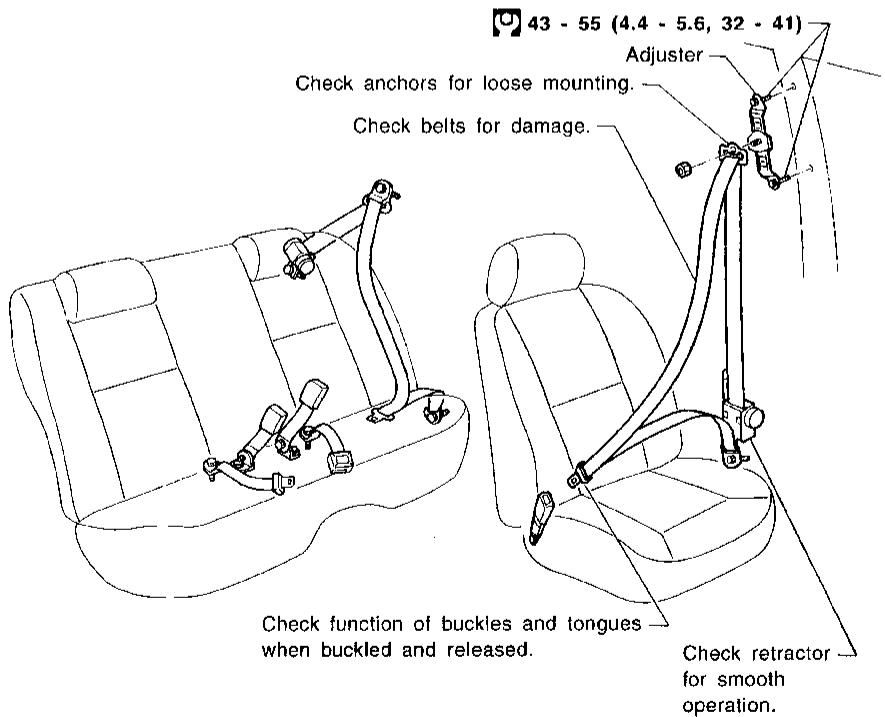

MMA109A

SERVICE DATA AND SPECIFICATIONS (SDS)

Engine Maintenance

INSPECTION AND ADJUSTMENT

Drive belt deflection

Unit: mm (in)

	Used belt deflection		Deflection of new belt
	Limit	Deflection after adjustment	
Alternator	10 (0.39)	6.5 - 7.5 (0.256 - 0.295)	5.5 - 6.5 (0.217 - 0.256)
Air conditioner compressor	14 (0.55)	8.5 - 9.5 (0.335 - 0.374)	7.5 - 8.5 (0.295 - 0.335)
Power steering oil pump	20 (0.79)	13 - 15 (0.51 - 0.59)	11 - 13 (0.43 - 0.51)
Applied pushing force	98 N (10 kg, 22 lb)		

Oil capacity (Refill)

Unit: ℓ (US qt, Imp qt)

With oil filter	4.3 (4-1/2, 3-3/4)	GI
Without oil filter	3.9 (4-1/8, 3-3/8)	

Coolant capacity

Unit: ℓ (US qt, Imp qt)

With reservoir tank	9.2 (9-3/4, 8-1/8)	EM
Reservoir tank	1.0 (1-1/8, 7/8)	LC

Spark plug

Make	NGK	FE
Standard type	PFR5B-11	
Cold type	PFR6B-11	AT
	PFR7B-11	

Chassis and Body Maintenance

INSPECTION AND ADJUSTMENT

Wheel balance

Maximum allowable unbalance	Dynamic (at rim flange)	10 (0.35) (One side)
	Static	20 (0.71)

GI

MA

EM

LC

EC

FE

AT

PD

FA

RA

BR

ST

RS

BT

HA

EL

DX