

# RESTRAINT SYSTEM

# SECTION RS

GI  
MA  
EM  
LC  
EC  
FE  
AT  
PD  
FA  
RA  
BR  
ST  
RS  
BT  
HA  
EL  
IDX

## CONTENTS

<b>PRECAUTION</b> .....	2	Installation — Air Bag Module and Spiral Cable .....	11
Supplemental Restraint System (SRS) "AIR BAG" and "SEAT BELT PRE-TENSIONER" .....	2	Installation — Front Passenger Air Bag Module .....	12
<b>SEAT BELTS</b> .....	3	Disposal of Air Bag Module and Seat Belt Pre-tensioner .....	13
Front Seat Belt .....	3	<b>TROUBLE DIAGNOSES — Supplemental Restraint System (SRS)</b> .....	18
Rear Seat Belt .....	4	How to Perform Trouble Diagnoses for Quick and Accurate Repair .....	18
<b>SUPPLEMENTAL RESTRAINT SYSTEM (SRS)</b> .....	5	Schematic .....	21
Precautions for SRS "Air Bag" and "Seat Belt Pre-tensioner" Service .....	5	Wiring Diagram — SRS — .....	22
Special Service Tools .....	5	Self-diagnosis .....	25
Description .....	6	Trouble Diagnoses for Air Bag Warning Lamp .....	39
SRS Component Parts Location .....	6	Trouble Diagnosis for Seat Belt Pre-tensioner .....	41
Maintenance Items .....	7	<b>COLLISION DIAGNOSIS</b> .....	43
Removal and Installation — Diagnosis Sensor Unit and Seat Belt Pre-tensioner .....	8		
Removal — Air Bag Module and Spiral Cable .....	9		
Removal — Front Passenger Air Bag Module .....	10		

**When you read wiring diagrams:**

- Read GI section, "HOW TO READ WIRING DIAGRAMS".
- See EL section, "POWER SUPPLY ROUTING" for power distribution circuit.

**When you perform trouble diagnoses, read GI section, "HOW TO FOLLOW FLOW CHART IN TROUBLE DIAGNOSES" and "HOW TO PERFORM EFFICIENT DIAGNOSIS FOR AN ELECTRICAL INCIDENT".**

## PRECAUTION

---

### **Supplemental Restraint System (SRS) “AIR BAG” and “SEAT BELT PRE-TENSIONER”**

The Supplemental Restraint System “Air Bag” and “Seat Belt Pre-tensioner”, used along with a seat belt, help to reduce the risk or severity of injury to the driver and front passenger in a frontal collision. The Supplemental Restraint System consists of air bag modules (located in the center of the steering wheel and on the instrument panel on the passenger side), seat belt pre-tensioners, a diagnosis sensor unit, warning lamp, wiring harness and spiral cable.

#### **WARNING:**

- **To avoid rendering the SRS inoperative, which could increase the risk of personal injury or death in the event of a collision which would result in air bag inflation, all maintenance must be performed by an authorized INFINITI dealer.**
- **Improper maintenance, including incorrect removal and installation of the SRS, can lead to personal injury caused by unintentional activation of the system.**
- **Do not use electrical test equipment on any circuit related to the SRS unless instructed to in this Service Manual. SRS wiring harnesses are covered with yellow insulation either just before the harness connectors or for the complete harness, for easy identification.**

# SEAT BELTS

## CAUTION:

- Before removing the seat belt assembly, turn the ignition switch off, disconnect both battery cables and wait at least 10 minutes.
- Do not disassemble buckle or seat belt assembly.
- Replace anchor bolts if they are deformed or worn out.
- Never oil tongue and buckle.
- If any component of seat belt assembly is questionable, do not repair. Replace the whole seat belt assembly.
- If webbing is cut, frayed, or damaged, replace seat belt assembly.
- When replacing seat belt assembly, use a genuine seat belt assembly.
- After any collision, inspect all seat belt assemblies, including retractors and other attached hardware (i.e., guide rail set).

## Front Seat Belt

- ① Remove center pillar lower garnish. Refer to "INTERIOR TRIM" in BT section for details.
- ② Disconnect seat belt pre-tensioner connector.
- ③ Remove floor anchor cover and anchor bolt.
- ④ Remove center pillar upper garnish. Refer to "INTERIOR TRIM" in BT section for details.
- ⑤ Pull out seat belt from center pillar upper garnish.
- ⑥ Remove the through anchor nut from adjuster.
- ⑦ Remove bolts securing second sash guide, then remove second sash guide.
- ⑧ Remove the screw securing seat belt pre-tensioner retractor, then remove seat belt and seat belt pre-tensioner retractor.

GI  
VA  
EM  
LC  
FC  
FE  
AT  
PD  
FA  
RA  
BR  
ST  
RS  
BT  
HA  
EL  
IDX

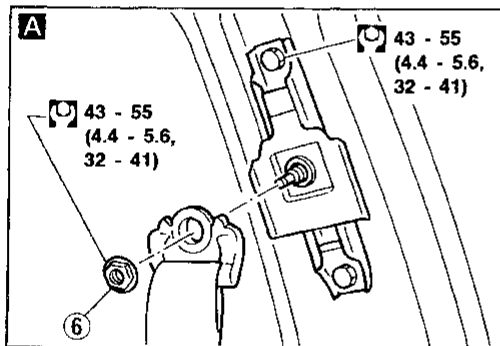

SEC. 769-868

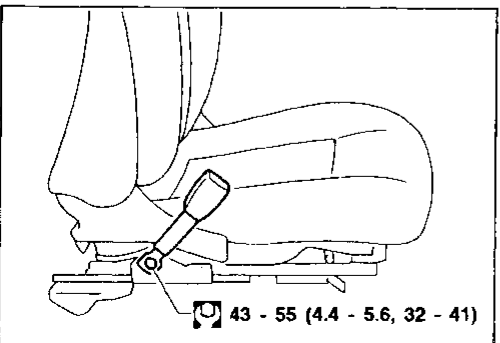
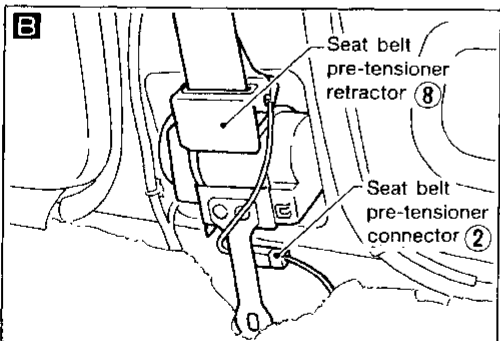
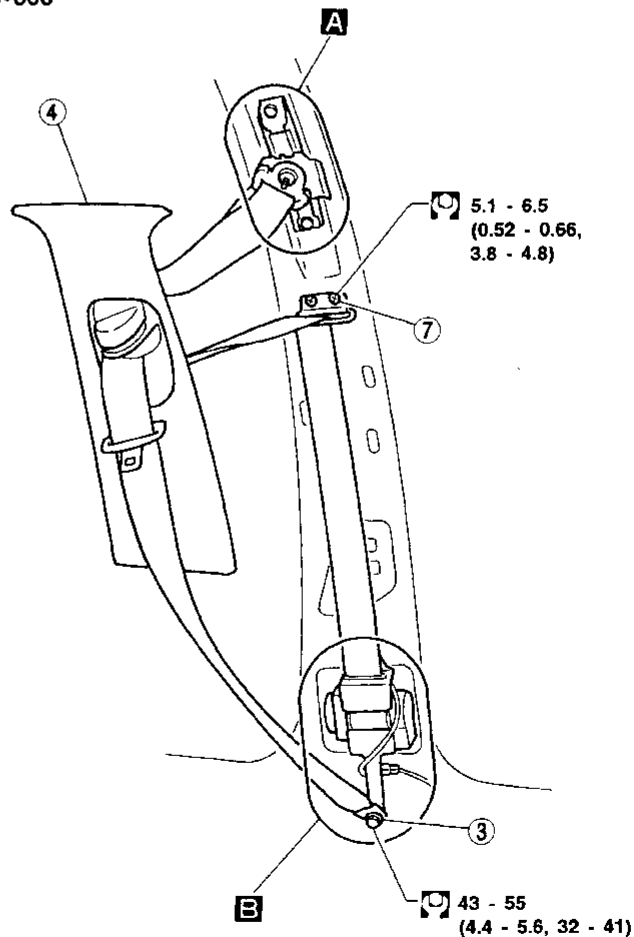

: N·m (kg-m, ft-lb)

MRS003AA

# SEAT BELTS

## Rear Seat Belt

- ① Remove rear seat. Refer to "SEAT" in BT section for details.
- ② Remove rear pillar garnish. Refer to "INTERIOR TRIM" in BT section for details.
- ③ Remove each anchor bolt.
- ④ Remove trunk room side finisher. Refer to "INTERIOR TRIM" in BT section for details.
- ⑤ Remove the bolt securing rear seat belt retractor.

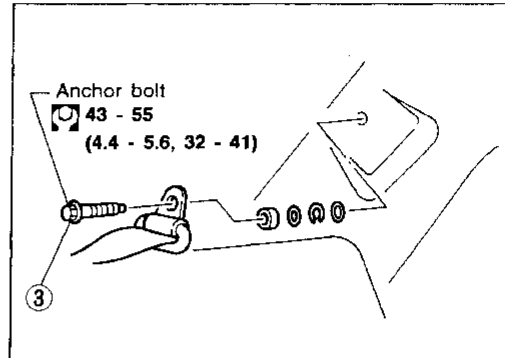
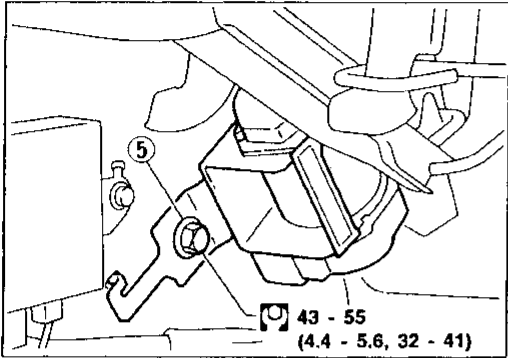

SEC. 869

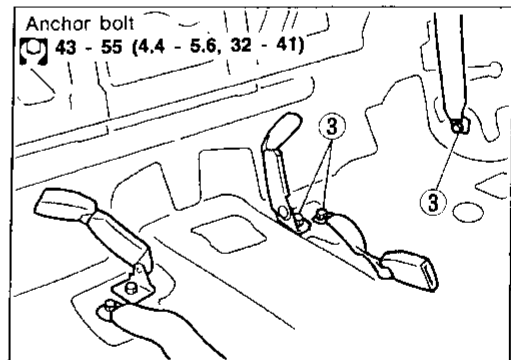
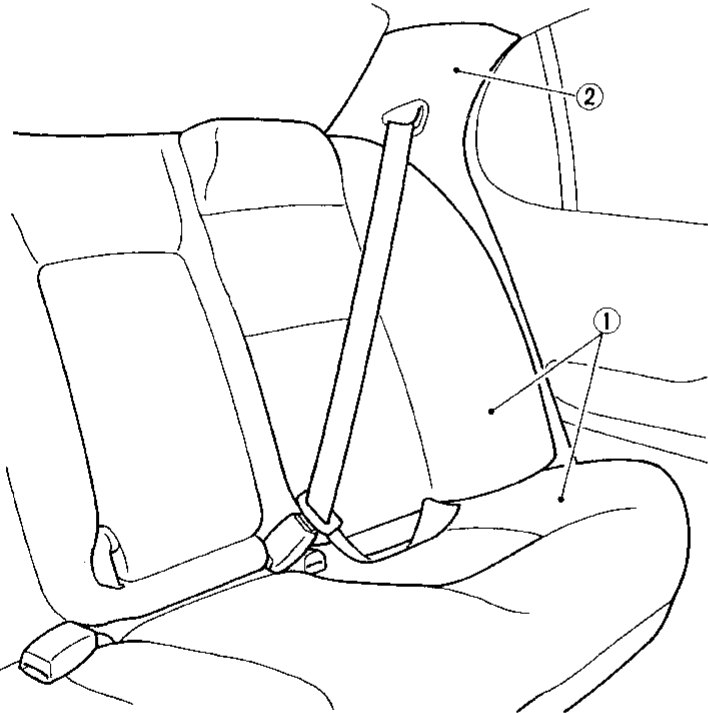

$\text{N}\cdot\text{m}$  (kg-m, ft-lb)

# SUPPLEMENTAL RESTRAINT SYSTEM (SRS)

## Precautions for SRS "Air Bag" and "Seat Belt Pre-tensioner" Service

- Do not use a circuit tester to check SRS circuits.
- Before servicing the SRS, turn ignition switch "OFF", disconnect both battery cables and wait at least 10 minutes.  
For approximately 10 minutes after the cables are removed, it is still possible for the air bag and seat belt pre-tensioner to deploy. Therefore, do not work on any SRS connectors or wires until at least 10 minutes have passed.
- Diagnosis sensor unit must always be installed with their arrow marks "←" pointing towards the front of the vehicle for proper operation. Also check diagnosis sensor unit for cracks, deformities or rust before installation and replace as required.
- The spiral cable must be aligned with the neutral position since its rotations are limited. Do not attempt to turn steering wheel or column after removal of steering gear.
- Handle air bag module carefully. Always place it with the pad side facing upward.
- Do not use old bolts after removing any SRS parts; replace with new ones. Conduct self-diagnosis to check entire SRS for proper function.
- After air bag inflates, the front instrument panel assembly should be replaced.

## Special Service Tools

The actual shapes of Kent-Moore tools may differ from those of special service tools illustrated here.

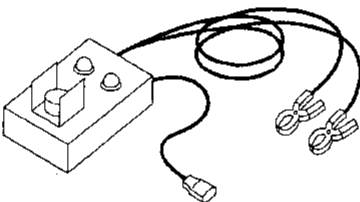
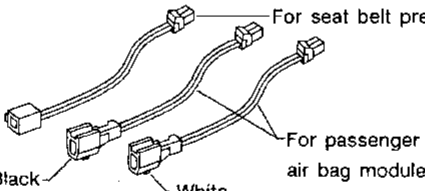
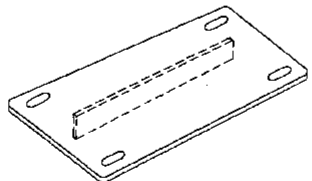
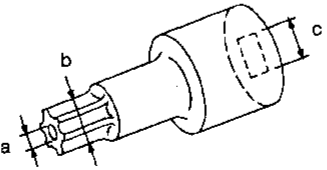
Tool number (Kent-Moore No.) Tool name	Description
KV991072S0 (J38381-KIT) Air bag deployment kit  KV99106400 (J38381) Deployment tool	Disposing of air bag module   NT357
KV991065S0 (J38381-30) Deployment tool adapters	For seat belt pre-tensioner For passenger air bag module   NT353
KV99105300 (J41246) Passenger air bag bracket	Anchor the passenger air bag module   NT354
HT61961000 and HT62152000 combined (J38219) *Special torx bit	Use for special bolts [TAMPER RESISTANT TORX (Size T50)]   NT361  a: 3.5 (0.138) dia. b: 8.5 - 8.6 (0.335 - 0.339) dia. c: approx. 10 (0.39) sq.  Unit: mm (in)

\*: Special tool or commercial equivalent

# SUPPLEMENTAL RESTRAINT SYSTEM (SRS)

## Description

The air bag deploys if the diagnosis sensor unit activates while the ignition switch is in "ON" or "START" position.

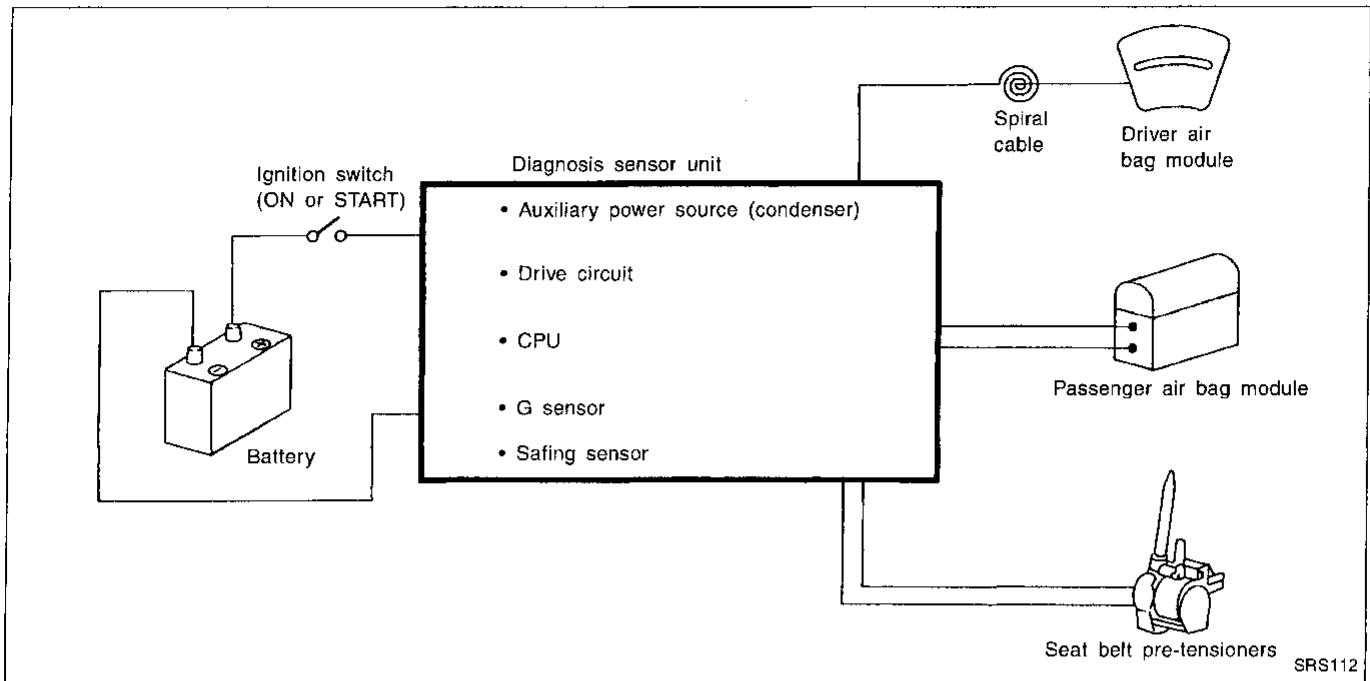

## SRS Component Parts Location

SEC. 251-253-484-680-868

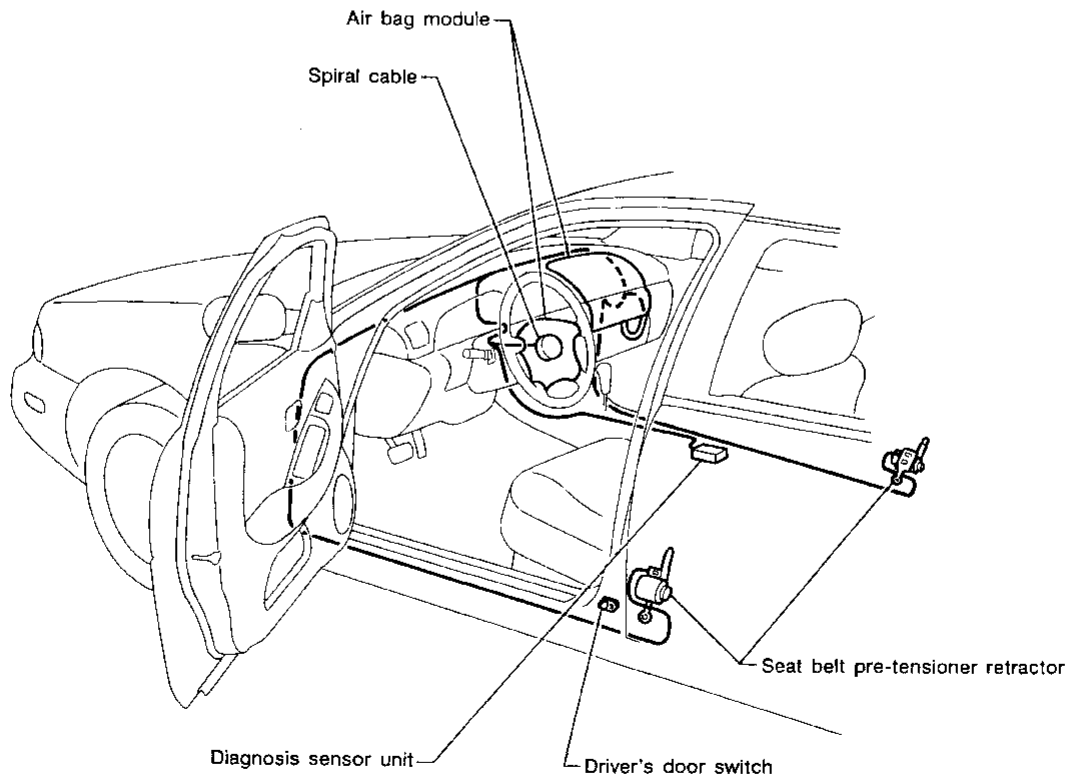

MRS005AA

# SUPPLEMENTAL RESTRAINT SYSTEM (SRS)

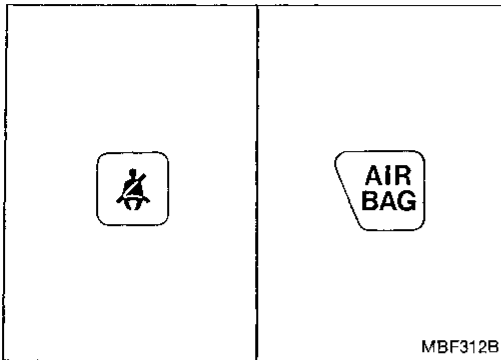

## Maintenance Items

1. Check operation of "AIR BAG" and "SEAT BELT" warning lamps

After turning ignition key to "ON" position, both warning lamps illuminate. The "AIR BAG" warning lamp will go off after about 7 seconds if no malfunction is detected. The "SEAT BELT" warning lamp will also go off after about 7 seconds after seat belt has been fastened and no malfunction is detected. (When seat belt has not been fastened, the warning lamp continues to illuminate until seat belt is fastened.)

If any of the following warning lamp conditions occur, immediately check the air bag or seat belt pre-tensioner system. Refer to RS-25 or RS-26 for details.

- The "AIR BAG" or "SEAT BELT" warning lamp does not illuminate when the ignition switch is turned "ON".
- The "AIR BAG" or "SEAT BELT" (with seat belt fastened) warning lamp does not go off about 7 seconds after the ignition switch is turned "ON".
- The "AIR BAG" or "SEAT BELT" (with seat belt fastened) warning lamp goes off about 7 seconds after the ignition switch is turned "ON", but comes on again or flashes.

2. Visually check SRS components

- (1) Diagnosis sensor unit

- Check diagnosis sensor unit and bracket for dents, cracks or deformities.
- Check connectors for damage, and terminals for deformities.

- (2) Air bag module and steering wheel

- Remove air bag module from steering wheel or instrument panel. Check harness cover and connectors for damage, terminals for deformities, and harness for binding.
- Install driver side air bag module to steering wheel to check fit or alignment with the wheel.
- Check steering wheel for excessive free play.
- Install passenger side air bag module to instrument panel to check fit or alignment with the instrument panel.

- (3) Spiral cable

- Check spiral cable for dents, cracks, or deformities.
- Check connectors and protective tape for damage.
- Check steering wheel for noise, binding or heavy operation.

- (4) Main harness and air bag harness

- Check connectors for poor connections, damage, and terminals for deformities.
- Check harnesses for binding, chafing or cut.

### CAUTION:

Replace previously used screws with new ones.

- (5) Seat belt pre-tensioner

- Check harness cover and connectors for damage, terminals for deformities, and harness for binding.
- Check belts for damage and anchors for loose mounting.

## SUPPLEMENTAL RESTRAINT SYSTEM (SRS)

### Maintenance Items (Cont'd)

- Check retractor for smooth operation.
- Perform self-diagnosis for seat belt pre-tensioner using seat belt warning lamp or CONSULT. Refer to "Self-diagnosis" for details. (RS-25)

### Removal and Installation — Diagnosis Sensor Unit and Seat Belt Pre-tensioner

#### CAUTION:

- Before servicing SRS, turn the ignition switch off, disconnect both battery cables and wait at least 10 minutes.
- The special bolts are coated with bonding agent while the other bolt is for ground. Do not use old bolts after removal; replace with new ones.
- Check diagnosis sensor unit for proper installation.
- Check diagnosis sensor unit to ensure they are free of deformities, dents, cracks or rust. If they show any visible signs of damage, replace them with new ones.
- Check diagnosis sensor unit brackets to ensure they are free of deformities or rust.
- Replace diagnosis sensor unit if it has been dropped or sustained an impact.
- Do not attempt to disassemble seat belt pre-tensioner.
- Do not drop or impact seat belt pre-tensioner. If any portion is damaged, replace the seat belt pre-tensioner.
- Do not expose seat belt pre-tensioner to temperatures exceeding 80°C (176°F).
- Whenever seat belts (equipped with pre-tensioner) are moved, ensure that cylinder faces down. Do not hold cylinder.

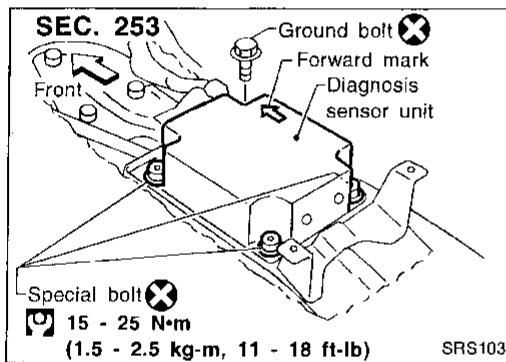

#### REMOVAL OF DIAGNOSIS SENSOR UNIT

1. Disconnect driver and passenger air bag module connectors. Also, disconnect seat belt pre-tensioner connector.
  2. Remove lower instrument center panel. Refer to "INSTRUMENT PANEL" in BT section.
  3. Disconnect diagnosis sensor unit connector.
  4. Remove bolt and also remove special bolts using the TAMPER RESISTANT TORX (Size T50), from diagnosis sensor unit.
- Then remove the diagnosis sensor unit.

#### NOTE:

- To install, reverse the removal procedure sequence.
- After replacement, perform self-diagnosis for SRS. Refer to "Self-diagnosis" for details. (RS-25)

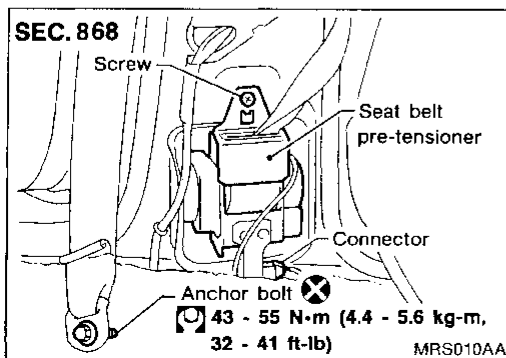

#### REMOVAL OF SEAT BELT PRE-TENSIONER

For removal of seat belt pre-tensioner, refer to "Front Seat Belt" for details. (RS-3)

#### NOTE:

- To install, reverse the removal procedure sequence.
- After replacement, perform self-diagnosis for seat belt pre-tensioner. Refer to "Self-diagnosis" for details. (RS-26)



Removal — Air Bag Module and Spiral Cable

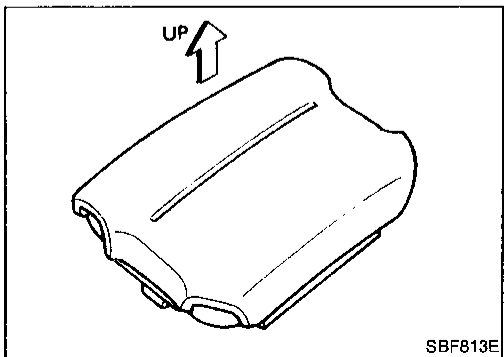
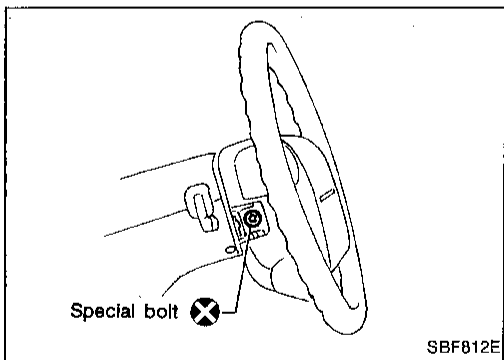
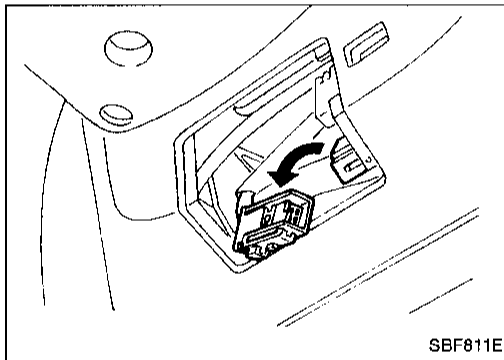
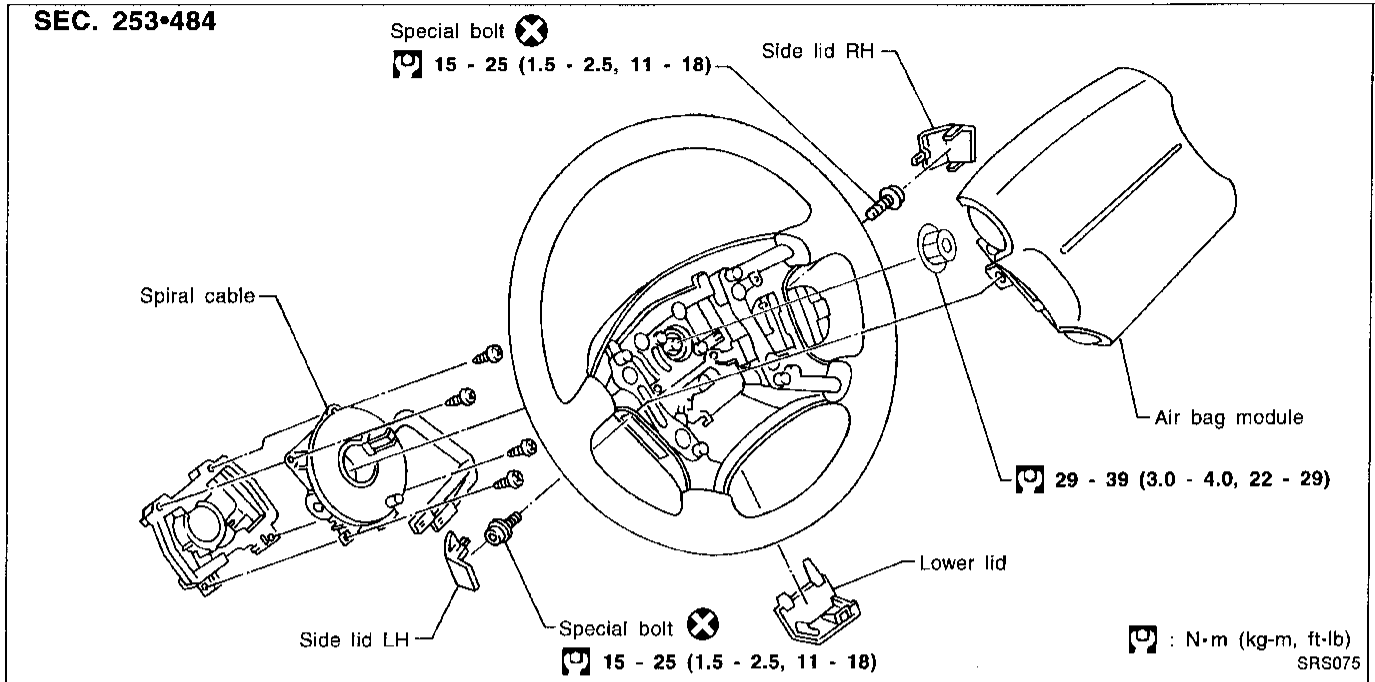

CAUTION:

- Before servicing SRS, turn the ignition switch off, disconnect both battery cables and wait at least 10 minutes.
  - Always work from the side of air bag module.
1. Remove lower lid from steering wheel, and disconnect air bag module connector.
  2. Remove side lid. Using the TAMPER RESISTANT TORX (Size T50), remove left and right special bolts. Air bag module can then be removed.

CAUTION:

- Always place air bag module with pad side facing upward.
- Do not attempt to disassemble air bag module.
- The special bolts are coated with bonding agent. Do not use old bolts after removal; replace with new ones.

GI  
MA  
EM  
LC  
EC  
FE  
AT

PD  
FA  
RA  
BR

ST

RS

BT

HA

EL

IDX

## SUPPLEMENTAL RESTRAINT SYSTEM (SRS)

### Removal — Air Bag Module and Spiral Cable (Cont'd)

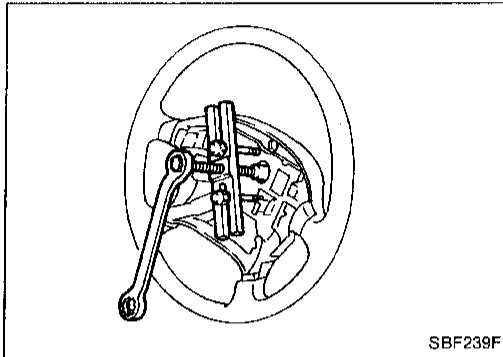
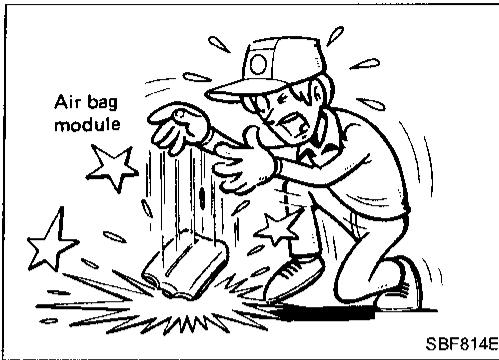

- Replace air bag module if it has been dropped or sustained an impact.
- Do not expose the air bag module to temperatures exceeding 90°C (194°F).
- Do not allow oil, grease or water to come in contact with the air bag module.

3. Set steering wheel in the neutral position.
4. Disconnect horn connector and remove nuts.
5. Using steering wheel puller, remove steering wheel. Be careful not to over-tighten puller bolt on steering wheel.
6. Remove steering column cover.
7. Disconnect connector and remove the four screws. The spiral cable can then be removed.

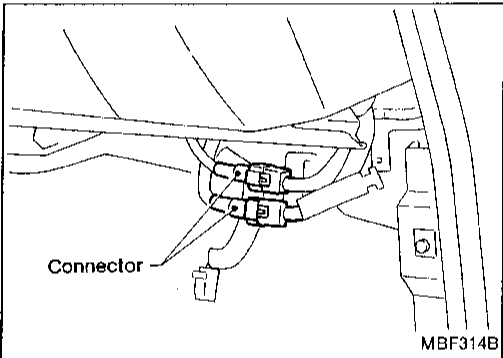

### Removal — Front Passenger Air Bag Module

#### CAUTION:

- Before servicing SRS, turn the ignition switch off, disconnect both battery cables and wait at least 10 minutes.
- Always work from the side of or under air bag module.

1. Remove lower instrument cover on passenger side.
2. Remove connector bracket from air bag module and disconnect inflator connector from body harness air bag connector.

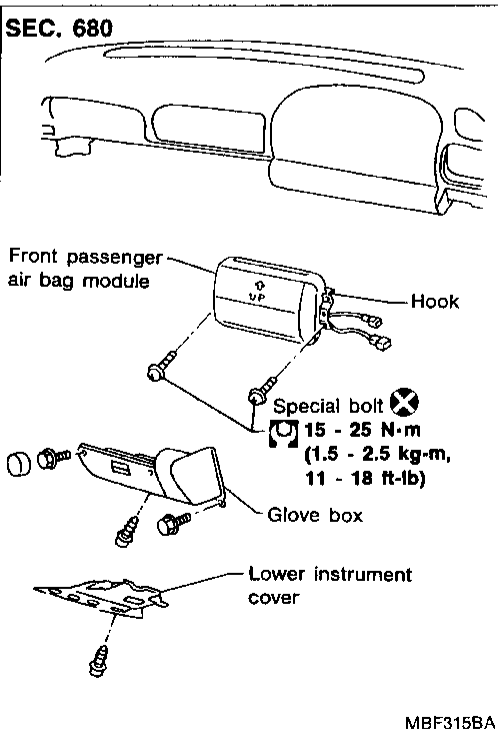

3. Remove glove box assembly.
  4. Remove the special bolt from left and right sides of front passenger air bag module and remove the air bag module.
- Air bag module is heavy and should be supported using both hands during removal.

## SUPPLEMENTAL RESTRAINT SYSTEM (SRS)

### Removal — Front Passenger Air Bag Module (Cont'd)

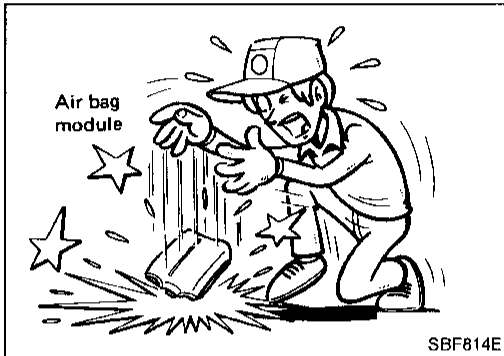
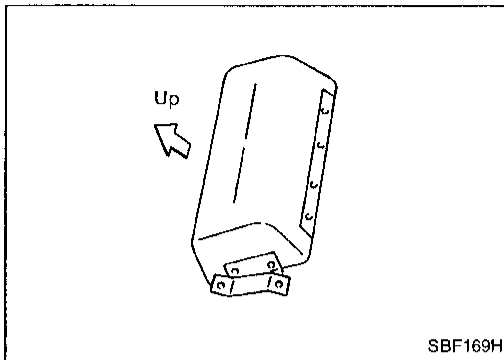

#### CAUTION:

- Always place air bag module with pad side facing upward.
- Do not attempt to disassemble air bag module.
- The special bolts are coated with bonding agent. Do not use old bolts after removal; replace with new coated bolts.

- Replace air bag module if it has been dropped or sustained an impact.
- Do not expose the air bag module to temperatures exceeding 90°C (194°F).
- Do not allow oil, grease or water to come in contact with the air bag module.

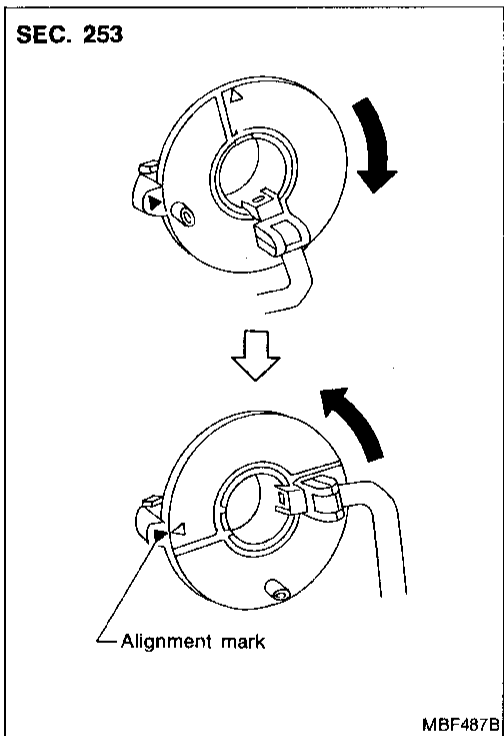

### Installation — Air Bag Module and Spiral Cable

1. Set the front wheels in the straight-ahead position.
2. Make sure that the spiral cable is in the neutral position. The neutral position is detected by turning left about 2.5 revolutions from the right end position. Align the two marks (Δ).

#### CAUTION:

- The spiral cable may snap due to steering operation if the cable is installed in an improper position.
  - Also, with the steering linkage disconnected, the cable may snap by turning the steering wheel beyond the limited number of turns. (The spiral cable can be turned up to 2.5 turns from the neutral position to both the right and left.)
  - Always work from the side of air bag module.
3. Connect spiral cable connector and tighten with screws. Install steering column cover.

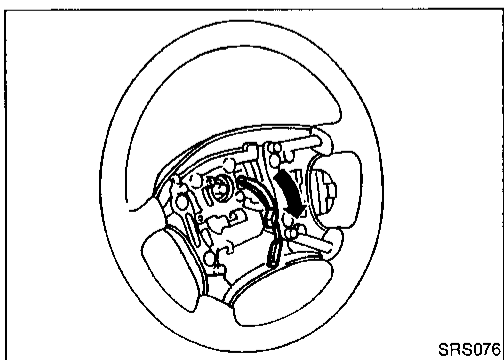

4. Install steering wheel setting spiral cable pin guides, and pull spiral cable through.
5. Connect horn connector and engage spiral cable with pawls in steering wheel. Move air bag module connector away from steering wheel lower lid opener.
6. Tighten nut.

: 29 - 39 N·m (3.0 - 4.0 kg-m, 22 - 29 ft-lb)

## SUPPLEMENTAL RESTRAINT SYSTEM (SRS)

### Installation — Air Bag Module and Spiral Cable (Cont'd)

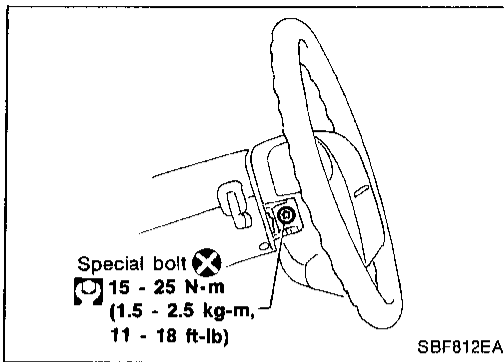

7. Position air bag module and tighten with new special bolts.
8. Connect air bag module connector.
9. Install all lids.
10. Conduct self-diagnosis to ensure entire SRS operates properly. (Use CONSULT or warning lamp check.)  
Before performing self-diagnosis, connect both battery cables.

11. Turn steering wheel to the left end and then to the right end fully to make sure that spiral cable is set in the neutral position.

If air bag warning lamp blinks or stays ON (at the user mode), it shows the spiral cable may be snapped due to its improper position. Perform self-diagnosis again (use CONSULT or warning lamp). If a malfunction is detected, replace the spiral cable with a new one.

### SEC. 680

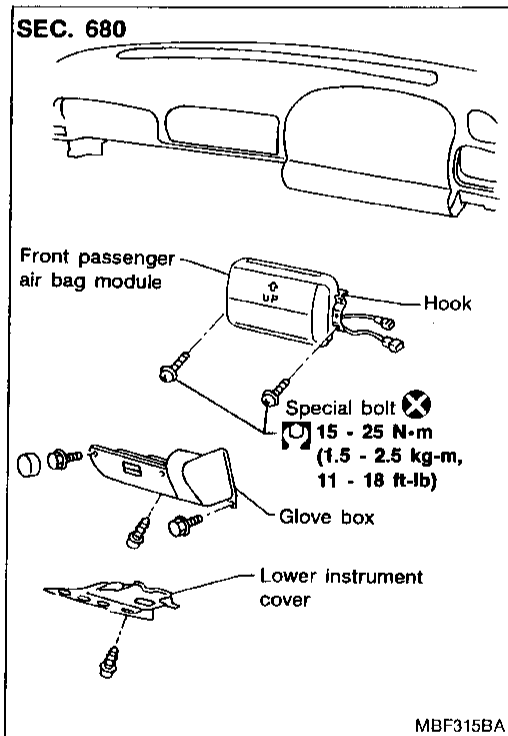

### Installation — Front Passenger Air Bag Module

- Always work from the side of or under air bag module.
1. Install front passenger air bag module.
  - Ensure harness is not caught between rear of air bag module and steering member.
  2. Install glove box assembly.

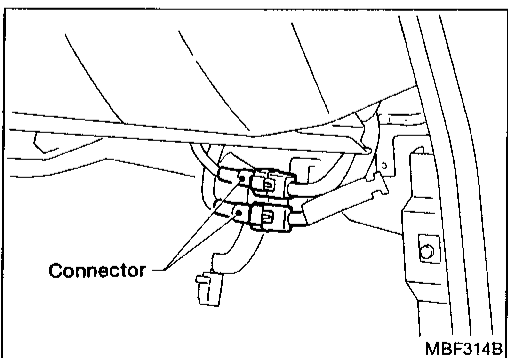

3. Connect air bag module connector to body harness connector.
4. Install air bag module connector on connector bracket.
5. Install connector bracket on air bag module, then install lower instrument cover on passenger side.

**Disposal of Air Bag Module and Seat Belt Pre-tensioner**

- Before disposing of air bag module and seat belt pre-tensioner, or vehicles equipped with such systems, deploy the systems. If such systems have already been deployed due to an accident, dispose of as indicated in "DISPOSING OF AIR BAG MODULE AND SEAT BELT PRE-TENSIONER" (RS-17).
- When deploying the air bag module and seat belt pre-tensioner, always use the Special Service Tool; Deployment tool KV99106400 (Kent-Moore No. J38381).
- When deploying the air bag module and seat belt pre-tensioner, stand at least 5 m (16 ft) away from the deployment component.
- Due to heat, leave air bag module unattended for more than 30 minutes after deployment. Also leave seat belt pre-tensioner unattended for more than 10 minutes after deployment.
- Be sure to wear gloves when handling a deployed air bag module and seat belt pre-tensioner.
- Never apply water to a deployed air bag module and seat belt pre-tensioner.
- Wash your hands clean after finishing work.

GI  
MA  
EM  
LC  
EC  
FE  
AT  
PD  
FA  
RA  
BR  
ST  
RS  
BT  
HA  
EL  
IDX

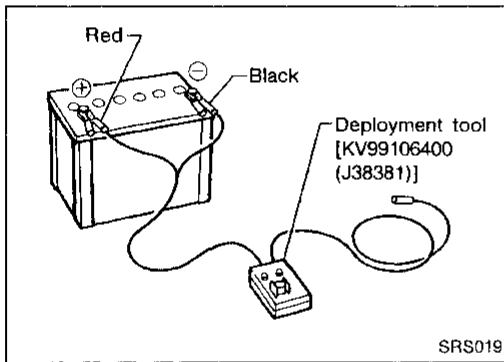

**CHECKING DEPLOYMENT TOOL**

**Connecting to battery**

- Place the vehicle outdoors with an open space of at least 6 m (20 ft) on all sides.
- Use a voltmeter to make sure the vehicle battery is fully charged.

**CAUTION:**

**The battery must show voltage of 9.6V or more.**

Remove the battery from the vehicle and place it on dry wood blocks approximately 5 m (16 ft) away from the vehicle.

- Wait 10 to 12 minutes after the vehicle battery is disconnected before proceeding.
- Connect red clip of deployment tool to battery positive terminal and black clip to negative terminal.

**Make sure the polarity is correct. The right side lamp in the tool, marked "deployment tool power", should glow with a green light. If the right side lamp glows red, reverse the connections to the battery.**

## SUPPLEMENTAL RESTRAINT SYSTEM (SRS)

### Disposal of Air Bag Module and Seat Belt Pre-tensioner (Cont'd)

#### Deployment tool check

Press the deployment tool switch to the "ON" position. The left side lamp in the tool, marked "air bag connector voltage" should illuminate. If it does not illuminate, replace the tool.

#### Air bag deployment tool lamp illumination chart (Battery connected)

Switch operation	Left side lamp, green* "AIR BAG CONNECTOR VOLTAGE"	Right side lamp, green* "DEPLOYMENT TOOL POWER"
OFF	OFF	ON
ON	ON	ON

\*: If this lamp glows red, the tool is connected to the battery incorrectly. Reverse the connections and make sure the lamp glows green.

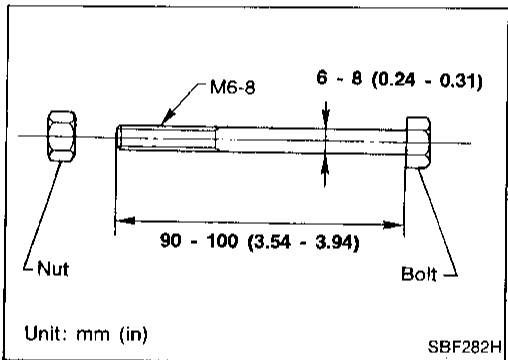
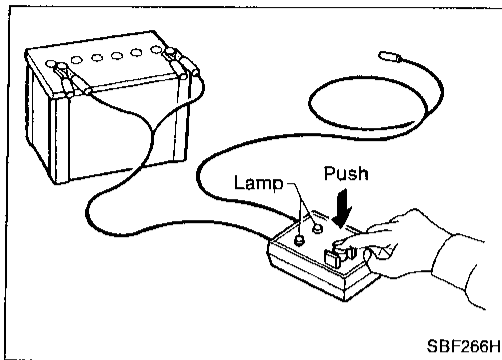

### DEPLOYMENT PROCEDURES FOR AIR BAG MODULE AND SEAT BELT PRE-TENSIONER (OUTSIDE OF VEHICLE)

Deploying air bag module and seat belt pre-tensioner while mounted in vehicle may damage the vehicle. Deploy air bag module and seat belt pre-tensioner as a unit except when disposing of vehicle.

Anchor air bag module and seat belt pre-tensioner in a vise secured to a firm foundation during deployment.

#### Deployment of driver's air bag module (outside of vehicle)

1. Prepare two sets of nuts and bolts (see figure at left). These bolts are required to secure driver's air bag module to the vise.
2. Install one set of nuts and bolts to each side of the air bag module.

#### CAUTION:

**Make sure to install two bolts and nuts on each side.**

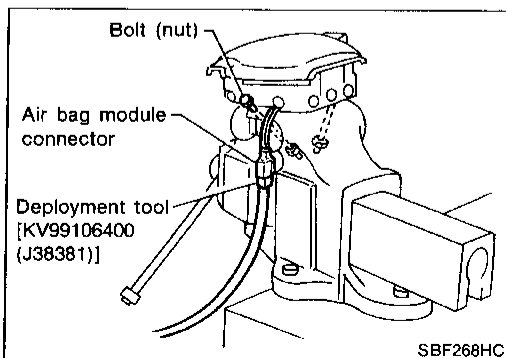
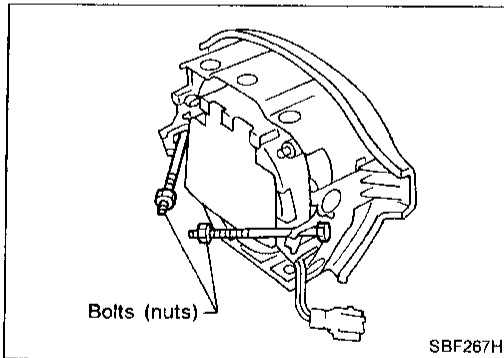

3. Firmly place two nuts (secured to air bag module) in the vise.

#### CAUTION:

**Ensure these two nuts are equally placed in the vise. Never finish the installation with just one nut.**

4. Connect deployment tool [SST: KV99106400 (J38381)] to air bag module connector.

## SUPPLEMENTAL RESTRAINT SYSTEM (SRS)

### Disposal of Air Bag Module and Seat Belt Pre-tensioner (Cont'd)

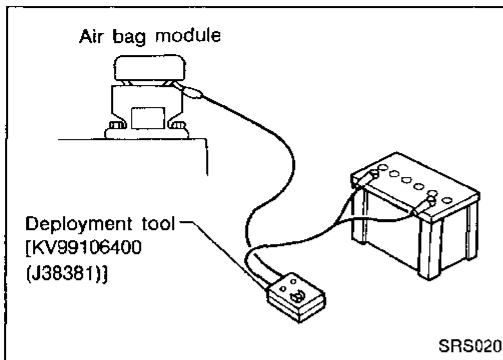

5. Connect red clip of deployment tool to battery positive terminal and black clip to negative terminal.
6. The lamp on the right side of the tool, marked "deployment tool power", should glow green, not red.
7. Press the button on the deployment tool. The left side lamp on the tool, marked "air bag connector voltage", will illuminate and the air bag module will deploy.

#### CAUTION:

When deploying the air bag module, stand at least 5 m (16 ft) away from the air bag module.

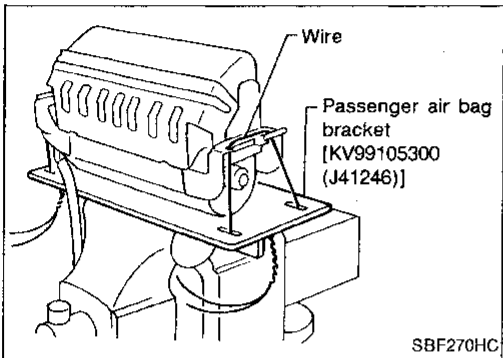

### Deployment of passenger air bag module (outside of vehicle)

1. Using wire, secure air bag module to passenger air bag bracket [SST: KV99105300 (J41246)] at two places.

#### CAUTION:

Use wire of at least 1 mm (0.04 in) in diameter.

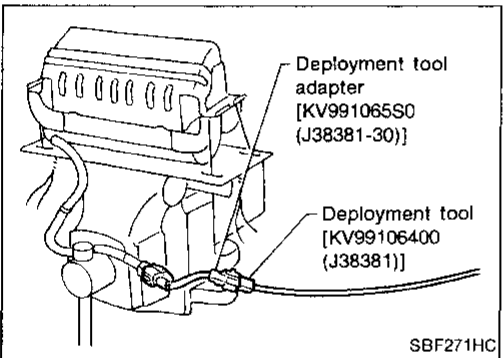

2. Firmly anchor passenger air bag bracket in a vise.
3. Connect deployment tool adapter [SST:KV991065S0 (J38381-30)] to deployment tool [SST: KV99106400 (J38381)] connector and connector on either side of air bag module.
4. Connect red clip of deployment tool to battery positive terminal and black clip to negative terminal.
5. The lamp on the right side of the tool, marked "deployment tool power", should glow green, not red.
6. Press the button on the deployment tool. The left side lamp on the tool, marked "air bag connector voltage", will illuminate and the air bag module will deploy.

#### CAUTION:

When deploying the air bag module, stand at least 5 m (16 ft) away from the air bag module.

7. Activate the other inflator.

#### CAUTION:

Always activate one inflator at a time.

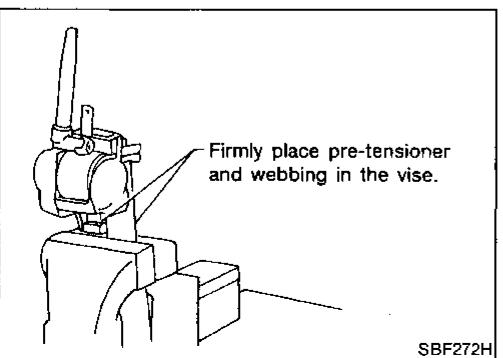
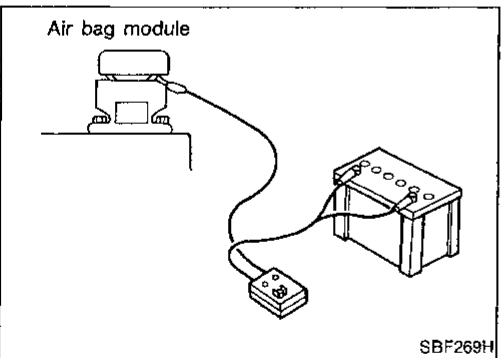

### Deployment of seat belt pre-tensioner (outside of vehicle)

1. Firmly anchor seat belt pre-tensioner in a vise.

#### CAUTION:

Ensure bracket and webbing are placed in the vise.

## SUPPLEMENTAL RESTRAINT SYSTEM (SRS)

### Disposal of Air Bag Module and Seat Belt Pre-tensioner (Cont'd)

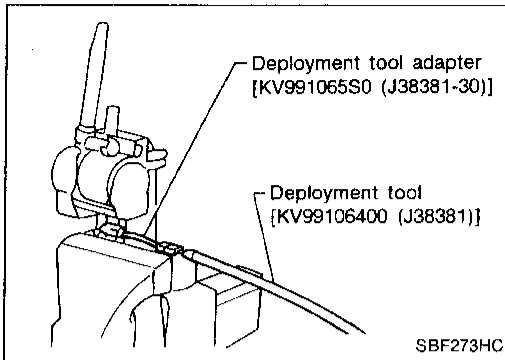

2. Connect deployment tool adapter [SST:KV991065S0 (J38381-30)] to deployment tool [SST: KV99106400 (J38381)] connector and seat belt pre-tensioner connector.

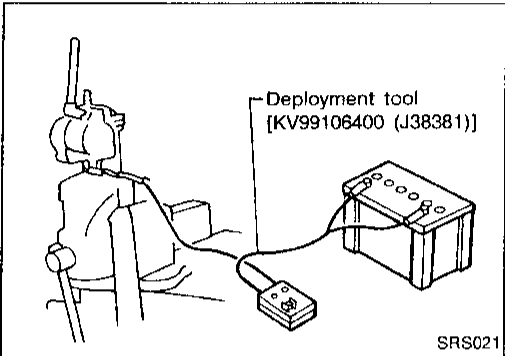

3. Connect red clip of deployment tool to battery positive terminal and black clip to negative terminal.
4. The lamp on the right side of the tool, marked "deployment tool power", should glow green, not red.
5. Press the button on the deployment tool. The left side lamp on the tool, marked "seat belt pre-tensioner connector voltage", will illuminate and the seat belt pre-tensioner will deploy.

#### CAUTION:

When deploying the seat belt pre-tensioner, stand at least 5 m (16 ft) away from the seat belt pre-tensioner.

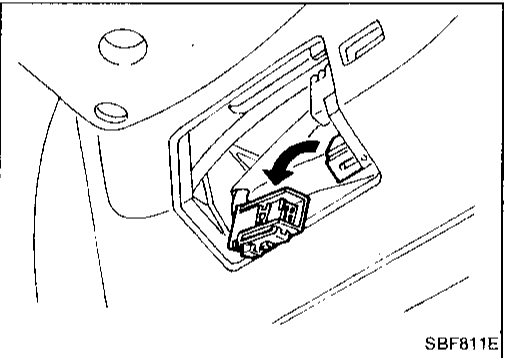

### DEPLOYMENT OF AIR BAG MODULE AND SEAT BELT PRE-TENSIONER WHILE MOUNTED IN VEHICLE

When disposing of a vehicle, deploy air bag modules and seat belt pre-tensioners while they are mounted in vehicle.

#### CAUTION:

When deploying air bag module or seat belt pre-tensioner, ensure vehicle is empty.

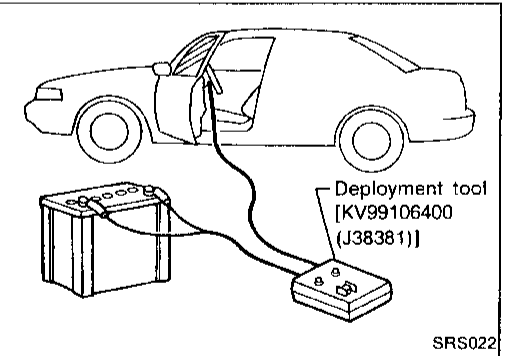

1. Disconnect the vehicle battery ground cable and wait 10 minutes.
2. Disconnect air bag modules and seat belt pre-tensioners connector.
3. Connect deployment tool [SST: KV99106400 (J38381)] to air bag module or seat belt pre-tensioner. For front passenger air bag module and seat belt pre-tensioner, attach deployment tool adapters [SST: KV991065S0 (J38381-30)] to the tool connector.
4. Connect red clip of deployment tool to battery positive terminal and black clip to negative terminal.
5. The lamp on the right side of the tool, marked "deployment tool power", should glow green, not red.
6. Press the button on the deployment tool. The left side lamp on the tool, marked "air bag connector voltage", will illuminate and the air bag module or seat belt pre-tensioner will deploy.

#### CAUTION:

Activate only one passenger air bag module inflator at a time.



## SUPPLEMENTAL RESTRAINT SYSTEM (SRS)

### Disposal of Air Bag Module and Seat Belt Pre-tensioner (Cont'd)

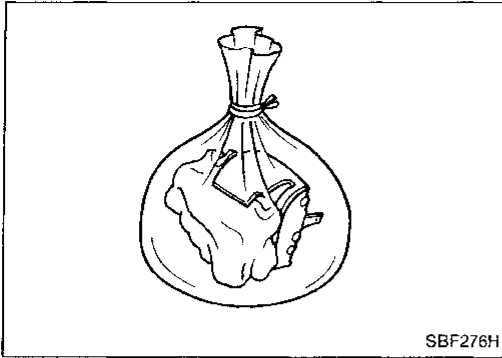

#### DISPOSING OF AIR BAG MODULE AND SEAT BELT PRE-TENSIONER

Deployed air bag modules and seat belt pre-tensioners are very hot. Before disposing of air bag module, and seat belt pre-tensioner, wait at least 30 minutes, and 10 minutes, respectively. Seal them in a plastic bag before disposal.

#### CAUTION:

- Never apply water to a deployed air bag module and seat belt pre-tensioner.
- Be sure to wear gloves when handling a deployed air bag module and seat belt pre-tensioner.
- No poisonous gas is produced upon air bag module deployment. However, be careful not to inhale gas since it irritates throat and can cause choking.
- Do not attempt to disassemble air bag module and seat belt pre-tensioner.
- Air bag module and seat belt pre-tensioner cannot be re-used.
- Wash your hands clean after finishing work.

GI

MA

EM

LC

EC

FE

AT

PD

FA

RA

BR

ST

**RS**

BT

HA

EL

IDX

## How to Perform Trouble Diagnoses for Quick and Accurate Repair

A good understanding of the malfunction conditions can make troubleshooting faster and more accurate. In general, each customer feels differently about a problem. It is important to fully understand the symptoms or conditions for a customer complaint.

### INFORMATION FROM CUSTOMER

WHAT ..... Vehicle model  
WHEN ..... Date, Frequencies  
WHERE ..... Road conditions  
HOW ..... Operating conditions, Symptoms

### PRELIMINARY CHECK

Check that the following parts are in good order.

- Battery [Refer to MA section (“GENERAL MAINTENANCE”).]
- Fuse [Refer to EL section (“Fuse”, “POWER SUPPLY ROUTING”).]
- System component-to-harness connections

### DIAGNOSIS FUNCTION

The SRS self-diagnosis results can be read by using “AIR BAG” warning lamp, “SEAT BELT” warning lamp and/or CONSULT. The reading of these results is accomplished using one of two modes — “User mode” and “Diagnosis mode”.

The User mode is exclusively prepared for the customer (driver). This mode warns the driver of a system malfunction through the operation of the “AIR BAG” warning lamp and/or “SEAT BELT” warning lamp.

The Diagnosis mode allows the technician to locate and inspect the malfunctioning part.

The mode applications for the “AIR BAG” warning lamp, “SEAT BELT” warning lamp and CONSULT are as follows:

	User mode	Diagnosis mode	Display type
“AIR BAG” warning lamp	X	X	ON-OFF operation
“SEAT BELT” warning lamp	X	—	ON-OFF operation
CONSULT	—	X	Monitoring

### DIAGNOSIS MODE FOR CONSULT

- SELF-DIAG [CURRENT]  
A current Self-diagnosis result (also indicated by the number of warning lamp flashes in the Diagnosis mode) is displayed on the CONSULT screen in real time. This refers to a malfunctioning part requiring repairs.
- SELF-DIAG [PAST]  
Diagnosis results previously stored in the memory (also indicated by the warning lamp flashes in the User mode) are displayed on the CONSULT screen. The stored results are not erased until memory erasing is executed.

## How to Perform Trouble Diagnoses for Quick and Accurate Repair (Cont'd)

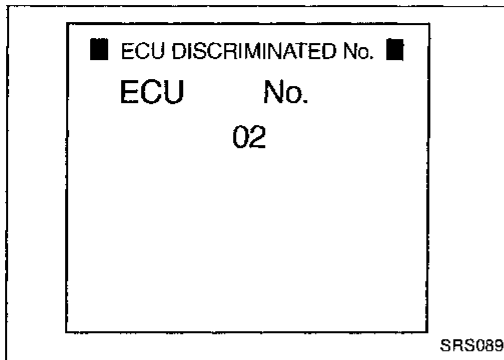

- ECU DISCRIMINATED NO.  
The diagnosis sensor unit for each vehicle model is assigned with its own, individual classification number. This number will be displayed on the CONSULT screen, as shown at left. When replacing the diagnosis sensor unit, refer to the part number for the compatibility. After installation, replacement with a correct unit can be checked by confirming this classification number on the CONSULT screen.

**For INFINITI J30, the diagnosis sensor unit classification number assigned is 02.**

GI

MA

EM

LC

EC

FE

AT

PD

FA

RA

BR

ST

**RS**

BT

HA

EL

DX

# TROUBLE DIAGNOSES — Supplemental Restraint System (SRS)

## How to Perform Trouble Diagnoses for Quick and Accurate Repair (Cont'd)

**CAUTION:**

- Do not use a circuit tester to check SRS harness connectors unless instructed to in this Service Manual. SRS wiring harnesses are covered with yellow insulation either just before the harness connectors or for the complete harness, for easy identification.
- Do not attempt to repair, splice or modify the SRS wiring harness. If the harness is damaged, replace it with a new one.
- Keep ground portion clean.

**WORK FLOW**

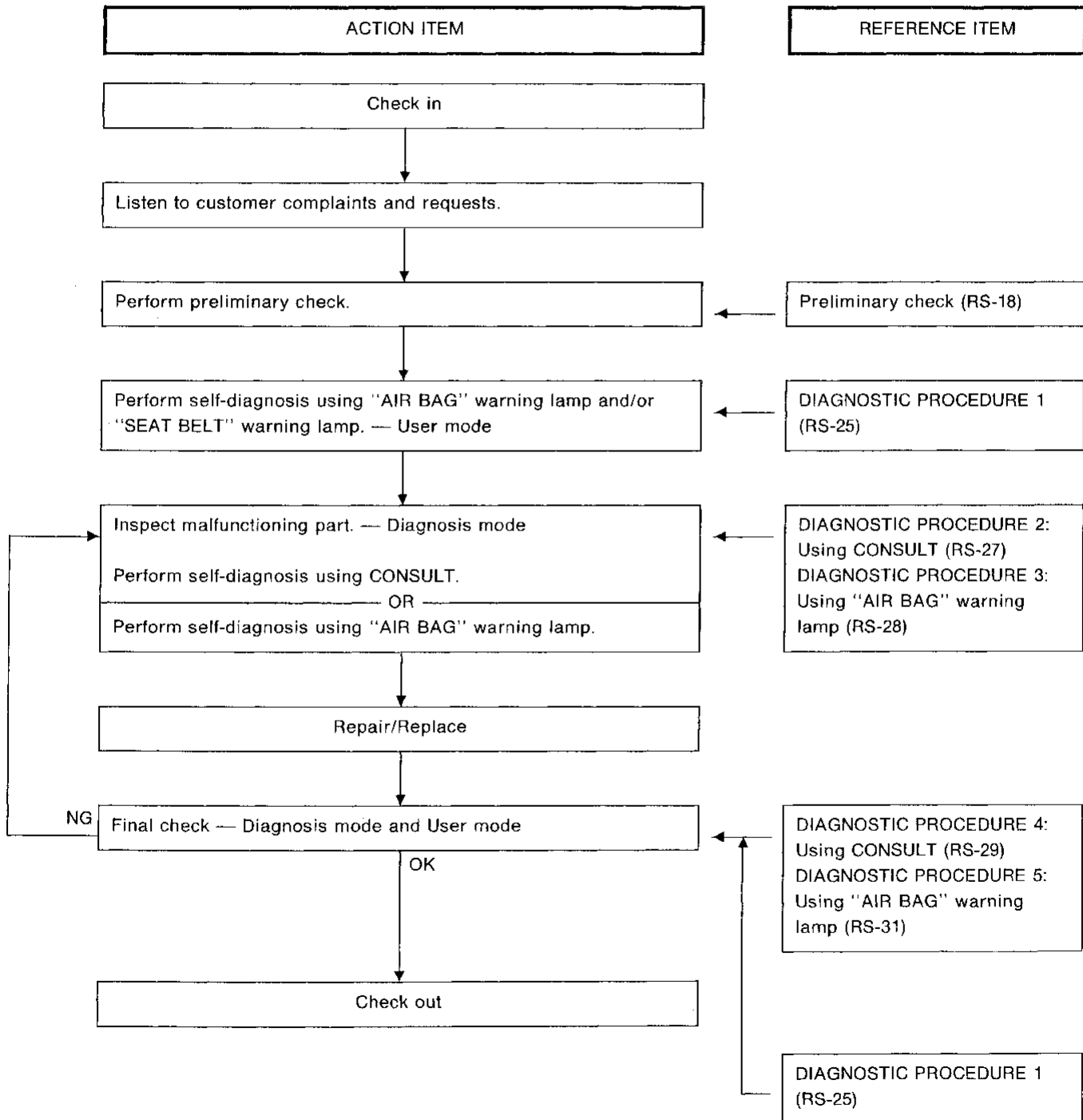

Schematic

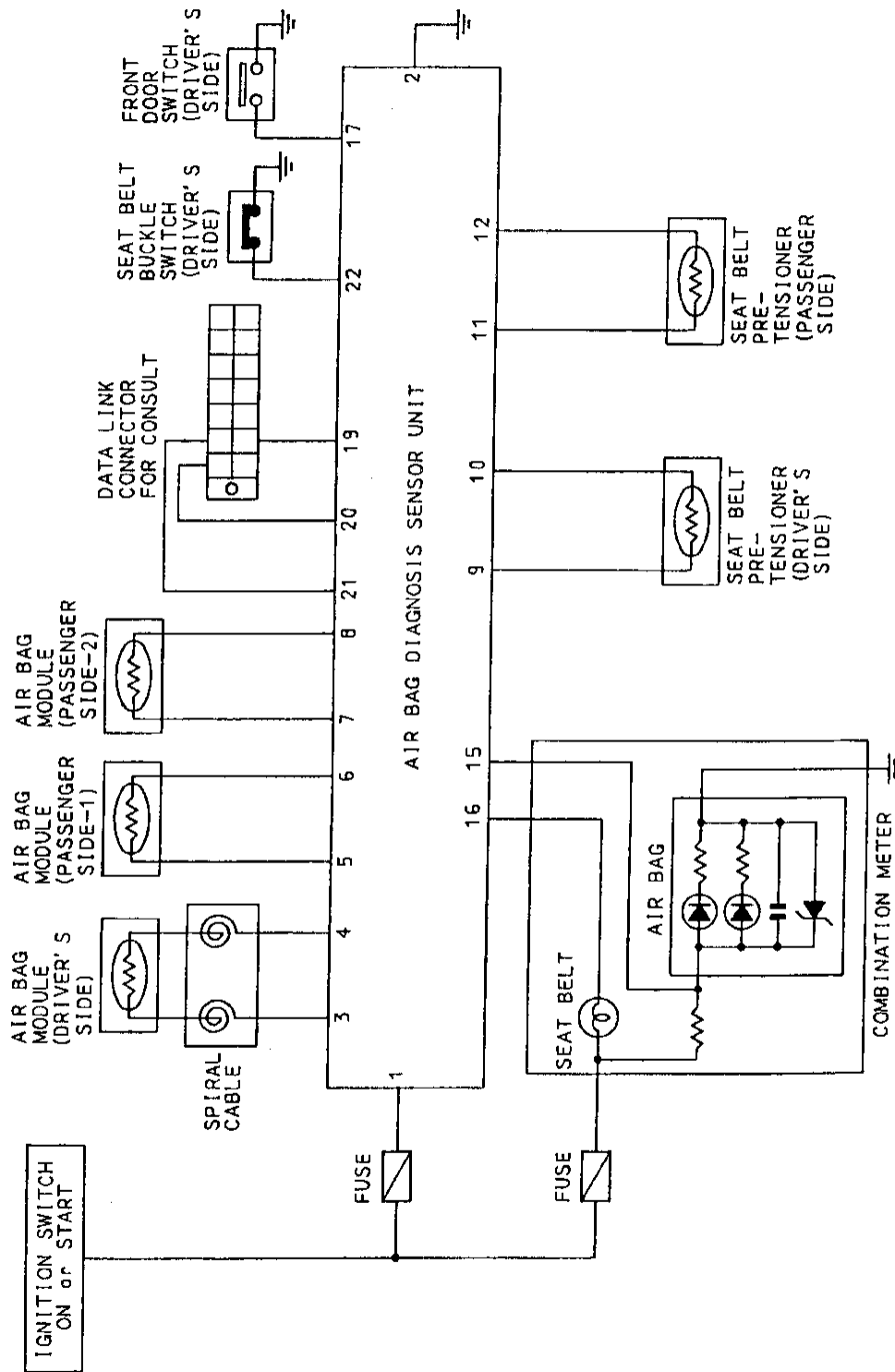

GI  
MA  
EM  
LC  
EC  
FE  
AT  
PD  
FA  
RA  
BR  
ST  
**RS**  
BT  
HA  
EL  
IDX

Wiring Diagram — SRS —

RS-SRS-01

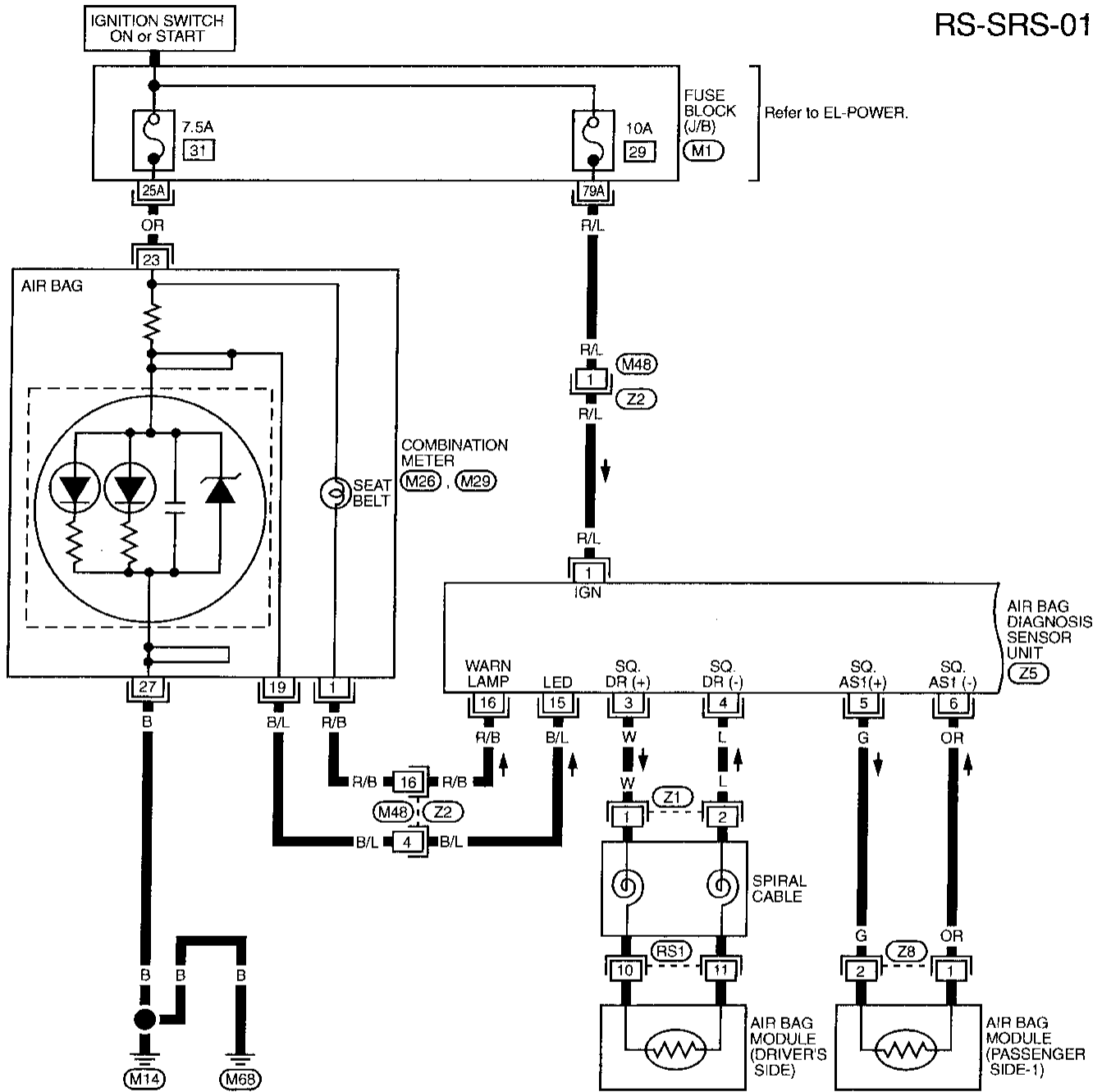

Refer to last page (Foldout page).

M1

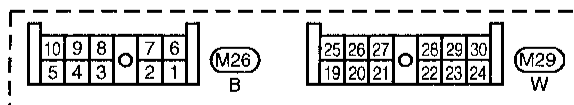
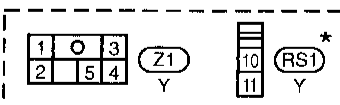
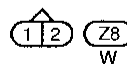
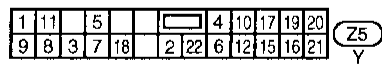
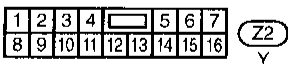

\* : This connector is not shown in "HARNESS LAYOUT" EL section.

# TROUBLE DIAGNOSES — Supplemental Restraint System (SRS)

## Wiring Diagram — SRS — (Cont'd)

RS-SRS-02

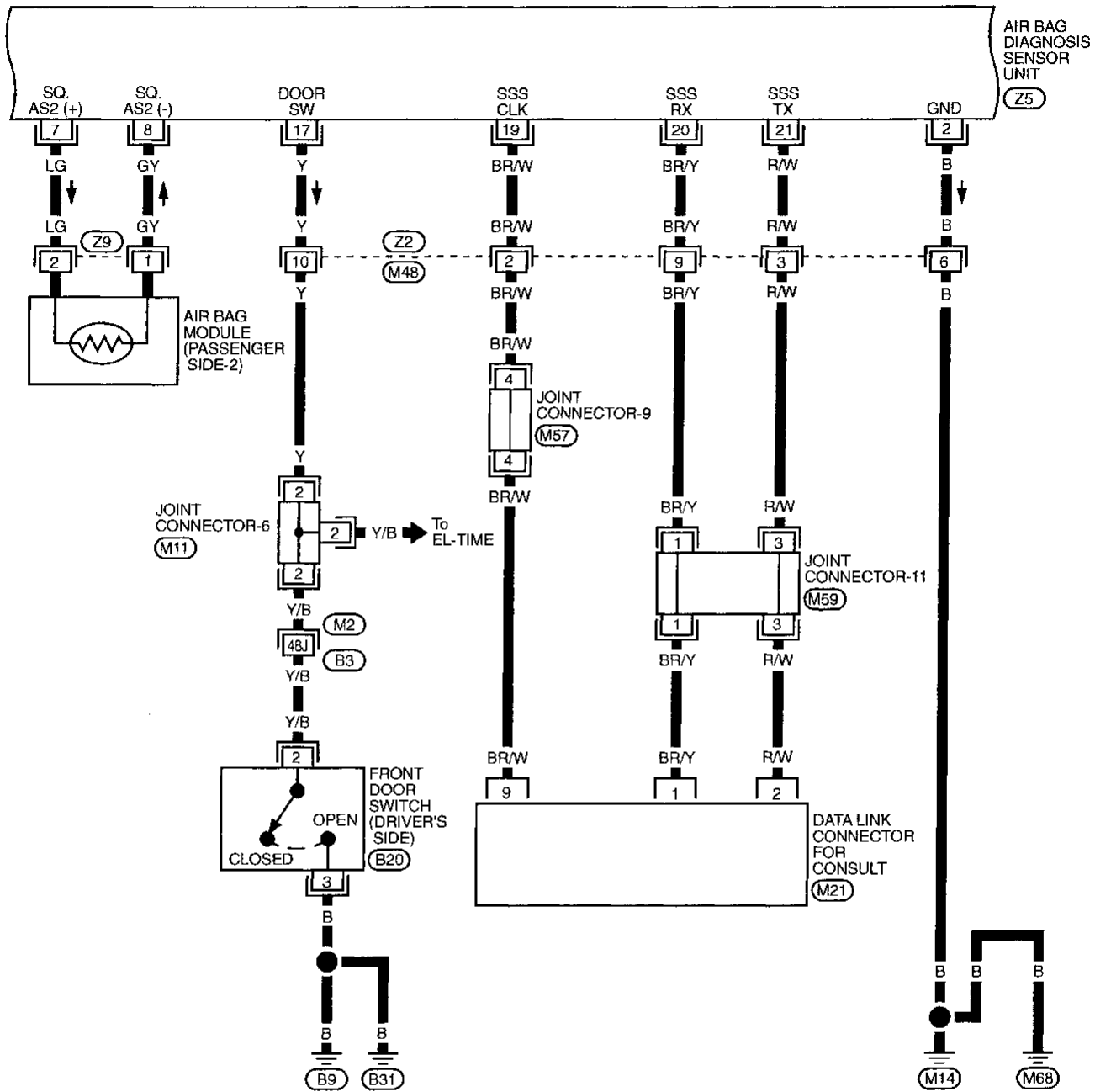

GI  
 MA  
 EM  
 LC  
 EC  
 FE  
 AT  
 PD  
 FA  
 RA  
 BR  
 ST  
**RS**  
 BT

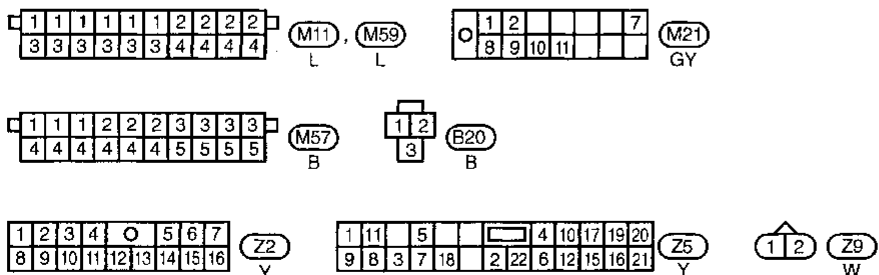

Refer to last page (Foldout page).  
 (M2), (B3)

HA  
 EL  
 IDX

# TROUBLE DIAGNOSES — Supplemental Restraint System (SRS)

## Wiring Diagram — SRS — (Cont'd)

RS-SRS-03

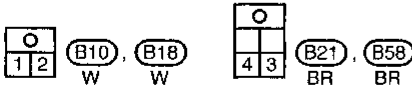
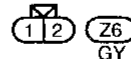
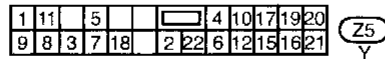
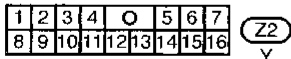
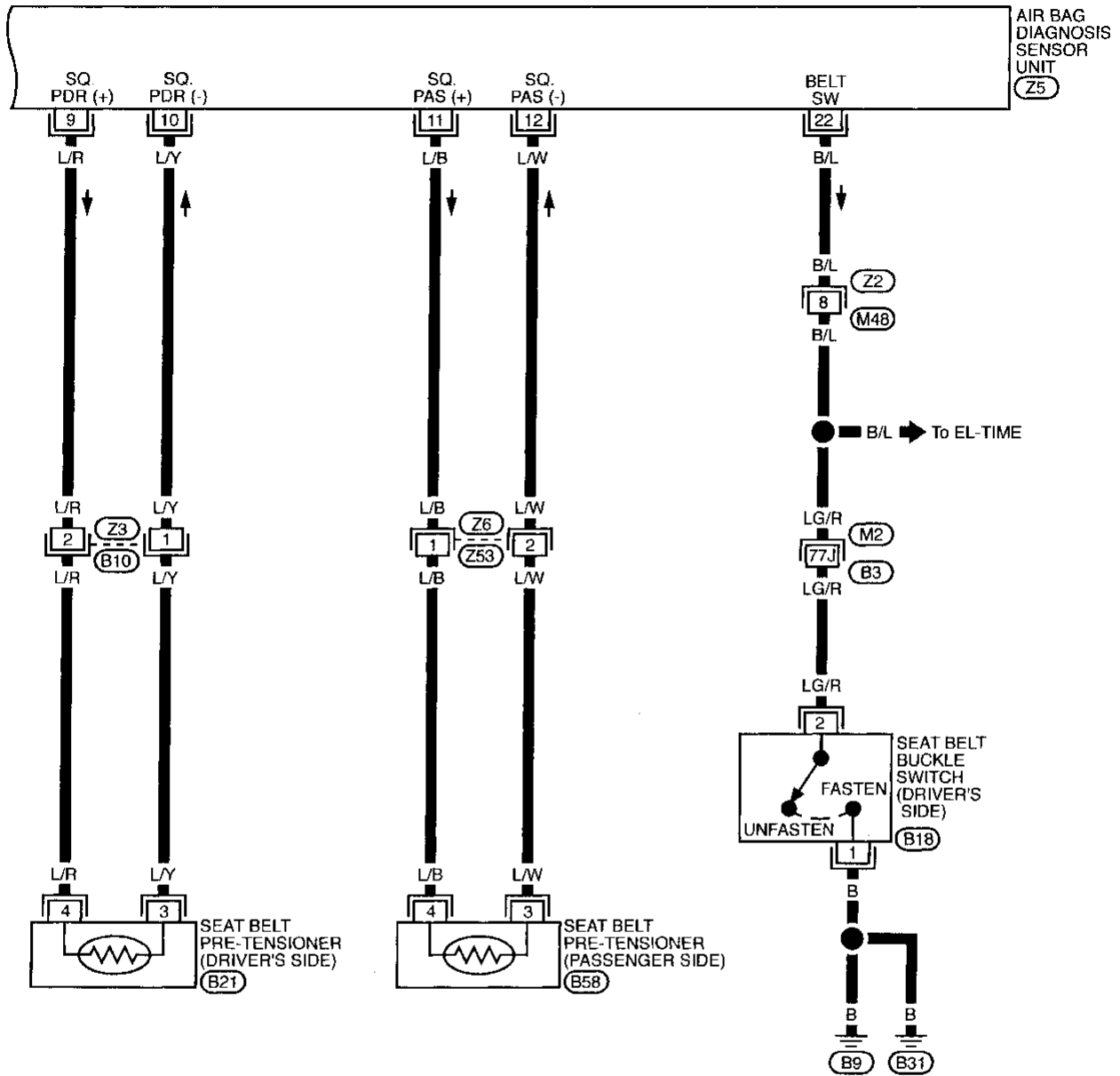

Refer to last page (Foldout page).

M2, B3



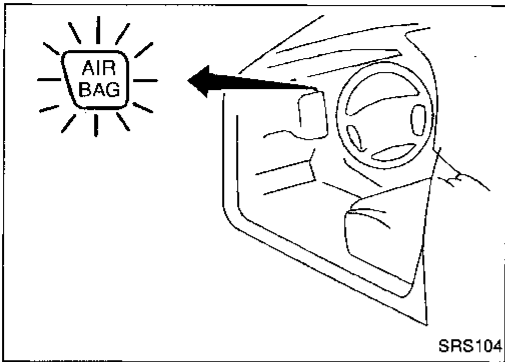



## Self-diagnosis

### DIAGNOSTIC PROCEDURE 1 ( without CONSULT)

Checking air bag system operation by using "AIR BAG" warning lamp — User mode

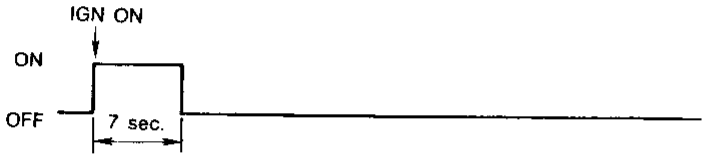
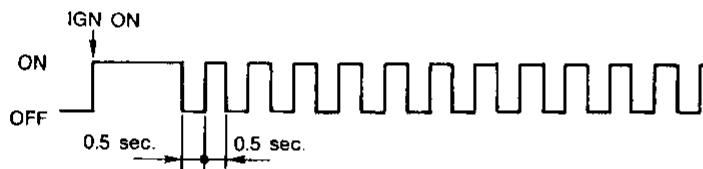
1. After turning ignition switch from "OFF" to "ON", "AIR BAG" warning lamp operates.
2. Compare "AIR BAG" warning lamp operation to the chart below.

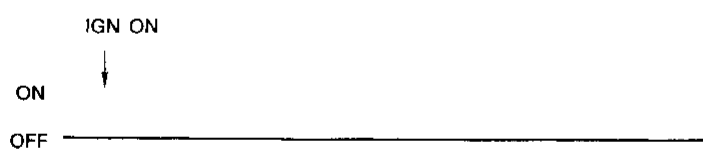
"AIR BAG" warning lamp operation — User mode —	SRS condition	Reference item
 <p style="text-align: right;">MRS095A</p>	No malfunction is detected. No further action is necessary.	—
 <p style="text-align: right;">MRS096A</p>	The system has problem and needs to be repaired as indicated.	Go to DIAGNOSTIC PROCEDURE 2, or 3 (RS-27 or 28).
 <p style="text-align: right;">MRS097A</p>	Air bag is deployed.  Diagnosis sensor unit fuse or circuit is faulty and needs to be repaired.	Go to COLLISION DIAGNOSIS (RS-43).  Go to DIAGNOSTIC PROCEDURE 8 (RS-39).
 <p style="text-align: right;">MRS098A</p>	Diagnosis sensor unit or "AIR BAG" warning lamp circuit is shorted or open and needs to be repaired.	Go to DIAGNOSTIC PROCEDURE 9 (RS-39).

#### NOTE:

If "AIR BAG" warning lamp operates differently from the operations shown above, refer to "AIR BAG" warning lamp operation — Diagnosis mode —, DIAGNOSTIC PROCEDURE 5, RS-31. Then repair as necessary.

# TROUBLE DIAGNOSES — Supplemental Restraint System (SRS)

## Self-diagnosis (Cont'd)

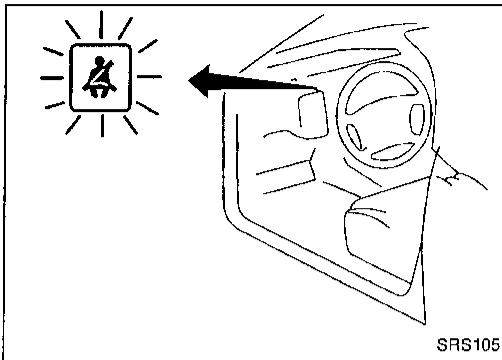

### Checking seat belt pre-tensioner operation by using "SEAT BELT" warning lamp — User mode

1. After turning ignition switch from "OFF" to "ON", "SEAT BELT" warning lamp operates.
2. Compare "SEAT BELT" warning lamp operation to the chart below.

"SEAT BELT" warning lamp operation	SRS condition	Reference item
<p>● After seat belt has been fastened.</p> <p>MRS095A</p>	No malfunction is detected. No further action is necessary.	
<p>● When seat belt has not been fastened.</p> <p>SRS086</p>		
<p>● After seat belt has been fastened.</p> <p>MRS096A</p>	<ul style="list-style-type: none"> <li>● Seat belt pre-tensioner circuit is opened, or</li> <li>● Seat belt pre-tensioner power supply or ground circuit is shorted.</li> </ul>	<ol style="list-style-type: none"> <li>1. Visually check the wiring harness connections.</li> <li>2. Replace driver's and front passenger seat belt assemblies. (Before disposing, they must be deactivated.)</li> <li>3. Replace diagnosis sensor unit.</li> <li>4. Replace air bag harness.</li> </ol>
<p>● When seat belt has not been fastened.</p> <p>SRS087</p>		
<p>MRS097A</p>	Seat belt pre-tensioner is deployed.	Go to COLLISION DIAGNOSIS (RS-44).
<p>MRS098A</p>	Diagnosis sensor unit is malfunctioning and needs to be repaired.	Go to DIAGNOSTIC PROCEDURE 11 (RS-42).
<p>MRS098A</p>	Diagnosis sensor unit or "SEAT BELT" warning lamp circuit is shorted or open and needs to be repaired.	Go to DIAGNOSTIC PROCEDURE 12 (RS-43).

# TROUBLE DIAGNOSES — Supplemental Restraint System (SRS)

## Self-diagnosis (Cont'd)

### DIAGNOSTIC PROCEDURE 2 (CONSULT with CONSULT)

Inspecting SRS malfunctioning parts by using CONSULT —  
Diagnosis mode

1. Turn ignition switch "OFF".
2. Connect "CONSULT" to Data link connector.

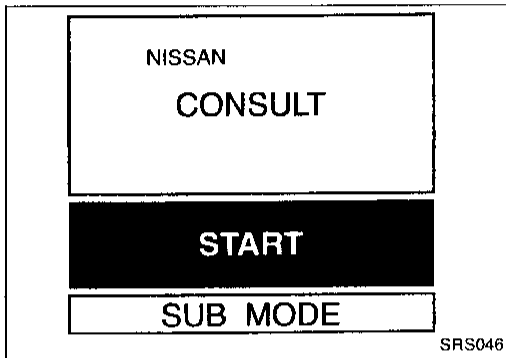
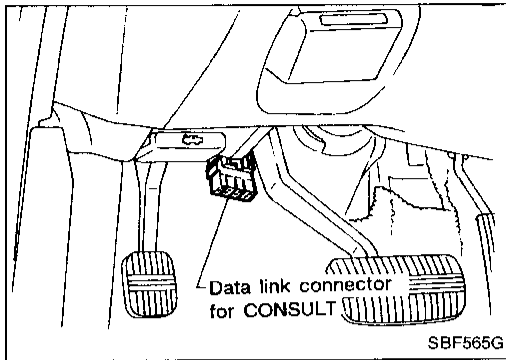

3. Turn ignition switch "ON".
4. Touch "START".

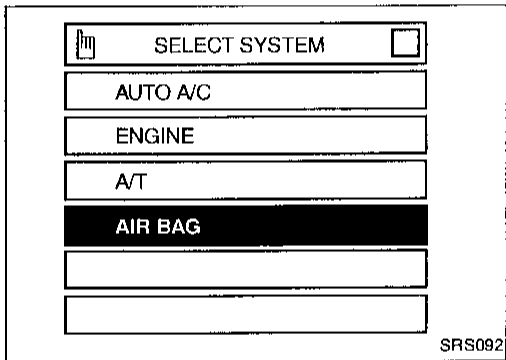

5. Touch "AIR BAG".

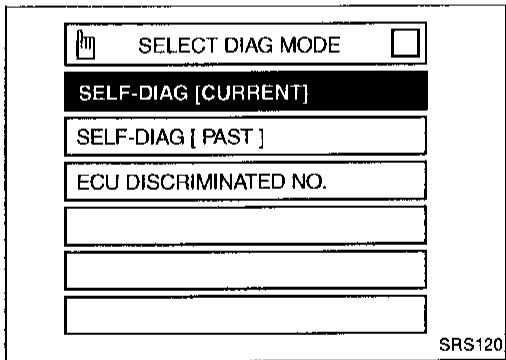

6. Touch "SELF-DIAG [CURRENT]".

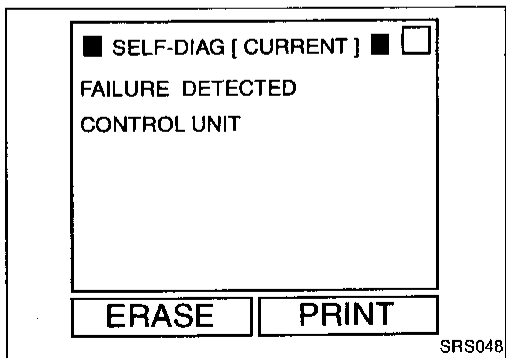

7. Diagnostic codes are displayed on "SELF-DIAG [CURRENT]".

GI

MA

EM

LC

EC

FE

AT

PD

FA

RA

BR

ST

RS

BT

HA

EL

IDX

## TROUBLE DIAGNOSES — Supplemental Restraint System (SRS)

### Self-diagnosis (Cont'd)

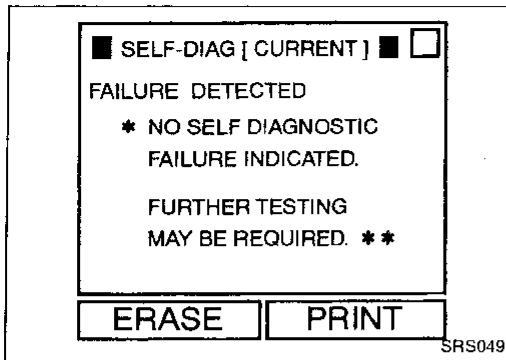

If no self-diagnostic failure is detected on "SELF-DIAG [CURRENT]", go to DIAGNOSTIC PROCEDURE 6, page RS-33.

8. Touch "PRINT".
9. Compare diagnostic codes to the CONSULT DIAGNOSTIC CODE CHART, page RS-36.
10. Touch "BACK" key of CONSULT until SELECT SYSTEM appears, then turn off CONSULT.
11. Turn ignition switch "OFF", then disconnect CONSULT and both battery cables.
12. Repair the system as outlined by the "Repair order" in CONSULT DIAGNOSTIC CODE CHART, that corresponds to the problem code. For replacement procedure of component parts, refer to RS-8.
13. After repairing the system, go to DIAGNOSTIC PROCEDURE 4, page RS-29.

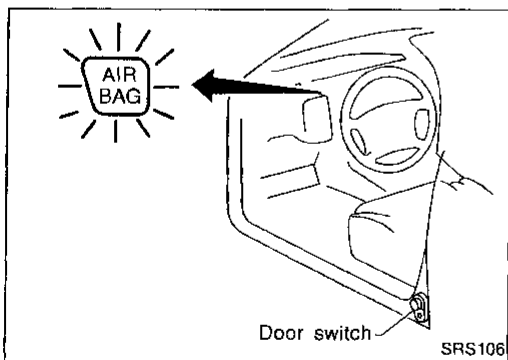

### DIAGNOSTIC PROCEDURE 3 (⊗ without CONSULT)

Inspecting SRS malfunctioning parts by using "AIR BAG" warning lamp — Diagnosis mode

1. Open driver's door.
2. Turn ignition switch from "OFF" to "ON".
3. Press driver's door switch at least 5 times within 7 seconds after turning ignition switch "ON".  
SRS is now in Diagnosis mode.
4. "AIR BAG" warning lamp operates in Diagnosis mode as follows:

#### NOTE:

If SRS does not enter diagnostic mode, go to DIAGNOSTIC PROCEDURE 10, page RS-41.

# TROUBLE DIAGNOSES — Supplemental Restraint System (SRS)

## Self-diagnosis (Cont'd)

No.	"AIR BAG" warning lamp operation — Diagnosis mode —	SRS condition
1	<div style="text-align: right;">(a) through (b) are repeated.</div> <p style="text-align: right;">MRS100A</p>	<p>Intermittent problem has been detected in the past. Go to DIAGNOSTIC PROCEDURE 7 (RS-33).</p>
2	<div style="text-align: right;">(a) through (d) are repeated.</div> <p>NOTE:            (a) — Interval I            (b) — Start signal (Start signal identifies display modes)            (c) — Interval II            (d) — Indicates malfunctioning part (0.5 sec. ON and 0.5 sec. OFF is counted as one flash.)</p> <p style="text-align: right;">MRS099A</p>	<p>The system has problem and needs to be repaired.</p>

5. Malfunctioning part is indicated by the number of flashes (part (d)). Compare the number of flashes to WARNING LAMP FLASH CODE CHART, page RS-37, and locate malfunctioning part.
6. Turn ignition switch "OFF", and disconnect both battery cables.
7. Repair the system as outlined by the "Repair order" in WARNING LAMP FLASH CODE CHART that corresponds to the flash code. For replacement procedure of component parts, refer to RS-8.
8. After repairing the system, go to DIAGNOSTIC PROCEDURE 5, page RS-31.

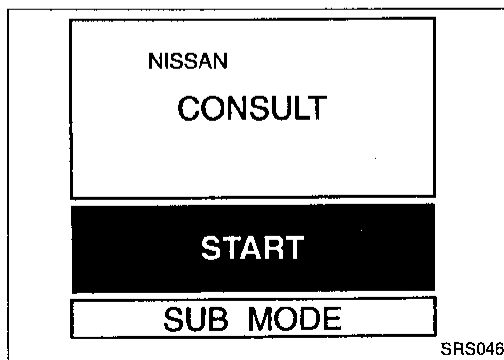
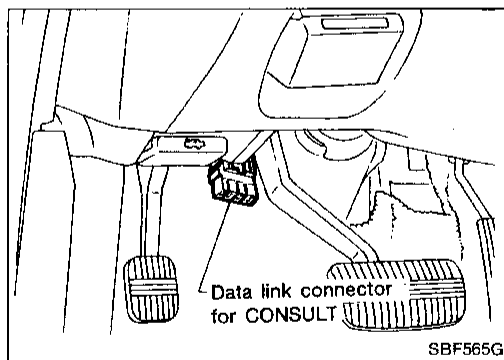

### DIAGNOSTIC PROCEDURE 4 (CONSULT with CONSULT)

#### Final checking after repairing SRS by using CONSULT — Diagnosis mode

1. After repairing SRS, connect both battery cables.
2. Connect CONSULT to Data link connector.
3. Turn ignition switch from "OFF" to "ON".
4. Touch "START".

## Self-diagnosis (Cont'd)

SELECT SYSTEM

AUTO A/C

ENGINE

A/T

**AIR BAG**

SRS092

5. Touch "AIR BAG".

SELECT DIAG MODE

**SELF-DIAG [CURRENT]**

SELF-DIAG [ PAST ]

ECU DISCRIMINATED NO.

SRS120

6. Touch "SELF-DIAG [CURRENT]".

SELF-DIAG [ CURRENT ]

FAILURE DETECTED

\* NO SELF DIAGNOSTIC FAILURE INDICATED.

FURTHER TESTING MAY BE REQUIRED. \*\*

ERASE PRINT

SRS049

7. If no malfunction is detected on "SELF-DIAG [CURRENT]", repair of SRS is completed. Touch "ERASE".

**NOTE:**

Touch "ERASE" to erase problem (Trouble code) retained in memory. Otherwise, CONSULT still senses problem in memory when step 13 (Air bag warning lamp operation check) is performed. The result is confusing a new with an old problem.

SELF-DIAG [ CURRENT ]

FAILURE DETECTED

CONTROL UNIT

ERASE PRINT

SRS048

If any problem code was displayed on "SELF-DIAG [CURRENT]", the malfunctioning part is not repaired completely or another malfunctioning part is detected. Go to DIAGNOSTIC PROCEDURE 2, page RS-27, and repair malfunctioning part completely.

8. Touch "BACK" key of CONSULT.

SELECT DIAG MODE

SELF-DIAG [CURRENT]

**SELF-DIAG [ PAST ]**

ECU DISCRIMINATED NO.

SRS121

9. Touch "SELF-DIAG [PAST]".

# TROUBLE DIAGNOSES — Supplemental Restraint System (SRS)

## Self-diagnosis (Cont'd)

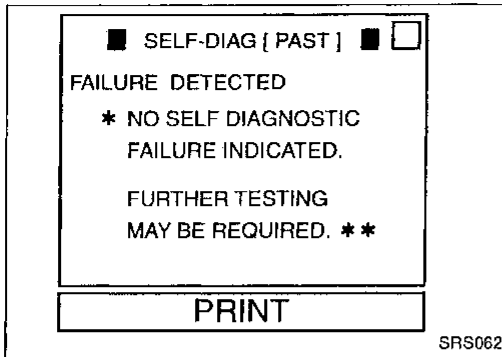

10. Check that no self-diagnostic failure is detected on "SELF-DIAG [PAST]".

11. Touch "BACK" key of CONSULT until SELECT SYSTEM appears, turn off CONSULT, then disconnect CONSULT.

12. Turn ignition switch "OFF".

13. Go to DIAGNOSTIC PROCEDURE 1, page RS-25 to check SRS operation by using "AIR BAG" and/or "SEAT BELT" warning lamp(s) in User mode.

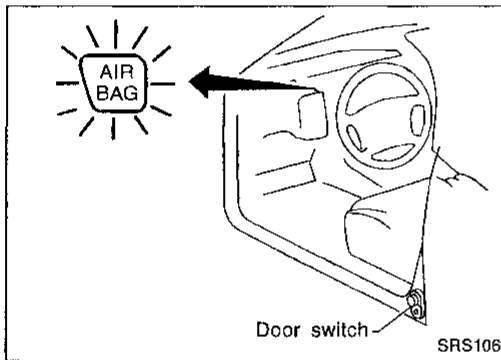

### DIAGNOSTIC PROCEDURE 5 (⌚ without CONSULT)

Final checking after repairing SRS by using "AIR BAG" warning lamp — Diagnosis mode and User mode

1. After repairing SRS connect both battery cables.
2. Open driver's door.
3. Turn ignition switch from "OFF" to "ON".
4. "AIR BAG" warning lamp operates in diagnostic mode as follows:

No.	"AIR BAG" warning lamp operation — Diagnosis mode —	SRS condition
1	<p>IGN ON</p> <p>ON</p> <p>OFF</p> <p>7 sec.</p> <p>3 sec.</p> <p>2 sec.</p> <p>MRS100A</p> <p>(a) through (b) are repeated.</p>	No malfunction is detected or repair is completed. No further action is necessary.
2	<p>IGN ON</p> <p>ON</p> <p>OFF</p> <p>7 sec.</p> <p>3 sec.</p> <p>2 sec.</p> <p>2 sec. Varies with malfunctioning part</p> <p>0.5 sec.</p> <p>0.5 sec.</p> <p>MRS099A</p> <p>(a) through (d) are repeated.</p> <p>NOTE:</p> <p>(a) — Interval I</p> <p>(b) — Start signal (Start signal identifies display modes)</p> <p>(c) — Interval II</p> <p>(d) — Indicates malfunctioning part (0.5 sec. ON and 0.5 sec. OFF is counted as one flash.)</p>	The system has problem and needs to be repaired.

# TROUBLE DIAGNOSES — Supplemental Restraint System (SRS)

## Self-diagnosis (Cont'd)

- If "AIR BAG" warning lamp operates as shown in No. 1 in the chart above, press driver's door switch at least 5 times within 7 seconds after turning ignition switch "ON". SRS is now in User mode.

If "AIR BAG" warning lamp operates as in No. 2 in chart above, the malfunctioning part is not repaired completely, or another malfunctioning part is detected. Go to DIAGNOSTIC PROCEDURE 3, page RS-28, and repair malfunctioning part completely.

- Turn ignition switch "ON". "AIR BAG" warning lamp operates in User mode. Compare "AIR BAG" warning lamp operation to the chart below.

"AIR BAG" warning lamp operation — User mode —	SRS condition	Reference item
<p>MRS095A</p>	<p>No malfunction is detected. No further action is necessary.</p>	—
<p>MRS096A</p>	<p>The system has problem and needs to be repaired as indicated.</p>	Go to DIAGNOSTIC PROCEDURE 2 or 3 (RS-27 or 28).
<p>MRS097A</p>	<p>Air bag is deployed.  Diagnosis sensor unit fuse or circuit is faulty and needs to be repaired.</p>	<p>Go to COLLISION DIAGNOSIS (RS-43).  Go to DIAGNOSTIC PROCEDURE 8 (RS-39).</p>
<p>MRS098A</p>	<p>Diagnosis sensor unit or "AIR BAG" warning lamp circuit is shorted or open and needs to be repaired.</p>	Go to DIAGNOSTIC PROCEDURE 9 (RS-39).



**Self-diagnosis (Cont'd)**

**DIAGNOSTIC PROCEDURE 6 (Continued from DIAGNOSTIC PROCEDURE 2)**

**Inspecting SRS malfunctioning record**

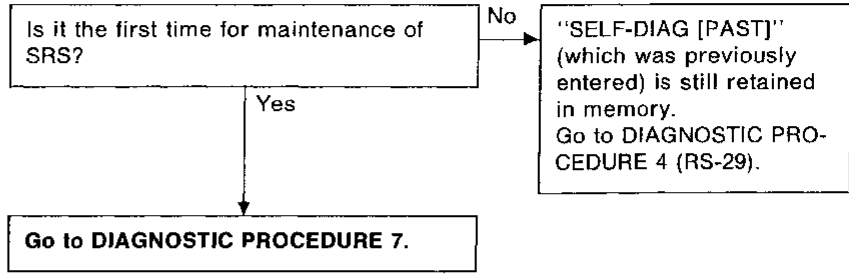

GI  
MA  
EM  
LC  
EC  
FE  
AT

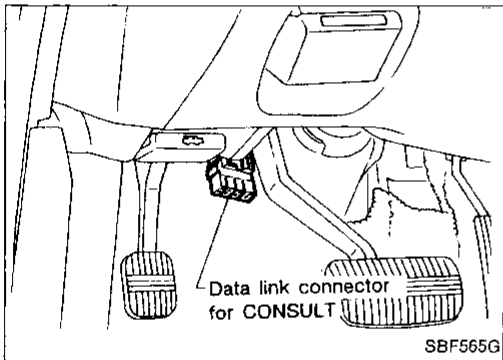

**DIAGNOSTIC PROCEDURE 7 (CONSULT with CONSULT)**

**Inspecting SRS intermittent problem by using CONSULT — Diagnosis mode**

1. Turn ignition switch "OFF".
2. Connect "CONSULT" to Data link connector.

PD  
EA  
RA  
BR  
ST

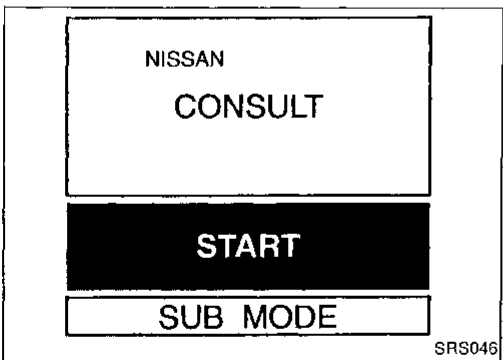

3. Turn ignition switch "ON".
4. Touch "START".

RS  
BT  
HA

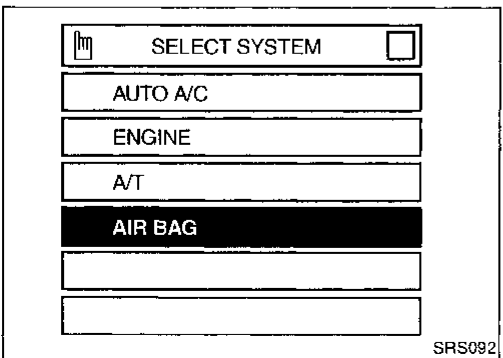

5. Touch "AIR BAG".

EL  
IDX

## Self-diagnosis (Cont'd)

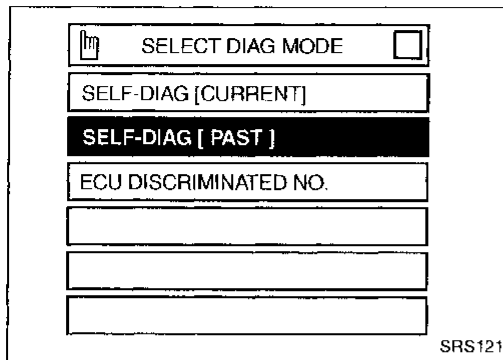

6. Touch "SELF-DIAG [PAST]".

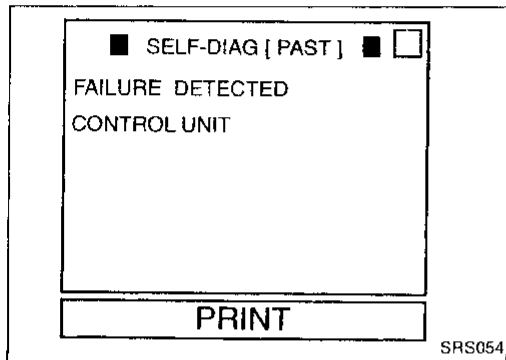

7. Diagnostic codes are displayed on "SELF-DIAG [PAST]".

**NOTE: Past malfunction for seat belt pre-tensioner will not be displayed on "SELF-DIAG [PAST]".**

8. Touch "PRINT".
9. Compare diagnostic codes to the INTERMITTENT PROBLEM DIAGNOSTIC CODE CHART, page RS-38.
10. Touch "BACK" key of CONSULT until SELECT SYSTEM appears, then turn off CONSULT.
11. Turn ignition switch "OFF", then disconnect CONSULT and both battery cables.
12. Repair the system as outlined by the "Repair order" in INTERMITTENT PROBLEM DIAGNOSTIC CODE CHART, that corresponds to the problem code. For replacement procedure of component parts, refer to RS-8.
13. Go to DIAGNOSTIC PROCEDURE 1, page RS-25 to check SRS operation by using "AIR BAG" and/or "SEAT BELT" warning lamp(s) in User mode.

# TROUBLE DIAGNOSES — Supplemental Restraint System (SRS)

## Self-diagnosis (Cont'd)

### CONSULT DIAGNOSTIC CODE CHART

Diagnostic item	Explanation	Repair order Recheck SRS at each replacement.	
NO SELF DIAGNOSTIC FAILURE INDICATED.	Normal. The SRS system is in good order.	—	GI
AIRBAG MODULE [OPEN]	The circuit for driver's air bag module is open. (including the spiral cable)	<ol style="list-style-type: none"> <li>1. Visually check the wiring harness connections.</li> <li>2. Replace the spiral cable.</li> <li>3. Replace driver's air bag module. (Before disposing of it, it must be deployed.)</li> <li>4. Replace the diagnosis sensor unit.</li> <li>5. Replace the air bag harness.</li> </ol>	MA
AIRBAG MODULE [VB-SHORT]	The circuit for driver's air bag module is shorted to some power supply circuit. (including the spiral cable)		EM
AIRBAG MODULE [GND-SHORT]	The circuit for driver's air bag module is shorted to ground. (including the spiral cable)		LC
AIRBAG MODULE [SHORT]	The circuits for driver's air bag module are shorted to each other.		EC
ASSIST A/B MODULE 1 [OPEN]	The circuit for front passenger air bag module 1 is open.		<ol style="list-style-type: none"> <li>1. Visually check the wiring harness connections.</li> <li>2. Replace front passenger air bag module. (Before disposing of it, it must be deployed.)</li> <li>3. Replace the diagnosis sensor unit.</li> <li>4. Replace the air bag harness.</li> </ol>
ASSIST A/B MODULE 1 [VB-SHORT]	The circuit for front passenger air bag module 1 is shorted to some power supply circuit.	AT	
ASSIST A/B MODULE 1 [GND-SHORT]	The circuit for front passenger air bag module 1 is shorted to ground.	PD	
ASSIST A/B MODULE 1 [SHORT]	The circuits for front passenger air bag module 1 are shorted to each other.	FA	
ASSIST A/B MODULE 2 [OPEN]	The circuit for front passenger air bag module 2 is open.	<ol style="list-style-type: none"> <li>1. Visually check the wiring harness connections.</li> <li>2. Replace front passenger air bag module. (Before disposing of it, it must be deployed.)</li> <li>3. Replace the diagnosis sensor unit.</li> <li>4. Replace the air bag harness.</li> </ol>	RA
ASSIST A/B MODULE 2 [VB-SHORT]	The circuit for front passenger air bag module 2 is shorted to some power supply circuit.		BR
ASSIST A/B MODULE 2 [GND-SHORT]	The circuit for front passenger air bag module 2 is shorted to ground.		ST
ASSIST A/B MODULE 2 [SHORT]	The circuits for front passenger air bag module 2 are shorted to each other.		RS
DRIVE PRE-TENSION [OPEN/VB-SHORT]	The circuit for the driver's pre-tensioner is open or shorted to some power supply circuit.	<ol style="list-style-type: none"> <li>1. Visually check the wiring harness connections.</li> <li>2. Replace the driver's seat belt. (Before disposing, it must be deactivated.)</li> <li>3. Replace the diagnosis sensor unit.</li> <li>4. Replace the air bag harness.</li> </ol>	BT
DRIVE PRE-TENSION [GND-SHORT]	The circuit for the driver's pre-tensioner is shorted to ground.		HA
ASSIST PRE-TENSION [OPEN/VB-SHORT]	The circuit for the front passenger pre-tensioner is open or shorted to some power supply circuit.	<ol style="list-style-type: none"> <li>1. Visually check the wiring harness connections.</li> <li>2. Replace the front passenger seat belt. (Before disposing, it must be deactivated.)</li> <li>3. Replace the diagnosis sensor unit.</li> <li>4. Replace the air bag harness.</li> </ol>	EL
ASSIST PRE-TENSION [GND-SHORT]	The circuit for the front passenger pre-tensioner is shorted to ground.		IDX

## TROUBLE DIAGNOSES — Supplemental Restraint System (SRS)

### Self-diagnosis (Cont'd)

Diagnostic item	Explanation	Repair order Recheck SRS at each replacement.
CONTROL UNIT	The diagnosis sensor unit is out of order.	<ol style="list-style-type: none"> <li>1. Visually check the wiring harness connections.</li> <li>2. Replace the diagnosis sensor unit.</li> <li>3. Replace the air bag harness.</li> <li>4. Replace the main harness.</li> </ol>
CONTROL UNIT [33]		<ul style="list-style-type: none"> <li>● Replace the diagnosis sensor unit.</li> </ul>
CONTROL UNIT [C6]		
CONTROL UNIT [D4]		
CONTROL UNIT [D7]		
CONTROL UNIT [C1]	Low battery voltage (Less than 9V)	<ul style="list-style-type: none"> <li>● Go to DIAGNOSTIC PROCEDURE 4 (RS-29) after charging battery. (Do not replace the diagnosis sensor unit.)</li> </ul>
	The diagnosis sensor unit is out of order.	<ul style="list-style-type: none"> <li>● Replace the diagnosis sensor unit.</li> </ul>

\* Follow the procedures in numerical order when repairing malfunctioning parts. Confirm whether malfunction is eliminated using the air bag warning lamp (in user mode) or CONSULT each time repair is finished. If malfunction is still observed, proceed to the next step. When malfunction is eliminated, further repair work is not required.

# TROUBLE DIAGNOSES — Supplemental Restraint System (SRS)

## Self-diagnosis (Cont'd)

### WARNING LAMP FLASH CODE CHART

Warning lamp	Flash code ① (# of flashes)	Explanation	Repair order Recheck SRS at each replacement.	
"AIR BAG" warning lamp	0	No malfunction is detected.	—	GI
	2	The driver's air bag module circuit is out of order.	1. Visually check the wiring harness connections. 2. Replace the spiral cable. 3. Replace the driver's air bag module. (Before disposing of it, it must be deployed.) 4. Replace the diagnosis sensor unit. 5. Replace the air bag harness.	MA EM
	7	The diagnosis sensor unit is out of order.	1. Visually check the wiring harness connections. 2. Replace the diagnosis sensor unit. 3. Replace the air bag harness. 4. Replace the main harness.	LC EC
	8	The front passenger air bag module circuit is out of order.	1. Visually check the wiring harness connections. 2. Replace the front passenger air bag module. (Before disposing of it, it must be deployed.) 3. Replace the diagnosis sensor unit. 4. Replace the air bag harness.	FE AT

\* Follow the procedures in numerical order when repairing malfunctioning parts. Confirm whether malfunction is eliminated using the air bag warning lamp (in user mode) or CONSULT each time repair is finished. If malfunction is still observed, proceed to the next step. When malfunction is eliminated, further repair work is not required.

PD

FA

RA

BR

ST

**RS**

BT

HA

EL

IDX

## TROUBLE DIAGNOSES — Supplemental Restraint System (SRS)

### Self-diagnosis (Cont'd)

#### INTERMITTENT PROBLEM DIAGNOSTIC CODE CHART

Diagnostic item	Explanation	Repair order Recheck SRS at each replacement.
NO SELF DIAGNOSTIC FAILURE INDICATED.	No malfunction is detected.	—
AIRBAG MODULE [VB-SHORT]	Driver's air bag module circuit is shorted to some power supply circuit. (including the spiral cable)	<ol style="list-style-type: none"> <li>1. Visually check the wiring harness connection.</li> <li>2. Replace the harness if it has visible damage.</li> <li>3. Replace the spiral cable.</li> </ol>
AIRBAG MODULE [OPEN]	Driver's air bag module circuit is open. (including the spiral cable)	<ol style="list-style-type: none"> <li>1. Visually check the wiring harness connection.</li> <li>2. Replace the harness if it has visible damage.</li> </ol>
AIRBAG MODULE [GND-SHORT]	Driver's air bag module circuit is shorted to ground. (including the spiral cable)	<ol style="list-style-type: none"> <li>3. Replace the spiral cable.</li> <li>4. Replace driver's air bag module. (Before disposal of it, it must be deployed.)</li> </ol>
AIRBAG MODULE [SHORT]	Driver's air bag module circuits are shorted to each other.	
ASSIST A/B MODULE [VB-SHORT]	Front passenger air bag module circuit is shorted to some power supply circuit.	<ol style="list-style-type: none"> <li>1. Visually check the wiring harness connection.</li> <li>2. Replace the harness if it has visible damage.</li> <li>3. Replace the air bag harness.</li> </ol>
ASSIST A/B MODULE [OPEN]	Front passenger air bag module circuit is open.	<ol style="list-style-type: none"> <li>1. Visually check the wiring harness connection.</li> <li>2. Replace the harness if it has visible damage.</li> </ol>
ASSIST A/B MODULE [GND-SHORT]	Front passenger air bag module circuit is shorted to ground.	<ol style="list-style-type: none"> <li>3. Replace front passenger air bag module. (Before disposal of it, it must be deployed.)</li> </ol>
ASSIST A/B MODULE [SHORT]	Front passenger air bag module circuits are shorted to each other.	
CONTROL UNIT	Diagnosis sensor unit is out of order.	Replace the diagnosis sensor unit.
CONTROL UNIT [33]		
CONTROL UNIT [C6]		
CONTROL UNIT [D4]		
CONTROL UNIT [D7]		
CONTROL UNIT [C1]	Low battery voltage (Less than 9V)	Go to DIAGNOSTIC PROCEDURE 4 (RS-29) after charging battery. (Do not replace the diagnosis sensor unit.)
	The diagnosis sensor unit is out of order.	Replace the diagnosis sensor unit.

**Trouble Diagnoses for Air Bag Warning Lamp  
DIAGNOSTIC PROCEDURE 8**

**SYMPTOM: "AIR BAG" warning lamp does not turn off.**

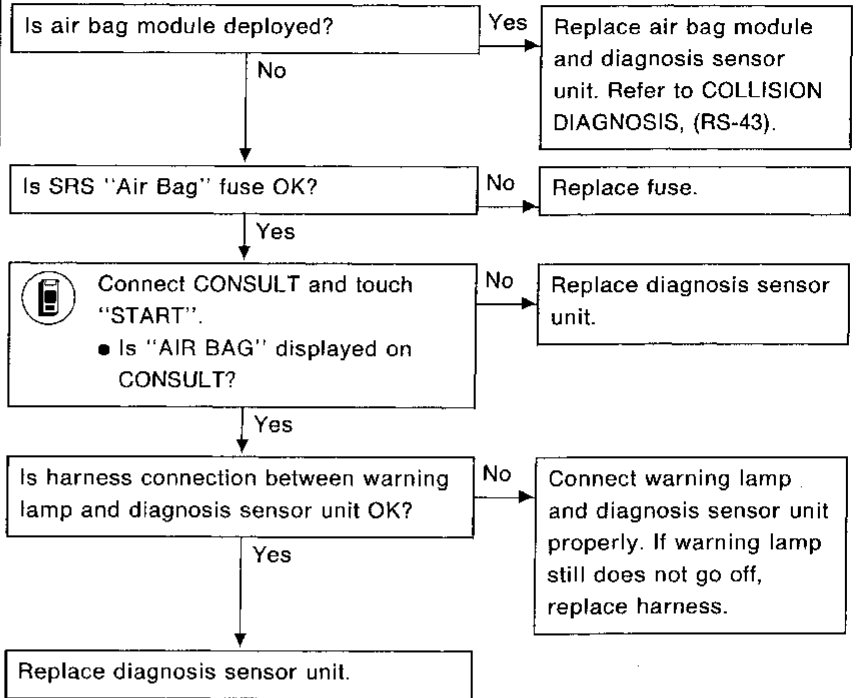
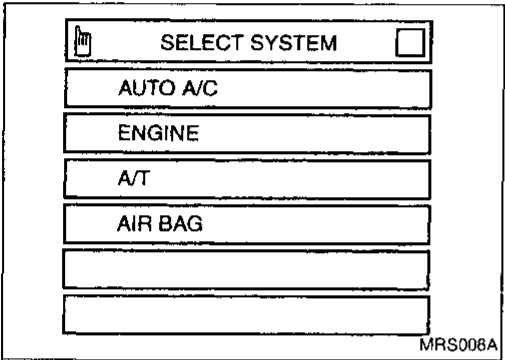
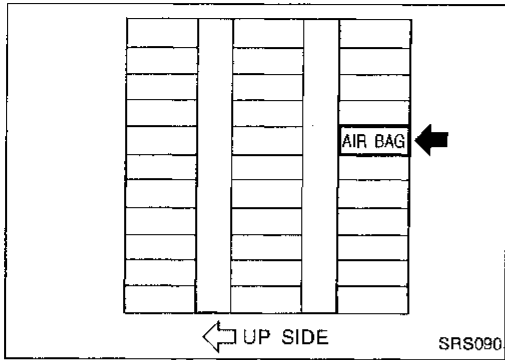

GF  
MA  
EM  
LC  
EC  
FE  
AT  
PD

**DIAGNOSTIC PROCEDURE 9**

**SYMPTOM: "AIR BAG" warning lamp does not turn on.**

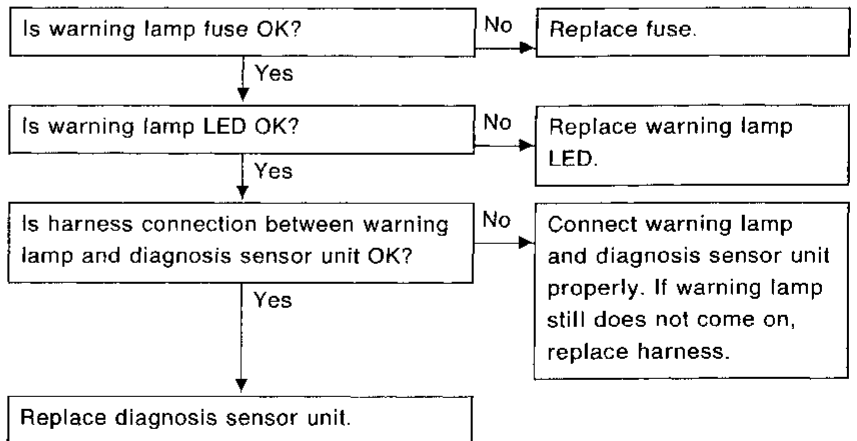
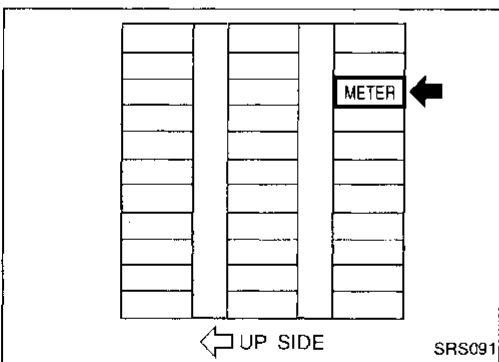

RS  
BT  
HA  
EI  
DX

# TROUBLE DIAGNOSES — Supplemental Restraint System (SRS)

## Trouble Diagnoses for Air Bag Warning Lamp

(Cont'd)

### DIAGNOSTIC PROCEDURE 10

**SYMPTOM: SRS does not enter Diagnostic mode.**

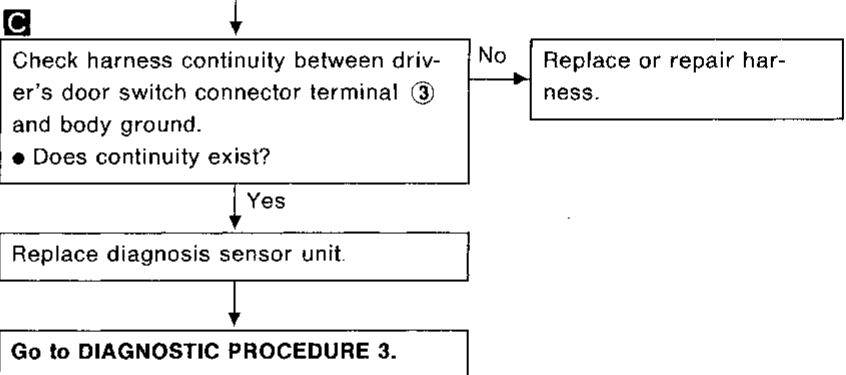
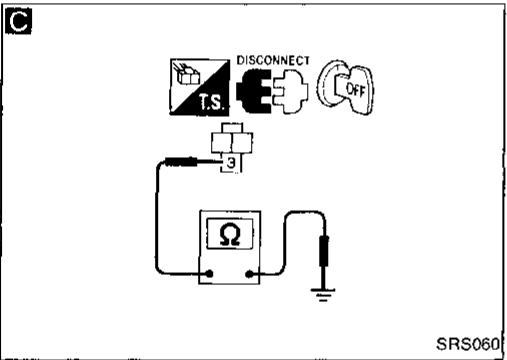
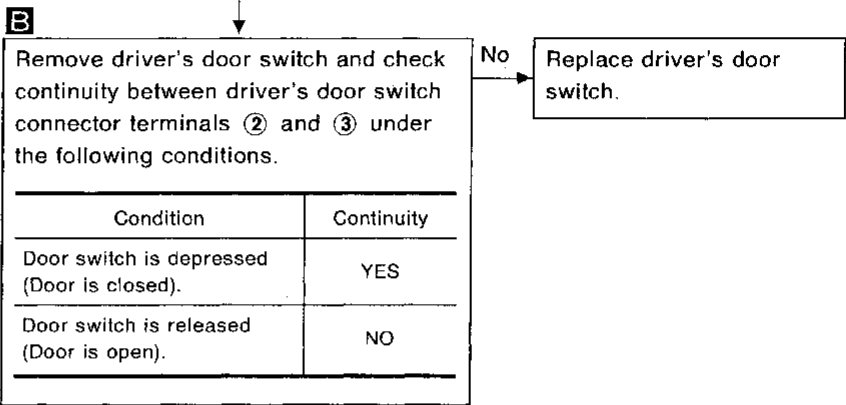
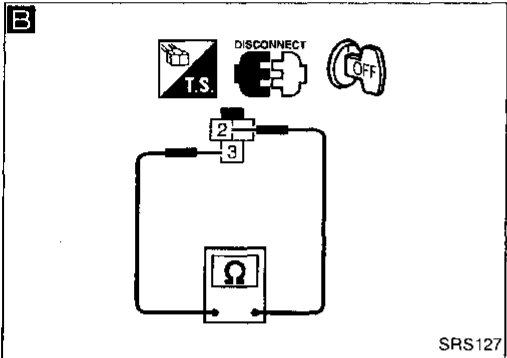
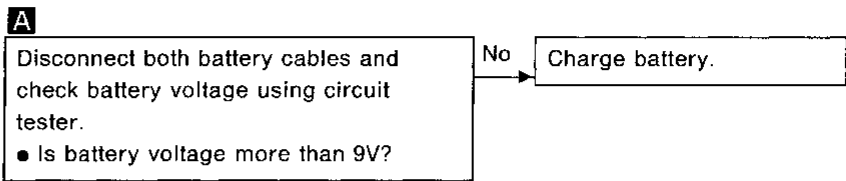
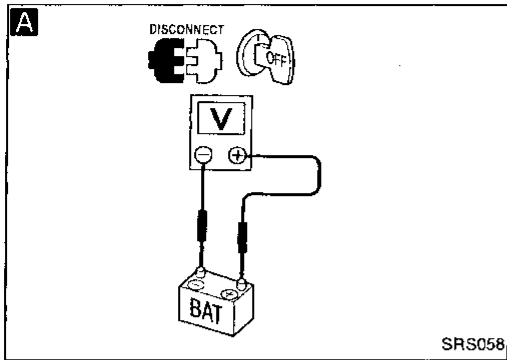



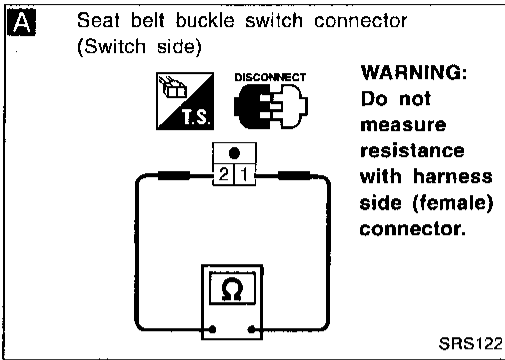

**Trouble Diagnosis for Seat Belt Pre-tensioner  
DIAGNOSTIC PROCEDURE 11**

**SYMPTOM: "SEAT BELT" warning lamp does not turn off.**

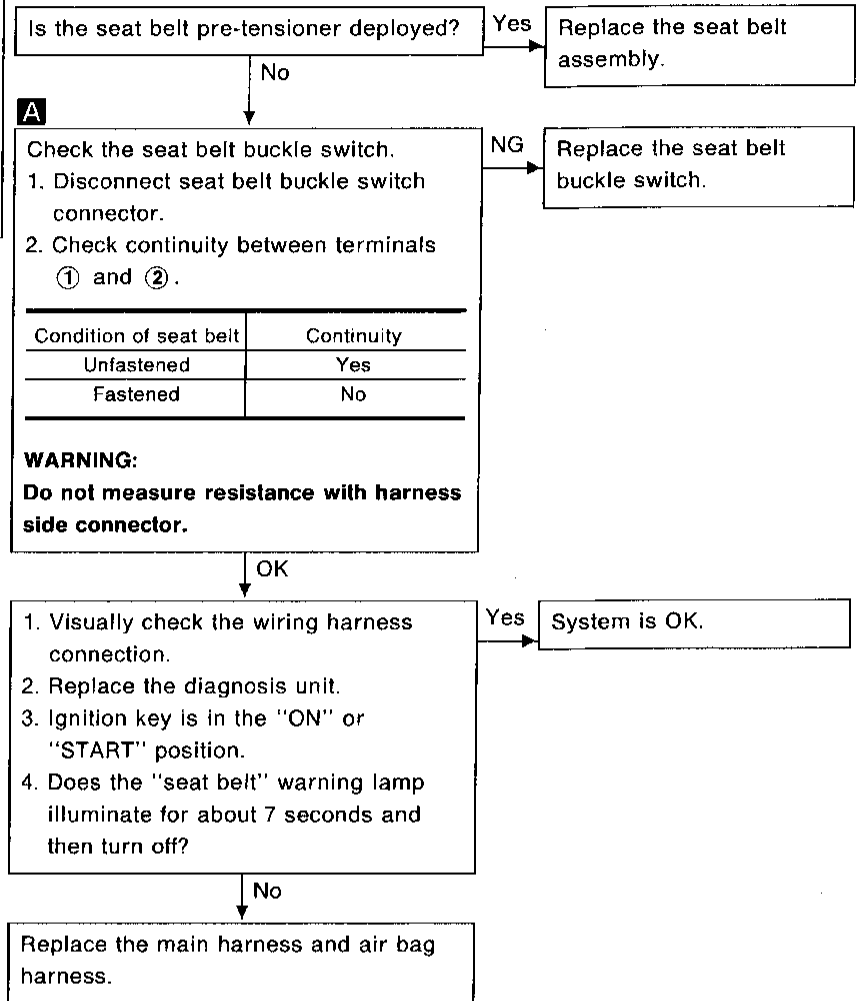

GI  
MA  
EM  
LC  
EC  
FE  
AT  
PD  
FA  
RA  
BR  
ST  
RS  
BT  
HA  
EL  
IDX

## Trouble Diagnosis for Seat Belt Pre-tensioner (Cont'd)

### DIAGNOSTIC PROCEDURE 12

**SYMPTOM: "SEAT BELT" warning lamp does not turn on.**

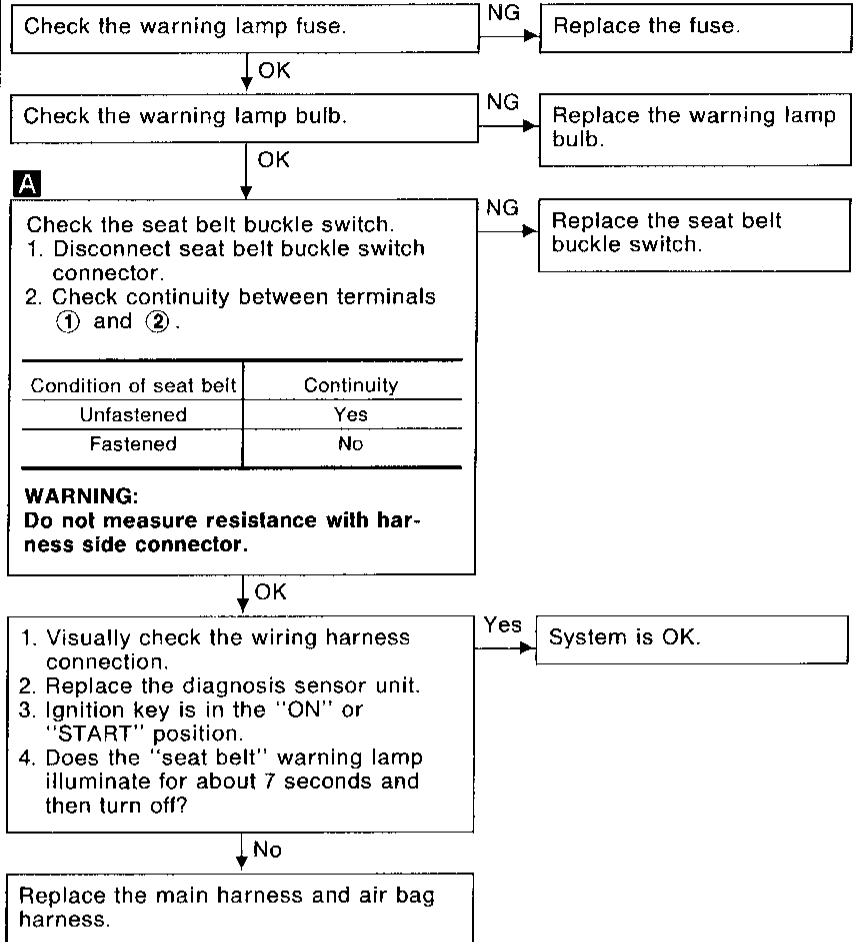
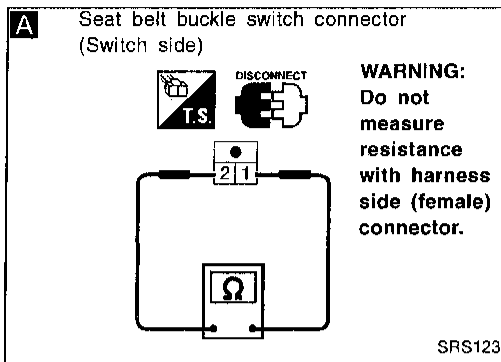

# COLLISION DIAGNOSIS

To repair the SRS, perform the following steps.

**When SRS is activated in a collision:**

- ① Replace the diagnosis sensor unit.
- ② Remove the air bag modules.
- ③ Check the SRS components using the table shown below:
  - Replace any SRS components showing visible signs of damage (dents, cracks, deformation).
- ④ Conduct self-diagnosis. Refer to "Self-diagnosis" for details (RS-25). Ensure the remainder of the SRS is operating properly.
- ⑤ Install new air bag modules.
- ⑥ Conduct self-diagnosis again.

**When SRS is not activated in a collision:**

- ① Check the SRS components using the table shown below:
  - Replace any SRS components showing visible signs of damage (dents, cracks, deformation).
- ② Conduct self-diagnosis using CONSULT and "AIR BAG" warning lamp. Refer to "Self-diagnosis" for details (RS-25). Ensure entire SRS operates properly.

**SRS inspection**

Part	SRS is activated	SRS is NOT activated
Air bag module (driver and passenger side)	REPLACE Install with new bolts.	1. Remove air bag module. Check harness cover and connectors for damage, terminals for deformities, and harness for binding. 2-1. Install driver air bag module into the steering wheel to check fit and alignment with the wheel. 2-2. Install passenger air bag module into the instrument panel to check fit with the instrument panel. 3. No damage found, reinstall with new bolts. 4. If damaged—REPLACE. Air bag must be deployed before discarding.
Instrument panel	REPLACE Install with new bolts.	1. Check instrument panel for bending, deformities, or cracks. 2. If no damage is found, reinstall with new bolts. 3. If damaged—REPLACE.
Seat belt pre-tensioner assembly	REPLACE Install with new bolts.	1. Remove seat belt pre-tensioners. Check harness cover and connectors for damage, terminals for deformities, and harness for binding. 2. Check belts for damage and anchors for loose mounting. 3. Check retractor for smooth operation. 4. If no damage is found, reinstall with new bolts. 5. If damaged—REPLACE.
Diagnosis sensor unit	REPLACE Install with new bolts.	1. Check case and bracket for dents, cracks or deformities. 2. Check connectors for damage, and terminals for deformities. 3. If no damage is found, reinstall with new bolts. 4. If damaged—REPLACE.
Steering wheel		1. Visually check steering wheel for deformities. 2. Check harness (built into steering wheel) and connectors for damage, and terminals for deformities. 3. Install air bag module to check fit or alignment with steering wheel. 4. Check steering wheel for excessive free play. 5. If no damage is found, reinstall with new bolts. 6. If damaged—REPLACE.
Spiral cable		1. Visually check lock (engagement) pins and combination switch for damage. 2. Check connectors, flat cable and protective tape for damage. 3. Check steering wheel for noise, binding or heavy operation. 4. If no damage is found, reinstall with new bolts. 5. If damaged—REPLACE.
Harness and Connectors		1. Check connectors for poor connection, damage, and terminals for deformities. 2. Check harness for binding, chafing, cuts, or deformities. 3. If no damage is found, reinstall harness and connectors. 4. Damaged—REPLACE damaged section of harness. Do not attempt to repair, splice or modify any SRS harness.

GI  
 MA  
 EM  
 LC  
 EC  
 FE  
 AT  
 PD  
 FA  
 RA  
 BR  
 ST  
 RS  
 BT  
 HA  
 EL  
 IDX