

A  
LU  
C  
D  
E

# SECTION LU

## ENGINE LUBRICATION SYSTEM

### CONTENTS

<b>PRECAUTIONS</b> .....	<b>2</b>	<b>OIL FILTER</b> .....	<b>8</b>	F
Precautions for Liquid Gasket .....	2	Removal and Installation .....	8	
<b>REMOVAL OF LIQUID GASKET SEALING</b> .....	2	<b>REMOVAL</b> .....	8	
<b>LIQUID GASKET APPLICATION PROCEDURE</b> .....	2	<b>INSTALLATION</b> .....	8	G
<b>PREPARATION</b> .....	<b>3</b>	<b>INSPECTION AFTER INSTALLATION</b> .....	8	
Special Service Tools .....	3	<b>OIL PUMP</b> .....	<b>9</b>	
Commercial Service Tools .....	3	Removal and Installation .....	9	H
<b>LUBRICATION SYSTEM</b> .....	<b>4</b>	<b>REMOVAL</b> .....	9	
Lubrication Circuit .....	4	<b>INSTALLATION</b> .....	9	
System Drawing .....	5	Disassembly and Assembly .....	10	
<b>ENGINE OIL</b> .....	<b>6</b>	<b>DISASSEMBLY</b> .....	10	I
Inspection .....	6	<b>INSPECTION AFTER DISASSEMBLY</b> .....	10	
<b>ENGINE OIL LEVEL</b> .....	6	<b>ASSEMBLY</b> .....	11	
<b>OIL APPEARANCE</b> .....	6	<b>SERVICE DATA AND SPECIFICATIONS (SDS)</b> .....	<b>12</b>	J
<b>OIL LEAKAGE</b> .....	6	Standard and Limit .....	12	
<b>OIL PRESSURE CHECK</b> .....	6	<b>OIL PRESSURE</b> .....	12	
Changing Engine Oil .....	7	<b>OIL PUMP</b> .....	12	K
		<b>REGULATOR VALVE</b> .....	12	
		<b>ENGINE OIL CAPACITY</b> .....	12	L
		Tightening torque .....	12	

M

# PRECAUTIONS

PFP:00001

## PRECAUTIONS

### Precautions for Liquid Gasket REMOVAL OF LIQUID GASKET SEALING

ABS000P2

- After removing the mounting bolts and nuts, separate the mating surface using a seal cutter and remove the liquid gasket sealing.

#### **CAUTION:**

**Be careful not to damage the mating surfaces.**

- In areas where the cutter is difficult to use, use a plastic hammer to lightly tap the areas where the liquid gasket is applied.

#### **CAUTION:**

**If for some unavoidable reason a tool such as a flat-bladed screwdriver is used, be careful not to damage the mating surfaces.**

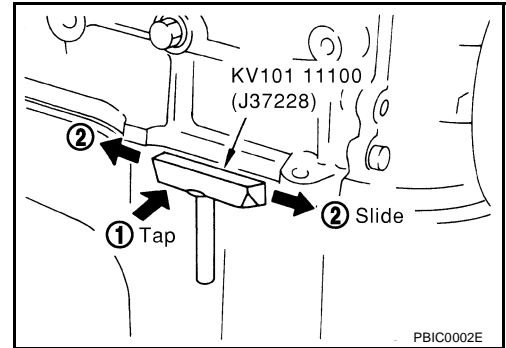

### LIQUID GASKET APPLICATION PROCEDURE

1. Using a scraper, remove the old liquid gasket adhering to the gasket application surface and the mating surface.
  - Remove the liquid gasket completely from the groove of the liquid gasket application surface, mounting bolts, and bolt holes.
2. Wipe the gasket application surface and the mating surface removing any adhering moisture, grease and foreign material.
3. Attach the liquid gasket tube to the tube presser.  
**Use Genuine RTV Silicone Sealant or equivalent. Refer to [GI-46. "RECOMMENDED CHEMICAL PRODUCTS AND SEALANTS"](#).**

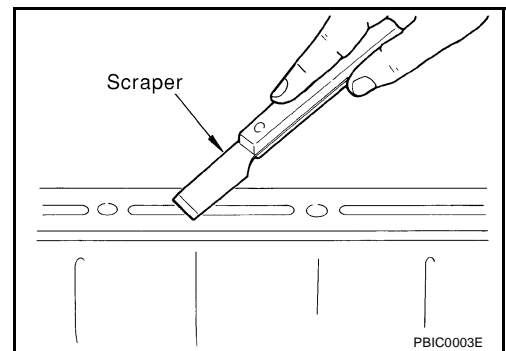

4. Apply the liquid gasket without breaks to the specified location with the specified dimensions.
  - If there is a groove for the liquid gasket application, apply the liquid gasket to the groove.

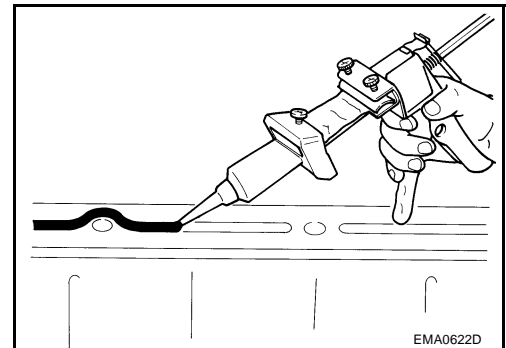

- As for the bolt holes, normally apply the gasket inside the holes. Occasionally, it should be applied outside the holes. Make sure to read the text of this manual.
- Within five minutes of liquid gasket application, install the mating component.
- If the liquid gasket protrudes, wipe it off immediately.
- Do not retighten after the installation.
- Wait 30 minutes or more after installation before refilling the engine with oil and coolant.

#### **CAUTION:**

**If there are specific instructions in this manual, observe them.**

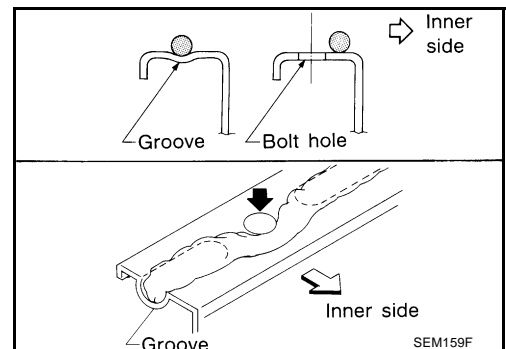

# PREPARATION

## PREPARATION

PF0:00002

### Special Service Tools

ABS000M7

The actual shapes of Kent-Moore tools may differ from those of special service tools illustrated here.

Tool number (Kent-Moore No.) Tool name	Description
ST25051001 (J25695-1) Oil pressure gauge	Measuring oil pressure <b>Maximum measuring range:</b> <b>2,452 kPa (25 kg/cm<sup>2</sup> , 356 psi)</b>
ST25052000 (J25695-2) Hose	Adapting oil pressure gauge to cylinder block
KV10115801 (J38956) Oil filter wrench	Removing and installing oil filter a : 64.3 mm (2.531 in)
WS39930000 ( — ) Tube presser	Pressing the tube of liquid gasket

## Commercial Service Tools

ABS000M8

Tool name	Description
Power tool	Loosening bolts and nuts
Deep socket	Removing and installing oil pressure switch Deep socket 26mm (1.02in)

# LUBRICATION SYSTEM

## LUBRICATION SYSTEM

PFP:15010

### Lubrication Circuit

ABS000M9

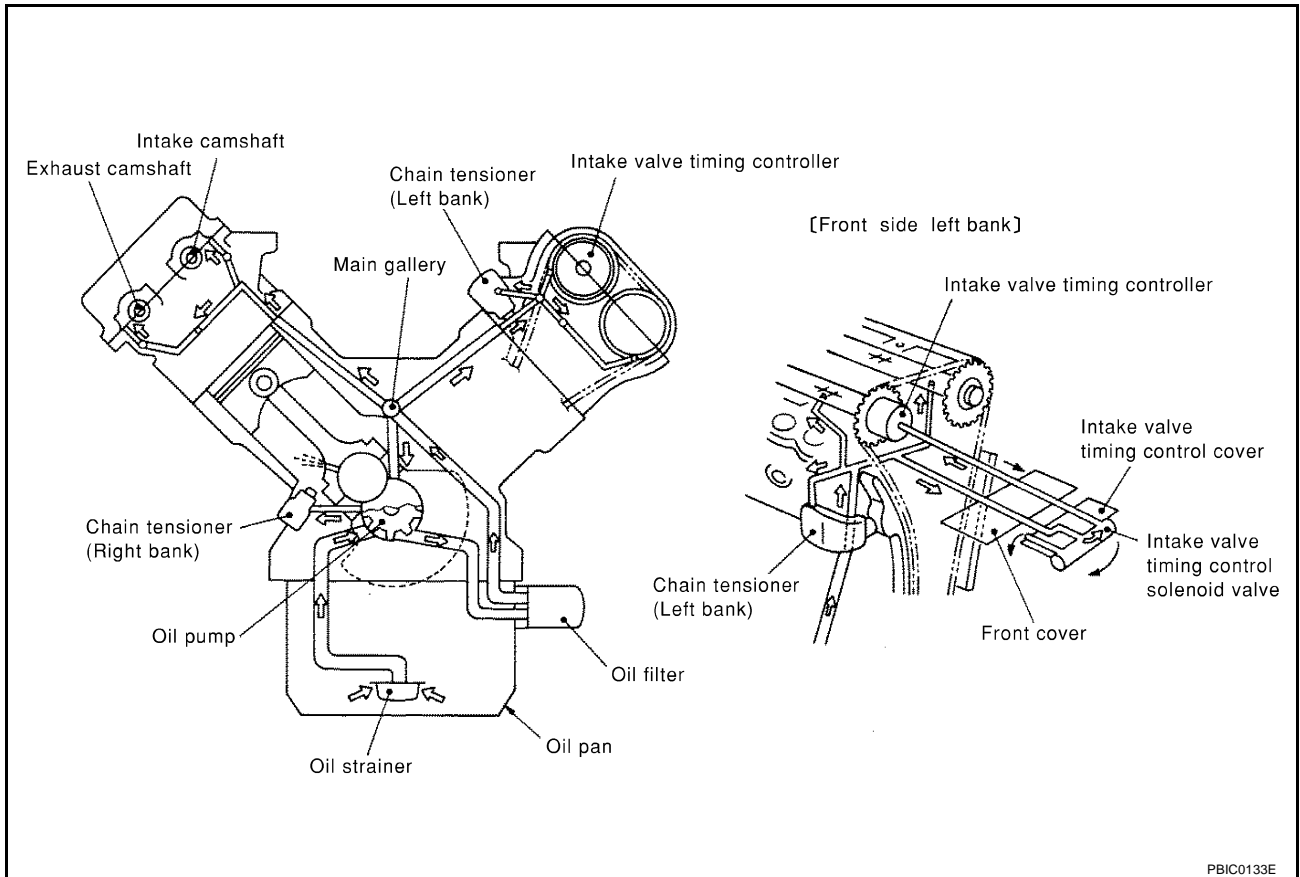

PBIC0133E

# LUBRICATION SYSTEM

## System Drawing

ABS000MA

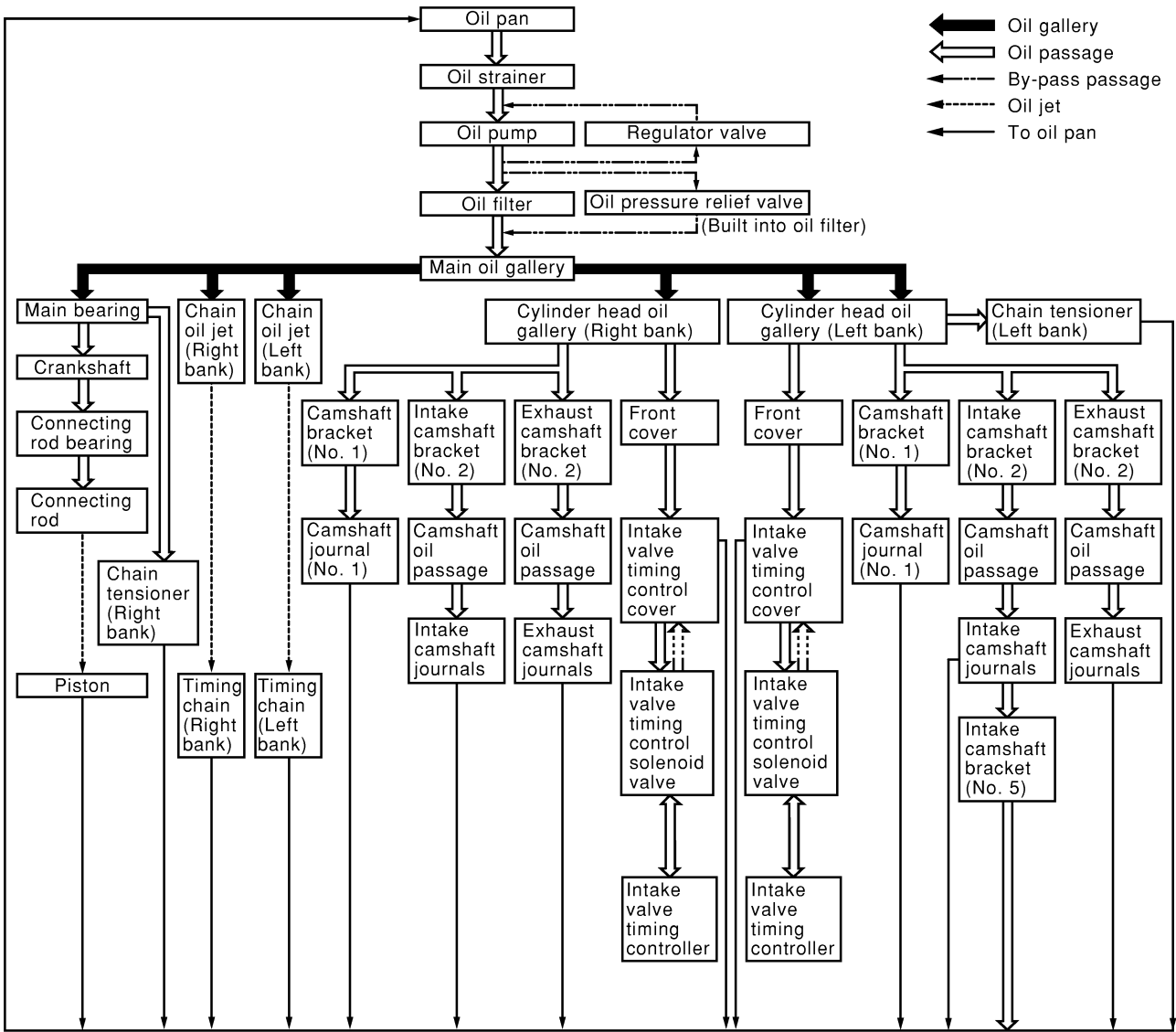

PBIC0134E

A  
LU  
C  
D  
E  
F  
G  
H  
I  
J  
K  
L  
M

## ENGINE OIL

PFK:KLA92

### Inspection ENGINE OIL LEVEL

ABS000MB

#### NOTE:

Before starting the engine, check the engine oil level. If the engine is already started, stop it and allow 15 minutes before checking.

1. Put vehicle horizontally.
2. Pull out oil level gauge and wipe it clean.
3. Insert oil level gauge and check that the engine oil level is within the range shown in the figure.
4. If it is out of range, adjust it.

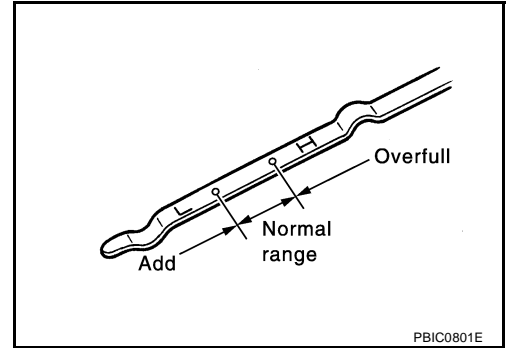

### OIL APPEARANCE

- Check the engine oil for a white milky appearance or excessive contamination.
- If the engine oil is milky, it is highly probable that it is contaminated with engine coolant. Repair the broken parts.

### OIL LEAKAGE

Check for oil leakage around the following area.

- Oil pan
- Oil pan drain plug
- Oil pressure switch
- Oil filter
- Intake valve timing control cover
- Front cover
- Mating surface between cylinder block and cylinder head
- Mating surface between cylinder head and rocker cover
- Crank oil seal (front and rear)

### OIL PRESSURE CHECK

#### WARNING:

- Be careful not to burn yourself, as the engine oil is hot.
  - Oil pressure check should be done in "Parking position".
1. Check the engine oil level. Refer to [LU-6, "Inspection"](#).
  2. Remove the engine under cover with power tool.
  3. Remove the oil pressure switch to connect the oil pressure gauge.
  4. After warming up the engine, check that oil pressure corresponding to the engine speed is produced.

#### NOTE:

When engine oil temperature is low, the engine oil pressure becomes high.

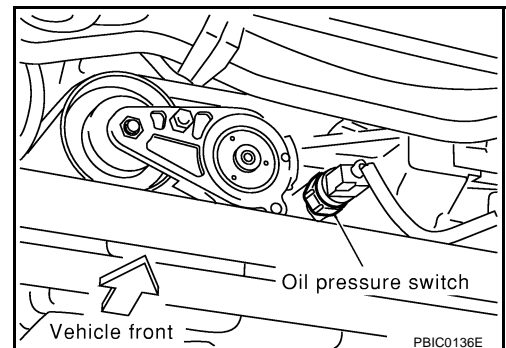

# ENGINE OIL

## Engine oil pressure [Oil temperature is 80 °C (176 °F)]

Engine speed (rpm)	Idle speed	2,000	6,000
Oil pressure kPa (kg/cm <sup>2</sup> , psi)	Approx. 98 (1.0, 14) or more	Approx. 294 (3.0, 43) or more	Approx. 392 (4.0, 57) or more

If difference is extreme, check oil passage and oil pump for oil leaks.

5. After the inspections, install the oil pressure switch as follows.
  - a. Remove the old liquid gasket adhering to oil pressure switch and mating surface.
  - b. Apply thread sealant and tighten the oil pressure switch to specification.

**Use Genuine Thread Sealant or equivalent. Refer to [GI-46, "RECOMMENDED CHEMICAL PRODUCTS AND SEALANTS"](#) .**

**Oil pressure switch:**

: **12.3 - 17.2 N·m (1.25 - 1.75 kg-m, 10 - 12 ft-lb)**

## Changing Engine Oil

ABS000MC

### WARNING:

- Be careful not to burn yourself, as the engine oil is hot.
- Prolonged and repeated contact with used engine oil may cause skin cancer; try to avoid direct skin contact with used engine oil. If skin contact is made, wash thoroughly with soap or hand cleaner as soon as possible.

1. Remove the engine under cover with power tool.
2. Warm up engine, and check for oil leakage from engine components.
3. Stop engine and wait for 15 minutes.
4. Remove drain plug and oil filler cap.
5. Drain engine oil.
6. Install drain plug with new washer. Refer to [EM-25, "OIL PAN AND OIL STRAINER"](#) .
7. Refill with new engine oil.

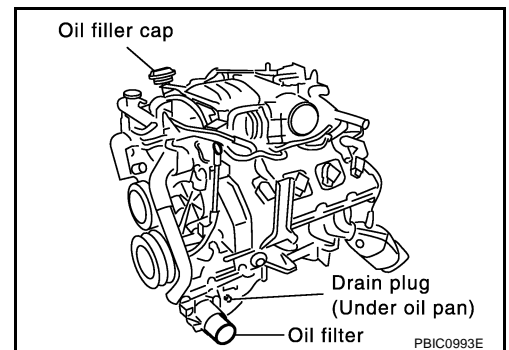

### Engine oil specification and viscosity :

Refer to [MA-11, "RECOMMENDED FLUIDS AND LUBRICANTS"](#) for further detail.

### Oil capacity (Approximate):

Unit: Liter (US qt, Imp qt)

Drain and refill	With oil filter change	Approximately 5.6 (5-7/8, 4-7/8)
	Without oil filter change	Approximately 5.0 (5-1/4, 4-3/8)
Dry engine (engine overhaul)		Approximately 6.7 (7-1/8, 5-7/8)

### CAUTION:

- Be sure to clean drain plug and install with new washer.

#### Oil pan drain plug:

: **29.4 - 39.2 N·m (3.0 - 4.0 kg-m, 22 - 28 ft-lb)**

- The refill capacity depends on the engine oil temperature and drain time. Use these specifications for reference only.
  - Always use the oil level gauge to determine when the proper amount of oil is in the engine.
8. Warm up engine and check area around drain plug and oil filter for oil leakage.
  9. Stop engine and wait for 15 minutes.
  10. Check engine oil level. Refer to [LU-6, "Inspection"](#) .

# OIL FILTER

PFP:15208

ABS000MD

## OIL FILTER

### Removal and Installation

#### REMOVAL

1. Open the oil filter installation/removal cover on the undercover.
2. Using an oil filter wrench, remove the oil filter.

#### CAUTION:

- The oil filter is provided with a relief valve. Use genuine NISSAN oil filter or equivalent.
- Be careful not to get burned when the engine and engine oil are hot.
- When removing, prepare a shop cloth to absorb any engine-oil leakage or spillage.
- Do not allow engine oil to adhere to the drive belts.
- Completely wipe off any engine oil that adhere to the engine and the vehicle.

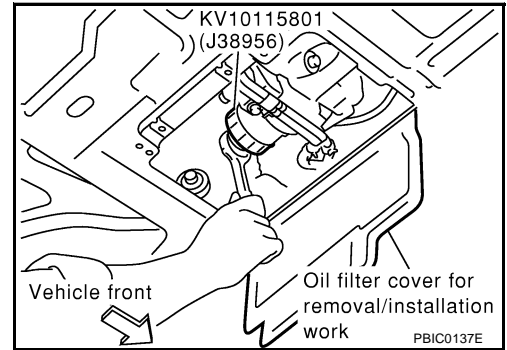

#### INSTALLATION

1. Remove foreign materials adhering to the oil filter installation surface.
2. Apply engine oil to the oil seal circumference of the new oil filter.

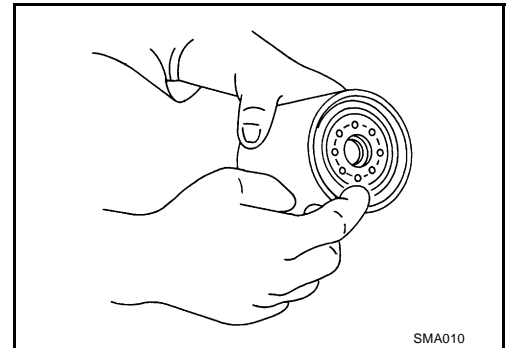

3. Screw the oil filter manually until it touches the installation surface, then tighten it by 2/3 turn.

#### Oil filter:

 :14.7 - 20.6 N·m (1.5 - 2.1 kg-m, 11 - 15 ft-lb)

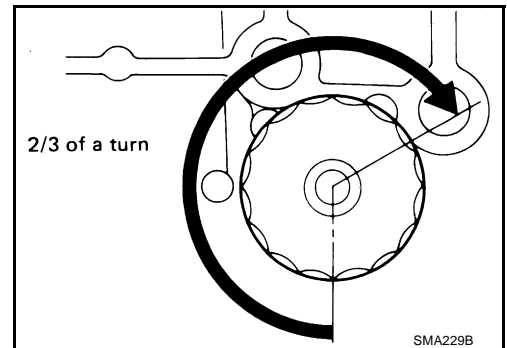

#### INSPECTION AFTER INSTALLATION

1. After warming up the engine, check for engine oil leakage.
2. Stop engine and wait for 15 minutes.
3. Check engine oil level and add engine oil. Refer to [LU-6, "ENGINE OIL"](#).



# OIL PUMP

## OIL PUMP

PFP:15010

### Removal and Installation

ABS000ME

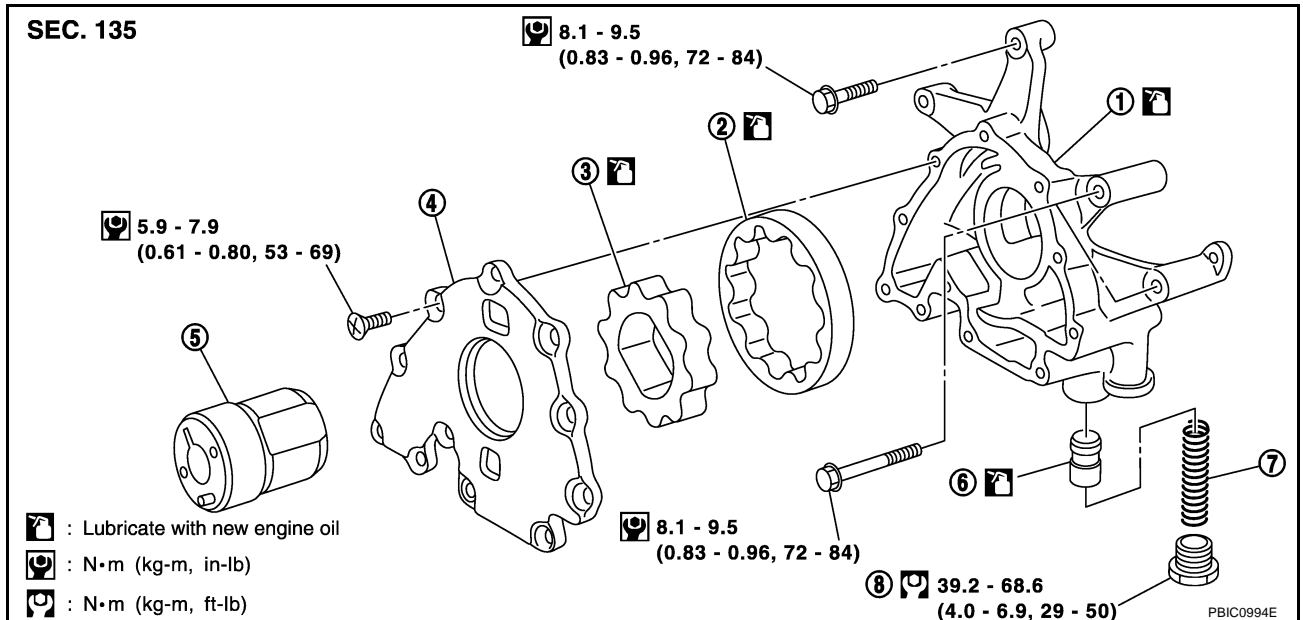

- |                     |                          |                    |
|---------------------|--------------------------|--------------------|
| 1. Oil pump body    | 2. Outer rotor           | 3. Inner rotor     |
| 4. Oil pump cover   | 5. Oil pump drive spacer | 6. Regulator valve |
| 7. Regulator spring | 8. Regulator plug        |                    |

### CAUTION:

Before installation, apply new engine oil to the parts as instructed in the figure.

### REMOVAL

- Remove front cover.  
Refer to [EM-35, "Removal and Installation"](#).
- Remove the oil pump drive spacer.
  - Set bolts in the two bolt holes [M6 x 1.0 mm (0.039 in)] on the front surface. Using a small puller, remove the oil pump drive spacer from the crankshaft.

### NOTE:

The dimension between the centers of the two bolt holes is 33 mm (1.30 in).

In the figure, a commercial steering puller is used.

- Remove the oil pump.

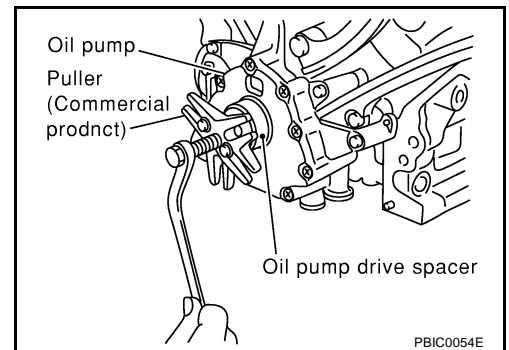

### INSTALLATION

- Install the oil pump.
- Install the oil pump drive spacer as follows.
  - When inserting the oil pump drive spacer, align the crankshaft key and the flat face of the inner rotor.
    - If they are not aligned, rotate the oil pump inner rotor by hand.
  - Make sure that the each part is aligned. Using a tool such as a plastic hammer, tap lightly until it reaches the end.
- Install in the reverse order of removal.

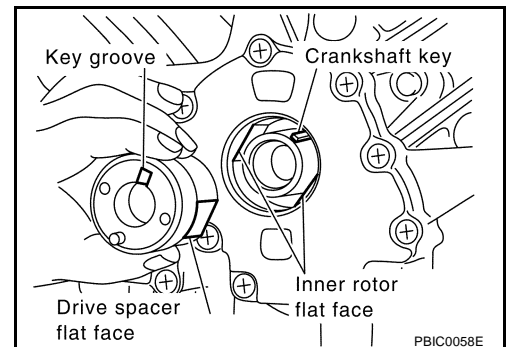

# OIL PUMP

ABS000MF

## Disassembly and Assembly DISASSEMBLY

1. Remove oil pump cover.
2. Remove inner rotor and outer rotor from front cover.
3. After removing regulator plug, remove regulator spring and regulator valve.

## INSPECTION AFTER DISASSEMBLY

### Clearance of Oil Pump Parts

- Measure clearance with feeler gauge.  
Clearance between outer rotor and oil pump body (position 1)  
**Standard : 0.114 - 0.200 mm (0.0045 - 0.0079 in)**  
Tip clearance between inner rotor and outer rotor (position 2)  
**Standard : Below 0.180 mm (0.0071in)**

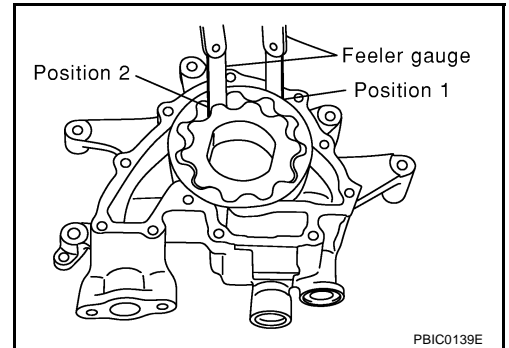

- Measure clearance with feeler gauge and straightedge.  
Side clearance between inner rotor and oil pump body (position 3)  
**Standard : 0.030 - 0.070 mm (0.0012 - 0.0028 in)**  
Side clearance between outer rotor and oil pump body (position 4)  
**Standard : 0.030 - 0.090 mm (0.0012 - 0.0035 in)**

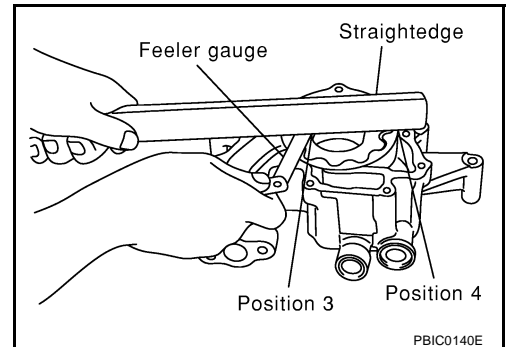

- Calculate the clearance between inner rotor and oil pump body as follows.
  1. Measure the outer diameter of protruded portion of inner rotor (Position 5)

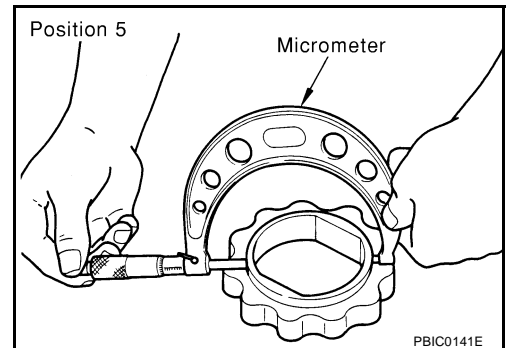

2. Measure the inner diameter of oil pump body with inside micrometer (Position 6)  
(Clearance) = (Inner diameter of oil pump body) – (Outer diameter of inner rotor)

**Standard : 0.045 - 0.091 mm (0.0018 - 0.0036 in)**

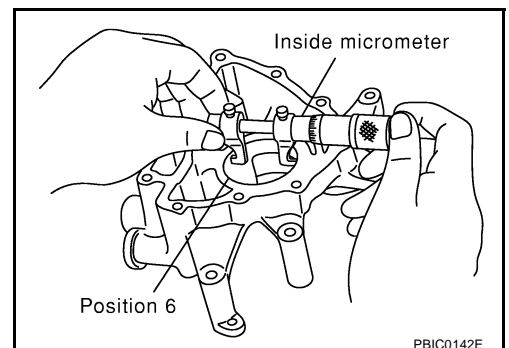

# OIL PUMP

## Regulator Valve Clearance

(Clearance) = D1 (Valve hole diameter) – D2 (Outer diameter of valve)

**Standard : 0.040 - 0.097 mm (0.0016 - 0.0038 in)**

### CAUTION:

- Coat regulator valve with engine oil.
- Check that it falls smoothly into the regulator valve hole by its own weight.

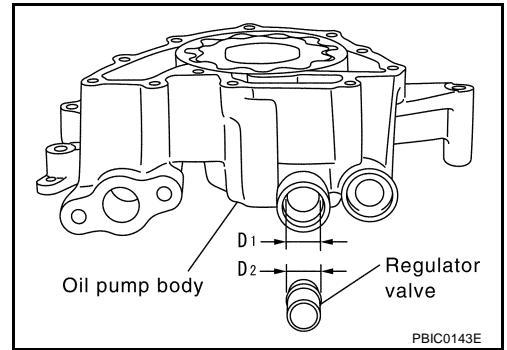

## ASSEMBLY

- Installation is in the reverse order of removal.
- Install the inner rotor and outer rotor with the punched marks on the oil pump cover side.

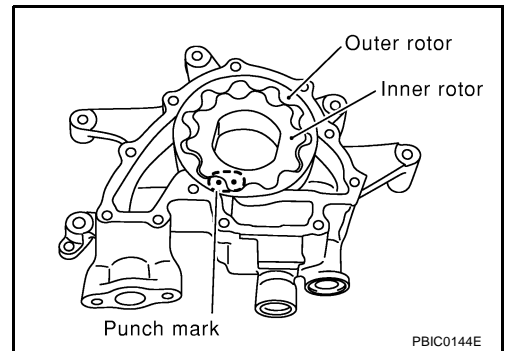

A  
LU  
C  
D  
E  
F  
G  
H  
I  
J  
K  
L  
M

# SERVICE DATA AND SPECIFICATIONS (SDS)

## SERVICE DATA AND SPECIFICATIONS (SDS)

PFP:00030

### Standard and Limit OIL PRESSURE

ABS000MG

Engine speed rpm	Approximate discharge pressure kPa (kg/cm <sup>2</sup> , psi)
Idle speed 2,000 6,000	More than 98 (1.0, 14) 294 (3.0, 43) 392 (4.0, 57)

### OIL PUMP

Unit: mm (in)

Body to outer rotor radial clearance	0.114 - 0.200 (0.0045 - 0.0079)
Inner rotor to outer rotor tip clearance	Below 0.18 (0.0071)
Body to inner rotor axial clearance	0.030 - 0.070 (0.0012 - 0.0028)
Body to outer rotor axial clearance	0.030 - 0.090 (0.0012 - 0.0035)
Inner rotor to brazed portion of housing clearance	0.045 - 0.091 (0.0018 - 0.0036)

### REGULATOR VALVE

Unit: mm (in)

Regulator valve to oil pump cover clearance	0.040 - 0.097 (0.0016 - 0.0038)
---	---------------------------------

### ENGINE OIL CAPACITY

Unit: ℓ (US qt, Imp qt)

With oil filter change	Approximately 5.6 (5-7/8, 4-7/8)
Without oil filter change	Approximately 5.0 (5-1/4, 4-3/8)
Dry engine (engine overhaul)	Approximately 6.7 (7-1/8, 5-7/8)

### Tightening torque

ABS000MH

Unit: N·m (kg-m, ft-lb)  
Unit: N·m (kg-m, in-lb)\*

Oil pressure switch	12.3 - 17.2 (1.25 - 1.75, 10 - 12)
Oil pan drain plug	29.4 - 39.2 (3.0 - 4.0, 22 - 28)
Oil filter	14.7 - 20.6 (1.5 - 2.1, 11 - 15)
Oil pump body	8.1 - 9.5 (0.83 - 0.96, 72 - 84)*
Oil pump cover	5.9 - 7.9 (0.61 - 0.80, 53 - 69)*
Regulator plug	39.2 - 68.6 (4.0 - 6.9, 29 - 50)