

A
B
C
D
E
F
G
H
I
J
L
M

WW

SECTION

WIPER, WASHER & HORN

CONTENTS

| | |
|---|--|
| <p>PRECAUTION 3</p> <p> Precautions for Supplemental Restraint System (SRS) "AIR BAG" and "SEAT BELT PRE-TENSIONER" 3</p> <p> Wiring Diagrams and Trouble Diagnosis 3</p> <p>FRONT WIPER AND WASHER SYSTEM 4</p> <p> System Description 4</p> <p> WIPER OPERATION 4</p> <p> WASHER OPERATION 5</p> <p> Component Parts and Harness Connector Location... 5</p> <p> Schematic 6</p> <p> Wiring Diagram — WIPER — 7</p> <p> Terminal and Reference Values for BCM 10</p> <p> Work Flow 10</p> <p> Preliminary Inspection 11</p> <p> SETTING CHANGE FUNCTIONS 11</p> <p> INSPECTION FOR POWER SUPPLY AND GROUND CIRCUIT 11</p> <p> CONSULT-II Function 12</p> <p> CONSULT-II BASIC OPERATION PROCEDURE 12</p> <p> WORK SUPPORT 13</p> <p> DATA MONITOR 13</p> <p> ACTIVE TEST 13</p> <p> On Board Diagnosis 14</p> <p> DIAGNOSIS ITEM FOR FRONT WIPER AND WASHER SYSTEM 14</p> <p> SWITCH MONITOR 14</p> <p> Intermittent Wiper Does Not Operate 15</p> <p> Intermittent Time Of Wiper Cannot Be Adjusted ... 17</p> <p> Wiper And Washer Activate Individually But Not In Combination 17</p> <p> Intermittent Wiper Operates, But There Is No Change In Intermittent Time Between When Vehicle Is Stopped And Moving 18</p> <p> Wiper And Washer Activate Individually But Intermittent Wiper And Washer Combination Does Not Operate 19</p> <p> Wiper and Washer Switch Circuit Check 20</p> <p> INSPECTION OF SWITCH CIRCUIT 20</p> | <p> Removal and Installation for Front Wiper Arms, Adjustment for Wiper Arms Stop Location 20</p> <p> REMOVAL 20</p> <p> INSTALLATION 20</p> <p> ADJUSTMENT 21</p> <p> Removal and Installation of Front Wiper Motor and Linkage 21</p> <p> REMOVAL 21</p> <p> INSTALLATION 21</p> <p> Disassembly and Assembly Front Wiper Motor and Linkage 22</p> <p> DISASSEMBLY 22</p> <p> ASSEMBLY 22</p> <p> Washer Nozzle Adjustment 22</p> <p> Washer Tube Layout 23</p> <p> Removal and Installation for Front Washer Nozzle.. 24</p> <p> REMOVAL 24</p> <p> INSTALLATION 24</p> <p> Inspection for Washer Nozzle 24</p> <p> CHECK VALVE 24</p> <p> Removal and Installation for Front Wiper and Washer Switch 24</p> <p> REMOVAL 24</p> <p> INSTALLATION 24</p> <p> Removal and Installation for Washer Tank 25</p> <p> REMOVAL 25</p> <p> INSTALLATION 25</p> <p> Removal and Installation for Washer Pump 25</p> <p> REMOVAL 25</p> <p> INSTALLATION 25</p> <p> CIGARETTE LIGHTER 26</p> <p> Wiring Diagram — CIGAR — 26</p> <p> Removal and Installation 27</p> <p> REMOVAL 27</p> <p> INSTALLATION 27</p> <p> POWER SOCKET 28</p> <p> Wiring Diagram — CIGAR — 28</p> <p> Removal and Installation 29</p> <p> REMOVAL 29</p> <p> INSTALLTION 29</p> |
|---|--|

| | | | |
|-------------------|-----------|--------------------------------|----|
| HORN | 30 | Wiring Diagram — HORN — | 30 |
| | | Removal and installation | 31 |
| | | REMOVAL | 31 |
| | | INSTALLATION | 31 |

PRECAUTION

PRECAUTION

PPF:00011

Precautions for Supplemental Restraint System (SRS) “AIR BAG” and “SEAT BELT PRE-TENSIONER”

AKS004VC

The Supplemental Restraint System such as “AIR BAG” and “SEAT BELT PRE-TENSIONER”, used along with a front seat belt, helps to reduce the risk or severity of injury to the driver and front passenger for certain types of collision. This system includes seat belt switch inputs and dual stage front air bag modules. The SRS system uses the seat belt switches to determine the front air bag deployment, and may only deploy one front air bag, depending on the severity of a collision and whether the front occupants are belted or unbelted. Information necessary to service the system safely is included in the SRS and SB section of this Service Manual.

WARNING:

- To avoid rendering the SRS inoperative, which could increase the risk of personal injury or death in the event of a collision which would result in air bag inflation, all maintenance must be performed by an authorized NISSAN/INFINITI dealer.
- Improper maintenance, including incorrect removal and installation of the SRS, can lead to personal injury caused by unintentional activation of the system. For removal of Spiral Cable and Air Bag Module, see the SRS section.
- Do not use electrical test equipment on any circuit related to the SRS unless instructed to in this Service Manual. SRS wiring harnesses can be identified by yellow and/or orange harnesses or harness connectors.

Wiring Diagrams and Trouble Diagnosis

AKS002L7

When you read wiring diagrams, refer to the following:

- Refer to [GI-14, "How to Read Wiring Diagrams"](#) .
- Refer to [PG-2, "POWER SUPPLY ROUTING"](#) for power distribution circuit.

When you perform trouble diagnosis, refer to the following:

- Refer to [GI-10, "HOW TO FOLLOW TEST GROUPS IN TROUBLE DIAGNOSES"](#) .
- Refer to [GI-26, "How to Perform Efficient Diagnosis for an Electrical Incident"](#) .

A

B

C

D

E

F

G

H

I

J

WW

L

M

FRONT WIPER AND WASHER SYSTEM

FRONT WIPER AND WASHER SYSTEM

PFP:28810

System Description

AKS002L8

WIPER OPERATION

Description

With the ignition switch in the ON position, power is supplied

- through 20A fuse [No. 34, located in the fuse block (J/B) No.2]
- to front wiper motor terminal 4, and
- to front wiper relay terminal 1.

Ground is supplied to front wiper switch terminal 17 and 20 through body grounds M25 and M115.

Low (MIST) and High Speed Wiper Operation

When the wiper switch is placed in the LO or MIST position, ground is supplied

- through terminal 14 of the front wiper switch
- to front wiper motor terminal 6.

With power and ground supplied, the front wiper motor operates at low speed.

When the front wiper switch is placed in the HI position, ground is supplied

- through terminal 16 of the front wiper switch
- to front wiper motor terminal 5.

With power and ground supplied, the front wiper motor operates at high speed.

Auto Stop Operation

When the front wiper switch is placed in the OFF position, the front wiper motor will continue to operate until the wiper arms reach the base of the windshield (Auto stop). When the front wiper switch is placed in the OFF position, ground is supplied

- from terminal 14 of the front wiper switch
- to front wiper motor terminal 6, in order to continue front wiper motor operation at low speed.

Ground is also supplied until the wiper arms reaches the base of the windshield

- through terminal 13 of the front wiper switch
- to front wiper relay terminal 3
- through terminal 4 of the front wiper relay
- to front wiper motor terminal 3
- through terminal 1 of the front wiper motor, and
- through body grounds E24, E42 and E62.

When the wiper arms reach the base of the windshield, the switch in the front wiper motor moves to the "STOP" position. The ground path is interrupted and the front wiper motor stops.

Intermittent Operation

Intermittent operation is controlled by the BCM. When the front wiper switch is placed in the INT position, ground is supplied

- to BCM terminal 9
- from front wiper switch terminal 15
- through body grounds M25 and M115.

The desired interval time is input

- to BCM terminal 48
- from front wiper switch terminal 19 and
- to BCM terminal 49
- from combination meter terminal 38 (vehicle speed pulse).

The desired interval time is input

- to front wiper relay terminal 2
- to BCM terminal 128

With power and ground supplied, the front wiper relay is activated. When activated, an intermittent ground is supplied

FRONT WIPER AND WASHER SYSTEM

- to front wiper motor terminal 6
- through the front wiper switch terminal 14
- to front wiper switch terminal 13
- through front wiper relay terminal 3
- to front wiper relay terminal 5
- through body grounds E24, E42 and E62.

Front wiper motor operates at desired interval with BCM terminal 9 grounded. Intermittent operation can be adjusted from: Approx. 0.9 - 45 sec.: (when vehicle is stopped) Approx. 0.4 - 30 sec.: (when vehicle is moving)
Judgement on vehicle stopped or moving: Stopped, Moving: More than 5 km/h (3 MPH) Moving, Stopped: Less than 2 km/h (1 MPH)

WASHER OPERATION

With the ignition switch in the ON position, power is supplied

- through 20A fuse [No. 34, located in the fuse block (J/B) No.2]
- to front washer motor terminal 1.

When the lever is pulled to the WASH position, ground is supplied

- to front washer motor terminal 2, and
- to BCM terminal 4
- from terminal 18 of the front wiper switch
- through terminal 17 of the front wiper switch, and
- through body grounds M25 and M115.

With power and ground supplied, the front washer motor operates. The front wiper motor operates at low speed for about 3 seconds. This feature is controlled by the BCM in the same manner as the intermittent operation.

Component Parts and Harness Connector Location

AKS002L9

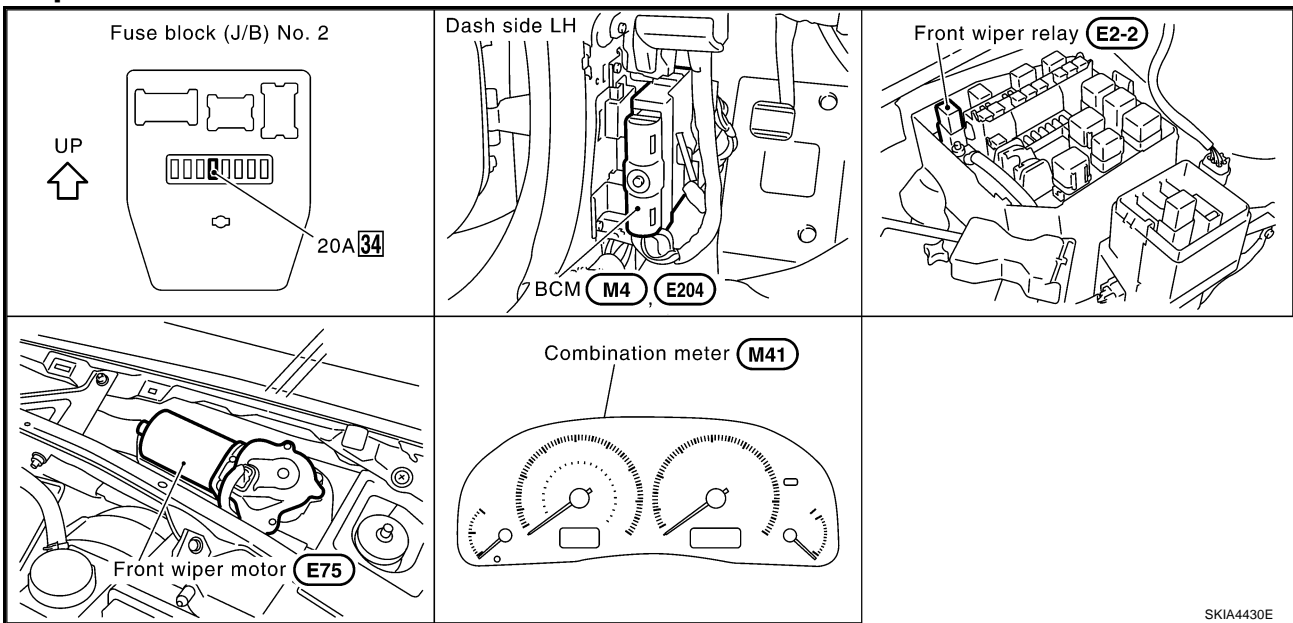

A
B
C
D
E
F
G
H
I
J
L
M

WW

FRONT WIPER AND WASHER SYSTEM

Schematic

AKS002LA

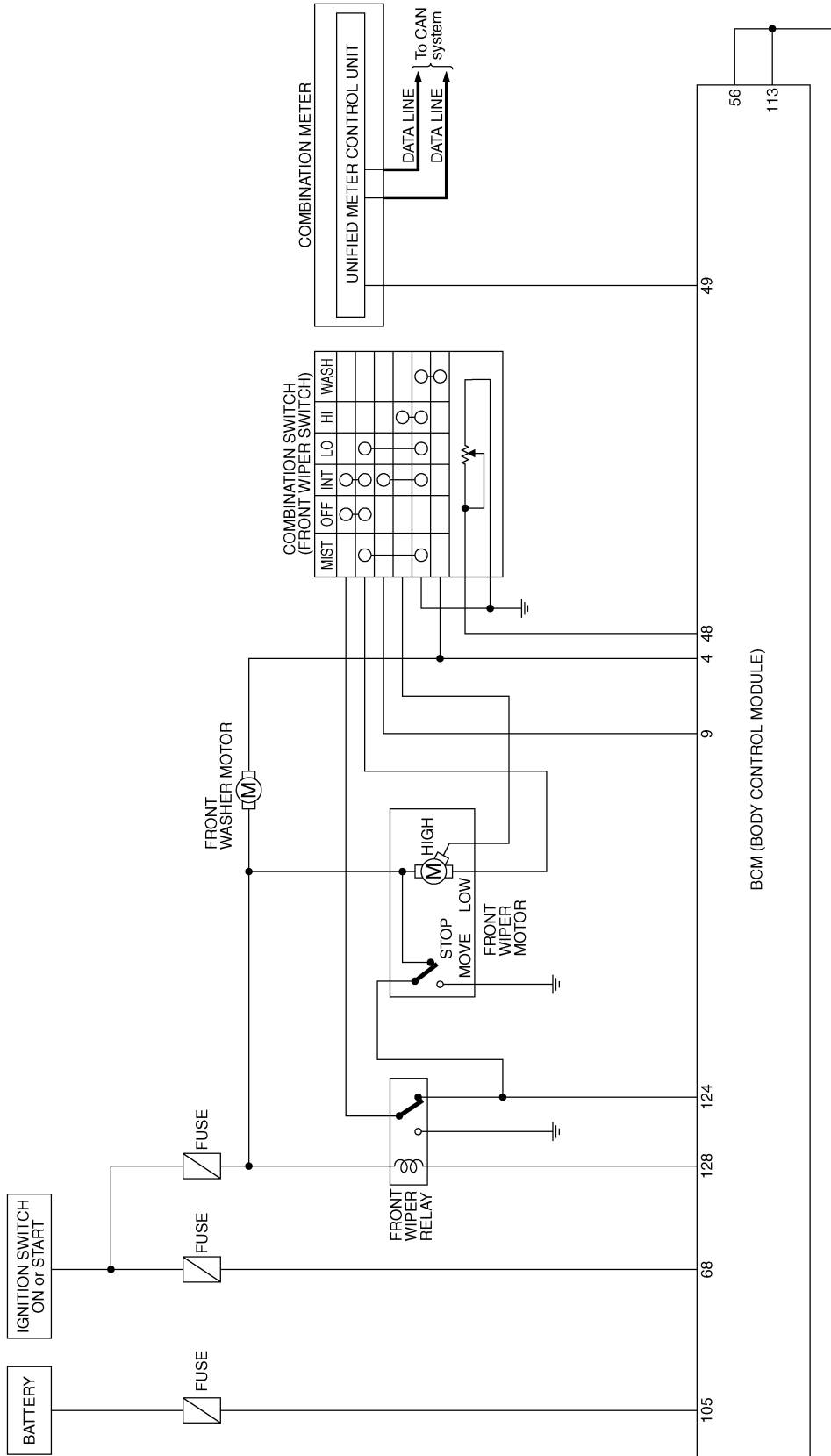

TKWA0626E

FRONT WIPER AND WASHER SYSTEM

Wiring Diagram — WIPER —

AKS002LB

WW-WIPER-01

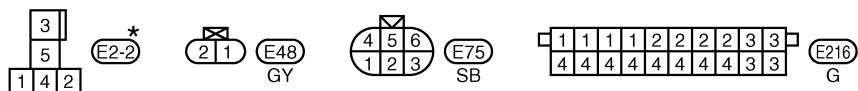
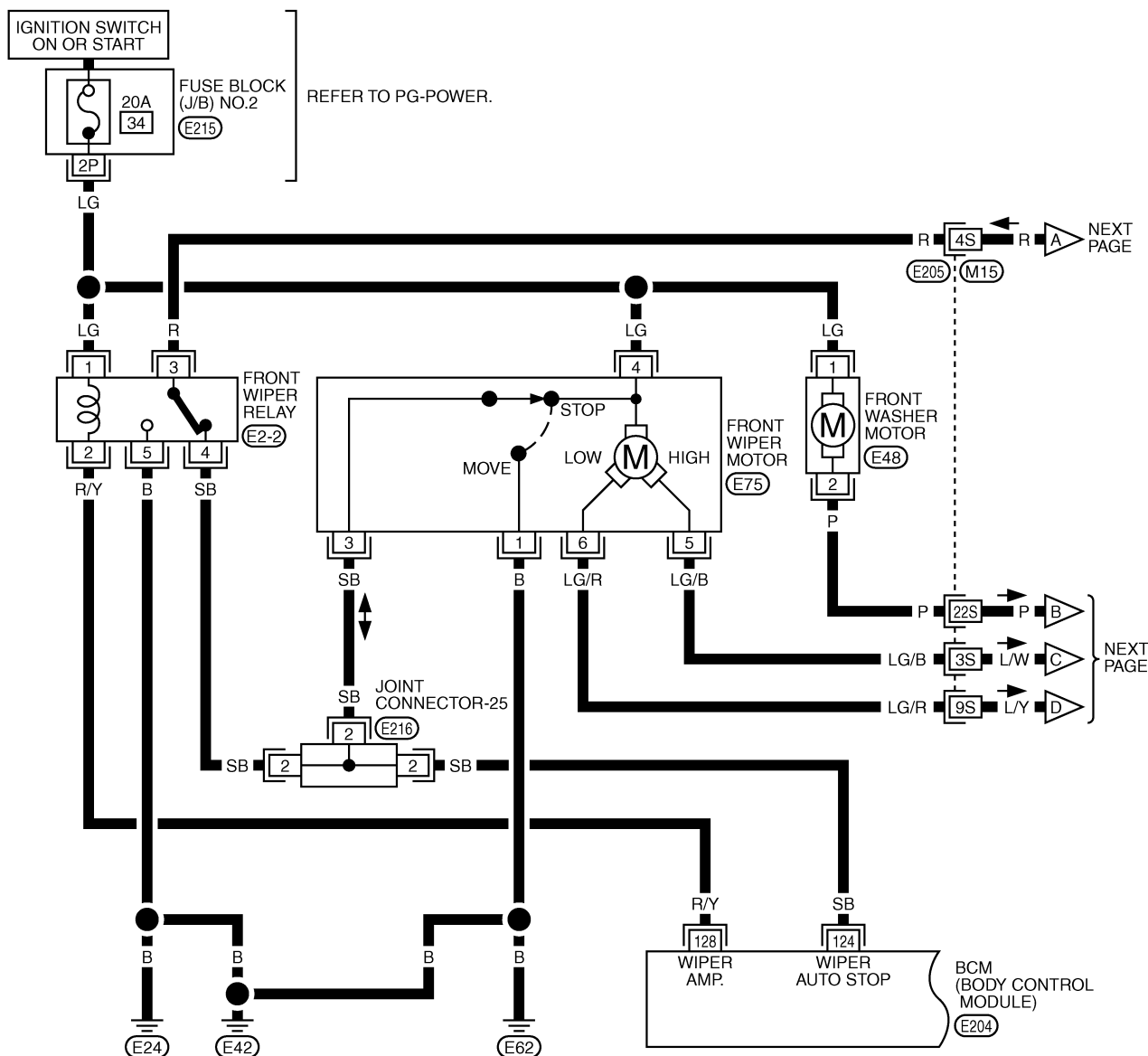

*: THIS CONNECTOR IS NOT SHOWN IN "HARNES LAYOUT", PG SECTION.

REFER TO THE FOLLOWING.

- (E205) -SUPER MULTIPLE JUNCTION (SMJ)
- (E215) -FUSE BLOCK-JUNCTION BOX (J/B) NO.2
- (E204) -ELECTRICAL UNITS

TKWA0627E

FRONT WIPER AND WASHER SYSTEM

WW-WIPER-03

▬ : DATA LINE

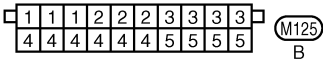
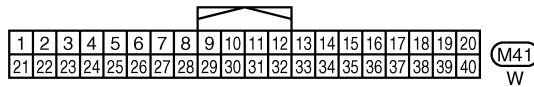
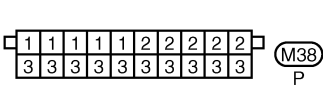
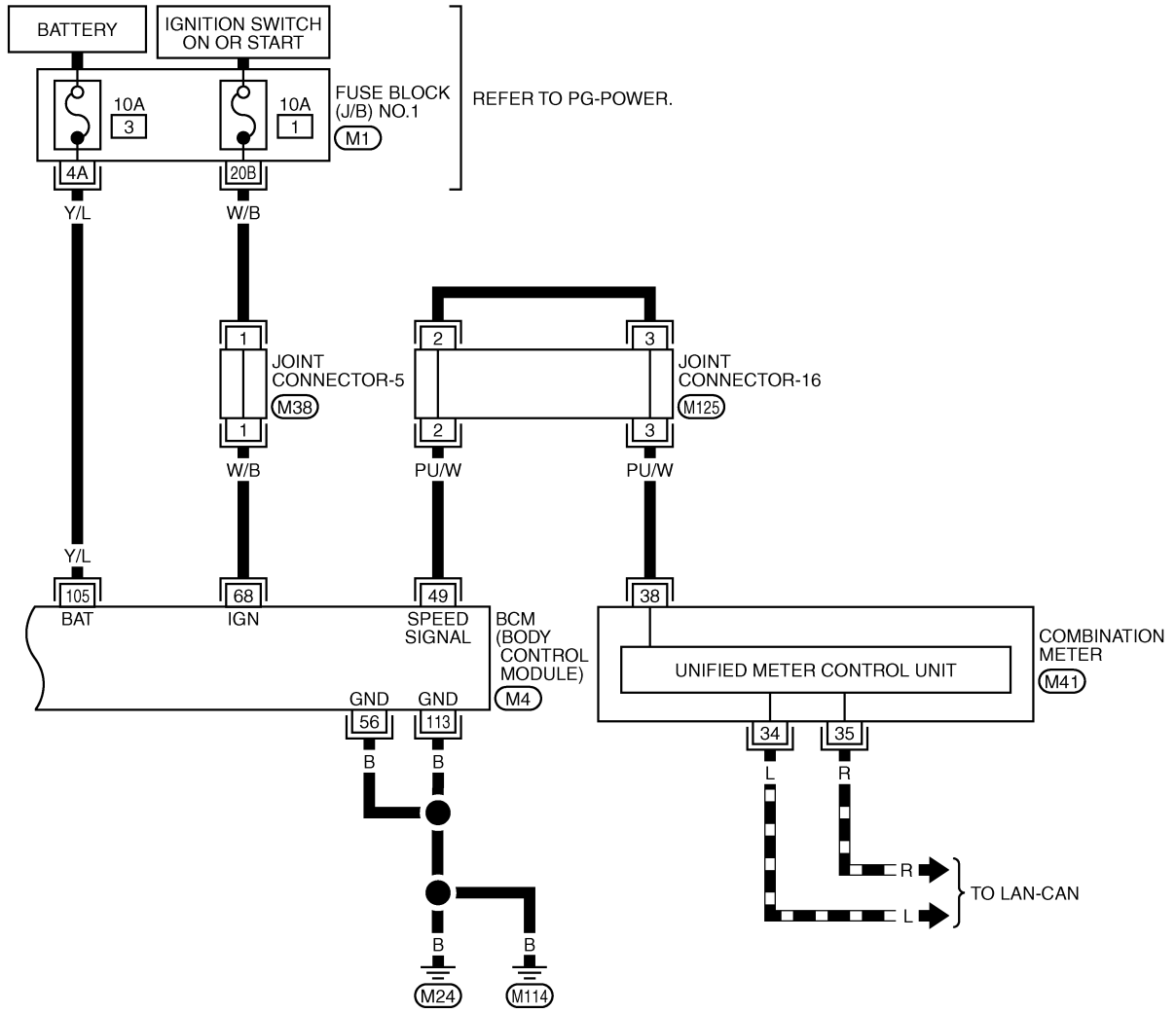

REFER TO THE FOLLOWING.

(M1) - FUSE BLOCK-JUNCTION BOX (J/B) NO.1

(M4) - ELECTRICAL UNITS

TKWA0629E

FRONT WIPER AND WASHER SYSTEM

Terminal and Reference Values for BCM

AKS002LC

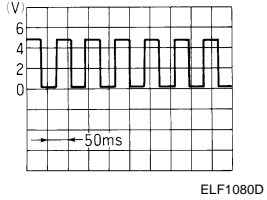
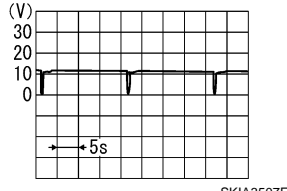
| TER-MINAL | WIRE COLOR | ITEM | CONDITION | | DATA (DC) | |
|-----------|------------|----------------------------------|------------------|--|---|-------------|
| | | | IGNI-TION SWITCH | CONDITION OR OPERATION | | |
| 4 | P | Washer switch signal | ON | Wiper switch | WASH | Approx. 0 |
| | | | | | OFF | Approx. 12 |
| 9 | OR | Wiper switch INT signal | ON | Wiper switch | INT | Approx. 0 |
| | | | | | OFF | Approx. 8 |
| 48 | R/G | Intermittent wiper volume signal | ON | Wiper intermittent interval | Long | Approx. 3.6 |
| | | | | | Short | Approx. 0 |
| 49 | PU/W | Vehicle speed signal (2-pulse) | ON | Vehicle speed approx. 40 km/h (25 MPH) |  | |
| 56 | B | Ground | ON | - | Approx. 0 | |
| 68 | W/B | Ignition on signal | ON | - | Approx. 12 | |
| 105 | Y/L | Battery Power supply | OFF | - | Approx. 12 | |
| 113 | B | Ground | ON | - | Approx. 0 | |
| 124 | SB | Wiper auto stop signal | ON | Wiper is moving | Approx. 0 | |
| | | | | Wiper while the vehicle is stopped | Approx. 12 | |
| 128 | R/Y | Wiper motor operation signal | ON | Wiper switch: INT position |  | |

Work Flow

AKS002LD

1. Confirm the symptom or customer complaint.
2. Understand the system description. Refer to [WW-4, "System Description"](#) .
3. Perform preliminary inspection. Refer to [WW-11, "Preliminary Inspection"](#) .
4. According to the trouble diagnosis chart, repair or replace the cause of the malfunction.
5. Does wiper function operate normally? If it operates normally, GO TO 6. If not, GO TO 4.
6. End

FRONT WIPER AND WASHER SYSTEM

AKS002LE

Preliminary Inspection SETTING CHANGE FUNCTIONS

- With CONSULT-II, each function can be changed in setting. Refer to [WW-13, "WORK SUPPORT"](#).

CAUTION:

After the setting was changed, the new setting will be maintained even if the battery was disconnected.

| Setting change mode | CONSULT-II (WORK SUPPORT) | Description |
|---|------------------------------|--------------|
| Wiper intermittent speed control by vehicle speed | ON | Activated |
| | OFF | Disactivated |

INSPECTION FOR POWER SUPPLY AND GROUND CIRCUIT

Inspection procedure

1. CHECK FUSE

- Make sure wiper and washer fuse is blown.

| Unit | Power source | Fuse No. |
|--|----------------------|----------|
| Front wiper motor, Front washer motor, Front wiper relay | Ignition ON or START | 34 |

CAUTION:

For fuse number, refer to [WW-5, "Component Parts and Harness Connector Location"](#).

OK or NG

OK >> GO TO 2.

NG >> If fuse is blown, be sure to eliminate cause of malfunction before installing new fuse. Refer to [PG-2, "POWER SUPPLY ROUTING"](#).

2. CHECK POWER SUPPLY CIRCUIT

- Disconnect the connector of front wiper motor, front washer motor and front wiper relay.
- Check voltage between the following connector terminals and ground.

| Unit (Connector) | Terminals (wire color) | | Ignition switch condition | Voltage |
|--------------------------|------------------------|--------|---------------------------|-----------------|
| | (+) | (-) | | |
| Front wiper motor (E75) | 4 (LG) | Ground | ON | Battery voltage |
| Front washer motor (E48) | 1 (LG) | | | |
| Front wiper relay (E2-2) | 1 (LG) | | | |

OK or NG

OK >> GO TO 3.

NG >> Replace harness of wiper and washer power supply circuit.

3. CHECK GROUND CIRCUIT (BCM)

Check for continuity between the following BCM connector terminals and ground.

| Unit (Connector) | Terminals (wire color) | | Ignition switch condition | Continuity |
|------------------|------------------------|--------|---------------------------|-------------------------|
| | (+) | (-) | | |
| BCM (M4) | 56 (B) | Ground | OFF | Continuity should exist |
| | 113 (B) | | | |

OK or NG

OK >> Inspection end

NG >> Replace the harness BCM ground circuit.

FRONT WIPER AND WASHER SYSTEM

AKS002LF

CONSULT-II Function

- CONSULT-II executes the following functions by combining data received and command transmitted via the communication line from the BCM. IVMS communication inspection, work support by part, self-diagnosis, data monitor, and active test display.

| IVMS diagnosis part | Check item and diagnosis mode | Description |
|---------------------|-------------------------------|---|
| WIPER | WORK SUPPORT | Changes the setting for each function. |
| | DATA MONITOR | Displays data relative to BCM input signals and various control related data for each system. |
| | ACTIVE TEST | Gives a drive signal to a load to check the operation. |
| BCM PART NUMBER. | | Displays BCM part No. |

CONSULT-II BASIC OPERATION PROCEDURE

- With the ignition switch OFF, connect CONSULT-II and CONSULT-II CONVERTER to the data link connector, then turn ignition switch ON.

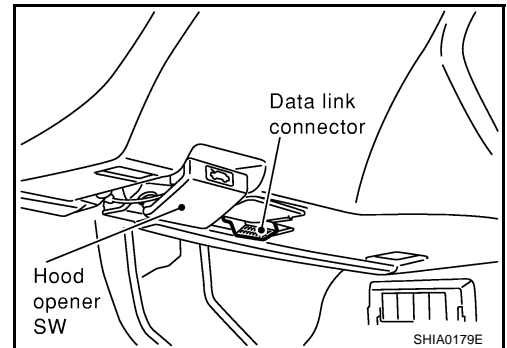

- Touch "START (NISSAN BASED VHCL)".

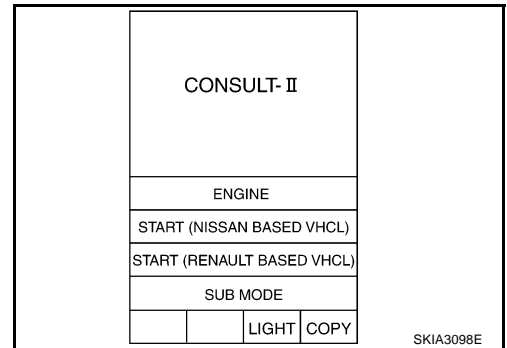

- Touch "IVMS" on "SELECT SYSTEM" screen. If "IVMS" is not indicated, go to [GI-38, "CONSULT-II Data Link Connector \(DLC\) Circuit"](#).

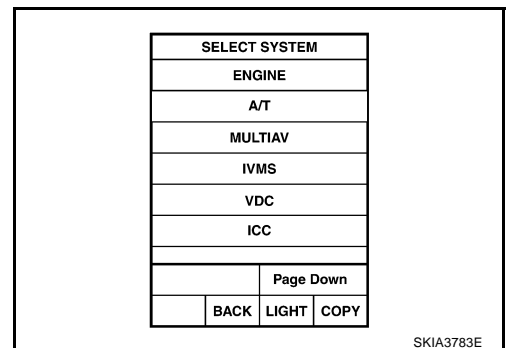

FRONT WIPER AND WASHER SYSTEM

- Check the model specification, touch either "WITH SUNROOF" or "WITHOUT SUNROOF".
- Touch "OK". If the selection is wrong, touch "CANCEL".

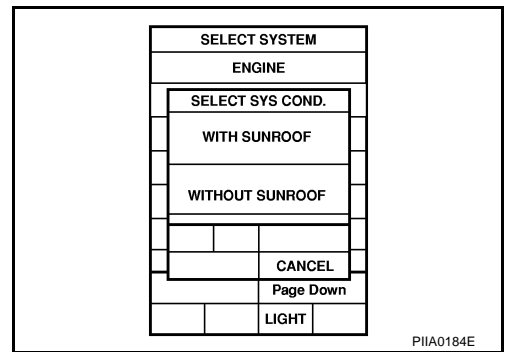

- Select the desired part to be diagnosed on the "SELECT TEST ITEM" screen.

WORK SUPPORT

Operation Procedure

- Touch "WIPER" on the "SELECT TEST ITEM" screen.
- Touch "WORK SUPPORT" on the "SELECT DIAG MODE" screen.
- Touch "WIP INT VHCL SPD ADJ" on the "SELECT WORK ITEM" screen.
- Touch "START".
 - Wiper intermittent speed control by vehicle speed can be canceled or resumed.
- Touch "CURRENT SETTING" for changing "CURRENT SETTING". For no changing "CURRENT SETTING", touch "END".

| "CURRENT SETTING" | Wiper intermittent speed control |
|-------------------|----------------------------------|
| "ON" | Activated |
| "OFF" | Disactivated |

- Touch "END" after customizing is completed.

DATA MONITOR

Operation Procedure

- Touch "WIPER" on the "SELECT TEST ITEM" screen.
- Touch "DATA MONITOR" on the "SELECT DIAG MODE" screen.
- Touch either "ALL SIGNALS" or "SELECTION FROM MENU" on the "DATA MONITOR" screen.
- Touch "START".

Date Monitor Item

| Monitored item | Description |
|----------------|---|
| IGN ON SW | Indicates "IGN [ON] / ACC or OFF [OFF]" condition of ignition switch signal. |
| INT SW | Indicates " INT Position [ON] / Others [OFF]" condition of wiper switch signal. |
| WASH SW | Indicates "WASH Position [ON] / Others [OFF]" condition of wiper switch signal. |
| VHCL SPEED SE | Indicates "Vehicle is moving [RUN] / Vehicle Stopped [STOP]" condition of vehicle speed signal. |
| WIPR AUTO STP | Indicates "INT or OFF Position [IGN] / LO or HI Position [OFF]" condition of wiper switch signal. |
| INTRESIST | Indicates " Intermittent Resistance Value [approx. 0 to 1]" condition wiper switch signal. |

ACTIVE TEST

Operation Procedure

- Touch "WIPER" on the "SELECT TEST ITEM" screen.
- Touch "ACTIVE TEST" on the "SELECT DIAG MODE" screen.
- Touch the item to be tested, and check the operation.

| Test item "WIPER AMP" | Wiper motor operation |
|-----------------------|-----------------------|
| "ON" | Operate |
| "OFF" | Stop |

FRONT WIPER AND WASHER SYSTEM

4. During the operation check, touching "OFF" deactivates the operation.

On Board Diagnosis

AKS002LG

- IVMS can check communication diagnosis, switch monitor, and power door lock system self-diagnosis using on board diagnosis.
- Map lamps and step lamps (all seats) act as the indicators for the on board diagnosis.

DIAGNOSIS ITEM FOR FRONT WIPER AND WASHER SYSTEM

| Diagnosis item | Description |
|----------------|---------------------------------------|
| Switch monitor | It can check wiper and washer switch. |

SWITCH MONITOR

How to Perform Switch Monitor

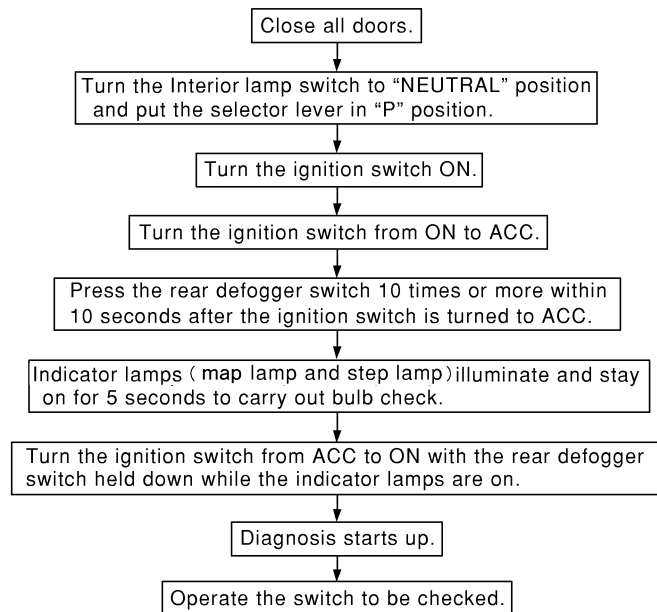
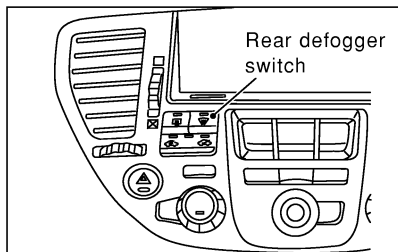
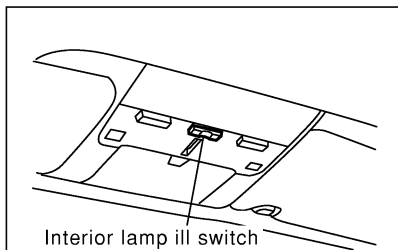

SIA0411E

Diagnosis Result Display

- Detects the status change (switch ON/OFF operation) of the switch to be checked, and turns on/off the indicator lamps (the map lamp and step lamp). Also sounds the buzzer for 0.5 seconds.
- If a malfunction is detected, no indicator lamp and buzzer react.

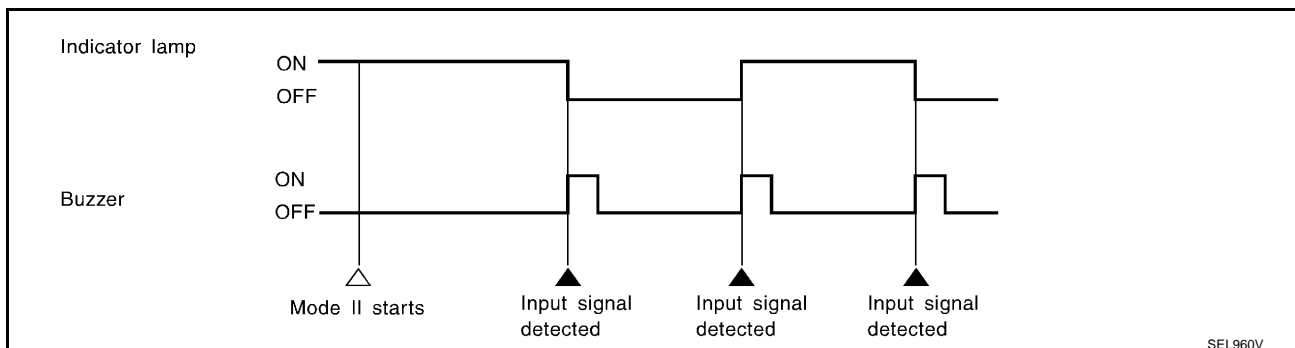

SEL960V

Cancel of Switch Monitor

- Turn ignition switch OFF.
- Drive the vehicle at more than 7 km/h (4MPH).

FRONT WIPER AND WASHER SYSTEM

AKS002LH

Intermittent Wiper Does Not Operate

1. CHECK INTERMITTENT WIPER SWITCH INPUT SIGNAL

 With CONSULT-II
See "INT SW" in DATA MONITOR mode.
When wiper switch is in INT position: ON
When wiper switch is in OFF position: OFF

NOTE:
When "DATA MONITOR" is operating, intermittent wiper does not operate.

 Without CONSULT-II
Check wiper switch (INT) in switch monitor mode. Refer to [WW-14](#), "[SWITCH MONITOR](#)".

OK or NG

- OK >> GO TO 2
NG >> Check the following.
- Front wiper switch
 - Harness for open or short between BCM and wiper switch
 - Front wiper switch ground circuit

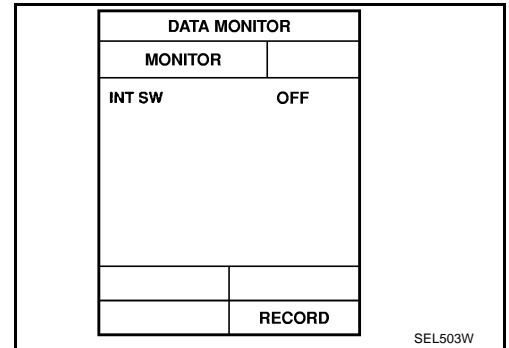

2. CHECK WIPER AUTO STOP SIGNAL

 With CONSULT-II
See "WIP AUTO STOP" in DATA MONITOR mode, and turn wiper switch to LO or HI position.
When wiper switch is in INT or OFF position: IGN
When wiper switch is in LO or HI: GND

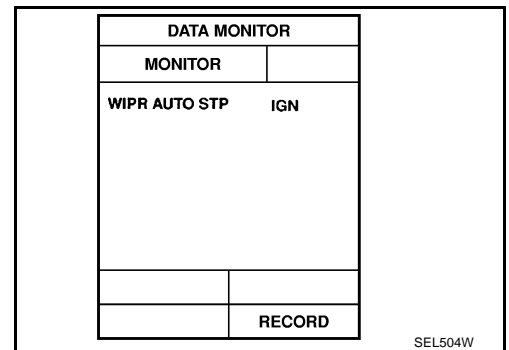

-  Without CONSULT-II
1. Turn ignition switch ON.
 2. Turn wiper switch to LO or HI position.
 3. Check voltage between BCM harness connector E204 terminal 124 (SB) and ground.

Wiper is moving : Approx. 0V
Wiper is stopped : Approx. 12V

OK or NG

- OK >> GO TO 3
NG >> Check the following.
- Wiper motor
 - Wiper motor ground circuit
 - Harness for open or short between BCM and wiper motor

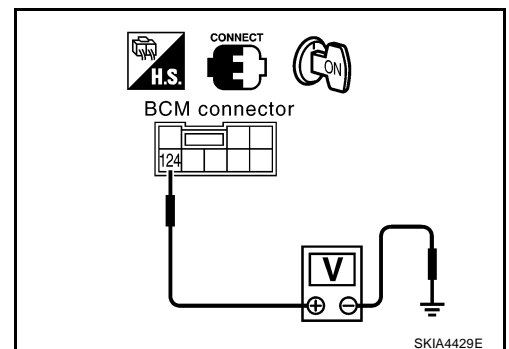

A
B
C
D
E
F
G
H
I
J
K
L
M

WW

FRONT WIPER AND WASHER SYSTEM

3. CHECK IGNITION SWITCH ON SIGNAL

 With CONSULT-II
See "IGN ON SW" in DATA MONITOR mode.
When ignition switch is ON: ON
When ignition switch is ACC or OFF: OFF

| DATA MONITOR | |
|--------------|----|
| MONITOR | |
| IGN ON SW | ON |
| | |
| | |
| RECORD | |

PKIA0311E

 Without CONSULT-II
Check voltage between BCM harness connector M4 terminal 68 (W/B) and ground.

**Ignition switch is ON : Approx. 12V
or start**

**Ignition switch is ACC : Approx. 0V
or OFF**

OK or NG

OK >> GO TO 4

NG >> Check the following.

- 10A fuse [No. 1, located in the fuse block (J/B) No.1]
- Harness for open or short between fuse and BCM

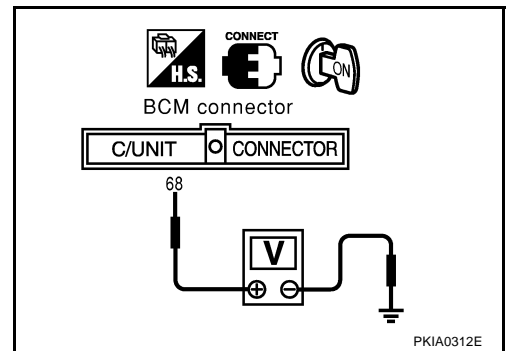

4. CHECK WIPER OPERATION

 With CONSULT-II
See "WIPER AMP" in ACTIVE TEST mode. Perform operation shown on display.

Wiper motor should operate.

NOTE:

If CONSULT-II is not available, skip this procedure and go to [WW-19, "Wiper And Washer Activate Individually But Intermittent Wiper And Washer Combination Does Not Operate"](#) .

OK or NG

OK >> Replace BCM.

NG >> GO TO [WW-19, "Wiper And Washer Activate Individually But Intermittent Wiper And Washer Combination Does Not Operate"](#)

| ACTIVE TEST | |
|-------------|-----|
| WIPER AMP | OFF |
| | |
| | |
| ON | |

SEL494W

FRONT WIPER AND WASHER SYSTEM

Intermittent Time Of Wiper Cannot Be Adjusted

AKS002LI

1. CHECK INTERMITTENT WIPER VOLUME INPUT SIGNAL

 With CONSULT-II
See "INT RESIST" in DATA MONITOR mode while turning intermittent wiper volume.

Short interval : Approx. 0Ω

Long interval : Approx. 1Ω

| DATA MONITOR | |
|--------------|----------|
| MONITOR | |
| INT RESIST | XXX kohm |
| RECORD | |

SEL506W

 Without CONSULT-II

1. Disconnect BCM connector.
2. Measure resistance between BCM harness connector M4 terminal 48 (R/G) and ground while turning intermittent wiper volume.

Short interval : Approx. 0Ω

Long interval : Approx. 1Ω

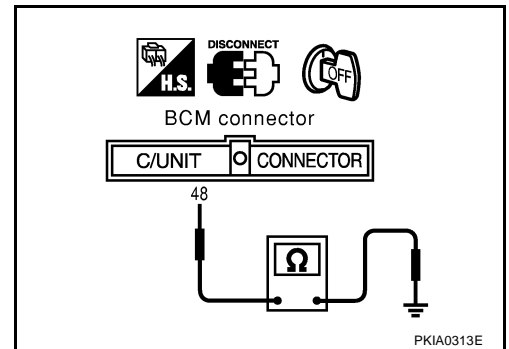

OK or NG

OK >> Replace BCM.

NG >> GO TO 2

2. CHECK FRONT WIPER SWITCH

Check front wiper switch. Refer to [WW-20, "Wiper and Washer Switch Circuit Check"](#).

OK or NG

OK >> Check the following.

- Harness for open or short between BCM and front wiper switch
- front wiper switch ground circuit

NG >> Replace front wiper switch

Wiper And Washer Activate Individually But Not In Combination

AKS002LJ

1. CHECK WASHER SWITCH INPUT SIGNAL

 With CONSULT-II
See "WASH SW" in DATA MONITOR mode.
When washer switch is ON: ON
When washer switch is OFF: OFF

 Without CONSULT-II
Check wiper switch (WASH) in switch monitor mode. Refer to [WW-14, "SWITCH MONITOR"](#).

OK or NG

OK >> Replace BCM.

NG >> Check the following.

- Harness for open or short between BCM and front wiper switch

| DATA MONITOR | |
|--------------|-----|
| MONITOR | |
| WASH SW | OFF |
| RECORD | |

SEL507W

FRONT WIPER AND WASHER SYSTEM

Intermittent Wiper Operates, But There Is No Change In Intermittent Time Between When Vehicle Is Stopped And Moving

AKS002LK

1. CHECK THE SYMPTOM

Check that the speedometer in the combination meter operates normally.

OK or NG?

OK >> GO TO 2

NG >> Check vehicle speed signal. Refer to "Work Flow" in DI section.

2. CHECK VEHICLE SPEED SENSOR PULL UP VOLTAGE

① With CONSULT-II

- With "VHCL SPEED SE" on the DATA MONITOR, check the vehicle speed signal. Refer to [SE-44, "DATA MONITOR"](#)

② Without CONSULT-II

- Go to 3

OK or NG

OK >> System is OK.

NG >> GO TO 3.

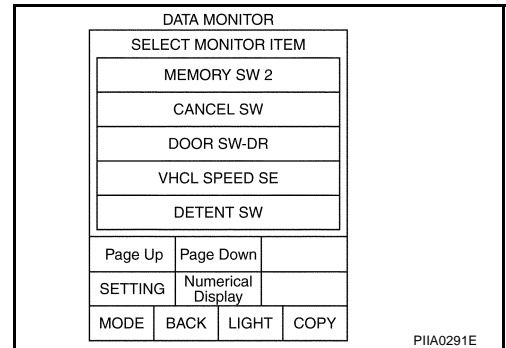

3. VEHICLE SPEED INPUT/OUTPUT INSPECTION

- Start the engine, and check the voltage between terminal No. 49 (PU/W) on the harness connector M4 for the BCM and body ground, using an oscilloscope.

No.49 (PU/W)-body ground

: Voltage waveform (When vehicle speed is approx. 40km/h (25MPH))

OK or NG?

OK >> Replace the BCM.

NG >> GO TO 4.

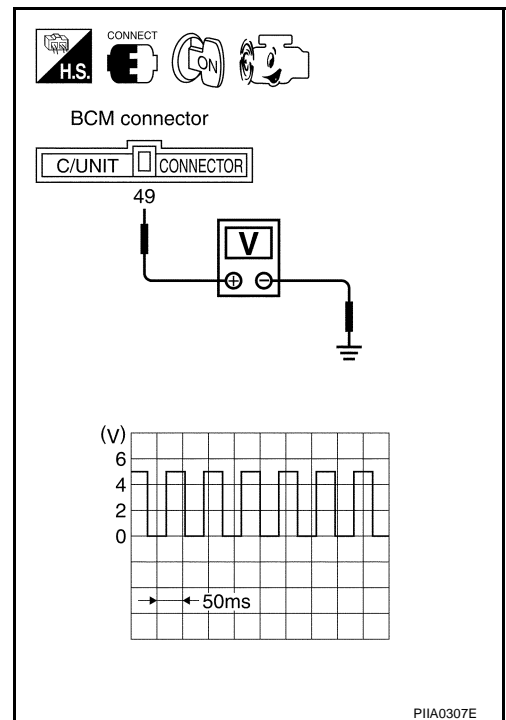

FRONT WIPER AND WASHER SYSTEM

4. HARNESS CONTINUITY INSPECTION

- Turn the ignition switch OFF, and disconnect the connectors M4, M41 for the BCM and combination meter.
- Check the continuity between terminal No.49 (PU/W) on the harness connector M4 for the BCM and terminal No.38 (PU/W) on the harness connector M41 for the combination meter, and between terminal No. 49 (PU/W) on the harness connector M4 for the BCM and body ground.

| Terminals | | | | Continuity |
|-----------|-----------|-----------|-----------|------------------|
| (+) | | (-) | | |
| Connector | Terminal | Connector | Terminal | |
| M4 | 49 (PU/W) | M41 | 38 (PU/W) | Should exist |
| | 49 (PU/W) | Ground | | Should not exist |

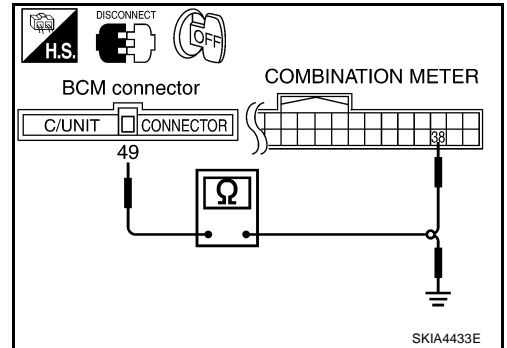

OK or NG?

- OK >> Replace the meter control unit.
- NG >> Repair or replace harness.

Wiper And Washer Activate Individually But Intermittent Wiper And Washer Combination Does Not Operate

AKS002LL

1. CHECK POWER SUPPLY CIRCUIT FOR FRONT WIPER RELAY

1. Remove front wiper relay.
2. Turn ignition switch to ON position.
3. Check voltage between front wiper relay harness connector E2-2 terminal 1 (LG) and ground.

Battery voltage should exist.

OK or NG

- OK >> GO TO 2
- NG >> Check the following.
 - 20A fuse [No. 34, located in the fuse block (J/B) No.2]
 - Harness for open or short between front wiper relay and fuse.

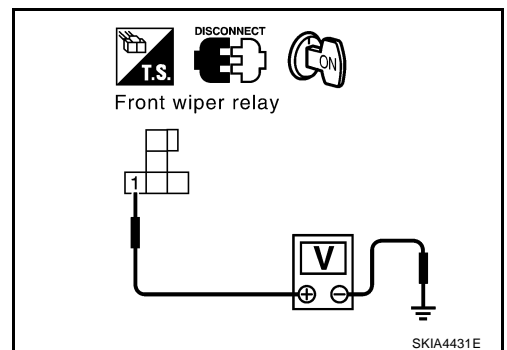

2. CHECK GROUND CIRCUIT FOR FRONT WIPER RELAY

1. Turn ignition switch OFF.
2. Check continuity between front wiper relay harness connector E2-2 terminal 5 (B) and ground.

Continuity should exist.

OK or NG

- OK >> GO TO 3
- NG >> Repair harness.

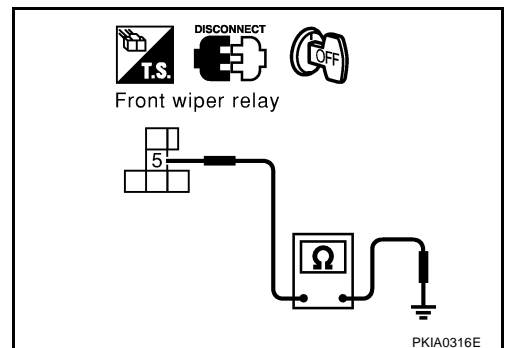

FRONT WIPER AND WASHER SYSTEM

3. CHECK FRONT WIPER RELAY

Check front wiper relay.

OK or NG

- OK >> GO TO 4
- NG >> Replace front wiper relay.

4. CHECK BCM OUTPUT SIGNAL

1. Connect front wiper relay.
2. Turn ignition switch ON.
3. Check voltage between BCM harness connector E204 terminal 128 (R/Y) and ground.

Wash : 0 (for 0.7 sec.) V
OFF : Approx. 12V

OK or NG

- OK >> Repair harness between BCM and front wiper relay.
- NG >> Replace BCM.

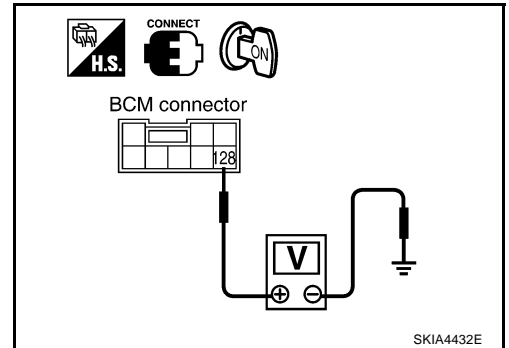

Wiper and Washer Switch Circuit Check INSPECTION OF SWITCH CIRCUIT

Check continuity between each terminal when wiper washer switch is operating using a circuit tester.

| Operation interval (intermittent wiper with vehicle speed detection function) | Resistance value (kΩ) |
|---|-----------------------|
| 1, interval (Max.) | 0.964 |
| 2, | 0.659 |
| 3, | 0.325 |
| 4, interval (Min.) | 0.008 |

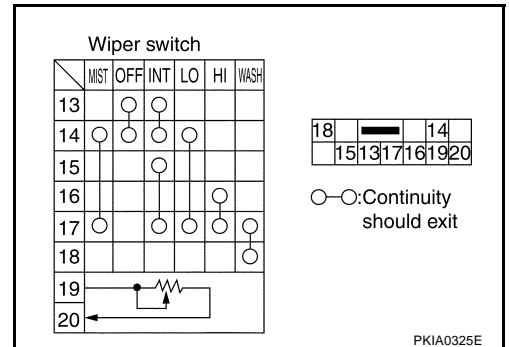

Removal and Installation for Front Wiper Arms, Adjustment for Wiper Arms Stop Location REMOVAL

1. Operate wiper motor, and stop it at the auto stop position.
2. Remove wiper arm mounting nuts and wiper arm from vehicle.

INSTALLATION

1. Clean up the pivot area as illustrated. This will reduce possibility of wiper arm looseness.

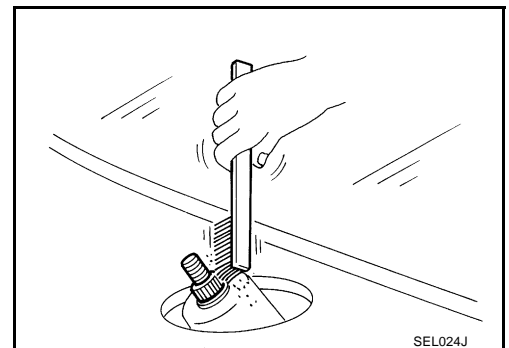

FRONT WIPER AND WASHER SYSTEM

2. Prior to wiper arm installation, turn on wiper switch to operate wiper motor and then turn it "OFF" (auto stop).
3. Push wiper arm onto pivot shaft, paying attention to blind spline.
4. Lift the blade up and then set it down onto glass surface to set the blade center to clearance "L1" & "L2" immediately before tightening nut.
5. Eject washer fluid. Turn on wiper switch to operate wiper motor and then turn it "OFF".
6. Ensure that wiper blades stop within clearance "L1" & "L2".

Clearance "L1" : 44.1 - 59.1 mm (1.74 - 2.33 in)

Clearance "L2" : 30.9 - 45.9 mm (1.22 - 1.81 in)

- Tighten wiper arm nuts to the specified torque.

Front wiper arm mounting nuts  : **20.6 - 26.5 N·m**
(2.1 - 2.7 kg-m, 16 - 19 ft-lb)

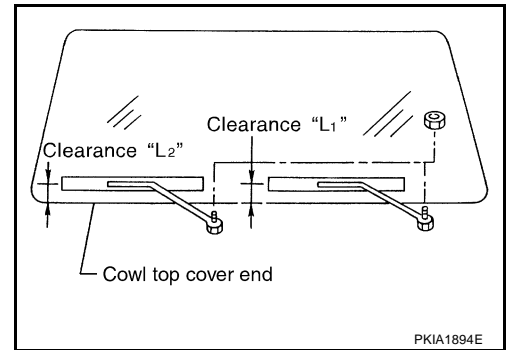

A
B
C
D
E
F
G
H
I
J
L
M

ADJUSTMENT

Refer to [WW-20, "INSTALLATION"](#).

Removal and Installation of Front Wiper Motor and Linkage

REMOVAL

1. Remove wiper arm. Refer to [WW-20, "Removal and Installation for Front Wiper Arms, Adjustment for Wiper Arms Stop Location"](#).
2. Remove cowl top cover. Refer to [EI-20, "COWL TOP"](#) in "EI" section.
3. Disconnect wiper motor connector.
4. Remove wiper motor and linkage mounting bolts, and remove wiper motor and linkage.

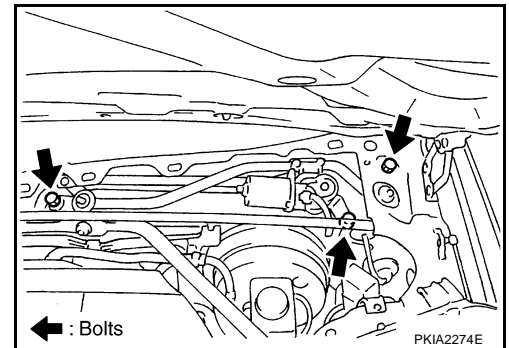

AKS003WE

INSTALLATION

1. Install wiper motor and linkage to the vehicle.
2. Connect wiper motor assembly to the connector. Turn wiper switch ON to operate wiper motor, then turn wiper switch OFF (auto stop).
3. Install cowl top cover. Refer to [EI-20, "COWL TOP"](#) in "EI" section.
4. Install wiper arms. Refer to [WW-20, "Removal and Installation for Front Wiper Arms, Adjustment for Wiper Arms Stop Location"](#).

Wiper motor and linkage mounting bolts

 : **3.8 - 5.1 N·m (0.39 - 0.52 kg-m, 34 - 45 in-lb)**

CAUTION:

- Do not drop the wiper motor or cause it to contact other parts.
- Check grease conditions of the motor arm and wiper link joint (at retainer). Apply grease if necessary.

WW

FRONT WIPER AND WASHER SYSTEM

Disassembly and Assembly Front Wiper Motor and Linkage

AKS003WF

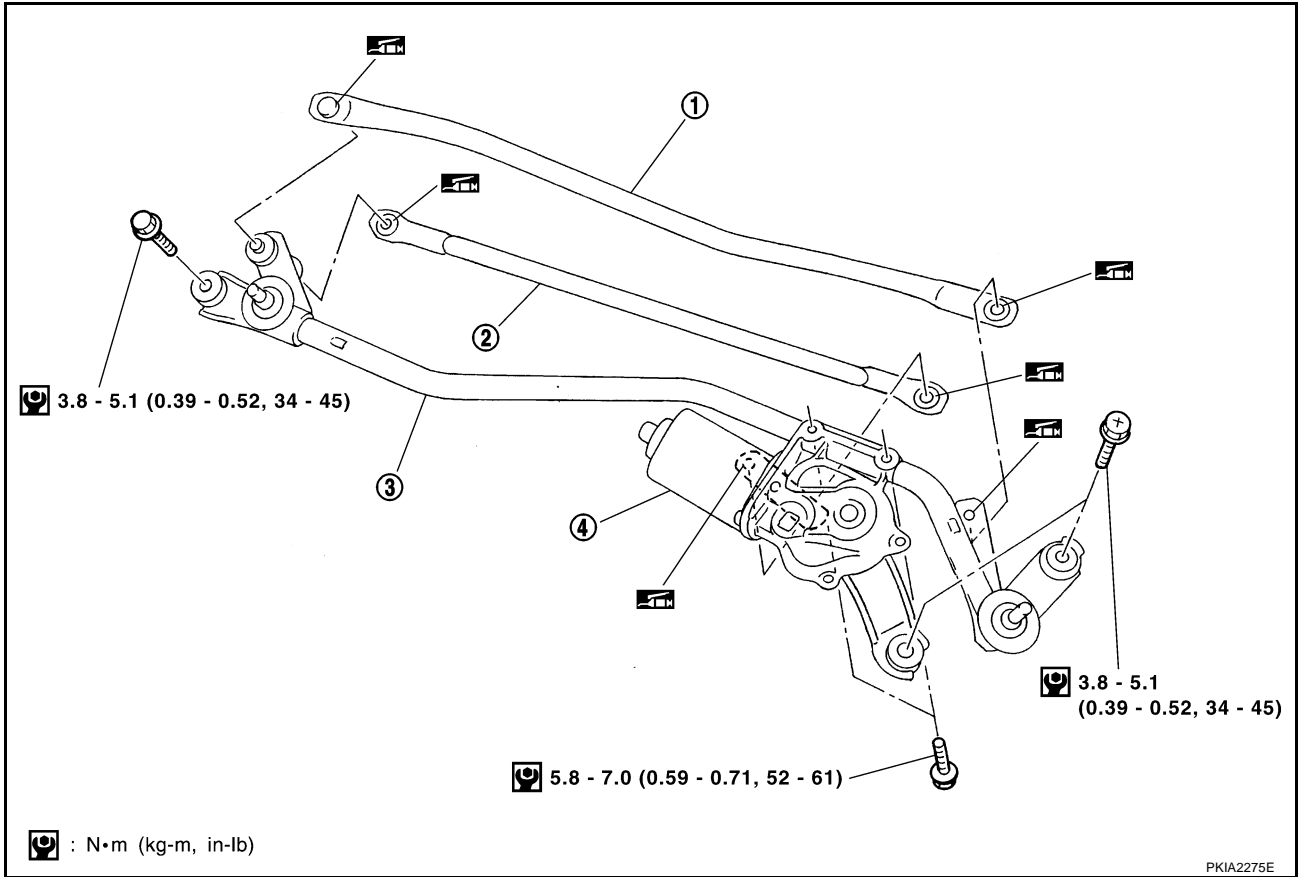

1. Wiper link 1
2. Wiper link 2
3. Wiper frame
4. Wiper motor

DISASSEMBLY

1. Remove wiper link from wiper frame and motor arm.
2. Remove wiper motor mounting bolts, and remove wiper motor from wiper frame.

ASSEMBLY

Paying attention to the work listed below, assemble in reverse order of disassembly.

Wiper motor mounting bolts:

: 5.8 - 7.0 N·m (0.59 - 0.71 kg-m, 52 - 61 in-lb)

Washer Nozzle Adjustment

AKS003WG

1. When wiper blade position is in auto stop condition, remove wiper motor connector to ensure wiper arms do not move.
2. Adjust each nozzle position so that spray positions are in the range of shaded parts.

FRONT WIPER AND WASHER SYSTEM

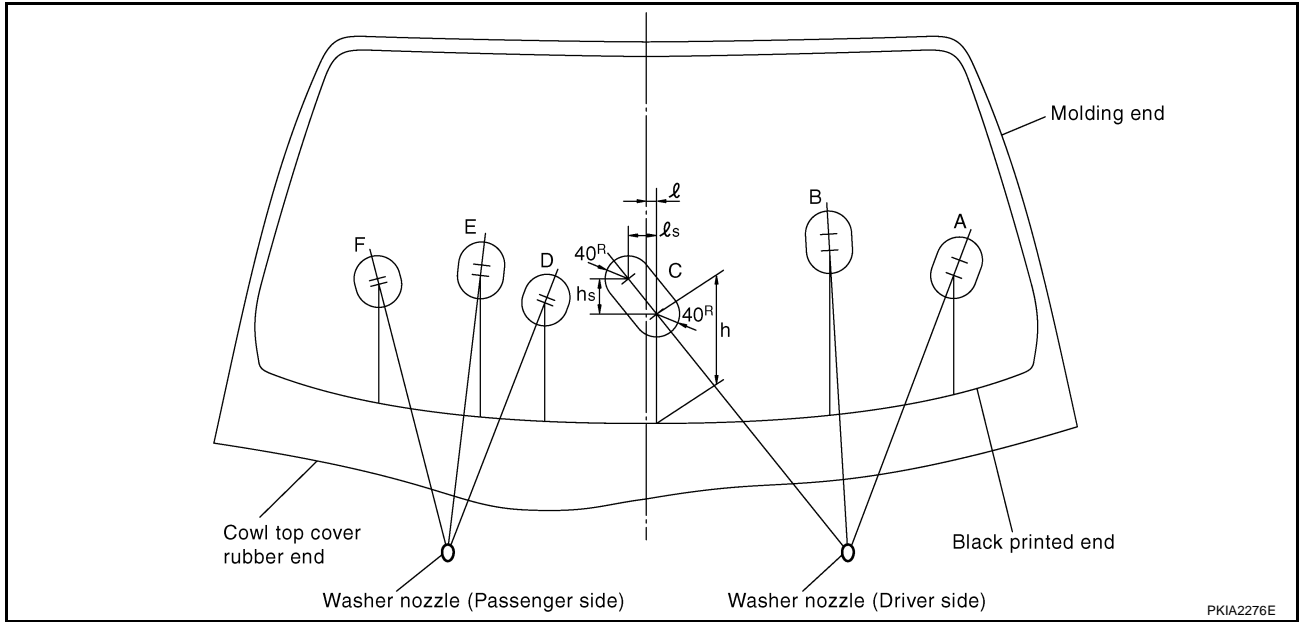

PKIA2276E

Unit: mm (in)

| Spray position | h (height) | h _s | ℓ (width) | ℓ_s |
|----------------|-------------|----------------|----------------|--------------|
| A | 212 (8.35) | 26 (1.02) | 539 (21.22) | 10.5 (0.41) |
| B | 290 (11.42) | 30 (1.18) | 319 (12.56) | -1.7 (0.07) |
| C | 192 (7.56) | 63 (2.48) | 19 (0.75) | -49.5 (1.95) |
| D | 208 (8.19) | 9.3 (0.37) | 175 (6.89) | 3.6 (0.14) |
| E | 246 (9.69) | 19.9 (0.78) | 290 (11.42) | 2.4 (0.09) |
| F | 208 (8.19) | 9.7 (0.38) | 474 (18.66) | -2.4 (0.09) |

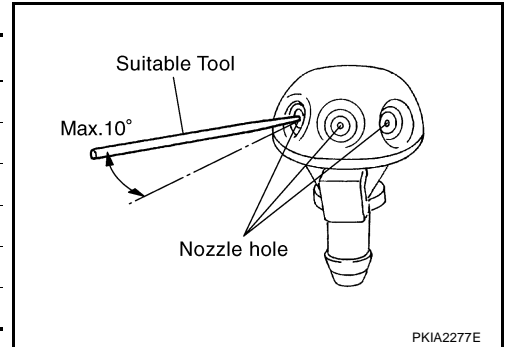

PKIA2277E

Washer Tube Layout

AKS003WH

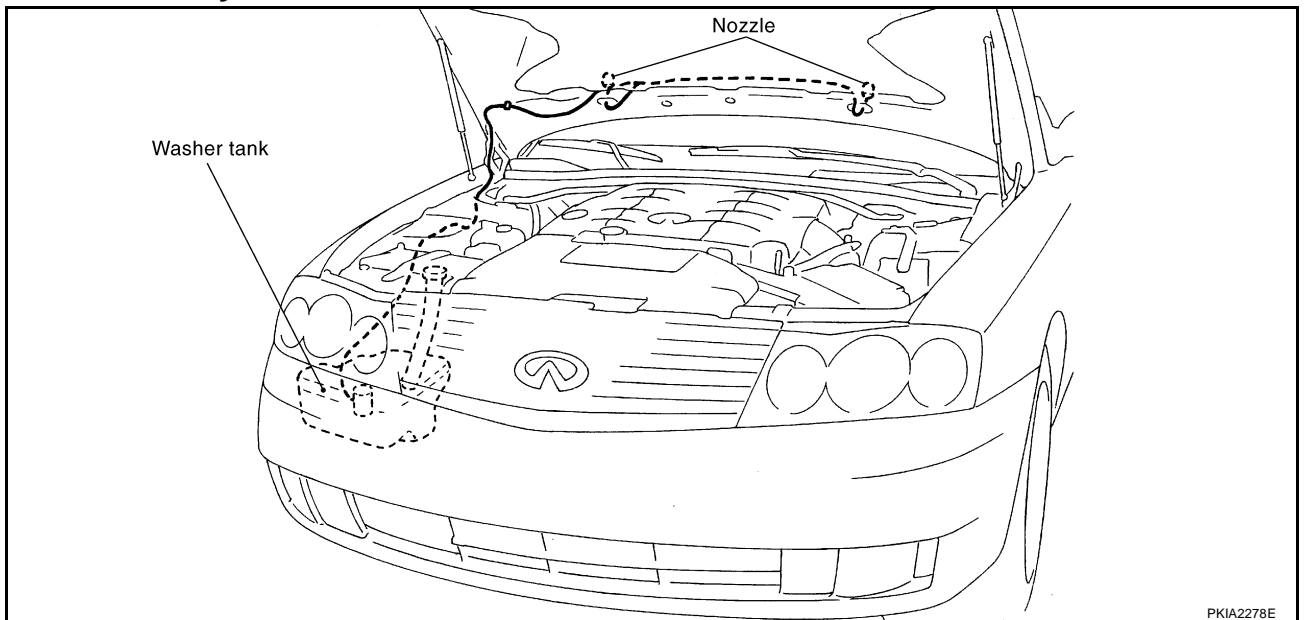

PKIA2278E

A
B
C
D
E
F
G
H
I
J
L
M

WW

FRONT WIPER AND WASHER SYSTEM

Removal and Installation for Front Washer Nozzle

AKS003WJ

REMOVAL

1. Remove upwards while pressing the pawls on reverse side.
2. Remove washer tube.

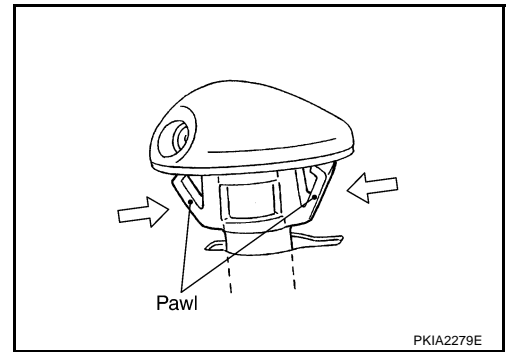

INSTALLATION

Install in the reverse order of removal.

Inspection for Washer Nozzle CHECK VALVE

AKS003WK

Blow air in the injection direction, and make sure that air flows only one way. Make sure that the reverse direction (inhale) is not possible.

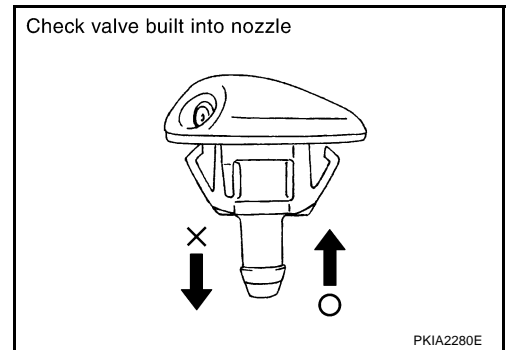

Removal and Installation for Front Wiper and Washer Switch

AKS003WL

REMOVAL

1. Remove steering column cover. Refer to [IP-11, "WORK STEPS"](#) in "IP" section.
2. Disconnect wiper and washer switch connector.
3. Pull wiper and washer switch toward the passenger door while removing screws in direction shown by the arrow in the figure, and remove it from the base.

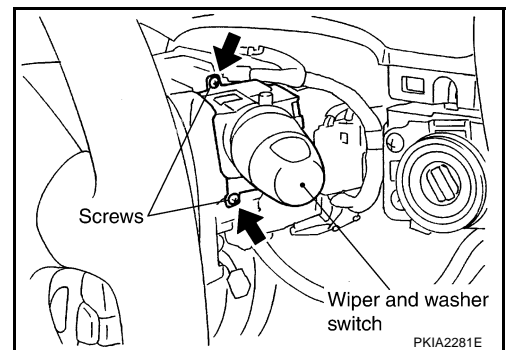

INSTALLATION

Install in the reverse order of removal.

FRONT WIPER AND WASHER SYSTEM

Removal and Installation for Washer Tank

REMOVAL

1. Remove clip and pull out washer tank inlet.

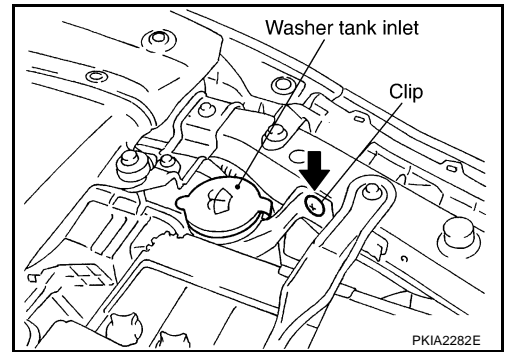

2. Remove fender protector. Refer to [EI-21, "FENDER PROTECTOR"](#) in "EI" section.
3. Disconnect washer pump and water level sensor connector.
4. Remove washer tank mounting screws and nut.
5. Remove washer tube, and remove washer tank from the vehicle.

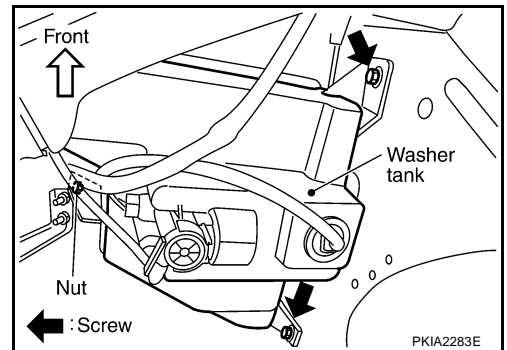

INSTALLATION

Note the following, and install in the reverse order of removal.

CAUTION:

After installation, add water up to the upper level of the washer tank inlet, and check for water leaks.

Washer tank mounting screw

 : 3.9 - 5.0 N·m (0.4 - 0.51 kg·m, 35 - 44 in·lb)

Removal and Installation for Washer Pump

REMOVAL

1. Remove fender protector. Refer to [EI-21, "FENDER PROTECTOR"](#) in "EI" section.
2. Disconnect washer pump connector and tube.
3. Pull out washer pump in direction shown by the arrow in the figure. Remove washer pump from washer tank.

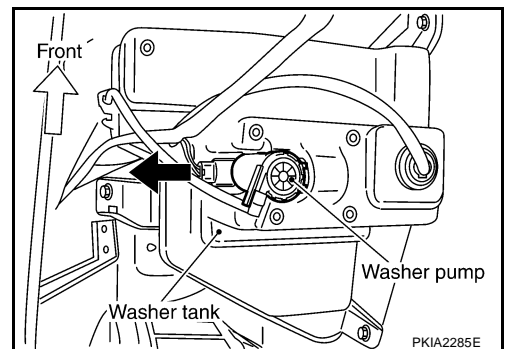

INSTALLATION

Paying attention to the following, install in the reverse order of removal.

CAUTION:

When installing washer pump, there should be no packing twists, etc.

CIGARETTE LIGHTER

PFP:35330

AKS002LW

WW-CIGAR-01

CIGARETTE LIGHTER

Wiring Diagram — CIGAR —

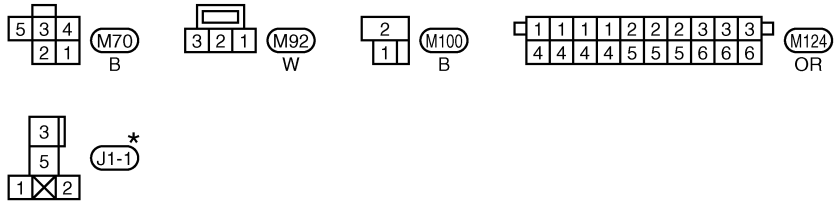
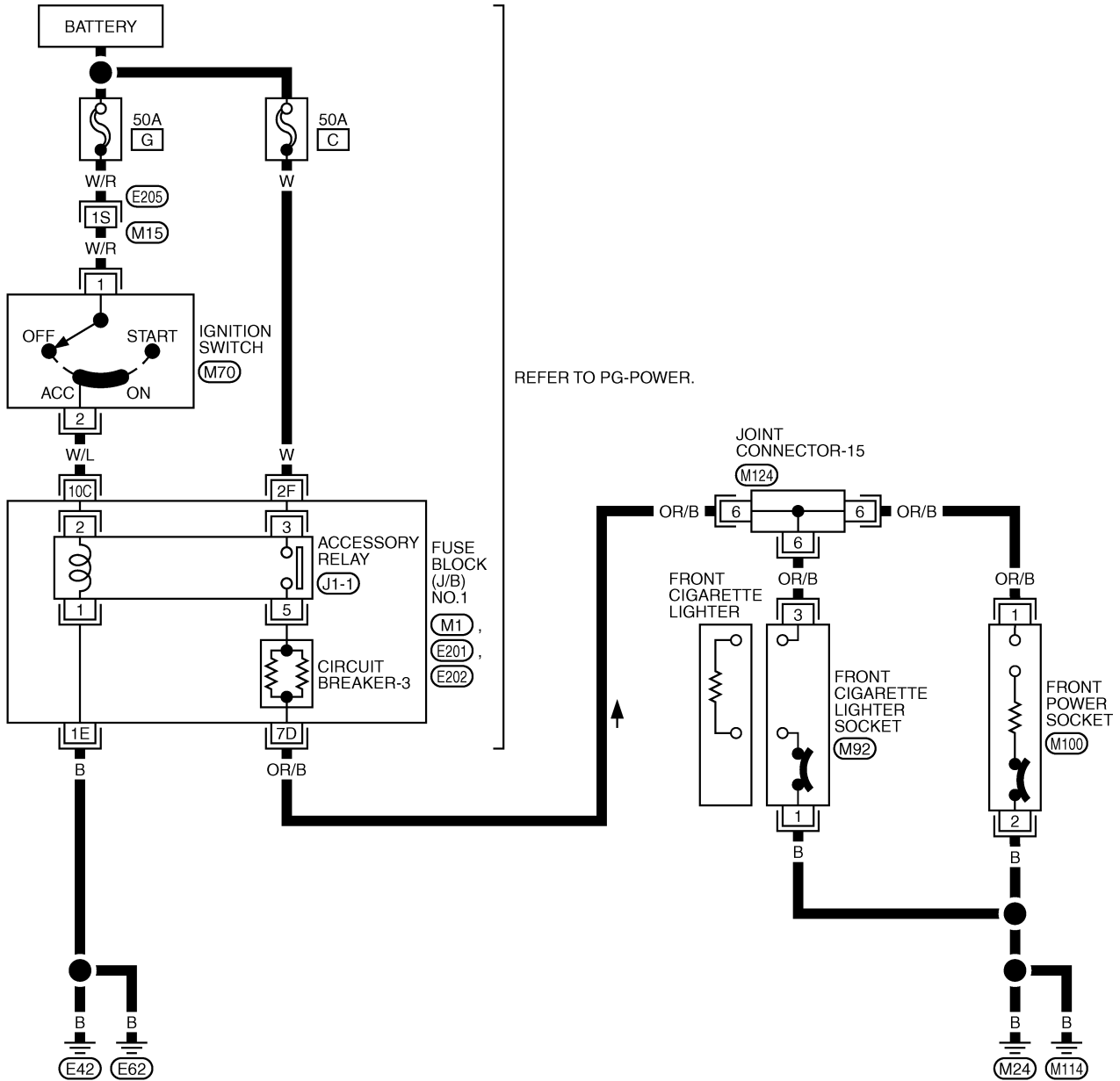

*: THIS CONNECTOR IS NOT SHOWN IN "HARNESS LAYOUT", PG SECTION.

REFER TO THE FOLLOWING.
 (E205) -SUPER MULTIPLE JUNCTION (SMJ)
 (M1), (E201), (E202) -FUSE BLOCK-JUNCTION BOX (J/B) NO.1

TKWA0631E

CIGARETTE LIGHTER

AKS002LX

Removal and Installation

REMOVAL

1. Remove A/T console finisher. Refer to [IP-11, "WORK STEPS"](#) in "IP" section.
2. Pull out cigarette lighter.
3. Remove socket from the ring, while pressing the hook on the ring out from square hole.
4. Press out ring from the back of ashtray.

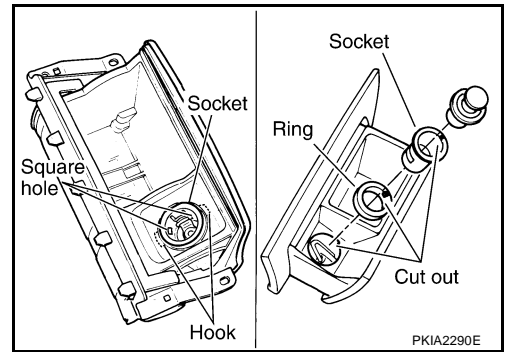

INSTALLATION

Install in the reverse order of removal.

A
B
C
D
E
F
G
H
I
J
L
M

WW

POWER SOCKET

PFP:253A2

POWER SOCKET

Wiring Diagram — CIGAR —

AKS002LY

WW-CIGAR-01

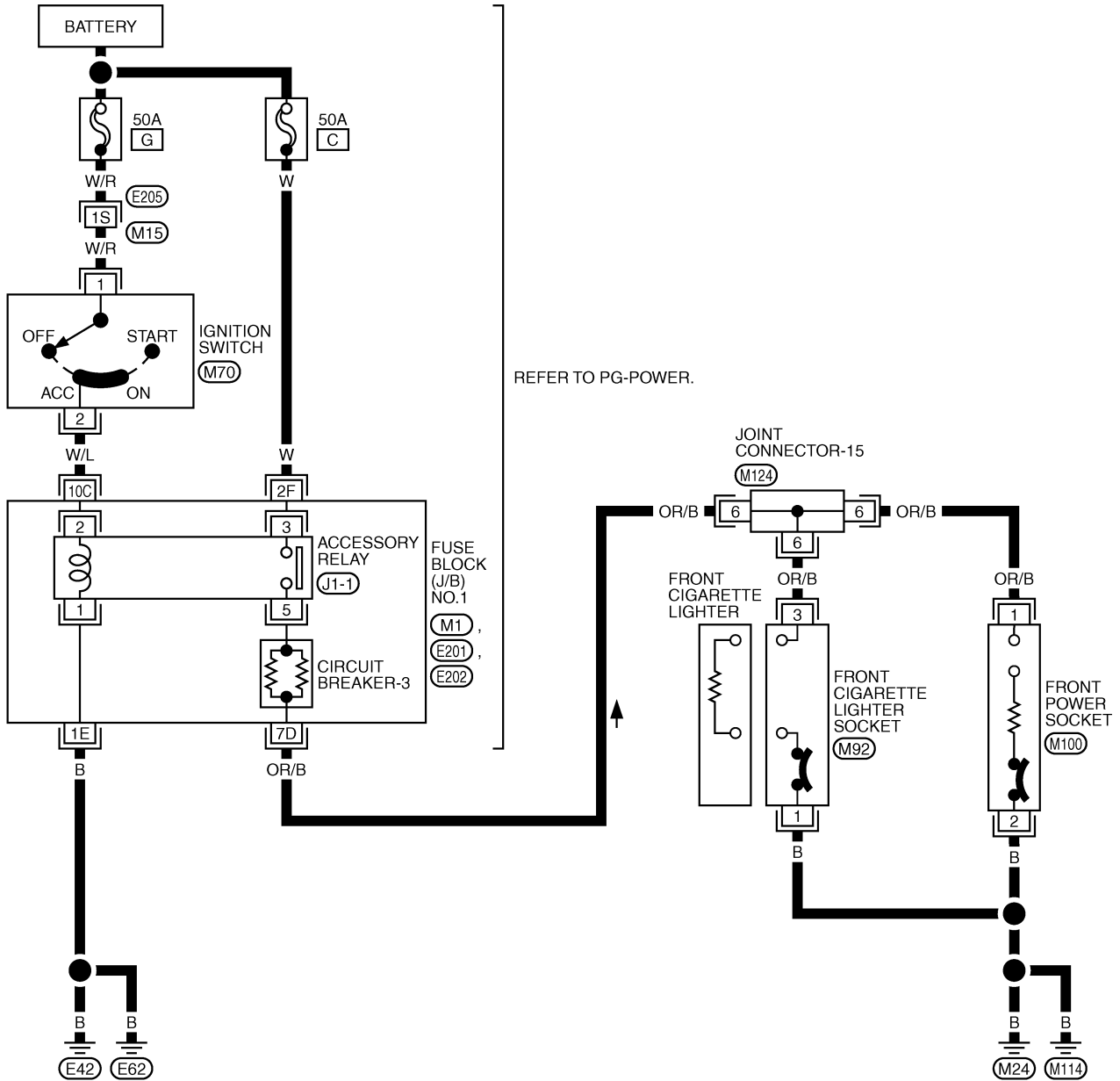

REFER TO PG-POWER.

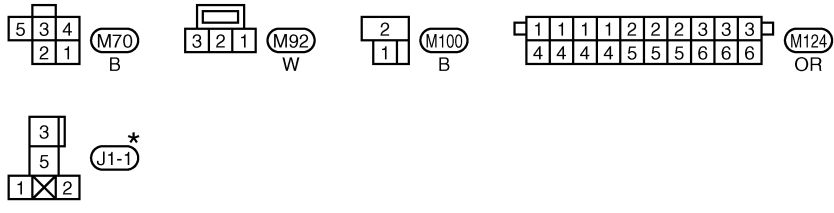

*: THIS CONNECTOR IS NOT SHOWN IN "HARNESS LAYOUT", PG SECTION.

REFER TO THE FOLLOWING.
 (E205) -SUPER MULTIPLE JUNCTION (SMJ)
 (M1), (E201), (E202) -FUSE BLOCK-JUNCTION BOX (J/B) NO.1

TKWA0631E

POWER SOCKET

Removal and Installation

REMOVAL

1. Remove console box assembly. Refer to [IP-11, "WORK STEPS"](#) in "IP" section.
2. Disconnect power socket connector.
3. Remove inner socket from the ring, while pressing the hook on the ring out from square hole.
4. Remove ring from console box while pressing pawls.

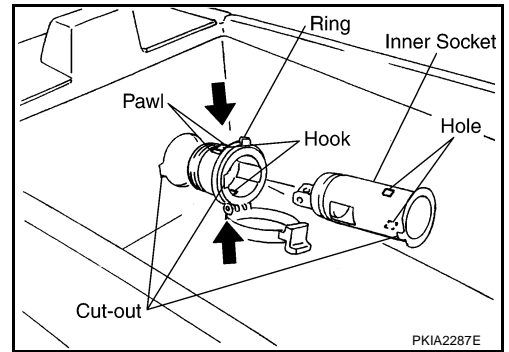

INSTALLTION

Install in the reverse order of removal.

A
B
C
D
E
F
G
H
I
J
L
M

WW

HORN

PFP:25610

HORN

Wiring Diagram — HORN —

AKS002M0

WW-HORN-01

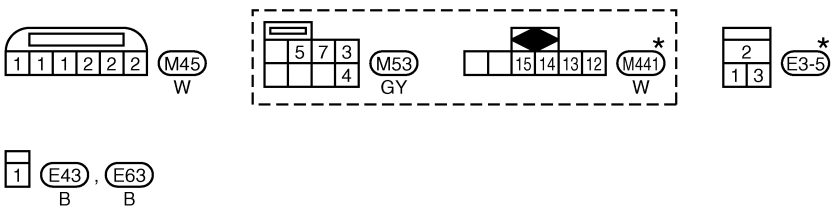
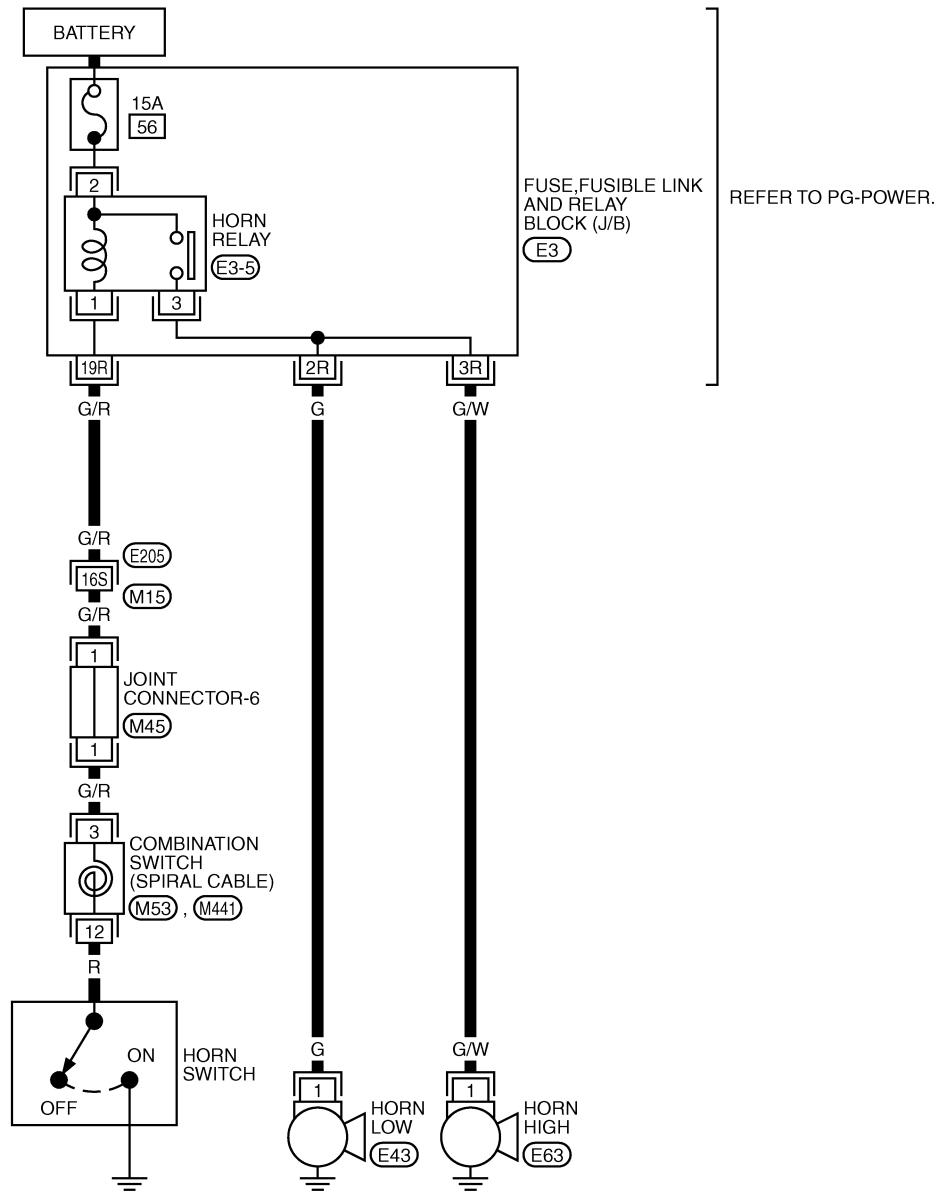

*: THIS CONNECTOR IS NOT SHOWN IN "HARNESS LAYOUT", PG SECTION.

REFER TO THE FOLLOWING.

- (E205) -SUPER MULTIPLE JUNCTION (SMJ)
- (E3) -FUSE, FUSIBLE LINK AND RELAY BLOCK (J/B)

TKWA0630E

HORN

Removal and installation

REMOVAL

1. Remove air duct. Refer to [EM-11, "ENGINE ROOM COVER"](#) in "EM" section.
2. Disconnect horn connectors.
3. Remove horn mounting bolt and remove horn from vehicle.

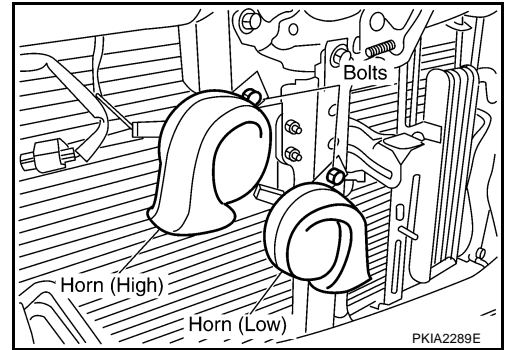

INSTALLATION

Tighten horn bolt to the specified torque.

Horn mounting bolt

 :15.7 - 18.6 N·m (1.6 - 1.8kg-m, 12 - 13ft-lb)

A
B
C
D
E
F
G
H
I
J
L
M

WW

HORN
