

SECTION **SB**
SEAT BELTS

A
B
C
D
E
F
G
SB
I
J
K
L
M

CONTENTS

| | | | |
|---|----------|--|-----------|
| PRECAUTIONS | 2 | [B2451] | 27 |
| Precautions for Supplemental Restraint System (SRS) "AIR BAG" and "SEAT BELT PRE-TENSIONER" | 2 | Brake Pedal Stroke Sensor Shield Wire Circuit Check | 28 |
| Precaution for Seat Belt Service | 2 | Removal and Installation of Pre-Crash Seat Belt Control Unit | 29 |
| AFTER A COLLISION | 2 | REMOVAL | 29 |
| PRE-CRASH SEAT BELT | 3 | INSTALLATION | 29 |
| Component Parts and Harness Connector Location... | 3 | SEAT BELTS | 30 |
| System Description | 3 | System Description | 30 |
| FUNCTION DESCRIPTION | 4 | SEAT BELT WARNING CHIME | 30 |
| FAIL-SAFE MODE | 4 | SEAT BELT WARNING LAMP | 30 |
| CAN Communication System Description | 5 | Removal and Installation of Front Seat Belt | 30 |
| CAN Communication Unit | 5 | REMOVAL OF SEAT BELT RETRACTOR | 30 |
| Schematic | 6 | INSTALLATION OF SEAT BELT RETRACTOR... .. | 31 |
| Wiring Diagram — PSB — | 7 | REMOVAL OF SEAT BELT BUCKLE | 31 |
| Terminals and Reference Value for Pre-Crash Seat Belt Control Unit | 13 | INSTALLATION OF SEAT BELT BUCKLE | 31 |
| Work Flow | 13 | Removal and Installation of Rear Seat Belt | 32 |
| CONSULT-II Function (PRECRASH SEATBELT)... .. | 14 | REMOVAL OF SEAT BELT RETRACTOR | 32 |
| CONSULT-II INSPECTION PROCEDURE | 14 | INSTALLATION OF SEAT BELT RETRACTOR... .. | 32 |
| HOW TO READ SELF-DIAGNOSTIC RESULTS.. .. | 15 | REMOVAL OF SEAT BELT BUCKLE | 32 |
| SELF-DIAGNOSTIC RESULTS ITEM CHART | 15 | INSTALLATION OF SEAT BELT BUCKLE | 33 |
| DATA MONITOR ITEM CHART | 15 | Seat Belt Inspection | 33 |
| Preliminary Check | 16 | AFTER A COLLISION | 33 |
| PRE-CRASH SEAT BELT OPERATION INSPECTION | 16 | PRELIMINARY CHECKS | 33 |
| Diagnoses Symptom Chart | 16 | SEAT BELT RETRACTOR ON-VEHICLE CHECK | 34 |
| Check CAN Communication System Inspection [U1000] | 16 | SEAT BELT RETRACTOR OFF-VEHICLE CHECK (FRONT SEAT BELT) | 35 |
| Ignition Power Supply Circuit Check | 17 | SEAT BELT RETRACTOR OFF-VEHICLE CHECK (REAR SEAT BELT) | 35 |
| Motor Power Supply and Ground Circuit Check [B2454] | 17 | LATCH (LOWER ANCHORS AND TETHER FOR CHILDREN) SYSTEM | 36 |
| Seat Belt Buckle Switch (Driver Side) Circuit Check .. | 19 | Removal and Installation | 36 |
| Seat Belt Buckle Switch (Passenger Side) Circuit Check | 21 | REMOVAL | 36 |
| Brake Pedal Stroke Sensor Circuit Check [B2453].. .. | 22 | INSTALLATION | 36 |
| Pre-Crash Seat Belt Motor LHCircuit Check [B2452] | 25 | TOP TETHER STRAP CHILD RESTRAINT | 37 |
| Pre-Crash Seat Belt Motor RH Circuit Check | | Removal and Installation | 37 |
| | | REMOVAL | 37 |
| | | INSTALLATION | 37 |

PRECAUTIONS

PRECAUTIONS

PFP:00001

Precautions for Supplemental Restraint System (SRS) “AIR BAG” and “SEAT BELT PRE-TENSIONER”

NHS0007V

The Supplemental Restraint System such as “AIR BAG” and “SEAT BELT PRE-TENSIONER”, used along with a front seat belt, helps to reduce the risk or severity of injury to the driver and front passenger for certain types of collision. This system includes seat belt switch inputs and dual stage front air bag modules. The SRS system uses the seat belt switches to determine the front air bag deployment, and may only deploy one front air bag, depending on the severity of a collision and whether the front occupants are belted or unbelted. Information necessary to service the system safely is included in the SRS and SB section of this Service Manual.

WARNING:

- To avoid rendering the SRS inoperative, which could increase the risk of personal injury or death in the event of a collision which would result in air bag inflation, all maintenance must be performed by an authorized NISSAN/INFINITI dealer.
- Improper maintenance, including incorrect removal and installation of the SRS, can lead to personal injury caused by unintentional activation of the system. For removal of Spiral Cable and Air Bag Module, see the SRS section.
- Do not use electrical test equipment on any circuit related to the SRS unless instructed to in this Service Manual. SRS wiring harnesses can be identified by yellow and/or orange harnesses or harness connectors.

Precaution for Seat Belt Service

NHS0007W

CAUTION:

- Before removing the front seat belt pre-tensioner assembly, turn the ignition switch off, disconnect the both battery cables and wait at least 3 minutes.
- Do not use electrical test equipment for front seat belt pre-tensioner connector.
- After replacing or reinstalling front seat belt pre-tensioner assembly, or reconnecting front seat belt pre-tensioner connector, check the system function. Refer to [SRS-19, "SRS Operation Check"](#).
- Do not use disassemble buckle or seat belt assembly.
- Replace anchor bolts if they are deformed or worn out.
- Never oil tongue and buckle.
- If any component of seat belt assembly is questionable, do not repair. Replace the whole seat belt assembly.
- If webbing is cut, frayed, or damaged, replace seat belt assembly.
- When replacing seat belt assembly, use a genuine NISSAN seat belt assembly.

AFTER A COLLISION

WARNING:

Inspect all seat belt assemblies including retractors and attaching hardware after any collision. NISSAN recommends that all seat belt assemblies in use during a collision be replaced unless the collision was minor and the belts show no damage and continue to operate properly. Failure to do so could result in serious personal injury in an accident. Seat belt assemblies not in use during a collision should also be replaced if either damage or improper operation is noted. Seat belt pre-tensioner should be replaced even if the seat belts are not in use during a frontal collision in which the air bags are deployed.

Replace any seat belt assembly (including anchor bolts) if:

- The seat belt was in use at the time of a collision (except for minor collisions and the belts, retractors and buckles show no damage and continue to operate properly).
- The seat belt was damaged in an accident. (i.e. torn webbing, bent retractor or guide).
- The seat belt attaching point was damaged in an accident. Inspect the seat belt attaching area for damage or distortion and repair as necessary before installing a new seat belt assembly.
- Anchor bolts are deformed or worn out.
- The front seat belt pre-tensioner should be replaced even if the seat belts are not in use during the collision in which the air bags are deployed.

PRE-CRASH SEAT BELT

PRE-CRASH SEAT BELT

PFP:98845

Component Parts and Harness Connector Location

NHS0007X

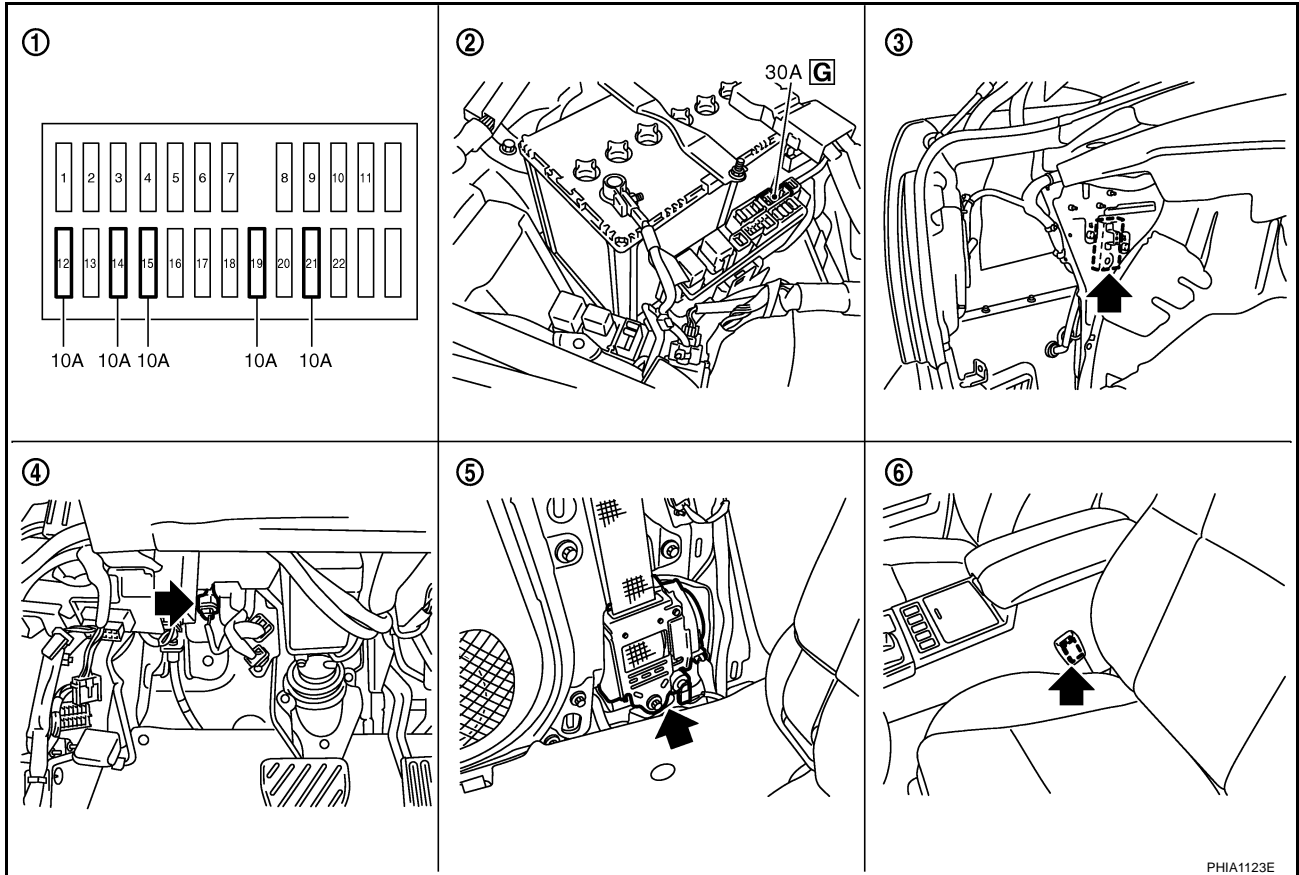

1. Fuse block (J/B)

2. Fuse, fusible link and relay block (J/B)

3. Pre-crash seat belt control unit B142 (View with the trunk side finisher LH removed)

4. Brake pedal stroke sensor E125 (View with the instrument driver lower panel removed)

5. Pre-crash seat belt motor B32 (LH), B8 (RH) (View with the center pillar lower garnish removed)

6. Seat belt buckle switch B203 (driver seat) B253 (passenger seat)

System Description

NHS0007Y

- Pre-crash seat belt system is adapted to front seat belts RH/LH.
- When the pre-crash seat belt control unit judges the emergency braking operation, it gives the sense of security by the motor built into the pre-crash seat belt retracting the shoulder belt and suppressing the crew's posture change. Also, it eases the damage of the collision.

A
B
C
D
E
F
G
SB
I
J
K
L
M

PRE-CRASH SEAT BELT

FUNCTION DESCRIPTION

Operation condition

Pre-crash seat belt operates under the following conditions.

| | |
|-----------|---|
| Condition | <ul style="list-style-type: none"> When the brake pedal is depressed more than a certain extent When operation prohibition condition is not satisfied |
|-----------|---|

Operation prohibition condition

If operation condition is satisfied, pre-crash seat belt does not operate under the following conditions.

| | |
|-----------|---|
| Condition | <ul style="list-style-type: none"> When seat belt is not fastened (Only the seat belt that is not fastened does not operate.) When vehicle is moving backwards When the vehicle speed is 15 km/h (9 MPH) or less When pre-crash seat belt continuously operates 3 times or more *¹ At fail-safe condition *² |
|-----------|---|

*¹ :When pre-crash seat belt doesn't operate after it continuously operates 3 times or more, operation can be performed again by stopping operation for approximately 7 minutes.

*² : Refer to [SB-4, "FAIL-SAFE MODE"](#) for details of fail-safe mode.

FAIL-SAFE MODE

When a malfunction occurs in the following system, the pre-crash seat belt function is controlled according to the malfunctioning parts.

Also, seat belt warning lamp blinks with fastening driver seat belt when the following malfunction occurs.

| Malfunctioning parts | Control contents |
|--|--|
| Brake pedal stroke sensor system malfunction | Pre-crash seat belt RH/LH do not activate when emergency brake operates. |
| Seat belt motor RH malfunction | Pre-crash seat belt RH does not activate. |
| Seat belt motor LH malfunction | Pre-crash seat belt LH does not activate. |
| Motor power supply circuit malfunction | Pre-crash seat belt RH/LH do not activate. |

Seat Belt Warning Lamp Illumination Pattern

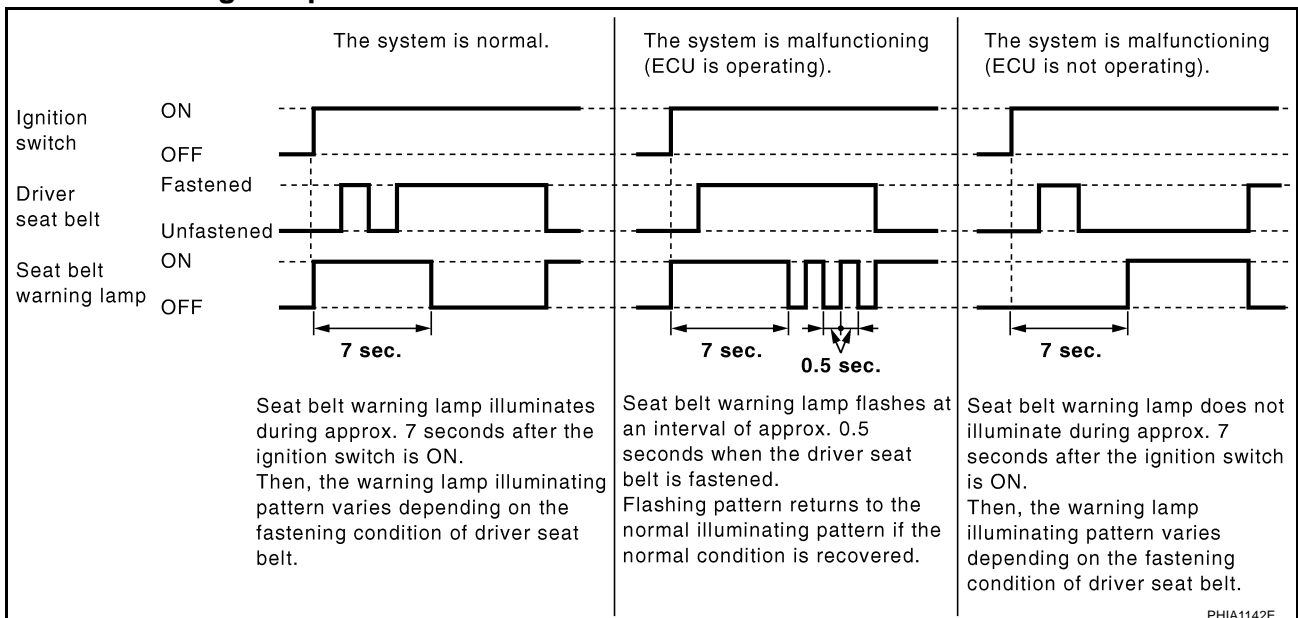

NOTE:

The seat belt warning lamp illumination system shown above operates only when the air bag system does not turn on the seat belt warning lamp. The air bag system turns on the seat belt warning lamp, depending on the conditions of passenger being on and the passenger seat belt fastening.

CAN Communication System Description

NHS0007Z

CAN (Controller Area Network) is a serial communication line for real time application. It is an on-vehicle multiplex communication line with high data communication speed and excellent error detection ability. Many electronic control units are equipped onto a vehicle, and each control unit shares information and links with other control units during operation (not independent). In CAN communication, control units are connected with 2 communication lines (CAN H line, CAN L line) allowing a high rate of information transmission with less wiring. Each control unit transmits/receives data but selectively reads required data only.

CAN Communication Unit

NHS00080

Refer to [LAN-34, "CAN Communication Unit"](#) .

A

B

C

D

E

F

G

SB

I

J

K

L

M

PRE-CRASH SEAT BELT

Schematic

NHS00081

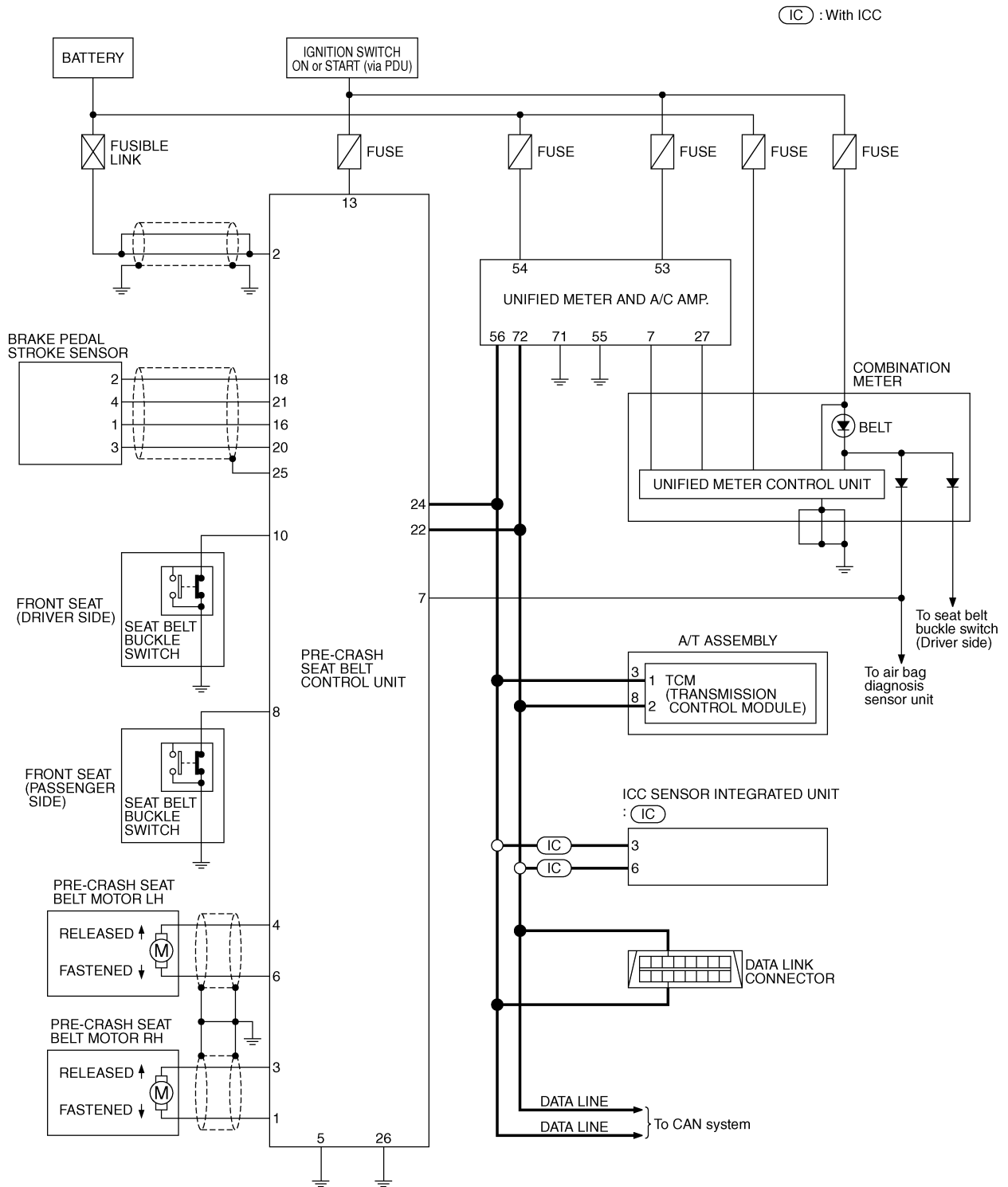

THWT0139E

PRE-CRASH SEAT BELT

Wiring Diagram — PSB —

NHS00082

SB-PSB-01

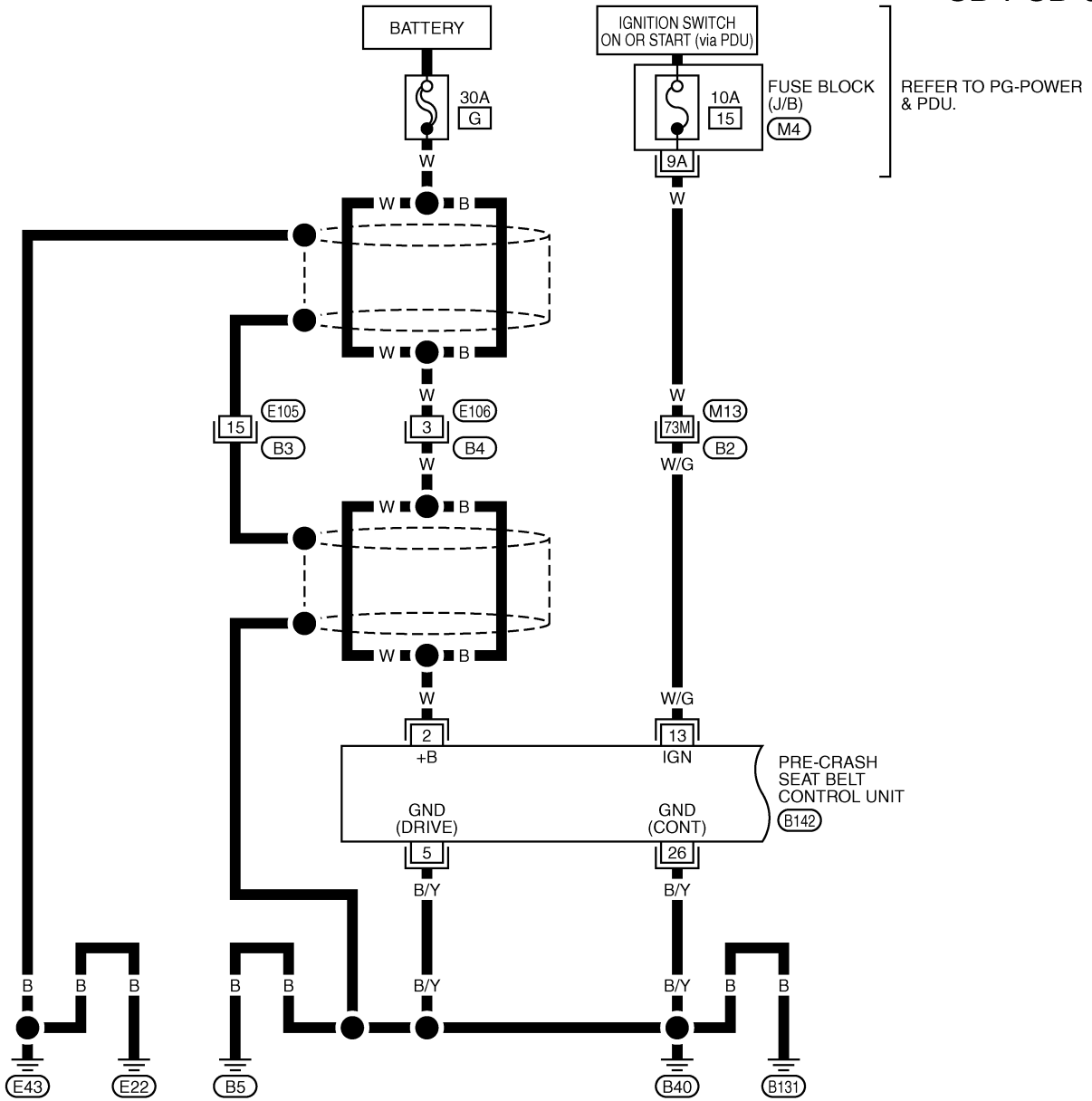

A
B
C
D
E
F
G
SB
I
J
K
L
M

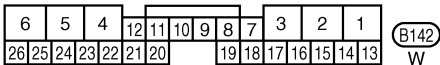
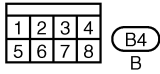
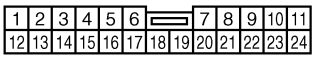

REFER TO THE FOLLOWING.

- (B2) -SUPER MULTIPLE JUNCTION (SMJ)
- (M4) -FUSE BLOCK-JUNCTION BOX (J/B)

THWT0140E

PRE-CRASH SEAT BELT

SB-PSB-02

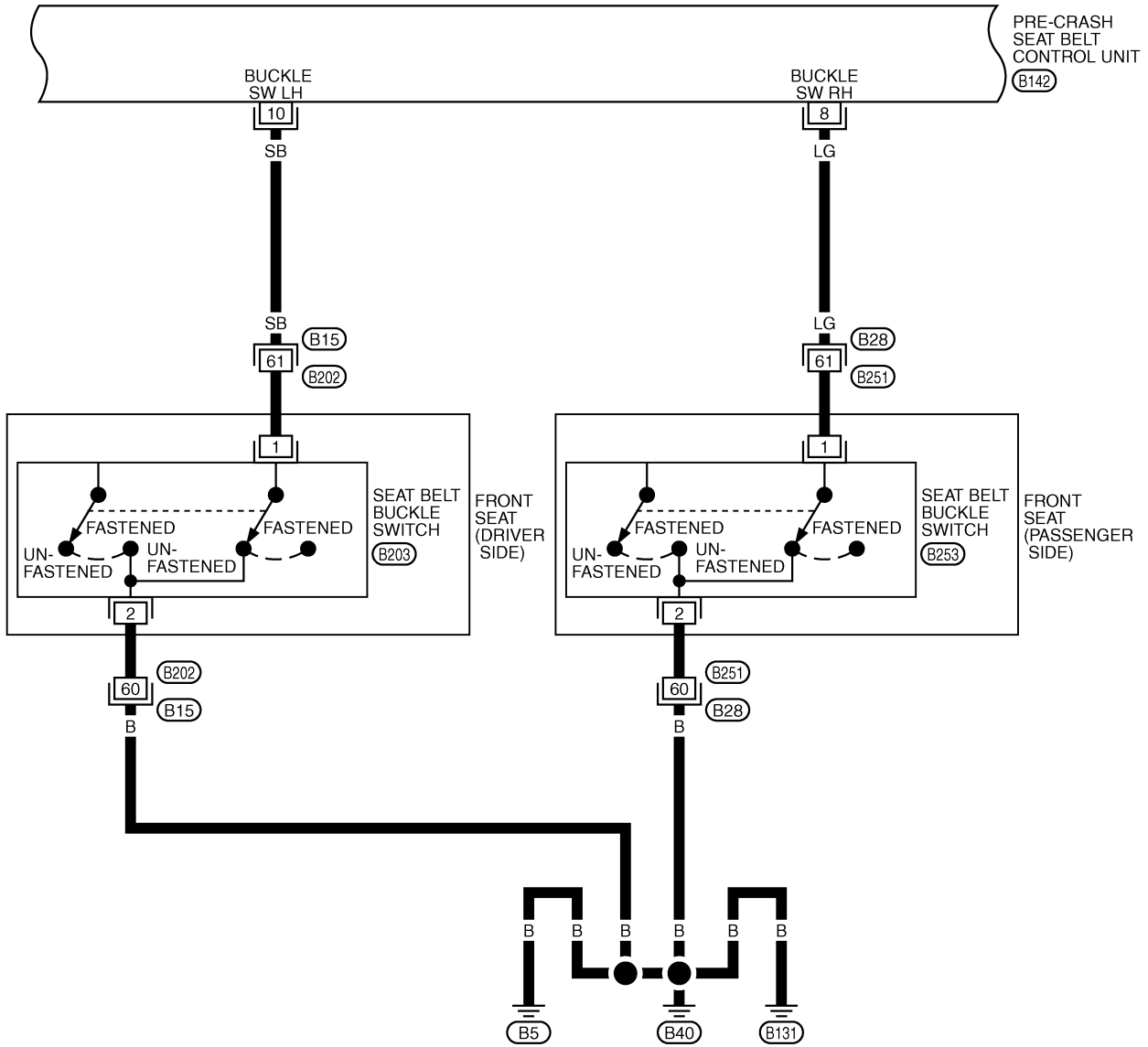

| | | | | |
|----|----|----|----|----|
| 19 | 3 | 1 | 17 | 40 |
| 61 | 60 | 59 | 32 | 48 |
| 21 | 33 | | | |

(B15) W

| | | | | | | | | | |
|----|----|----|----|----|----|----|----|----|----|
| 80 | 55 | 54 | 7 | 61 | 60 | 59 | 53 | 52 | 51 |
| 16 | 58 | 4 | 57 | 5 | 48 | 6 | 33 | | |

(B28) W

| | | | | | | | | | | | |
|----|----|----|----|----|----|----|---|---|----|----|----|
| 6 | 5 | 4 | 12 | 11 | 10 | 9 | 8 | 7 | 3 | 2 | 1 |
| 26 | 25 | 24 | 23 | 22 | 21 | 20 | | | 19 | 18 | 17 |
| 16 | 15 | 14 | 13 | | | | | | | | |

(B142) W

| |
|---|
| 1 |
| 2 |
| 3 |

(B203) W *

(B253) W *

*: THIS CONNECTOR IS NOT SHOWN IN "HARNES LAYOUT", PG SECTION.

THWT0141E

PRE-CRASH SEAT BELT

SB-PSB-03

A
B
C
D
E
F
G
SB
I
J
K
L
M

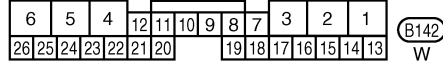
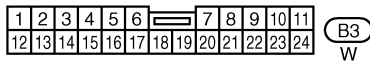
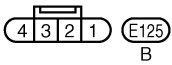
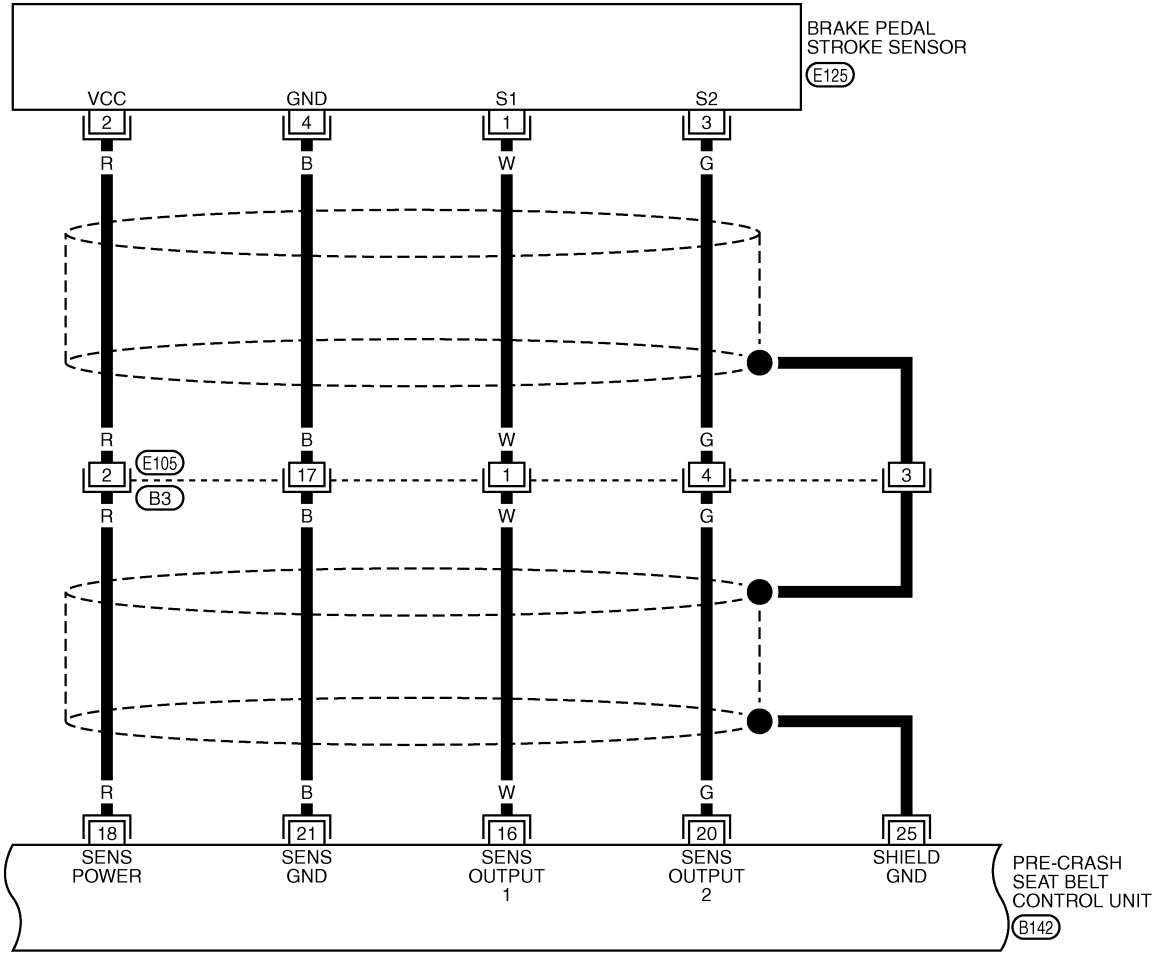

THWT0142E

PRE-CRASH SEAT BELT

SB-PSB-04

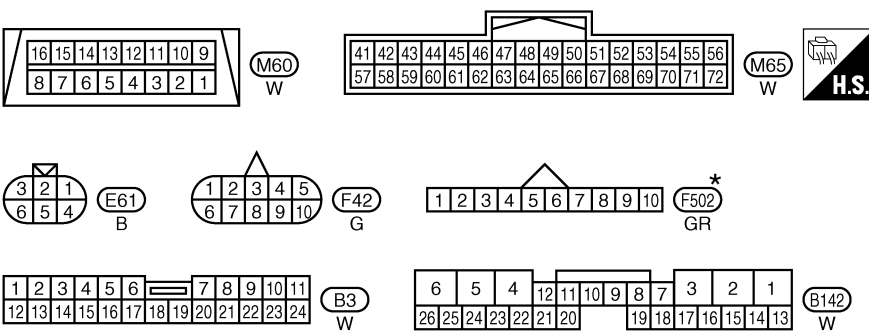
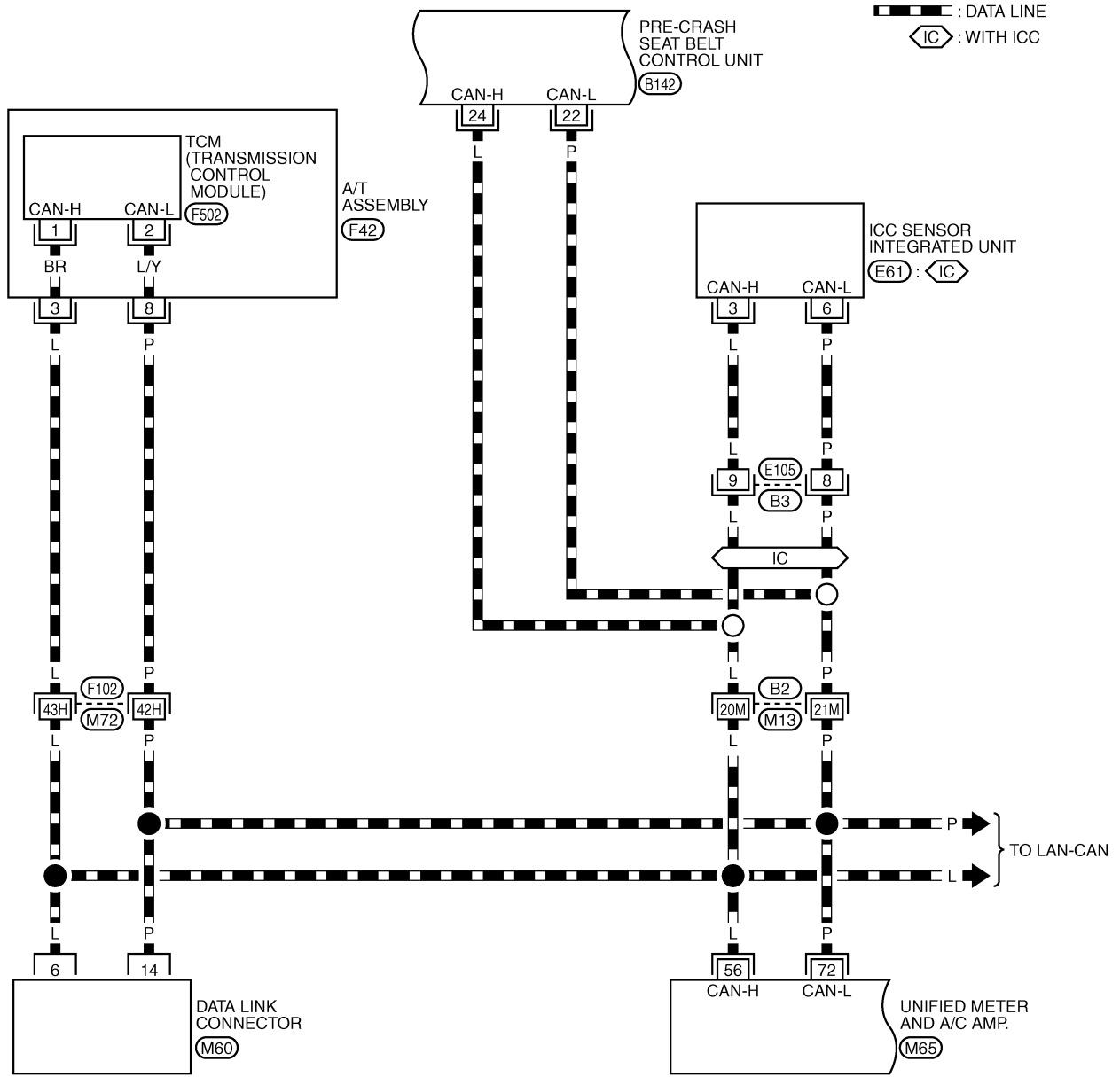

REFER TO THE FOLLOWING.
 (F102), (B2) -SUPER MULTIPLE JUNCTION (SMJ)

*: THIS CONNECTOR IS NOT SHOWN IN "HARNES LAYOUT", PG SECTION.

THWT0143E

PRE-CRASH SEAT BELT

SB-PSB-05

A
B
C
D
E
F
G
SB
I
J
K
L
M

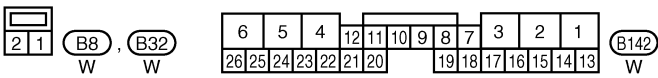
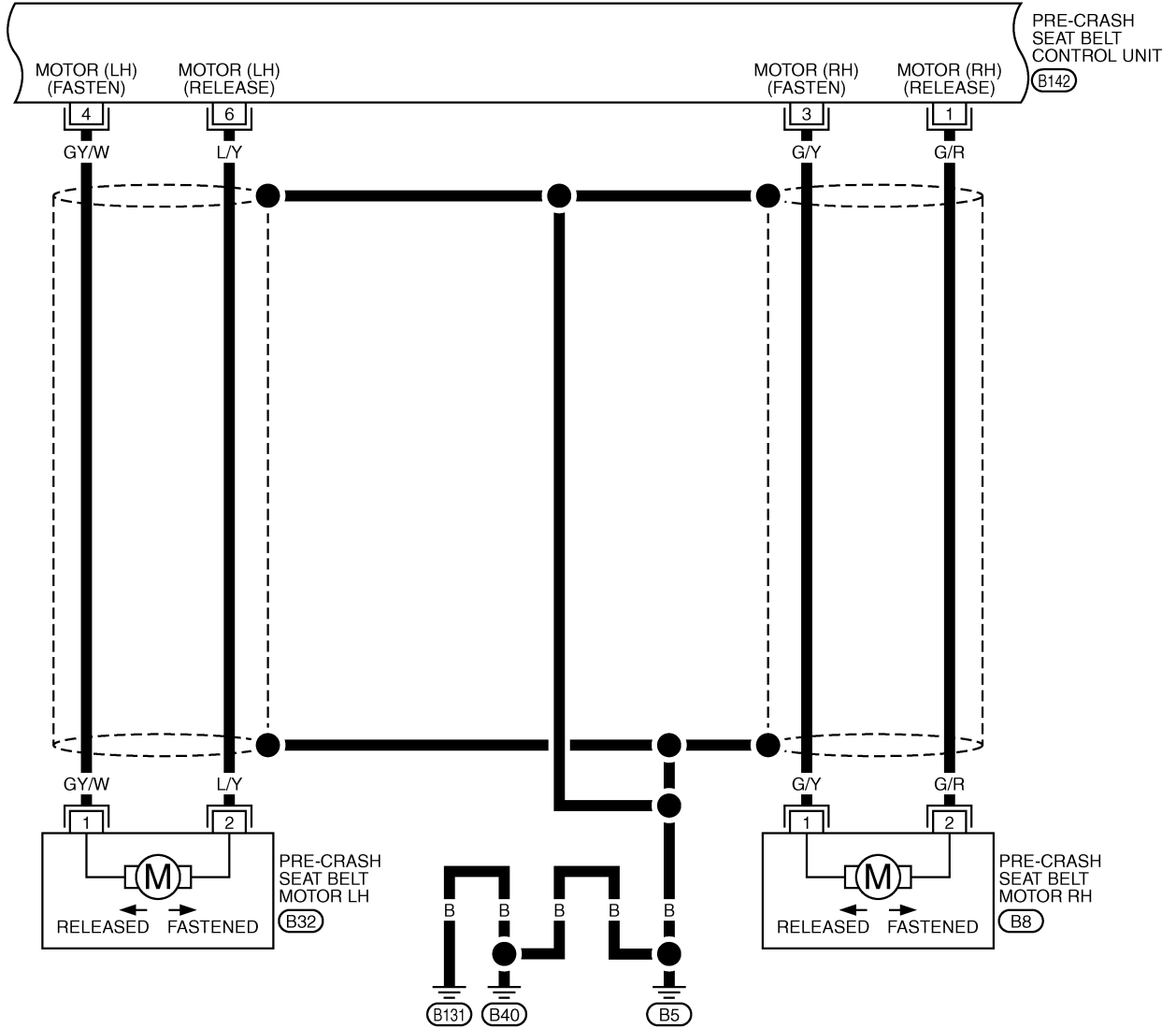

THWT0144E

PRE-CRASH SEAT BELT

Terminals and Reference Value for Pre-Crash Seat Belt Control Unit

NHS00083

| Terminal | Wire Color | Item | Condition | Voltage [V] (Approx.) |
|----------|------------|--|---|--------------------------|
| 1 | G/R | Seat belt motor RH release direction signal | Seat belt motor RH operation | Battery voltage |
| | | | Other than above | 0 |
| 2 | W | Power source (BAT) | – | Battery voltage |
| 3 | G/Y | Seat belt motor RH fastened direction signal | Seat belt motor RH operation | Battery voltage |
| | | | Other than above | 0 |
| 4 | GY/W | Seat belt motor LH fastened direction signal | Seat belt motor LH operation | Battery voltage |
| | | | Other than above | 0 |
| 5 | B/Y | Ground (Driver circuit) | – | 0 |
| 6 | L/Y | Seat belt motor LH release direction signal | Seat belt motor LH operation | Battery voltage |
| | | | Other than above | 0 |
| 7 | G/Y | Seat belt indicator signal | When driver side seat belt is fastened | Battery voltage |
| | | | When driver side seat belt is un-fastened | 0 |
| | | | When driver side seat belt is fastened and system malfunction | Battery voltage↔ 0 |
| 8 | LG | Seat belt buckle switch RH | When seat belt is fastened | 5 |
| | | | When seat belt is un-fastened | 0 |
| 10 | SB | Seat belt buckle switch LH | When seat belt is fastened | Battery voltage |
| | | | When seat belt is un-fastened | 0 |
| 13 | W/G | Power source (IGN) | Ignition switch ON or START | Battery voltage |
| 16 | W | Brake pedal stroke sensor output signal 1 | Brake pedal is fully released operation | 1 |
| | | | Brake pedal is slightly depressed operation | 4 |
| 18 | R | Power source (Brake pedal stroke sensor) | – | 5 |
| 20 | G | Brake pedal stroke sensor output signal 2 | Brake pedal is fully released operation | 4 |
| | | | Brake pedal is slightly depressed operation | 1 |
| 21 | B | Ground (Brake pedal stroke sensor) | – | 0 |
| 22 | P | CAN-L | – | - |
| 24 | L | CAN-H | – | - |
| 25 | – | Ground (Shield wire) | – | 0 |
| 26 | B/Y | Ground (Control circuit) | – | 0 |

Work Flow

NHS00084

1. Check the symptom and customer's requests.
2. Understand the system description. Refer to [SB-3, "System Description"](#).
3. Perform the preliminary check. Refer to [SB-16, "Preliminary Check"](#).
4. Check the self-diagnosis, results using CONSULT-II. Refer to [SB-14, "CONSULT-II Function \(PRECRASH SEATBELT\)"](#).
5. Based on the trouble diagnosis chart, repair or replace the cause of the malfunction. Refer to [SB-16, "Diagnoses Symptom Chart"](#).
6. Does pre-crash seat belt system operate normally?
OK: GO TO 7.
NG: GO TO 4.
7. INSPECTION END

PRE-CRASH SEAT BELT

NHS00085

CONSULT-II Function (PRECRASH SEATBELT)

CONSULT-II can display each diagnostic item using the diagnostic test modes shown following.

| CONSULT-II diagnosis items | Inspection item self-diagnosis mode | Content | Reference page |
|----------------------------|-------------------------------------|---|------------------------|
| PRECRASH SEATBELT | SELF-DIAG RESULTS | Carries out the self-diagnosis. | SB-15 |
| | DATA MONITOR | Displays pre-crash seat belt control unit input data in real time. | SB-15 |
| | CAN DIAG SUPPORT MNTR | The results of transmit / receive diagnosis of CAN communication can be read. | LAN-20 |
| | ECU PART NUMBER | Displays pre-crash seat belt control unit part No. | - |

CONSULT-II INSPECTION PROCEDURE

CAUTION:

If CONSULT-II is used with no connection of CONSULT-II CONVERTER, malfunctions might be detected in self-diagnosis depending on control unit which carry out CAN communication.

1. Turn ignition switch "OFF".
2. Connect "CONSULT-II" and "CONSULT-II CONVERTER" to the data link connector (1).

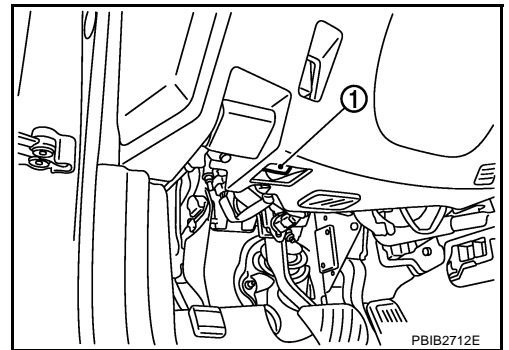

3. Turn ignition switch "ON".
4. Touch "START (NISSAN BASED VHCL)".

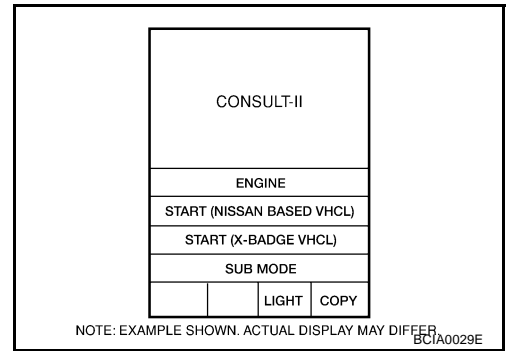

5. Touch "PRECRASH SEATBELT".
If "PRECRASH SEATBELT" is not indicated, refer to [GI-40](#), "[CONSULT-II Data Link Connector \(DLC\) Circuit](#)".

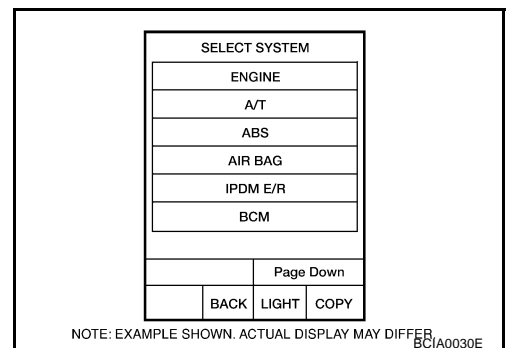

PRE-CRASH SEAT BELT

6. Select diagnosis mode.
 “SELF-DIAG RESULTS”, “DATA MONITOR”, “CAN DIAG SUP-PORT MNTR” and “ECU PART NUMBER” are available.

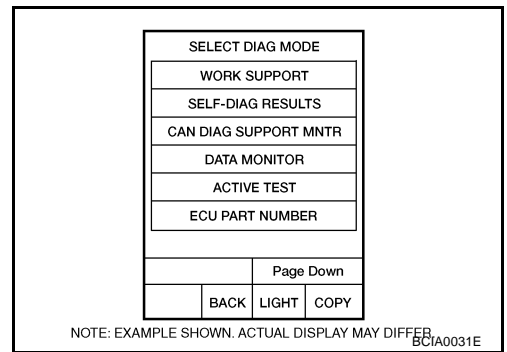

HOW TO READ SELF-DIAGNOSTIC RESULTS

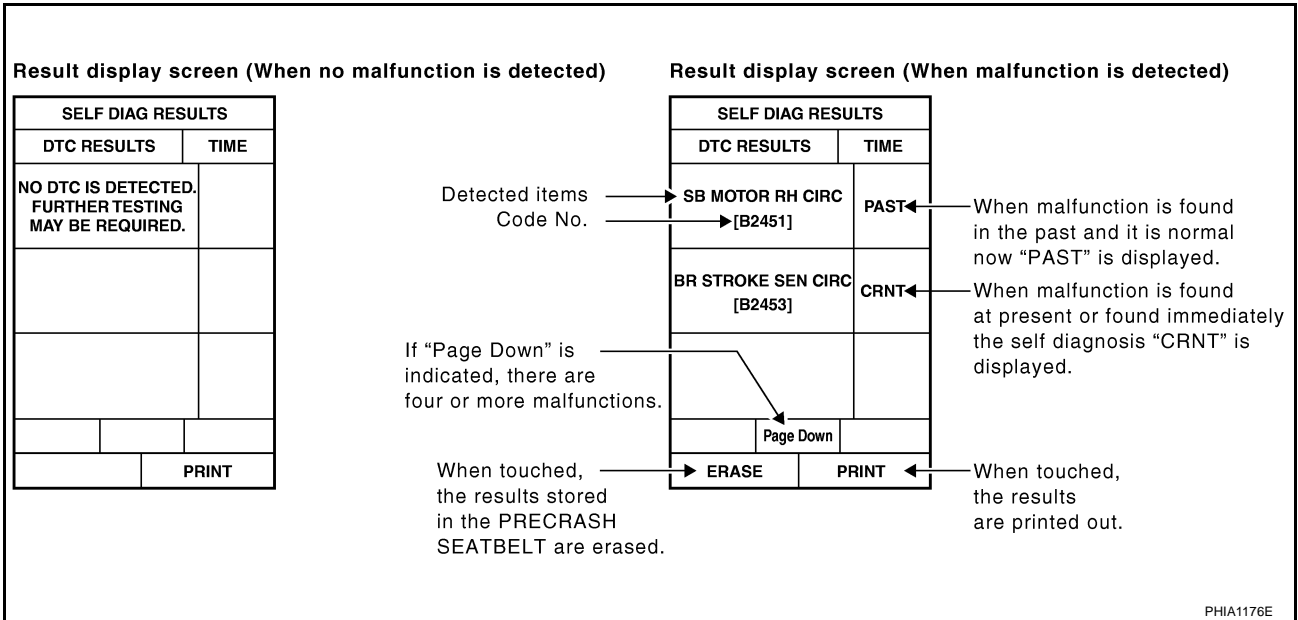

SELF-DIAGNOSTIC RESULTS ITEM CHART

| CONSULT-II display | Item | Malfunction is detected when... | Reference page |
|-----------------------------|----------------------------|--|-----------------------|
| CAN COMM CIRCUIT [U1000] | CAN communication | Malfunction is detected in CAN communication. | SB-16 |
| SB MOTOR RH CIRC [B2451] | Seat belt motor RH | Circuit of seat belt motor (RH) is open or shorted. | SB-27 |
| SB MOTOR LH CIRC [B2452] | Seat belt motor LH | Circuit of seat belt motor (LH) is open or shorted. | SB-25 |
| BR STROKE SEN CIRC [B2453] | Brake pedal stroke sensor | Circuit of brake pedal stroke sensor is open or shorted. | SB-22 |
| MOTOR PWR SUP CIRC [B2454] | Motor power supply circuit | Circuit of motor power supply is open or shorted. | SB-17 |
| PSB C/U INT CIRCUIT [B2455] | ECU circuit | ECU circuit internal abnormality | — |

DATA MONITOR ITEM CHART

| Monitor item [OPERATION or UNIT] | Contents |
|----------------------------------|--|
| SB SW RH SIG | “ON/OFF” RH seat belt switch signal is displayed. |
| SB SW LH SIG | “ON/OFF” LH seat belt switch signal is displayed. |
| VHCL SPEED SE | “Km/h” Vehicle speed signal is displayed. |
| B PEDAL SIG1 | “V” Brake pedal stroke sensor 1 signal voltage is displayed. |
| B PEDAL SIG 2 | “V” Brake pedal stroke sensor 2 signal voltage is displayed. |

PRE-CRASH SEAT BELT

Preliminary Check PRE-CRASH SEAT BELT OPERATION INSPECTION

NHS00086

WARNING:

- The following tests should be performed in a safe, open place that is free of traffic and obstacles.
 - The tests should be performed on a dry, paved road. Do not attempt the tests on wet or unpaved road, open road, or highway. (This may cause an accident or personal injury.)
 - Driver and passenger assume it will not operate and prepare themselves accordingly.
1. Tighten driver and passenger seat belts.
 2. Drive at approximately 25 km/h (16 MPH).
 3. Notify passenger of a sudden stop. Driver and passenger prepare themselves for the possibility of system not operating. Then, driver fully depresses the brake pedal to stop suddenly.
 4. Make sure that the shoulder of the seat belt is pulled while braking.

Diagnoses Symptom Chart

NHS00087

| Symptom | Diagnosis procedure | Reference page |
|---|--|-----------------------|
| All functions of pre-crash seat belt system does not operate. | Ignition power supply circuit check | SB-17 |
| | Motor power supply and ground circuit check | SB-17 |
| | CAN communication circuit check | SB-16 |
| | Replace pre-crash seat belt control unit. | SB-29 |
| Driver side pre-crash seat belt system does not operate. | Seat belt buckle switch (driver side) circuit check | SB-19 |
| | Pre-crash seat belt motor LH check | SB-25 |
| | Replace pre-crash seat belt control unit. | SB-29 |
| Passenger side pre-crash seat belt system does not operate. | Seat belt buckle switch (passenger side) circuit check | SB-21 |
| | Pre-crash seat belt motor RH check | SB-27 |
| | Replace pre-crash seat belt control unit. | SB-29 |
| Pre-crash seat belt system does not operate during emergency brake operation. | CAN communication circuit check | SB-16 |
| | Brake pedal stroke sensor circuit check | SB-22 |
| | Brake pedal stroke sensor shield wire circuit check | SB-28 |
| | Replace pre-crash seat belt control unit. | SB-29 |

Check CAN Communication System Inspection [U1000]

NHS00088

1. CHECK SELF-DIAGNOSTIC RESULT

CAUTION:

If CONSULT-II is used with no connection of CONSULT-II CONVERTER, malfunctions might be detected in self-diagnosis depending on control unit which carry out CAN communication.

With CONSULT-II

1. Connect CONSULT-II, and turn ignition switch ON.
2. Touch "PRECRASH SEATBELT" on "SELECT SYSTEM" screen.
3. Touch "SELF-DIAG RESULTS" on "SELECT DIAG MODE" screen.
4. Check display content in self-diagnostic results.

Displayed U1000?

- Yes >> GO TO [LAN-7, "Precautions When Using CONSULT-II"](#) .
 No >> Inspection END.

| SELF-DIAG RESULTS | | | |
|--------------------------|------|-------|------|
| DTC RESULTS | | TIME | |
| CAN COMM CIRCUIT [U1000] | | CRNT | |
| | | | |
| | | | |
| | | | |
| ERASE | | PRINT | |
| MOOE | BACK | LIGHT | COPY |

PHIA0772E

PRE-CRASH SEAT BELT

Ignition Power Supply Circuit Check

NHS00089

1. CHECK FUSE

Check 10A fuse [No.15, located in fuse block (J/B)].

NOTE:

Refer to [SB-3, "Component Parts and Harness Connector Location"](#) .

OK or NG

OK >> GO TO 2.

NG >> If fuse is blown out, be sure to eliminate cause of malfunction before installing new fuse. Refer to [PG-3, "POWER SUPPLY ROUTING CIRCUIT"](#) .

2. CHECK IGNITION POWER SUPPLY CIRCUIT

1. Disconnect pre-crash seat belt control unit connector.
2. Turn ignition switch ON.
3. Check voltage between pre-crash seat belt control unit harness connector and ground.

| Terminal (+) | | Terminal (-) | Voltage (V) (Approx.) |
|--|----------|--------------|--------------------------|
| Pre-crash seat belt control unit connector | Terminal | | |
| B142 | 13 | Ground | Battery voltage |

OK or NG

OK >> Ignition power supply circuit is OK.

NG >> Check pre-crash seat belt control unit ignition power supply circuit harness.

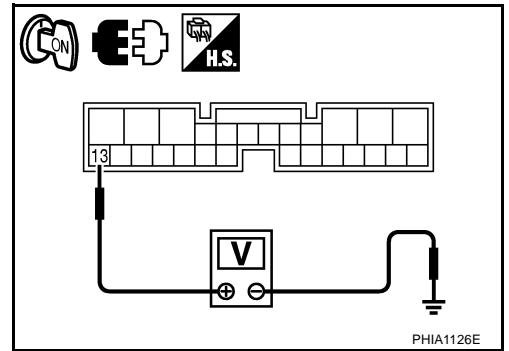

Motor Power Supply and Ground Circuit Check [B2454]

NHS0008A

1. CHECK FUSE

Check 30A fusible link (letter **G** , located in the fuse and fusible link box).

NOTE:

Refer to [SB-3, "Component Parts and Harness Connector Location"](#) .

OK or NG

OK >> GO TO 2.

NG >> If fuse is blown out, be sure to eliminate cause of malfunction before installing new fuse. Refer to [PG-3, "POWER SUPPLY ROUTING CIRCUIT"](#) .

PRE-CRASH SEAT BELT

2. CHECK MOTOR POWER SUPPLY CIRCUIT 1

With CONSULT-II

Select "SELF-DIAG RESULTS" and then make sure the "MOTOR PWR SUP CIRC" is displayed.

| CONSULT-II display | CONSULT-II display code |
|--------------------|-------------------------|
| NO DTC | - |
| MOTOR PWR SUP CIRC | B2454 |

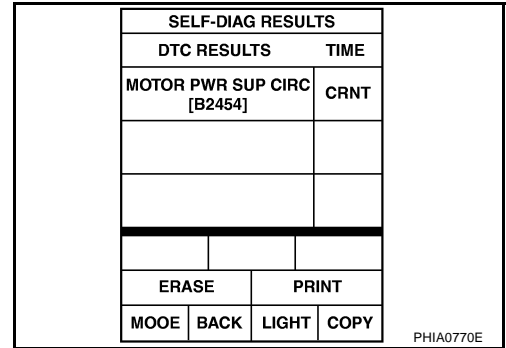

Without CONSULT-II

When CONSULT-II is not used, omit this inspection, and then GO TO 3.

Displayed B2454?

- Yes >> GO TO 3.
- No >> Motor power supply system is normal.

3. CHECK MOTOR POWER SUPPLY CIRCUIT 2

1. Disconnect pre-crash seat belt control unit connector.
2. Check voltage between pre-crash seat belt control unit harness connector and ground.

| Terminal (+) | | Terminal (-) | Voltage (V) (Approx.) |
|--|----------|--------------|--------------------------|
| Pre-crash seat belt control unit connector | Terminal | | |
| B142 | 2 | Ground | Battery voltage |

OK or NG

- OK >> GO TO 4.
- NG >> Repair or replace harness.

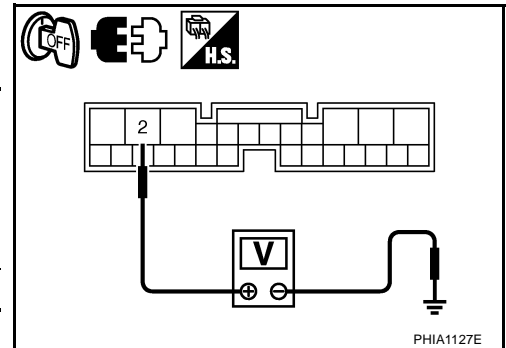

4. CHECK PRE-CRASH SEAT BELT CONTROL UNIT GROUND CIRCUIT

1. Disconnect pre-crash seat belt control unit connector.
2. Check continuity between pre-crash seat belt control unit harness connector and ground.

| Terminal | | Ground | Continuity |
|--|----------|--------|------------|
| Pre-crash seat belt control unit connector | Terminal | | |
| B142 | 5 | Ground | Yes |
| | 26 | | |

OK or NG

- OK >> Motor power supply and ground circuit is OK.
- NG >> Repair or replace harness.

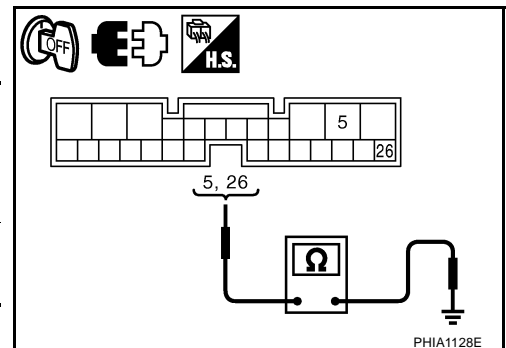

PRE-CRASH SEAT BELT

Seat Belt Buckle Switch (Driver Side) Circuit Check

NHS0008B

1. CHECK PRE-CRASH SEAT BELT CONTROL UNIT INPUT SIGNAL

With CONSULT-II

Select "SB SW LH SIG" on DATA MONITOR screen, and then make sure that ON/OFF display changes synchronized with the insertion operation to the seat belt buckle.

SB SW LH SIG

When driver seat belt is not fastened : OFF

When driver seat belt is fastened : ON

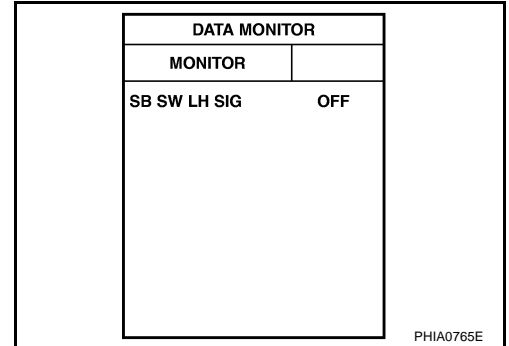

Without CONSULT-II

- Turn the ignition switch ON.
- Check voltage between seat belt buckle switch (driver side) harness connector and ground.

| Terminal (+) | | Terminal (-) | Condition | Voltage (V) (Approx.) |
|---|----------|--------------|------------------------------|-----------------------|
| Seat belt buckle switch connector (driver side) | Terminal | | | |
| B203 | 1 | Ground | When seat belt is unfastened | 0 |
| | | | When seat belt is fastened | Battery voltage |

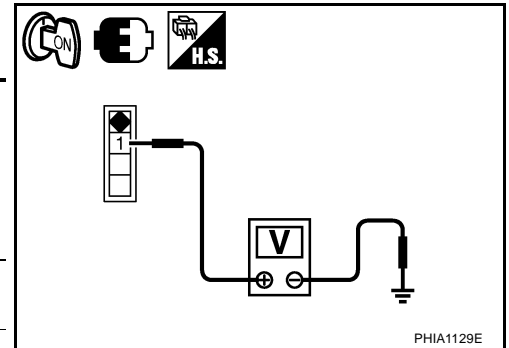

OK or NG

- OK >> Seat belt buckle switch (driver side) circuit is OK.
 NG >> GO TO 2.

PRE-CRASH SEAT BELT

2. CHECK SEAT BELT BUCKLE SWITCH (DRIVER SIDE) HARNESS

1. Turn the ignition switch OFF.
2. Disconnect pre-crash seat belt control unit and seat belt buckle switch (driver side) connector.
3. Check continuity between pre-crash seat belt control unit harness connector and seat belt buckle switch (driver side) harness connector.

| A | | B | | Continuity |
|--|----------|---|----------|------------|
| Pre-crash seat belt control unit connector | Terminal | Seat belt buckle switch (driver side) connector | Terminal | |
| B142 | 10 | B203 | 1 | Yes |

4. Check continuity between pre-crash seat belt control unit harness connector and ground.

| A | | Ground | Continuity |
|--|----------|--------|------------|
| Pre-crash seat belt control unit connector | Terminal | | |
| B142 | 10 | | No |

OK or NG

- OK >> GO TO 3.
 NG >> Repair or replace harness.

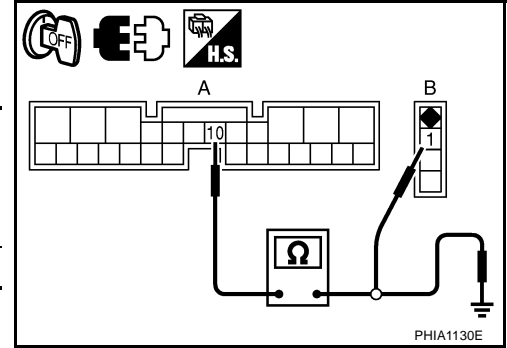

3. CHECK LH SEAT BELT SWITCH

Check continuity between seat belt buckle switch (driver side) while performing the insertion operation to the seat belt buckle.

| Seat belt buckle switch connector (driver side) | Terminal | | Condition | Continuity |
|---|----------|---|------------------------------|------------|
| | 1 | 2 | | |
| B203 | 1 | 2 | When seat belt is unfastened | Yes |
| | | | When seat belt is fastened | No |

OK or NG

- OK >> GO TO 4.
 NG >> Replace seat belt buckle switch (driver side).

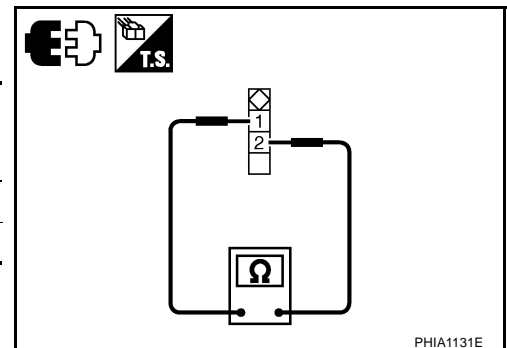

4. CHECK LH SEAT BELT SWITCH GROUND CIRCUIT HARNNES

Check continuity between seat belt buckle switch (driver side) harness connector and ground.

| Terminal | | Ground | Continuity |
|---|----------|--------|------------|
| Seat belt buckle switch connector (driver side) | Terminal | | |
| B203 | 2 | | Yes |

OK or NG

- OK >> Check harness connection.
- If it is OK, replace pre-crash seat belt control unit.
 - If it is NG, repair or replace malfunction part.
- NG >> Repair or replace harness.

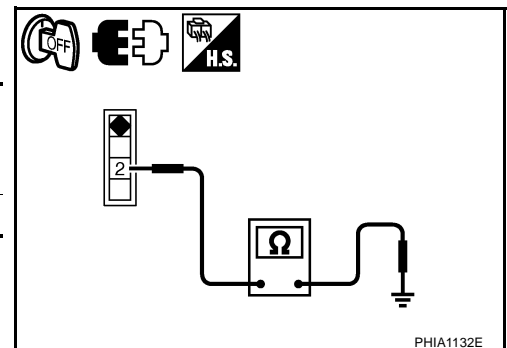

PRE-CRASH SEAT BELT

Seat Belt Buckle Switch (Passenger Side) Circuit Check

NHS0008C

1. CHECK PRE-CRASH SEAT BELT CONTROL UNIT INPUT SIGNAL

With CONSULT-II

Select "SB SW RH SIG" on DATA MONITOR screen, and then make sure that ON/OFF display changes synchronized with the insertion operation to the seat belt buckle.

SB SW RH SIG

When passenger seat belt is not fastened :OFF

When passenger seat belt is fastened :ON

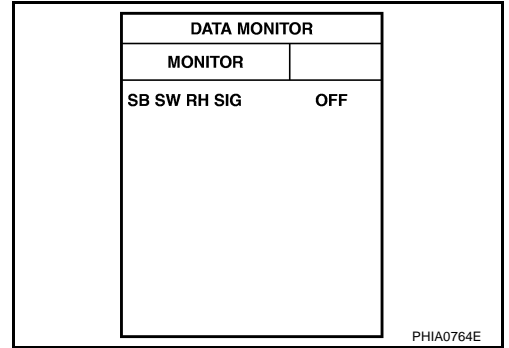

Without CONSULT-II

1. Turn the ignition switch ON.
2. Check voltage between seat belt buckle switch (passenger side) harness connector and ground.

| Terminal | | Condition | Voltage (V) (Approx.) |
|--|----------|------------------------------|--------------------------|
| (+) | (-) | | |
| Seat belt buckle switch connector (passenger side) | Terminal | | |
| B253 | 1 | When seat belt is unfastened | 0 |
| | | When seat belt is fastened | 5 |

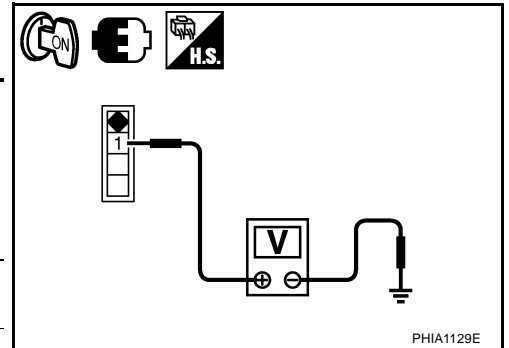

OK or NG

OK >> Seat belt buckle switch (passenger side) circuit is OK.

NG >> GO TO 2.

2. CHECK SEAT BELT BUCKLE SWITCH (PASSENGER SIDE) HARNESS

1. Turn ignition switch OFF.
2. Disconnect pre-crash seat belt control unit and seat belt buckle switch (passenger side) connector.
3. Check continuity between pre-crash seat belt control unit harness connector and seat belt buckle switch (passenger side) harness connector.

| A | | B | | Continuity |
|--|----------|--|----------|------------|
| Pre-crash seat belt control unit connector | Terminal | Seat belt buckle switch (passenger side) connector | Terminal | |
| B142 | 8 | B253 | 1 | Yes |

4. Check continuity between pre-crash seat belt control unit harness connector and ground.

| A | | Ground | Continuity |
|--|----------|--------|------------|
| Pre-crash seat belt control unit connector | Terminal | | |
| B142 | 8 | | No |

OK or NG

OK >> GO TO 3.

NG >> Repair or replace harness.

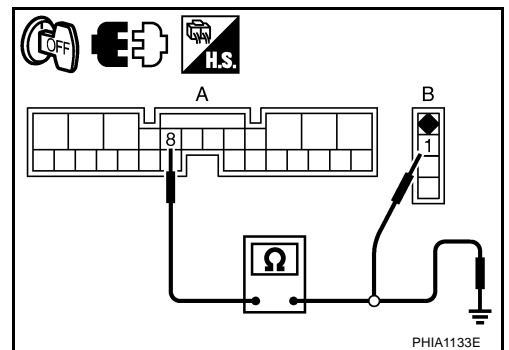

PRE-CRASH SEAT BELT

3. CHECK RH SEAT BELT SWITCH

Check continuity between seat belt buckle switch (passenger side) while performing the insertion operation to the seat belt buckle.

| Seat belt buckle switch connector (passenger side) | Terminal | | Condition | Continuity |
|--|----------|---|------------------------------|------------|
| | 1 | 2 | | |
| B253 | 1 | 2 | When seat belt is unfastened | Yes |
| | | | When seat belt is fastened | No |

OK or NG

OK >> GO TO 4.

NG >> Replace seat belt buckle (passenger side).

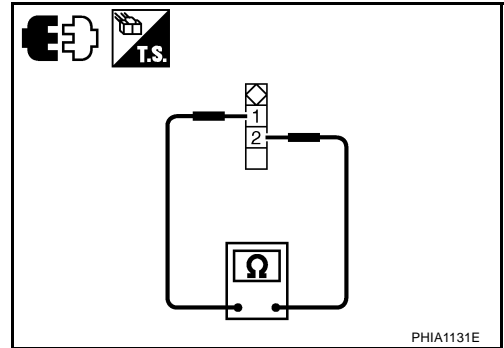

4. CHECK RH SEAT BELT SWITCH GROUND CIRCUIT HARNNES

Check continuity between seat belt buckle switch (passenger side) harness connector and ground.

| Seat belt buckle switch connector (passenger side) | Terminal | | Ground | Continuity |
|--|----------|--|--------|------------|
| | Terminal | | | |
| B253 | 2 | | | Yes |

OK or NG

OK >> Check harness connection.

- If it is OK, replace pre-crash seat belt control unit.
- If it is NG, repair or replace malfunction part.

NG >> Repair or replace harness.

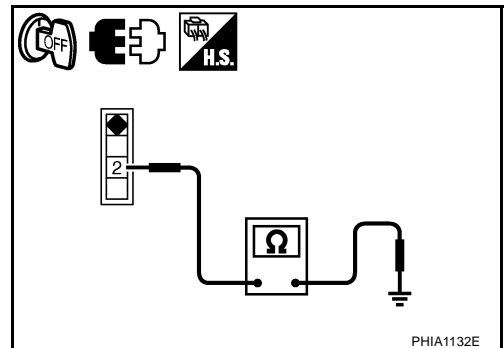

Brake Pedal Stroke Sensor Circuit Check [B2453]

NHS0008D

1. INSPECTION WITH CONSULT-II

With CONSULT-II

Select "SELF-DIAG RESULTS", and then make sure that "BR STROKE SEN CIRC" is displayed.

| CONSULT-II display | CONSULT-II display code |
|--------------------|-------------------------|
| NO DTC | - |
| BR STROKE SEN CIRC | B2453 |

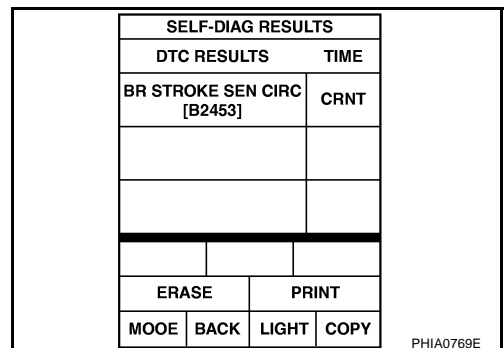

Without CONSULT-II

When CONSULT-II is not used, omit this inspection, and then GO TO 2.

Displayed B2453?

Yes >> GO TO 3.

No >> GO TO 2.

PRE-CRASH SEAT BELT

2. CHECK PRE-CRASH SEAT BELT CONTROL UNIT INPUT SIGNAL

Ⓟ With CONSULT-II

Select "B PEDAL SIG1" and "B PEDAL SIG2", and then make sure that the voltage changes synchronized with brake pedal operation.

B PEDAL SIG1

Brake released → depressed : Approx. 1 → 4V

B PEDAL SIG2

Brake released → depressed : Approx. 4 → 1V

| DATA MONITOR | |
|--------------|-------|
| MONITOR | |
| B PEDAL SIG1 | 1.10V |
| B PEDAL SIG2 | 3.98V |

PHIA0766E

⊗ Without CONSULT-II

- Turn the ignition switch ON.
- Check voltage between pre-crash seat belt control unit harness connector and ground.

| Terminal (+) | | Terminal (-) | Condition | Voltage (V) (Approx.) |
|--|----------|--------------|----------------------------|-----------------------|
| Pre-crash seat belt control unit connector | Terminal | | | |
| B142 | 16 | Ground | Brake released → depressed | 1 → 4 |
| | 20 | | | 4 → 1 |

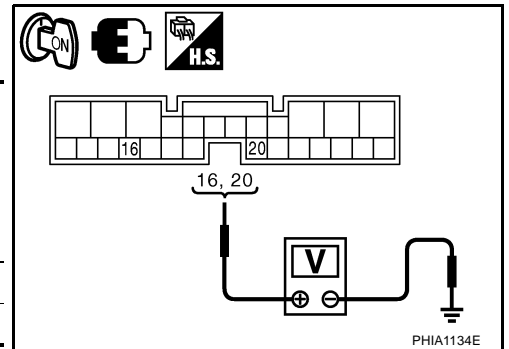

OK or NG

- OK >> Brake pedal stroke sensor system is normal.
 NG >> GO TO 3.

PRE-CRASH SEAT BELT

3. CHECK BRAKE PEDAL STROKE SENSOR HARNESS

1. Turn the ignition switch OFF.
2. Disconnect pre-crash seat belt control unit connector and brake pedal stroke sensor connector.
3. Check continuity between pre-crash seat belt control unit harness connector and brake pedal stroke sensor harness connector.

| A | | B | | Continuity |
|--|----------|-------------------------------------|----------|------------|
| Pre-crash seat belt control unit connector | Terminal | Brake pedal stroke sensor connector | Terminal | |
| B142 | 16 | E125 | 1 | Yes |
| | 18 | | 2 | |
| | 20 | | 3 | |
| | 21 | | 4 | |

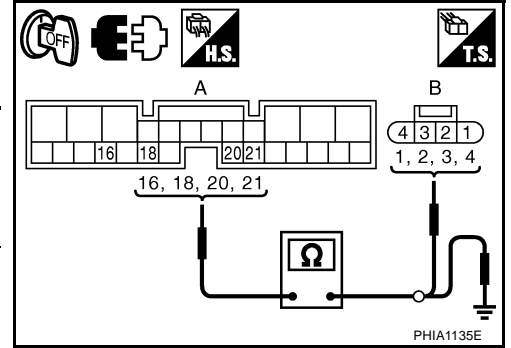

4. Check continuity between pre-crash seat belt control unit harness connector and ground.

| A | | Ground | Continuity |
|--|----------|--------|------------|
| Pre-crash seat belt control unit connector | Terminal | | |
| B142 | 16 | Ground | No |
| | 18 | | |
| | 20 | | |
| | 21 | | |

OK or NG

OK >> GO TO 4.

NG >> Repair or replace harness between pre-crash seat belt control unit and brake pedal stroke sensor.

4. CHECK BRAKE PEDAL STROKE SENSOR POWER SUPPLY

1. Connect pre-crash seat belt control unit connector.
2. Turn the ignition switch ON.
3. Check voltage between pre-crash seat belt control unit harness connector and ground.

| Terminal (+) | | Terminal (-) | Voltage (V) (Approx.) |
|--|----------|--------------|-----------------------|
| Pre-crash seat belt control unit connector | Terminal | | |
| B142 | 18 | Ground | 5 |

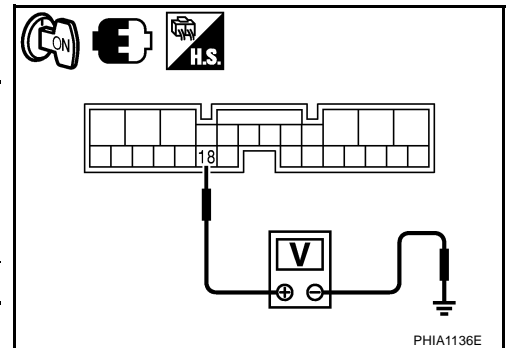

OK or NG

OK >> GO TO 5.

NG >> Replace pre-crash seat belt control unit.

PRE-CRASH SEAT BELT

5. CHECK BRAKE PEDAL STROKE SENSOR

Check continuity between brake pedal stroke sensor while performing brake operation.

| Brake pedal stroke sensor connector | Terminal | | Condition | Resistance (KΩ) (Approx.) |
|-------------------------------------|----------|---|----------------------------|---------------------------|
| E125 | 2 | 1 | Brake released → depressed | 1.0 → 0.2 |
| | | 3 | | 0.2 → 1.0 |

OK or NG

- OK >> Check harness connection.
- If it is OK, replace pre-crash seat belt control unit.
 - If it is NG, repair or replace malfunction part.
- NG >> Replace brake pedal stroke sensor.

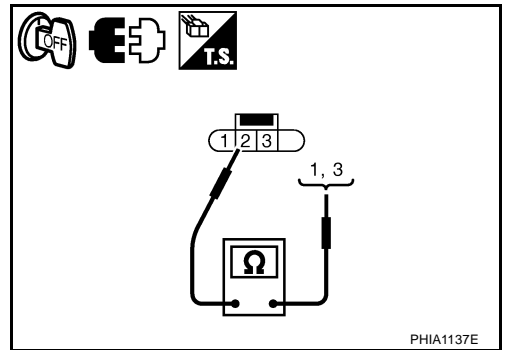

Pre-Crash Seat Belt Motor LH Circuit Check [B2452]

NHS0008E

1. CHECK LH SEAT BELT MOTOR CIRCUIT

Ⓟ With CONSULT-II

Select "SELF-DIAG RESULTS" of CONSULT-II, and then make sure that "SB MOTOR LH CIRC" is displayed.

| CONSULT-II display | CONSULT-II display code |
|--------------------|-------------------------|
| NO DTC | - |
| SB MOTOR LH CIRC | B2452 |

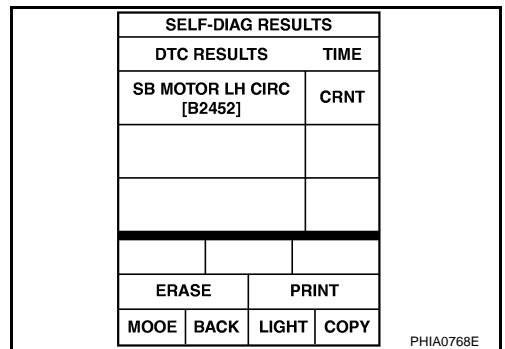

⊗ Without CONSULT-II

When CONSULT-II is not used, omit this inspection, and then GO TO 2.

Displayed B2452?

- Yes >> GO TO 2.
 No >> Pre-crash seat belt motor LH circuit is OK.

PRE-CRASH SEAT BELT

2. CHECK LH SEAT BELT MOTOR HARNESS

1. Turn the ignition switch OFF.
2. Disconnect pre-crash seat belt control unit connector and pre-crash seat belt motor LH connector.
3. Check continuity between pre-crash seat belt control unit harness connector and pre-crash seat belt motor LH harness connector.

| A | | B | | Continuity |
|--|----------|--|----------|------------|
| Pre-crash seat belt control unit connector | Terminal | Pre-crash seat belt motor LH connector | Terminal | |
| B142 | 4 | B32 | 1 | Yes |
| | 6 | | 2 | |

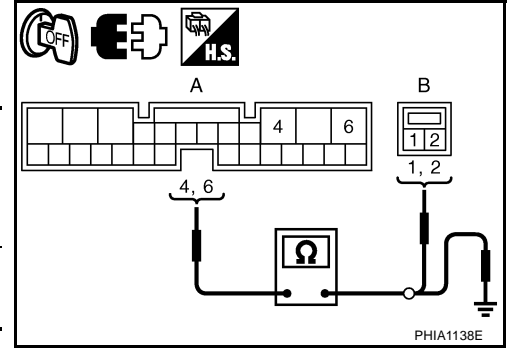

4. Check continuity between pre-crash seat belt control unit harness connector and ground.

| A | | Ground | Continuity |
|--|----------|--------|------------|
| Pre-crash seat belt control unit connector | Terminal | | |
| B142 | 4 | | No |
| | 6 | | |

OK or NG

- OK >> GO TO 3.
 NG >> Repair or replace harness.

3. CHECK SEAT BELT MOTOR

Check continuity between pre-crash seat belt motor LH.

| Pre-crash seat belt motor LH connector | Terminal | | Continuity |
|--|----------|---|------------|
| B32 | 1 | 2 | Yes |

OK or NG

- OK >> Replace pre-crash seat belt control unit.
 NG >> Replace pre-crash seat belt motor LH.

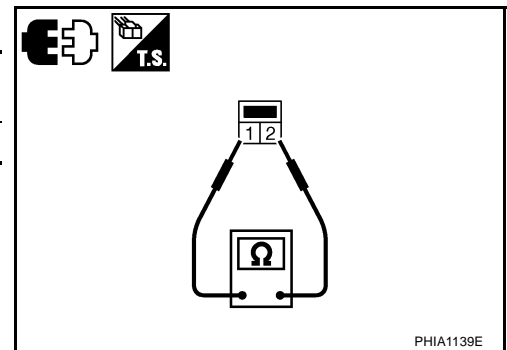

PRE-CRASH SEAT BELT

Pre-Crash Seat Belt Motor RH Circuit Check [B2451]

NHS0008F

1. CHECK RH SEAT BELT MOTOR CIRCUIT

With CONSULT-II

Select "SELF-DIAG RESULTS" of CONSULT-II, and then make sure that "SB MOTOR RH CIRC" is displayed.

| CONSULT-II display | CONSULT-II display code |
|--------------------|-------------------------|
| NO DTC | - |
| SB MOTOR RH CIRC | B2451 |

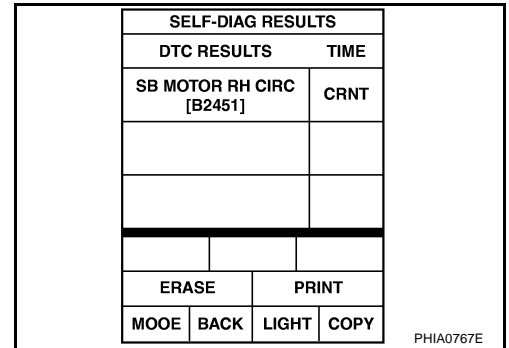

Without CONSULT-II

When CONSULT-II is not used, omit this inspection, and then GO TO 2.

Displayed B2451?

Yes >> GO TO 2.

No >> Pre-crash seat belt motor RH circuit is OK.

2. CHECK RH SEAT BELT MOTOR HARNESS

- Turn the ignition switch OFF.
- Disconnect pre-crash seat belt control unit connector and pre-crash seat belt motor RH connector.
- Check continuity between pre-crash seat belt control unit harness connector and pre-crash seat belt motor RH harness connector.

| A | | B | | Continuity |
|--|----------|--|----------|------------|
| Pre-crash seat belt control unit connector | Terminal | Pre-crash seat belt motor RH connector | Terminal | |
| B142 | 1 | B8 | 2 | Yes |
| | 3 | | 1 | |

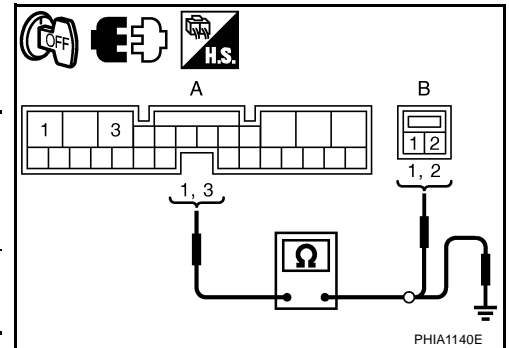

- Check continuity between pre-crash seat belt control unit harness connector and ground.

| A | | Ground | Continuity |
|--|----------|--------|------------|
| Pre-crash seat belt control unit connector | Terminal | | |
| B142 | 1 | | No |
| | 3 | | |

OK or NG

OK >> GO TO 3.

NG >> Repair or replace harness.

PRE-CRASH SEAT BELT

3. CHECK SEAT BELT MOTOR

Check continuity between pre-crash seat belt motor RH.

| Pre-crash seat belt motor RH connector | Terminal | | Continuity |
|--|----------|---|------------|
| | 1 | 2 | |
| B8 | 1 | 2 | Yes |

OK or NG

- OK >> Replace pre-crash seat belt control unit.
- NG >> Replace pre-crash seat belt motor RH.

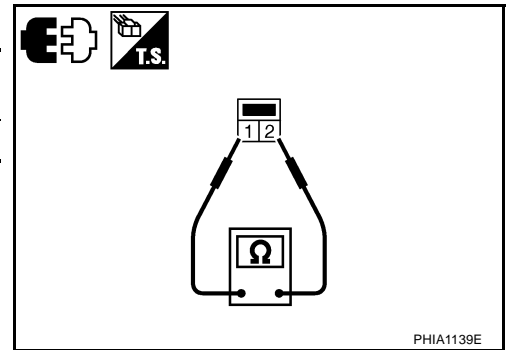

Brake Pedal Stroke Sensor Shield Wire Circuit Check

NHS0008G

1. CHECK PRE-CRASH SEAT BELT INPUT SIGNAL

With CONSULT-II

Select "B PEDAL SIG1 and 2" on DATA MONITOR screen, and then make sure that the voltage does not change if brake pedal is not operated.

NOTE:

Diagnosis should be performed with engine running, audio and air conditioner operating.

B PEDAL SIG1

Brake released :There is no change in the voltage value, and it is almost constant

B PEDAL SIG2

Brake released :There is no change in the voltage value, and it is almost constant.

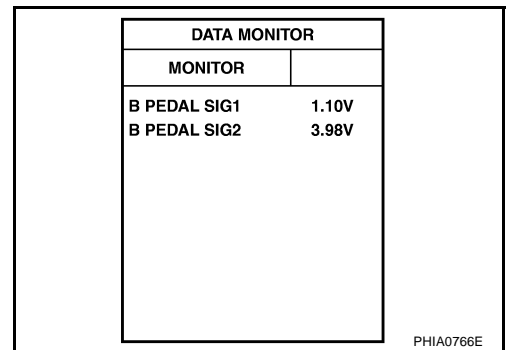

Without CONSULT-II

1. Start engine.
2. Check voltage between pre-crash seat belt harness connector.

| Terminal | | (-) | Condition | Voltage (V) (Approx.) |
|--|----------|--------|--|--|
| (+) | Terminal | | | |
| Pre-crash seat belt control unit connector | 16 | Ground | Performed with engine running, audio and air conditioner operating and brake pedal released. | There is no change in the voltage value, and it is almost constant |
| | 20 | | | |

OK or NG

- OK >> Brake pedal stroke sensor shield wire circuit is OK.
- NG >> Check shield wire for damage. Repair or replace if necessary.

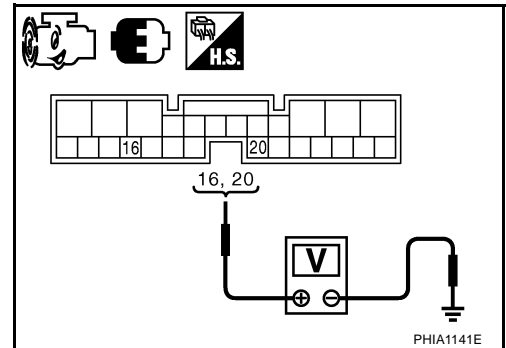

PRE-CRASH SEAT BELT

Removal and Installation of Pre-Crash Seat Belt Control Unit

NHS000BH

REMOVAL

1. Remove trunk side finisher LH. Refer to [EI-56, "Removal and Installation for Trunk Room Trim"](#) .
2. Remove pre-crash seat belt control unit mounting bolts.
3. Remove pre-crash seat belt control unit connector, and the pre-crash seat belt control unit.

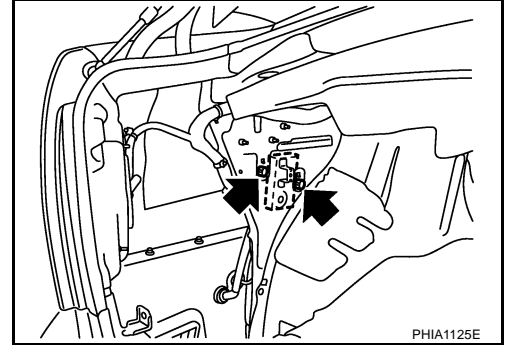

INSTALLATION

Install in the reverse order of removal.

A
B
C
D
E
F
G
SB
I
J
K
L
M

SB

SEAT BELTS

SEAT BELTS

PF:86884

System Description

SEAT BELT WARNING CHIME

NHS0008I

- With ignition switch turned ON and seat belt unfastened (seat belt switch ON), warning chime will sound for approximately 6 seconds.
- If warning chime does not sound, refer to [DI-74, "Seat Belt Buckle Switch Signal Inspection"](#).

SEAT BELT WARNING LAMP

- Fasten driver's seat belt.
- The seat belt warning lamp should go out.
- If the seat belt warning lamp does not go out, refer to [DI-43, "Wiring Diagram — WARN —"](#).

Removal and Installation of Front Seat Belt

NHS0008J

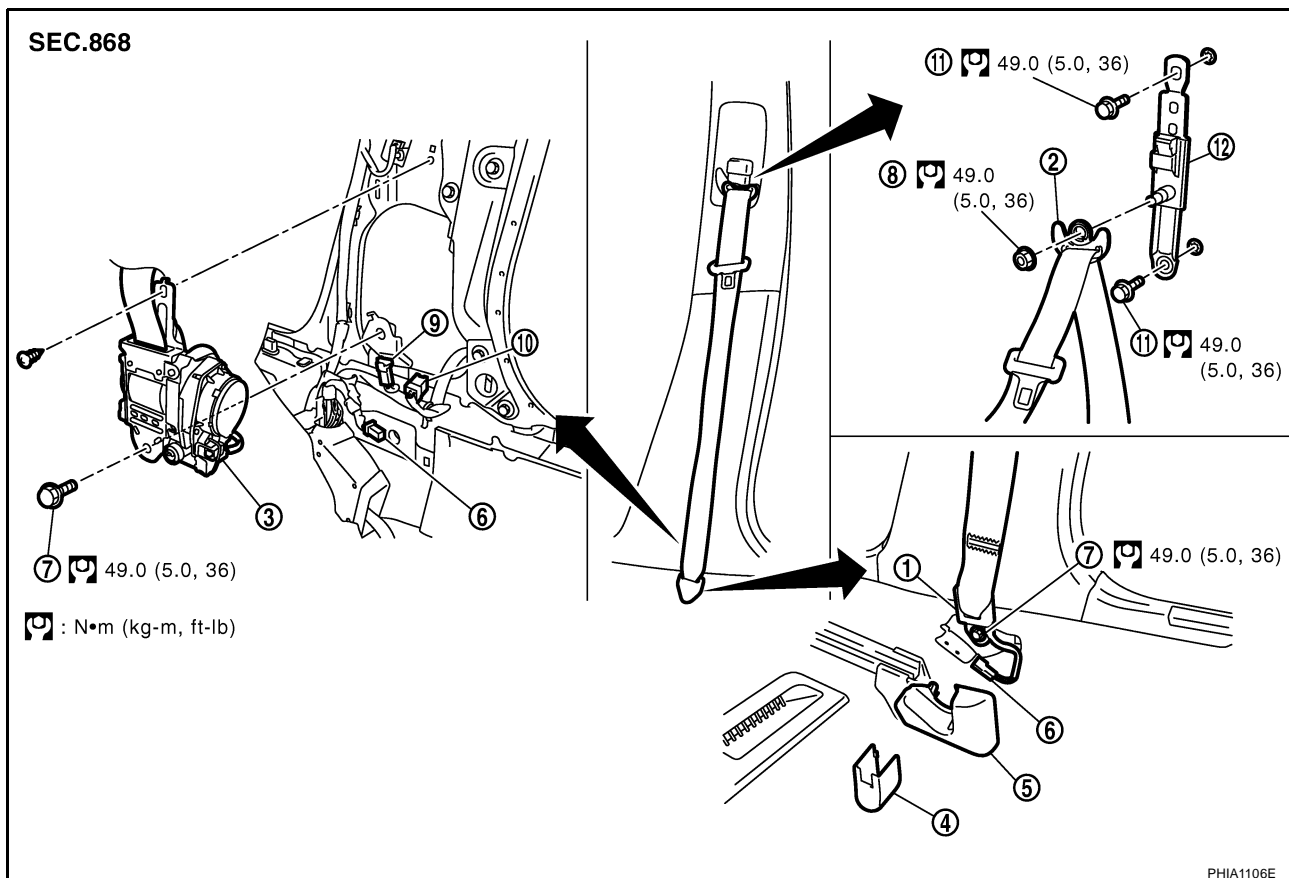

- | | | |
|--|--|--|
| 1. Outer anchor | 2. Shoulder anchor | 3. Pre-tensioner seat belt retractor |
| 4. Belt tension sensor cover (passenger side only) | 5. Cover protector (passenger side only) | 6. Belt tension sensor connector (passenger side only) |
| 7. Anchor bolt | 8. Anchor nut | 9. Seat belt pre-tensioner connector |
| 10. Pre-crash seat belt connector | 11. Bolt | 12. Seat belt adjuster |

CAUTION:

Before servicing SRS, turn the ignition switch off, disconnect both battery cables and wait at least 3 minutes.

REMOVAL OF SEAT BELT RETRACTOR

1. Remove the outer anchor.
 - Remove the belt tension sensor cover and cover protector (passenger side only).
 - Disconnect the belt tension sensor connector (passenger side only).
 - Remove the fixing bolt of the outer anchor.

SEAT BELTS

2. Remove the shoulder anchor.
 - Remove the center pillar lower and upper garnishes, refer to [EI-37, "BODY SIDE TRIM"](#) .
 - Remove the fixing anchor nut of the shoulder anchor.
3. Remove the seat belt assembly.
 - Disconnect the seat belt pre-tensioner connector.

CAUTION:

- For installing/removing seat belt pre-tensioner connector, insert thin screwdriver wrapped in tape into notch, lift lock and remove connector.
- Install connector with lock raised, and push lock into connector.

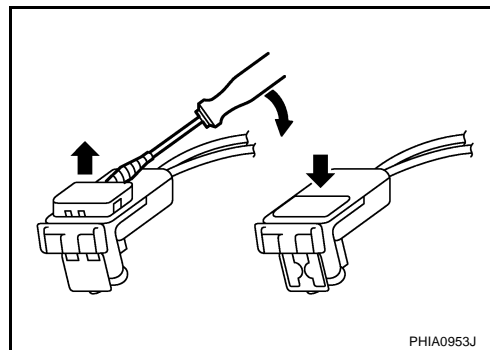

- Disconnect the pre-crush seat belt connector (for only the vehicle with pre-clash seat belt).
- Remove the fixing screw and anchor bolt of the pre-tensioner seat belt retractor.

INSTALLATION OF SEAT BELT RETRACTOR

- Install in the reverse order of removal.
- Tighten by specified torque.

Tightening torque : 49.0 N-m (5.0 kg-m, 36 ft-lb)

REMOVAL OF SEAT BELT BUCKLE

1. Remove the seat belt buckle.
 - Remove the front seat from vehicle, refer to [SE-167, "Removal and Installation"](#) (For ease of tool operation in narrow space).
 - Disconnect the seat belt buckle harness connector.
 - Remove the fixing anchor bolt of the seat belt buckle.

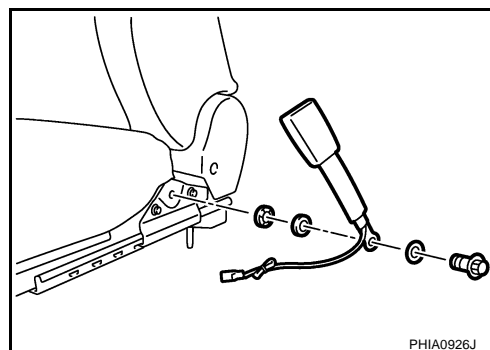

INSTALLATION OF SEAT BELT BUCKLE

- Install in the reverse order of removal.
- Tighten by specified torque.

Tightening torque : 49.0 N-m (5.0 kg-m, 36 ft-lb)

A
B
C
D
E
F
G
SB
I
J
K
L
M

SEAT BELTS

Removal and Installation of Rear Seat Belt

NHS000BK

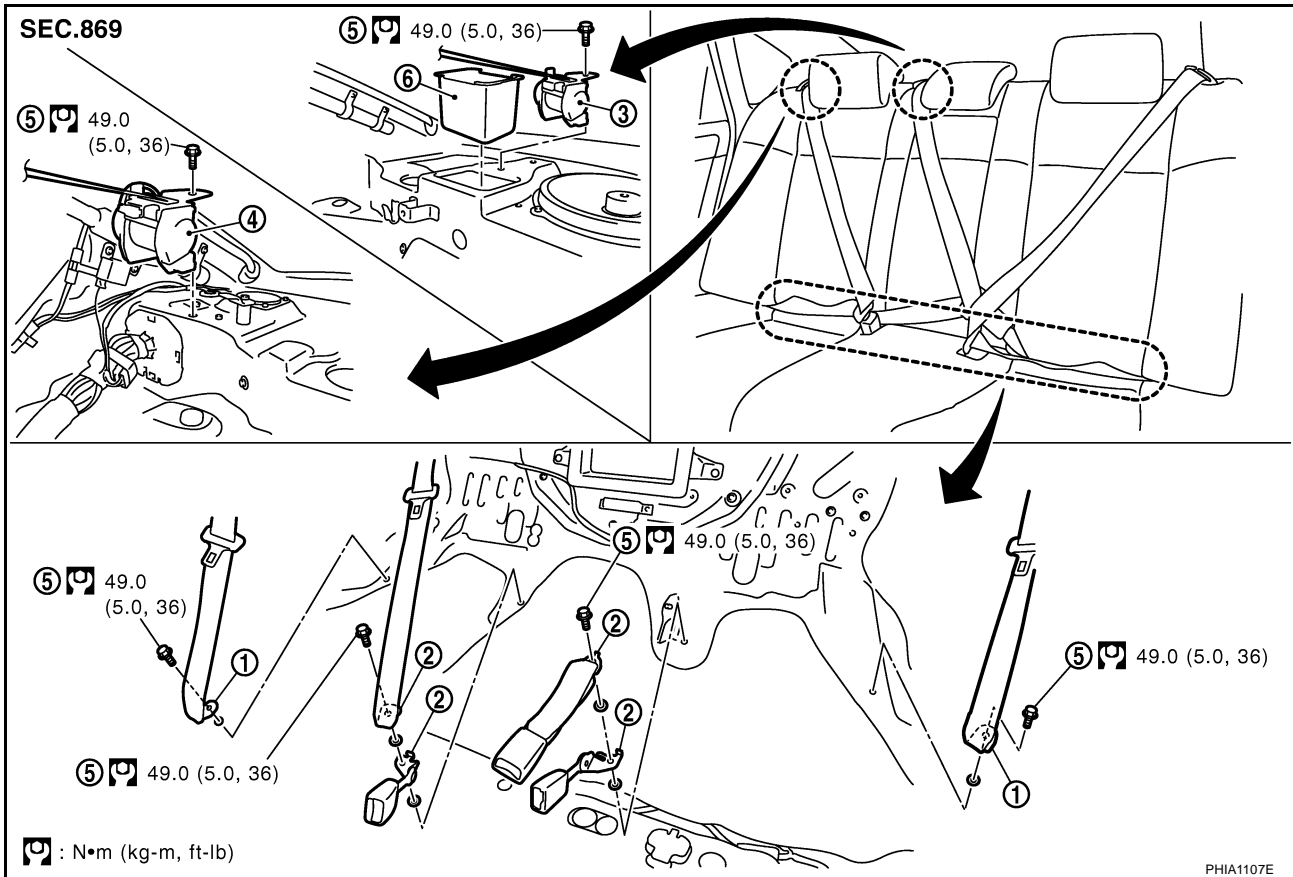

- | | | |
|------------------------------|-----------------|-------------------------------|
| 1. Outer anchor | 2. Inner anchor | 3. Center seat belt retractor |
| 4. Outer seat belt retractor | 5. Anchor bolt | 6. Retractor cover |

REMOVAL OF SEAT BELT RETRACTOR

1. Remove the outer and inner anchors.
 - Remove the rear seat cushion, refer to [SE-176, "Removal and Installation"](#) .
 - Remove the outer anchor fixing anchor bolt and the anchor bolt tightening the inner anchor together with the seat belt buckle.
2. Remove the seat belt assembly.
 - Remove the rear seatback, refer to [SE-176, "Removal and Installation"](#) .
 - Remove the rear kicking plate, the rear wheelhouse garnish and the rear pillar finisher, refer to [EI-37, "BODY SIDE TRIM"](#) .
 - Remove the seat belt finisher from the rear parcel shelf finisher, refer to [EI-42, "REAR PARCEL SHELF FINISHER"](#) .
 - Remove the rear parcel shelf finisher, refer to [EI-42, "REAR PARCEL SHELF FINISHER"](#) .
 - Remove the fixing anchor bolt of the seat belt retractor.

INSTALLATION OF SEAT BELT RETRACTOR

- Install in the reverse order of removal.
- Tighten by specified torque.
Tightening torque : 49.0 N-m (5.0 kg-m, 36 ft-lb)

REMOVAL OF SEAT BELT BUCKLE

1. Remove the seat belt buckle.
 - Remove the rear seat cushion, refer to [SE-176, "Removal and Installation"](#) .
 - Remove the fixing anchor bolt of the inner anchor.

SEAT BELTS

INSTALLATION OF SEAT BELT BUCKLE

- Install in the reverse order of removal.
- Tighten by specified torque.

Tightening torque : 49.0 N-m (5.0 kg-m, 36 ft-lb)

Seat Belt Inspection AFTER A COLLISION

NHS0008L

WARNING:

Inspect all seat belt assemblies including retractors and attaching hardware after any collision. NISSAN / INFINITI recommends that all seat belt assemblies in use during a collision be replaced unless the collision was minor and the belts show no damage and continue to operate properly. Failure to do so could result in serious personal injury in an accident. Seat belt assemblies not in use during a collision should also be replaced if either damage or improper operation is noted. Seat belt pre-tensioned should be replaced even if the seat belts are not in use during a frontal collision in which the air bags are deployed.

Replace any seat belt assembly (including anchor bolts) if:

- The seat belt was in use at the time of a collision (except for minor collisions and the belts, retractors and buckles show no damage and continue to operate properly).
- The seat belt was damaged in an accident. (i.e. torn webbing, bent retractor or guide, etc.)
- The seat belt attaching point was damaged in an accident. Inspect the seat belt attaching area for damage or distortion and repair as necessary before installing a new seat belt assembly.
- Anchor bolts are deformed or worn out.
- The seat belt pre-tensioner should be replaced even if the seat belts are not in use during the collision in which the air bags are deployed.

PRELIMINARY CHECKS

1. Check the seat belt warning lamp/chime for proper operation as follows:
 - a. Switch ignition ON. The seat belt warning lamp should illuminate. Also, the seat belt warning chime should sound for about six seconds.
 - b. Fasten driver's seat belt. The seat belt warning lamp should go out and the chime (if sounding) should stop.
2. If the air bag warning lamp is blinking, conduct self-diagnosis using CONSULT-II, and air bag warning lamp. Refer to [SRS-19, "SRS Operation Check"](#).
3. Check that the seat belt retractor, seat belt anchor and buckle bolts are securely attached.
4. Check the shoulder seat belt guide and shoulder belt height adjuster for front seats. Ensure guide swivels freely and that webbing lays flat and does not bind in guide. Ensure height adjuster operates properly and holds securely.
5. Check retractor operation:
 - a. Fully extend the seat belt webbing and check for twists, tears or other damage.
 - b. Allow the seat belt to retract. Ensure that webbing returns smoothly and completely into the retractor. If the seat belt does not return smoothly, wipe the inside of the loops with a clean paper cloth. Because dirt built up in the loops of the upper anchors can cause the seat belts to retract slowly.
 - c. Fasten the seat belt. Check the seat belt returns smoothly and completely to the retractor. If the webbing does not return smoothly, the cause may be an accumulation of dust or dirt. Use the "SEAT BELT TAPE SET" and perform the following steps.

Inspect the front seat belt though-anchor

 1. Pull the seat belt out to a length of 500 mm (19.69 in) or more.
 2. Use a clip or other device to fix the seat belt at the center pillar webbing opening.
 3. Pass a thin wire through the though-anchor webbing opening. Hold both ends of the wire and pull it tautly while moving it up and down several times along the webbing opening surface to move matter stuck there.
 4. Any dirt that can not be removed with the wire can be removed by cleaning the opening with a clean cloth.
 5. Apply tape at the point where the webbing contacts the though-anchor webbing opening.

SEAT BELTS

NOTE:

Apply the tape so that there is no looseness or wrinkling.

6. Remove the clip fixing the seat belt and check that the webbing returns smoothly.

6. Repeat steps above as necessary to check the other seat belts.

SEAT BELT RETRACTOR ON-VEHICLE CHECK

Emergency Locking Retractors (ELR) and Automatic Locking Retractors (ALR)

NOTE:

All seat belt retractors are of the Emergency Locking Retractors (ELR) type. In an emergency (sudden stop) the retractor will lock and prevent the webbing from extending any further. All 3-point type seat belt retractors except the driver's seat belt also have an Automatic Locking Retractors (ALR) mode. The ALR mode (also called child restraint mode) is used when installing child seats. The ALR mode is activated when the seat belt is fully extended. When the webbing is then retracted partially, the ALR mode automatically locks the seat belt in a specific position so the webbing cannot be extended any further. To cancel the ALR mode, allow the seat belt to fully wind back into the retractor.

Check the seat belt retractors using the following test(s) to determine if a retractor assembly is operating properly.

ELR Function Stationary Check

Grasp the shoulder webbing and pull forward quickly. The retractor should lock and prevent the belt from extending further.

ALR Function Stationary Check

1. Pull out entire length of seat belt from retractor until a click is heard.
2. Retract the webbing partially. A clicking noise should be heard as the webbing retracts indicating that the retractor is in the Automatic Locking Retractors (ALR) mode.
3. Grasp the seat belt and try to pull out the retractor. The webbing must lock and not extend any further. If NG, replace the retractor assembly.
4. Allow the entire length of the webbing to retract to cancel the automatic locking mode.

ELR Function Moving Check

WARNING:

Perform the following test in a safe, open area clear of other vehicles and obstructions (for example, a large, empty parking lot). Road surface must be paved and dry. **DO NOT** perform the following test on wet or gravel roads or on public streets and highways. This could result in an accident and serious personal injury. The driver and passenger must be prepared to brace themselves in the event the retractor does not lock.

1. Fasten driver's seat belt. Buckle a passenger into the seat for the belt that is to be tested.
2. Proceed to the designated safe area.
3. Drive the vehicle at approximately 16 km/h (10 MPH). Notify any passengers of a pending sudden stop and the driver and passenger must be prepared to brace themselves in the event the retractor does not lock, apply brakes firmly and make a very hard stop.

During stop, seat belts should lock and not be extended. If the seat belt retractor assembly does not lock, perform the retractor off-vehicle check.

SEAT BELTS

SEAT BELT RETRACTOR OFF-VEHICLE CHECK (FRONT SEAT BELT)

1. Remove the seat belt retractor.
 - Remove the front seat belt assembly, refer to [SB-30, "Removal and Installation of Front Seat Belt"](#).
2. Slowly pull out webbing while tilting the retractor assembly forward from the mounted position without twisting the retractor assembly as shown in the illustration.
 - A** : The webbing can be pulled out in case the retractor is tilted 15° degree or less.
 - B** : The webbing can't be pulled out in case the retractor is tilted 35° degree or more.
 - A and B show tilting angles.
 - ↶ : Vehicle front.

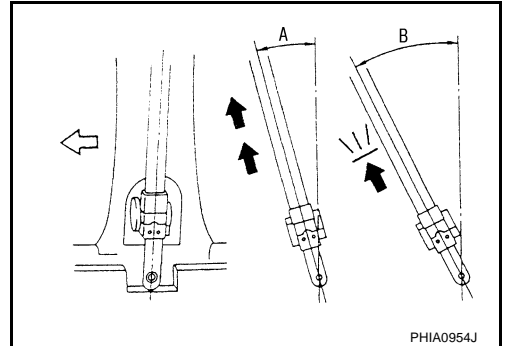

Replace the seat belt assembly if it does not operate normally.

SEAT BELT RETRACTOR OFF-VEHICLE CHECK (REAR SEAT BELT)

1. Remove the seat belt retractor.
 - Remove the front seat belt assembly, refer to [SB-32, "Removal and Installation of Rear Seat Belt"](#).
2. Slowly pull out webbing while tilting the retractor assembly forward from the mounted position without twisting the retractor assembly as shown in the illustration.
 - A** : The webbing can be pulled out in case the retractor is tilted 15° degree or less.
 - B** : The webbing can't be pulled out in case the retractor is tilted 35° degree or more.
 - A and B show tilting angles.
 - ↶ : Vehicle front.

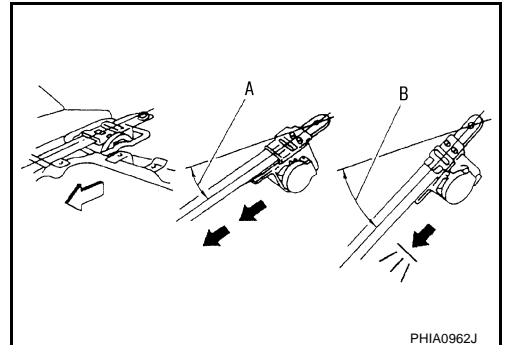

Replace the seat belt assembly if it does not operate normally.

LATCH (LOWER ANCHORS AND TETHER FOR CHILDREN) SYSTEM

LATCH (LOWER ANCHORS AND TETHER FOR CHILDREN) SYSTEM

PFP:75466

Removal and Installation

NHS0008M

CAUTION:

Replace anchor bolts if they are deformed or worn out.

REMOVAL

1. Remove the rear seat. Refer to [SE-176, "Removal and Installation"](#).
2. Remove rear seat frame (Models with rear power seat).
3. Remove LATCH (Lower Anchor and Tether for Children) system.

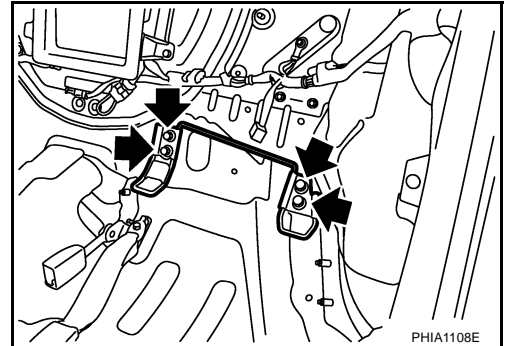

INSTALLATION

- Install in the reverse order of removal.
- Tighten by specified torque.

Tightening torque : 28.0 N-m (2.9 kg-m, 21 ft-lb)

TOP TETHER STRAP CHILD RESTRAINT

TOP TETHER STRAP CHILD RESTRAINT

PFP:88000

Removal and Installation

NHS0008N

CAUTION:

Replace anchor bolts if they are deformed or worn out.

REMOVAL

1. Remove the top tether strap child restraint cover. Refer to [EI-42, "Removal and Installation"](#).
2. Remove the top tether strap child restraint.

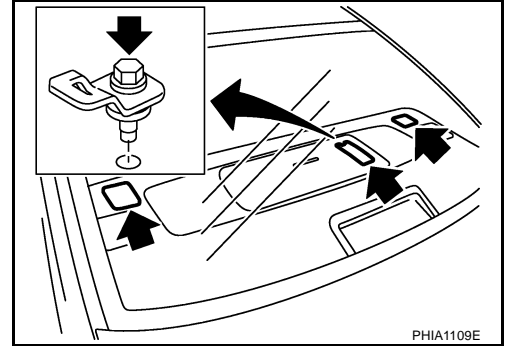

INSTALLATION

- Install in the reverse order of removal.
- Tighten by specified torque.

Tightening torque : 30.0 N-m (3.1 kg-m, 22 ft-lb)

A
B
C
D
E
F
G
I
J
K
L
M

SB

TOP TETHER STRAP CHILD RESTRAINT
