

A
B
C
D
E

SECTION **BR** BRAKE SYSTEM

CONTENTS

<p>PRECAUTIONS 3</p> <p style="padding-left: 20px;">Precautions for Supplemental Restraint System (SRS) "AIR BAG" and "SEAT BELT PRE-TENSIONER" 3</p> <p style="padding-left: 20px;">Precautions for Procedures without Cowl Top Cover... 3</p> <p style="padding-left: 20px;">Precautions for Brake System 3</p> <p>PREPARATION 4</p> <p style="padding-left: 20px;">Commercial Service Tools 4</p> <p>NOISE, VIBRATION AND HARSHNESS (NVH)</p> <p>TROUBLESHOOTING 5</p> <p style="padding-left: 20px;">NVH Troubleshooting Chart 5</p> <p>BRAKE PEDAL 6</p> <p style="padding-left: 20px;">Inspection and Adjustment 6</p> <p style="padding-left: 40px;">ADJUSTMENT 6</p> <p style="padding-left: 20px;">Removal and Installation 7</p> <p style="padding-left: 40px;">COMPONENTS 7</p> <p style="padding-left: 40px;">REMOVAL 8</p> <p style="padding-left: 40px;">INSPECTION AFTER REMOVAL 8</p> <p style="padding-left: 40px;">INSTALLATION 8</p> <p>BRAKE FLUID 9</p> <p style="padding-left: 20px;">On-Board Inspection 9</p> <p style="padding-left: 40px;">CHECKING BRAKE FLUID LEVEL 9</p> <p style="padding-left: 20px;">Checking Brake Line 9</p> <p style="padding-left: 20px;">Drain and Refill 9</p> <p style="padding-left: 20px;">Bleeding Brake System 10</p> <p>BRAKE TUBE AND HOSE 11</p> <p style="padding-left: 20px;">Hydraulic Circuit 11</p> <p style="padding-left: 20px;">Removal and Installation of Front Brake Tube and Brake Hose 12</p> <p style="padding-left: 40px;">REMOVAL 12</p> <p style="padding-left: 40px;">INSTALLATION 12</p> <p style="padding-left: 20px;">Removal and Installation of Rear Brake Tube and Brake Hose 12</p> <p style="padding-left: 40px;">REMOVAL 12</p> <p style="padding-left: 40px;">INSTALLATION 13</p> <p style="padding-left: 20px;">Inspection after Installation 13</p> <p>BRAKE MASTER CYLINDER 14</p> <p style="padding-left: 20px;">On-Board Inspection 14</p> <p style="padding-left: 40px;">LEAK INSPECTION 14</p> <p style="padding-left: 20px;">Removal and Installation 14</p>	<p style="padding-left: 20px;">REMOVAL 14</p> <p style="padding-left: 20px;">INSTALLATION 14</p> <p style="padding-left: 20px;">Disassembly and Assembly 15</p> <p style="padding-left: 40px;">COMPONENTS 15</p> <p style="padding-left: 40px;">DISASSEMBLY 15</p> <p style="padding-left: 40px;">ASSEMBLY 16</p> <p>BRAKE BOOSTER 17</p> <p style="padding-left: 20px;">On-Board Inspection and Service 17</p> <p style="padding-left: 40px;">OPERATION CHECK 17</p> <p style="padding-left: 40px;">AIR TIGHT CHECK 17</p> <p style="padding-left: 20px;">Removal and Installation 18</p> <p style="padding-left: 40px;">COMPONENTS 18</p> <p style="padding-left: 40px;">REMOVAL 18</p> <p style="padding-left: 40px;">INSTALLATION 18</p> <p>VACUUM LINES 20</p> <p style="padding-left: 20px;">Components 20</p> <p style="padding-left: 20px;">Removal and Installation 21</p> <p style="padding-left: 20px;">Inspection 21</p> <p style="padding-left: 40px;">VISUAL INSPECTION 21</p> <p style="padding-left: 40px;">CHECK VALVE INSPECTION 21</p> <p>FRONT DISC BRAKE 22</p> <p style="padding-left: 20px;">On-Board Inspection 22</p> <p style="padding-left: 40px;">PAD WEAR INSPECTION 22</p> <p style="padding-left: 20px;">Components 22</p> <p style="padding-left: 20px;">Removal and Installation of Brake Pad 23</p> <p style="padding-left: 40px;">REMOVAL 23</p> <p style="padding-left: 40px;">INSTALLATION 23</p> <p style="padding-left: 20px;">Removal and Installation of Brake Caliper Assembly</p> <p style="padding-left: 40px;">... 24</p> <p style="padding-left: 40px;">REMOVAL 24</p> <p style="padding-left: 40px;">INSTALLATION 24</p> <p style="padding-left: 20px;">Disassembly and Assembly of Brake Caliper Assembly</p> <p style="padding-left: 40px;">... 25</p> <p style="padding-left: 40px;">DISASSEMBLY 25</p> <p style="padding-left: 40px;">INSPECTION AFTER DISASSEMBLY 25</p> <p style="padding-left: 40px;">ASSEMBLY 26</p> <p style="padding-left: 40px;">DISC ROTOR INSPECTION 27</p> <p style="padding-left: 40px;">BRAKE BURNISHING PROCEDURE 27</p> <p>REAR DISC BRAKE 28</p> <p style="padding-left: 20px;">On-Board Inspection 28</p>
--	--

BR
G
H
I
J
K
L
M

PAD WEAR INSPECTION	28	Assembly	31
Components	28	DISASSEMBLY	31
Removal and Installation of Brake Pad	29	INSPECTION AFTER DISASSEMBLY	31
REMOVAL	29	ASSEMBLY	32
INSTALLATION	29	DISC ROTOR INSPECTION	33
Removal and Installation of Brake Caliper Assembly		BRAKE BURNISHING PROCEDURE	33
... ..	30	SERVICE DATA AND SPECIFICATIONS (SDS)	34
REMOVAL	30	General Specifications	34
INSTALLATION	30	Brake Pedal	34
Disassembly and Assembly of Brake Caliper		Brake Booster	34
		Check Valve	34
		Front Disc Brake	34
		Rear Disc Brake	34

PRECAUTIONS

PRECAUTIONS

PFP:00001

Precautions for Supplemental Restraint System (SRS) "AIR BAG" and "SEAT BELT PRE-TENSIONER"

NFS000RO

The Supplemental Restraint System such as "AIR BAG" and "SEAT BELT PRE-TENSIONER", used along with a front seat belt, helps to reduce the risk or severity of injury to the driver and front passenger for certain types of collision. This system includes seat belt switch inputs and dual stage front air bag modules. The SRS system uses the seat belt switches to determine the front air bag deployment, and may only deploy one front air bag, depending on the severity of a collision and whether the front occupants are belted or unbelted. Information necessary to service the system safely is included in the SRS and SB section of this Service Manual.

WARNING:

- To avoid rendering the SRS inoperative, which could increase the risk of personal injury or death in the event of a collision which would result in air bag inflation, all maintenance must be performed by an authorized NISSAN/INFINITI dealer.
- Improper maintenance, including incorrect removal and installation of the SRS, can lead to personal injury caused by unintentional activation of the system. For removal of Spiral Cable and Air Bag Module, see the SRS section.
- Do not use electrical test equipment on any circuit related to the SRS unless instructed to in this Service Manual. SRS wiring harnesses can be identified by yellow and/or orange harnesses or harness connectors.

Precautions for Procedures without Cowl Top Cover

NFS000RP

When performing the procedure after removing cowl top cover, cover the lower end of windshield with urethane, etc.

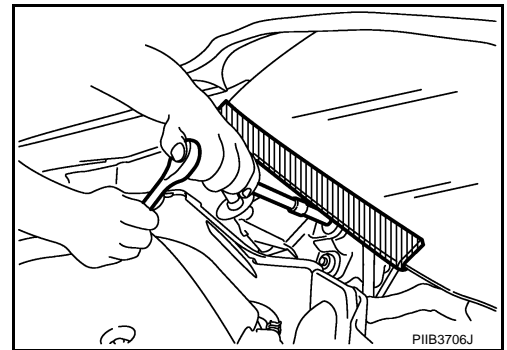

Precautions for Brake System

NFS000RO

- Clean dust on front brake and rear brake with a vacuum dust collector. Do not blow with compressed air.
- Recommended fluid is brake fluid "DOT 3". Refer to [MA-12. "Fluids and Lubricants"](#) .
- Never reuse drained brake fluid.
- Be careful not to splash brake fluid on painted areas; it may cause paint damage. If brake fluid is splashed on painted areas, wash it away with water immediately.
- Use clean brake fluid, to clean or wash all parts of master cylinder and disc brake caliper, etc.
- Never use mineral oils such as gasoline or kerosene. They will ruin rubber parts of the hydraulic system.
- Use flare nut torque wrench when installing brake tube.
- When installing brake tube and hose, be sure to check torque.
- Before working, turn ignition switch OFF and disconnect connectors of ABS actuator and electric unit (control unit) or battery cable from the negative terminal.
- Burnish the brake contact surfaces after refinishing or replacing rotors, after replacing pads, or if a soft pedal occurs at very low mileage. Refer to [BR-27. "BRAKE BURNISHING PROCEDURE"](#) (front disc brake), [BR-33. "BRAKE BURNISHING PROCEDURE"](#) (rear disc brake).

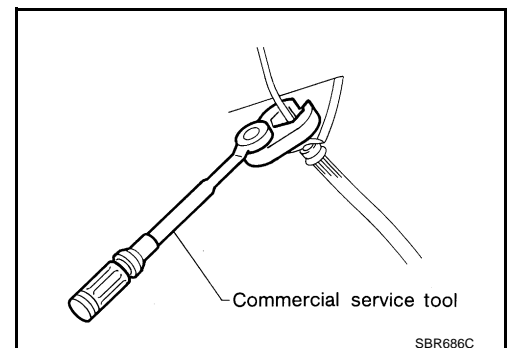

WARNING:

- Clean brake pads and shoes with a waste cloth, then wipe with a dust collector.



PREPARATION

PREPARATION

PFP:00002

Commercial Service Tools

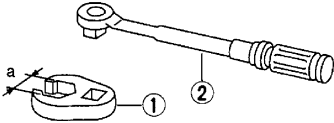
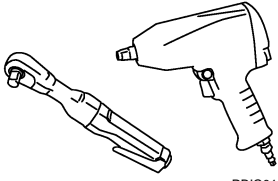
NFS000RR

Tool name	Description
<p>1. Flare nut crowfoot a: 10 mm (0.39 in) / 12 mm (0.47 in)</p> <p>2. Torque wrench</p>	 <p>NT360</p> <p>Installing each brake tube and hose</p>
<p>Power tool</p>	 <p>PBIC0190E</p> <p>Loosening bolts and nuts</p>
<p>Pin punch Tip diameter: 4 mm (0.16in) dia.</p>	 <p>ZZA0515D</p> <p>Removing and installing reservoir tank pin</p>

BRAKE PEDAL

PFP:46501

NFS000RT

BRAKE PEDAL

Inspection and Adjustment

Play and clearance inspection between brake pedal and floor panel with pedal depressed.

- Check brake pedal play.
- Check brake pedal height from dash lower panel (1).
- Adjust height referring to the following specifications.

H1	Brake pedal height [from dash lower panel (1) top surface]	157 – 167 mm (6.18 – 6.57 in)
H2	Depressed brake pedal height [under a force of 490 N (50 kg, 110 lb) with engine running]	90 mm (3.54 in) or more
C	Clearance between threaded end of the stop lamp switch/brake switch (2) and bracket (3)	0.74 – 1.96 mm (0.0291 – 0.0772 in)
A	Pedal play	3 – 11 mm (0.12 – 0.43 in)

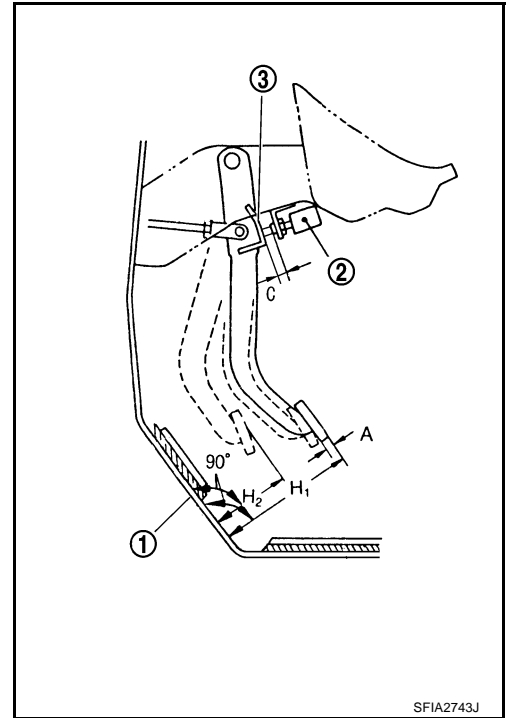

ADJUSTMENT

1. Loosen stop lamp switch and brake switch by turning it counter-clockwise by 45°.
2. Loosen lock nut (A) on the input rod to rotate input rod for adjusting brake pedal height to the specified one, and tighten lock nut (A). Refer to [BR-18, "COMPONENTS"](#).

CAUTION:

Make sure the threaded end of input rod stays inside clevis.

3. With the pedal pulled and held by hand, press stop lamp switch and brake switch until its threaded end contacts stopper.
4. With the threaded end of the stop lamp switch and brake switch contacting the bracket, rotate the switch clockwise by 45° to secure.

CAUTION:

Make sure that the clearance "C" between bracket and end of stop lamp switch and brake switch is within the standard.

5. Check pedal play.

CAUTION:

Make sure that stop lamps goes off when pedal is released.

6. Start engine to check brake pedal depression height when depressed. Refer to [BR-6, "Inspection and Adjustment"](#).

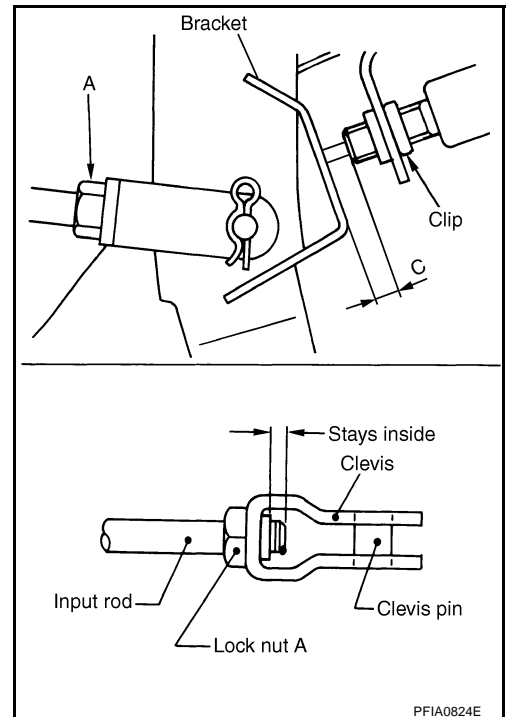

BRAKE PEDAL

NFS000RU

Removal and Installation COMPONENTS

WITHOUT PRE-CRASH SEAT BELT

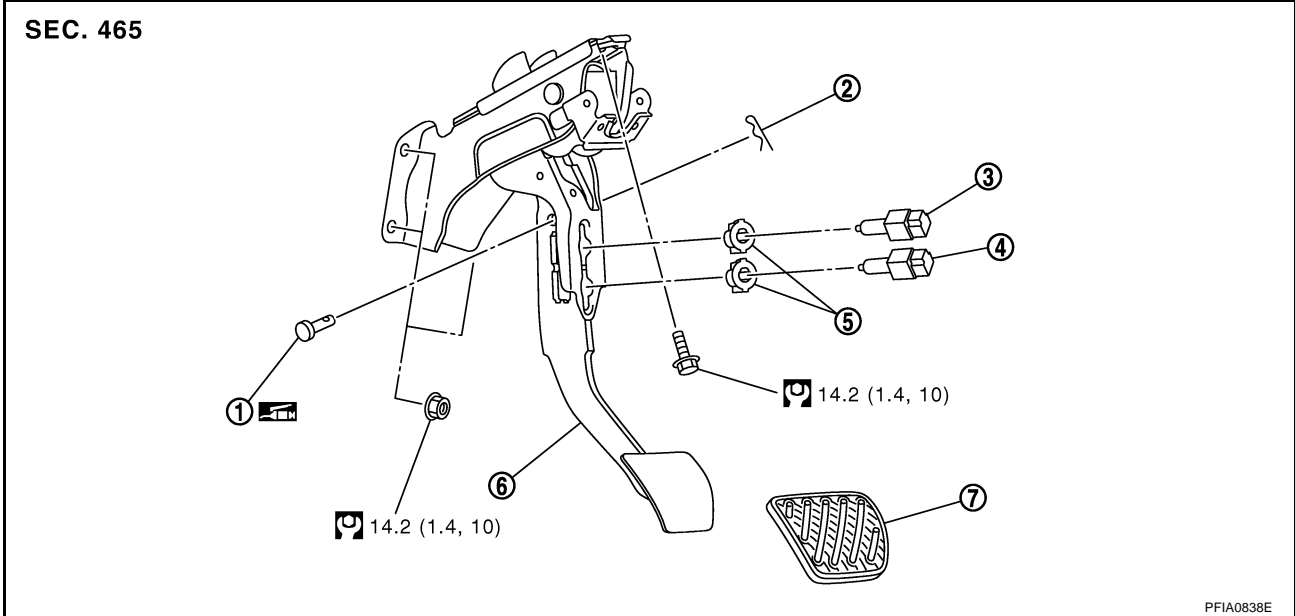

- | | | |
|--------------------|-------------|-------------------------|
| 1. Clevis pin | 2. Snap pin | 3. Stop lamp switch |
| 4. Brake switch | 5. Clip | 6. Brake pedal assembly |
| 7. Brake pedal pad | | |

Refer to [GI-11, "Components"](#) and the followings for the symbols in the figure.

: Apply Multi-purpose grease.

WITH PRE-CRASH SEAT BELT

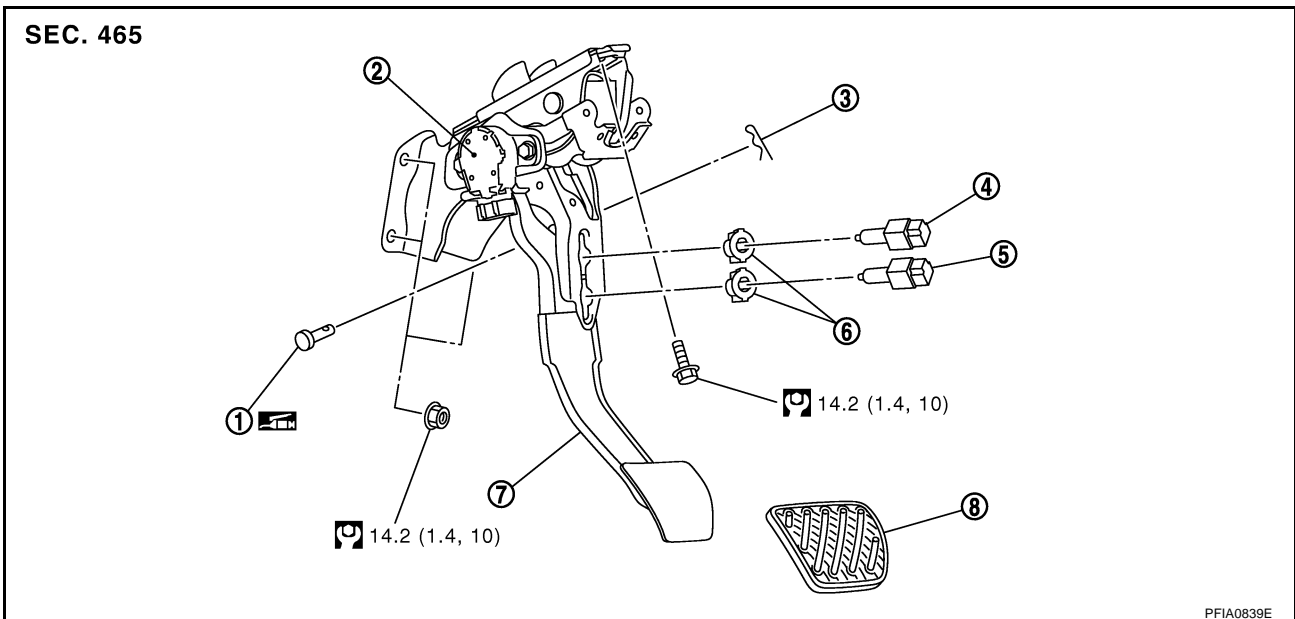

- | | | |
|-------------------------|------------------------------|-------------|
| 1. Clevis pin | 2. Brake pedal stroke sensor | 3. Snap pin |
| 4. Stop lamp switch | 5. Brake switch | 6. Clip |
| 7. Brake pedal assembly | 8. Brake pedal pad | |

Refer to [GI-11, "Components"](#) and the followings for the symbols in the figure.

: Apply Multi-purpose grease.

NOTE:

Clevis pin can be installed from both left and right.

BRAKE PEDAL

REMOVAL

1. Remove instrument driver lower panel. Refer to [IP-10, "INSTRUMENT PANEL ASSEMBLY"](#) .
2. Remove steering column assembly. Refer to [PS-13, "STEERING COLUMN"](#) .
3. Disconnect stop lamp switch and brake switch connector.
4. Remove stop lamp switch and brake switch from brake pedal assembly.
5. Disconnect brake pedal stroke sensor connector.(With pre-crash seat belt)

CAUTION:

Brake pedal stroke sensor is not detachable. Do not detach it.

6. Remove snap pin and clevis pin from clevis of brake booster.
7. Remove brake pedal assembly mounting nuts. Pull brake booster toward engine room to the extent that does not deform brake tube.
8. Remove brake booster clevis from input rod.
9. Remove mounting bolt and then remove brake pedal assembly from vehicle.

INSPECTION AFTER REMOVAL

- Check the items below. If any is found, replace brake pedal assembly.
 - Check brake pedal upper rivet for deformation.
 - Make sure that joint length "L" of sub-bracket and sliding plate is 4 mm (0.16 in) or more.
 - Check brake pedal for bend, damage, and cracks on the welded parts.
- Check clevis pin and plastic stopper for damage and deformation. If any is found, replace clevis pin.

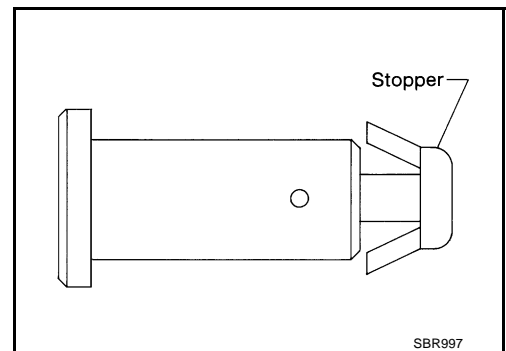
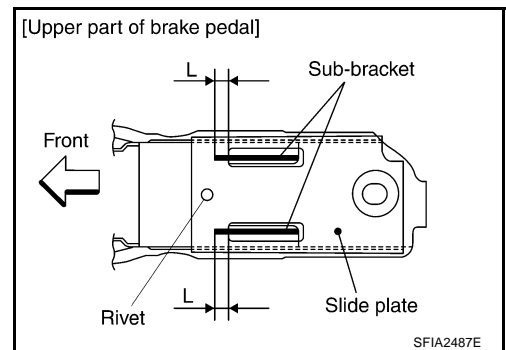

INSTALLATION

Installation is the reverse order of removal. Tightening torques for brake pedal assembly mounting nuts and bolt are referred to [BR-7, "COMPONENTS"](#) . Tightening torque for lock nut is referred to [BR-18, "COMPONENTS"](#) .

- Adjust brake pedal height after installing brake pedal assembly to vehicle. Refer to [BR-6, "Inspection and Adjustment"](#) .

BRAKE FLUID

BRAKE FLUID

PFP:KN100

On-Board Inspection CHECKING BRAKE FLUID LEVEL

NFS000RV

- Make sure that a brake fluid level in reservoir tank is within the standard (between MAX and MIN lines).
- Visually check around reservoir tank for fluid leakage.
- If the level is excessively low, check brake system for leakage.
- Release parking brake pedal and see if brake warning lamp goes off. If not, check brake system for fluid leakage.

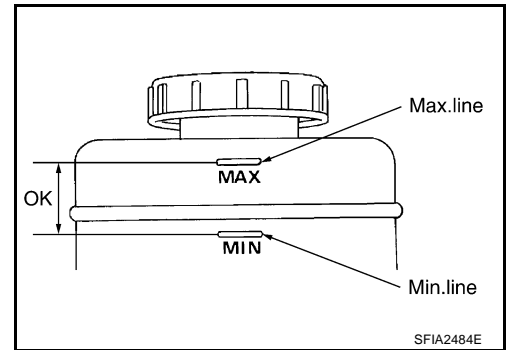

Checking Brake Line

NFS000RW

CAUTION:

If leakage occurs around joints, retighten or, if necessary, replace damaged parts.

1. Check brake line (tubes and hoses) for cracks, deterioration or other damage. Replace any damaged parts.
2. Check for oil leakage by fully depressing brake pedal while engine is running.

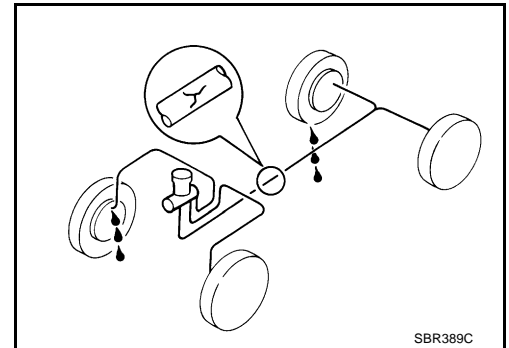

Drain and Refill

NFS000RX

CAUTION:

- Refill with new brake fluid "DOT 3".
 - Never reuse drained brake fluid.
 - Be careful not to splash brake fluid on painted areas; it may cause paint damage. If brake fluid is splashed on painted areas, wash it away with water immediately.
 - Before working, disconnect connectors of ABS actuator and electric unit (control unit) or battery cable from the negative terminal.
1. Connect a vinyl tube to bleed valve.
 2. Depress brake pedal, loosen bleed valve, and gradually remove brake fluid.

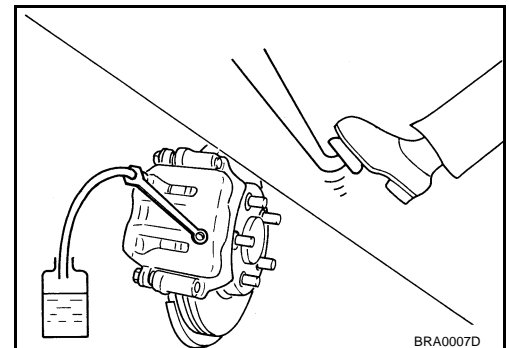

BRAKE FLUID

3. Make sure there is no foreign material in the reservoir tank, and refill with new brake fluid.
4. Loosen bleed valve, depress brake pedal slowly to full stroke and then release it. Repeat the procedure every 2 or 3 seconds until the new brake fluid comes out, then close the bleed valve while depressing the pedal. Repeat the same work for each wheel.
5. Bleed air. Refer to [BR-10, "Bleeding Brake System"](#) .

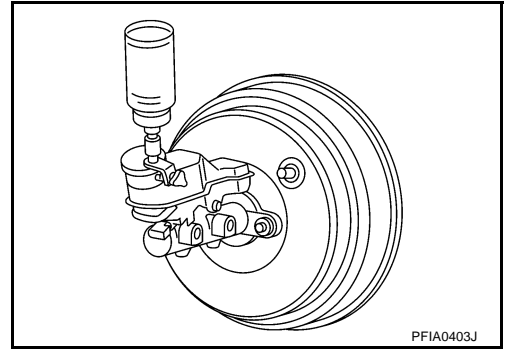

Bleeding Brake System

NFS000RY

CAUTION:

- While bleeding, pay attention to master cylinder fluid level.
 - Before working, disconnect connectors of ABS actuator and electric unit (control unit) or battery cable from the negative terminal.
1. Connect a vinyl tube to rear right brake caliper bleed valve.
 2. Fully depress brake pedal 4 or 5 times.
 3. With brake pedal depressed, loosen bleed valve to bleed air in brake line, and then tighten it immediately.
 4. Repeat steps 2 and 3 until all of the air is out of the brake line.
 5. Tighten the bleed valve to the specified torque. Refer to front disc brake: [BR-22, "Components"](#) , rear disc brake: [BR-28, "Components"](#) .
 6. From step 1 to 5, with master cylinder reservoir tank filled at least half way, bleed air from brake hydraulic line bleed valves in the following order:
Rear right brake→Front left brake→Rear left brake→Front right brake

BRAKE TUBE AND HOSE

BRAKE TUBE AND HOSE

PPF:46300

Hydraulic Circuit

NFS000RZ

A
B
C
D
E
BR
G
H
I
J
K
L
M

SEC. 462

A

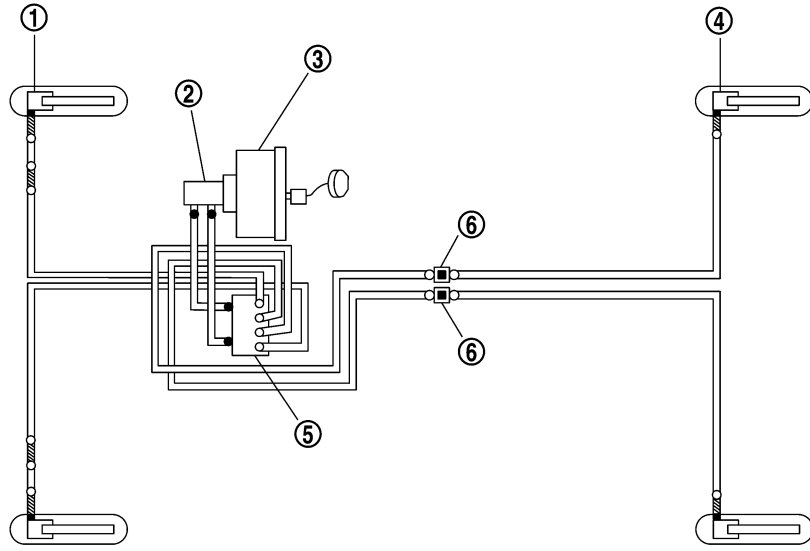

▨ : ⑦
= : ⑧

B

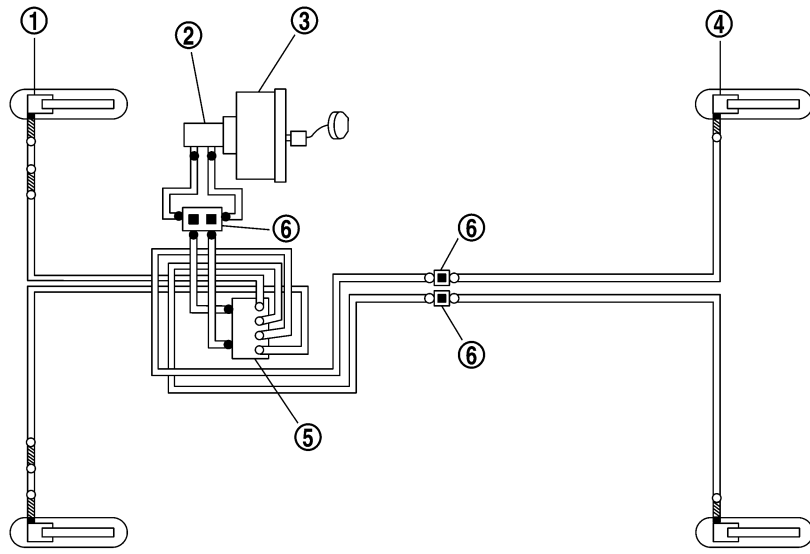

▨ : ⑦
= : ⑧

①

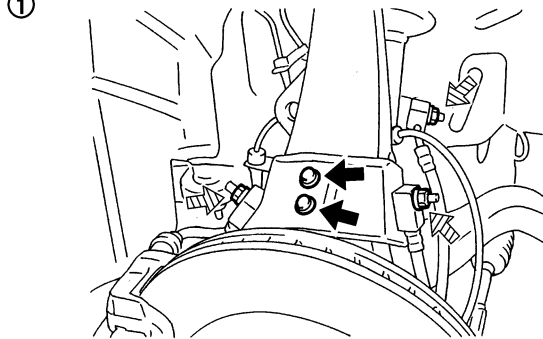

↑ : ⑨ 21.6 (2.2, 16)
← : ⑨ 13.2 (1.3, 10)

④

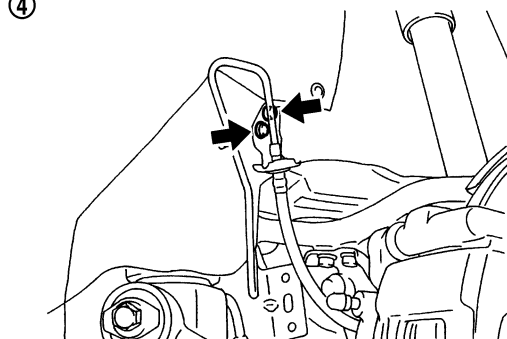



← : ⑨ 28.0 (2.9, 21)

SFIA3096E

BRAKE TUBE AND HOSE

- | | | |
|--|------------------|---------------------|
| A. With out ICC | B. With ICC | 1. Front disc brake |
| 2. Master cylinder | 3. Brake booster | 4. Rear disc brake |
| 5. ABS actuator and electric unit (control unit) | 6. Connector | 7. Brake hose |
| 8. Brake tube | | |

● : Flare nut : 18.2 N·m (1.9 kg·m, 13 ft·lb)

○ : Flare nut : 16.2 N·m (1.7 kg·m, 12 ft·lb)

■ : Union bolt : 18.2 N·m (1.9 kg·m, 13 ft·lb)

■ : Connector mounting bolt : 7.0 N·m (0.7 kg·m, 62 in·lb)

Refer to [GI-11, "Components"](#) , for the symbols in the figure.

CAUTION:

- All brake hoses and tubes must be free from excessive bending, twisting and pulling.
- Make sure that there is no interference with other parts when turning steering both clockwise and counterclockwise.
- Brake tubes and hoses are an important safety part. Always disassemble the parts and retighten their fittings, if a brake fluid leak is detected. Replace applicable part with a new one, if damaged part is detected.
- Be careful not to splash brake fluid on painted areas; it may cause paint damage. If brake fluid is splashed on painted areas, wash it away with water immediately.
- Cover the open end of brake tubes and hoses when disconnecting to prevent entrance of dirt.
- Refill with new brake fluid "DOT 3".
- Never reuse drained brake fluid.

Removal and Installation of Front Brake Tube and Brake Hose

NFS000S0

REMOVAL

1. Drain brake fluid. Refer to [BR-9, "Drain and Refill"](#) .
2. Disconnect brake hose from brake tube, using a flare nut wrench.
3. Remove union bolt and remove brake hose from caliper assembly.
4. Remove lock plate and remove brake hose from vehicle.

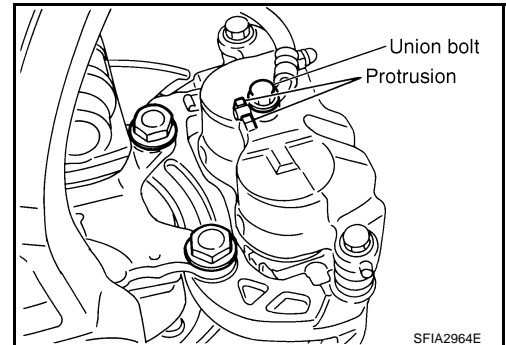

INSTALLATION

1. Assemble the union bolt and copper washer to the brake hose.

CAUTION:

Do not reuse copper washer.

2. Install brake hose by aligning with the protrusion on brake caliper assembly, and tighten union bolt to the specified torque. Refer to [BR-11, "Hydraulic Circuit"](#) .
3. Connect brake hose to brake tube, partially tighten flare nut by hand as much as possible, then secure it to the bracket with lock plate.
4. Using a flare nut torque wrench, tighten flare nut to the specified torque. Refer to [BR-11, "Hydraulic Circuit"](#) .
5. Refill brake fluid and bleed air. Refer to [BR-10, "Bleeding Brake System"](#) .

Removal and Installation of Rear Brake Tube and Brake Hose

NFS000S1

REMOVAL

1. Drain brake fluid. Refer to [BR-9, "Drain and Refill"](#) .

BRAKE TUBE AND HOSE

2. Disconnect brake hose from brake tube, using a flare nut wrench.
3. Remove union bolts, and then remove brake hose from brake caliper assembly.
4. Remove lock plate and then remove brake hose from vehicle.

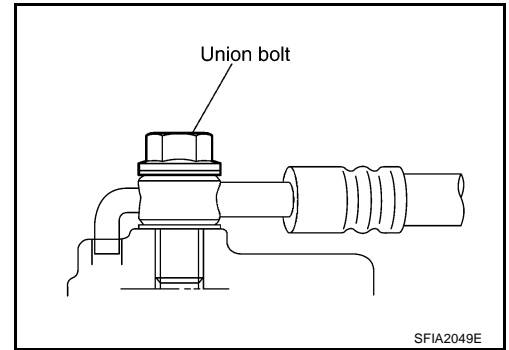

INSTALLATION

1. Assemble the union bolt and copper washer to the brake hose.
CAUTION:
Do not reuse copper washer.
2. Attach L-shape metal fitting of the brake hose to brake caliper assembly positioning hole, and then tighten union bolt to the specified torque. Refer to [BR-11, "Hydraulic Circuit"](#).
3. Connect brake hose to brake tube, partially tighten flare nut by hand as much as possible, then secure it to the bracket with lock plate.
4. Using a flare nut torque wrench, tighten flare nut to the specified torque. Refer to [BR-11, "Hydraulic Circuit"](#).
5. Refill brake fluid and bleed air. Refer to [BR-10, "Bleeding Brake System"](#).

Inspection after Installation

NFS000S2

CAUTION:

Brake tubes and hoses are important safety parts. Always disassemble the parts and retighten their fittings, if a brake fluid leak is detected. Replace applicable part with a new one, if damaged part is detected.

1. Check brake lines (tubes and hoses) and connections for fluid leakage, damage, twists, deformation, contacts with other parts, and loose connections. Replace any damage parts.
2. While depressing brake pedal under a force of 785 N (80 kg, 177 lb) with engine running for approximately 5 seconds, then check each part for fluid leakage.

BRAKE MASTER CYLINDER

BRAKE MASTER CYLINDER

PFP:46010

On-Board Inspection LEAK INSPECTION

NFS000S3

- Check for leaking in a master cylinder installation surface, a reservoir tank installation surface, and brake tube connections.

Removal and Installation

NFS000S4

CAUTION:

- Be careful not to splash brake fluid on painted areas; it may cause paint damage. If brake fluid is splashed on painted areas, wash it away with water immediately.
- Never scratch the piston of master cylinder when installing/removing because the piston is exposed. Check if any dust is not on the piston, and wash with brake fluid if needed.
- Hold cylinder body when handing master cylinder. Never hold the piston because the piston might be detached if pulled strongly.

REMOVAL

1. Drain brake fluid. Refer to [BR-9, "Drain and Refill"](#) .
2. Disconnect brake fluid level switch harness connector.
3. Disconnect master cylinder brake tubes, using a flare nut wrench.
4. Remove master cylinder mounting nuts and remove master cylinder assembly from vehicle.

INSTALLATION

CAUTION:

- Refill with new brake fluid "DOT 3".
 - Never reuse drained brake fluid.
1. Installation is in the reverse order of removal.

CAUTION:

Apply silicone grease to brake booster (to "A" position in the figure) when installing master cylinder to brake booster.

2. Tighten brake tube flare nut to the specified torque using a flare nut torque wrench. Refer to [BR-11, "Hydraulic Circuit"](#) .
3. Refill with new brake fluid and bleed air. Refer to [BR-10, "Bleeding Brake System"](#) .

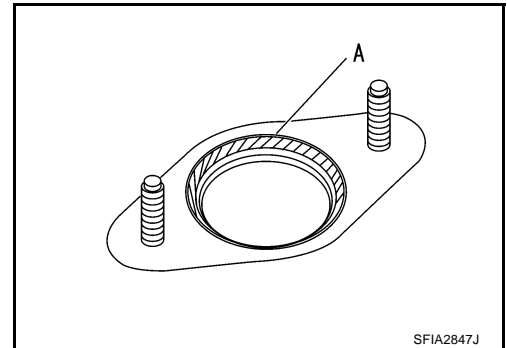

SF1A2847J

BRAKE MASTER CYLINDER

NFS000S5

Disassembly and Assembly COMPONENTS

A
B
C
D
E
BR
G
H
I
J
K
L
M

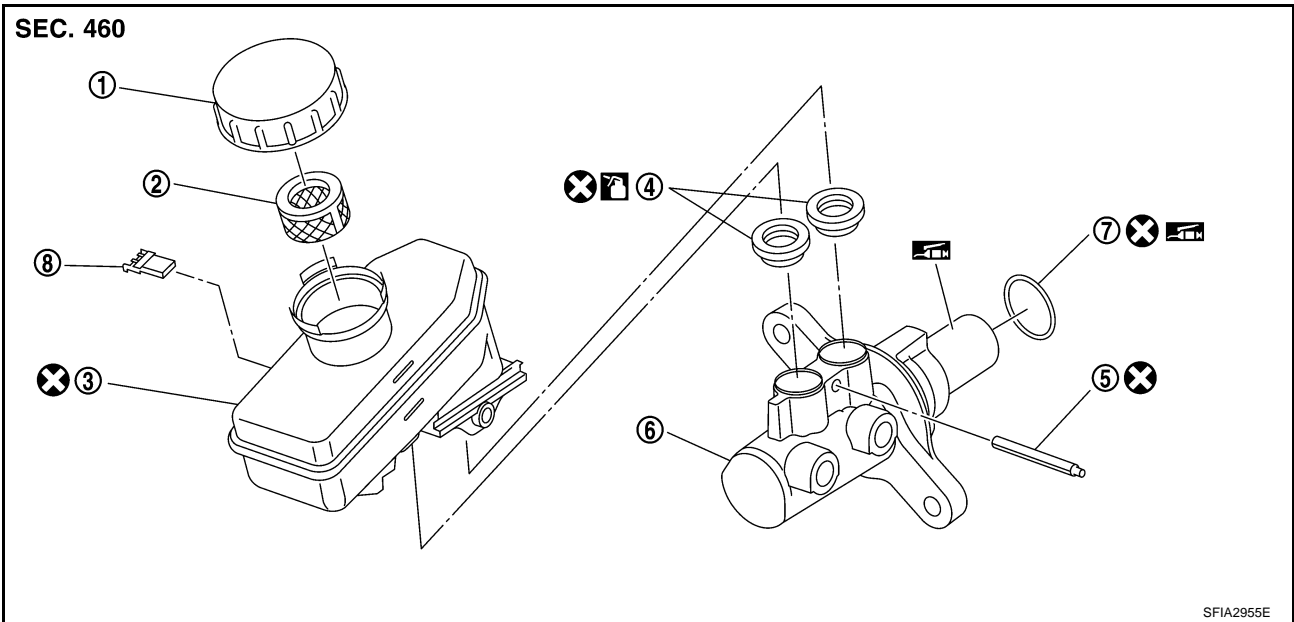

- | | | |
|------------------|---------------------------------------|-----------------------------|
| 1. Reservoir cap | 2. Oil strainer | 3. Reservoir tank |
| 4. Grommet | 5. Pin | 6. Master cylinder assembly |
| 7. O-ring | 8. Brake fluid level switch connector | |

Refer to [GI-11. "Components"](#) and the followings for the symbols in the figure.

 : Apply PBC (Poly Butyl Cuprysil) grease or silicone-based grease.

 : Apply brake fluid.

DISASSEMBLY

CAUTION:

- Master cylinder cannot be disassembled.
- Remove reservoir tank only when absolutely necessary.
- When securing master cylinder assembly in a vise, be sure not to over-tighten.
- When securing in a vise use copper plates or cloth to protect the flange.

1. Using a pin punch [commercial service tool: diameter approximately 4 mm (0.16 in)], remove mounting pin on reservoir tank.
2. Remove reservoir tank and grommet from cylinder body.

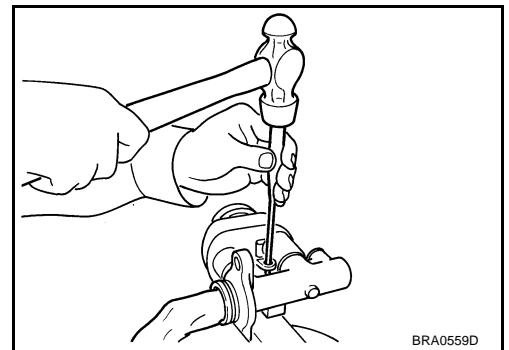

BRAKE MASTER CYLINDER

ASSEMBLY

CAUTION:

- Never use mineral oils such as kerosene, gasoline during the cleaning and assembly process.
 - Do not drop parts. If a part is dropped, do not use it.
1. Apply brake fluid to the grommet and attach it to the cylinder body.

CAUTION:

Do not reuse grommet.

2. Install reservoir tank onto the cylinder body.
3. Secure master cylinder assembly into a vise with a chamfered pin insert hole on cylinder body facing upward.

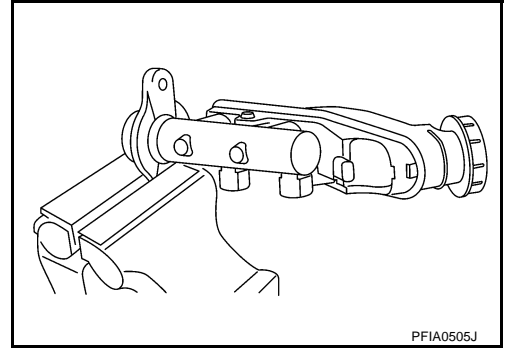

4. Tilt reservoir tank as shown in the figure and insert mounting pin. Return reservoir tank to a upright position when mounting pin passes through the pinhole in the cylinder body. Push the mounting pin to the opposite pinhole of the reservoir tank so that it is the same conditions as the insertion side.

CAUTION:

- Be sure to fix the flange part with the brake tube installation side of cylinder body up.
- Do not reuse mounting pin.

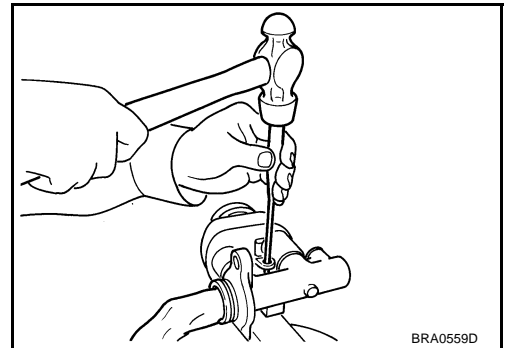

BRAKE BOOSTER

BRAKE BOOSTER

PFP:47200

On-Board Inspection and Service OPERATION CHECK

NFS000S7

With engine stopped, change vacuum to atmospheric pressure by depressing brake pedal several times. Then with brake pedal fully depressed, start engine and when vacuum pressure reaches the standard, make sure that clearance between brake pedal and floor panel decreases.

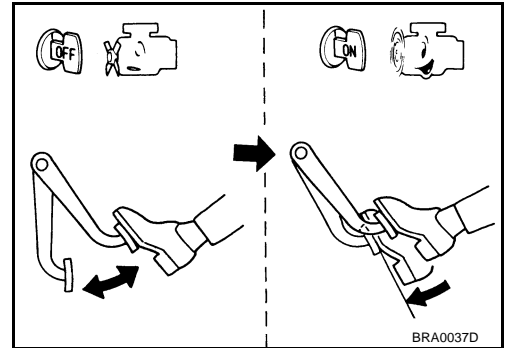

AIR TIGHT CHECK

- Run engine at idle for approximately 1 minute, and stop it after applying vacuum to booster. Depress brake pedal normally to change vacuum to atmospheric pressure. Make sure that distance at intervals of 5 seconds between brake pedal and floor panel gradually increases.
- Depress brake pedal while engine is running, and stop engine with pedal depressed. The pedal stroke should not change after holding pedal down for 30 seconds.

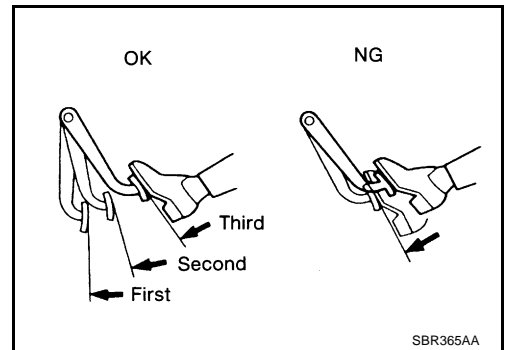

A
B
C
D
E
BR
G
H
I
J
K
L
M

BRAKE BOOSTER

NFS000S8

Removal and Installation COMPONENTS

SEC. 460 • 470

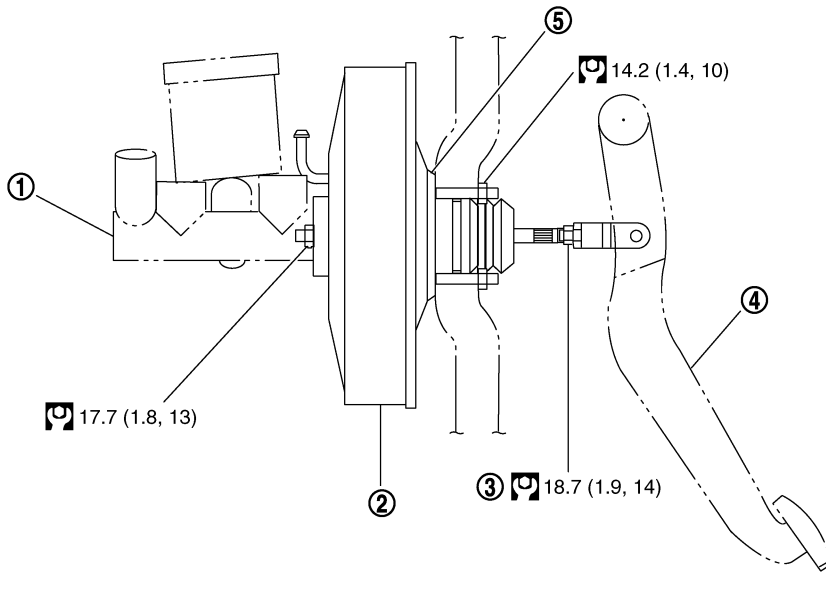

- | | | |
|-----------------------------|------------------|-------------|
| 1. Master cylinder assembly | 2. Brake booster | 3. Lock nut |
| 4. Brake pedal | 5. Gasket | |

Refer to [GI-11, "Components"](#), for the symbols in the figure.

CAUTION:

- Be careful not to deform or bend brake tube while removing and installing brake booster.
- Replace clevis pin if it is damaged.
- Be careful not to damage brake booster stud bolt threads. If brake booster is tilted during installation, the dash panel may damage the threads.

REMOVAL

1. Remove cowl top. Refer to [EI-18, "Removal and Installation"](#).
2. Remove brake master cylinder. Refer to [BR-14, "Removal and Installation"](#).
3. Disconnect front left brake tube from ABS actuator and electric unit (control unit). Refer to [BR-11, "Hydraulic Circuit"](#).
4. Remove vacuum hose from brake booster. Refer to [BR-20, "Components"](#).
5. Remove snap pin and clevis pin from inside vehicle.
6. Remove nuts on brake booster and brake pedal assembly.
7. Remove brake booster from dash panel in engine room side.

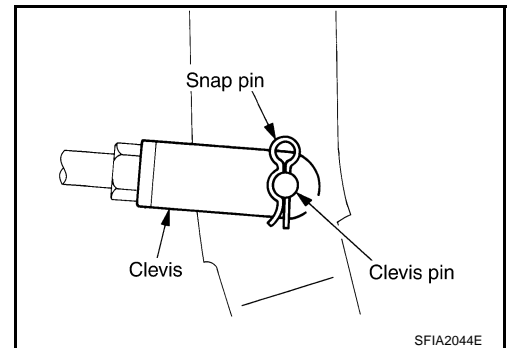

INSTALLATION

1. Loosen lock nut to adjust input rod length so that length "B" (in the figure) satisfies the specified value.

Length "B" : 125 mm (4.92 in)

2. After adjusting "B", temporarily tighten lock nut to install booster assembly to vehicle. At this time, make sure that a gasket between booster assembly and dash panel is installed.

CAUTION:

Always install gasket between brake booster and dash panel.

3. Connect brake pedal with clevis of input rod.

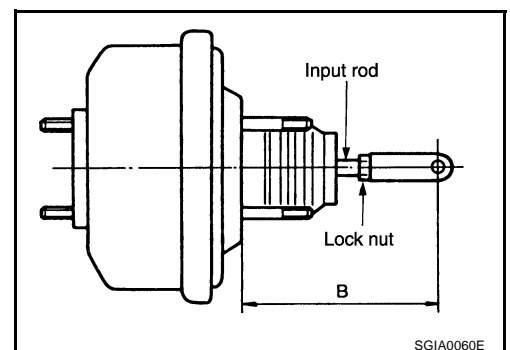

BRAKE BOOSTER

4. Install brake pedal bracket mounting nuts and bolt, and tighten them to the specified torque. Refer to [BR-7, "COMPONENTS"](#) .
5. Install vacuum hose into brake booster. Refer to [BR-21, "Removal and Installation"](#) .
6. Install master cylinder to booster assembly. Refer to [BR-14, "Removal and Installation"](#) .
7. Adjust the brake pedal height and the play of the brake pedal. Refer to [BR-6, "ADJUSTMENT"](#) .
8. Tighten lock nut of input rod to the specified torque. Refer to [BR-18, "COMPONENTS"](#) .
9. Connect front left brake tube to ABS actuator and electric unit (control unit). Refer to [BR-11, "Hydraulic Circuit"](#) .
10. Install cowl top. Refer to [EI-18, "Removal and Installation"](#) .
11. Refill new brake fluid and bleed air. Refer to [BR-10, "Bleeding Brake System"](#) .

A

B

C

D

E

BR

G

H

I

J

K

L

M

VACUUM LINES

VACUUM LINES

PFP:41920

Components

NFS000S9

VK45DE ENGINE MODELS

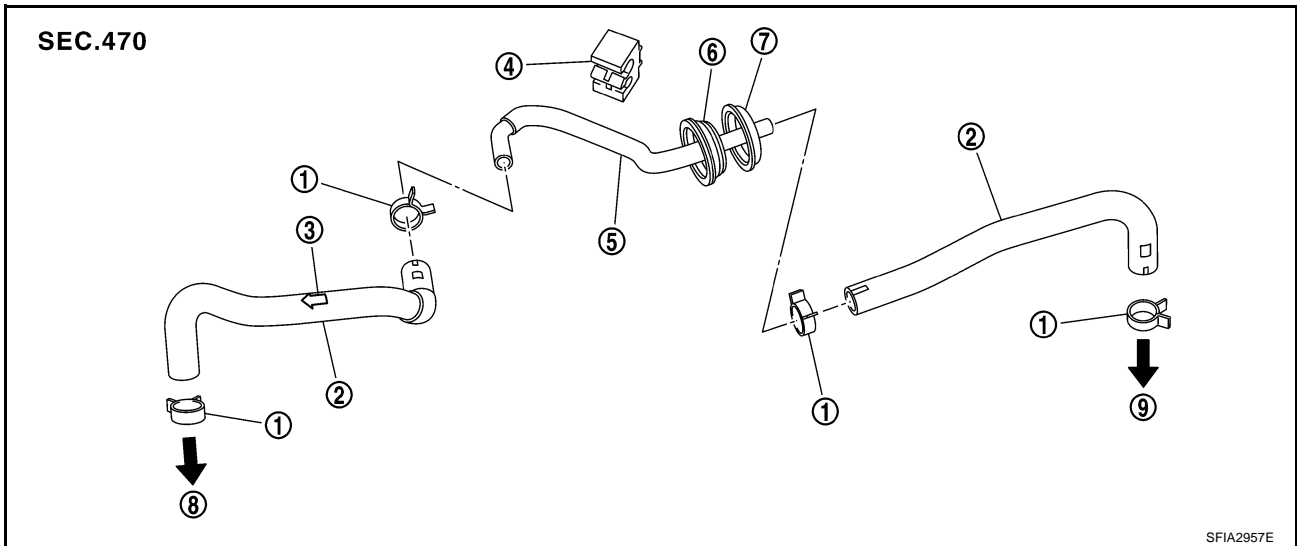

- | | | |
|---------------------------------|------------------------|---|
| 1. Clamp | 2. Vacuum hose | 3. Engine direction indicator stamp
(Built in check valve) |
| 4. Clip | 5. Vacuum piping | 6. Grommet (Vacuum hose side) |
| 7. Grommet (Cowl top assy side) | 8. For intake manifold | 9. For brake booster |

VQ35DE ENGINE MODELS

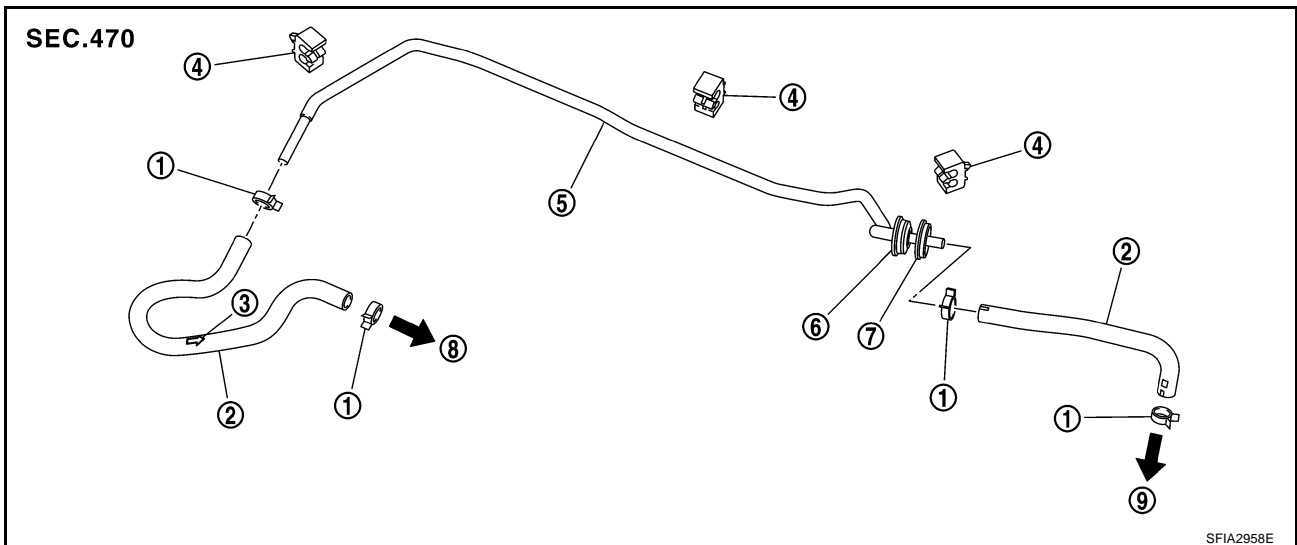

- | | | |
|---------------------------------|------------------------|---|
| 1. Clamp | 2. Vacuum hose | 3. Engine direction indicator stamp
(Built in check valve) |
| 4. Clip | 5. Vacuum piping | 6. Grommet (Vacuum hose side) |
| 7. Grommet (Cowl top assy side) | 8. For intake manifold | 9. For brake booster |

VACUUM LINES

Removal and Installation

NFS000SA

CAUTION:

- Because vacuum hose contains a check valve, it must be installed in the correct position. Refer to the stamp to confirm correct installation. Brake booster will not operate normally if the hose is installed in the wrong direction.
- Insert vacuum hose at least 24 mm (0.94 in).
- Do not use lubricating oil during assembly.

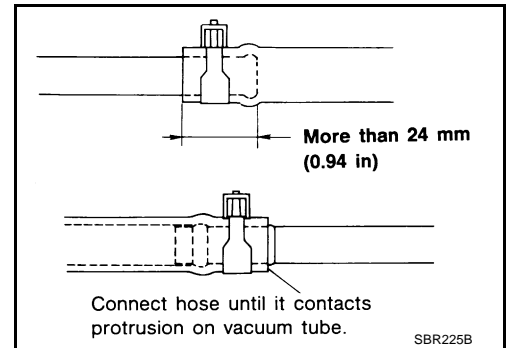

Inspection

VISUAL INSPECTION

Check for correct assembly, damage and deterioration.

CHECK VALVE INSPECTION

Airtightness Inspection

Use a handy vacuum pump to check.

When connected to the booster side (1):

Vacuum should decrease within 1.3 kPa (10 mmHg, 0.39 inHg) for 15 seconds under a vacuum of -66.7 kPa (-500 mmHg, -19.69 inHg).

When connected to the engine side (2):

Vacuum should not exist.

- Replace vacuum hose assembly if vacuum hose and check valve are malfunctioning.

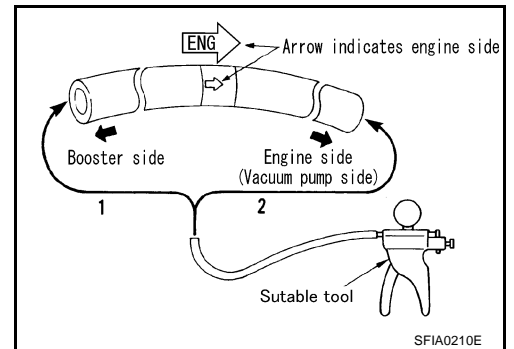

FRONT DISC BRAKE

FRONT DISC BRAKE

PFP:41000

On-Board Inspection PAD WEAR INSPECTION

NFS000SC

- Check pad thickness from an inspection hole on cylinder body. Check using a scale if necessary.

Standard thickness : 11.0 mm (0.433 in)

Repair limit thickness : 2.0 mm (0.079 in)

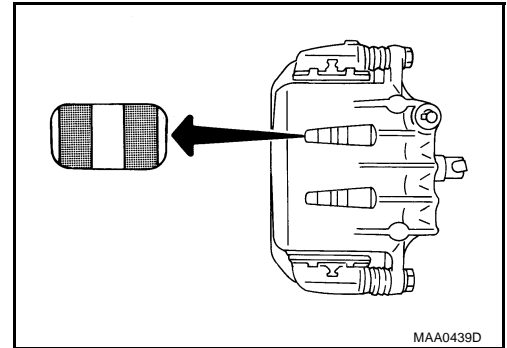

Components

NFS000SD

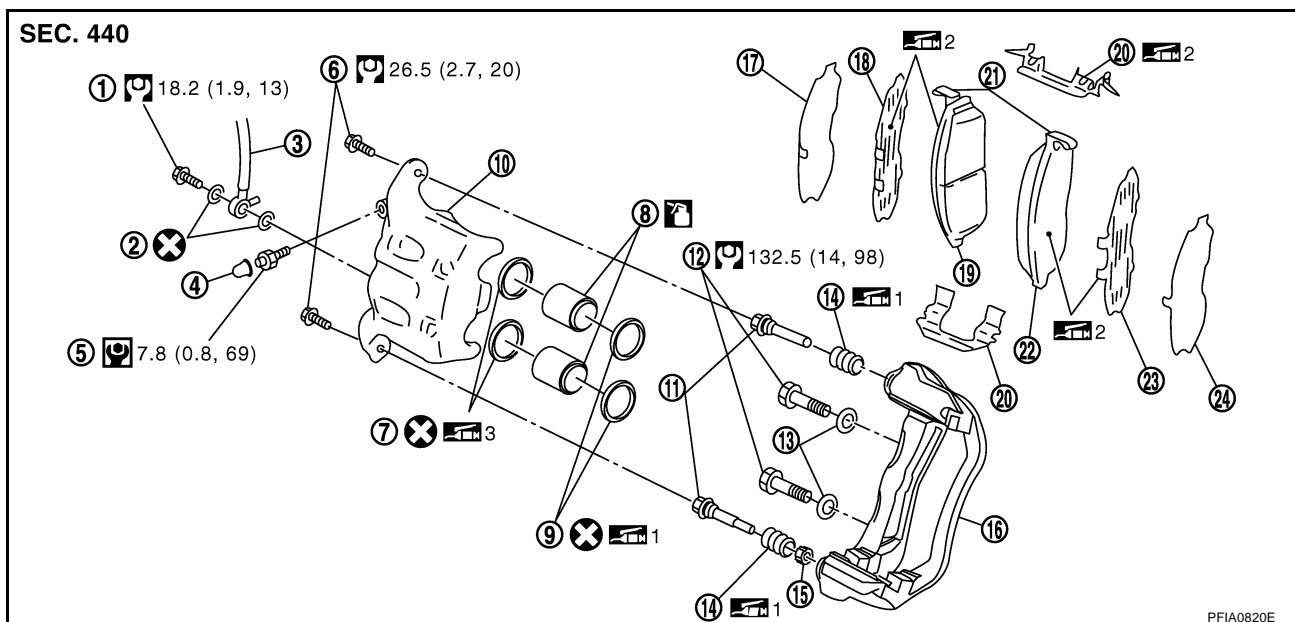

- | | | |
|-------------------|----------------------|---------------------------------|
| 1. Union bolt | 2. Copper washer | 3. Brake hose |
| 4. Cap | 5. Bleed valve | 6. Sliding pin bolt |
| 7. Piston seal | 8. Piston | 9. Piston boot |
| 10. Cylinder body | 11. Sliding pin | 12. Torque member mounting bolt |
| 13. Washer | 14. Sliding pin boot | 15. Bushing |
| 16. Torque member | 17. Inner shim cover | 18. Inner shim |
| 19. Inner pad | 20. Pad retainer | 21. Pad wear sensor |
| 22. Outer pad | 23. Outer shim | 24. Outer shim cover |

Refer to [GI-11, "Components"](#) and the followings for the symbols in the figure.

1: Apply rubber grease.

2: Apply PBC (Poly Butyl Cuprysil) grease or silicone-based grease.

3: Apply polyglycol ether based lubricant.

: Apply brake fluid.

WARNING:

Clean dust on caliper and brake pad with a vacuum dust collector to minimize the hazard of air borne particles or other materials.

CAUTION:

- While removing cylinder body, do not depress brake pedal because piston will pop out.

FRONT DISC BRAKE

- It is not necessary to remove bolts on torque member and brake hose except for disassembly or replacement of caliper assembly. In this case, hang cylinder body with a wire so as not to stretch brake hose.
- Do not damage piston boot.
- If any shim is subject to serious corrosion, replace it with a new one.
- Always replace shim and shim cover as a set when replacing brake pads.
- Keep rotor free from brake fluid.
- Burnish the brake pads and disc rotor mutually contacting surfaces, after refinishing or replacing rotors, after replacing pads, or if a soft pedal occurs at very low mileage. Refer to [BR-27, "BRAKE BURNISHING PROCEDURE"](#).

Removal and Installation of Brake Pad

REMOVAL

1. Remove tires from vehicle with power tool.
2. Remove lower sliding pin bolt.
3. Hang cylinder body with a wire, and remove pads, pad retainers, shims, and shim cover from torque member.

CAUTION:

When removing the pad retainer from the torque member, lift it in the direction indicated by the arrow in the figure so that it does not deform.

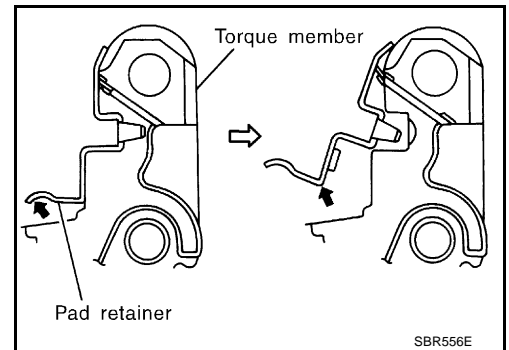

INSTALLATION

1. Apply PBC (Poly Butyl Cuprysil) grease or silicone-based grease to between pad and shim. Install shim, shim cover, to pad.
2. Apply PBC (Poly Butyl Cuprysil) grease or silicone-based grease to between pad retainer and pad. Install pad retainers and pads to torque member.

CAUTION:

- Securely assemble pad retainers so that they are not being lifted up from torque member.
- Both inner and outer pads have a pad return system on the pad retainer. Install pad return lever securely to pad wear sensor.

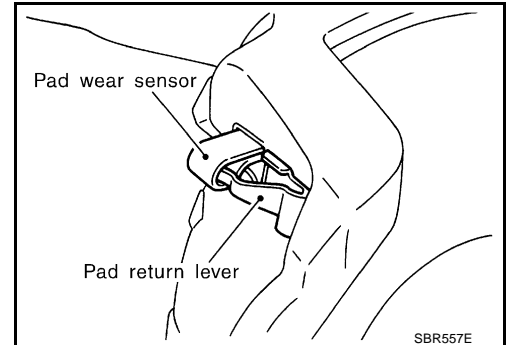

3. Install cylinder body to torque member.

CAUTION:

In the case of replacing a pad with new one, check a brake fluid level in the reservoir tank because brake fluid returns to master cylinder reservoir tank when pressing piston in.

NOTE:

Use a disc brake piston tool (commercial service tool) to easily press piston.

4. Install lower sliding pin bolt, and tighten it to the specified torque. Refer to [BR-22, "Components"](#).
5. Check front disc brake for drag.
6. Install tires to vehicle.

FRONT DISC BRAKE

NFS000SF

Removal and Installation of Brake Caliper Assembly

REMOVAL

1. Remove tires from vehicle with power tool.
2. Fasten disc rotor using wheel nut.
3. Drain brake fluid. Refer to [BR-9, "Drain and Refill"](#) .
4. Remove union bolt, and then disconnect brake hose from caliper assembly.
5. Remove torque member mounting bolts, and remove brake caliper assembly.

CAUTION:

Do not drop brake pad.

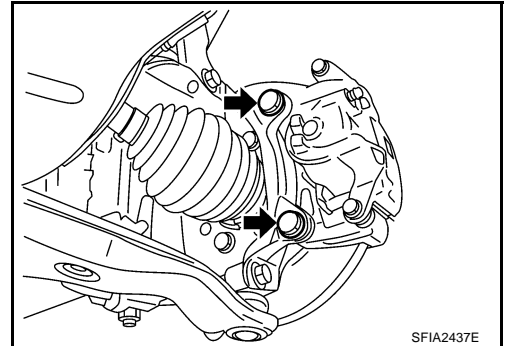

6. Remove disc rotor.

CAUTION:

Put matching marks on wheel hub assembly and disc rotor, if it is necessary to remove disc rotor.

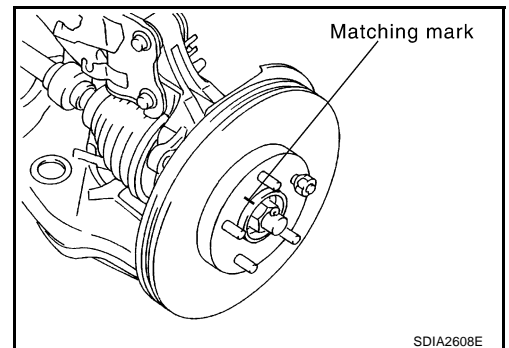

INSTALLATION

CAUTION:

- Refill with new brake fluid "DOT 3".
- Never reuse drained brake fluid.

1. Install disc rotor.

CAUTION:

Put alignment marks on disc rotor and wheel hub at the time of removal when reusing disc rotor.

2. Install brake caliper assembly to vehicle, and tighten torque member mounting bolts to the specified torque. Refer to [BR-22, "Components"](#) .

CAUTION:

Do not allow oil or any moisture on all contact surfaces between steering knuckle and caliper assembly, bolts, and washer.

3. Install brake hose to brake caliper assembly, and tighten union bolts to the specified torque. Refer to [BR-12, "Removal and Installation of Front Brake Tube and Brake Hose"](#) .
4. Refill with new brake fluid and bleed air. Refer to [BR-10, "Bleeding Brake System"](#) .
5. Check front disc brake for drag.
6. Install tires to vehicle.

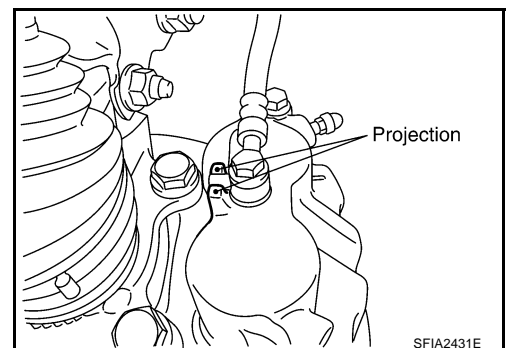

FRONT DISC BRAKE

Disassembly and Assembly of Brake Caliper Assembly

NFS000SG

NOTE:

Do not remove torque member, pads, shims, shim covers, and pad retainers when disassembling and assembling cylinder body assembly.

DISASSEMBLY

1. Remove sliding pin bolt, and then remove cylinder body from torque member.

CAUTION:

Do not drop pads, shims, shim covers and pad retainers from torque member.

2. Remove sliding pins and sliding pin boots from torque member.
3. Place a wooden block as shown in the figure, and blow air from union bolt mounting hole to remove pistons and piston boots.

CAUTION:

Do not get fingers caught in the pistons.

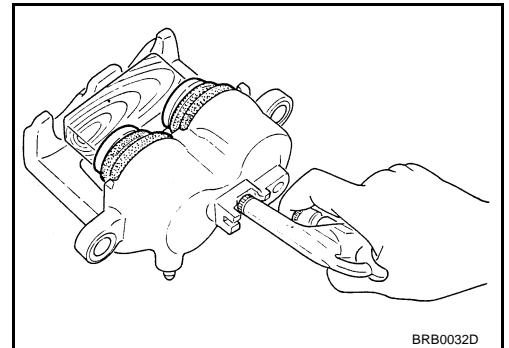

4. Remove piston seal from cylinder body using a flat-bladed screwdriver.

CAUTION:

Be careful not to damage a cylinder inner wall.

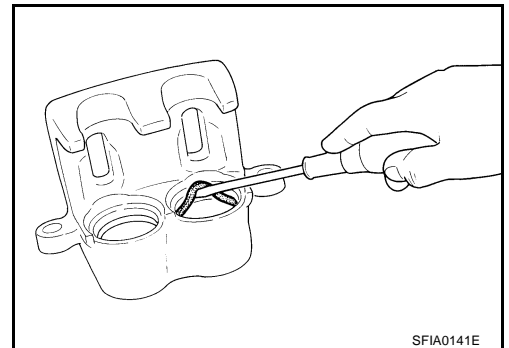

INSPECTION AFTER DISASSEMBLY

Cylinder Body

Check the inner wall of cylinder for corrosion, wear, and damage. If a malfunction is detected, replace cylinder body.

CAUTION:

Clean cylinder body using new brake fluid. Never use mineral oils such as gasoline or kerosene.

Torque Member

Check torque member for wear, cracks, and damage. Replace if there are.

Piston

Check the piston surface for corrosion, wear, and damage. If a malfunction is detected, replace applicable part.

CAUTION:

A piston sliding surface is plated. Do not polish with sandpaper.

Sliding Pin, Sliding Pin Bolt, and Sliding Pin Boot

Check sliding pin, sliding pin bolt, and sliding pin boot for wear, damage, and cracks. Replace if there are.

A
B
C
D
E
BR
G
H
I
J
K
L
M

FRONT DISC BRAKE

ASSEMBLY

1. Apply polyglycol ether based lubricant to piston seal, and install them to cylinder body.

CAUTION:

Do not reuse piston seal.

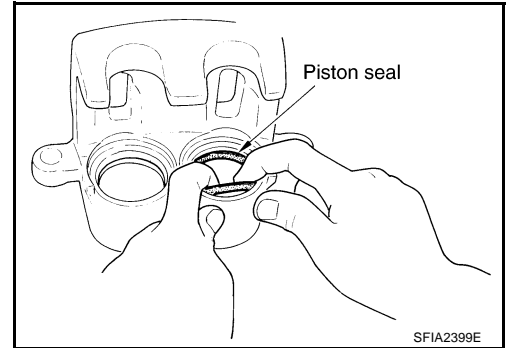

2. Apply rubber grease to piston boot. Cover the piston end with piston boot, and then install cylinder side lip on piston boot securely into a groove on cylinder body.

CAUTION:

Do not reuse piston boot.

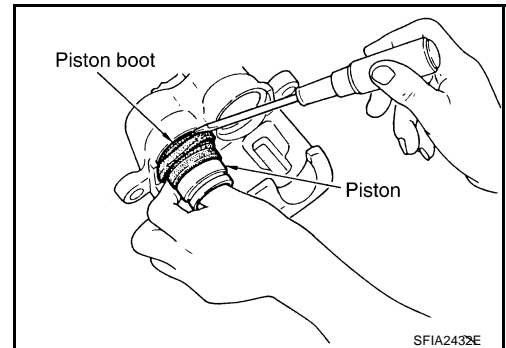

3. Apply brake fluid to piston. Push piston into cylinder body by hand and push piston boot piston-side lip into the piston groove.

CAUTION:

Press the piston evenly and vary the pressing point to prevent cylinder inner wall from being rubbed.

4. Install sliding pins and sliding pin boots to torque member.

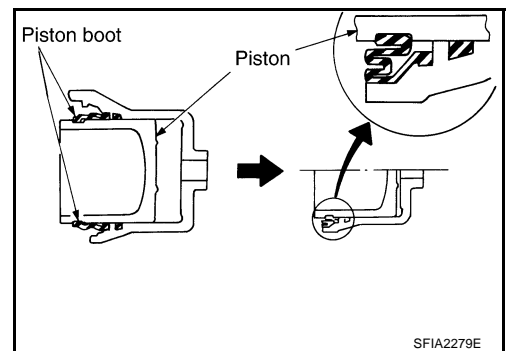

5. Install torque member to steering knuckle, and tighten mounting bolts to the specified torque. Refer to [BR-22, "Components"](#) .

CAUTION:

Do not allow oil or any moisture on all contact surfaces between steering knuckle and brake caliper assembly.

6. Press in piston until pads can be installed, and then install cylinder body to torque member.
7. Tighten sliding pin bolts to the specified torque. Refer to [BR-22, "Components"](#) .

FRONT DISC BRAKE

DISC ROTOR INSPECTION

Visual Inspection

Check surface of disc rotor for uneven wear, cracks, and serious damage. Replace if there are.

Runout Inspection

1. Fix disc rotor to wheel hub using wheel nuts (2 or more positions).
2. Inspect runout using a dial gauge. [Measured at 10 mm (0.39 in) inside the disc edge.]

Runout limit : 0.035 mm (0.0014 in)
(with it attached to the vehicle)

NOTE:

Before measuring, make sure that wheel bearing axial end play is within the specification. Refer to [FAX-5, "WHEEL BEARING INSPECTION"](#).

3. When runout exceeds limit value, displace mounting positions of disc rotor by one hole. And then find a position of the minimum value for runout.
4. Replace or lathe disc rotor if runout is outside the specified value after performing the above operation. ("MAD DL-8700", "AMMCO 700 and 705" or equivalent.)

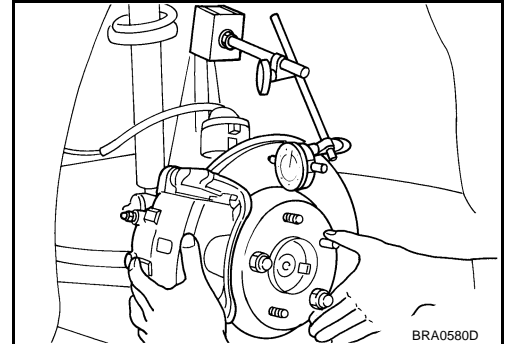

Thickness Inspection

Check thickness of the disc rotor using a micrometer. Replace disc rotor if thickness is under the wear limit.

Standard thickness : 28.0 mm (1.102 in)
Wear limit : 26.0 mm (1.024 in)
Thickness variation : 0.015 mm (0.0006 in)
(Measured at 8 positions)

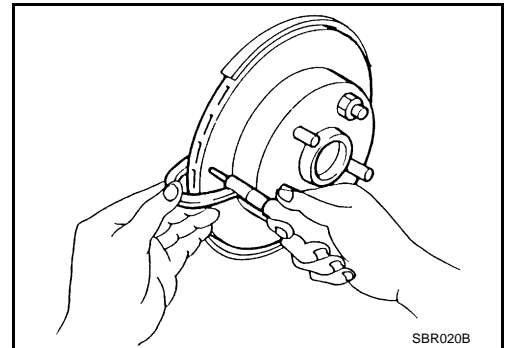

BRAKE BURNISHING PROCEDURE

Burnish contact surfaces between disc rotors and pads according to following procedure after refinishing or replacing rotors, after replacing pads, or if a soft pedal occurs at very low mileage.

CAUTION:

- **Be careful of vehicle speed because the brake does not operate easily until pad and disc rotor are securely fitted.**
 - **Only perform this procedure under safe road and traffic conditions. Use extreme caution.**
1. Drive vehicle on straight, flat road.
 2. Depress brake pedal with the power to stop vehicle within 3 to 5 seconds until the vehicle stops.
 3. Drive without depressing brake for a few minutes to cool the brake.
 4. Repeat steps 1 to 3 until pad and disc rotor are securely fitted.

REAR DISC BRAKE

REAR DISC BRAKE

PFPA:44000

On-Board Inspection PAD WEAR INSPECTION

NFS000SH

- Check pad thickness from an inspection hole on cylinder body. Check using a scale if necessary.

Standard

Standard thickness : 8.5 mm (0.335 in)

Repair limit thickness : 2.0 mm (0.079 in)

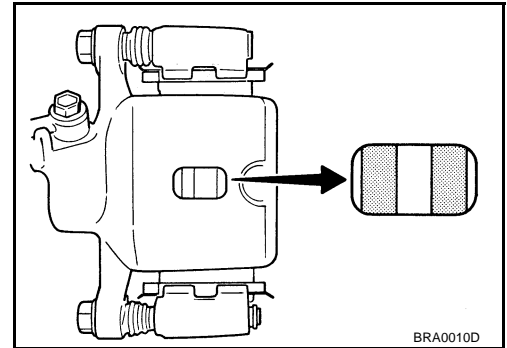

BRA0010D

Components

NFS000SI

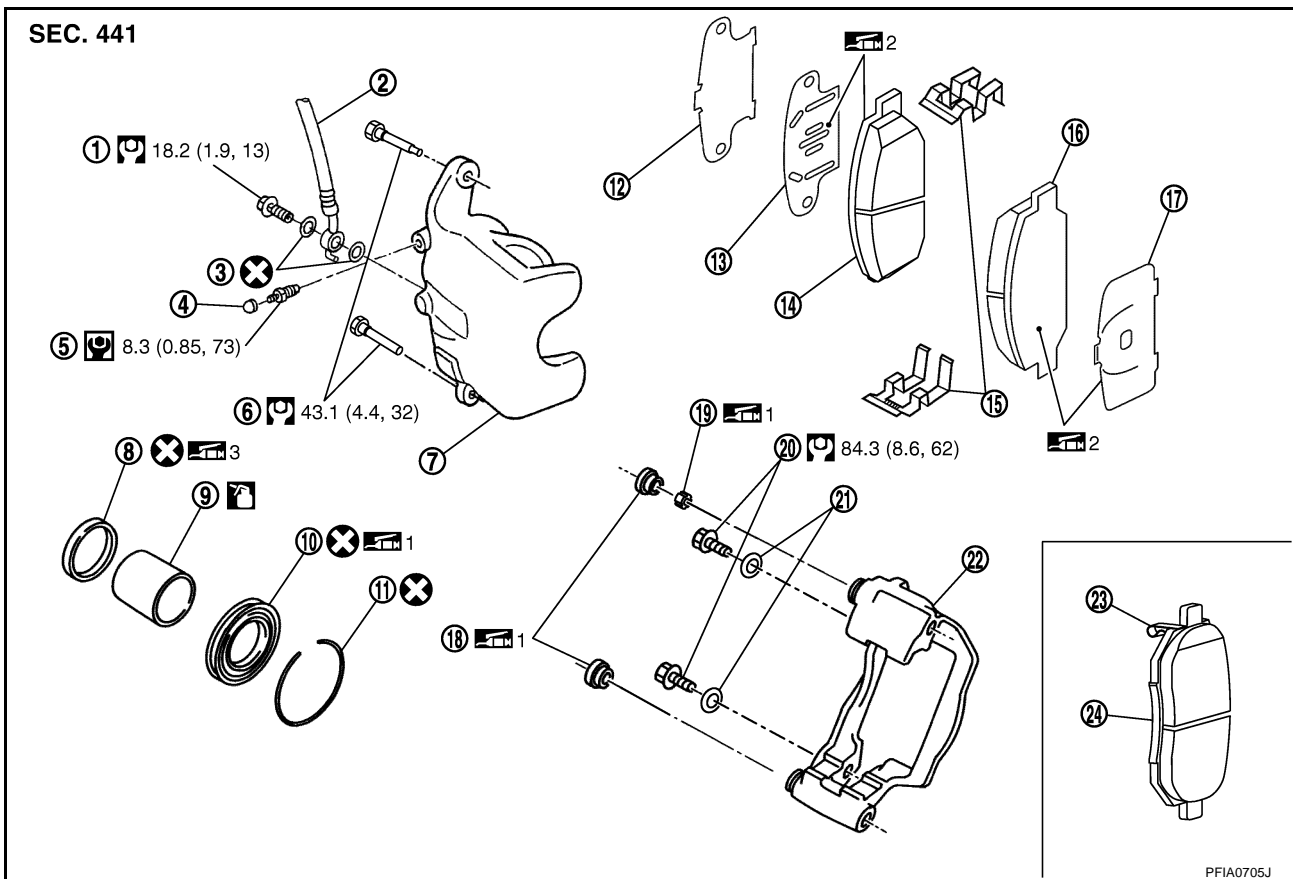

PFIA0705J

- | | | |
|-------------------|---------------------------------|----------------------|
| 1. Union bolt | 2. Brake hose | 3. Copper washer |
| 4. Cap | 5. Bleed valve | 6. Sliding pin bolt |
| 7. Cylinder body | 8. Piston seal | 9. Piston |
| 10. Piston boot | 11. Retaining ring | 12. Inner shim cover |
| 13. Inner shim | 14. Inner pad | 15. Pad retainer |
| 16. Outer pad | 17. Outer shim | 18. Sliding pin boot |
| 19. Bushing | 20. Torque member mounting bolt | 21. Washer |
| 22. Torque member | 23. Pad wear sensor | 24. Inner pad (RH) |

Refer to [GI-11, "Components"](#) and the followings for the symbols in the figure.

1: Apply rubber grease.

2: Apply PBC (Poly Butyl Cuprysil) grease or silicone-based grease.

REAR DISC BRAKE

 3: Apply polyglycol ether based lubricant.

 : Apply brake fluid.

WARNING:

Clean dust on caliper and brake pad with a vacuum dust collector to minimize the hazard of air borne particles or other materials.

CAUTION:

- While removing cylinder body, do not depress brake pedal because piston will pop out.
- It is not necessary to remove bolts on torque member and brake hose except for disassembly or replacement of caliper assembly. In this case, hang cylinder body with a wire so as not to stretch brake hose.
- Do not damage piston boot.
- If any shim is subject to serious corrosion, replace it with a new one.
- Always replace shim and shim covers as a set when replacing brake pads.
- Keep rotor free from brake fluid.
- Burnish the brake pads and disc rotor mutually contacting surfaces after refinishing or replacing rotors, after replacing pads, or if a soft pedal occurs at very low mileage. Refer to [BR-33, "BRAKE BURNISHING PROCEDURE"](#) .

Removal and Installation of Brake Pad

REMOVAL

NFS000SJ

1. Remove tires from vehicle with power tool.
2. Remove lower sliding pin bolt.
3. Hang cylinder body with a wire, and remove pads, pad retainers, shims, and shim cover from torque member.

CAUTION:

Deform pad retainer when removing pad retainer from torque member.

INSTALLATION

1. Apply PBC (Poly Butyl Cuprysil) grease or silicone-based grease to between pad and shim. Install inner shim, inner shim cover to inner pad, and outer shim, outer shim cover to outer pad.
2. Install pad retainers and pads to torque member.
3. Press in piston until pads can be installed, and then install cylinder body to torque member.

CAUTION:

In the case of replacing a pad with new one, check a brake fluid level in the reservoir tank because brake fluid returns to master cylinder reservoir tank when pressing piston in.

NOTE:

Use a disc brake piston tool (commercial service tool) to easily press piston.

4. Install upper sliding pin bolt and tighten to the specified torque. Refer to [BR-28, "Components"](#) .
5. Check rear disc brake for drag.
6. Install tires to vehicle.

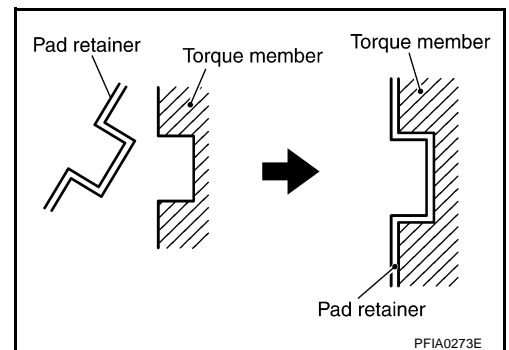

REAR DISC BRAKE

NFS000SK

Removal and Installation of Brake Caliper Assembly

REMOVAL

1. Remove tires from vehicle with power tool.
2. Fasten disc rotor using wheel nut.
3. Drain brake fluid. Refer to [BR-9, "Drain and Refill"](#) .
4. Remove union bolt and then disconnect brake hose from caliper assembly.
5. Remove torque member mounting, bolts, and remove brake caliper assembly.

CAUTION:

Do not drop brake pad.

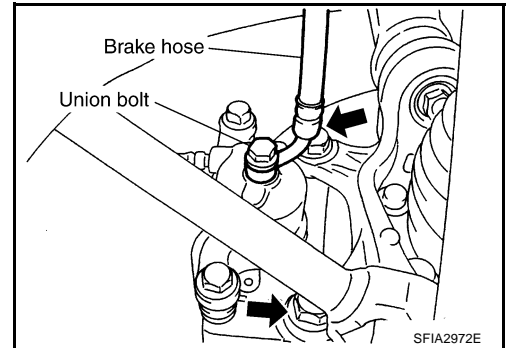

6. Remove disc rotor.

CAUTION:

Put matching marks on wheel hub assembly and disc rotor, if it necessary to remove disc rotor.

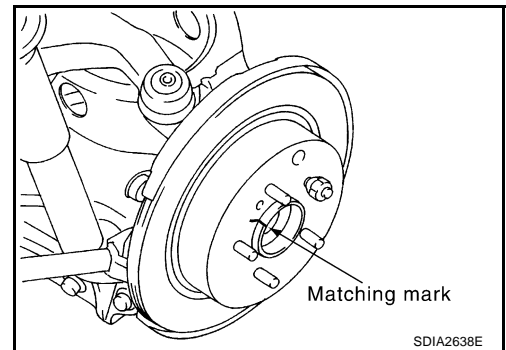

INSTALLATION

CAUTION:

- Refill with new brake fluid "DOT 3".
- Never reuse drained brake fluid.

1. Install disc rotor.

CAUTION:

Alignment marks of disc rotor and wheel hub put at the time of removal when reusing disc rotor.

2. Install brake caliper assembly vehicle, and tighten torque member mounting bolts to the specified torque. Refer to [BR-28, "Components"](#) .

CAUTION:

Before installing caliper assembly, wipe off oil and moisture on all mounting surfaces of rear axle and caliper assembly and threads, bolts and washers.

3. Install L-shaped pin of brake hose and then tighten union bolt to the specified torque. Refer to [BR-12, "Removal and Installation of Rear Brake Tube and Brake Hose"](#) .
4. Refill with new brake fluid and bleed air. Refer to [BR-10, "Bleeding Brake System"](#) .
5. Check rear disc brake for drag.
6. Install tires to vehicle.

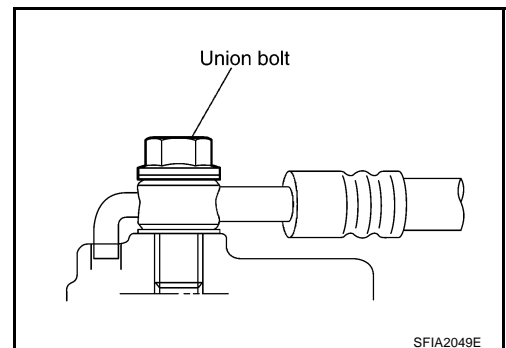

REAR DISC BRAKE

Disassembly and Assembly of Brake Caliper Assembly

NFS000SL

NOTE:

Do not remove torque member, pads, shims, shim cover, and pad retainers when disassembling and assembling cylinder body assembly.

DISASSEMBLY

1. Remove sliding pin bolt, and then remove cylinder body from torque member.

CAUTION:

Do not drop pads, shims, shim cover and pad retainers from torque member.

2. Remove sliding pin boots from torque member.
3. Remove retaining ring from cylinder body using a flat-bladed screwdriver as shown in the figure.

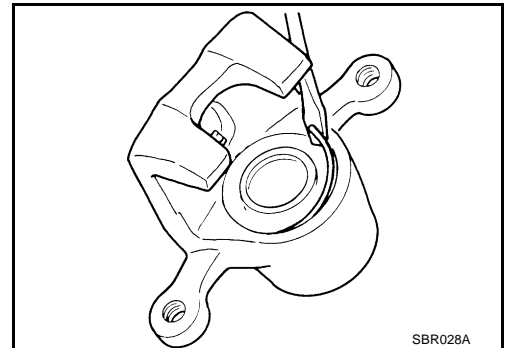

4. Place a wooden block as shown in the figure, and blow air from union bolt mounting hole to remove piston and piston boot.

CAUTION:

Do not get fingers caught in the piston.

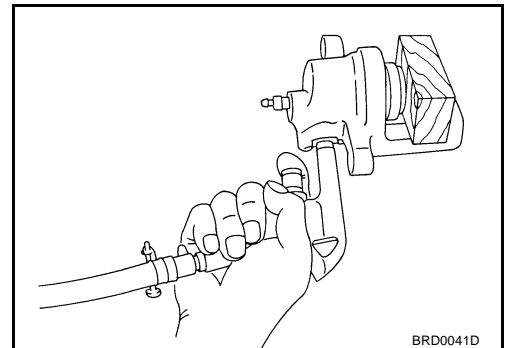

5. Remove piston seal from cylinder body using a flat-bladed screwdriver.

CAUTION:

Be careful not to damage a cylinder inner wall.

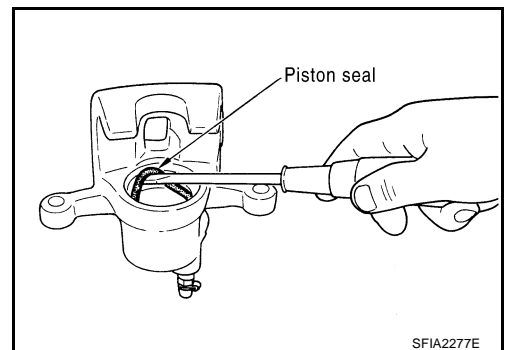

INSPECTION AFTER DISASSEMBLY

Cylinder Body

Check the inner wall of cylinder for corrosion, wear, and damage. If a malfunction is detected, replace cylinder body.

CAUTION:

Clean cylinder body using new brake fluid. Never use mineral oils such as gasoline or kerosene.

Torque Member

Check torque member for wear, cracks, and damage. Replace if there are.

Piston

Check the piston surface for corrosion, wear, and damage. If a malfunction is detected, replace applicable part.

A
B
C
D
E
BR
G
H
I
J
K
L
M

REAR DISC BRAKE

CAUTION:

A piston sliding surface is plated. Do not polish with sandpaper.

Sliding Pin Bolt, Sliding Pin Boot

Check sliding pin bolt and sliding pin boot for wear, damage, and cracks. Replace if there are.

ASSEMBLY

1. Apply polyglycol ether based lubricant to piston seal, and install them to cylinder body.

CAUTION:

Do not reuse piston seal.

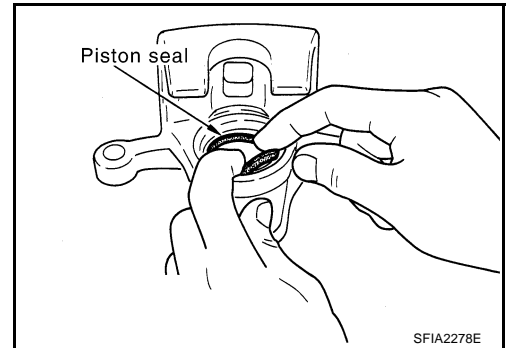

2. Apply rubber grease to piston boot. Cover the piston end with the piston boot, and then install cylinder side lip on the piston boot securely into the groove on cylinder body.

CAUTION:

Do not reuse piston boot.

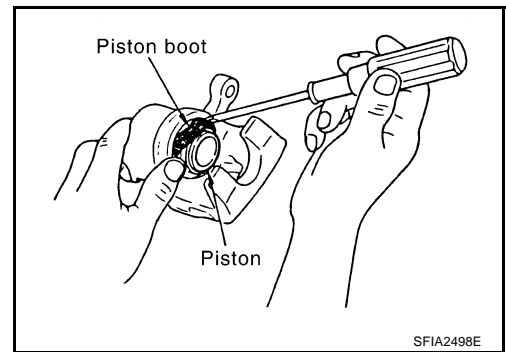

3. Apply brake fluid to piston. Push piston into cylinder body by hand and push piston boot piston side lip into the piston groove.

CAUTION:

Press the piston evenly and vary the pressing point to prevent cylinder inner wall from being rubbed.

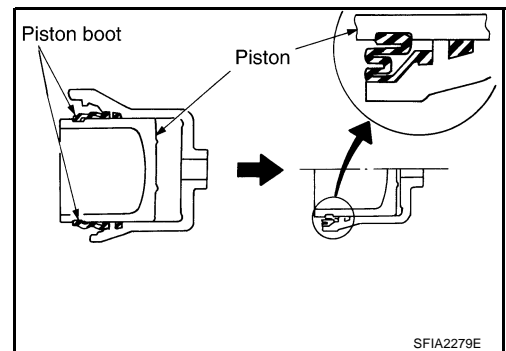

4. Secure piston boot with retaining ring.

CAUTION:

- Make sure that boot is securely engaged in the groove on cylinder body.
- Do not reuse retainer ring.

5. Install sliding pin boot to torque member.
6. Install the cylinder body to torque member, and then tighten sliding pin bolt to the specified torque. Refer to [BR-28, "Compo-nents"](#).

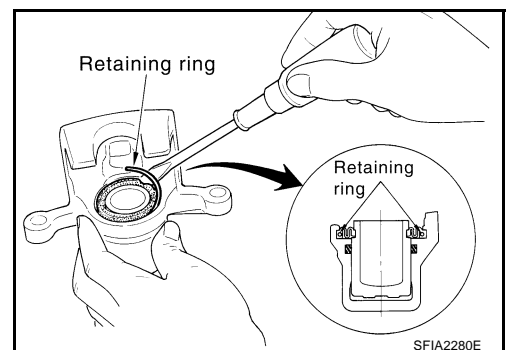

REAR DISC BRAKE

DISC ROTOR INSPECTION

Visual Inspection

Check surface of disc rotor for uneven wear, cracks, and serious damage. Replace if there are.

Runout Inspection

1. Fix disc rotor to wheel hub using wheel nuts (2 or more positions).
2. Inspect runout using dial gauge. [Measured at 10 mm (0.39 in) inside disc edge.]

Runout limit : 0.055 mm (0.0022 in)
(With it attached to the vehicle)

NOTE:

Before measuring, make sure that wheel bearing axial end play is within the specification. Refer to [RAX-5, "WHEEL BEARING INSPECTION"](#).

3. When runout exceeds limit value, displace mounting positions of disc rotor by one hole. And then find a position of the minimum value for runout.
4. Replace disc rotor if it is outside repair limit after performing the above operation.

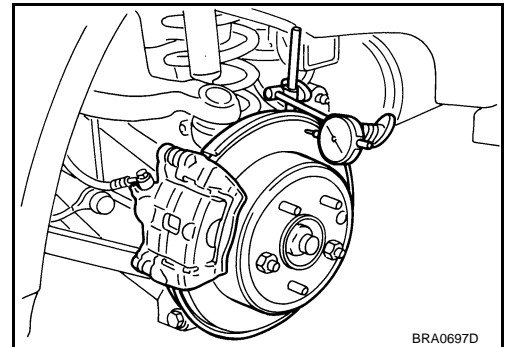

Thickness Inspection

Check the thickness of the disc rotor using a micrometer. Replace disc rotor if the thickness is under the wear limit.

Standard thickness : 16.0 mm (0.631 in)
Wear limit : 14.0 mm (0.551 in)
Thickness variation : 0.015 mm (0.0006in)
(Measured at 8 positions)

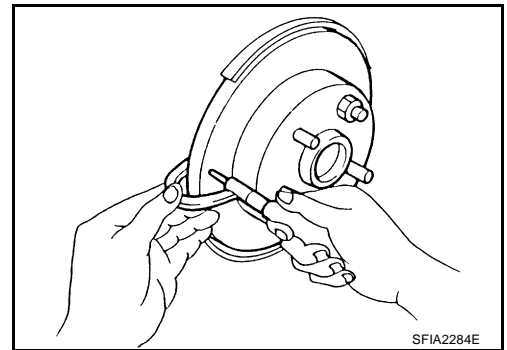

BRAKE BURNISHING PROCEDURE

Burnish contact surfaces between disc rotors and pads according to following procedure after refinishing or replacing rotors, after replacing pads, or if a soft pedal occurs at very low mileage.

CAUTION:

- **Be careful of vehicle speed because the brake does not operate easily until pad and disc rotor are securely fitted.**
 - **Only perform this procedure under safe road and traffic conditions. Use extreme caution.**
1. Drive the vehicle on a straight, flat road.
 2. Depress brake pedal with the power to stop vehicle within 3 to 5 seconds until the vehicle stops.
 3. Drive without depressing brake for a few minutes to cool the brake.
 4. Repeat steps 1 to 3 until pad and disc rotor are securely fitted.

SERVICE DATA AND SPECIFICATIONS (SDS)

SERVICE DATA AND SPECIFICATIONS (SDS)

PFP:00030

General Specifications

NFS000SM

Unit: mm (in)

Front brake	Cylinder bore diameter	45.0 (1.772) × 2
	Pad length × width × thickness	132.0 × 50.0 × 11.0 (5.20 × 1.969 × 0.433)
	Rotor outer diameter × thickness	320 × 28 (12.60 × 1.10)
Rear brake	Cylinder bore diameter	42.86 (1.687)
	Pad length × width × thickness	83.0 × 31.9 × 8.5 (3.268 × 1.256 × 0.335)
	Rotor outer diameter × thickness	308 × 16 (12.13 × 0.63)
Master cylinder	Cylinder bore diameter	25.4 (1)
Control valve	Valve model	Electric brake force distribution
Brake booster	Diaphragm diameter	255 (10)
Recommended brake fluid		DOT 3

Brake Pedal

NFS000SN

Unit: mm (in)

Brake pedal height (from dash lower panel top surface)	157 – 167 (6.18 – 6.57)
Depressed pedal height [under a force of 490 N (50 kg, 110 lb) with engine running]	90 (3.54) or more
Clearance between threaded end of the stop lamp switch/brake switch and bracket	0.74 – 1.96 (0.0291 – 0.0772)
Pedal play	3 – 11 (0.12 – 0.43)

Brake Booster

NFS000SO

Vacuum type

Unit: mm (in)

Input rod installation standard dimension	125 (4.92)
---	------------

Check Valve

NFS000SP

Vacuum leakage [at vacuum of – 66.7 kPa (– 500 mmHg, – 19.69 inHg)]	Within 1.3 kPa (10 mmHg, 0.39 inHg) of vacuum for 15 seconds
--	--

Front Disc Brake

NFS000SQ

Unit: mm (in)

Brake pad	Standard thickness	11.0 (0.433)
	Repair limit thickness	2.0 (0.079)
Disc rotor	Standard thickness	28.0 (1.102)
	Wear limit	26.0 (1.024)
	Thickness variation (measured at 8 positions)	0.015 (0.0006)
	Runout limit (with it attached to the vehicle)	0.035 (0.0014)

Rear Disc Brake

NFS000SR

Unit: mm (in)

Brake pad	Standard thickness	8.5 (0.335)
	Repair limit thickness	2.0 (0.079)
Disc rotor	Standard thickness	16.0 (0.631)
	Wear limit	14.0 (0.551)
	Thickness variation (measured at 8 positions)	0.015 (0.0006)
	Runout limit (with it attached to the vehicle)	0.055 (0.0022)