

A  
LU  
C  
D  
E  
F  
G  
H  
I  
J  
K  
L  
M

# SECTION LU

## ENGINE LUBRICATION SYSTEM

### CONTENTS

#### VQ35DE

<b>PRECAUTIONS</b> .....	<b>3</b>
Precautions for Liquid Gasket .....	3
LIQUID GASKET APPLICATION PROCEDURE...	3
<b>PREPARATION</b> .....	<b>4</b>
Special Service Tools .....	4
Commercial Service Tools .....	4
<b>LUBRICATION SYSTEM</b> .....	<b>5</b>
Lubrication Circuit .....	5
System Chart .....	6
<b>ENGINE OIL</b> .....	<b>7</b>
Inspection .....	7
ENGINE OIL LEVEL .....	7
ENGINE OIL APPEARANCE .....	7
ENGINE OIL LEAKAGE .....	7
OIL PRESSURE CHECK .....	8
Changing Engine Oil .....	9
<b>OIL FILTER</b> .....	<b>11</b>
Removal and Installation .....	11
REMOVAL .....	11
INSTALLATION .....	11
INSPECTION AFTER INSTALLATION .....	11
<b>OIL FILTER BRACKET (AWD)</b> .....	<b>13</b>
Components .....	13
Removal and Installation .....	13
REMOVAL .....	13
INSTALLATION .....	13
INSPECTION AFTER INSTALLATION .....	14
<b>OIL COOLER</b> .....	<b>15</b>
Components .....	15
Removal and Installation .....	16
REMOVAL .....	16
INSPECTION AFTER REMOVAL .....	17
INSTALLATION .....	17
INSPECTION AFTER INSTALLATION .....	17
<b>OIL PUMP</b> .....	<b>19</b>
Components .....	19
Removal and Installation .....	19
REMOVAL .....	19
INSTALLATION .....	19

INSPECTION AFTER INSTALLATION .....	19
Disassembly and Assembly .....	19
DISASSEMBLY .....	19
INSPECTION AFTER DISASSEMBLY .....	20
ASSEMBLY .....	21
<b>SERVICE DATA AND SPECIFICATIONS (SDS) .....</b>	<b>22</b>
Standard and Limit .....	22
ENGINE OIL PRESSURE .....	22
ENGINE OIL CAPACITY (APPROXIMATE) .....	22
OIL PUMP .....	22
REGULATOR VALVE .....	22

#### VK45DE

<b>PRECAUTIONS</b> .....	<b>23</b>
Precautions for Liquid Gasket .....	23
LIQUID GASKET APPLICATION PROCEDURE..	23
<b>PREPARATION</b> .....	<b>24</b>
Special Service Tools .....	24
Commercial Service Tools .....	24
<b>LUBRICATION SYSTEM</b> .....	<b>25</b>
Lubrication Circuit .....	25
System Chart .....	26
<b>ENGINE OIL</b> .....	<b>27</b>
Inspection .....	27
ENGINE OIL LEVEL .....	27
ENGINE OIL APPEARANCE .....	27
ENGINE OIL LEAKAGE .....	27
OIL PRESSURE CHECK .....	27
Changing Engine Oil .....	28
<b>OIL FILTER</b> .....	<b>30</b>
Removal and Installation .....	30
REMOVAL .....	30
INSTALLATION .....	30
INSPECTION AFTER INSTALLATION .....	30
<b>OIL PUMP</b> .....	<b>31</b>
Components .....	31
Removal and Installation .....	31
REMOVAL .....	31
INSTALLATION .....	31

---

INSPECTION AFTER INSTALLATION .....	32	<b>SERVICE DATA AND SPECIFICATIONS (SDS) .....</b>	<b>34</b>
Disassembly and Assembly .....	32	Standard and Limit .....	34
DISASSEMBLY .....	32	ENGINE OIL PRESSURE .....	34
INSPECTION AFTER DISASSEMBLY .....	32	ENGINE OIL CAPACITY (APPROXIMATE) .....	34
ASSEMBLY .....	33	OIL PUMP .....	34
		REGULATOR VALVE .....	34

## PRECAUTIONS

PFP:00001

A

### Precautions for Liquid Gasket LIQUID GASKET APPLICATION PROCEDURE

NBS004PR

LU

1. Remove old liquid gasket adhering to the liquid gasket application surface and the mating surface.
  - Remove liquid gasket completely from the liquid gasket application surface, mounting bolts, and bolt holes.
2. Wipe the liquid gasket application surface and the mating surface with white gasoline (lighting and heating use) to remove adhering moisture, grease and foreign materials.
3. Apply liquid gasket to the liquid gasket application surface.  
**Use Genuine RTV Silicone Sealant or equivalent. Refer to [GI-47, "RECOMMENDED CHEMICAL PRODUCTS AND SEALANTS"](#) .**
  - Within five minutes of liquid gasket application, install the mating component.
  - If liquid gasket protrudes, wipe it off immediately.
  - Do not retighten mounting bolts or nuts after the installation.
  - After 30 minutes or more have passed from the installation, fill engine oil and engine coolant.

C

D

E

F

G

H

I

J

K

L

M

# PREPARATION

[VQ35DE]

## PREPARATION

PFP:00002

### Special Service Tools

NBS004PS

The actual shapes of Kent-Moore tools may differ from those of special service tools illustrated here.

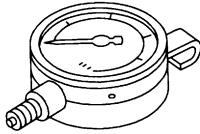
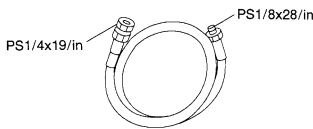
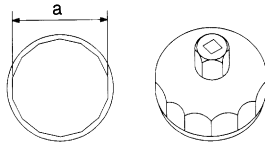
Tool number (Kent-Moore No.) Tool name		Description
ST25051001 (J25695-1) Oil pressure gauge	 NT050	Measuring oil pressure <b>Maximum measuring range: 2,452 kPa (25 kg-cm<sup>2</sup> , 356 psi)</b>
ST25052000 (J25695-2) Hose	 S-NT559	Adapting oil pressure gauge to oil pan (upper)
KV10115801 (J38956) Oil filter wrench	 S-NT375	Removing and installing oil filter <b>a: 64.3 mm (2.531 in)</b>

### Commercial Service Tools

NBS004PT

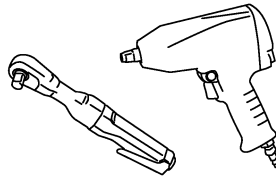
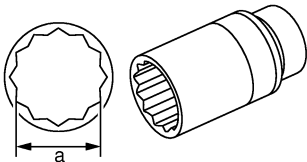
Tool name		Description
Power tools	 PBIC0190E	Loosening nuts and bolts
Deep socket	 PBIC2072E	Removing and installing oil pressure switch <b>a: 26 mm (1.02 in)</b>

### LUBRICATION SYSTEM

PF15010

### Lubrication Circuit

NBS004PU

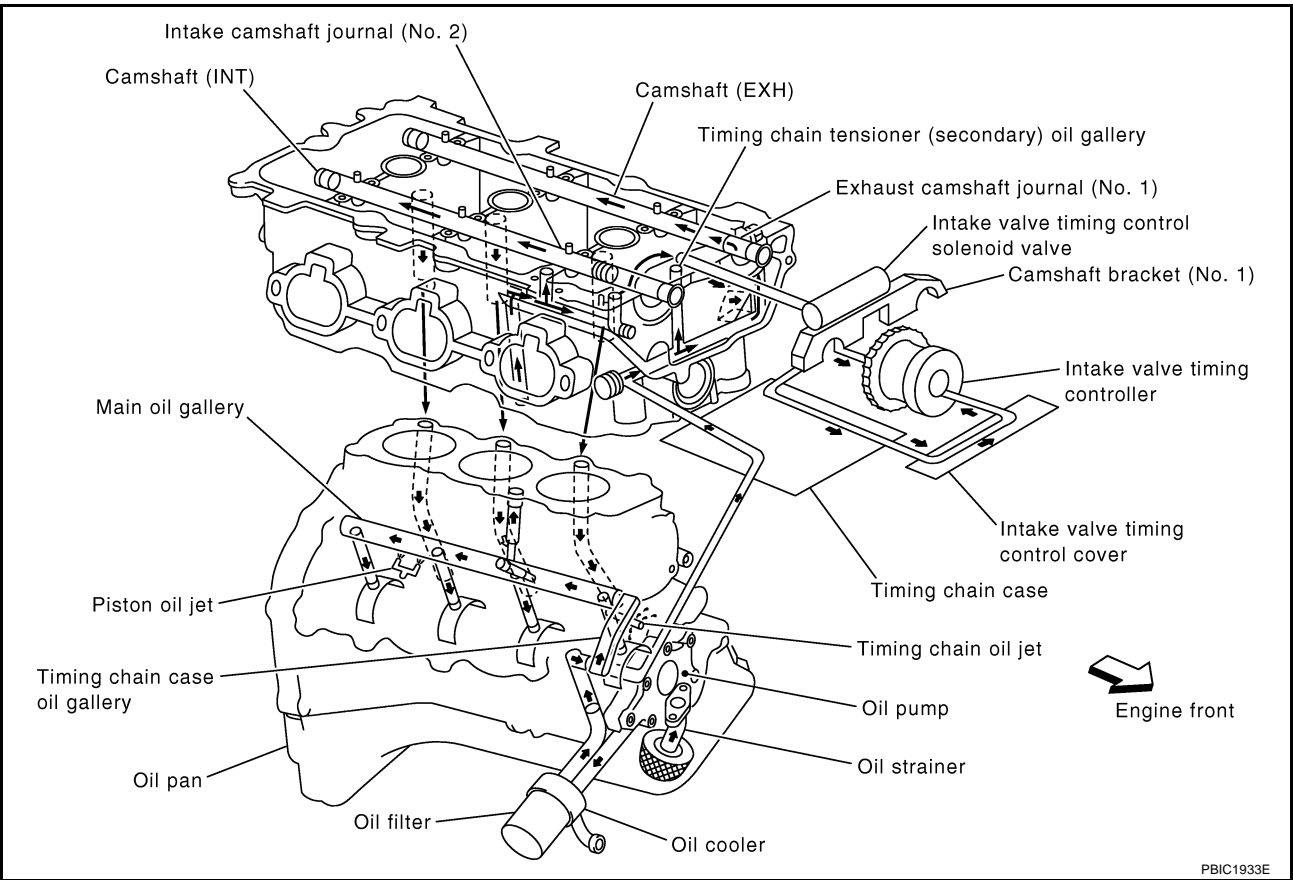

A  
LU  
C  
D  
E  
F  
G  
H  
I  
J  
K  
L  
M

# LUBRICATION SYSTEM

[VQ35DE]

## System Chart

NBS004PV

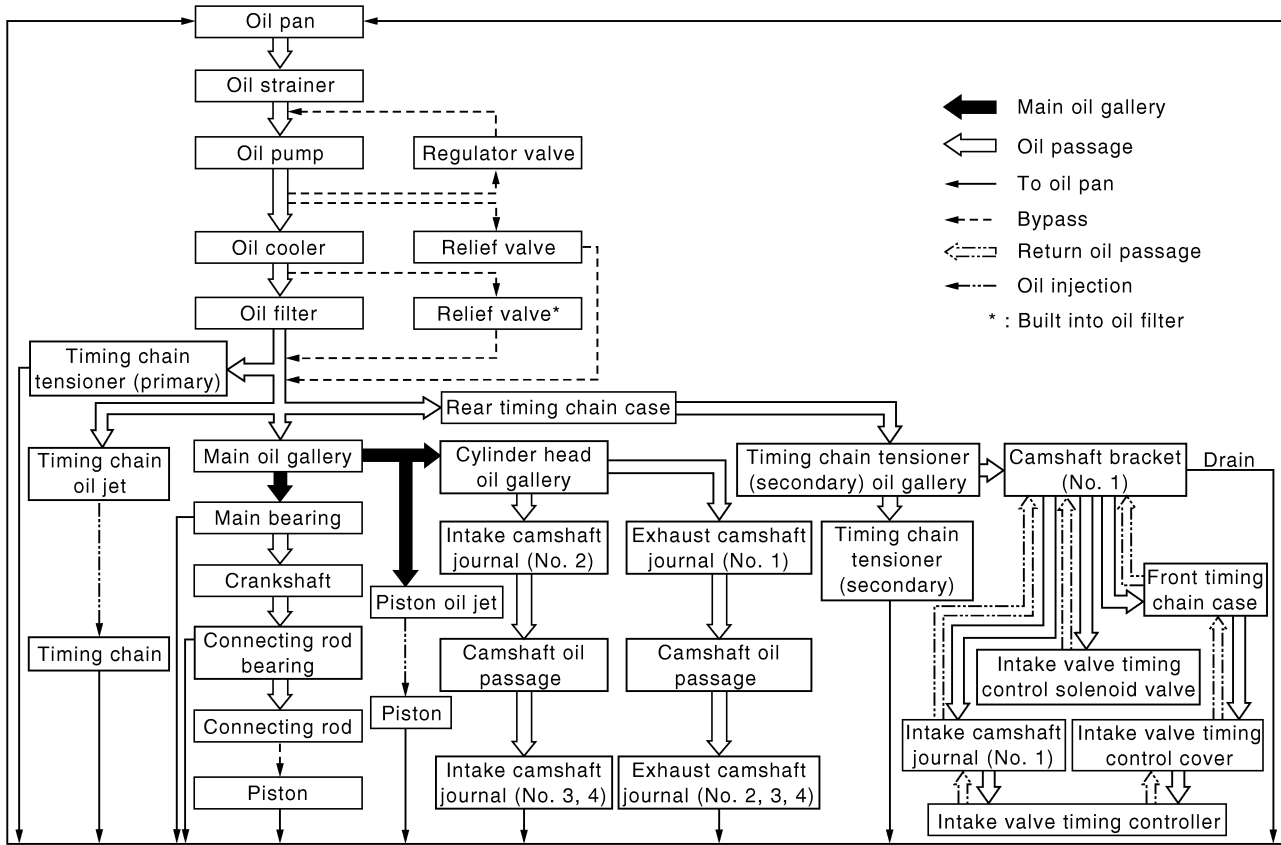

PBIC2071E

**ENGINE OIL**

PFP:KLA92

NBS004PW

**Inspection  
ENGINE OIL LEVEL****NOTE:**

Before starting engine, put vehicle horizontally and check the engine oil level. If engine is already started, stop it and allow 10 minutes before checking.

1. Pull out oil level gauge and wipe it clean.
2. Insert oil level gauge and make sure the engine oil level is within the range shown in the figure.
3. If it is out of range, adjust it.

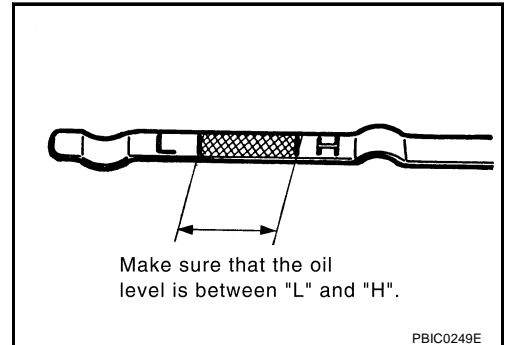
**NOTE:**

When checking the engine oil level, insert oil level gauge with its tip aligned with oil level gauge guide on cylinder head. (In figure, air cleaner case and air duct are removed.)

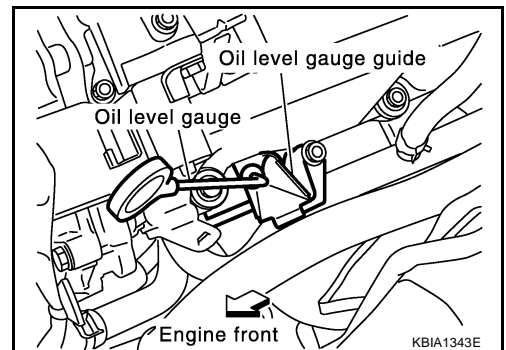
**ENGINE OIL APPEARANCE**

- Check engine oil for white turbidity or heavy contamination.
- If engine oil becomes turbid and white, it is highly probable that it is contaminated with engine coolant. Repair or replace damaged parts.

**ENGINE OIL LEAKAGE**

Check for engine oil leakage around the following areas:

- Oil pans (lower and upper)
- Oil pan drain plug
- Oil pressure switch
- Oil filter
- Oil filter bracket (AWD models)
- Oil cooler
- Water pump cover
- Chain tensioner cover
- Intake valve timing control cover and intake valve timing control solenoid valve
- Mating surface between cylinder head and rocker cover
- Mating surface between front timing chain case and rear timing chain case
- Mating surface between rear timing chain case and cylinder head
- Mating surface between rear timing chain case and cylinder block
- Mating surface between rear timing chain case and oil pan (upper)
- Mating surface between cylinder block and cylinder head

- Crankshaft oil seals (front and rear)
- Camshaft position sensor (PHASE)

## OIL PRESSURE CHECK

### WARNING:

- Be careful not to get burn yourself, as engine oil may be hot.
  - Oil pressure check should be done in "Parking position".
1. Check the engine oil level. Refer to [LU-7, "ENGINE OIL LEVEL"](#).

2. Remove front engine undercover with power tool.
3. Disconnect harness connector at oil pressure switch, and remove oil pressure switch using deep socket (commercial service tool).

### CAUTION:

Do not drop or shock oil pressure switch.

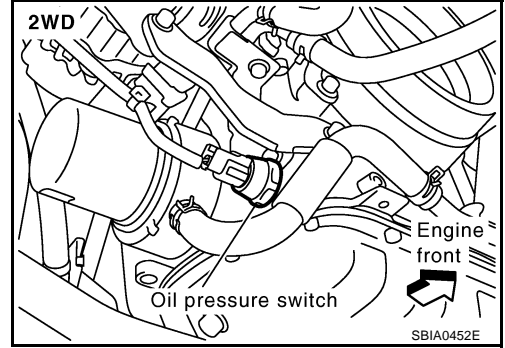

- Remove the oil pressure switch using a 26 mm (1.02 in) box wrench. (AWD models)

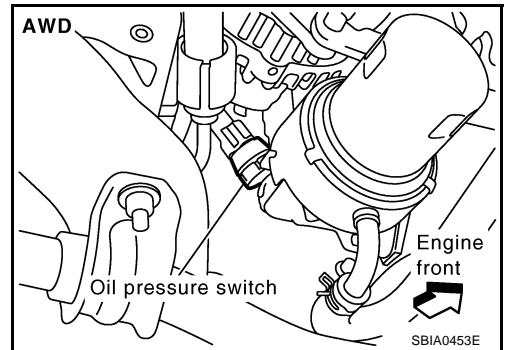

4. Install the oil pressure gauge (SST) and hose (SST).

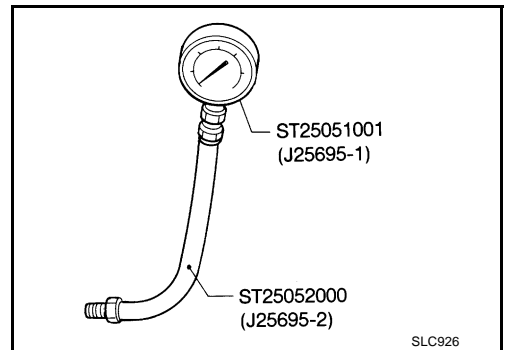

5. Start the engine and warm it up to normal operating temperature.
6. Check the engine oil pressure with engine running under no-load.

### NOTE:

When the engine oil temperature is low, the engine oil pressure becomes high.

### Engine oil pressure [Engine oil temperature at 80 °C (176 °F)]

Unit: [kPa (kg/cm<sup>2</sup> , psi)]

Engine speed	Approximate discharge pressure
Idle speed	More than 98 (1.0, 14)
2,000 rpm	More than 294 (3.0, 43)

If difference is extreme, check engine oil passage and oil pump for engine oil leaks.



7. After the inspections, install oil pressure switch as follows:
  - a. Remove old liquid gasket adhering to oil pressure switch and the mating surface.
  - b. Apply liquid gasket and tighten oil pressure switch to the specification.  
**Use Genuine RTV Silicone Sealant or equivalent. Refer to [GI-47, "RECOMMENDED CHEMICAL PRODUCTS AND SEALANTS"](#) .**

**Oil pressure switch:**

: **14.8 N·m (1.5 kg·m, 11 ft·lb)**

- c. After warming up engine, make sure there is no leakage of engine oil with running engine.

## Changing Engine Oil

NBS004PX

**WARNING:**

- Be careful not to get burn yourself, as engine oil may be hot.
  - Prolonged and repeated contact with used engine oil may cause skin cancer. Try to avoid direct skin contact with used engine oil. If skin contact is made, wash thoroughly with soap or hand cleaner as soon as possible.
1. Warm up the engine, and check for engine oil leakage from engine components. Refer to [LU-7, "ENGINE OIL LEAKAGE"](#) .
  2. Stop the engine and wait for 10 minutes.
  3. Loosen oil filler cap.
  4. Remove mounting bolts, and then pull down the rear of front engine undercover (1) and secure it using clip.
  5. Remove drain plug (2) and then drain engine oil.

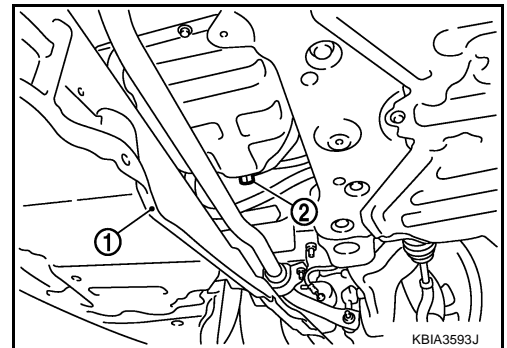

6. Install drain plug with new washer. Refer to [EM-31, "OIL PAN AND OIL STRAINER"](#) .

**CAUTION:**

**Be sure to clean drain plug and install with new washer.**

**Oil pan drain plug:**

: **34.3 N·m (3.5 kg·m, 25 ft·lb)**

7. Refill with new engine oil.  
**Engine oil specification and viscosity:**  
 Refer to [MA-12, "RECOMMENDED FLUIDS AND LUBRICANTS"](#) .

**Engine oil capacity (Approximate):**

Unit: ℓ (US qt, Imp qt)

Drain and refill	With oil filter change	4.7 (5, 4-1/8)
	Without oil filter change	4.4 (4-5/8, 3-7/8)
Dry engine (Overhaul)		5.4 (5-3/4, 4-3/4)

**CAUTION:**

- When filling engine oil, do not pull out oil level gauge.
  - The refill capacity depends on the engine oil temperature and drain time. Use these specifications for reference only.
  - Always use oil level gauge to determine the proper amount of engine oil in engine.
8. Warm up the engine and check area around drain plug and oil filter for engine oil leakage.
  9. Stop the engine and wait for 10 minutes.

10. Check the engine oil level. Refer to [LU-7, "ENGINE OIL LEVEL"](#) .

## OIL FILTER

### Removal and Installation

#### REMOVAL

1. Remove front engine undercover with power tool.
2. Using oil filter wrench (SST), remove oil filter.

**CAUTION:**

- Oil filter is provided with relief valve. Use Genuine Nissan Oil Filter or equivalent.
- Be careful not to get burned when engine and engine oil may be hot.
- When removing, prepare a shop cloth to absorb any engine oil leakage or spillage.
- Do not allow engine oil to adhere to drive belts.
- Completely wipe off any engine oil that adheres to engine and vehicle.

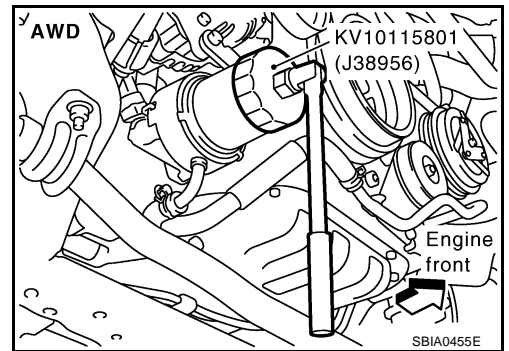
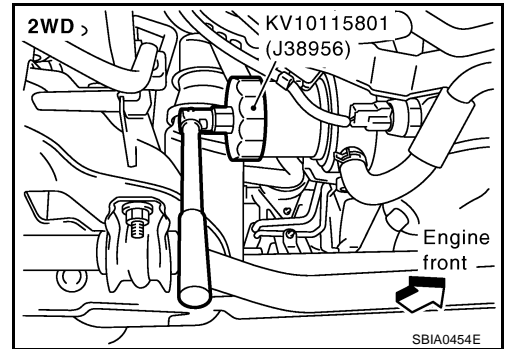

#### INSTALLATION

1. Remove foreign materials adhering to oil filter installation surface.
2. Apply engine oil to the oil seal contact surface of new oil filter.

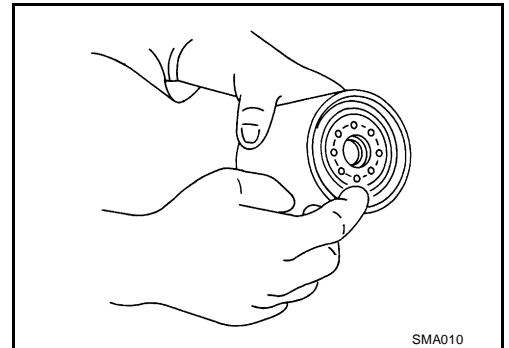

3. Screw oil filter manually until it touches the installation surface, then tighten it by 2/3 turn. Or tighten to the specification.

**Oil filter:**

: 17.7 N·m (1.8 kg·m, 13 ft·lb)

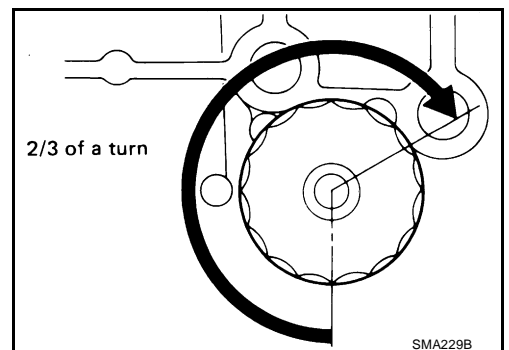

#### INSPECTION AFTER INSTALLATION

1. Check the engine oil level. Refer to [LU-7, "ENGINE OIL"](#).
2. Start the engine, and check there is no leak of engine oil.

A  
LU  
C  
D  
E  
F  
G  
H  
I  
J  
K  
L  
M

3. Stop the engine and wait for 10 minutes.
4. Check the engine oil level, and adjust the level. Refer to [LU-7, "ENGINE OIL"](#) .

## OIL FILTER BRACKET (AWD)

PFP:15238

### Components

NBS004PZ

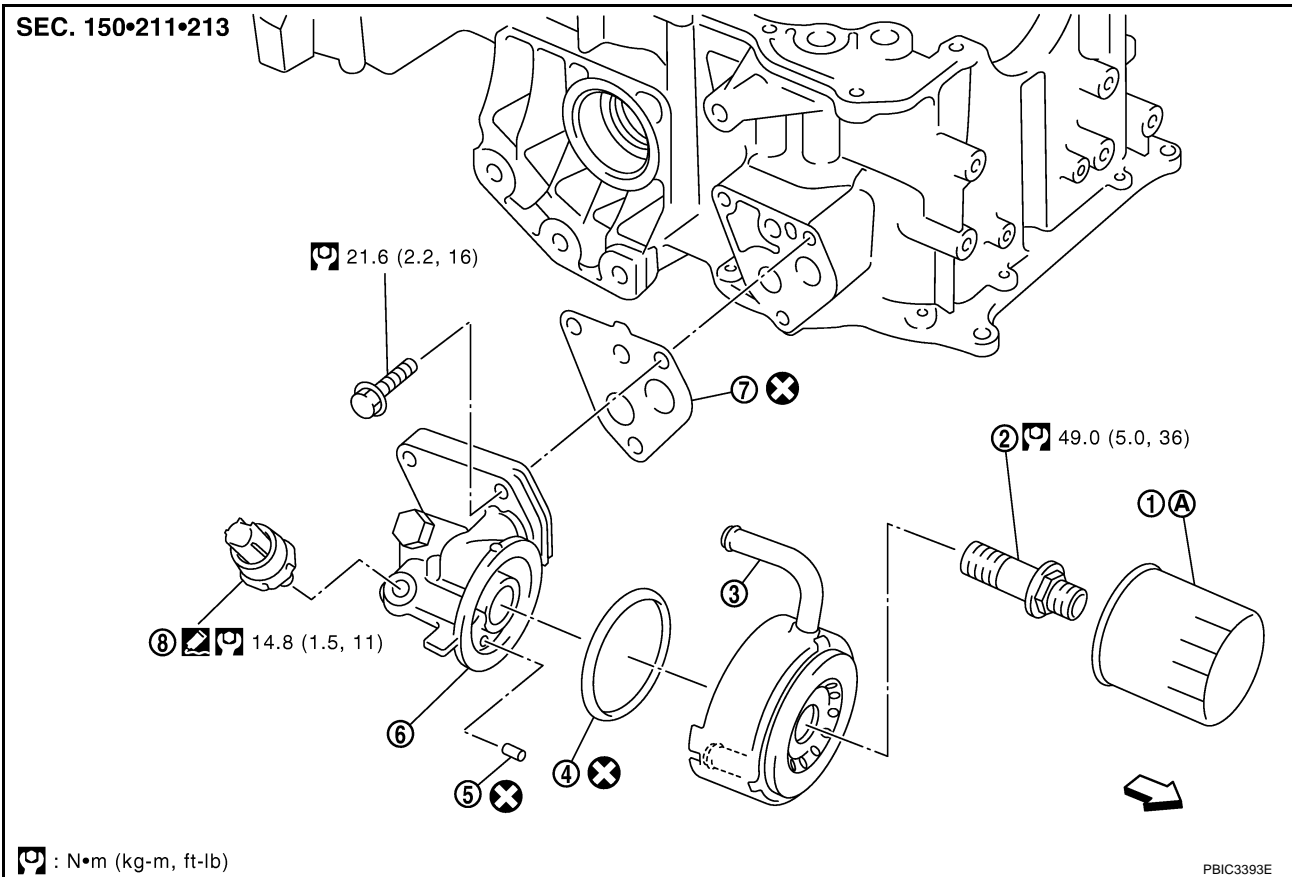

- |               |                        |                       |
|---------------|------------------------|-----------------------|
| 1. Oil filter | 2. Connector bolt      | 3. Oil cooler         |
| 4. O-ring     | 5. Relief valve        | 6. Oil filter bracket |
| 7. Gasket     | 8. Oil pressure switch |                       |

A. Refer to [LU-11](#)

← : Engine front

- Refer to [GI-11, "Components"](#) for symbols in the figure.

## Removal and Installation

### REMOVAL

NBS004Q0

#### WARNING:

**Be careful not to get burn yourself, as engine oil may be hot.**

- Remove front engine undercover with power tool.
- Using the oil filter wrench [SST: KV10115801 (J38956)], remove oil filter. Refer to [LU-11, "OIL FILTER"](#).

#### CAUTION:

**Do not spill engine oil on drive belt.**

- Remove connector bolt, and then oil cooler with water hoses connected.
- Disconnect oil pressure switch harness connectors.
- Remove oil filter bracket from oil pan (upper).
- Remove oil pressure switch from oil filter bracket.

### INSTALLATION

Note the following, and install in the reverse order of removal.

- Install oil pressure switch as follows:
  - Remove old liquid gasket adhering to oil filter bracket.
  - Apply liquid gasket and install oil pressure switch.

## OIL FILTER BRACKET (AWD)

[VQ35DE]

---

Use Genuine RTV Silicone Sealant or equivalent. Refer to [GI-47, "RECOMMENDED CHEMICAL PRODUCTS AND SEALANTS"](#) .

- Align cutout on oil cooler with protrusion on oil filter bracket. Refer to [LU-17, "INSTALLATION"](#) .

### INSPECTION AFTER INSTALLATION

1. Check the engine oil level and add engine oil. Refer to [LU-7, "ENGINE OIL"](#) .
2. Start the engine, and check there is no leak of engine oil.
3. Stop the engine and wait for 10 minutes.
4. Check the engine oil level again. Refer to [LU-7, "ENGINE OIL"](#) .

## OIL COOLER Components

### 2WD models

SEC. 150•211•213

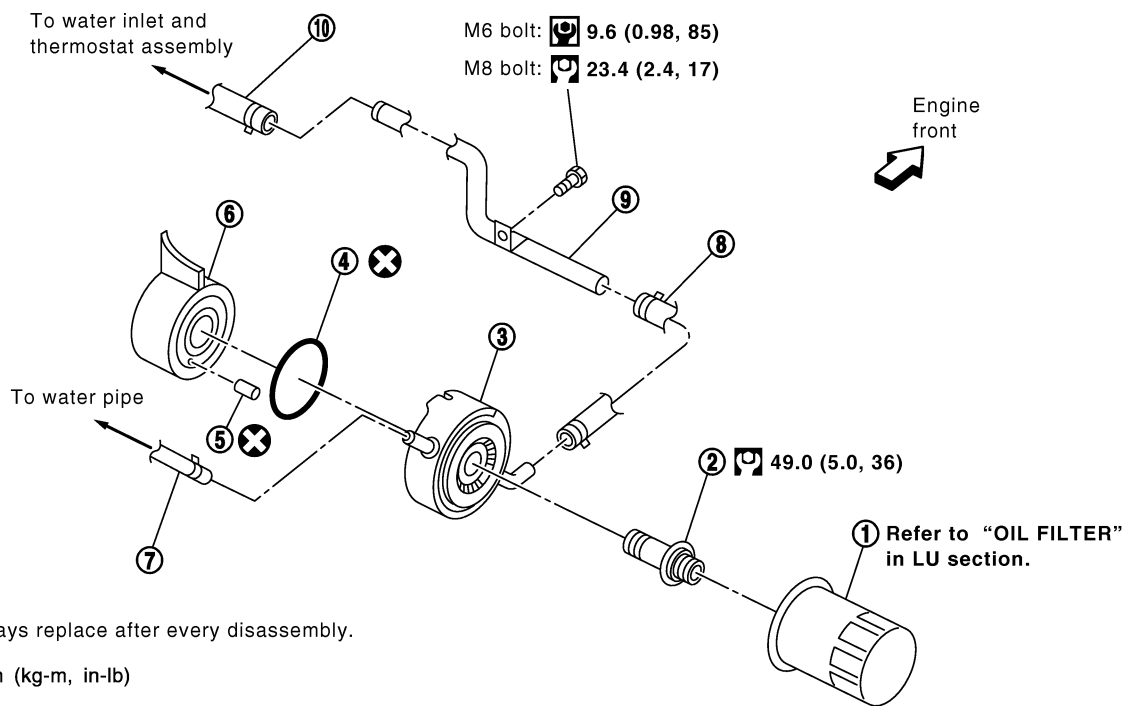

PBIC2403E

- |                |                   |                               |
|----------------|-------------------|-------------------------------|
| 1. Oil filter  | 2. Connector bolt | 3. Oil cooler                 |
| 4. O-ring      | 5. Relief valve   | 6. Oil pan (upper) right side |
| 7. Water hose  | 8. Water hose     | 9. Water pipe                 |
| 10. Water hose |                   |                               |

# OIL COOLER

[VQ35DE]

## AWD models

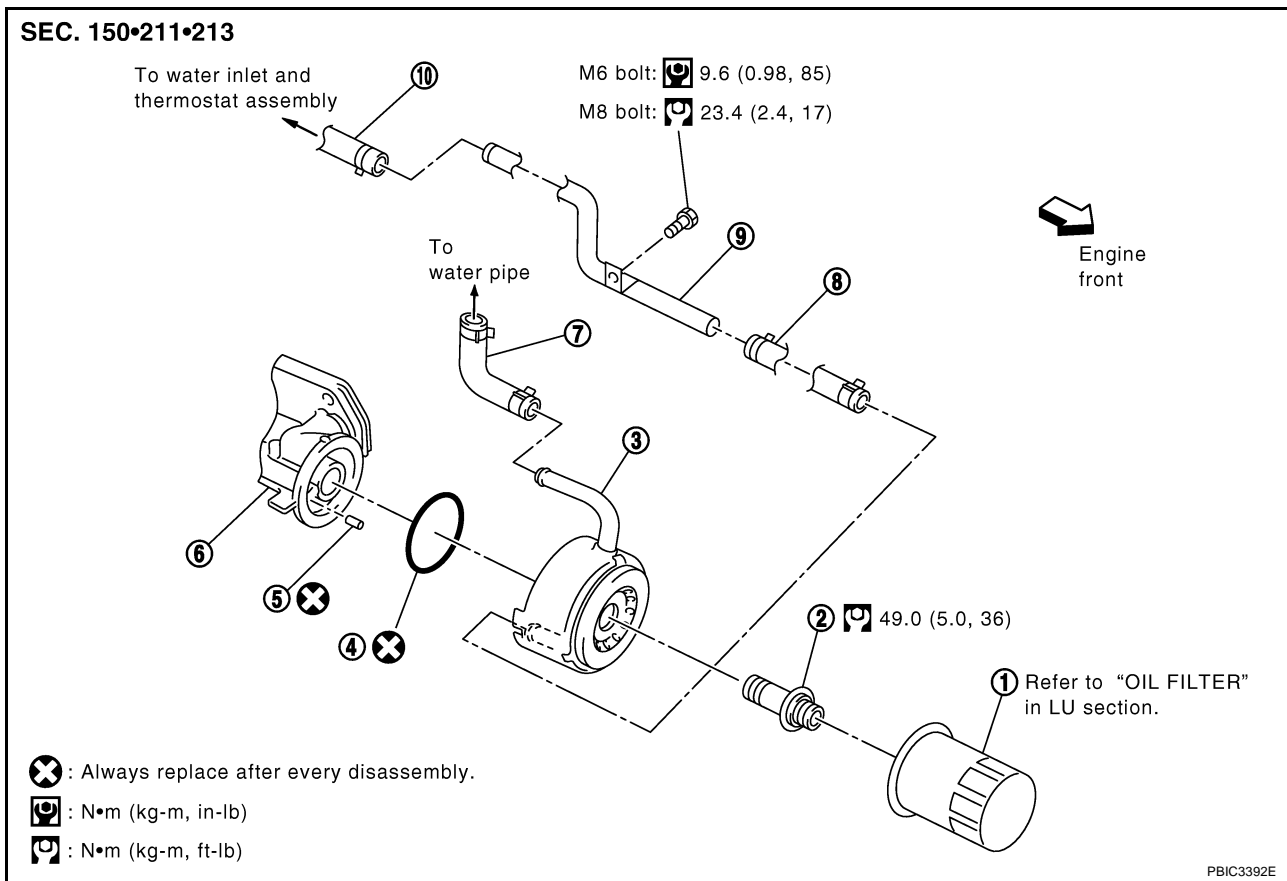

- |                |                   |                       |
|----------------|-------------------|-----------------------|
| 1. Oil filter  | 2. Connector bolt | 3. Oil cooler         |
| 4. O-ring      | 5. Relief valve   | 6. Oil filter bracket |
| 7. Water hose  | 8. Water hose     | 9. Water pipe         |
| 10. Water hose |                   |                       |

## Removal and Installation

### REMOVAL

NBS004Q2

#### WARNING:

Be careful not to get burn yourself, as engine oil and engine coolant may be hot.

#### NOTE:

When removing oil cooler only, step 2 is unnecessary.

1. Remove front engine undercover with power tool.
2. Drain engine coolant from radiator and cylinder block. Refer to [CO-11, "Changing Engine Coolant"](#) and [EM-125, "DISASSEMBLY"](#).

#### NOTE:

Perform this step when removing water pipes.

3. Disconnect water hoses from oil cooler.
  - When removing oil cooler only, pinching water hoses near oil cooler to prevent engine coolant from spilling out.
  - Remaining engine coolant in piping will come out. Use a tray to collect it.

#### CAUTION:

- Perform this step when the engine is cold.
- Do not spill engine coolant on drive belts.

4. Using oil filter wrench [SST: KV10115801 (J38956)], remove oil filter. Refer to [LU-11, "OIL FILTER"](#).

#### CAUTION:

Do not spill engine oil on drive belts.

5. Remove connector bolt, and remove oil cooler.



**CAUTION:**

Do not spill engine oil to rubber parts such as drive belts and engine mounting insulator.

6. Remove water pipes, as necessary.

**INSPECTION AFTER REMOVAL****Oil Cooler**

Check oil cooler for cracks. Check oil cooler for clogging by blowing through engine coolant inlet. If necessary, replace oil cooler.

**Relief Valve**

Check relief valve with the following procedure.

- Press steel ball of relief valve using a clean plastic stick. Make sure that valve moves smoothly and proper spring repulsion is felt.
- Replace relief valve, if necessary, with the following procedure.
  - Remove the relief valve by prying using a screwdriver.

**CAUTION:**

Be careful not to damage the mounting hole.

- Press in the relief valve until it reaches a depth of 7 mm (0.28 in) from end surface of oil pan (upper) using approximately 10 mm (0.39 in) diameter drift.

**CAUTION:**

Carefully press in the relief valve by aligning its mounting hole side with the axle center so as not to cause deformation.

**INSTALLATION**

Note the following, and install in the reverse order of removal.

- Make sure that no foreign objects are adhering to the installation planes of oil cooler, oil pan (upper) (2WD models) or oil cooler bracket (AWD models).

**2WD Models**

Align cutout on oil cooler with protrusion on oil pan (upper) side, and tighten connector bolt.

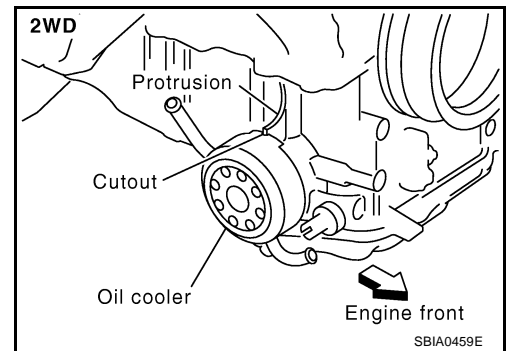
**AWD Models**

Align cutout on oil cooler with protrusion on oil cooler bracket side, and tighten connector bolt.

- 1 : Connector bolt
- A : Cut out
- B : AWD

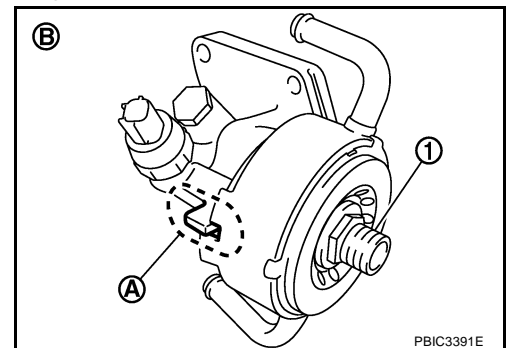
**INSPECTION AFTER INSTALLATION**

1. Check the engine oil level and the engine coolant level and add engine oil and engine coolant. Refer to [LU-7, "ENGINE OIL"](#) and [CO-11, "ENGINE COOLANT"](#).
2. Start the engine, and check there is no leaks of engine oil or engine coolant.

## OIL COOLER

[VQ35DE]

---

3. Stop the engine and wait for 10 minutes.
4. Check the engine oil level and the engine coolant level again. Refer to [LU-7, "ENGINE OIL"](#) and [CO-11, "ENGINE COOLANT"](#) .

## OIL PUMP

PFP:15010

## Components

NBS004Q3

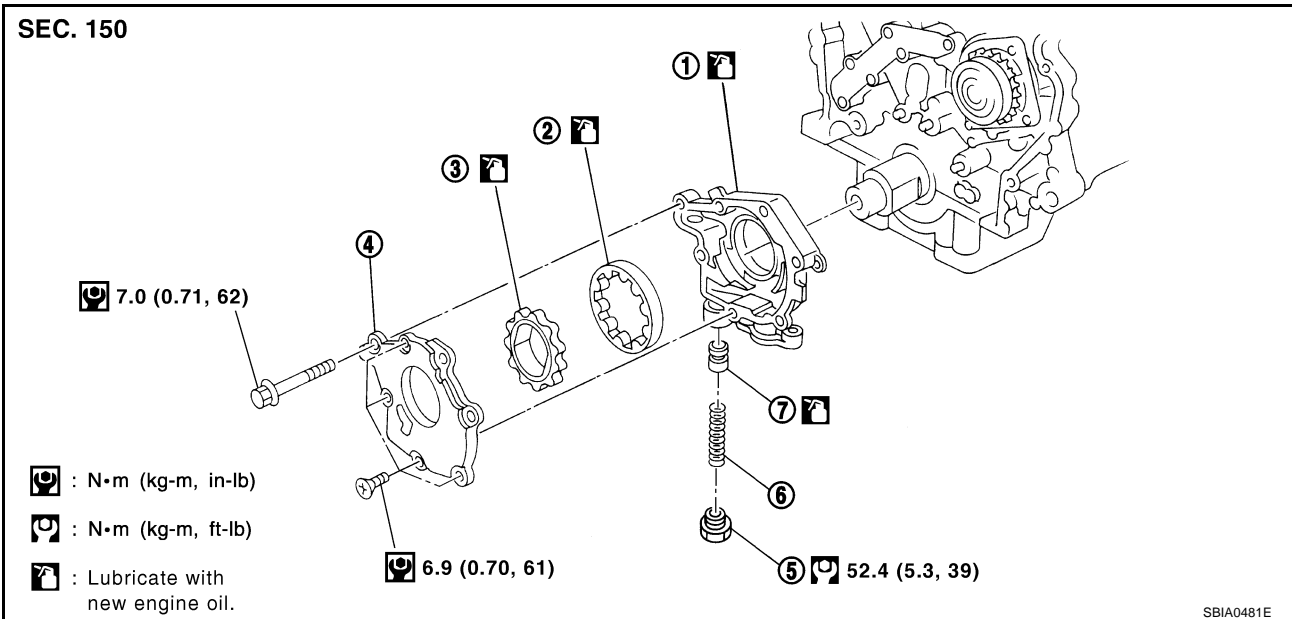

- |                    |                         |                           |
|--------------------|-------------------------|---------------------------|
| 1. Oil pump body   | 2. Oil pump outer rotor | 3. Oil pump inner rotor   |
| 4. Oil pump cover  | 5. Regulator valve plug | 6. Regulator valve spring |
| 7. Regulator valve |                         |                           |

## Removal and Installation

## REMOVAL

NBS004Q4

1. Remove oil pans (lower and upper) and oil strainer. Refer to [EM-31, "OIL PAN AND OIL STRAINER"](#).
2. Remove front timing chain case and timing chain (primary). Refer to [EM-66, "TIMING CHAIN"](#).
3. Remove oil pump assembly.

## INSTALLATION

**CAUTION:**

Before installation, apply new engine oil to the parts as instructed in the figure.

Note the following, and install in the reverse order of removal.

- When installing, align crankshaft flat faces with oil pump inner rotor flat faces.

## INSPECTION AFTER INSTALLATION

1. Check the engine oil level. Refer to [LU-7, "ENGINE OIL"](#).
2. Start the engine, and check there is no leaks of engine oil.
3. Stop the engine and wait for 10 minutes.
4. Check the engine oil level and adjust the level. Refer to [LU-7, "ENGINE OIL"](#).

## Disassembly and Assembly

## DISASSEMBLY

NBS004Q5

1. Remove oil pump cover.
2. Remove oil pump inner rotor and oil pump outer rotor from oil pump body.
3. After removing regulator valve plug, remove regulator valve spring and regulator valve.

## INSPECTION AFTER DISASSEMBLY

### Oil Pump Clearance

- Measure the clearance with feeler gauge.
  - Clearance between oil pump outer rotor and oil pump body (Position "1")
 

**Standard : 0.114 - 0.260 mm (0.0045 - 0.0102 in)**
  - Tip clearance between oil pump inner rotor and oil pump outer rotor (Position "2")
 

**Standard : Below 0.180 mm (0.0071 in)**
  - If out of the standard, replace inner rotor and outer rotor.

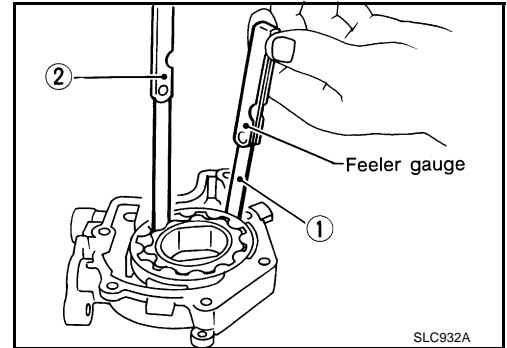

- Measure the clearance with feeler gauge and straightedge.
  - Side clearance between oil pump inner rotor and oil pump body (Position "3")
 

**Standard : 0.030 - 0.070 mm (0.0012 - 0.0028 in)**
  - Side clearance between oil pump outer rotor and oil pump body (Position "4")
 

**Standard : 0.050 - 0.110 mm (0.0020 - 0.0043 in)**

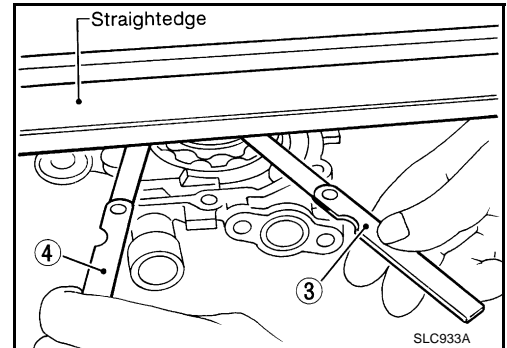

- Calculate the clearance between oil pump inner rotor and oil pump body as follows:

### OIL PUMP BODY INNER DIAMETER

- Measure the inner diameter of oil pump body with inside micrometer. (Position "5")

### OIL PUMP INNER ROTOR OUTER DIAMETER

- Measure the outer diameter of protruded portion of oil pump inner rotor with micrometer. (Position "6")

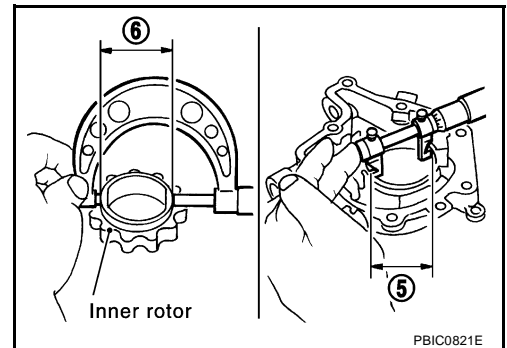

### OIL PUMP INNER ROTOR TO OIL PUMP BODY CLEARANCE

- (Clearance) = (Oil pump body inner diameter) – (Oil pump inner rotor outer diameter)
 

**Standard : 0.045 - 0.091 mm (0.0018 - 0.0036 in)**
- If measured/calculated values are out of the standard, replace oil pump assembly.

## Regulator Valve Clearance

(Clearance) = (Regulator valve hole diameter) – (Regulator valve outer diameter)

**Standard : 0.040 - 0.097 mm (0.0016 - 0.0038 in)**

- If the calculated value is out of the standard, replace oil pump assembly.

### CAUTION:

- Coat regulator valve with engine oil.
- Make sure that it falls smoothly into valve hole by its own weight.

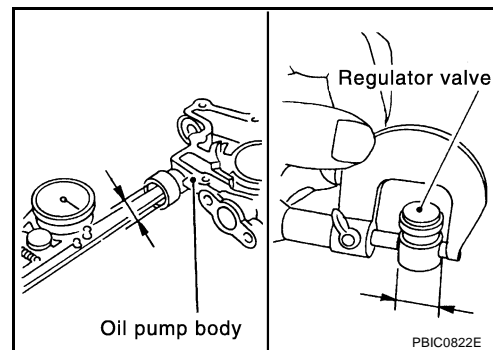

## ASSEMBLY

Note the following, and assemble in the reverse order of disassembly.

- Install oil pump inner rotor with the groove faced to oil pump cover side.

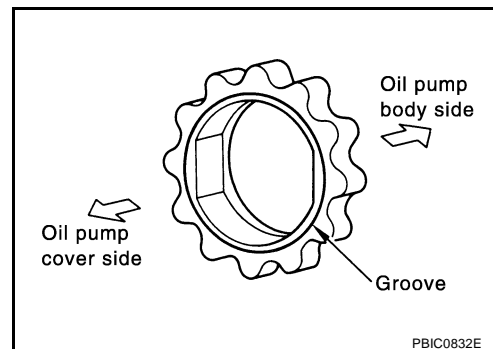

A  
LU  
C  
D  
E  
F  
G  
H  
I  
J  
K  
L  
M

# SERVICE DATA AND SPECIFICATIONS (SDS)

[VQ35DE]

## SERVICE DATA AND SPECIFICATIONS (SDS)

PFP:00030

### Standard and Limit ENGINE OIL PRESSURE

NBS00406

Unit: kPa (kg/cm<sup>2</sup>, psi)

Engine speed	Approximate discharge pressure*
Idle speed	More than 98 (1.0, 14)
2,000 rpm	More than 294 (3.0, 43)

\*: Engine oil temperature at 80°C (176°F)

### ENGINE OIL CAPACITY (APPROXIMATE)

Unit: ℓ (US qt, Imp qt)

Drain and refill	With oil filter change	4.7 (5, 4-1/8)
	Without oil filter change	4.4 (4-5/8, 3-7/8)
Dry engine (Overhaul)		5.4 (5-3/4, 4-3/4)

### OIL PUMP

Unit: mm (in)

Oil pump body to oil pump outer rotor radial clearance	0.114 - 0.260 (0.0045 - 0.0102)
Oil pump inner rotor to oil pump outer rotor tip clearance	Below 0.180 (0.0071)
Oil pump body to oil pump inner rotor axial clearance	0.030 - 0.070 (0.0012 - 0.0028)
Oil pump body to oil pump outer rotor axial clearance	0.050 - 0.110 (0.0020 - 0.0043)
Oil pump inner rotor to brazed portion of housing clearance	0.045 - 0.091 (0.0018 - 0.0036)

### REGULATOR VALVE

Unit: mm (in)

Regulator valve to oil pump cover clearance	0.040 - 0.097 (0.0016 - 0.0038)
---	---------------------------------

## PRECAUTIONS

PPF:00001

A

### Precautions for Liquid Gasket LIQUID GASKET APPLICATION PROCEDURE

NBS005SI

1. Remove old liquid gasket adhering to the liquid gasket application surface and the mating surface.
  - Remove liquid gasket completely from the liquid gasket application surface, mounting bolts, and bolt holes.
2. Wipe the liquid gasket application surface and the mating surface with white gasoline (lighting and heating use) to remove adhering moisture, grease and foreign materials.
3. Apply liquid gasket to the liquid gasket application surface.  
**Use Genuine RTV Silicone Sealant or equivalent. Refer to [GI-47, "RECOMMENDED CHEMICAL PRODUCTS AND SEALANTS"](#) .**
  - Within five minutes of liquid gasket application, install the mating component.
  - If liquid gasket protrudes, wipe it off immediately.
  - Do not retighten mounting bolts or nuts after the installation.
  - After 30 minutes or more have passed from the installation, fill engine oil and engine coolant.

LU

C

D

E

F

G

H

I

J

K

L

M

# PREPARATION

[VK45DE]

## PREPARATION

PF0:00002

### Special Service Tools

NBS004Q8

The actual shapes of Kent-Moore tools may differ from those of special service tools illustrated here.

Tool number (Kent-Moore No.) Tool name	Description
ST25051001 (J25695-1) Oil pressure gauge	Measuring oil pressure <b>Maximum measuring range:</b> 2,452 kPa (25 kg/cm <sup>2</sup> , 356 psi)
ST25052000 (J25695-2) Hose	Adapting oil pressure gauge to cylinder block
KV10115801 (J38956) Oil filter wrench	Removing and installing oil filter <b>a: 64.3 (2.531 in)</b>

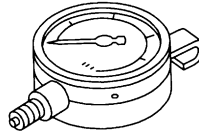

S-NT050

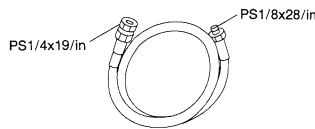

S-NT559

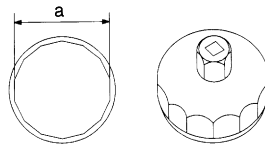

S-NT375

## Commercial Service Tools

NBS004Q9

Tool name	Description
Power tool	Loosening nuts and bolts
Deep socket	Removing and installing oil pressure switch <b>a: 26 mm (1.02 in)</b>

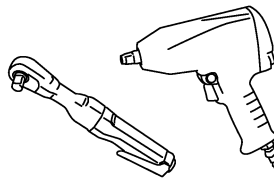

PBIC0190E

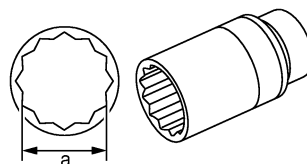

PBIC2072E



### LUBRICATION SYSTEM

PFP:15010

### Lubrication Circuit

NBS004QA

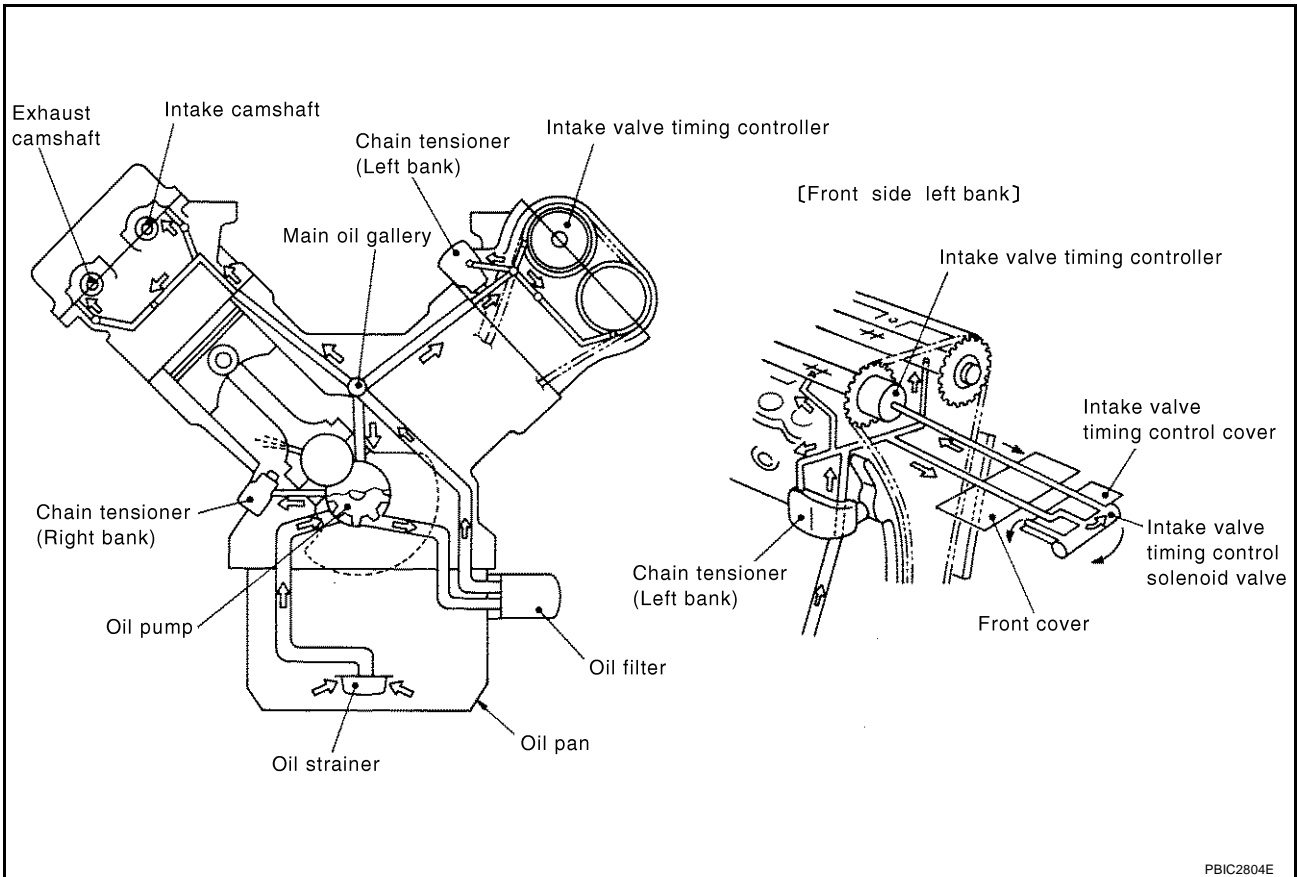

A  
LU  
C  
D  
E  
F  
G  
H  
I  
J  
K  
L  
M

# LUBRICATION SYSTEM

[VK45DE]

## System Chart

NBS004QB

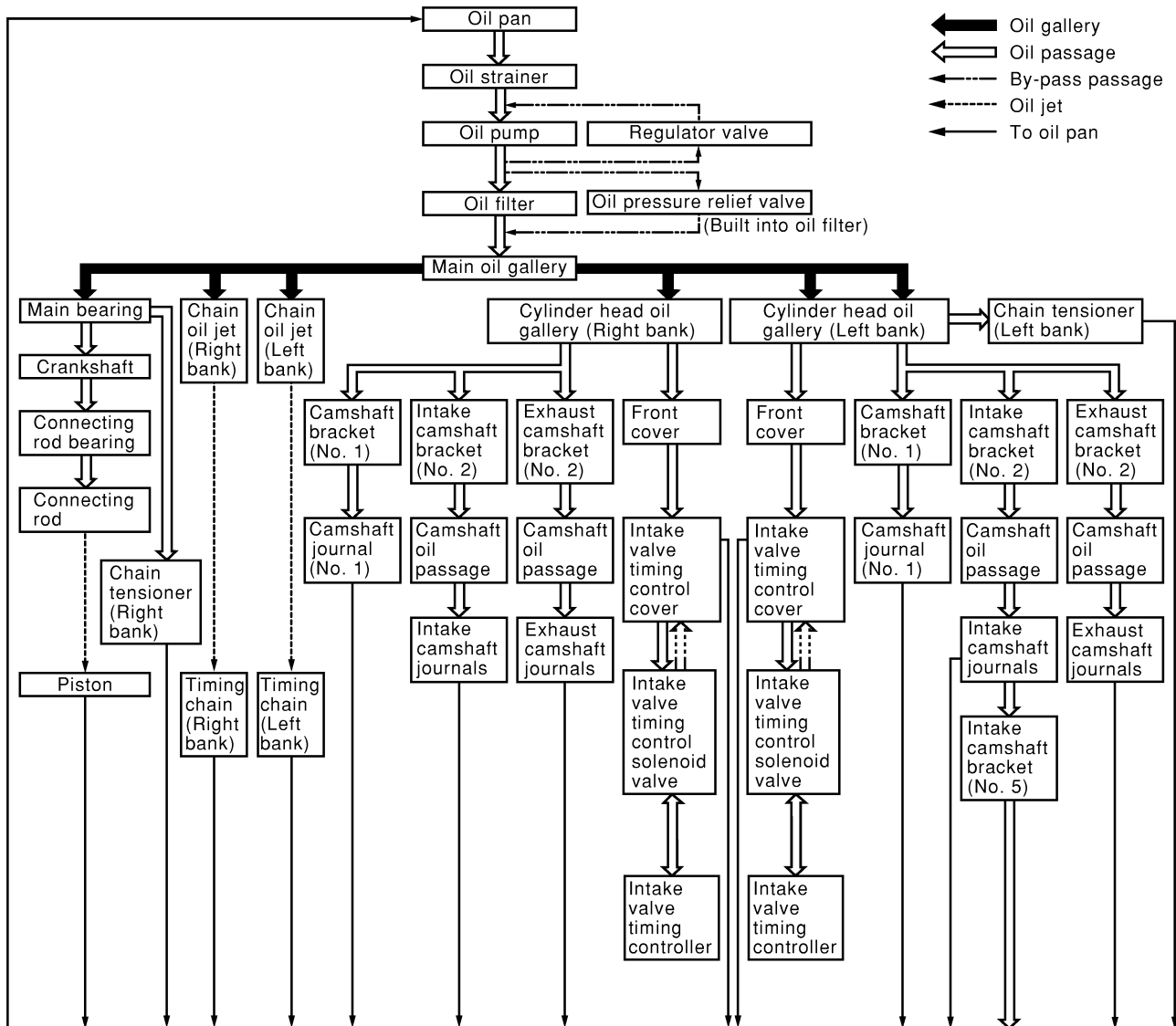

PBIC0134E

**ENGINE OIL****Inspection  
ENGINE OIL LEVEL****NOTE:**

Before starting engine, put vehicle horizontally and check the engine oil level. If engine is already started, stop it and allow 15 minutes before checking.

1. Pull out oil level gauge and wipe it clean.
2. Insert oil level gauge and make sure the engine oil level is within the range shown in the figure.
3. If it is out of range, adjust it.

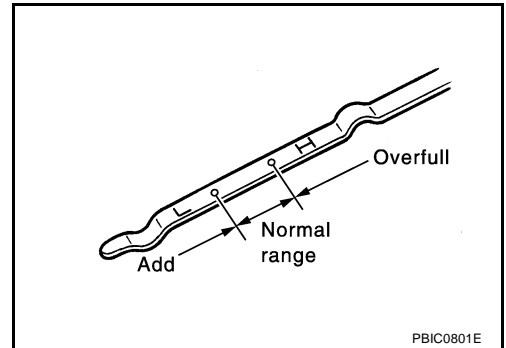
**ENGINE OIL APPEARANCE**

- Check engine oil for white turbidity or heavy contamination.
- If engine oil becomes turbid and white, it is highly probable that it is contaminated with engine coolant. Repair or replace damaged parts.

**ENGINE OIL LEAKAGE**

Check for oil leakage around the following area.

- Oil pan
- Oil pan drain plug
- Oil pressure switch
- Oil filter
- Intake valve timing control cover
- Intake valve timing control solenoid valve
- Front cover
- Chain tensioner cover
- Mating surface between cylinder block and cylinder head
- Mating surface between cylinder head and rocker cover
- Crankshaft oil seals (front and rear)

**OIL PRESSURE CHECK****WARNING:**

- Be careful not to burn yourself, as engine oil may be hot.
  - Oil pressure check should be done in "Parking position".
1. Check the engine oil level. Refer to [LU-27, "ENGINE OIL LEVEL"](#).
  2. Remove front engine undercover with power tool.
  3. Disconnect harness connector at oil pressure switch, and remove oil pressure switch using deep socket (commercial service tool).

**CAUTION:**

Do not drop or shock oil pressure switch.

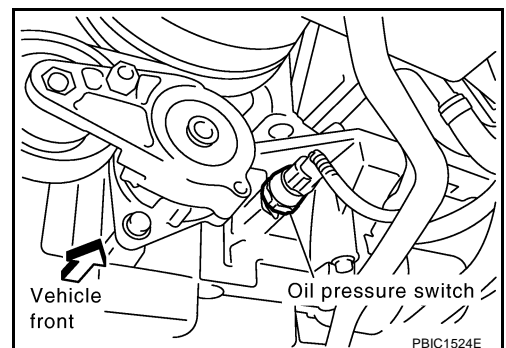

4. Install oil pressure gauge and hose (SST).

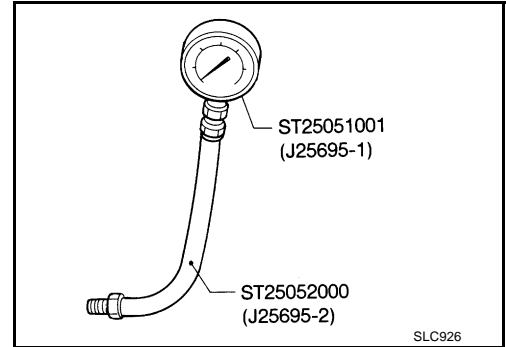

5. Start engine and warm it up to normal operating temperature.
6. Check the engine oil pressure with engine running under no-load.

**NOTE:**

When engine oil temperature is low, engine oil pressure becomes high.

**Engine oil pressure [Engine oil temperature at 80°C (176°F)]**

Unit: kPa (kg/cm<sup>2</sup> , psi)

Engine speed	Approximate discharge pressure
Idle speed	More than 98 (1.0, 14)
2,000 rpm	More than 294 (3.0, 43)

**If difference is extreme, check oil passage and oil pump for oil leaks.**

7. After the inspections, install oil pressure switch as follows:
  - a. Remove old liquid gasket adhering to oil pressure switch and engine.
  - b. Apply liquid gasket and tighten oil pressure switch to the specification.

**Use Genuine RTV Silicone Sealant or equivalent. Refer to [GI-47, "RECOMMENDED CHEMICAL PRODUCTS AND SEALANTS"](#) .**

: **14.8 N·m (1.5 kg-m, 11 ft-lb)**

- c. After warming up engine, make sure there is no leakage of engine oil with running engine.

## Changing Engine Oil

NBS004QD

**WARNING:**

- Be careful not to burn yourself, as engine oil may be hot.
  - Prolonged and repeated contact with used engine oil may cause skin cancer. Try to avoid direct skin contact with used engine oil. If skin contact is made, wash thoroughly with soap or hand cleaner as soon as possible.
1. Warm up engine, put vehicle horizontally and check for engine oil leakage from engine components. Refer to [LU-27, "ENGINE OIL LEAKAGE"](#) .
  2. Stop engine and wait for 15 minutes.
  3. Loosen oil filler cap.

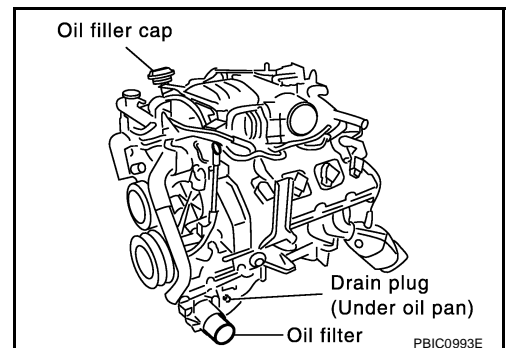

4. Remove mounting bolts, and then pull down the rear of front engine undercover and secure it using clip.
5. Remove drain plug and then drain engine oil.

6. Install drain plug with new washer. Refer to [EM-187, "OIL PAN AND OIL STRAINER"](#) .

**CAUTION:**

**Be sure to clean drain plug and install with new washer.**

**Oil pan drain plug:**

 : **34.3 N-m (3.5 kg-m, 25 ft-lb)**

7. Refill with new engine oil.

**Engine oil specification and viscosity:**

Refer to [MA-12, "RECOMMENDED FLUIDS AND LUBRICANTS"](#) .

**Engine oil capacity (Approximate):**

Unit: ℓ (US qt, Imp qt)

Drain and refill	With oil filter change	5.5 (5-3/4, 4-7/8)
	Without oil filter change	4.9 (5-1/8, 4-1/4)
Dry engine (engine overhaul)		6.7 (7-1/8, 5-7/8)

**CAUTION:**

- **The refill capacity depends on the engine oil temperature and drain time. Use these specifications for reference only.**
  - **Always use oil level gauge to determine the proper amount of engine oil in engine.**
8. Warm up engine and check area around drain plug and oil filter for oil leakage.
9. Stop engine and wait for 15 minutes.
10. Check the engine oil level. Refer to [LU-27, "ENGINE OIL LEVEL"](#) .

## OIL FILTER

### Removal and Installation

#### REMOVAL

1. Remove front engine undercover with power tool.
2. Using the oil filter wrench (SST), remove the oil filter.

**CAUTION:**

- Oil filter is provided with relief valve. Use Genuine Nissan Oil Filter or equivalent.
- Be careful not to get burned when engine and engine oil may be hot.
- When removing, prepare a shop cloth to absorb any engine oil leakage or spillage.
- Do not allow engine oil to adhere to drive belts.
- Completely wipe off any engine oil that adhere to engine and vehicle.

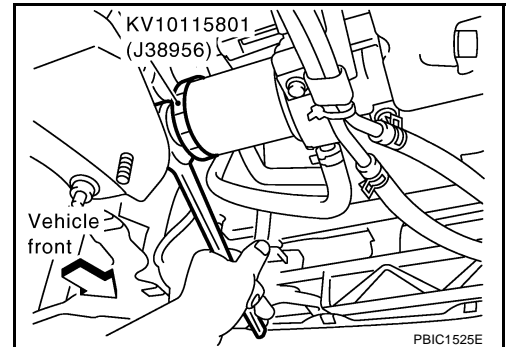

#### INSTALLATION

1. Remove foreign materials adhering to oil filter installation surface.
2. Apply new engine oil to the oil seal circumference of the new oil filter.

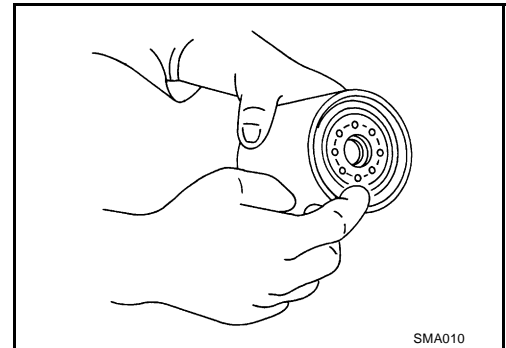

3. Screw oil filter manually until it touches the installation surface, then tighten it by 2/3 turn. Or tighten to specification.

**Oil filter:**

 :17.7 N·m (1.8 kg-m, 13 ft-lb)

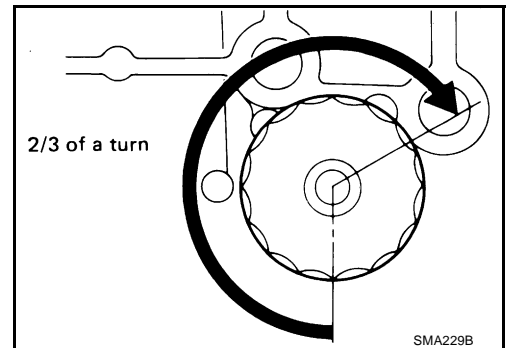

#### INSPECTION AFTER INSTALLATION

1. Check the engine oil level. Refer to [LU-27, "ENGINE OIL"](#) .
2. Start engine, and check there is no leaks of engine oil.
3. Stop engine and wait for 15 minutes.
4. Check the engine oil level and adjust engine oil. Refer to [LU-27, "ENGINE OIL"](#) .

## OIL PUMP

PFP:15010

### Components

NBS004QF

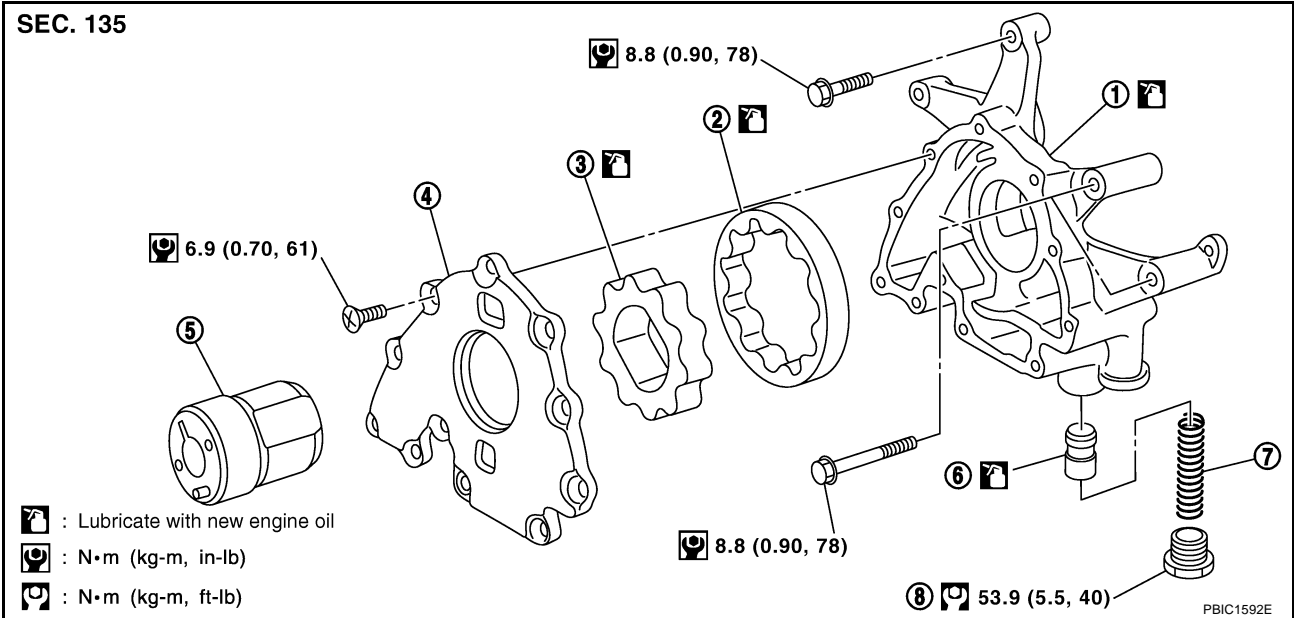

- |                           |                          |                         |
|---------------------------|--------------------------|-------------------------|
| 1. Oil pump body          | 2. Oil pump outer rotor  | 3. Oil pump inner rotor |
| 4. Oil pump cover         | 5. Oil pump drive spacer | 6. Regulator valve      |
| 7. Regulator valve spring | 8. Regulator valve plug  |                         |

### Removal and Installation

#### REMOVAL

- Remove engine assembly from vehicle. Refer to [EM-247, "ENGINE ASSEMBLY"](#).
- Remove front cover. Refer to [EM-203, "TIMING CHAIN"](#).
- Remove oil pump drive spacer.
  - Set bolts in the two bolt holes [M6 × pitch 1.0 mm (0.04 in)] on the front surface. Using suitable puller, pull oil pump drive spacer off from crankshaft.

**NOTE:**

The dimension between the centers of the two bolt holes is 33 mm (1.30 in).  
In the figure, a commercial steering puller is used.

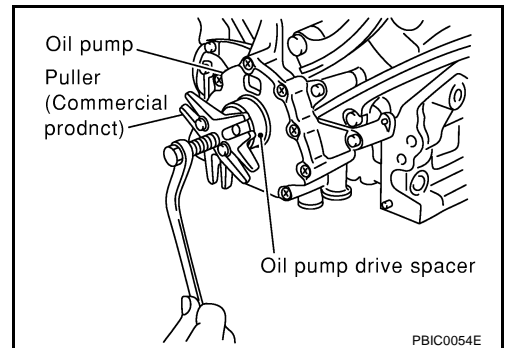

- Remove oil pump.

#### INSTALLATION

- Install the oil pump.
- Install oil pump drive spacer as follows:
  - Insert oil pump drive spacer according to the directions of crankshaft key and the two flat surfaces of oil pump inner rotor.
    - If the positional relationship does not allow the insertion, rotate oil pump inner rotor with a finger to allow spacer.
  - After confirming that the position of each part is in correct condition to allow for spacer, force fit spacer by lightly tapping with plastic hammer until it contacts and does not go further.

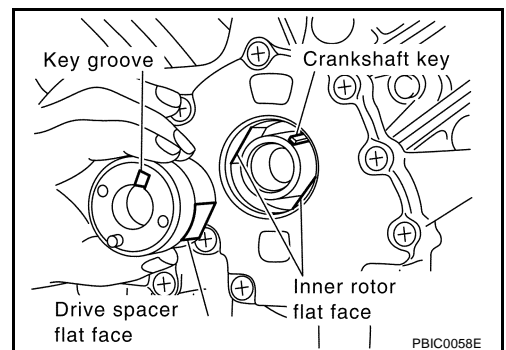

3. Install in the reverse order of removal after this step.

## INSPECTION AFTER INSTALLATION

1. Check the engine oil level. Refer to [LU-27, "ENGINE OIL"](#) .
2. Start engine, and check there is no leak of engine oil.
3. Stop engine and wait for 15 minutes.
4. Check the engine oil level and adjust engine oil. Refer to [LU-27, "ENGINE OIL"](#) .

## Disassembly and Assembly

### DISASSEMBLY

NBS004QH

1. Remove oil pump cover.
2. Remove oil pump inner rotor and oil pump outer rotor from oil pump body.
3. After removing regulator valve plug, remove regulator valve spring and regulator valve.

## INSPECTION AFTER DISASSEMBLY

### Oil Pump Clearance

- Measure the clearance with feeler gauge.
  - Clearance between oil pump outer rotor and oil pump body (Position 1)
 

**Standard : 0.114 - 0.200 mm (0.0045 - 0.0079 in)**
  - Tip clearance between oil pump inner rotor and oil pump outer rotor (Position 2)
 

**Standard : Below 0.180 mm (0.0071 in)**
  - If out of the standard, replace inner rotor and outer rotor.

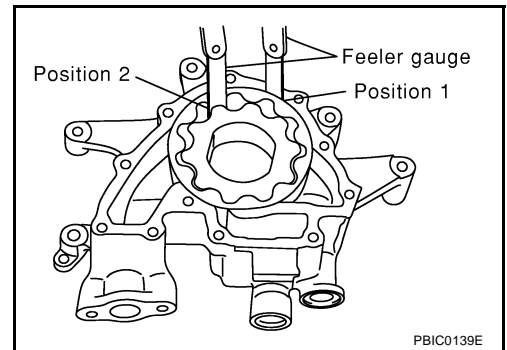

- Measure the clearance with feeler gauge and straightedge.
  - Side clearance between oil pump inner rotor and oil pump body (Position 3)
 

**Standard : 0.030 - 0.070 mm (0.0012 - 0.0028 in)**
  - Side clearance between oil pump outer rotor and oil pump body (Position 4)
 

**Standard : 0.030 - 0.090 mm (0.0012 - 0.0035 in)**

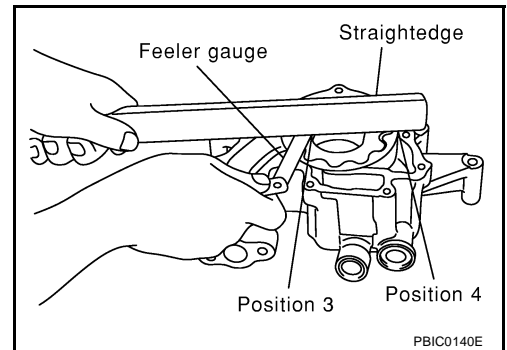

- Calculate the clearance between oil pump inner rotor and oil pump body as follows:

### OIL PUMP INNER ROTOR OUTER DIAMETER

- Measure the outer diameter of protruded portion of oil pump inner rotor with micrometer. (Position 5)

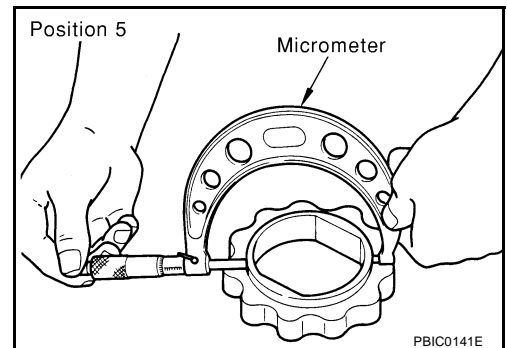



## OIL PUMP BODY INNER DIAMETER

- Measure the inner diameter of oil pump body with inside micrometer. (Position 6)

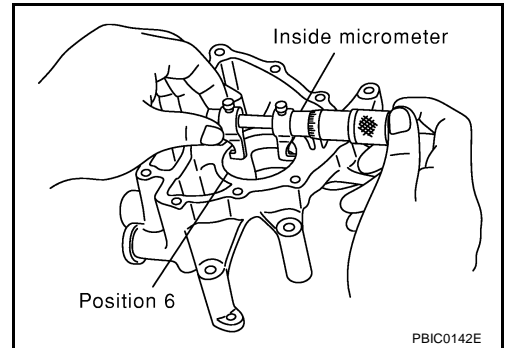

## OIL PUMP INNER DIAMETER TO OIL PUMP BODY CLEARANCE

- (Clearance) = (Oil pump body inner diameter) – (Oil pump inner rotor outer diameter)

**Standard : 0.045 - 0.091 mm (0.0018 - 0.0036 in)**

- If the measured/calculated values are out of the standard, replace oil pump assembly.

## Regulator Valve Clearance

(Clearance) = D1 (Valve hole diameter) – D2 (Regulator valve outer diameter of valve)

**Standard : 0.040 - 0.097 mm (0.0016 - 0.0038 in)**

- If the calculated value is out of the standard, replace oil pump assembly.

### CAUTION:

- Coat regulator valve with engine oil.
- Make sure that it falls smoothly into regulator valve hole by its own weight.

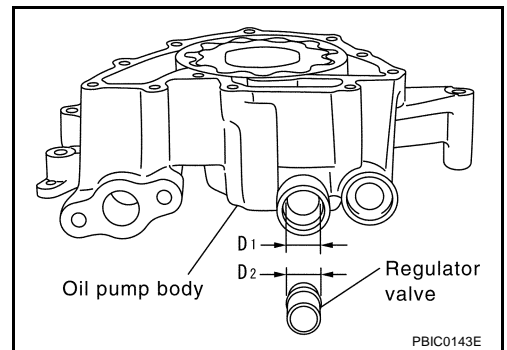

## ASSEMBLY

Note the following, and assemble in the reverse order of disassembly.

- Install oil pump inner rotor and oil pump outer rotor with the punched marks on the oil pump cover side.

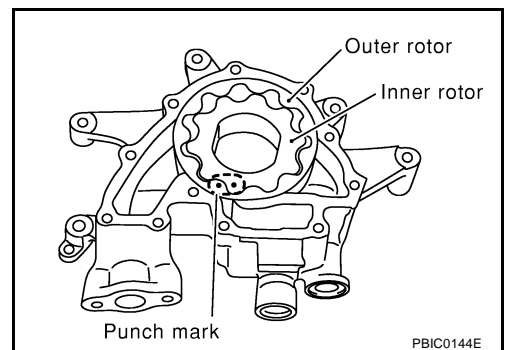

A  
LU  
C  
D  
E  
F  
G  
H  
I  
J  
K  
L  
M

# SERVICE DATA AND SPECIFICATIONS (SDS)

[VK45DE]

## SERVICE DATA AND SPECIFICATIONS (SDS)

PFP:00030

### Standard and Limit ENGINE OIL PRESSURE

NBS00401

Unit: kPa (kg/cm<sup>2</sup> /psi)

Engine speed	Approximate discharge oil pressure*
Idle speed	More than 98 (1.0, 14)
2,000 rpm	More than 294 (3.0, 43)

\*: Engine oil temperature at 80°C (176°F)

### ENGINE OIL CAPACITY (APPROXIMATE)

Unit: ℓ (US qt, Imp qt)

Drain and refill	With oil filter change	5.5 (5-3/4, 4-7/8)
	Without oil filter change	4.9 (5-1/8, 4-1/4)
Dry engine (engine overhaul)		6.7 (7-1/8, 5-7/8)

### OIL PUMP

Unit: mm (in)

Oil pump body to oil pump outer rotor radial clearance	0.114 - 0.200 (0.0045 - 0.0079)
Oil pump inner rotor to oil pump outer rotor tip clearance	Below 0.180 (0.0071)
Oil pump body to oil pump inner rotor axial clearance	0.030 - 0.070 (0.0012 - 0.0028)
Oil pump body to oil pump outer rotor axial clearance	0.030 - 0.090 (0.0012 - 0.0035)
Oil pump inner rotor to oil pump body clearance	0.045 - 0.091 (0.0018 - 0.0036)

### REGULATOR VALVE

Unit: mm (in)

Regulator valve to oil pump body clearance	0.040 - 0.097 (0.0016 - 0.0038)
--	---------------------------------