

SECTION **SE**  
SEAT

A  
B  
C

CONTENTS

D  
E

<b>PRECAUTIONS</b> .....	<b>3</b>	CAN Communication Unit .....	16	F
Precautions for Supplemental Restraint System (SRS) "AIR BAG" and "SEAT BELT PRE-TENSIONER" .....	3	Schematic .....	17	
Service Notice .....	3	Wiring Diagram — AUT/DP — .....	19	
Precautions for Work .....	3	Terminals and Reference Values for BCM .....	31	G
<b>PREPARATION</b> .....	<b>4</b>	Terminals and Reference Value for Intelligent Key Unit .....	31	
Special Service Tools .....	4	Terminals and Reference Values for Driver Seat Control Unit .....	32	H
Commercial Service Tools .....	4	Terminals and Reference Values for Automatic Drive Positioner Control Unit .....	34	
<b>SQUEAK AND RATTLE TROUBLE DIAGNOSES</b> .....	<b>5</b>	CONSULT-II Function (AUTO DRIVE POS.) .....	37	SE
Work Flow .....	5	CONSULT-II START PROCEDURE .....	37	
CUSTOMER INTERVIEW .....	5	SELF-DIAGNOSIS RESULTS .....	37	
DUPLICATE THE NOISE AND TEST DRIVE .....	6	DATA MONITOR .....	38	J
CHECK RELATED SERVICE BULLETINS .....	6	ACTIVE TEST .....	39	
LOCATE THE NOISE AND IDENTIFY THE ROOT CAUSE .....	6	WORK SUPPORT .....	39	
REPAIR THE CAUSE .....	6	Work Flow .....	40	K
CONFIRM THE REPAIR .....	7	Symptom Chart .....	40	
Generic Squeak and Rattle Troubleshooting .....	7	CAN Communication Inspection Using CONSULT-II (Self-Diagnosis) .....	42	L
INSTRUMENT PANEL .....	7	Check BCM Power Supply and Ground Circuit .....	42	
CENTER CONSOLE .....	7	Check Driver Seat Control Unit Power Supply and Ground Circuit .....	43	
DOORS .....	7	Check Automatic Drive Positioner Control Unit Power Supply and Ground Circuit .....	44	M
TRUNK .....	8	Check Sliding Motor Circuit .....	45	
SUNROOF/HEADLINING .....	8	Check Reclining Motor Circuit .....	46	
SEATS .....	8	Check Front Lifting Motor Circuit .....	47	
UNDERHOOD .....	8	Check Rear Lifting Motor Circuit .....	49	
Diagnostic Worksheet .....	9	Check Telescopic Motor Circuit .....	50	
<b>AUTOMATIC DRIVE POSITIONER</b> .....	<b>11</b>	Check Tilt Motor Circuit .....	51	
Component Parts And Harness Connector Location .....	11	Check Sliding Sensor Circuit .....	53	
System Description .....	12	Check Reclining Sensor Circuit .....	55	
MANUAL OPERATION .....	12	Check Front Lifting Sensor Circuit .....	57	
MEMORY OPERATION .....	12	Check Rear Lifting Sensor Circuit .....	59	
EXITING OPERATION .....	14	Check Telescopic Sensor Circuit .....	61	
ENTRY OPERATION .....	14	Check Tilt Sensor Circuit .....	63	
INTELLIGENT KEY INTERLOCK OPERATION..	15	Check Door Mirror Sensor LH Circuit .....	64	
FAIL-SAFE MODE .....	15	Check Door Mirror Sensor RH Circuit .....	67	
INITIALIZATION PROCEDURE .....	16	Check Sliding Switch Circuit .....	69	
SETTING CHANGE FUNCTION .....	16			
CAN Communication System Description .....	16			

Check Reclining Switch Circuit .....	71	ply Circuit .....	131
Check Lifting Switch (Front) Circuit .....	73	Check Climate Controlled Seat Switch Circuit .....	132
Check Lifting Switch (Rear) Circuit .....	75	Check Climate Controlled Seat Switch Indicator Circuit .....	134
Check Power Seat Switch Ground Circuit .....	76	Check Seat Cushion Thermal Electric Device Circuit .....	136
Check Telescopic Switch Circuit .....	77	Check Seatback Thermal Electric Device Circuit .....	137
Check Tilt Switch Circuit .....	79	Check Seat Cushion Thermal Electric Device Sensor Circuit .....	138
Check Seat Memory and Set Switch Circuit .....	81	Check Seatback Thermal Electric Device Sensor Circuit .....	140
Check Seat Memory Indicator Lamp Circuit .....	82	Check Climate Controlled Seat Blower Motor Circuit .....	141
Check Door Mirror Sensor Power Supply and Ground Circuit .....	84	Check Climate Controlled Seat Control Unit .....	143
Check A/T Device (Detention Switch) Circuit .....	86	<b>HEATED SEAT .....</b>	<b>144</b>
Check Front Door Switch (Driver Side) Circuit .....	87	Component Parts and Harness Connector Location .....	144
Check UART Communication Line Circuit .....	88	System Description .....	144
Check Lumbar Support Circuit .....	90	Schematic .....	146
<b>POWER SEAT(PASSENGER SIDE) .....</b>	<b>92</b>	Wiring Diagram — HSEAT — .....	147
Schematic .....	92	Terminals and Reference Values for Rear Seat Control Unit .....	152
Wiring Diagram — SEAT — .....	93	Work Flow .....	152
<b>POWER SEAT(REAR) .....</b>	<b>96</b>	Trouble Diagnoses Symptom Chart .....	152
Component Parts and Harness Connector Location .....	96	Check Rear Heated Seat Power Supply and Ground Circuit .....	153
System Description .....	96	Check Rear Seat Control Unit Power Supply and Ground Circuit .....	154
REAR POWER SEAT LH AND RH OPERATION .....	96	Check Rear Heated Seat Switch Circuit .....	156
REAR SEAT RETREAT FUNCTION .....	97	Check Rear Heated Seat Indicator Power Supply Circuit .....	158
Schematic .....	98	Check Rear Heated Seat Indicator Circuit .....	159
Wiring Diagram — R/SEAT — .....	99	Check Rear Heated Seat Circuit .....	161
Terminals and Reference Values for Rear Seat Control Unit .....	103	Check Rear Seatback Heater Circuit .....	162
Work Flow .....	104	<b>FRONT SEAT .....</b>	<b>164</b>
Trouble Diagnoses Symptom Chart .....	104	Driver's Seat Components .....	164
Check Rear Power Seat Power Supply Circuit .....	104	Passenger's Seat Components .....	166
Check Rear Seat Control Unit Power Supply and Ground Circuit .....	105	Removal and Installation .....	168
Check Rear Seat Sliding Motor Circuit .....	106	REMOVAL .....	168
Check Rear Power Seat Switch Circuit .....	107	INSTALLATION .....	168
Check Automatic Return Cancel Switch Circuit .....	109	Disassembly and Assembly .....	169
Check Automatic Return Cancel Switch .....	110	SEATBACK .....	169
Check Rear Door Switch Circuit .....	111	SEAT CUSHION .....	170
Check Rear Seat Sliding Sensor Circuit .....	112	CLIMATE CONTROLLED SEAT .....	172
<b>CLIMATE CONTROLLED SEAT .....</b>	<b>114</b>	<b>REAR SEAT .....</b>	<b>173</b>
Component Parts and Harness Connector Location .....	114	Bench Seat Components .....	173
System Description .....	114	Power Seat (Split Type) Components .....	175
Schematic .....	118	Removal and Installation .....	177
Wiring Diagram — C/SEAT — .....	119	BENCH SEAT .....	177
Terminal and Reference Value for Climate Controlled Seat Control Unit .....	124	POWER SEAT .....	177
Work Flow .....	125	Disassembly and Assembly .....	178
Trouble Diagnoses Symptom Chart .....	126	BENCH SEAT .....	178
Preliminary Check .....	126	POWER SEAT .....	180
Check Climate Controlled Seat Control Unit Power Supply Circuit .....	127		
Check Climate Controlled Seat Control Unit Power Supply and Ground Circuit .....	128		
Check Climate Controlled Seat Switch Power Supply Circuit .....			

# PRECAUTIONS

## PRECAUTIONS

PFPP:00001

### Precautions for Supplemental Restraint System (SRS) “AIR BAG” and “SEAT BELT PRE-TENSIONER”

NIS0025I

The Supplemental Restraint System such as “AIR BAG” and “SEAT BELT PRE-TENSIONER”, used along with a front seat belt, helps to reduce the risk or severity of injury to the driver and front passenger for certain types of collision. This system includes seat belt switch inputs and dual stage front air bag modules. The SRS system uses the seat belt switches to determine the front air bag deployment, and may only deploy one front air bag, depending on the severity of a collision and whether the front occupants are belted or unbelted. Information necessary to service the system safely is included in the SRS and SB section of this Service Manual.

#### **WARNING:**

- To avoid rendering the SRS inoperative, which could increase the risk of personal injury or death in the event of a collision which would result in air bag inflation, all maintenance must be performed by an authorized NISSAN/INFINITI dealer.
- Improper maintenance, including incorrect removal and installation of the SRS, can lead to personal injury caused by unintentional activation of the system. For removal of Spiral Cable and Air Bag Module, see the SRS section.
- Do not use electrical test equipment on any circuit related to the SRS unless instructed to in this Service Manual. SRS wiring harnesses can be identified by yellow and/or orange harnesses or harness connectors.

#### **Service Notice**

NIS0025J

- When removing or installing various parts, place a cloth or padding onto the vehicle body to prevent scratches.
- Handle trim, molding, instruments, grille, etc. carefully during removing or installing. Be careful not to oil or damage them.
- Apply sealing compound where necessary when installing parts.
- When applying sealing compound, be careful that the sealing compound does not protrude from parts.
- When replacing any metal parts (for example body outer panel, members, etc.), be sure to take rust prevention measures.

#### **Precautions for Work**

NIS0025K

- When removing or disassembling each component, be careful not to damage or deform it. If a component may be subject to interference, be sure to protect it with a shop cloth.
- When removing (disengaging) components with a screwdriver or similar tool, be sure to wrap the component with a shop cloth or vinyl tape to protect it.
- Protect the removed parts with a shop cloth and keep them.
- Replace a deformed or damaged clip.
- If a part is specified as a non-reusable part, always replace it with new one.
- Be sure to tighten bolts and nuts securely to the specified torque.
- After re-installation is completed, be sure to check that each part works normally.
- Follow the steps below to clean components.
  - Water soluble foul: Dip a soft cloth into lukewarm water, and wring the water out of the cloth to wipe the fouled area.  
Then rub with a soft and dry cloth.
  - Oily foul: Dip a soft cloth into lukewarm water with mild detergent (concentration: within 2 to 3%), and wipe the fouled area.  
Then dip a cloth into fresh water, and wring the water out of the cloth to wipe the detergent off. Then rub with a soft and dry cloth.
- Do not use organic solvent such as thinner, benzene, alcohol, and gasoline.
- For genuine leather seats, use a genuine leather seat cleaner.

# PREPARATION

## PREPARATION

PFP:00002

### Special Service Tools

NIS0025L

The actual shapes of Kent-Moore tools may differ from those of special service tools illustrated here.

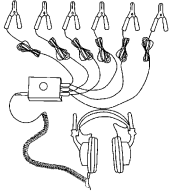
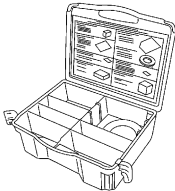
Tool number (Kent-Moore No.) Tool name	Description
(J39570) Chassis ear   SIIA0993E	Locating the noise
(J43980) NISSAN Squeak and Rattle Kit   SIIA0994E	Repairing the cause of noise

### Commercial Service Tools

NIS0025M

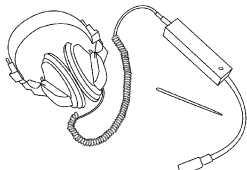
Tool name	Description
Engine ear   SIIA0995E	Locating the noise

# SQUEAK AND RATTLE TROUBLE DIAGNOSES

## SQUEAK AND RATTLE TROUBLE DIAGNOSES

PFP:00000

### Work Flow

NIS0028W

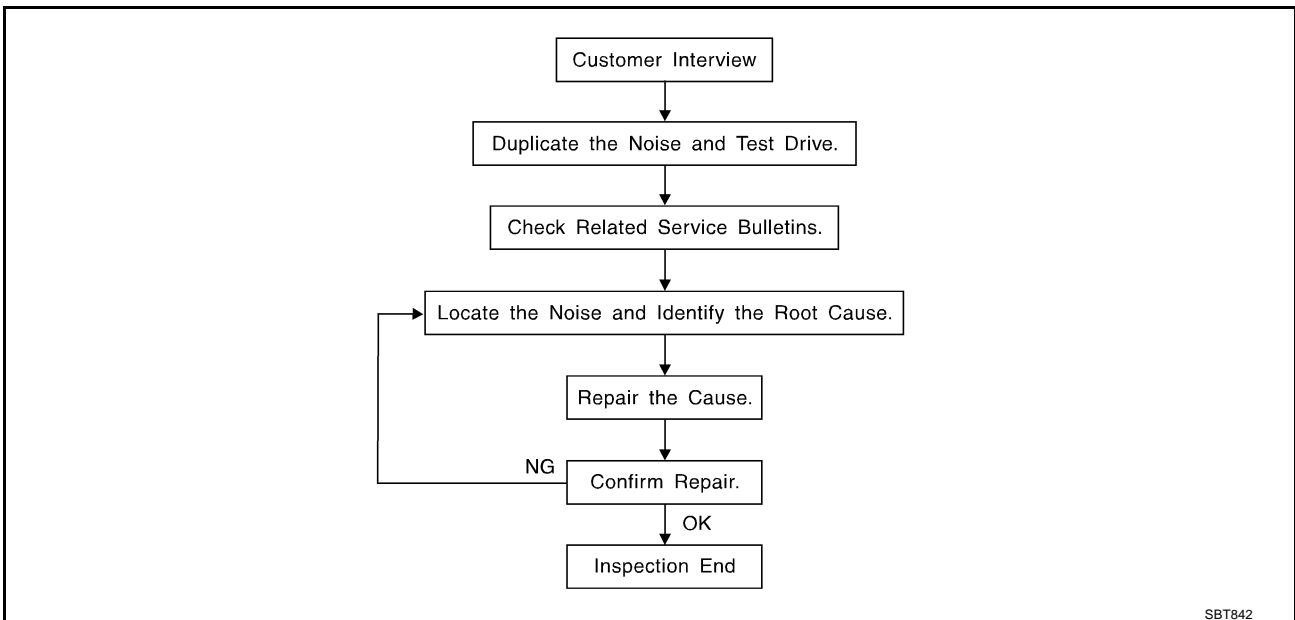

### CUSTOMER INTERVIEW

Interview the customer if possible, to determine the conditions that exist when the noise occurs. Use the Diagnostic Worksheet during the interview to document the facts and conditions when the noise occurs and any customer's comments; refer to [SE-9, "Diagnostic Worksheet"](#). This information is necessary to duplicate the conditions that exist when the noise occurs.

- The customer may not be able to provide a detailed description or the location of the noise. Attempt to obtain all the facts and conditions that exist when the noise occurs (or does not occur).
- If there is more than one noise in the vehicle, be sure to diagnose and repair the noise that the customer is concerned about. This can be accomplished by test driving the vehicle with the customer.
- After identifying the type of noise, isolate the noise in terms of its characteristics. The noise characteristics are provided so the customer, service adviser and technician are all speaking the same language when defining the noise.
- Squeak—(Like tennis shoes on a clean floor)  
Squeak characteristics include the light contact/fast movement/brought on by road conditions/hard surfaces=higher pitch noise/softer surfaces=lower pitch noises/edge to surface=chirping
- Creak—(Like walking on an old wooden floor)  
Creak characteristics include firm contact/slow movement/twisting with a rotational movement/pitch dependent on materials/often brought on by activity.
- Rattle—(Like shaking a baby rattle)  
Rattle characteristics include the fast repeated contact/vibration or similar movement/loose parts/missing clip or fastener/incorrect clearance.
- Knock—(Like a knock on a door)  
Knock characteristics include hollow sounding/sometimes repeating/often brought on by driver action.
- Tick—(Like a clock second hand)  
Tick characteristics include gentle contacting of light materials/loose components/can be caused by driver action or road conditions.
- Thump—(Heavy, muffled knock noise)  
Thump characteristics include softer knock/dead sound often brought on by activity.
- Buzz—(Like a bumble bee)  
Buzz characteristics include high frequency rattle/firm contact.
- Often the degree of acceptable noise level will vary depending upon the person. A noise that you may judge as acceptable may be very irritating to the customer.
- Weather conditions, especially humidity and temperature, may have a great effect on noise level.

# SQUEAK AND RATTLE TROUBLE DIAGNOSES

## DUPLICATE THE NOISE AND TEST DRIVE

If possible, drive the vehicle with the customer until the noise is duplicated. Note any additional information on the Diagnostic Worksheet regarding the conditions or location of the noise. This information can be used to duplicate the same conditions when you confirm the repair.

If the noise can be duplicated easily during the test drive, to help identify the source of the noise, try to duplicate the noise with the vehicle stopped by doing one or all of the following:

- 1) Close a door.
  - 2) Tap or push/pull around the area where the noise appears to be coming from.
  - 3) Rev the engine.
  - 4) Use a floor jack to recreate vehicle "twist".
  - 5) At idle, apply engine load (electrical load, half-clutch on M/T models, drive position on A/T models).
  - 6) Raise the vehicle on a hoist and hit a tire with a rubber hammer.
- Drive the vehicle and attempt to duplicate the conditions the customer states exist when the noise occurs.
  - If it is difficult to duplicate the noise, drive the vehicle slowly on an undulating or rough road to stress the vehicle body.

## CHECK RELATED SERVICE BULLETINS

After verifying the customer concern or symptom, check ASIST for Technical Service Bulletins (TSBs) related to that concern or symptom.

If a TSB relates to the symptom, follow the procedure to repair the noise.

## LOCATE THE NOISE AND IDENTIFY THE ROOT CAUSE

1. Narrow down the noise to a general area. To help pinpoint the source of the noise, use a listening tool (Chassis Ear: J-39570, Engine Ear and mechanics stethoscope).
2. Narrow down the noise to a more specific area and identify the cause of the noise by:
  - removing the components in the area that you suspect the noise is coming from.  
Do not use too much force when removing clips and fasteners, otherwise clips and fastener can be broken or lost during the repair, resulting in the creation of new noise.
  - tapping or pushing/pulling the component that you suspect is causing the noise.  
Do not tap or push/pull the component with excessive force, otherwise the noise will be eliminated only temporarily.
  - feeling for a vibration with your hand by touching the component(s) that you suspect is (are) causing the noise.
  - placing a piece of paper between components that you suspect are causing the noise.
  - looking for loose components and contact marks.  
Refer to [SE-7, "Generic Squeak and Rattle Troubleshooting"](#) .

## REPAIR THE CAUSE

- If the cause is a loose component, tighten the component securely.
- If the cause is insufficient clearance between components:
  - separate components by repositioning or loosening and retightening the component, if possible.
  - insulate components with a suitable insulator such as urethane pads, foam blocks, felt cloth tape or urethane tape. A Nissan Squeak and Rattle Kit (J-43980) is available through your authorized Nissan Parts Department.

### CAUTION:

**Do not use excessive force as many components are constructed of plastic and may be damaged.**

### NOTE:

Always check with the Parts Department for the latest parts information.

The following materials are contained in the Nissan Squeak and Rattle Kit (J-43980). Each item can be ordered separately as needed.

URETHANE PADS [1.5 mm (0.059 in) thick]

Insulates connectors, harness, etc.

76268-9E005: 100 × 135 mm (3.94 × 5.31 in)/76884-71L01: 60 × 85 mm (2.36 × 3.35 in)/76884-

71L02: 15 × 25 mm (0.59 × 0.98 in)

INSULATOR (Foam blocks)

Insulates components from contact. Can be used to fill space behind a panel.

73982-9E000: 45 mm (1.77 in) thick, 50 × 50 mm (1.97 × 1.97 in)/73982-

50Y00: 10 mm (0.39 in) thick, 50 × 50 mm (1.97 × 1.97 in)

# SQUEAK AND RATTLE TROUBLE DIAGNOSES

INSULATOR (Light foam block)

80845-71L00: 30 mm (1.18 in) thick, 30 × 50 mm (1.18 × 1.97 in)

FELT CLOTHTAPE

Used to insulate where movement does not occur. Ideal for instrument panel applications.

68370-4B000: 15 × 25 mm (0.59 × 0.98 in) pad/68239-13E00: 5 mm (0.20 in) wide tape roll

The following materials, not found in the kit, can also be used to repair squeaks and rattles.

UHMW (TEFLON) TAPE

Insulates where slight movement is present. Ideal for instrument panel applications.

SILICONE GREASE

Used in place of UHMW tape that will be visible or not fit. Will only last a few months.

SILICONE SPRAY

Use when grease cannot be applied.

DUCT TAPE

Use to eliminate movement.

## CONFIRM THE REPAIR

Confirm that the cause of a noise is repaired by test driving the vehicle. Operate the vehicle under the same conditions as when the noise originally occurred. Refer to the notes on the Diagnostic Worksheet.

## Generic Squeak and Rattle Troubleshooting

NIS0028X

Refer to Table of Contents for specific component removal and installation information.

## INSTRUMENT PANEL

Most incidents are caused by contact and movement between:

1. The cluster lid A and instrument panel
2. Acrylic lens and combination meter housing
3. Instrument panel to front pillar garnish
4. Instrument panel to windshield
5. Instrument panel mounting pins
6. Wiring harnesses behind the combination meter
7. A/C defroster duct and duct joint

These incidents can usually be located by tapping or moving the components to duplicate the noise or by pressing on the components while driving to stop the noise. Most of these incidents can be repaired by applying felt cloth tape or silicon spray (in hard to reach areas). Urethane pads can be used to insulate wiring harness.

### CAUTION:

**Do not use silicone spray to isolate a squeak or rattle. If you saturate the area with silicone, you will not be able to recheck the repair.**

## CENTER CONSOLE

Components to pay attention to include:

1. Shifter assembly cover to finisher
2. A/C control unit and cluster lid C
3. Wiring harnesses behind audio and A/C control unit

The instrument panel repair and isolation procedures also apply to the center console.

## DOORS

Pay attention to the:

1. Finisher and inner panel making a slapping noise
2. Inside handle escutcheon to door finisher
3. Wiring harnesses tapping
4. Door striker out of alignment causing a popping noise on starts and stops

Tapping or moving the components or pressing on them while driving to duplicate the conditions can isolate many of these incidents. You can usually insulate the areas with felt cloth tape or insulator foam blocks from the Nissan Squeak and Rattle Kit (J-43980) to repair the noise.

# SQUEAK AND RATTLE TROUBLE DIAGNOSES

---

## TRUNK

Trunk noises are often caused by a loose jack or loose items put into the trunk by the owner. In addition look for:

1. Trunk lid dumpers out of adjustment
2. Trunk lid striker out of adjustment
3. The trunk lid torsion bars knocking together
4. A loose license plate or bracket

Most of these incidents can be repaired by adjusting, securing or insulating the item(s) or component(s) causing the noise.

## SUNROOF/HEADLINING

Noises in the sunroof/headlining area can often be traced to one of the following:

1. Sunroof lid, rail, linkage or seals making a rattle or light knocking noise
2. Sunvisor shaft shaking in the holder
3. Front or rear windshield touching headlining and squeaking

Again, pressing on the components to stop the noise while duplicating the conditions can isolate most of these incidents. Repairs usually consist of insulating with felt cloth tape.

## SEATS

When isolating seat noise it's important to note the position the seat is in and the load placed on the seat when the noise is present. These conditions should be duplicated when verifying and isolating the cause of the noise.

Cause of seat noise include:

1. Headrest rods and holder
2. A squeak between the seat pad cushion and frame
3. The rear seatback lock and bracket

These noises can be isolated by moving or pressing on the suspected components while duplicating the conditions under which the noise occurs. Most of these incidents can be repaired by repositioning the component or applying urethane tape to the contact area.

## UNDERHOOD

Some interior noise may be caused by components under the hood or on the engine wall. The noise is then transmitted into the passenger compartment.

Causes of transmitted underhood noise include:

1. Any component mounted to the engine wall
2. Components that pass through the engine wall
3. Engine wall mounts and connectors
4. Loose radiator mounting pins
5. Hood bumpers out of adjustment
6. Hood striker out of adjustment

These noises can be difficult to isolate since they cannot be reached from the interior of the vehicle. The best method is to secure, move or insulate one component at a time and test drive the vehicle. Also, engine RPM or load can be changed to isolate the noise. Repairs can usually be made by moving, adjusting, securing, or insulating the component causing the noise.



# SQUEAK AND RATTLE TROUBLE DIAGNOSES

## Diagnostic Worksheet

NIS0028Y



INFINITI.

### SQUEAK & RATTLE DIAGNOSTIC WORKSHEET

A  
B  
C  
D  
E  
F  
G  
H  
SE  
J  
K  
L  
M

Dear Infiniti Customer:

We are concerned about your satisfaction with your Infiniti vehicle. Repairing a squeak or rattle sometimes can be very difficult. To help us fix your Infiniti right the first time, please take a moment to note the area of the vehicle where the squeak or rattle occurs and under what conditions. You may be asked to take a test drive with a service consultant or technician to ensure we confirm the noise you are hearing.

#### I. WHERE DOES THE NOISE COME FROM? (circle the area of the vehicle)

The illustrations are for reference only, and may not reflect the actual configuration of your vehicle.

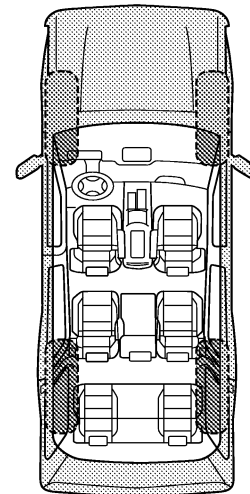
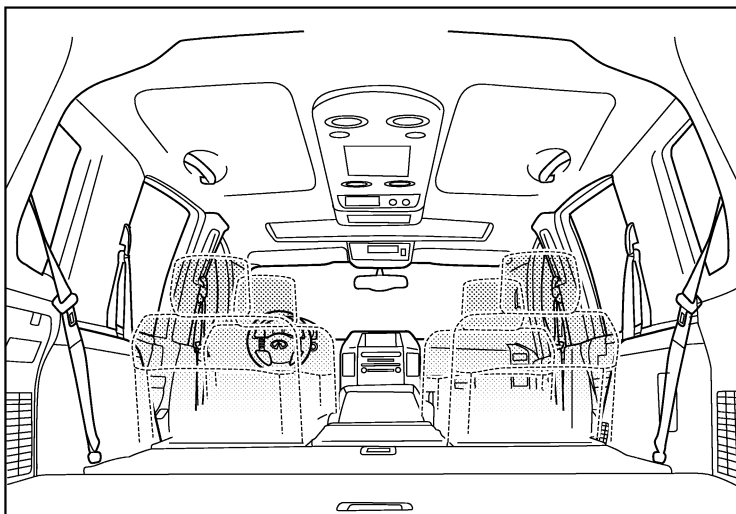
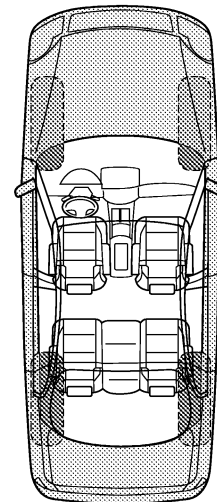
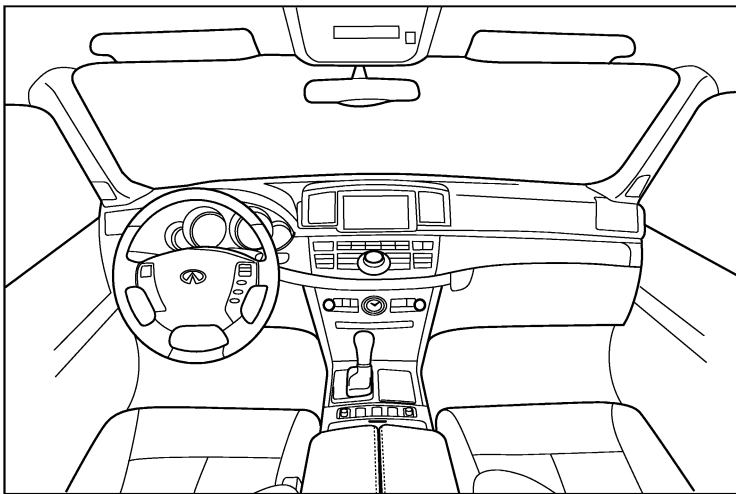

Continue to page 2 of the worksheet and briefly describe the location of the noise or rattle. In addition, please indicate the conditions which are present when the noise occurs.

PIIB8741E

# SQUEAK AND RATTLE TROUBLE DIAGNOSES

## SQUEAK & RATTLE DIAGNOSTIC WORKSHEET - page 2

Briefly describe the location where the noise occurs:

---

---

### II. WHEN DOES IT OCCUR? (please check the boxes that apply)

- |                                                       |                                                        |
|-------------------------------------------------------|--------------------------------------------------------|
| <input type="checkbox"/> anytime                      | <input type="checkbox"/> after sitting out in the rain |
| <input type="checkbox"/> 1st time in the morning      | <input type="checkbox"/> when it is raining or wet     |
| <input type="checkbox"/> only when it is cold outside | <input type="checkbox"/> dry or dusty conditions       |
| <input type="checkbox"/> only when it is hot outside  | <input type="checkbox"/> other:                        |

### III. WHEN DRIVING:

- through driveways
- over rough roads
- over speed bumps
- only about \_\_\_\_ mph
- on acceleration
- coming to a stop
- on turns: left, right or either (circle)
- with passengers or cargo
- other: \_\_\_\_\_
- after driving \_\_\_\_ miles or \_\_\_\_ minutes

### IV. WHAT TYPE OF NOISE

- squeak (like tennis shoes on a clean floor)
- creak (like walking on an old wooden floor)
- rattle (like shaking a baby rattle)
- knock (like a knock at the door)
- tick (like a clock second hand)
- thump (heavy, muffled knock noise)
- buzz (like a bumble bee)

## TO BE COMPLETED BY DEALERSHIP PERSONNEL

### Test Drive Notes:

---

---

---

	YES	NO	Initials of person performing
Vehicle test driven with customer	<input type="checkbox"/>	<input type="checkbox"/>	_____
- Noise verified on test drive	<input type="checkbox"/>	<input type="checkbox"/>	_____
- Noise source located and repaired	<input type="checkbox"/>	<input type="checkbox"/>	_____
- Follow up test drive performed to confirm repair	<input type="checkbox"/>	<input type="checkbox"/>	_____

VIN: \_\_\_\_\_ Customer Name: \_\_\_\_\_

W.O.# \_\_\_\_\_ Date: \_\_\_\_\_

This form must be attached to Work Order

PIIB8742E

# AUTOMATIC DRIVE POSITIONER

## AUTOMATIC DRIVE POSITIONER

PFP:28491

### Component Parts And Harness Connector Location

NIS0025Q

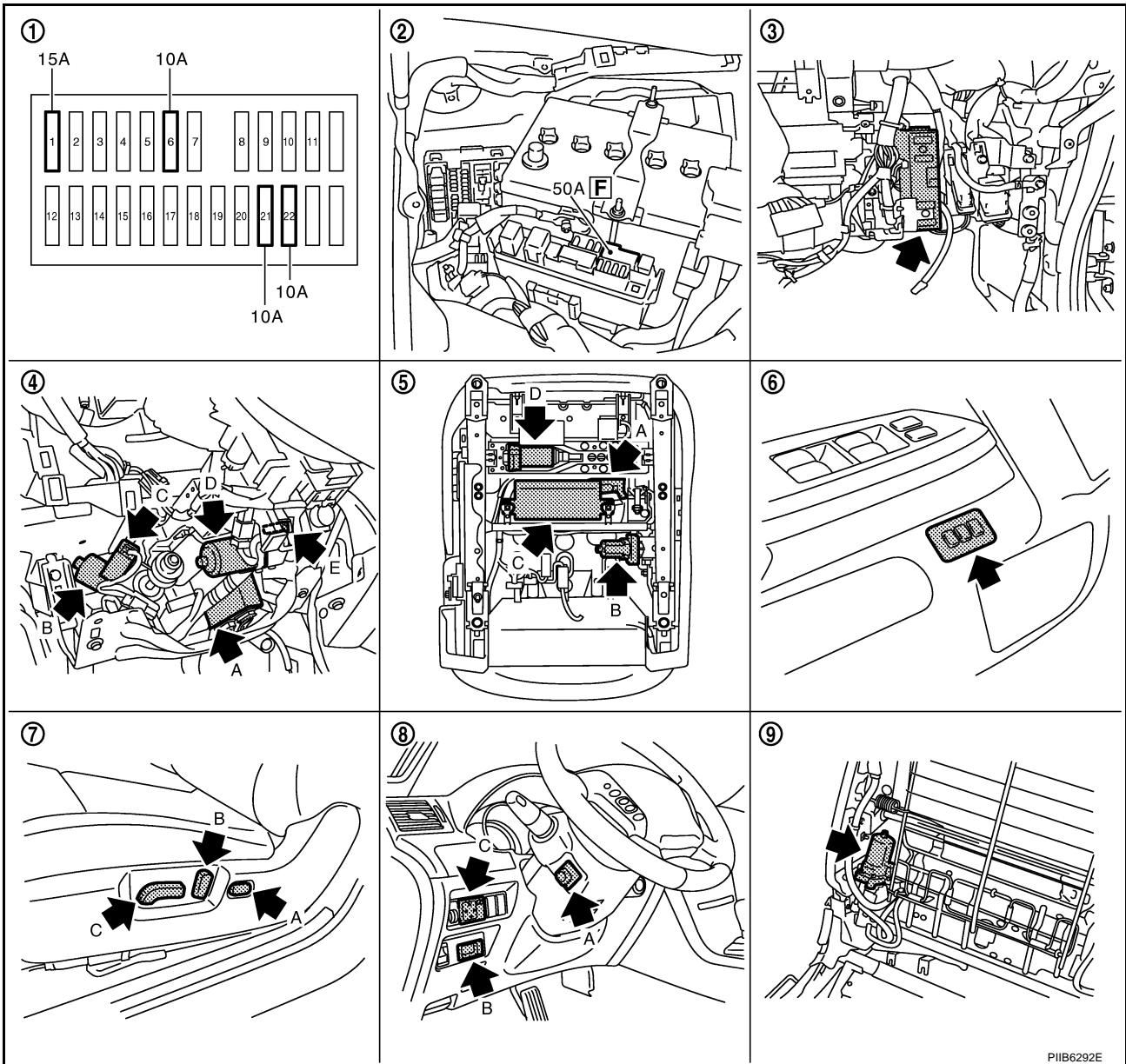

- |                                                                                                                                                                                                                  |                                                                                                                                           |                                                                         |
|------------------------------------------------------------------------------------------------------------------------------------------------------------------------------------------------------------------|-------------------------------------------------------------------------------------------------------------------------------------------|-------------------------------------------------------------------------|
| <p>1. Fuse block (J/B)</p>                                                                                                                                                                                       | <p>2. Fuse and fusible link box</p>                                                                                                       | <p>3. BCM M1, M2, M3<br/>(View with the glove box assembly removed)</p> |
| <p>4. A. Automatic drive positioner control unit M6, M7<br/>B. Telescopic motor M45<br/>C. Telescopic sensor M44<br/>D. Tilt sensor M37<br/>E. Tilt motor M36<br/>(View with the driver lower panel removed)</p> | <p>5. A. Front lifting motor B209<br/>B. Rear lifting motor B210<br/>C. Driver seat control unit B204, B205<br/>D. Sliding motor B207</p> | <p>6. Seat memory switch D9</p>                                         |
| <p>7. A. Lumbar support switch B212<br/>B. Reclining switch B213<br/>C. Sliding/Lifting switch B213</p>                                                                                                          | <p>8. A. ADP steering switch M46<br/>B. Key slot M14<br/>C. Door mirror control switch M95</p>                                            | <p>9. Reclining motor B208</p>                                          |

# AUTOMATIC DRIVE POSITIONER

NIS0025R

## System Description

- The system automatically moves the driver seat, steering and door mirror position by the driver seat control unit and the automatic drive positioner control unit. The driver seat control unit corresponds with the automatic drive positioner control unit via UART communication. The driver seat control unit can store the optimum driving positions (driver seat, steering and door mirror position) for 2 people. If the driver changes, one-touch operation allows changing to the other driving position.
- The driver seat, steering and door mirror position are adjusted automatically to the proper positions for the driver in different ways: MEMORY OPERATION, EXITING OPERATION, ENTRY OPERATION and INTELLIGENT KEY INTERLOCK OPERATION.

Function		Description	
Manual operation		The driving position (seat, steering and door mirror position) can be adjusted with the power seat switch ADP steering switch or door mirror control switch.	
Auto- matic operation	Memory operation	The seat, steering and door mirror move to the stored driving position by pushing seat memory switch (1 or 2).	
	Entry/ Exiting function	Exiting operation	At exit, the seat moves backward and the steering wheel moves upward.
		Entry operation	At entry, the seat and steering wheel returns from exiting position to the previous driving position before the exiting operation.
Intelligent Key interlock operation		Perform memory operation, exiting operation and entry operation by pressing Intelligent Key unlock button.	

## MANUAL OPERATION

The driving position (seat, steering and door mirror position) can be adjusted with the power seat switch, ADP steering switch and door mirror control switch.

### NOTE:

The door mirrors can be manually operated with the ignition switch in either ACC or ON.

## MEMORY OPERATION

The driver seat control unit can store the optimum driving positions (seat, steering and door mirror position) for 2 people. If the front seat position is changed, one-touch (pressing desired memory switch for more than 0.5 second) operation allows changing to the other driving position.

### Operation procedure

1. Turn ignition switch ON.
2. Press desired memory switch for 0.5 second. (Indicator LED illuminates.)
3. Driver seat, steering and door mirror will move to the memorized position. (Indicator LED blinks during adjustment, then illuminates for 5 seconds.)

### Operation Condition

If the following conditions are not satisfied, memory switch operation is not performed.

- Ignition switch is in ON position.
- Driver side power seat switch, ADP steering switch and door mirror control switch are not operated.
- Seat memory switch and set switch are not operated.
- Output malfunction is not detected.
- CAN and UART communications are normal.
- A/T selector lever position is in P position.
- Detention switch malfunction is not detected.  
[Detention switch malfunction is sensed when detention switch remains OFF, vehicle speed is higher than 7 km/H. (4 MPH).]
- Input voltage from tilt sensor and telescopic sensor are normal.

### NOTE:

The memory operation operates following order.

# AUTOMATIC DRIVE POSITIONER

Order of priority	Operated portion
1*	Seat sliding
2	Steering telescopic
3	Steering wheel tilt
4	Seat reclining
5	Seat lifter (front)
6	Seat lifter (rear)

\*: Door mirror operation starts with the start of seat sliding operation.

## Storing Memory Procedure

1. Turn ignition switch to ON.
2. Shift A/T selector lever to P position.
3. Adjust position of driver seat, steering and mirror position.
4. Press set switch.
  - Indicator LED for which driver seat positions are already retained in memory is illuminated for 5 seconds.
  - Indicator LED for which driver seat positions are not retained in memory is illuminated for 0.5 second.
5. Press memory switch for which driver seat positions are to be entered in memory for more than 0.5 second within 5 seconds after pressing the set switch (during the indicator LED is illuminated).
  - To enter driver seat positions in blank memory, indicator LED will be illuminated for 5 seconds.
  - To modify driver seat positions, indicator LED will be turned OFF for 0.5 second then illuminated for 5 seconds.
6.
  - If you need setting of INTELLIGENT KEY INTERLOCK OPERATION, continue this procedure.
  - If you don't need setting of INTELLIGENT KEY INTERLOCK OPERATION, the procedure is finished. Conform the operations of each part with the MEMORY OPERATION.
7. Press intelligent key unlock button within 5 seconds after pressing memory switch. (While memory switch LED is illuminated.)
8. Conform the operations of each part with MEMORY OPERATION and INTELLIGENT KEY INTERLOCK OPERATION.

### NOTE:

- Driving position is erased from the memory when battery cable is disconnected.

A  
B  
C  
D  
E  
F  
G  
H  
SE  
J  
K  
L  
M

# AUTOMATIC DRIVE POSITIONER

---

## EXITING OPERATION

When exiting, when the condition is satisfied, the seat is moved backward 40 mm (1.57 in) from normal sitting position and the steering is moved to the most upper position and front position.

The seat slide amount and the steering operation at entry/exit operation can be changed by set switch, CONSULT-II and display (located in the instrument panel). Refer to [SE-16, "SETTING CHANGE FUNCTION"](#) .

### Operation Condition

- Ignition switch: OFF / Driver side door switch: ON (OPEN)

If the following conditions are not satisfied, exiting operation is not performed.

- Ignition switch is in OFF position.
- A/T selector lever position is in P position.
- Vehicle speed is less than 7 km/h. (4 MPH).
- Driver side power seat switch and ADP steering switch are not operated.
- Seat memory switch and set switch is not operated.
- Door mirror control switch is not operated at change over switch is in LH or RH position.
- Output malfunction is not detected.
- Detention switch malfunction is not detected.  
[Detention switch malfunction is sensed when detention switch remains OFF and vehicle speed is higher than 7 km/h. (4 MPH).]
- CAN communications are normal.
- Initialization has been done. Refer to [SE-16, "INITIALIZATION PROCEDURE"](#) .

## ENTRY OPERATION

When the seat is in the exiting position when either condition (1 or 2) is satisfied, the seat returns from exiting position to the previous driving position.

### Operation Condition

1. Ignition switch: ON
2. Ignition switch: ACC / Driver side door switch: OFF (CLOSE)

If the following conditions are not satisfied, entry operation is not performed.

- Ignition switch is in OFF position.
- A/T selector lever position is in P position.
- Vehicle speed is less than 7 km/h (4 MPH).
- Driver side power seat switch, ADP steering switch and door mirror control switch are not operated.
- Seat memory switch and set switch is not operated.
- Output malfunction is not detected.
- Detention switch malfunction is not detected.  
[Detention switch malfunction is sensed when detention switch remains OFF and vehicle speed is higher than 7 km/h (4 MPH).]
- CAN communications are normal.
- Exiting positions have not been changed during and after exiting operation.

# AUTOMATIC DRIVE POSITIONER

## INTELLIGENT KEY INTERLOCK OPERATION

When pressing unlock button on Intelligent Key or request switch, the system performs memory operation, exiting operation and entry operation.

### Operation procedure

1. Press unlock button on Intelligent Key or request switch.
2. The system performs MEMORY OPERATION, and then performs EXITING OPERATION continually.

### NOTE:

If the seat position is in memorized position before push unlock button, MEMORY OPEPATION dose not perform.

3. Turn ignition switch ON or close driver side door when ignition switch is in "ACC" position.
4. The system performs ENTRY OPERATION. (Seat and steering positions are moved to memorized positions. The memorize position is related to key ID.)

### Operation Condition

If the following conditions are not satisfied, memory switch operation is not performed.

- Ignition switch is in OFF position.
- Driver side power seat switch and door mirror control switch are not operated.
- Seat memory switch and set switch are not operated.
- Output malfunction is not detected.
- CAN and UART communications are normal.
- A/T selector lever position is in P position.
- Detention position switch malfunction is not detected.  
[Detention position switch malfunction is sensed when detention switch remains OFF and vehicle speed is higher than 7 km/h (4 MPH).]

### Linking Intelligent Key to the Stored Memory Procedure

#### NOTE:

- If ignition switch turns ON in the middle of memory operation, the system does not perform exiting operation after memory operation.
- If ignition switch turns ON in the middle of exiting operation, entry operation starts at that time.
- If entry / exiting operation is cancelled, perform memory operation only.

### FAIL-SAFE MODE

If any of the parts move more than a period "T" without any switch operation, MEMORY OPERATION, EXITING OPERATION, ENTRY OPERATION, INTELLIGENT KEY INTERLOCK OPERATION and the malfunction part of manual operations are not operated (output malfunction).

Operated portion	T
Seat sliding	Approx. 0.1 sec.
Seat reclining	Approx. 0.1 sec.
Seat lifter (front)	Approx. 0.1 sec.
Seat lifter (rear)	Approx. 0.1 sec.
Steering tilt	Approx. 0.1 sec.

### Canceling Fail-safe Mode

The mode is cancelled by either of the following operations.

- When the selector lever is shifted to P position from any other position (detention switch is turned OFF).

# AUTOMATIC DRIVE POSITIONER

## INITIALIZATION PROCEDURE

After reconnecting battery cable, perform initialization procedure A or B. If initialization has not been performed, EXITING OPERATION will not operate.

### Procedure A

1. Turn ignition switch from ACC to OFF position.
2. Driver door switch is ON (open) → OFF (close) → ON (open).
3. END

### Procedure B

1. Drive the vehicle at more than 25 km/h (16 MPH).
2. END

## SETTING CHANGE FUNCTION

The settings of the automatic driving positioner system can be changed, using CONSULT-II and the display unit in the center of the instrument panel.

×: Applicable –: Not applicable

Setting item	Content	CONSULT-II (WORK SUPPORT)	Display unit	Factory setting
Change seat sliding volume setting	The distance at retain operation can be selected from the following 3 modes.	40 mm	—	×
		80 mm		—
		150 mm		—
Change the Entry/Exit seat slide function setting	The seat sliding turnout and return at entry/exit can be selected: ON (operated) – OFF (not operated)	ON	ON: Indicator lamp ON	×
		OFF	OFF: Indicator lamp OFF	—
Change the Entry/Exit tilt steering wheel function setting	Lift up and backward steering wheel at entry and exit can be selected: ON (operated) - OFF (not operated)	ON	ON: Indicator lamp ON	×
		OFF	OFF: Indicator lamp OFF	—
Reset custom settings	All settings to default.	—	Default: Setting button OFF	—

It is possible to set sliding driver seat for entry/exit of vehicle by pressing set switch.

Content	Setting change operation	Indicator LED
The seat sliding turnout and steering wheel up/backward at entry/exit can be operated.	Press the set switch for more than 10 seconds	Blinking twice
The seat sliding turnout and steering wheel up/backward at entry/exit can be not operated.		Blinking ones

## CAN Communication System Description

*NIS0025S*

CAN (Controller Area Network) is a serial communication line for real time application. It is an on-vehicle multiplex communication line with high data communication speed and excellent error detection ability. Many electronic control units are equipped onto a vehicle, and each control unit shares information and links with other control units during operation (not independent). In CAN communication, control units are connected with 2 communication lines (CAN H line, CAN L line) allowing a high rate of information transmission with less wiring. Each control unit transmits/receives data but selectively reads required data only.

## CAN Communication Unit

*NIS0025T*

Refer to [LAN-50, "CAN System Specification Chart"](#) .



# AUTOMATIC DRIVE POSITIONER

## Schematic

NIS0025U

A  
B  
C  
D  
E  
F  
G  
H  
SE  
J  
K  
L  
M

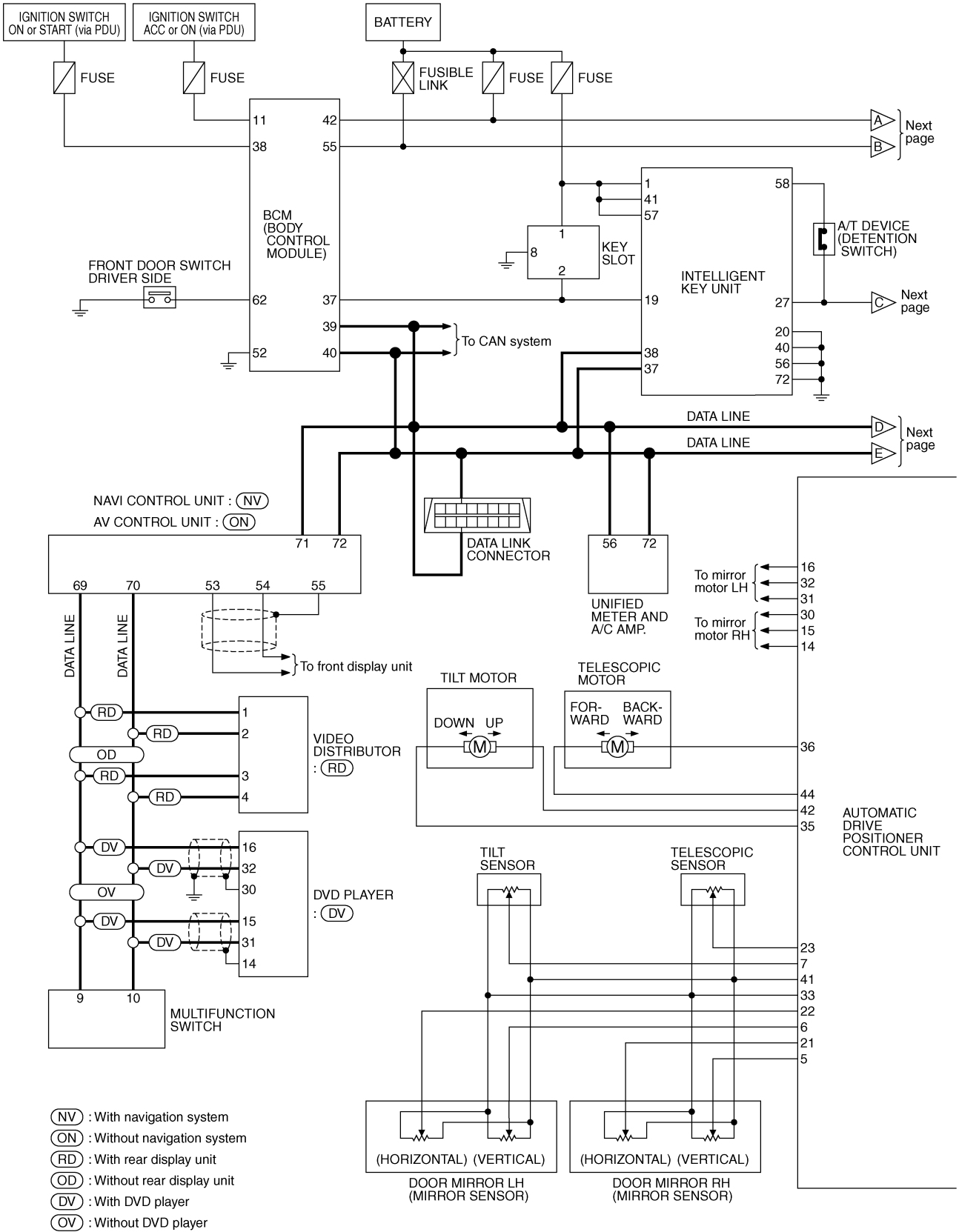

- (NV) : With navigation system
- (ON) : Without navigation system
- (RD) : With rear display unit
- (OD) : Without rear display unit
- (DV) : With DVD player
- (OV) : Without DVD player

TIWT1371E

# AUTOMATIC DRIVE POSITIONER

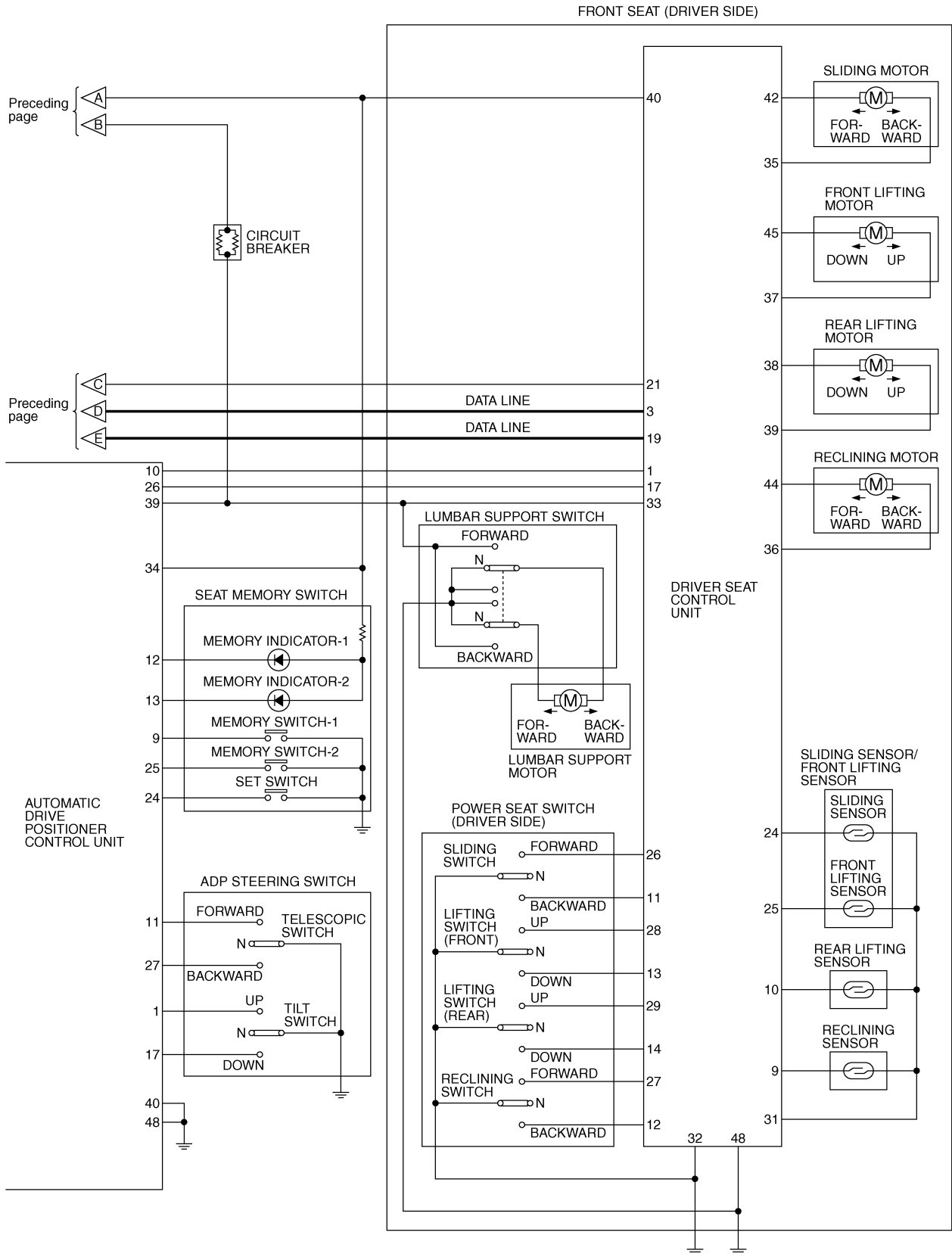

TIWT2133E

# AUTOMATIC DRIVE POSITIONER

## Wiring Diagram — AUT/DP —

NIS0025V

**SE-AUT/DP-01**

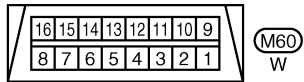
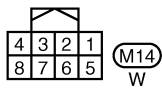
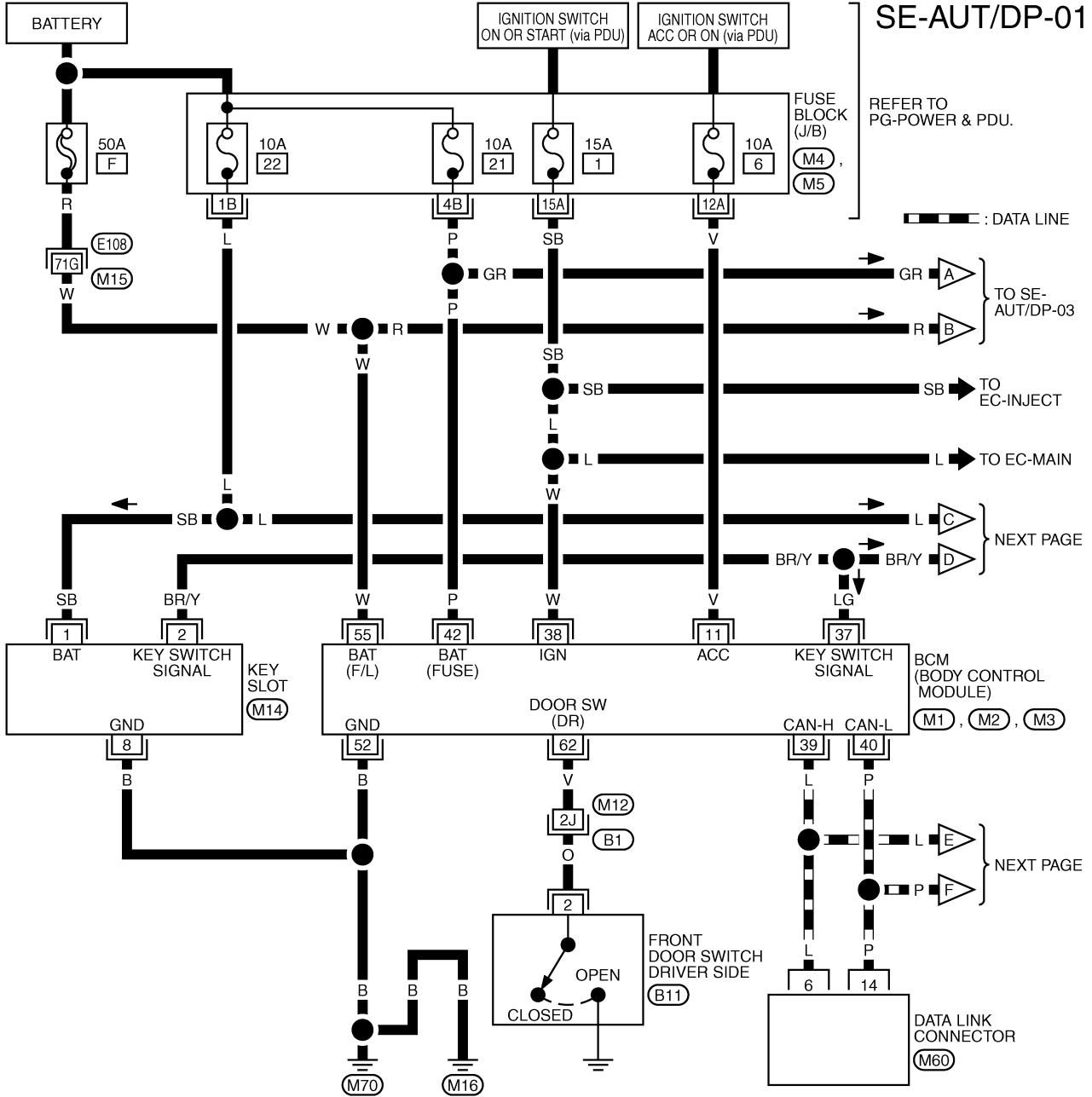

REFER TO THE FOLLOWING.  
 (E108), (B1) -SUPER MULTIPLE JUNCTION (SMJ)  
 (M4), (M5) -FUSE BLOCK-JUNCTION BOX (J/B)  
 (M1), (M2), (M3) -ELECTRICAL UNITS

A  
B  
C  
D  
E  
F  
G  
H  
SE  
J  
K  
L  
M

TIWT2127E

# AUTOMATIC DRIVE POSITIONER

SE-AUT/DP-02

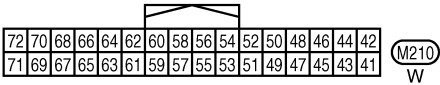
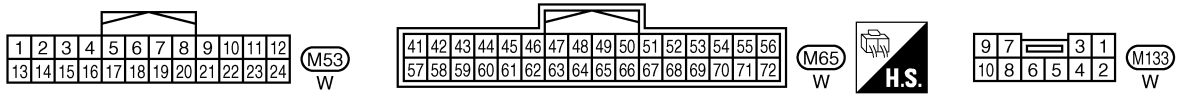
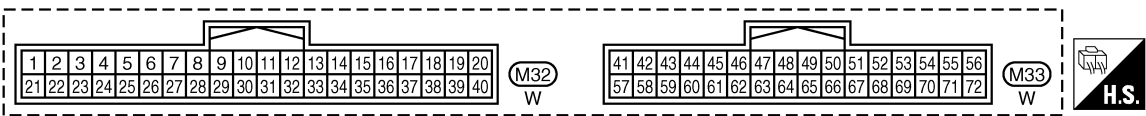
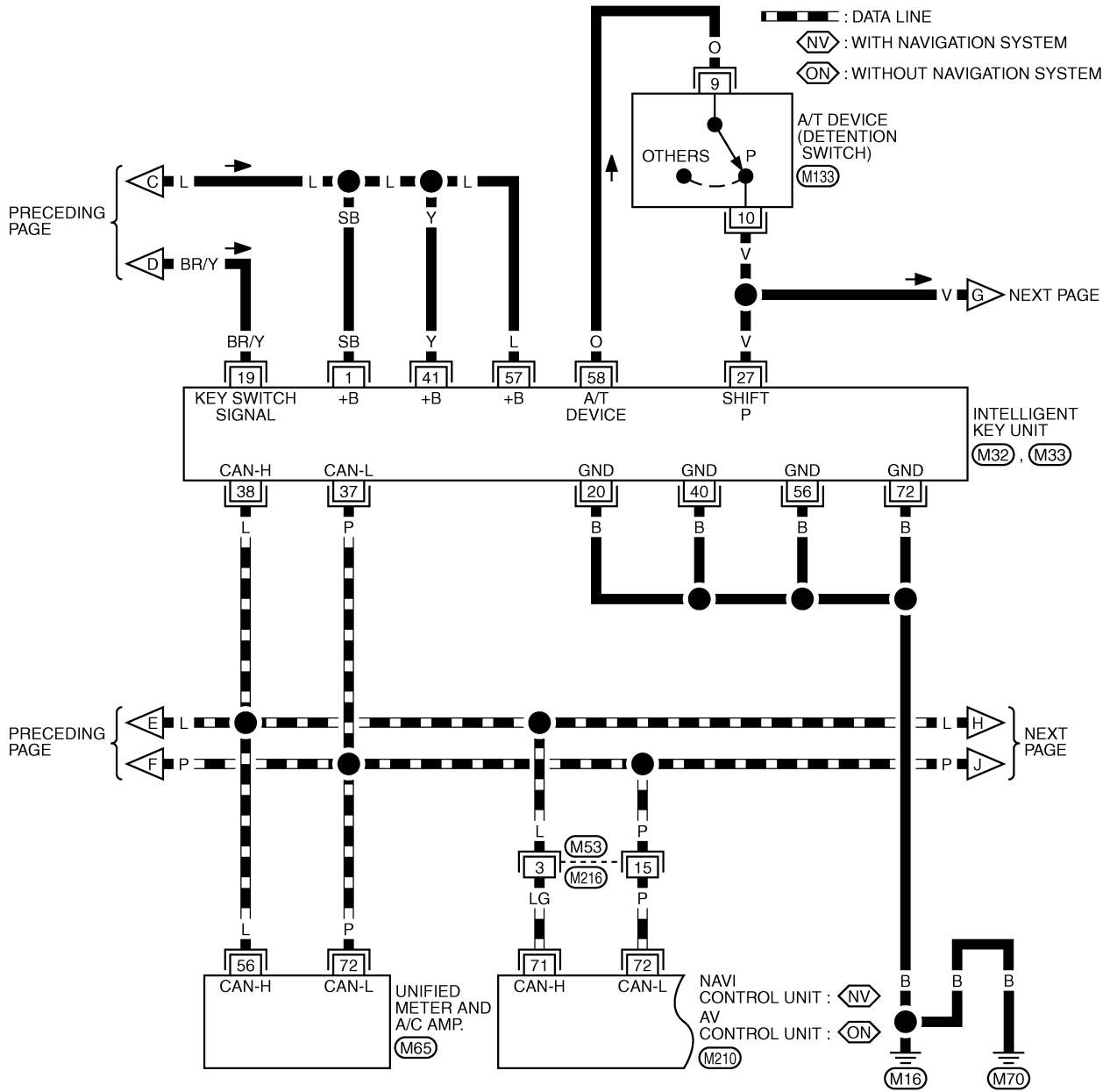

TIWT1374E

# AUTOMATIC DRIVE POSITIONER

SE-AUT/DP-03

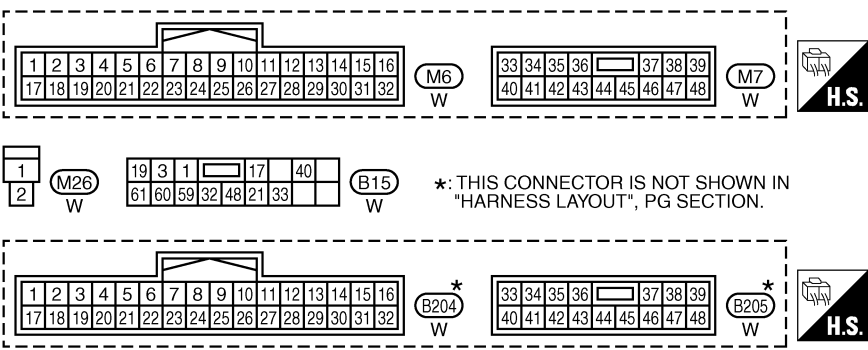
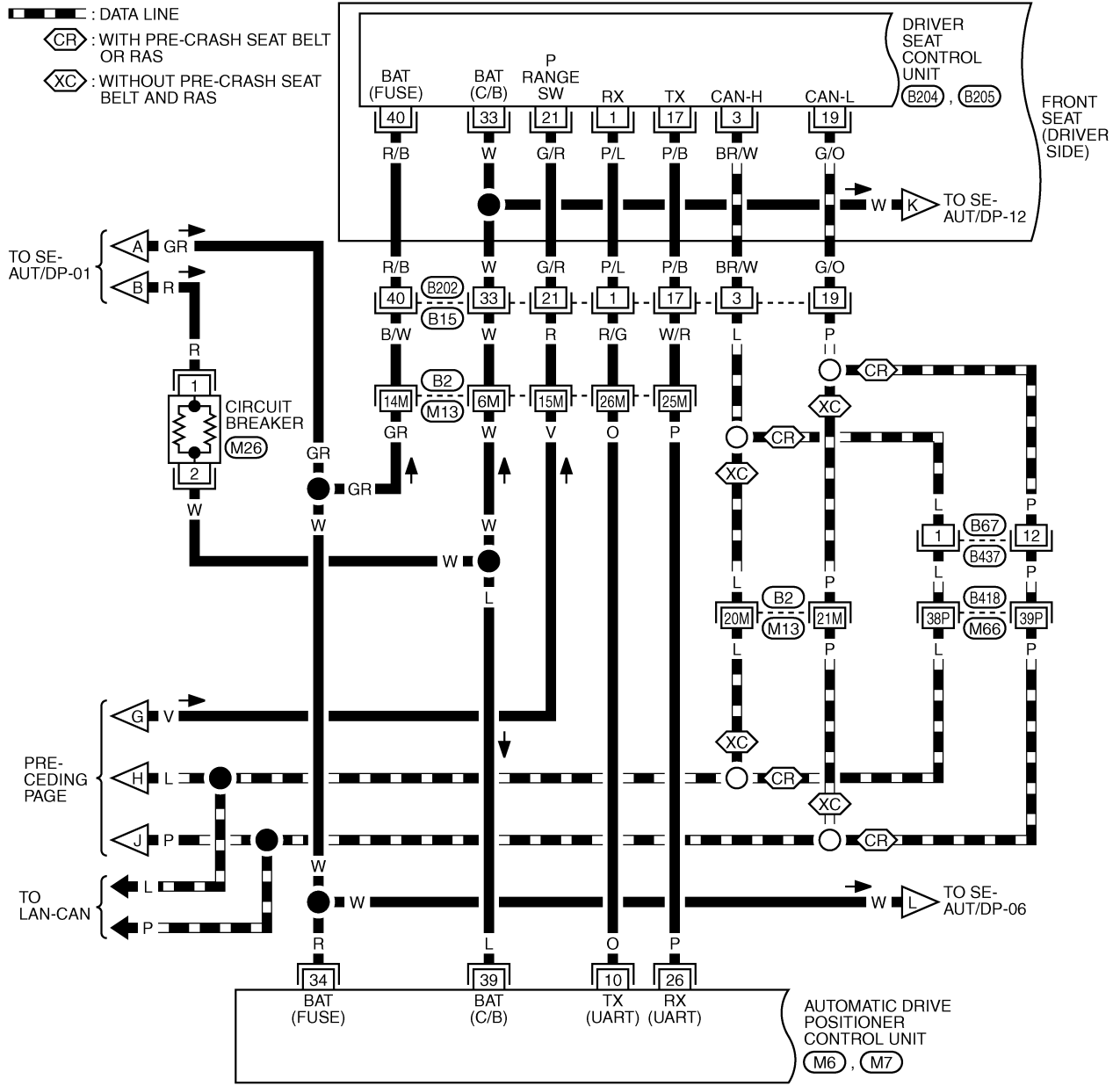

REFER TO THE FOLLOWING.  
 (B2), (B418) -SUPER MULTIPLE JUNCTION (SMJ)

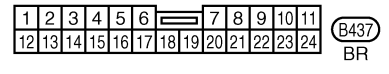

TIWT2045E



# AUTOMATIC DRIVE POSITIONER

SE-AUT/DP-05

▬ : DATA LINE

- ⬡ : WITH DVD PLAYER
  - ⬡ : WITHOUT DVD PLAYER
  - ⬡ : WITH BOSE SYSTEM
  - ⬡ : WITHOUT BOSE SYSTEM
  - ⬡ : 2WD MODELS WITHOUT BOSE SYSTEM, NAVIGATION SYSTEM AND RAS
  - ⬡ : WITHOUT DVD PLAYER EXCEPT ⬡
- \*1 LG : ⬡ \*3 P : ⬡
  - Y : ⬡ R : ⬡
  - \*2 V : ⬡ O : ⬡
  - R : ⬡ \*4 L : ⬡
  - O : ⬡ Y : ⬡
  - \*5 R : ⬡
  - O : ⬡

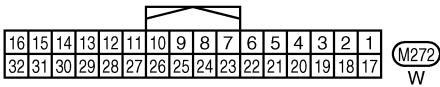
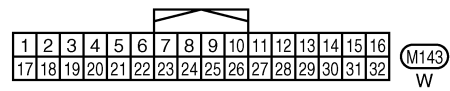
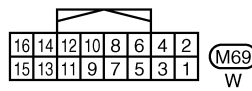
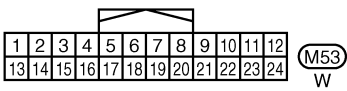
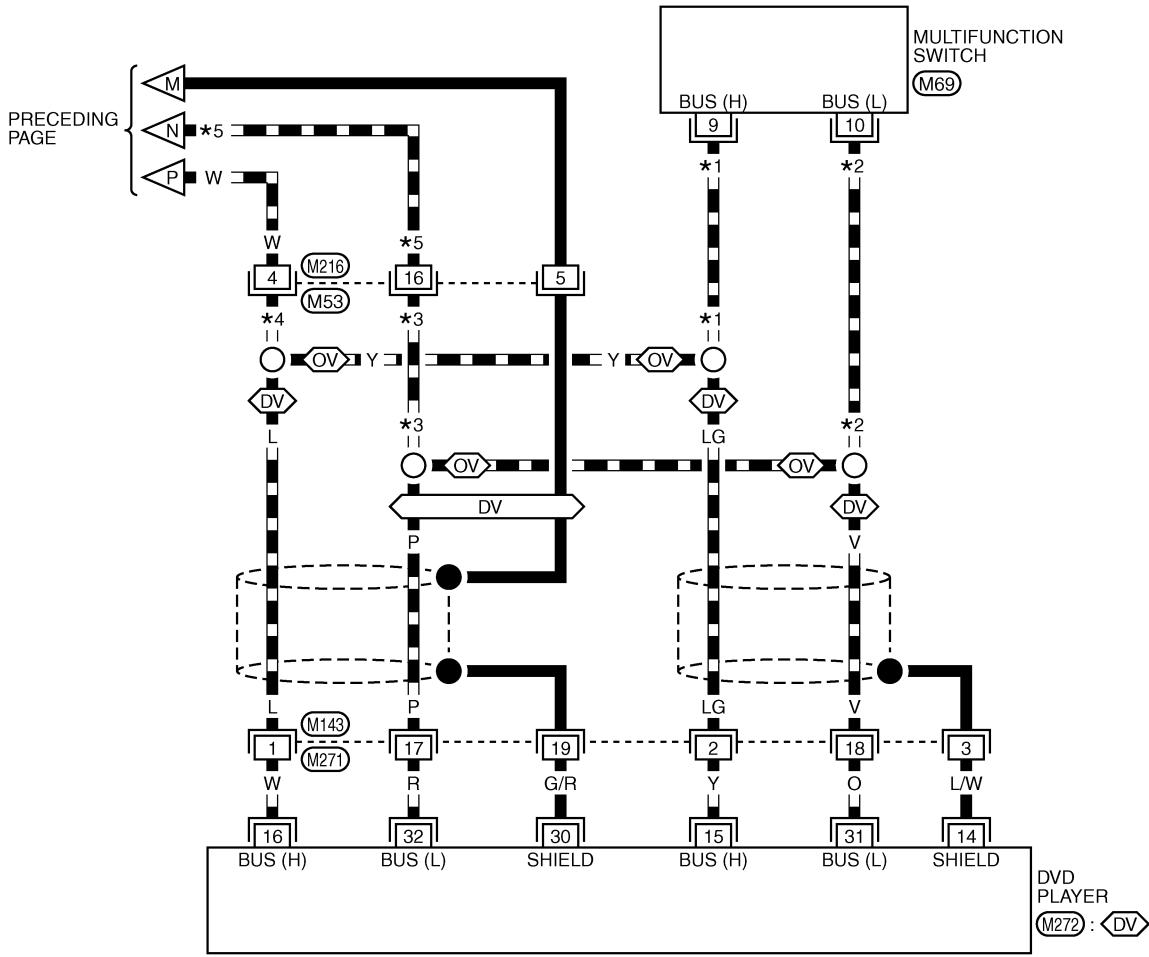

TIWT2047E

# AUTOMATIC DRIVE POSITIONER

SE-AUT/DP-06

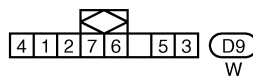
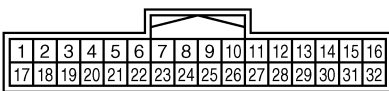
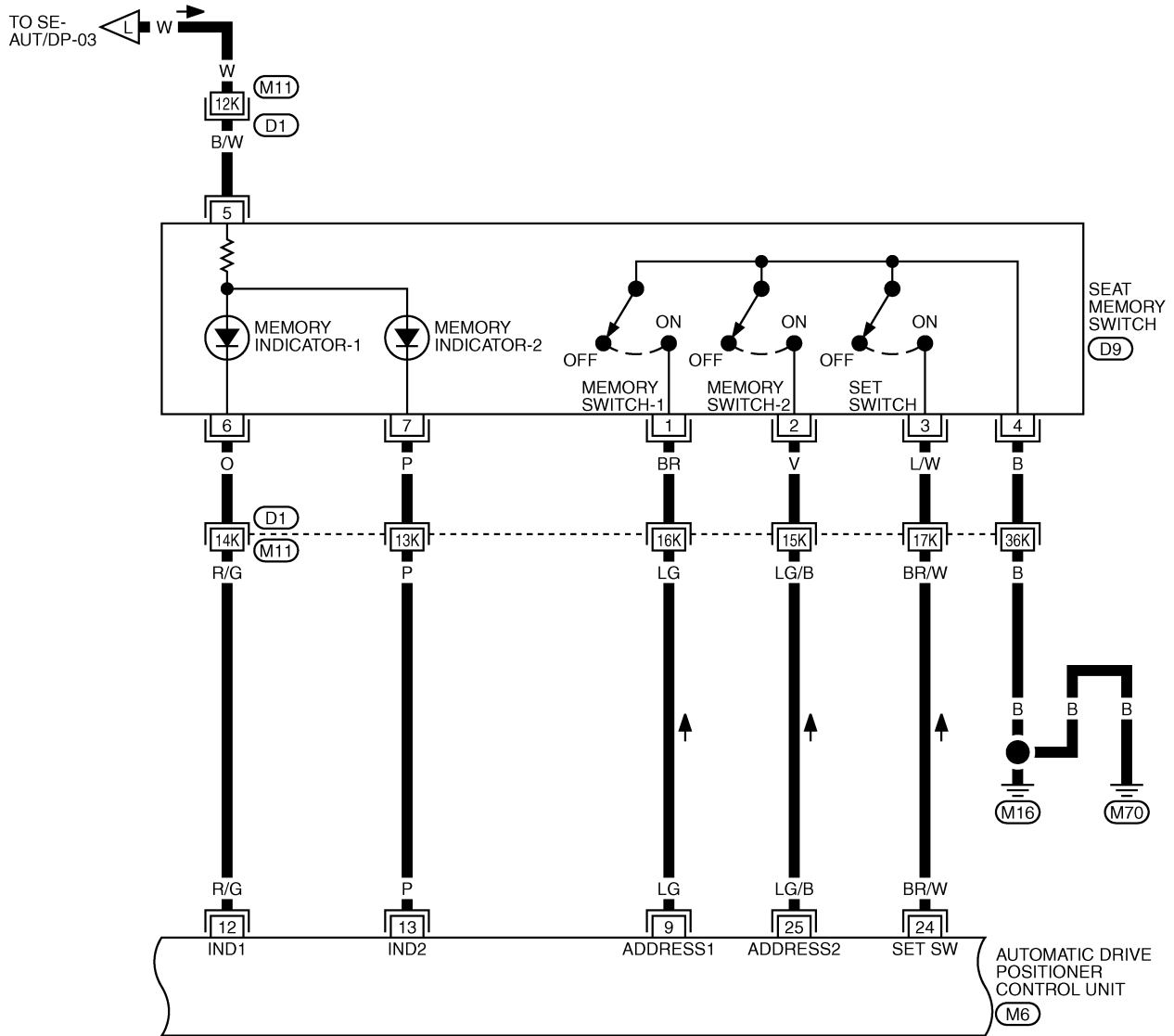

REFER TO THE FOLLOWING.

(D1) -SUPER MULTIPLE JUNCTION (SMJ)

TIWT2048E



# AUTOMATIC DRIVE POSITIONER

SE-AUT/DP-07

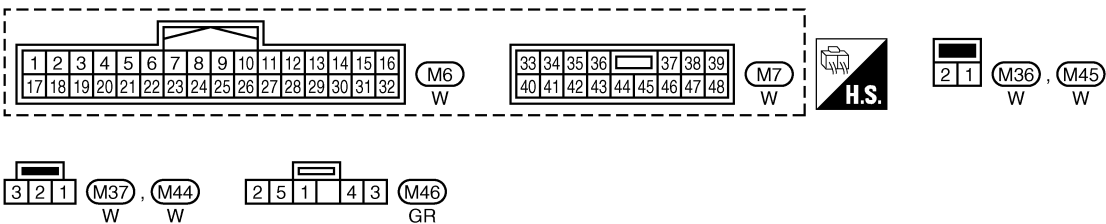
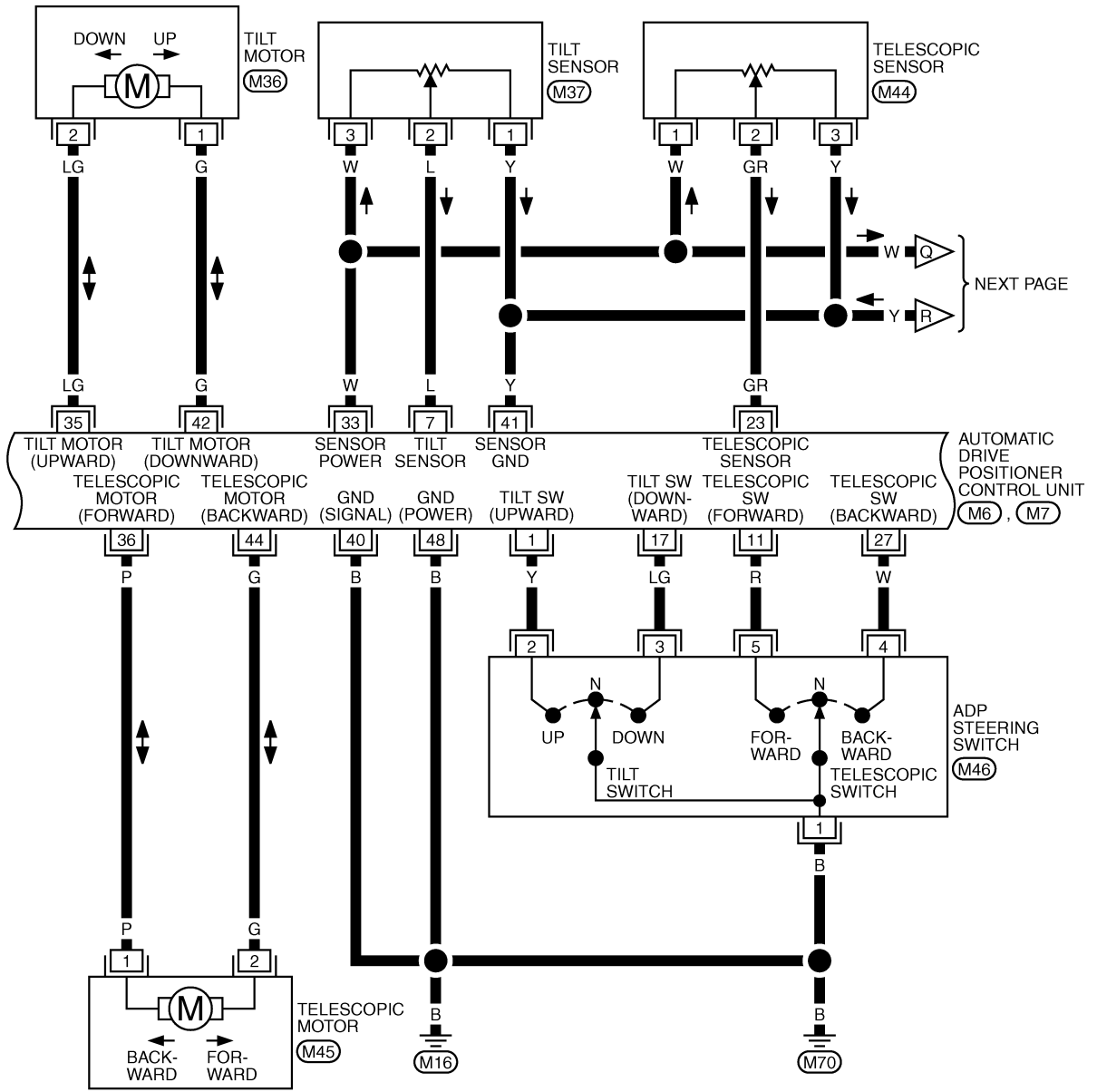

TIWT2049E

# AUTOMATIC DRIVE POSITIONER

SE-AUT/DP-08

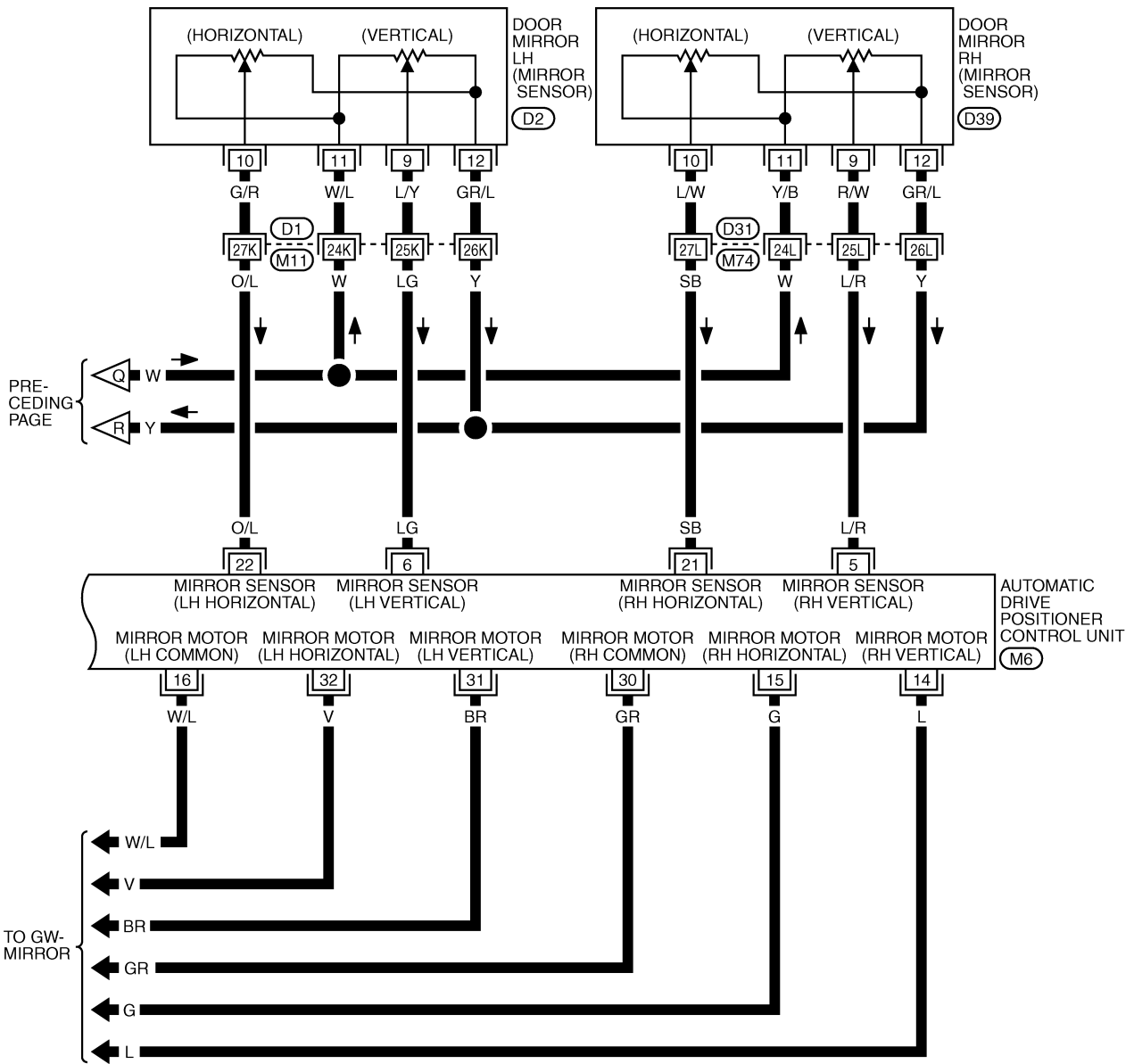

1	2	3	4	5	6	7	8	9	10	11	12	13	14	15	16
17	18	19	20	21	22	23	24	25	26	27	28	29	30	31	32

M6  
W



4	1	2	7	6	5
8	3	9	10	11	12

D2, D39  
W W

REFER TO THE FOLLOWING.  
D1, D31 -SUPER MULTIPLE JUNCTION (SMJ)

TIWT2050E

# AUTOMATIC DRIVE POSITIONER

SE-AUT/DP-09

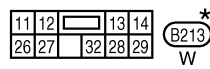
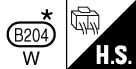
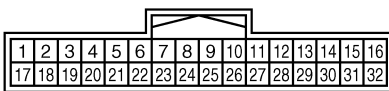
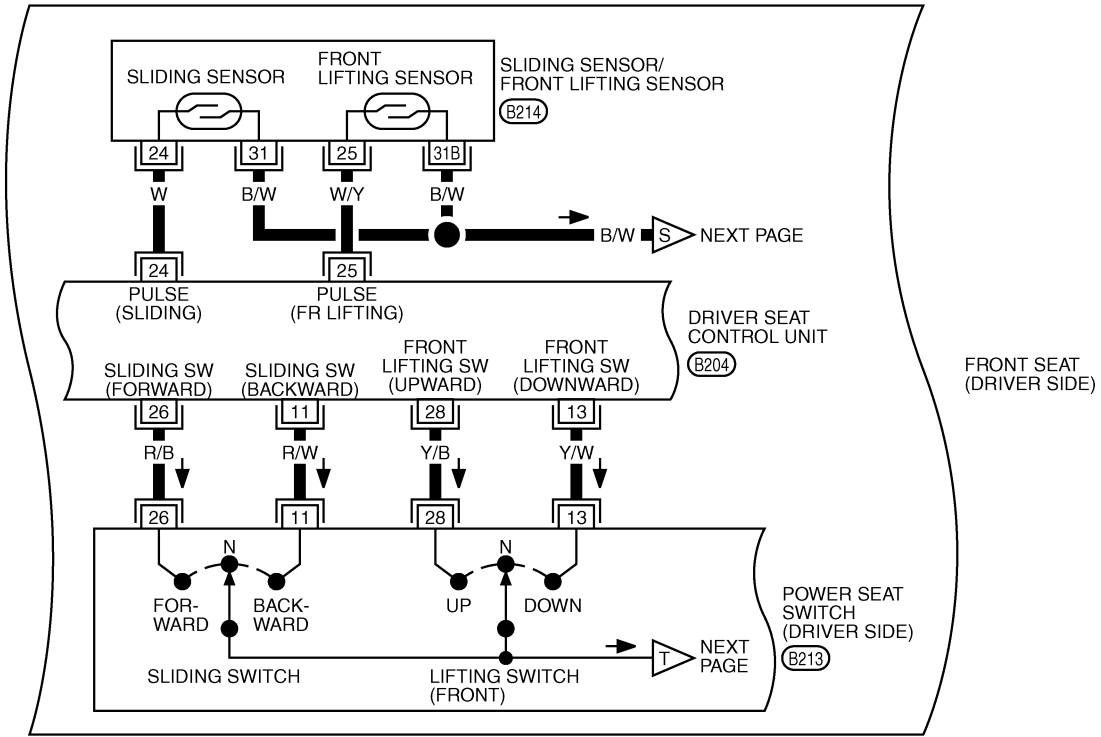

\*: THIS CONNECTOR IS NOT SHOWN IN "HARNESS LAYOUT", PG SECTION.

TIWT2051E

# AUTOMATIC DRIVE POSITIONER

SE-AUT/DP-10

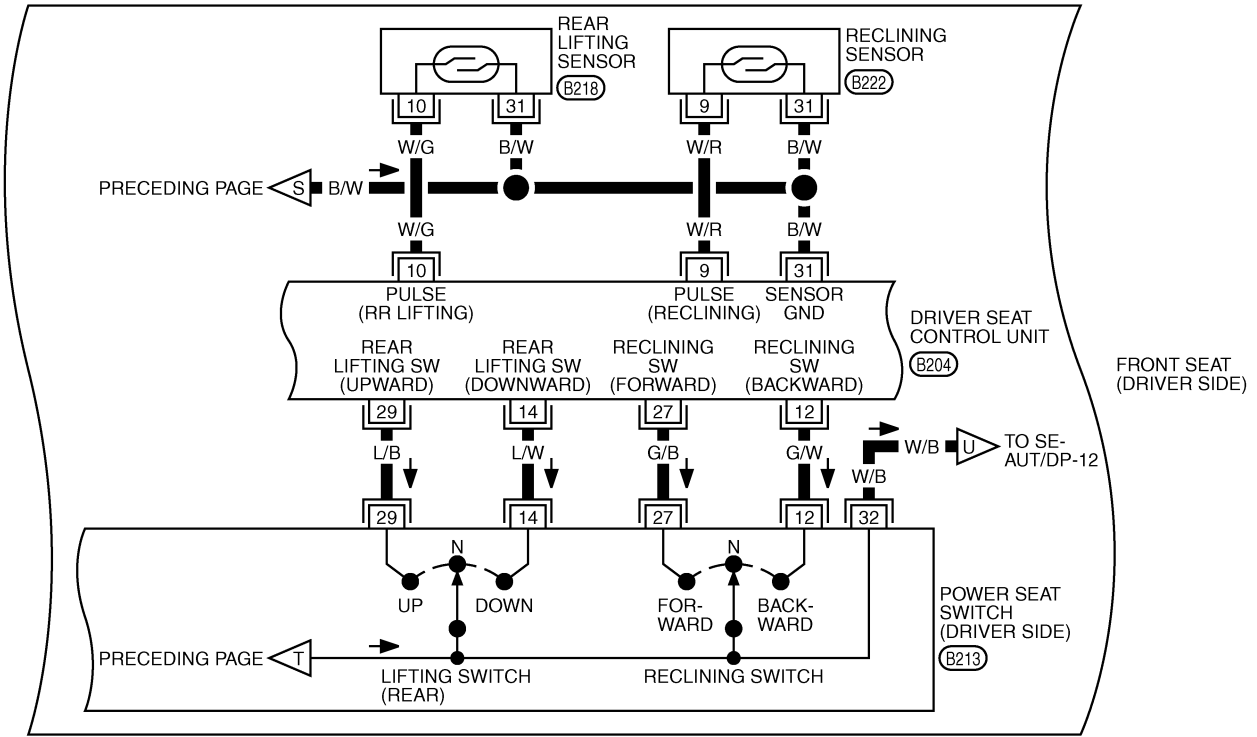

1	2	3	4	5	6	7	8	9	10	11	12	13	14	15	16
17	18	19	20	21	22	23	24	25	26	27	28	29	30	31	32

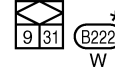
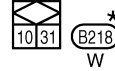
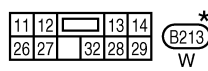

\*: THIS CONNECTOR IS NOT SHOWN IN "HARNESS LAYOUT", PG SECTION.

TIWT2052E

# AUTOMATIC DRIVE POSITIONER

SE-AUT/DP-11

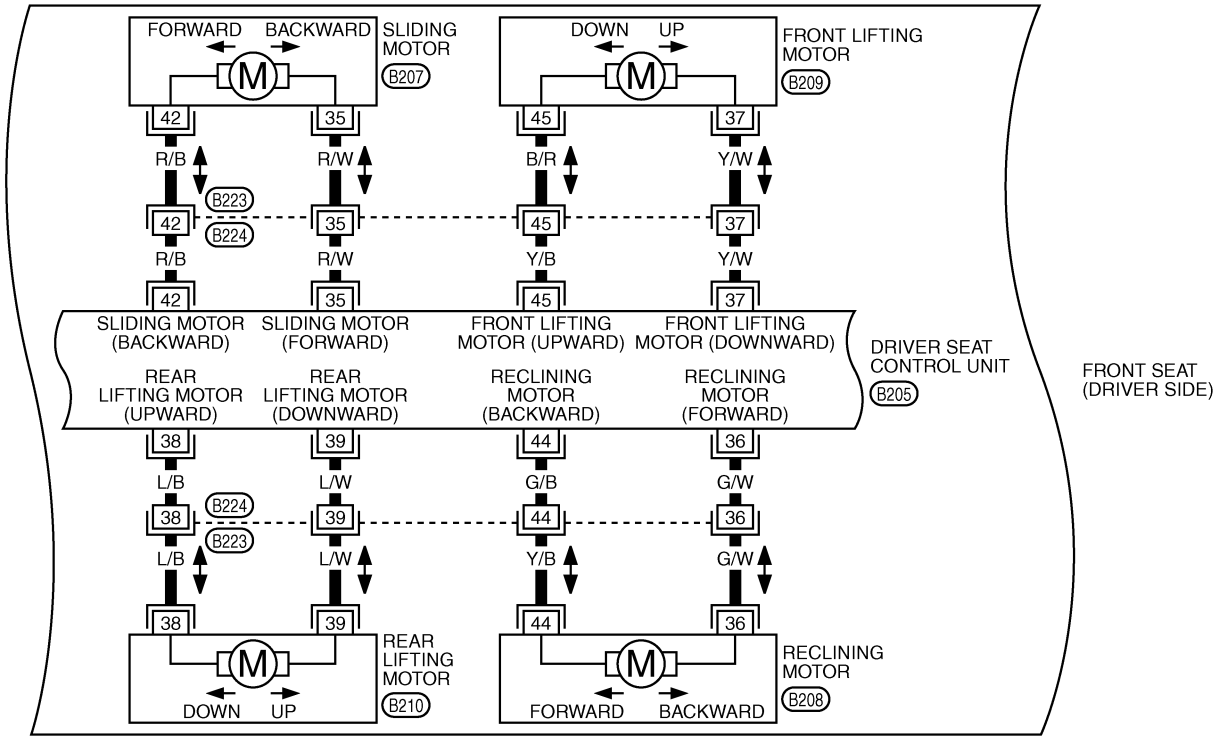

33	34	35	36	37	38	39		
40	41	42	43	44	45	46	47	48

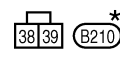
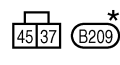
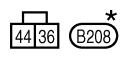
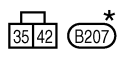

56	55	58	57	39		
38	37	45	44	36	42	35

B223\*  
GR

\*: THIS CONNECTOR IS NOT SHOWN IN "HARNESS LAYOUT", PG SECTION.

# AUTOMATIC DRIVE POSITIONER

SE-AUT/DP-12

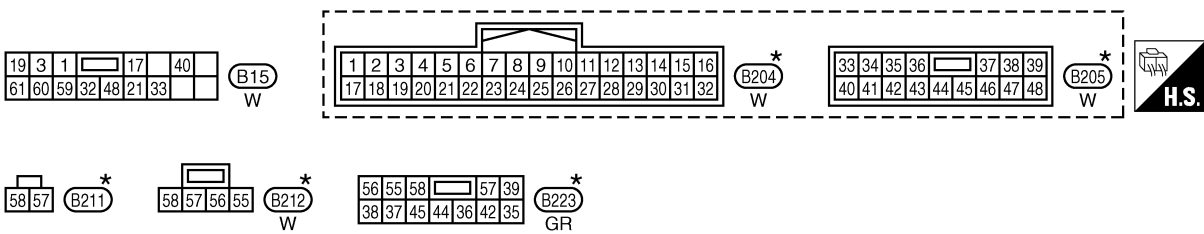
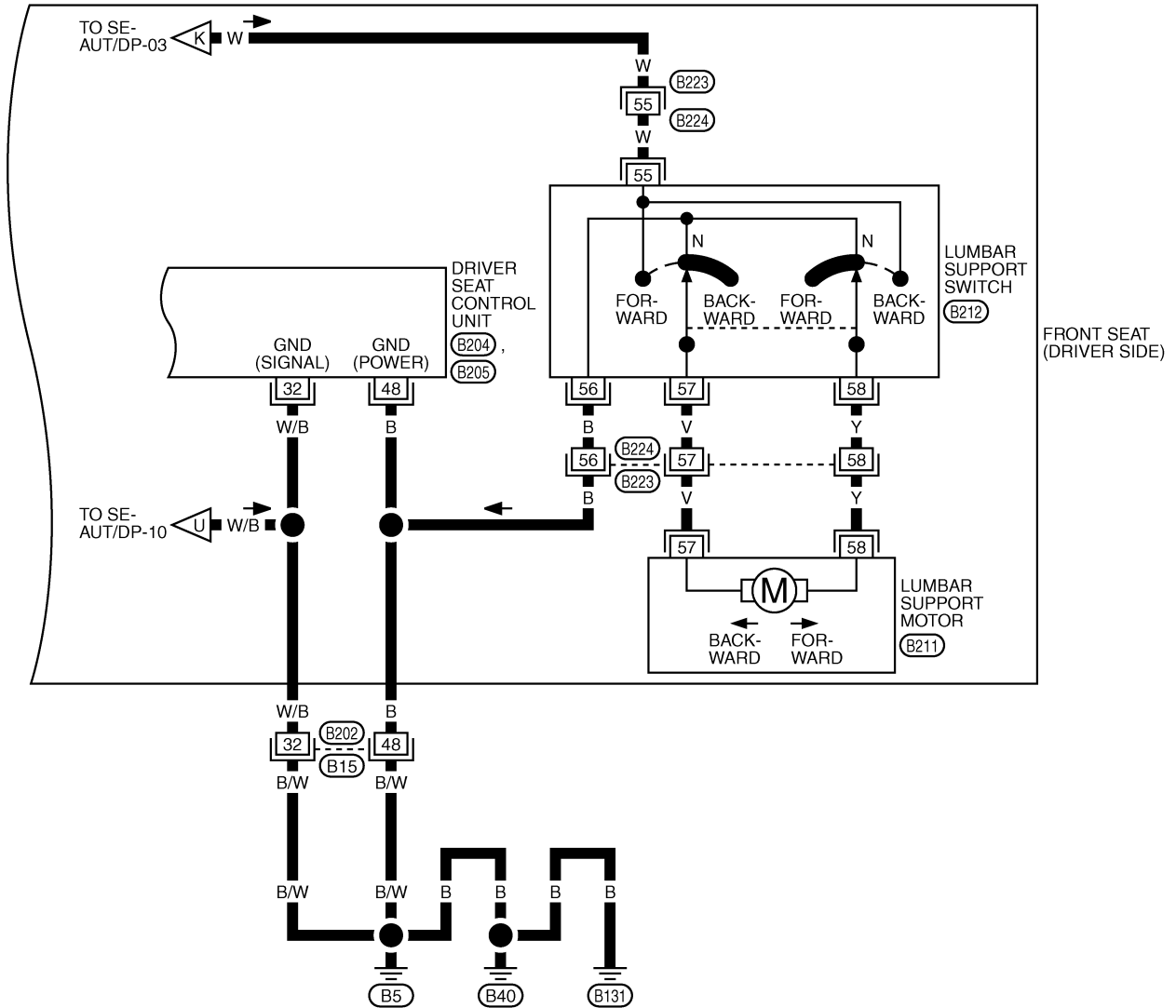

\*: THIS CONNECTOR IS NOT SHOWN IN "HARNESS LAYOUT", PG SECTION.

TIWT2054E

# AUTOMATIC DRIVE POSITIONER

## Terminals and Reference Values for BCM

NIS0025W

Terminal	Wire color	Item	Signal Input/Output	Condition	Voltage (V) (Approx)
11	V	Power source (ACC)	Input	Ignition switch (ACC or ON position)	Battery voltage
37	LG	Key switch signal	Input	Key switch ON (Key is inserted in key slot)	Battery voltage
				Key switch OFF (Key is remove from key slot)	0
38	W	Power source (IGN)	Input	Ignition switch (ON or START position)	Battery voltage
39	L	CAN-H	Input/Output	—	—
40	P	CAN-L	Input/Output	—	—
42	P	Power source (Fuse)	Input	—	Battery voltage
52	B	Ground	—	—	0
55	W	Power source (Fusible link)	Input	—	Battery voltage
62	V	Drive side door switch	Input	ON (Open) → OFF (Closed)	0 → Battery voltage

## Terminals and Reference Value for Intelligent Key Unit

NIS0025X

Terminal	Wire Color	Item	Signal Input/Output	Condition		Voltage (V) Approx.
				Ignition Switch Position	Operation or Conditions	
1	SB	Power source (Fuse)	Input	—	—	Battery voltage
19	BR/Y	Key switch signal	Input	LOCK	Insert Intelligent Key into key slot.	Battery voltage
					Remove Intelligent Key from key slot.	0
20	B	Ground	—	ON	—	0
27	V	P range switch	Input	—	Selector lever is in "P" position.	0
					Other than above	Battery voltage
37	P	CAN-L	Input/Output	—	—	—
38	L	CAN-H	Input/Output	—	—	—
40	B	Ground	—	ON	—	0
41	Y	Power source (Fuse)	Input	—	—	Battery voltage
56	B	Ground	—	—	—	0
57	L	Power source (Fuse)	Input	—	—	Battery voltage
58	O	A/T device power supply	Output	—	Wake up state	Battery voltage
					Sleep state	0
72	B	Ground	—	ON	—	0

# AUTOMATIC DRIVE POSITIONER

## Terminals and Reference Values for Driver Seat Control Unit

NIS0025Y

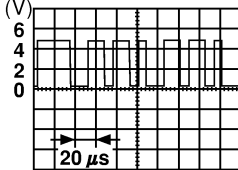
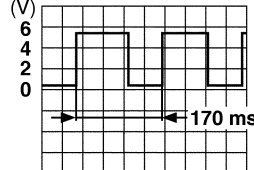
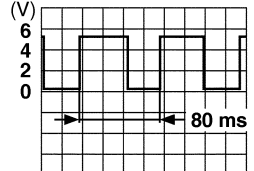
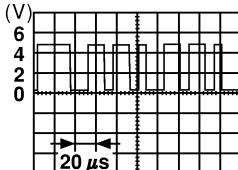
Terminal	Wire color	Item	Signal Input/Output	Condition	Voltage (V) (Approx)
1	P/L	UART LINE (RX)	Input	Tilt switch operated	 <p style="text-align: right; font-size: small;">SKIA0175E</p>
3	BR/W	CAN-H	Input/Output	—	—
9	W/R	Reclining sensor signal	Input	ON (seat reclining motor operation)	 <p style="text-align: right; font-size: small;">PIIB2807E</p>
				Other than above	0 or 5
10	W/G	Rear lifting sensor signal	Input	ON (rear lifting motor operation)	 <p style="text-align: right; font-size: small;">PIIB2809E</p>
				Other than above	0 or 5
11	R/W	Sliding switch backward signal	Input	ON (seat sliding switch backward operation)	0
				Other than above	Battery voltage
12	G/W	Reclining switch backward signal	Input	ON (seat reclining switch backward operation)	0
				Other than above	Battery voltage
13	Y/W	Front lifting switch DOWN signal	Input	ON (front lifting switch DOWN operation)	0
				Other than above	Battery voltage
14	L/W	Rear lifting switch DOWN signal	Input	ON (rear lifting switch DOWN operation)	0
				Other than above	Battery voltage
17	P/B	UART LINE (TX)	Output	Tilt switch operated	 <p style="text-align: right; font-size: small;">SKIA0175E</p>
19	G/O	CAN-L	Input/Output	—	—
21	G/R	Detention switch signal	Input	A/T selector lever is in P position.	0
				A/T selector lever is in other than P position.	Battery voltage

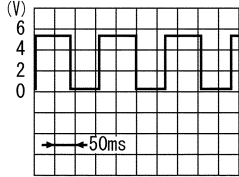
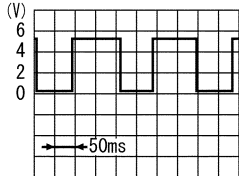

# AUTOMATIC DRIVE POSITIONER

Terminal	Wire color	Item	Signal Input/Output	Condition	Voltage (V) (Approx)
24	W	Seat sliding sensor signal	Input	ON (seat sliding motor operation)	 <p style="text-align: right; font-size: small;">SIIA0690J</p>
				Other than above	0 or 5
25	W/Y	Front lifting sensor signal	Input	ON (front lifting motor operation)	 <p style="text-align: right; font-size: small;">SIIA0691J</p>
				Other than above	0 or 5
26	R/B	Seat sliding switch forward signal	Input	ON (seat sliding switch forward operation)	0
				Other than above	Battery voltage
27	G/B	Seat reclining switch forward signal	Input	ON (seat reclining switch forward operation)	0
				Other than above	Battery voltage
28	Y/B	Front lifting switch UP signal	Input	ON (front lifting switch UP operation)	0
				Other than above	Battery voltage
29	L/B	Rear lifting switch UP signal	Input	ON (rear lifting switch UP operation)	0
				Other than above	Battery voltage
31	B/W	Sensor ground	—	—	0
32	W/B	Ground (signal)	—	—	0
33	W	Power source (C/B)	Input	—	Battery voltage
35	R/W	Sliding motor forward signal	Output	Sliding switch forward operation (Motor operated)	Battery voltage
				Other than above	0
36	G/W	Reclining motor forward signal	Output	Reclining switch forward operation (Motor operated)	Battery voltage
				Other than above	0
37	Y/W	Front lifting motor DOWN signal	Output	Front lifting switch down operation (Motor operated)	Battery voltage
				Other than above	0
38	L/B	Rear lifting motor UP signal	Output	Rear lifting switch up operation (Motor operated)	Battery voltage
				Other than above	0
39	L/W	Rear lifting motor DOWN signal	Output	Rear lifting switch down operation (Motor operated)	Battery voltage
				Other than above	0
40	R/B	Power source (Fuse)	Input	—	Battery voltage
42	R/B	Sliding motor backward signal	Output	Sliding switch backward operation (Motor operated)	Battery voltage
				Other than above	0

A  
B  
C  
D  
E  
F  
G  
H  
J  
K  
L  
M

SE

# AUTOMATIC DRIVE POSITIONER

Terminal	Wire color	Item	Signal Input/Output	Condition	Voltage (V) (Approx)
44	G/B	Reclining motor backward signal	Output	Reclining switch backward operation (Motor operated)	Battery voltage
				Other than above	0
45	Y/B	Front lifting motor UP signal	Output	Front lifting switch upward operation (Motor operated)	Battery voltage
				Other than above	0
48	B	Ground (power)	—	—	0

## Terminals and Reference Values for Automatic Drive Positioner Control Unit

NIS0025Z

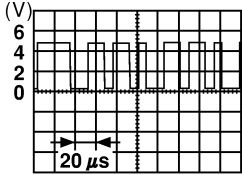
Terminal	Wire color	Item	Signal Input/Output	Condition	Voltage (V) (Approx)
1	Y	Tilt switch UP signal	Input	Tilt switch is UP operation	0
				Other than above	5
5	L/R	Mirror sensor (RH vertical) signal	Input	When mirror motor RH is UP or DOWN operation	Changes between 4.2 (close to perk) 0.5 (close to valley)
6	LG	Mirror sensor (LH vertical) signal	Input	When mirror motor LH is UP or DOWN operation	Changes between 4.2 (close to perk) 0.5 (close to valley)
7	L	Tilt sensor signal	Input	Tilt position: Top	1
				Tilt position: Bottom	3.8
9	LG	Memory switch 1 signal	Input	Memory switch 1 ON	0
				Other than above	5
10	O	UART LINE (TX)	Output	Tilt switch operated	 <p style="text-align: right; font-size: small;">SKIA0175E</p>
11	R	Telescopic switch forward signal	Input	When telescopic switch is forward operation	0
				Other than above	5
12	R/G	Memory switch indicator 1 signal	Input	When illuminate indicator 1	1
				Other than above	Battery voltage
13	P	Memory switch indicator 2 signal	Input	When illuminate indicator 2	1
				Other than above	Battery voltage
14	L	Mirror motor RH UP signal	Output	When mirror motor RH UP operation	Battery voltage
				Other than above	0
15	G	Mirror motor RH LEFT signal	Output	When mirror motor RH LEFT operation	Battery voltage
				Other than above	0
16	W/L	Mirror motor LH DOWN signal	Output	When mirror motor LH DOWN operation	Battery voltage
				Other than above	0
		Mirror motor LH RIGHT signal		When mirror motor LH RIGHT operation	Battery voltage
				Other than above	0

# AUTOMATIC DRIVE POSITIONER

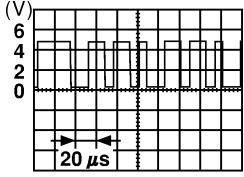
Terminal	Wire color	Item	Signal Input/Output	Condition	Voltage (V) (Approx)
17	LG	Tilt switch DOWN signal	Input	When tilt switch is DOWN position	0
				Other than above	5
21	SB	Mirror sensor (RH horizontal) signal	Input	When mirror motor RH is LEFT or RIGHT operation	Changes between 3.5 (close to left edge) 0.5 (close to right edge)
22	O/L	Mirror sensor (LH horizontal) signal	Input	When mirror motor LH is LEFT or RIGHT operation	Changes between 0.5 (close to left edge) 3.5 (close to right edge)
23	GR	Telescopic sensor input	Input	Telescopic position: Top	4.6
				Telescopic position: Bottom	0.4
24	BR/W	Set switch signal	Input	Set switch ON	0
				Other than above	5
25	LG/B	Memory switch 2 signal	Input	Memory switch 2 ON	0
				Other than above	5
26	P	UART LINE (RX)	Input	Tilt switch is operated	
27	W	Telescopic switch backward signal	Input	Telescopic switch turned to backward	0
				Other than above	5
30	GR	Mirror motor RH DOWN signal	Output	When mirror motor RH DOWN operation	Battery voltage
				Other than above	0
		Mirror motor RH RIGTH signal		When mirror motor RH RIGHT operation	Battery voltage
				Other than above	0
31	BR	Mirror motor LH UP signal	Output	When mirror motor LH UP operation	Battery voltage
				Other than above	0
32	V	Mirror motor LH LEFT signal	Output	When mirror motor LH LEFT operation	Battery voltage
				Other than above	0
33	W	Sensor power supply	Input	—	5
34	R	Power source (Fuse)	Input	—	Battery voltage
35	LG	Tilt motor UP signal	Output	Tilt switch is UP operation	Battery voltage
				Other than above	0
36	P	Telescopic motor forward signal	Output	Telescopic switch is forward operation	Battery voltage
				Other than above	0
39	L	Power source (C/B)	Input	—	Battery voltage
40	B	Ground	—	—	0
41	Y	Sensor ground	—	—	0

A  
B  
C  
D  
E  
F  
G  
H

SE

J  
K  
L  
M

## AUTOMATIC DRIVE POSITIONER

Terminal	Wire color	Item	Signal Input/Output	Condition	Voltage (V) (Approx)
42	G	Tilt motor DOWN signal	Output	Tilt switch is DOWN operation	Battery voltage
				Other than above	0
44	G	Telescopic motor backward signal	Output	Telescopic switch is backward operation	Battery voltage
				Other than above	0
48	B	Ground	—	—	0

# AUTOMATIC DRIVE POSITIONER

NIS00260

## CONSULT-II Function (AUTO DRIVE POS.)

CONSULT-II can display each diagnostic item using the diagnostic test modes shown following.

AUTO DRIVE POS. diagnostic mode	Description	Reference page
WORK SUPPORT	Changes settings for each function.	<a href="#">SE-16</a>
SELF-DIAG RESULTS	Displays driver seat control unit self-diagnosis results.	<a href="#">SE-37</a>
DATA MONITOR	Displays driver seat control unit input/output data in real time.	<a href="#">SE-38</a>
CAN DIAG SUPPORT MNTR	The result of transmit/receive diagnosis of CAN communication can be read.	<a href="#">LAN-44</a>
ACTIVE TEST	Operation of electrical loads can be checked by sending drive signal to them.	<a href="#">SE-39</a>
ECU PART NUMBER	Driver seat control unit part number can be read.	—

### CONSULT-II START PROCEDURE

Refer to [GI-38, "CONSULT-II Start Procedure"](#).

### SELF-DIAGNOSIS RESULTS

#### HOW TO READ SELF-DIAG RESULTS

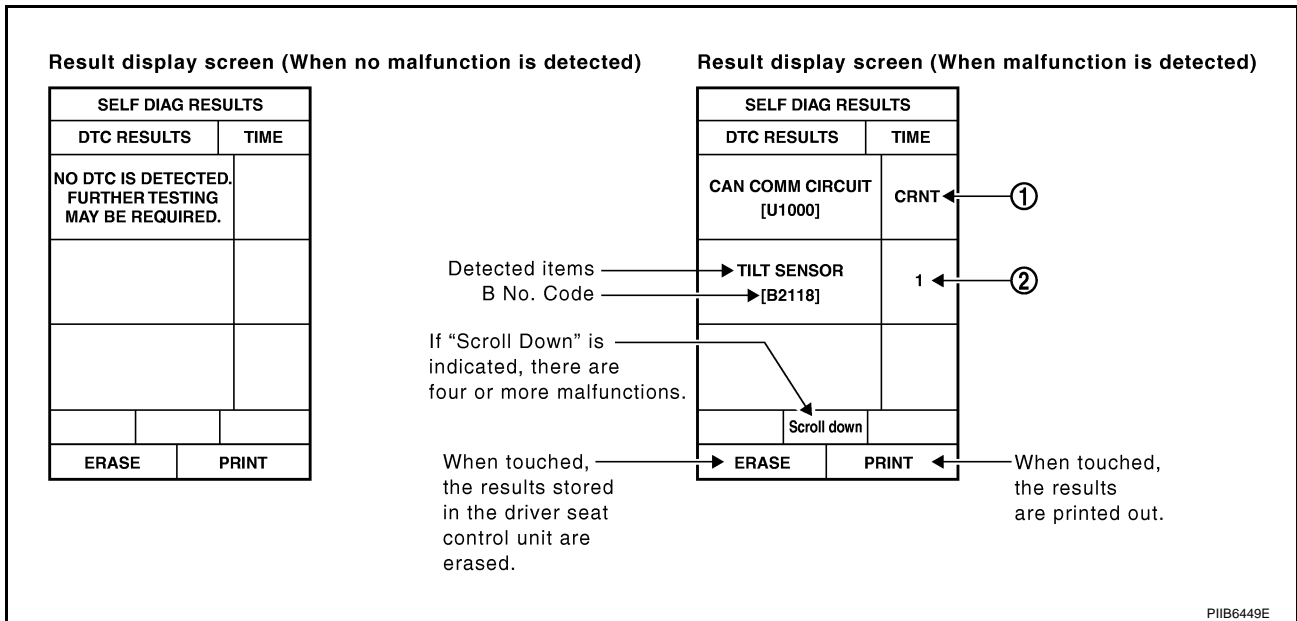

#### NOTE:

- CAN communication malfunction and detention switch malfunction are displayed on "TIME". (1)
    - If error is detected in the present, "CRNT" is displayed.
    - If error is detected in the past (present error is not detected), "PAST" is displayed.
    - If error has never been detected, nothing is displayed on "TIME".
  - Any items other than CAN communication malfunction and detention switch malfunction are counted. (2)
    - If error is detected, error detection frequency is displayed from "1" to "127" on "TIME".
    - If error has never been detected, nothing is displayed on "TIME".
    - Can clear the detected memory.
- Normal: Clear memory in normal condition, history is erased and nothing is displayed on "TIME".  
 Error: Clear memory in error condition, error is detected again and "1" is displayed on "TIME".

# AUTOMATIC DRIVE POSITIONER

## DISPLAY ITEM LIST

DTC	Self-diagnosis item (CONSULT-II indication)	DTC detection condition	Reference page
U1000	CAN COMM CIRCUIT	When driver seat control unit is not transmitting or receiving CAN communication signal for 2 seconds or more.	<a href="#">SE-42</a>
B2112	SEAT SLIDE	When any manual and automatic operations are not performed, if any motor operations of seat slide is detected for 0.1 second or more, status is judged "Output error".	<a href="#">SE-45</a> <a href="#">SE-53</a>
B2113	SEAT RECLINING	When any manual and automatic operations are not performed, if any motor operations of seat reclining is detected for 0.1 second or more, status is judged "Output error".	<a href="#">SE-46</a> <a href="#">SE-55</a>
B2114	SEAT LIFTER-FR	When any manual and automatic operations are not performed, if any motor operations of seat lifting FR is detected for 0.1 second or more, status is judged "Output error".	<a href="#">SE-47</a> <a href="#">SE-57</a>
B2115	SEAT LIFTER-RR	When any manual and automatic operations are not performed, if any motor operations of seat lifting RR is detected for 0.1 second or more, status is judged "Output error".	<a href="#">SE-49</a> <a href="#">SE-59</a>
B2116	STEERING TILT	When any manual and automatic operations are not performed, if any motor operations of steering tilt is detected for 0.1 second or more, status is judged "Output error".	<a href="#">SE-51</a>
B2118	STRG TILT SENSOR	When driver seat control unit detects 0.1V or lower, or 4.9V or higher, from tilt sensor for 0.5 seconds or more.	<a href="#">SE-63</a>
B2119	STEERING TELESCO	When driver seat control unit detects 0.1V or lower, or 4.9V or higher, from telescopic sensor for 0.5 seconds or more.	<a href="#">SE-61</a>
B2126	DETENT SW	With the A/T selector lever in P position (Detente switch OFF), if the vehicle speed of 7 km/h (4 MPH) or higher was input the detention switch input system is judged malfunctioning.	<a href="#">SE-86</a>
B2128	UART COMM	Malfunction is detected in UART communication.	<a href="#">SE-88</a>

## DATA MONITOR

### SELECTION FROM MEMU

Monitor item [OPERATION or UNIT]	Contents
SET SW	"ON/OFF" ON/OFF status judged from the setting switch signal is displayed.
MEMORY SW1	"ON/OFF" ON/OFF status judged from the seat memory switch 1 signal is displayed.
MEMORY SW2	"ON/OFF" ON/OFF status judged from the seat memory switch 2 signal is displayed.
SLIDE SW-FR	"ON/OFF" ON/OFF status judged from the sliding switch (FR) signal is displayed.
SLIDE SW-RR	"ON/OFF" ON/OFF status judged from the sliding switch (RR) signal is displayed.
RECLN SW-FR	"ON/OFF" ON/OFF status judged from the reclining switch (FR) signal is displayed.
RECLN SW-RR	"ON/OFF" ON/OFF status judged from the reclining switch (RR) signal is displayed.
LIFT FR SW-UP	"ON/OFF" ON/OFF status judged from the FR lifting switch (UP) signal is displayed.
LIFT FR SW-DN	"ON/OFF" ON/OFF status judged from the FR lifting switch (DOWN) signal is displayed.
LIFT RR SW-UP	"ON/OFF" ON/OFF status judged from the RR lifting switch (UP) signal is displayed.
LIFT RR SW-DN	"ON/OFF" ON/OFF status judged from the RR lifting switch (DOWN) signal is displayed.
MIR CON SW-UP	"ON/OFF" ON/OFF status judged from the door mirror remote control switch (UP) signal is displayed.
MIR CON SW-DN	"ON/OFF" ON/OFF status judged from the door mirror remote control switch (DOWN) signal is displayed.
MIR CON SW-RH	"ON/OFF" ON/OFF status judged from the door mirror remote control switch (RIGHT) signal is displayed.
MIR CON SW-LH	"ON/OFF" ON/OFF status judged from the door mirror remote control switch (LEFT) signal is displayed.
MIR CHNG SW-R	"ON/OFF" ON/OFF status judged from the door mirror remote control switch (switching to RIGHT) signal is displayed.

# AUTOMATIC DRIVE POSITIONER

Monitor item [OPERATION or UNIT]		Contents
MIR CHNG SW-L	"ON/OFF"	ON/OFF status judged from the door mirror remote control switch (switching to LEFT) signal is displayed.
TILT SW-UP	"ON/OFF"	ON/OFF status judged from the tilt switch (UP) signal is displayed.
TILT SW-DOWN	"ON/OFF"	ON/OFF status judged from the tilt switch (DOWN) signal is displayed.
TELESCO SW-FR	"ON/OFF"	ON/OFF status judged from the telescoping switch (FR) signal is displayed.
TELESCO SW-RR	"ON/OFF"	ON/OFF status judged from the telescoping switch (RR) signal is displayed.
DETENT SW	"ON/OFF"	The selector lever position "OFF (P position) / ON (other than P position)" judged from the detention switch signal is displayed.
STARTER SW	"ON/OFF"	Ignition key switch ON (START, ON) /OFF (IGN, ACC, or OFF) status judged from the ignition switch signal is displayed.
SLIDE PULSE	—	Value (32768) when battery connects is as standard. If it moves backward, the value increases. If it moves forward, the value decreases.
RECLN PULSE	—	Value (32768) when battery connects is as standard. If it moves backward, the value increases. If it moves forward, the value decreases.
LIFT FR PULSE	—	Value (32768) when battery connects is as standard. If it moves DOWN, the value increases. If it moves UP, the value decreases.
LIFT RR PULSE	—	Value (32768) when battery connects is as standard. If it moves DOWN, the value increases. If it moves UP, the value decreases.
MIR/SEN RH U-D	"V"	Voltage output from RH door mirror sensor (UP/DOWN) is displayed.
MIR/SEN RH R-L	"V"	Voltage output from RH door mirror sensor (LH/RH) is displayed.
MIR/SEN LH U-D	"V"	Voltage output from LH door mirror sensor (UP/DOWN) is displayed.
MIR/SEN LH R-L	"V"	Voltage output from LH door mirror sensor (LH/RH) is displayed.

## ACTIVE TEST

### CAUTION:

During vehicle driving, do not perform active test.

### NOTE:

If active test is performed, reset seat memory and key fob interlock drive positioner after performing work.

## DISPLAY ITEM LIST

Test item	Description
TILT MOTOR	The tilt motor is activated by receiving the drive signal.
TELESCO MOTOR	The telescopic motor is activated by receiving the drive signal.
SEAT SLIDE	The sliding motor is activated by receiving the drive signal.
SEAT RECLINING	The reclining motor is activated by receiving the drive signal.
SEAT LIFTER FR	The front lifting motor is activated by receiving the drive signal.
SEAT LIFTER RR	The rear lifting motor is activated by receiving the drive signal.
MIRROR MOTOR RH	The RH mirror motor moves the mirror UP/DOWN and LEFT/RIGHT by receiving the drive signal.
MIRROR MOTOR LH	The LH mirror motor moves the mirror UP/DOWN and LEFT/RIGHT by receiving the drive signal.
MEMORY SW INDCTR	The memory switch indicator is lit by receiving the drive signal.

## WORK SUPPORT

The seat slide amount at entry/exit operation setting can be changed by CONSULT-II. Refer to [SE-16. "SETTING CHANGE FUNCTION"](#).

# AUTOMATIC DRIVE POSITIONER

## Work Flow

NIS00261

1. Check the symptom and customer's requests.
2. Understand the system description. Refer to [SE-12, "System Description"](#) .
3. Perform the self-diagnosis results, using CONSULT-II. Refer to [SE-37, "CONSULT-II Function \(AUTO DRIVE POS.\)"](#) .
4. Repair or replace depending on the self-diagnostic results.
5. Based on the trouble diagnosis chart, repair or replace the cause of the malfunction. Refer to [SE-40, "Symptom Chart"](#) .
6. Does the automatic drive positioned system operate normally?  
If it is normal, GO TO 8.  
If it is not normal, GO TO 3.
7. INSPECTION END

## Symptom Chart

NIS00262

### NOTE:

Always check the "Work flow" before performing diagnosis in the following table, Refer to [SE-40, "Work Flow"](#) .

Symptom	Diagnoses / service procedure	Reference page
All of automatic operation dose not operate.	1. Check BCM power supply and ground circuit	<a href="#">SE-42</a>
	2. Check driver seat control unit power supply and ground circuit	<a href="#">SE-43</a>
	3. Check automatic drive positioner control unit power supply and ground circuit	<a href="#">SE-44</a>
Sliding function does not operate (automatically and manually).	Check sliding motor circuit	<a href="#">SE-45</a>
Reclining function does not operate (automatically and manually).	Check reclining motor circuit	<a href="#">SE-46</a>
Front lifting function does not operate (automatically and manually).	Check front lifting motor circuit	<a href="#">SE-47</a>
Rear lifting function not operate (automatically and manually).	Check rear lifting motor circuit	<a href="#">SE-49</a>
Tilt function does not operate (automatically and manually).	Check tilt motor circuit	<a href="#">SE-51</a>
Telescopic function does not operate (automatically and manually).	Check telescopic motor circuit	<a href="#">SE-50</a>
Sliding function does not operate automatically.	Check sliding sensor circuit	<a href="#">SE-53</a>
Reclining function does not operate automatically.	Check reclining sensor circuit	<a href="#">SE-55</a>
Front lifting function does not operate automatically.	Check front lifting sensor circuit	<a href="#">SE-57</a>
Rear lifting function does not operate automatically.	Check rear lifting sensor circuit	<a href="#">SE-59</a>
Tilt function does not operate automatically.	Check tilt sensor circuit	<a href="#">SE-63</a>
Telescopic function does not operate automatically.	Check telescopic sensor circuit	<a href="#">SE-61</a>
Sliding function does not operate manually.	Check sliding switch circuit	<a href="#">SE-69</a>
Reclining function does not operate manually.	Check reclining switch circuit	<a href="#">SE-71</a>
Front lifting function does not operate manually.	Check lifting switch (front) circuit	<a href="#">SE-73</a>
Rear lifting function does not operate manually.	Check lifting switch (rear) circuit	<a href="#">SE-75</a>
Tilt function does not operate manually.	Check tilt switch circuit	<a href="#">SE-79</a>
Telescopic function does not operate manually.	Check telescopic switch circuit	<a href="#">SE-77</a>
All of seat operation dose not operate manually.	Check power seat switch ground circuit	<a href="#">SE-76</a>
Only seat memory and set switch operation does not operate.	1. Perform storing memory	<a href="#">SE-13</a>
	2. Check seat memory and set switch circuit	<a href="#">SE-81</a>
Seat memory indicator lamps 1 and 2 do not illuminate.	Check seat memory indicator lamp circuit	<a href="#">SE-82</a>



# AUTOMATIC DRIVE POSITIONER

Symptom	Diagnoses / service procedure	Reference page
Entry/Exiting operation does not operated.	1. Check system setting	<a href="#">SE-16</a>
	2. Perform initialization	<a href="#">SE-16</a>
	3. Check front door switch (driver side) circuit	<a href="#">SE-87</a>
LH or RH door mirror face does not produce the stored angle, during the memory operation.	1. Check door mirror sensor power supply and ground circuit	<a href="#">SE-84</a>
	2. Check door mirror sensor LH circuit	<a href="#">SE-64</a>
	3. Check door mirror sensor RH circuit	<a href="#">SE-67</a>
	4. Replace automatic drive positioner control unit	<a href="#">SE-11</a>
Intelligent key interlock operation does not operate. (Other automatic operation and Intelligent Key system are normal)	Perform storing memory	<a href="#">SE-13</a>
Lumbar support does not operate	Check Lumbar support circuit	<a href="#">SE-90</a>

A  
B  
C  
D  
E  
F  
G  
H  
SE  
J  
K  
L  
M

SE

# AUTOMATIC DRIVE POSITIONER

## CAN Communication Inspection Using CONSULT-II (Self-Diagnosis)

NIS00263

### 1. SELF-DIAGNOSTIC RESULT CHECK

#### CAUTION:

If CONSULT-II is used with no connection of CONSULT-II CONVERTER, malfunctions might be detected in self-diagnosis depending on control unit which carry out CAN communication.

1. Connect to CONSULT-II, and select "AUTO DRIVE POS." on the "SELECT DIAG SYSTEM" screen.
2. Select "SELF-DIAG RESULTS" on "SELECT DIAG MODE" screen.
3. Check display content in self-diagnostic results.

CONSULT-II display code	Diagnosis item
U1000	INITIAL DIAG
	TRANSMIT DIAG
	BCM/SEC
	METER/M&A
	TCM

#### Contents displayed

No malfunction>>Inspection End.

Malfunction in CAN communication system>>After printing the monitor items, go to "CAN System". Refer to [LAN-50, "CAN System Specification Chart"](#).

## Check BCM Power Supply and Ground Circuit

NIS00264

### 1. CHECK FUSE

Check if any of the following fuses in the BCM are blown.

Unit	Power source	Fuse No.
BCM	Battery power supply	F (50A)
	Battery power supply	21 (10A)
	Ignition switch ON or STRAT signal	1 (15A)
	Ignition switch ACC or ON signal	6 (10A)

#### NOTE:

Refer to [SE-11, "Component Parts And Harness Connector Location"](#).

#### OK or NG

OK >> GO TO 2.

NG >> If fuse is blown, be sure to eliminate cause of malfunction before installing new fuse. Refer to [PG-3, "POWER SUPPLY ROUTING CIRCUIT"](#).

# AUTOMATIC DRIVE POSITIONER

## 2. CHECK POWER SUPPLY CIRCUIT (BCM)

1. Turn ignition switch OFF.
2. Disconnect BCM connector.
3. Check voltage between BCM connector and ground.

Terminals		Condition of ignition switch	Voltage (V) (Approx.)
(+)			
BCM connector	Terminal		
M1	38	ON	Battery voltage
	11	ACC	
M2	42	OFF	
	55		

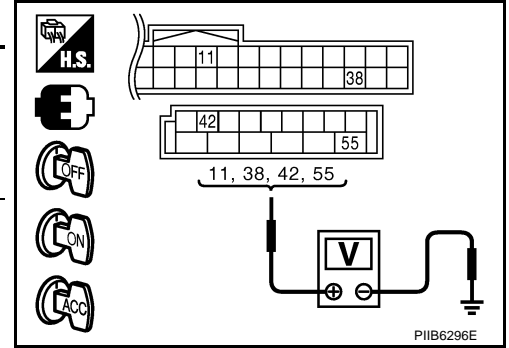

**OK or NG**

- OK >> GO TO 3.  
 NG >> Repair or replace the harness between BCM and fuse.

## 3. CHECK GROUND CIRCUIT (BCM)

Check continuity between BCM connector and ground.

BCM connector	Terminal	Ground	Continuity
M2	52		Yes

**OK or NG**

- OK >> BCM power supply and ground circuit are OK.  
 NG >> Repair or replace the harness between BCM and ground.

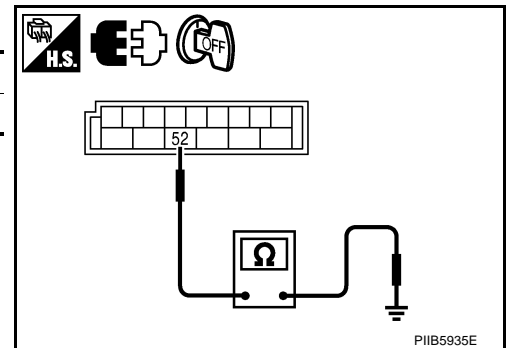

## Check Driver Seat Control Unit Power Supply and Ground Circuit

NIS00265

### 1. CHECK POWER SUPPLY CIRCUIT

1. Turn ignition switch OFF.
2. Disconnect driver seat control unit connector.
3. Check voltage between driver seat control unit connector and ground.

Terminals		Condition of ignition switch	Voltage (V) (Approx.)
(+)			
Driver seat control unit connector	Terminal		
B205	33	Ground	Battery voltage
	40		

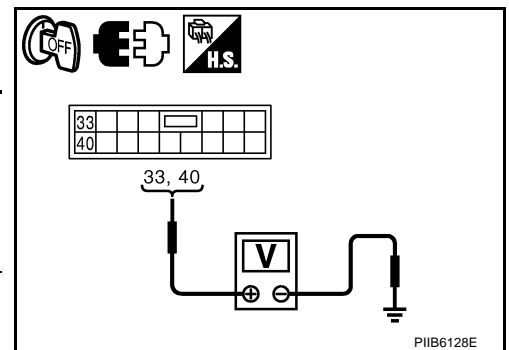

**OK or NG**

- OK >> GO TO 2.  
 NG >> Check the following.
- Repair or replace harness between driver seat control unit and fuse block (J/B).
  - Circuit breaker.

# AUTOMATIC DRIVE POSITIONER

## 2. CHECK GROUND CIRCUIT

1. Turn ignition switch OFF.
2. Check continuity between the driver seat control unit connector and ground.

Driver seat control unit connector	Terminal	Ground	Continuity
B204	32	Ground	Yes
B205	48		

### OK or NG

- OK >> Driver seat control unit power supply and ground circuit are OK.
- NG >> Repair or replace harness between driver seat control unit and ground.

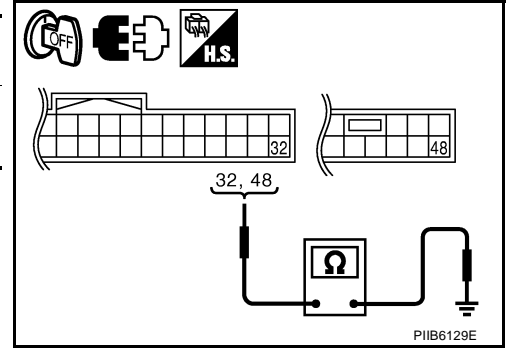

## Check Automatic Drive Positioner Control Unit Power Supply and Ground Circuit

NIS00266

### 1. CHECK POWER SUPPLY CIRCUIT

1. Turn ignition switch OFF.
2. Disconnect automatic drive positioner control unit connector.
3. Check voltage between automatic drive positioner control unit connector and ground.

Terminals		Voltage (V) (Approx.)
Automatic drive positioner control unit connector	Terminal	
M7	34 39	Ground Battery voltage

### OK or NG

- OK >> GO TO 2.
- NG >> Repair or replace harness between automatic drive positioner control unit and fuse block (J/B).

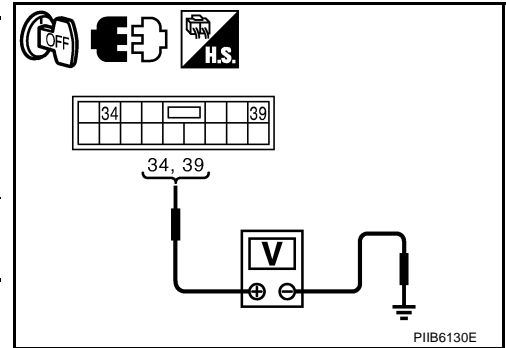

## 2. CHECK GROUND CIRCUIT

Check continuity between the automatic drive positioner control unit connector and ground.

Automatic drive positioner control unit connector	Terminal	Ground	Continuity
M7	40 48	Ground	Yes

### OK or NG

- OK >> Automatic drive positioner control unit power supply and ground circuit are OK.
- NG >> Repair or replace harness between automatic drive positioner control unit and ground.

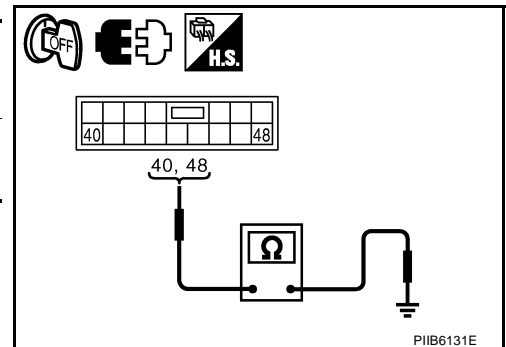

# AUTOMATIC DRIVE POSITIONER

NIS00267

## Check Sliding Motor Circuit

### 1. CHECK SEAT SLIDING MECHANISM

Check the following.

- Operation malfunction caused by sliding rail deformation, pinched harness or other foreign materials
- Operation malfunction caused by foreign materials adhered to the sliding motor or sliding rail connector rod
- Operation malfunction and interference with other parts by poor installation

OK or NG

OK >> GO TO 2.

NG >> Repair or replace the malfunctioning part and check again.

### 2. CHECK FUNCTION

 With CONSULT-II

Check operation with "SEAT SLIDE" in ACTIVE TEST.

Test item	Description
SEAT SLIDE	The sliding motor is activated by receiving the drive signal.

OK or NG

OK >> Sliding motor circuit is OK.

NG >> GO TO 3.

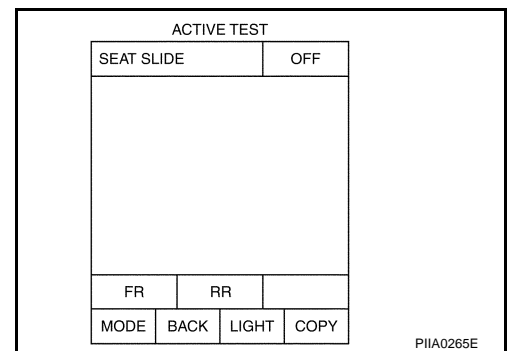

### 3. CHECK SLIDING MOTOR CIRCUIT HARNESS CONTINUITY

1. Turn ignition switch OFF.
2. Disconnect driver seat control unit and sliding motor connector.
3. Check continuity between driver seat control unit connector and sliding motor connector.

A		B		Continuity
Driver seat control unit connector	Terminal	Sliding motor connector	Terminal	
B205	35	B207	35	Yes
	42		42	

4. Check continuity between driver seat control unit connector and ground.

A		Ground	Continuity
Driver seat control unit connector	Terminal		
B205	35	No	
	42		

OK or NG

OK >> GO TO 4.

NG >> Repair or replace harness.

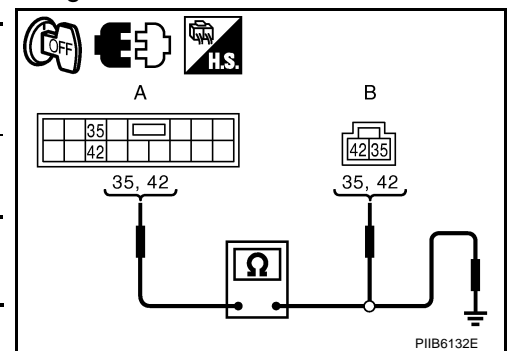

# AUTOMATIC DRIVE POSITIONER

## 4. CHECK DRIVER SEAT CONTROL UNIT OUTPUT SIGNAL

1. Connect the driver seat control unit connector.
2. Check voltage between driver seat control unit connector and ground.

Driver seat control unit connector	Terminals		Condition	Voltage (V) (Approx.)
	(+)	(-)		
B205	35	Ground	Sliding switch ON (FORWARD operation)	Battery voltage
			Other than above	0
	42		Sliding switch ON (BACKWARD operation)	Battery voltage
			Other than above	0

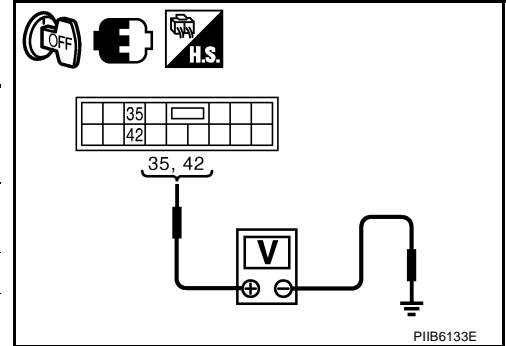

**OK or NG**

- OK >> Replace sliding motor.
- NG >> Replace driver seat control unit.

## Check Reclining Motor Circuit

NIS00268

### 1. CHECK SEAT RECLINING MECHANISM

Check the following.

- Operation malfunction caused by an interference with the center pillar or center console
- Operation malfunction and interference with other parts by poor installation

**OK or NG**

- OK >> GO TO 2.
- NG >> Repair or replace the malfunctioning part and check again.

### 2. CHECK FUNCTION

**With CONSULT-II**

Check operation with "SEAT RECLINING" in ACTIVE TEST.

Test item	Description
SEAT RECLINING	The reclining motor is activated by receiving the drive signal.

**OK or NG**

- OK >> Reclining motor circuit is OK.
- NG >> GO TO 3.

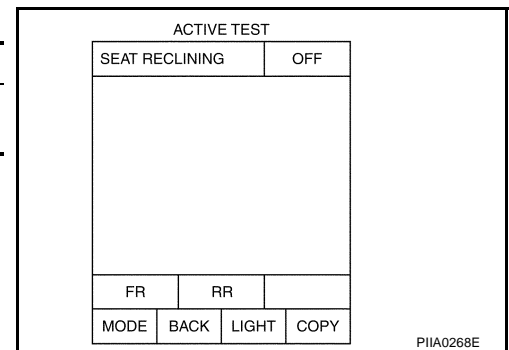

# AUTOMATIC DRIVE POSITIONER

## 3. CHECK RECLINING MOTOR CIRCUIT HARNESS CONTINUITY

1. Turn ignition switch OFF.
2. Disconnect driver seat control unit and reclining motor connector.
3. Check continuity between driver seat control unit connector and reclining motor connector.

A		B		Continuity
Driver seat control unit connector	Terminal	Reclining motor connector	Terminal	
B205	36	B208	36	Yes
	44		44	

4. Check continuity between driver seat control unit connector and ground.

A		Ground	Continuity
Driver seat control unit connector	Terminal		
B205	36		No
	44		

OK or NG

- OK >> GO TO 4.  
 NG >> Repair or replace harness.

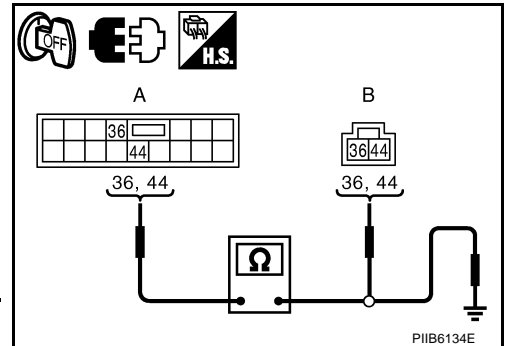

## 4. CHECK DRIVER SEAT CONTROL UNIT OUTPUT SIGNAL

1. Connect the driver seat control unit connector.
2. Check voltage between driver seat control unit connector and ground.

Driver seat control unit connector	Terminals		Condition	Voltage (V) (Approx.)
	(+)	(-)		
B205	36	Ground	Reclining switch ON (FORWARD operation)	Battery voltage
			Other than above	0
	44		Reclining switch ON (BACKWARD operation)	Battery voltage
			Other than above	0

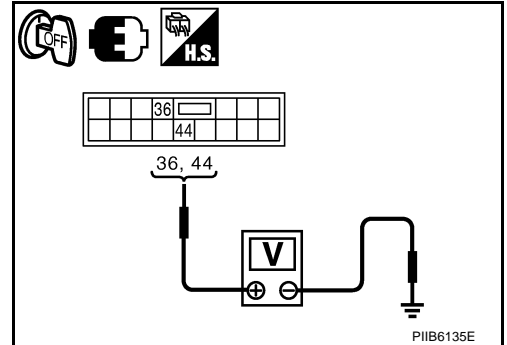

OK or NG

- OK >> Replace reclining motor.  
 NG >> Replace driver seat control unit.

## Check Front Lifting Motor Circuit

NIS00269

### 1. CHECK FRONT END SEAT LIFTING MECHANISM

Check the following.

- Operation malfunction caused by lifter mechanism deformation, pinched harness or other foreign materials
- Operation malfunction caused by foreign materials adhered to the front lifting motor or lead screws
- Operation malfunction and interference with other parts by installation

OK or NG

- OK >> GO TO 2.  
 NG >> Repair or replace the malfunctioning part and check again.

# AUTOMATIC DRIVE POSITIONER

## 2. CHECK FUNCTION

### With CONSULT-II

Check operation with "SEAT LIFTER FR" in ACTIVE TEST.

Test item	Description
SEAT LIFTER FR	The front lifting motor is activated by receiving the drive signal.

#### OK or NG

- OK >> Front lifting motor circuit is OK.
- NG >> GO TO 3.

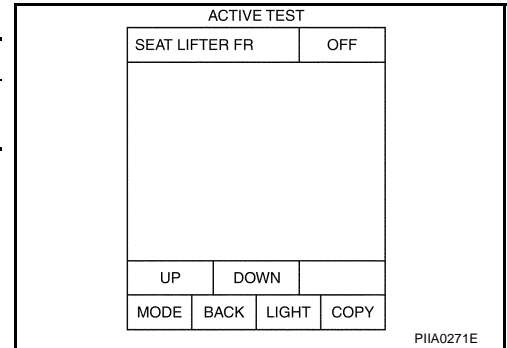

## 3. CHECK FRONT LIFTING MOTOR CIRCUIT HARNESS CONTINUITY

- Turn ignition switch OFF.
- Disconnect driver seat control unit and front lifting motor connector.
- Check continuity between driver seat control unit connector and front lifting motor connector.

A		B		Continuity
Driver seat control unit connector	Terminal	Front lifting motor connector	Terminal	
B205	37	B209	37	Yes
	45		45	

- Check continuity between driver seat control unit connector and ground.

A		Ground	Continuity
Driver seat control unit connector	Terminal		
B205	37		No
	45		

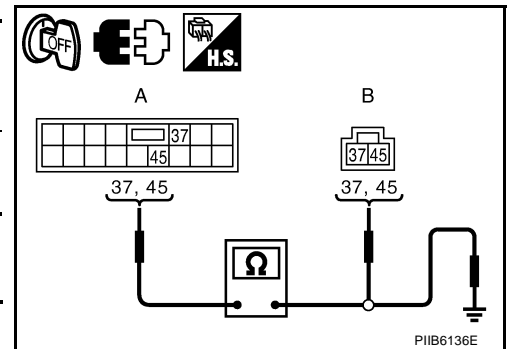

#### OK or NG

- OK >> GO TO 4.
- NG >> Repair or replace harness.

## 4. CHECK DRIVER SEAT CONTROL UNIT OUTPUT SIGNAL

- Connect the driver seat control unit connector.
- Check voltage between driver seat control unit connector and ground.

Driver seat control unit connector	Terminals		Condition	Voltage (V) (Approx)
	(+)	(-)		
B205	37	Ground	Lifting switch (front) ON (DOWN operation)	Battery voltage
			Other than above	0
	45		Lifting switch (front) ON (UP operation)	Battery voltage
			Other than above	0

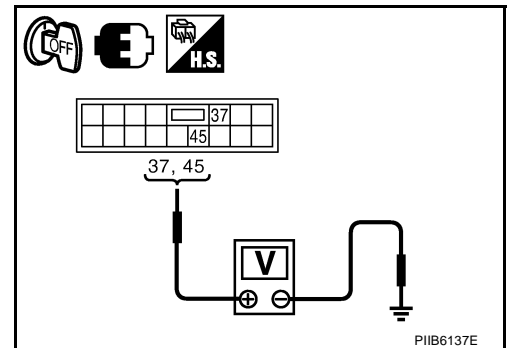

#### OK or NG

- OK >> Replace front lifting motor.
- NG >> Replace driver seat control unit.



# AUTOMATIC DRIVE POSITIONER

NIS0026A

## Check Rear Lifting Motor Circuit

### 1. CHECK REAR SEAT LIFTING MECHANISM

Check the following.

- Operation malfunction caused by lifter mechanism deformation or pinched harness or other foreign materials
- Operation malfunction caused by foreign materials adhered to the rear lifting motor or lead screws
- Operation malfunction and interference with other parts by poor installation

OK or NG

OK >> GO TO 2.

NG >> Repair or replace the malfunctioning part and check again.

### 2. CHECK FUNCTION

Ⓟ With CONSULT-II

Check operation with "SEAT LIFTER RR" in ACTIVE TEST.

Test item	Description
SEAT LIFTER RR	The rear lifting motor is activated by receiving the drive signal.

OK or NG

OK >> Rear lifting motor circuit is OK.

NG >> GO TO 3.

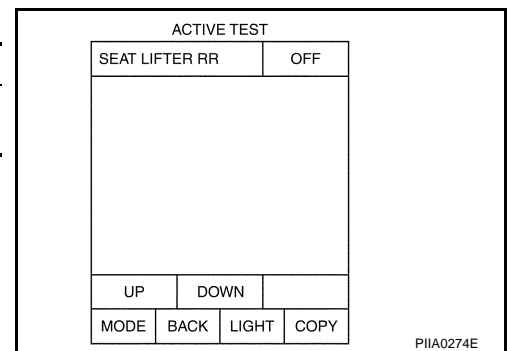

### 3. CHECK REAR LIFTING MOTOR CIRCUIT HARNESS CONTINUITY

1. Turn ignition switch OFF.
2. Disconnect driver seat control unit and rear lifting motor connector.
3. Check continuity between driver seat control unit connector and rear lifting motor connector.

A		B		Continuity
Driver seat control unit connector	Terminal	Rear lifting motor connector	Terminal	
B205	38	B210	38	Yes
	39		39	

4. Check continuity between driver seat control unit connector and ground.

A		Ground	Continuity
Driver seat control unit connector	Terminal		
B205	38	No	
	39		

OK or NG

OK >> GO TO 4.

NG >> Repair or replace harness.

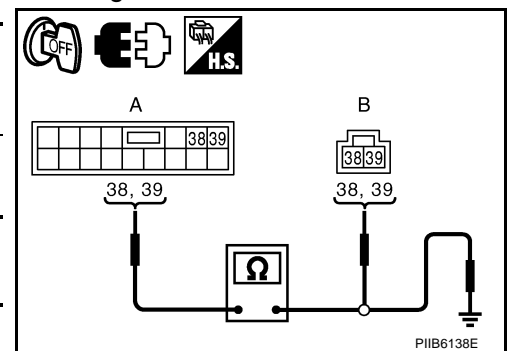

# AUTOMATIC DRIVE POSITIONER

## 4. CHECK DRIVER SEAT CONTROL UNIT OUTPUT SIGNAL

1. Connect the driver seat control unit connector.
2. Check voltage between driver seat control unit connector and ground.

Driver seat control unit connector	Terminals		Condition	Voltage (V) (Approx.)
	(+)	(-)		
B205	38	Ground	Lifting switch (rear) ON (UP operation)	Battery voltage
			Other than above	0
	39		Lifting switch (rear) ON (DOWN operation)	Battery voltage
			Other than above	0

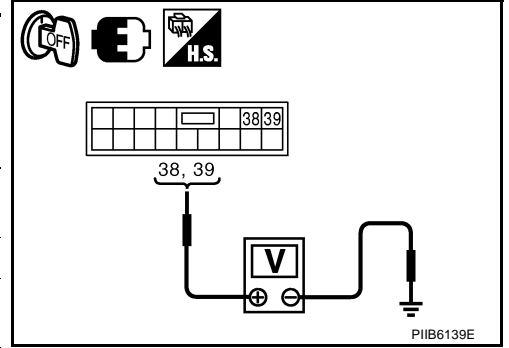

### OK or NG

- OK >> Replace rear lifting motor.
- NG >> Replace driver seat control unit.

## Check Telescopic Motor Circuit

NIS0026B

### 1. CHECK STEERING WHEEL TELESCOPIC MECHANISM

Check following.

- Operation malfunction caused by steering wheel telescopic mechanism deformation or pinched harness or other foreign materials
- Operation malfunction and interference with other parts by poor installation

### OK or NG

- OK >> GO TO 2.
- NG >> Repair the malfunctioning part and check again.

### 2. CHECK FUNCTION

#### With CONSULT-II

Check operation with "TELESCO MOTOR" in ACTIVE TEST.

Test item	Description
TELESCO MOTOR	The telescopic motor is activated by receiving the drive signal.

### OK or NG

- OK >> Steering telescopic motor circuit is OK.
- NG >> GO TO 3.

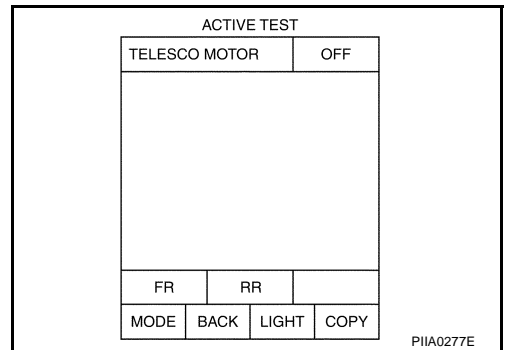

# AUTOMATIC DRIVE POSITIONER

## 3. CHECK TELESCOPIC MOTOR HARNESS CONTINUITY

1. Turn ignition switch OFF.
2. Disconnect automatic drive positioner control unit and tilt motor and telescopic motor connector.
3. Check continuity between automatic drive positioner control unit connector and tilt motor and telescopic motor connector.

A		B		Continuity
Automatic drive positioner control unit connector	Terminal	Telescopic motor connector	Terminal	
M7	36	M45	1	Yes
	44		2	

4. Check continuity between automatic drive positioner control unit connector and ground.

A		Ground	Continuity
Automatic drive positioner control unit connector	Terminal		
M7	36		No
	44		

**OK or NG**

OK >> GO TO 4.

NG >> Repair or replace harness between automatic drive positioner control unit and tilt motor and telescopic motor.

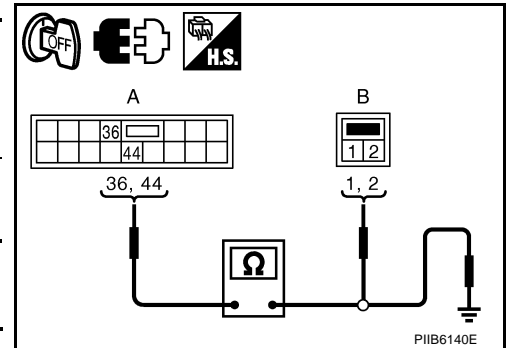

## 4. CHECK BCM OUTPUT SIGNAL

1. Connect the automatic drive positioner control unit connector.
2. Check voltage between automatic drive positioner control unit connector and ground.

Automatic drive positioner control unit connector	Terminals		Telescopic switch condition	Voltage (V) (Approx.)
	(+)	(-)		
M7	36	Ground	FORWARD	Battery voltage
			Other than above	0
	44		BACKWARD	Battery voltage
			Other than above	0

**OK or NG**

OK >> Replace tilt and telescopic motor.

NG >> Replace automatic drive positioner control unit.

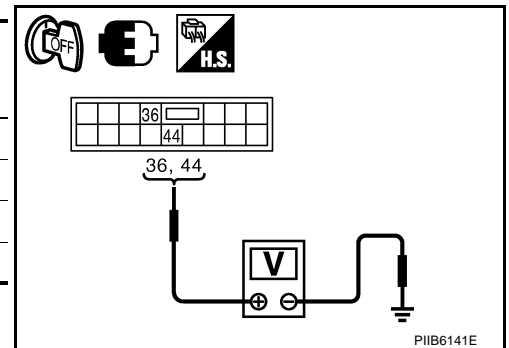

## Check Tilt Motor Circuit

### 1. CHECK STEERING WHEEL TILT MECHANISM

Check following.

- Operation malfunction caused by steering wheel tilt mechanism deformation or pinched harness and other foreign materials
- Operation malfunction and interference with other parts by poor installation

**OK or NG**

OK >> GO TO 2.

NG >> Repair the malfunctioning part.

# AUTOMATIC DRIVE POSITIONER

## 2. CHECK FUNCTION

**With CONSULT-II**

Check operation with "TILT MOTOR" in ACTIVE TEST.

Test item	Description
TILT MOTOR	The tilt motor is activated by receiving the drive signal.

**OK or NG**

- OK >> Steering tilt motor circuit is OK.
- NG >> GO TO 3.

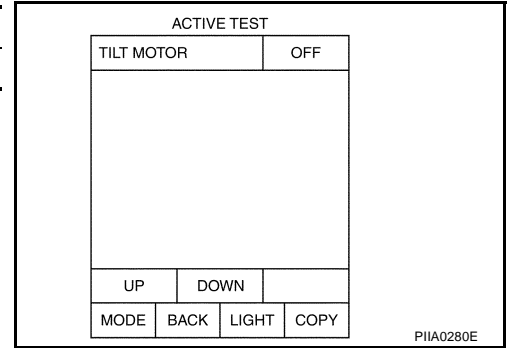

## 3. CHECK TILT MOTOR CIRCUIT HARNESS CONTINUITY

1. Turn ignition switch OFF.
2. Disconnect automatic drive positioner control unit connector and tilt motor connector.
3. Check continuity between automatic drive positioner control unit connector and tilt motor connector.

A		B		Continuity
Automatic drive positioner control unit connector	Terminal	Tilt motor connector	Terminal	
M7	35	M36	2	Yes
	42		1	

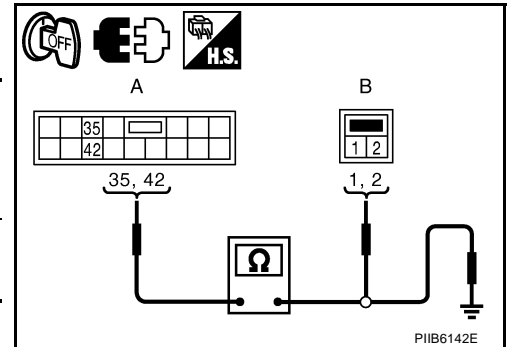

4. Check continuity between automatic drive positioner control unit connector and ground.

A		Ground	Continuity
Automatic drive positioner control unit connector	Terminal		
M7	35		No
	42		

**OK or NG**

- OK >> GO TO 4.
- NG >> Repair or replace harness between automatic drive positioner control unit and tilt motor.

# AUTOMATIC DRIVE POSITIONER

## 4. CHECK AUTOMATIC DRIVE POSITIONER CONTROL UNIT OUTPUT SIGNAL

1. Connect automatic drive positioner control unit connector and tilt motor connector.
2. Check voltage between automatic drive positioner control unit connector and ground.

Automatic drive positioner C/U connector	Terminals		Tilt switch condition	Voltage (V) (Approx.)
	(+)	(-)		
M7	35	Ground	UP	Battery voltage
			Other than above	0
	42		DOWN	Battery voltage
			Other than above	0

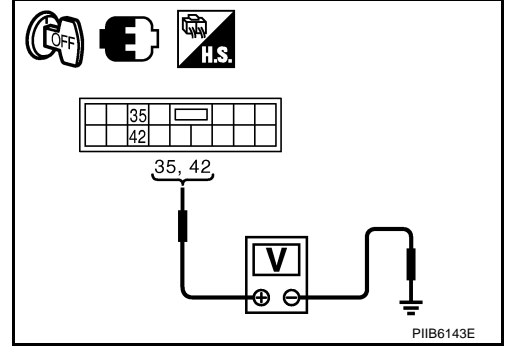

OK or NG

- OK >> Replace tilt motor.
- NG >> Replace automatic drive positioner control unit.

## Check Sliding Sensor Circuit

### 1. CHECK FUNCTION

**With CONSULT-II**

Check operation with "SLIDE PULSE" on the DATA MONITOR to make sure the pulse changes.

Monitor item [OPERATION or UNIT]	Contents
SLIDE PULSE	— The seat sliding position (pulse) judged from the sliding sensor signal is displayed

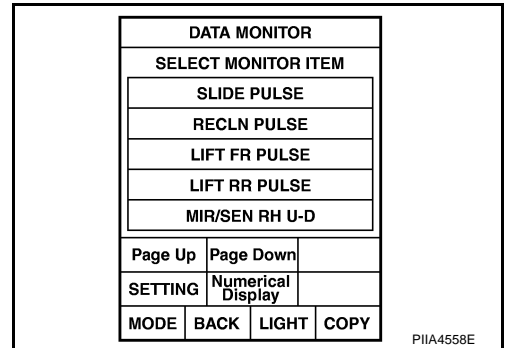

**Without CONSULT-II**

1. Turn ignition switch OFF.
2. Check signal between driver seat control unit connector and ground, with oscilloscope.

Driver seat control unit connector	Terminals		Condition	Signal (Reference value)
	(+)	(-)		
B204	24	Ground	Sliding motor operation	

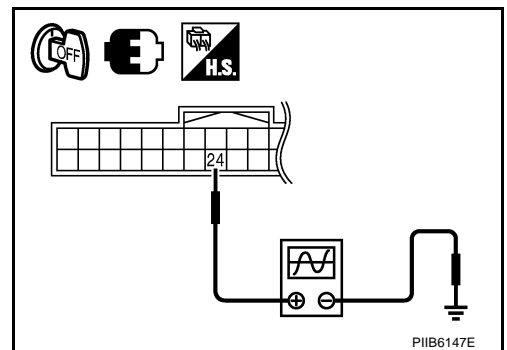

OK or NG

- OK >> Sliding sensor circuit is OK.
- NG >> GO TO 2.

# AUTOMATIC DRIVE POSITIONER

## 2. CHECK SLIDING SENSOR CIRCUIT HARNESS CONTINUITY

1. Disconnect driver seat control unit connector and sliding sensor front lifting sensor connector.
2. Check continuity between driver seat control unit connector and sliding sensor front lifting sensor connector.

A		B		Continuity
Driver seat control unit connector	Terminal	Sliding sensor · front lifting sensor connector	Terminal	
B204	24	B214	24	Yes
	31		31	

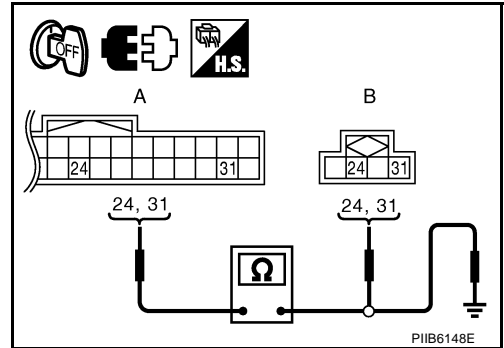

3. Check continuity between driver seat control unit connector and ground.

A		Ground	Continuity
Driver seat control unit connector	Terminal		
B204	24		No
	31		

**OK or NG**

- OK >> GO TO 3.
- NG >> Repair or replace harness.

## 3. CHECK DRIVER SEAT CONTROL UNIT OUTPUT

1. Connect driver seat control unit connector.
2. Check voltage between driver seat control unit connector and ground.

Terminals			Voltage (V) (Approx.)
(+)		(-)	
Driver seat control unit connector	Terminal		
B204	24	Ground	5

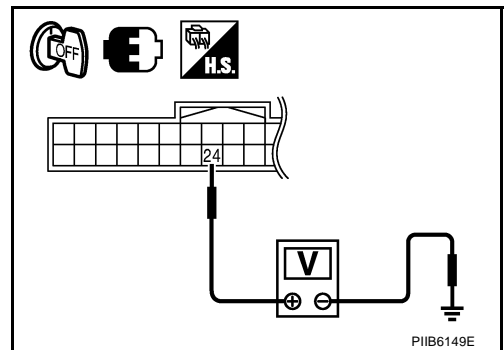

**OK or NG**

- OK >> Replace sliding sensor front lifting sensor.
- NG >> Replace automatic drive positioner control unit.

# AUTOMATIC DRIVE POSITIONER

## Check Reclining Sensor Circuit

NIS0026E

### 1. CHECK FUNCTION

#### With CONSULT-II

Check operation with "RECLN PULSE" on the DATA MONITOR to make sure the pulse changes.

Monitor item [OPERATION or UNIT]	Contents
RECLN PULSE	—
	The seat reclining position (pulse) judged from the reclining sensor is displayed

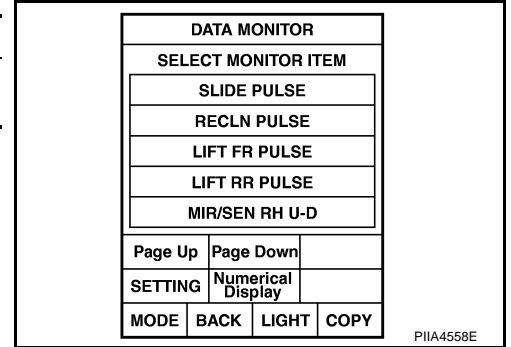

#### Without CONSULT-II

1. Turn ignition switch OFF.
2. Check signal between driver seat control unit connector and ground, with oscilloscope.

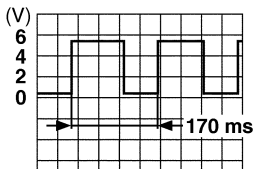
Driver seat control unit connector	Terminals		Condition	Signal (Reference value)
	(+)	(-)		
B204	9	Ground	Reclining motor operation	 <p style="text-align: right; font-size: small;">PIIB2807E</p>

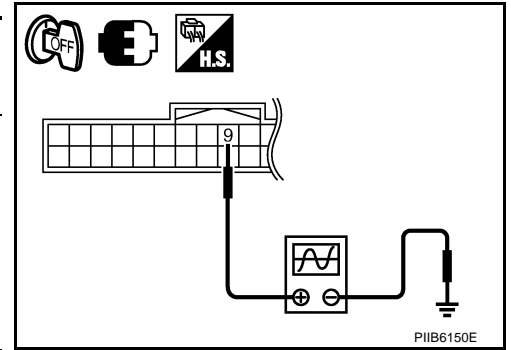

#### OK or NG

- OK >> Reclining sensor circuit is OK.
- NG >> GO TO 2.

# AUTOMATIC DRIVE POSITIONER

## 2. CHECK RECLINING MOTOR SENSOR CIRCUIT HARNESS CONTINUITY

1. Disconnect driver seat control unit and reclining sensor connector.
2. Check continuity between driver seat control unit connector and reclining sensor connector.

A		B		Continuity
Driver seat control unit connector	Terminal	Reclining sensor connector	Terminal	
B204	9	B222	9	Yes
	31		31	

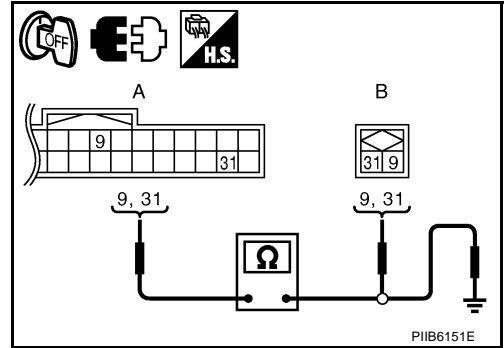

3. Check continuity between driver seat control unit connector and ground.

A		Ground	Continuity
Driver seat control unit connector	Terminal		
B204	9		No
	31		

**OK or NG**

- OK >> GO TO 3.
- NG >> Repair or replace harness.

## 3. CHECK DRIVER SEAT CONTROL UNIT OUTPUT

1. Connect driver seat control unit connector.
2. Check voltage between driver seat control unit connector and ground.

Terminals			Voltage (V) (Approx.)
(+)		(-)	
Driver seat control unit connector	Terminal		
B204	9	Ground	5

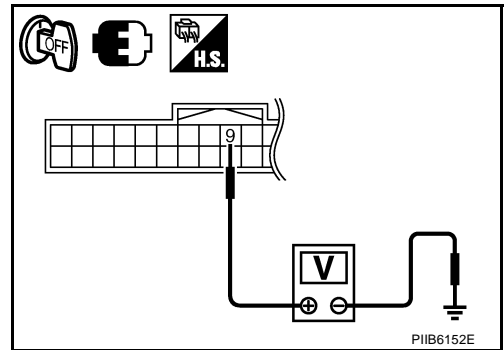

**OK or NG**

- OK >> Replace reclining sensor.
- NG >> Replace automatic drive positioner control unit.



# AUTOMATIC DRIVE POSITIONER

## Check Front Lifting Sensor Circuit

NIS0026F

### 1. CHECK FUNCTION

**With CONSULT-II**

Check operation with "LIFT FR PULSE" on the DATA MONITOR to make sure the pulse changes.

Monitor item [OPERATION or UNIT]	Contents
LIFT FR PULSE	— The front lifting position (pulse) judged from the lifting sensor (front) is displayed

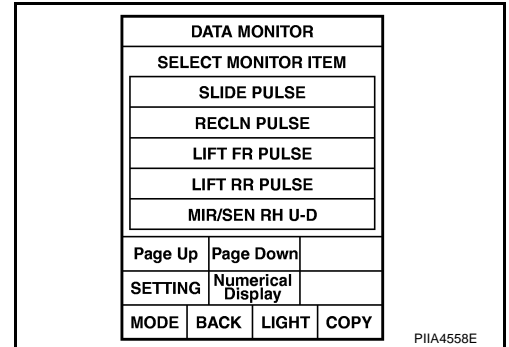

**Without CONSULT-II**

- Turn ignition switch OFF.
- Check signal between driver seat control unit connector and ground, with oscilloscope.

Sliding sensor front lifting sensor	Terminals		Condition	Signal (Reference value)
	(+)	(-)		
B214	25	Ground	Front lifting motor operation	

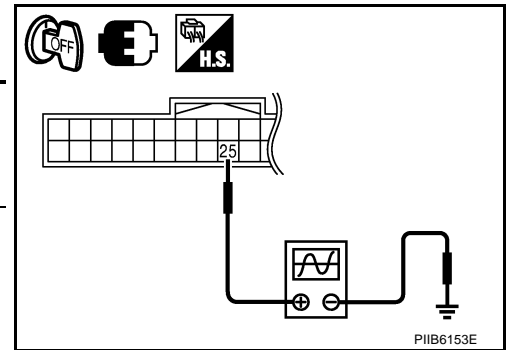

**OK or NG**

- OK >> Sliding sensor front lifting sensor is OK.
- NG >> GO TO 2.

# AUTOMATIC DRIVE POSITIONER

## 2. CHECK FRONT LIFTING MOTOR SENSOR CIRCUIT HARNESS CONTINUITY

1. Disconnect driver seat control unit and sliding sensor front lifting sensor connector.
2. Check continuity between driver seat control unit connector and sliding sensor front lifting sensor connector.

A		B		Continuity
Driver seat control unit connector	Terminal	Sliding sensor · front lifting sensor connector	Terminal	
B204	25	B214	25	Yes
	31		31B	

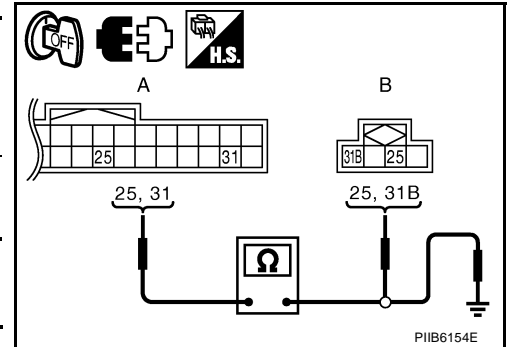

3. Check continuity between driver seat control unit connector and ground.

A		Ground	Continuity
Driver seat control unit connector	Terminal		
B204	25		No
	31		

**OK or NG**

- OK >> GO TO 3.
- NG >> Repair or replace harness.

## 3. CHECK DRIVER SEAT CONTROL UNIT OUTPUT

1. Connect driver seat control unit connector.
2. Check voltage between driver seat control unit connector and ground.

Terminals			Voltage (V) (Approx.)
(+)		(-)	
Driver seat control unit connector	Terminal		
B204	25	Ground	5

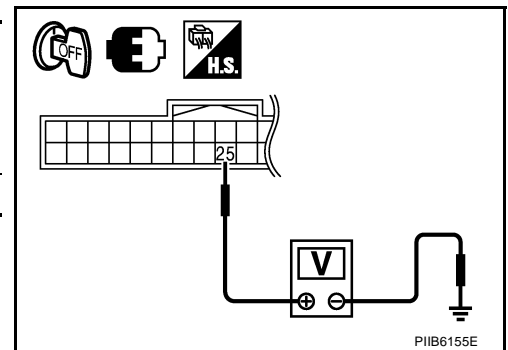

**OK or NG**

- OK >> Replace sliding sensor front lifting sensor.
- NG >> Replace automatic drive positioner control unit.

# AUTOMATIC DRIVE POSITIONER

## Check Rear Lifting Sensor Circuit

NIS0026G

### 1. CHECK FUNCTION

#### With CONSULT-II

Check operation with "LIFT RR PULSE" on the DATA MONITOR to make sure pulse changes.

Monitor item [OPERATION or UNIT]		
LIFT RR PULSE	—	The rear lifting position (pulse) judged from the lifting sensor (rear) is displayed.

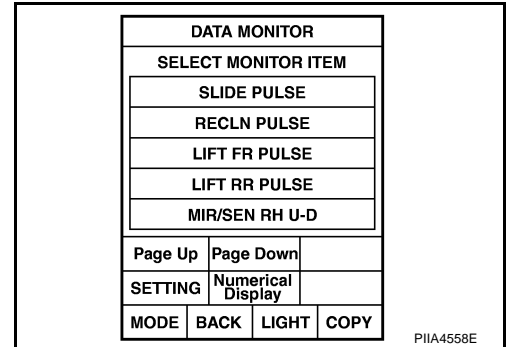

#### Without CONSULT-II

1. Turn ignition switch OFF.
2. Check signal between driver seat control unit connector and ground, with oscilloscope.

Driver seat control unit connector	Terminals		Condition	Signal (Reference value)
	(+)	(-)		
B204	10	Ground	Rear lifting motor operation	<p style="text-align: right; font-size: small;">PIIA3278E</p>

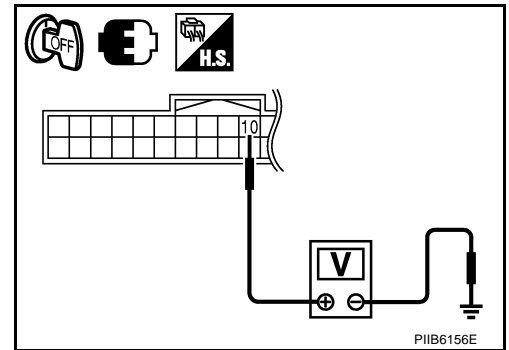

#### OK or NG

- OK >> Rear lifting sensor circuit is OK.  
 NG >> GO TO 2.

# AUTOMATIC DRIVE POSITIONER

## 2. CHECK REAR LIFTING MOTOR SENSOR CIRCUIT HARNESS CONTINUITY

1. Disconnect driver seat control unit and rear lifting sensor connector.
2. Check continuity between driver seat control unit connector and rear lifting sensor connector.

A		B		Continuity
Driver seat control unit connector	Terminal	Rear lifting sensor connector	Terminal	
B204	10	B218	10	Yes
	31		31	

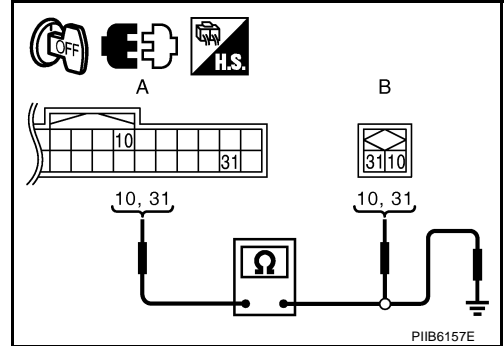

3. Check continuity between driver seat control unit connector and ground.

A		Ground	Continuity
Driver seat control unit connector	Terminal		
B204	10		No
	31		

OK or NG

- OK >> GO TO 3.
- NG >> Repair or replace harness.

## 3. CHECK DRIVER SEAT CONTROL UNIT OUTPUT

1. Connect driver seat control unit connector.
2. Check voltage between driver seat control unit connector and ground.

Terminals			Voltage (V) (Approx.)
(+)		(-)	
Driver seat control unit connector	Terminal		
B204	10	Ground	5

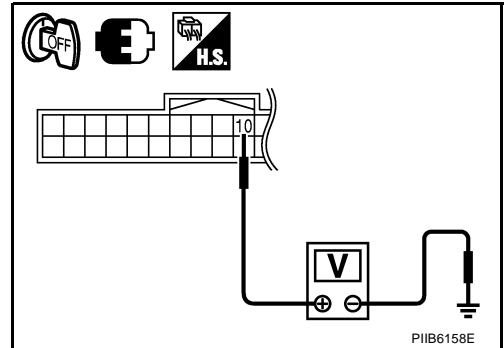

OK or NG

- OK >> Replace rear lifting sensor.
- NG >> Replace automatic drive positioner control unit.

# AUTOMATIC DRIVE POSITIONER

NIS0026H

## Check Telescopic Sensor Circuit

### 1. CHECK FUNCTION

#### With CONSULT-II

Operate the telescopic switch with "TELESCO SEN" on the DATA MONITOR to make sure the voltage changes.

Monitor item [OPERATION or UNIT]	Contents	
TELESCO SEN	"V"	The telescoping position (voltage) judged from the telescoping sensor signal is displayed.

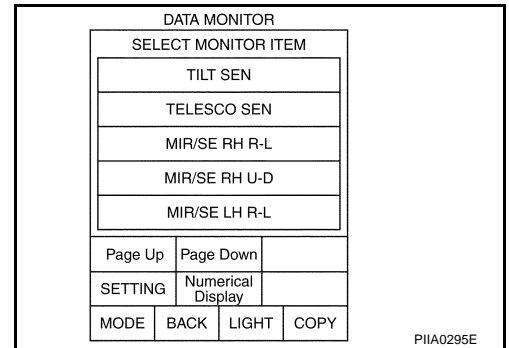

#### Without CONSULT-II

1. Turn ignition switch OFF.
2. Check voltage between automatic drive positioner control unit connector and ground.

Automatic drive positioner connector	Terminals		Condition	Voltage (V) (Approx.)
	(+)	(-)		
M6	23	Ground	Telescopic top position	4.6
			Telescopic bottom position	0.4

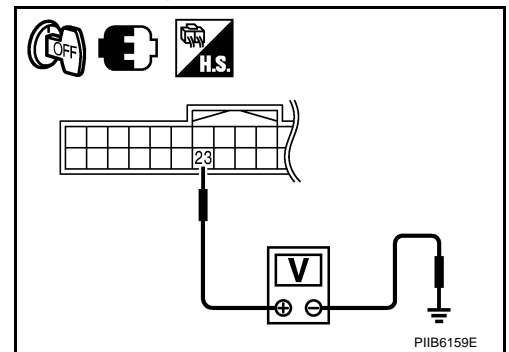

#### OK or NG

- OK >> Telescopic sensor circuit is OK.
- NG >> GO TO 2.

# AUTOMATIC DRIVE POSITIONER

## 2. CHECK HARNESS CONTINUITY

1. Disconnect automatic drive positioner control unit connector and telescopic sensor connector.
2. Check continuity harness between automatic drive positioner control unit connector and telescopic sensor connector.

A		B		Continuity
Automatic drive positioner control unit connector	Terminal	Telescopic sensor connector	Terminal	
M6	23	M44	2	Yes
M7	33		1	
	41		3	

3. Check continuity harness between automatic drive positioner control unit connector and ground.

A		Ground	Continuity
Automatic drive positioner control unit connector	Terminal		
M6	23	No	
M7	33		
	41		

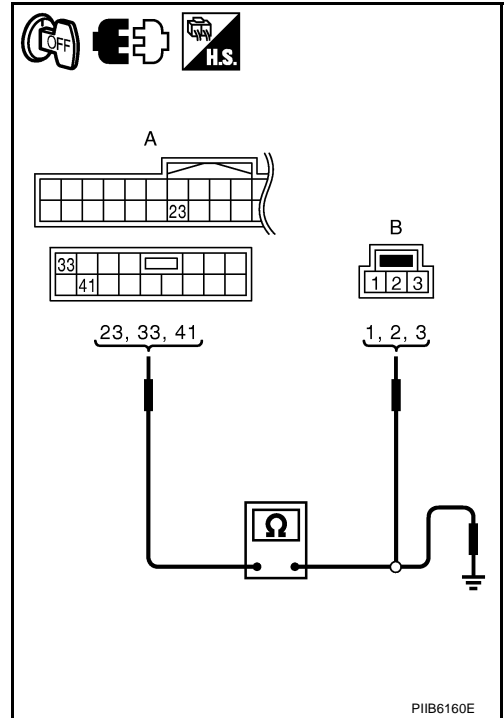

**OK or NG**

- OK >> GO TO 3.
- NG >> Repair or replace harness.

## 3. CHECK AUTOMATIC DRIVE POSITIONER CONTROL UNIT OUTPUT

1. Connect automatic drive positioner control unit connector.
2. Check voltage between automatic drive position control unit connector and ground.

Terminals			Voltage (V) (Approx.)
(+)		(-)	
Automatic drive positioner control unit connector	Terminal		
M6	23	Ground	5

**OK or NG**

- OK >> Replace telescopic sensor.
- NG >> Replace automatic drive positioner control unit.

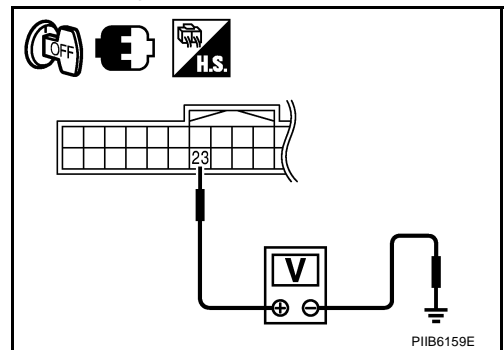

# AUTOMATIC DRIVE POSITIONER

NIS0026I

## Check Tilt Sensor Circuit

### 1. CHECK TILT SENSOR

#### With CONSULT-II

With "TILT SEN" on the DATA MONITOR, operate the tilt switch to make sure voltage changes.

Monitor item [OPERATION or UNIT]	Contents
TILT SEN	"V" The tilt position (voltage) judged from the tilt sensor signal is displayed.

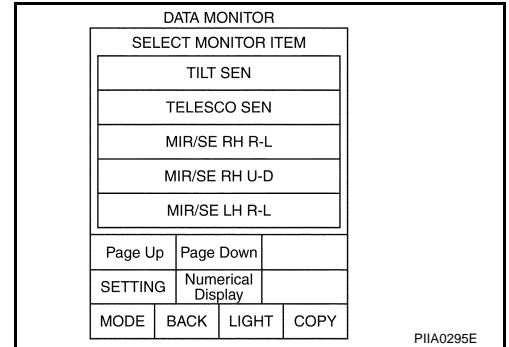

#### Without CONSULT-II

- Turn ignition switch OFF.
- Check voltage between automatic drive positioner control unit connector and ground.

Automatic drive positioner control unit connector	Terminals		Condition	Voltage (V) (Approx.)
	(+)	(-)		
M6	7	Ground	Tilt top position	1
			Tilt bottom position	3.8

#### OK or NG

- OK >> Tilt sensor circuit is OK.  
 NG >> GO TO 2.

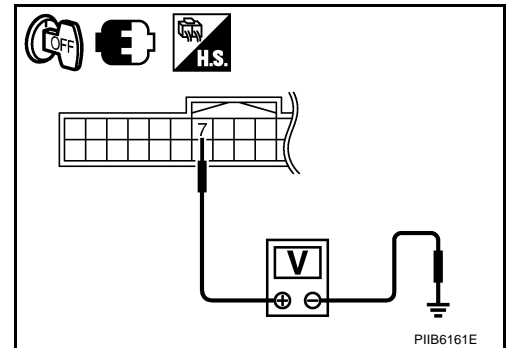

A  
B  
C  
D  
E  
F  
G  
H  
SE  
J  
K  
L  
M

# AUTOMATIC DRIVE POSITIONER

## 2. CHECK HARNESS

1. Disconnect automatic drive positioner control unit connector and tilt sensor connector.
2. Check continuity harness between automatic drive positioner control unit connector and tilt sensor connector.

A		B		Continuity
Automatic drive positioner control unit connector	Terminal	Tilt sensor connector	Terminal	
M6	7	M37	2	Yes
M7	33		3	
	41		1	

3. Automatic drive positioner control unit connector and ground.

A		Ground	Continuity
Automatic drive positioner control unit connector	Terminal		
M6	7	Ground	No
M7	33		
	41		

OK or NG

- OK >> GO TO 3.
- NG >> Repair or replace harness.

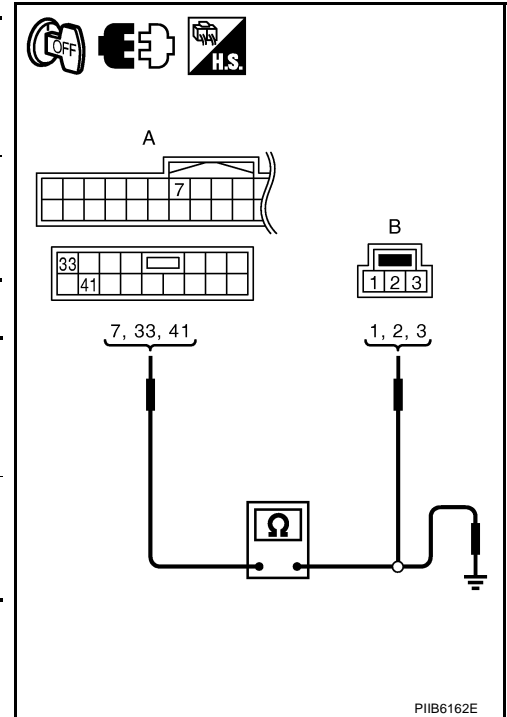

## 3. CHECK AUTOMATIC DRIVE POSITIONER CONTROL UNIT OUTPUT

1. Connect automatic drive positioner control unit connector.
2. Check voltage between automatic drive position control unit connector and ground.

Terminals			Voltage (V) (Approx.)
(+)		(-)	
Automatic drive positioner control unit connector	Terminal		
M6	7	Ground	5

OK or NG

- OK >> Replace telescopic sensor.
- NG >> Replace automatic drive positioner control unit.

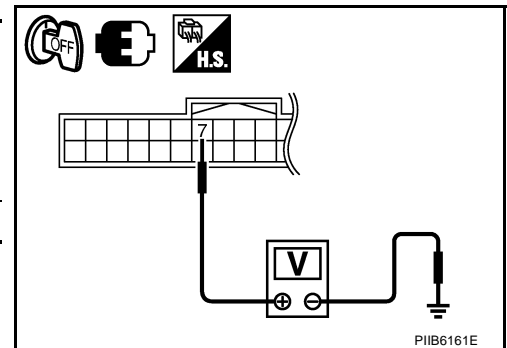

## Check Door Mirror Sensor LH Circuit

### 1. CHECK DOOR MIRROR FUNCTION

Check the following items.  
Operation malfunction in memory operation.

**NOTE:**

If a door mirror face position is set to an implausible angle, the set position may not be reproduced.

OK or NG

- OK >> GO TO 2.
- NG >> Repair or replace the malfunctioning parts, and check the symptom again.

NIS0026J



# AUTOMATIC DRIVE POSITIONER

## 2. CHECK DOOR MIRROR LH SENSOR

### With CONSULT-II

Check that "VOLTAGE" is displayed on "MIR/SE LH R-L, MIR/SE LH U-D" in the DATA MONITOR.

Monitor item [OPERATION or UNIT]		Contents
MIR/ SEN LH R-L	"V"	Voltage output from door mirror LH sensor (LH/ RH) is displayed.
MIR/ SEN LH U-D	"V"	Voltage output from door mirror LH sensor (UP/ DOWN) is displayed.

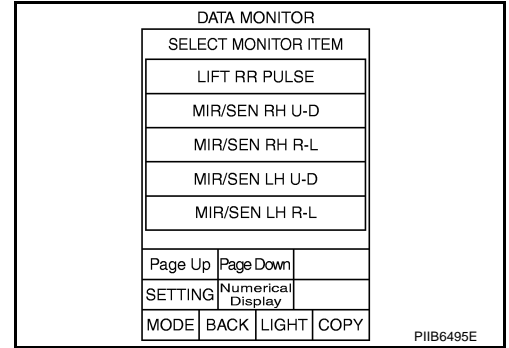

### Without CONSULT-II

1. Turn ignition switch to ACC.
2. Check voltage between automatic drive positioner control unit connector and ground.

Automatic drive positioner control unit connector	Terminals		Condition	Voltage (V) (Approx.)
	(+)	(-)		
M6	22	Ground	Mirror motor is operated LEFT or RIGHT	Changes between 3.5 (close to right edge) – 0.5 (close to left edge)
	6		Mirror motor is operated UP or DOWN	Changes between 4.2 (close to peak) – 0.5 (close to valley)

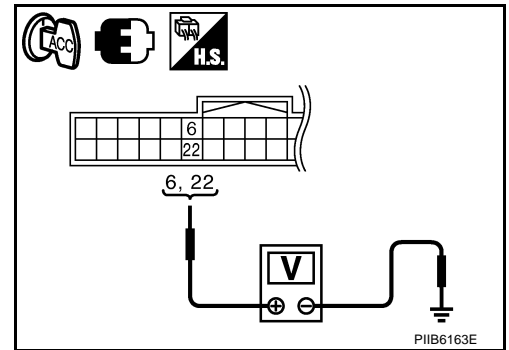

### OK or NG

- OK >> Mirror sensor LH circuit is OK.  
 NG >> GO TO 3.

# AUTOMATIC DRIVE POSITIONER

## 3. CHECK HARNESS CONTINUITY 1

1. Turn ignition switch OFF.
2. Disconnect automatic drive positioner control unit connector and door mirror LH connector.
3. Check continuity between automatic drive positioner control unit connector and door mirror LH connector.

A		B		Continuity
Automatic drive positioner control unit connector	Terminal	Door mirror LH connector	Terminal	
M7	33	D2	11	Yes
	41		12	

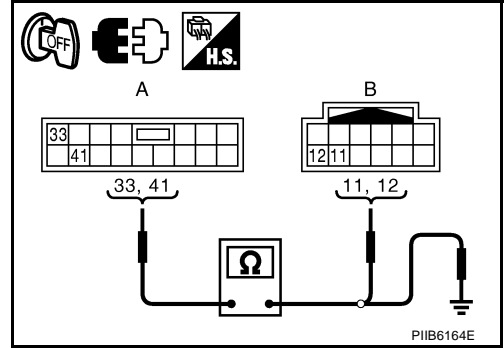

4. Check continuity between automatic drive positioner control unit connector and ground.

A		Ground	Continuity
Automatic drive positioner control unit connector	Terminal		
M7	33		No
	41		

OK or NG

- OK >> GO TO 4.  
 NG >> Repair or replace harness.

## 4. CHECK HARNESS CONTINUITY 2

1. Check continuity between automatic drive positioner control unit connector and door mirror LH connector.

A		B		Continuity
Automatic drive positioner control unit connector	Terminal	Door mirror LH connector	Terminal	
M6	6	D2	9	Yes
	22		10	

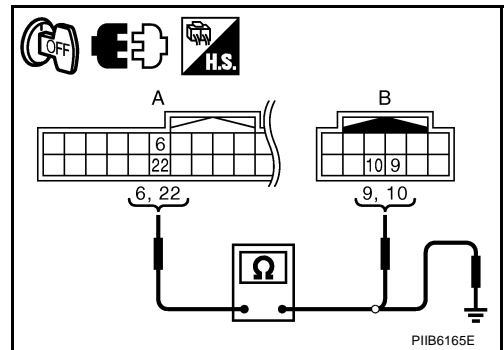

2. Check continuity between automatic drive positioner control unit connector and ground.

A		Ground	Continuity
Automatic drive positioner control unit connector	Terminal		
M6	6		No
	22		

OK or NG

- OK >> Replace door mirror LH.  
 NG >> Repair or replace harness.

# AUTOMATIC DRIVE POSITIONER

NIS0026K

## Check Door Mirror Sensor RH Circuit

### 1. CHECK DOOR MIRROR FUNCTION

Check the following items.  
Operation malfunction in memory operation.

**NOTE:**

If a door mirror face position is set to an implausible angle, the set position may not be reproduced.

OK or NG

OK >> GO TO 2.

NG >> Repair or replace the malfunctioning parts, and check the symptom again.

### 2. CHECK DOOR MIRROR RH SENSOR

**With CONSULT-II**

Check that "VOLTAGE" is displayed on "MIR/SE RH R-L, MIR/SE RH U-D" in the DATA MONITOR.

Monitor item [OPERATION or UNIT]		Contents
MIR/ SEN RH R-L	"V"	Voltage output from door mirror RH sensor (LH/ RH) is displayed.
MIR/ SEN RH U-D	"V"	Voltage output from door mirror RH sensor (UP/ DOWN) is displayed.

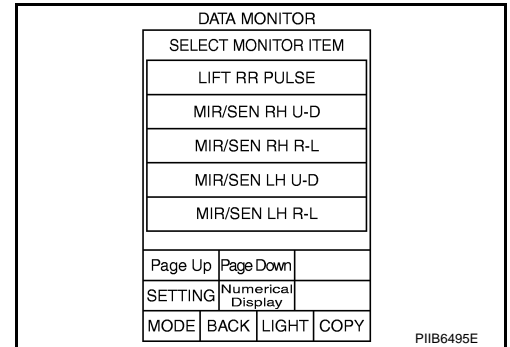

**Without CONSULT-II**

- Turn ignition switch to ACC.
- Check voltage between automatic drive positioner control unit connector and ground.

Automatic drive positioner control unit	Terminals		Condition	Voltage (V) (Approx.)
	(+)	(-)		
M6	21	Ground	Mirror motor is operated UP or DOWN	Changes between 3.5 (close to left edge) – 0.5 (close to right edge)
	5		Mirror motor is operated UP or DOWN	Changes between 4.2 (close to peak) – 0.5 (close to valley)

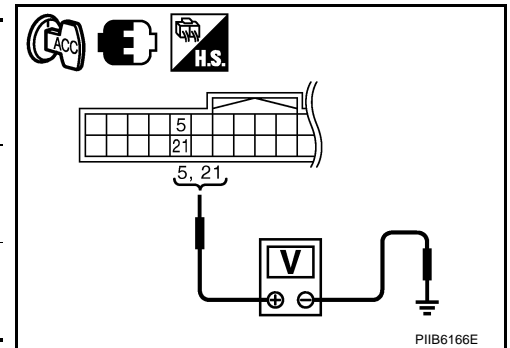

OK or NG

OK >> Mirror sensor RH circuit is OK.

NG >> GO TO 3.

# AUTOMATIC DRIVE POSITIONER

## 3. CHECK HARNESS CONTINUITY 1

1. Turn ignition switch OFF.
2. Disconnect automatic drive positioner control unit connector and door mirror RH connector.
3. Check continuity between automatic drive positioner control unit connector and door mirror RH connector.

A		B		Continuity
Automatic drive positioner control unit connector	Terminal	Door mirror RH connector	Terminal	
M7	33	D39	11	Yes
	41		12	

4. Check continuity between automatic drive positioner control unit connector and ground.

A		Ground	Continuity
Automatic drive positioner control unit connector	Terminal		
M7	33		No
	41		

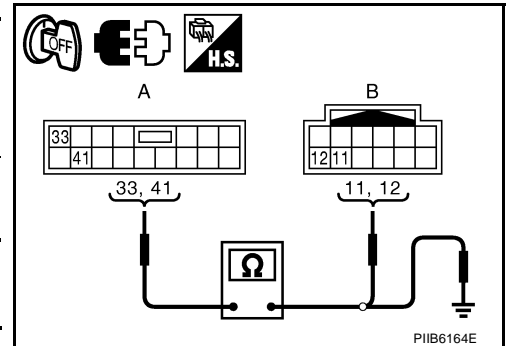

OK or NG

- OK >> GO TO 4.  
 NG >> Repair or replace harness.

## 4. CHECK HARNESS CONTINUITY 2

1. Check continuity between automatic drive positioner control unit connector and door mirror RH connector.

A		B		Continuity
Automatic drive positioner control unit connector	Terminal	Door mirror RH connector	Terminal	
M6	5	D39	9	Yes
	21		10	

2. Check continuity between automatic drive positioner control unit connector and ground.

A		Ground	Continuity
Automatic drive positioner control unit connector	Terminal		
M6	5		No
	21		

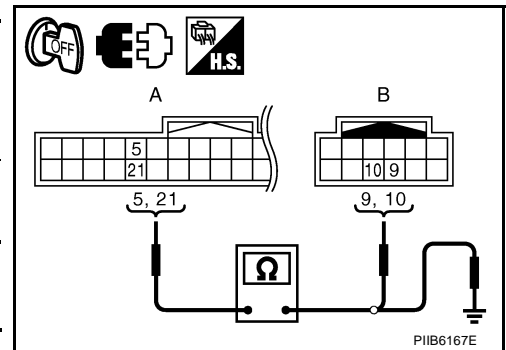

OK or NG

- OK >> Replace door mirror RH.  
 NG >> Repair or replace harness.

# AUTOMATIC DRIVE POSITIONER

NIS0026L

## Check Sliding Switch Circuit

### 1. CHECK FUNCTION

#### With CONSULT-II

With "SLIDE SW-FR, SLIDE SW-RR" on the DATA MONITOR, operate the sliding switch to check ON/OFF operation.

Monitor item [OPERATION or UNIT]		Contents
SLIDE SW-FR	"ON/OFF"	ON / OFF status judged from the sliding switch (FR) signal is displayed.
SLIDE SW-RR	"ON/OFF"	ON / OFF status judged from the sliding switch (RR) signal is displayed.

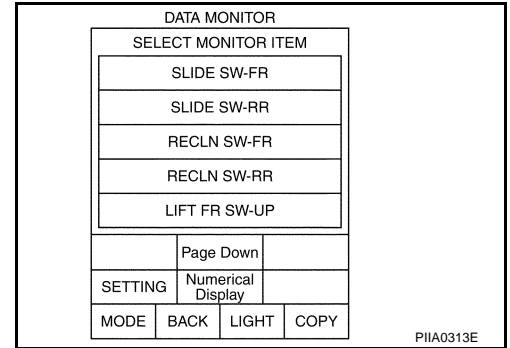

#### Without CONSULT-II

1. Turn ignition switch OFF.
2. Check voltage between driver seat control unit connector and ground.

Driver seat control unit connector	Terminal		Condition	Voltage (V) (Approx.)
	(+)	(-)		
B204	11	Ground	Sliding switch ON (BACKWARD operation)	0
			Other than above	Battery voltage
	26		Sliding switch ON (FORWARD operation)	0
			Other than above	Battery voltage

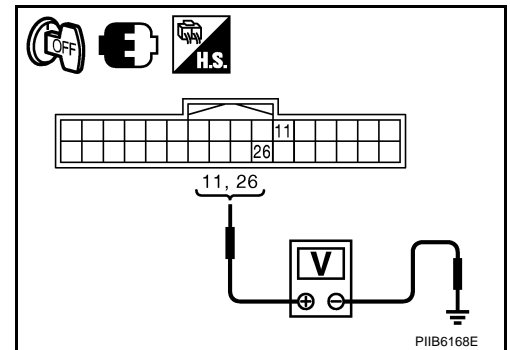

#### OK or NG

- OK >> Sliding switch circuit is OK.  
 NG >> GO TO 2.

# AUTOMATIC DRIVE POSITIONER

## 2. CHECK SLIDING SWITCH CIRCUIT HARNESS CONTINUITY

1. Disconnect driver seat control unit connector and power seat switch connector.
2. Check continuity between driver seat control unit connector and power seat switch connector.

A		B		Continuity
Driver seat control unit connector	Terminal	Power seat switch connector	Terminal	
B204	11	B213	11	Yes
	26		26	

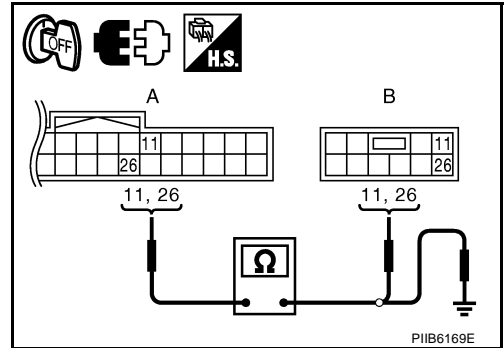

3. Check continuity between driver seat control unit connector and ground.

A		Ground	Continuity
Driver seat control unit connector	Terminal		
B204	11		No
	26		

**OK or NG**

- OK >> GO TO 3.
- NG >> Repair or replace harness.

## 3. CHECK SLIDING SWITCH

Check continuity between power seat switch terminals.

Power seat switch	Terminal		Condition	Continuity
B213	11	32	Sliding switch ON (BACKWARD operation)	Yes
			Other than above	No
	26	32	Sliding switch ON (FORWARD operation)	Yes
			Other than above	No

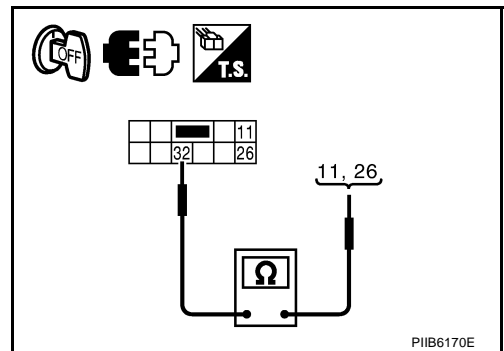

**OK or NG**

- OK >> Replace driver seat control unit.
- NG >> Replace power seat switch.

# AUTOMATIC DRIVE POSITIONER

NIS0026M

## Check Reclining Switch Circuit

### 1. CHECK FUNCTION

#### With CONSULT-II

With "RECLN SW-FR, RECLN SW-RR" on the DATA MONITOR, operate the reclining switch to check ON/OFF operation.

Monitor item [OPERATION or UNIT]		Contents
RECLN SW -FR	"ON/OFF"	ON/OFF status judged from the reclining switch (FR) signal is displayed.
RECLIN SW-RR	"ON/OFF"	ON/OFF status judged from the reclining switch (RR) signal is displayed.

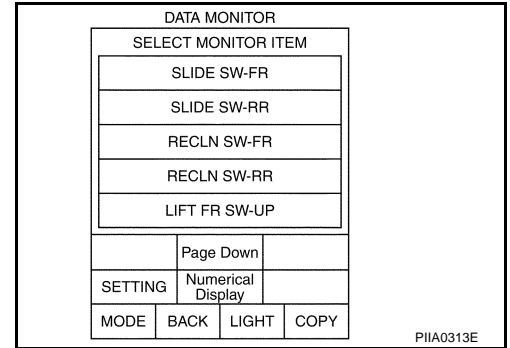

#### Without CONSULT-II

- Turn ignition switch OFF.
- Check voltage between driver seat control unit connector and ground.

Driver seat control unit	Terminals		Condition	Voltage (V) (Approx.)
	(+)	(-)		
B204	12	Ground	Reclining switch ON (BACKWARD operation)	0
			Other than above	Battery voltage
	27		Reclining switch ON (FORWARD operation)	0
			Other than above	Battery voltage

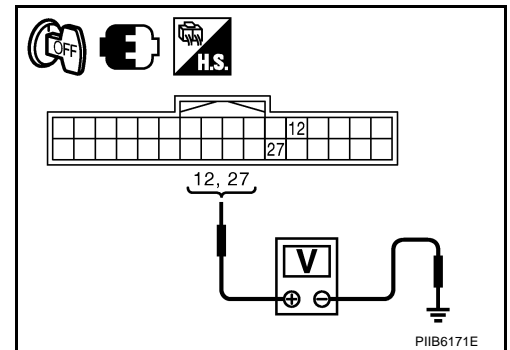

#### OK or NG

- OK >> Reclining switch circuit is OK.  
 NG >> GO TO 2.

# AUTOMATIC DRIVE POSITIONER

## 2. CHECK RECLINING SWITCH CIRCUIT HARNESS CONTINUITY

1. Disconnect driver seat control unit and power seat switch connector.
2. Check continuity between driver seat control unit connector and power seat switch connector.

A		B		Continuity
Driver seat control unit connector	Terminal	Power seat switch connector	Terminal	
B204	12	B213	12	Yes
	27		27	

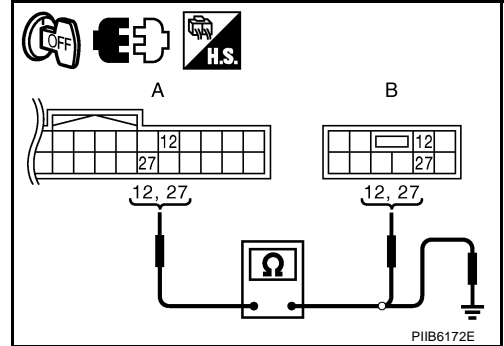

3. Check continuity between driver seat control unit connector and ground.

A		Ground	Continuity
Driver seat control unit connector	Terminal		
B204	12		No
	27		

**OK or NG**

- OK >> GO TO 3.
- NG >> Repair or replace harness.

## 3. CHECK RECLINING SWITCH

Check continuity between power seat switch as follows.

Power seat switch	Terminal		Condition	Continuity
B213	12	32	Reclining switch ON (BACKWARD operation)	Yes
			Other than above	No
	27	32	Reclining switch ON (FORWARD operation)	Yes
			Other than above	No

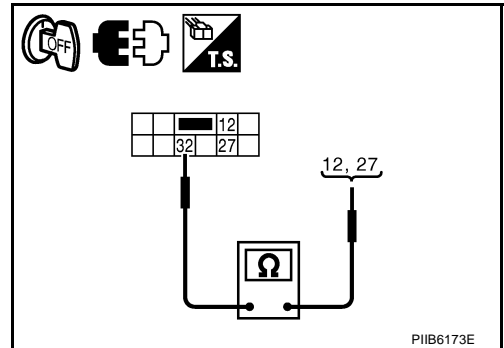

**OK or NG**

- OK >> Replace driver seat control unit.
- NG >> Replace power seat switch.



# AUTOMATIC DRIVE POSITIONER

## Check Lifting Switch (Front) Circuit

NIS0026N

### 1. CHECK FUNCTION

#### With CONSULT-II

With "LIFT FR SW-UP, LIFT FR SW-DN" on the DATA MONITOR, operate the lifting switch (front) to check ON/OFF operation.

Monitor item [OPERATION or UNIT]	Contents
LIFT FR SW-DN	"ON/OFF" ON / OFF status judged from the FR lifter switch (DOWN) signal is displayed.
LIFT FR SW-UP	"ON/OFF" ON / OFF status judged from the FR lifter switch (UP) signal is displayed.

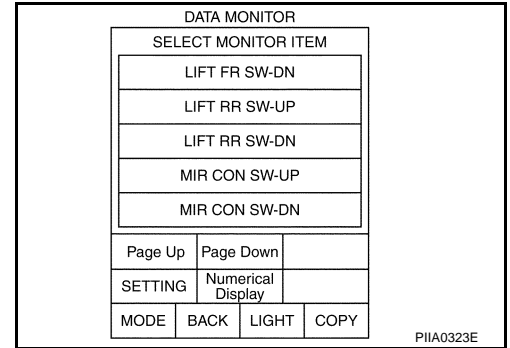

#### Without CONSULT-II

- Turn ignition switch OFF.
- Check voltage between driver seat control unit connector and ground.

Driver seat control unit connector	Terminals		Condition	Voltage (V) (Approx.)
	(+)	(-)		
B204	13	Ground	Lifting switch (front) ON (DOWN operation)	0
			Other than above	Battery voltage
	28		Lifting switch (front) ON (UP operation)	0
			Other than above	Battery voltage

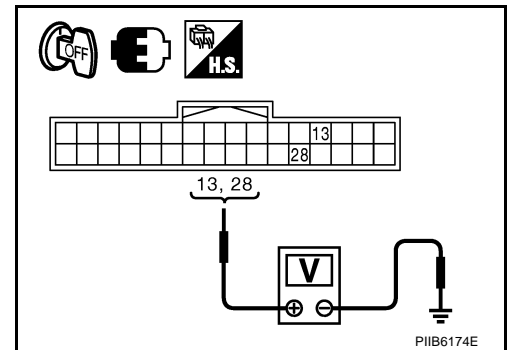

#### OK or NG

- OK >> Lifting switch (front) circuit is OK.  
 NG >> GO TO 2.

# AUTOMATIC DRIVE POSITIONER

## 2. CHECK LIFTING SWITCH (FRONT) CIRCUIT HARNESS CONTINUITY

1. Disconnect driver seat control unit and power seat switch connector.
2. Check continuity between driver seat control unit connector and power seat switch connector.

A		B		Continuity
Driver seat control unit connector	Terminal	Power seat switch connector	Terminal	
B204	13	B213	13	Yes
	28		28	

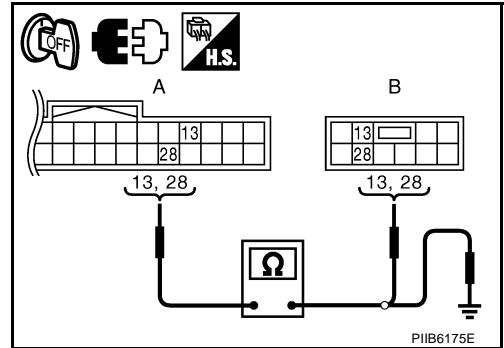

3. Check continuity between driver seat control unit connector and ground.

A		Ground	Continuity
Driver seat control unit connector	Terminal		
B204	13		No
	28		

**OK or NG**

- OK >> GO TO 3.
- NG >> Repair or replace harness.

## 3. CHECK LIFTING SWITCH (FRONT)

Check continuity between power seat switch as follows.

Power seat switch	Terminals		Condition	Continuity
B213	13	32	Lifting switch (front) ON (DOWN operation)	Yes
			Other than above	No
	28		Lifting switch (front) ON (UP operation)	Yes
			Other than above	No

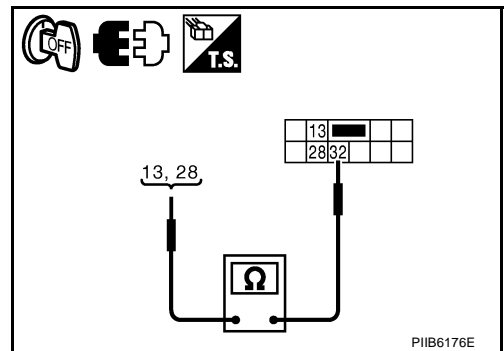

**OK or NG**

- OK >> Replace driver seat control unit.
- NG >> Replace power seat switch.

# AUTOMATIC DRIVE POSITIONER

NIS00260

## Check Lifting Switch (Rear) Circuit

### 1. CHECK FUNCTION

#### With CONSULT-II

With "LIFT RR SW-UP, LIFT RR SW-DN" on the DATA MONITOR, operate the lifting switch (rear) to check ON/OFF operation.

Monitor item [OPERATION or UNIT]		Contents
LIFT RR SW-UP	"ON/OFF"	Operation (ON)/open (OFF) status judged from the RR lifter switch (UP) signal is displayed.
LIFT RR SW-DN	"ON/OFF"	Operation (ON)/open (OFF) status judged from the RR lifter switch (DOWN) signal is displayed.

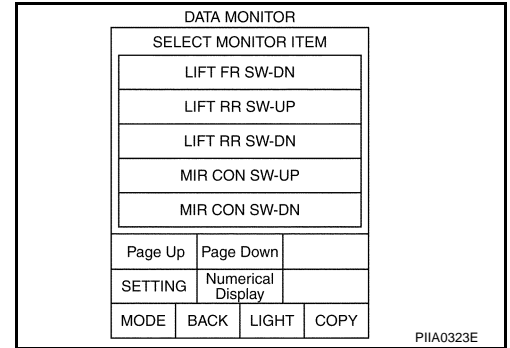

#### Without CONSULT-II

- Turn ignition switch OFF.
- Check voltage between driver seat control unit connector and ground.

Driver seat control unit connector	Terminals		Condition	Voltage (V) (Approx.)
	(+)	(-)		
B204	14	Ground	Lifting switch (rear) ON (DOWN operation)	0
			Other than above	Battery voltage
	29		Lifting switch (rear) ON (UP operation)	0
			Other than above	Battery voltage

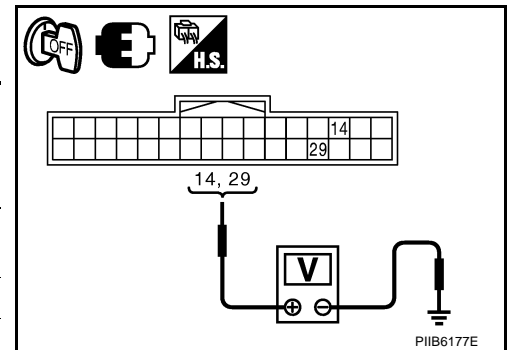

#### OK or NG

- OK >> Lifting switch (rear) circuit is OK.  
 NG >> GO TO 2.

A  
B  
C  
D  
E  
F  
G  
H  
SE  
J  
K  
L  
M

# AUTOMATIC DRIVE POSITIONER

## 2. CHECK LIFTING SWITCH (REAR) CIRCUIT HARNESS CONTINUITY

1. Disconnect driver seat control unit and power seat switch connector.
2. Check continuity between driver seat control unit connector and power seat switch connector.

A		B		Continuity
Driver seat control unit connector	Terminal	Power seat switch connector	Terminal	
B204	14	B213	14	Yes
	29		29	

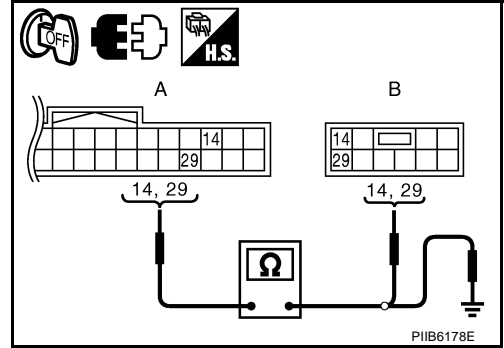

3. Check continuity between driver seat control unit connector and ground.

A		Ground	Continuity
Driver seat control unit connector	Terminal		
B204	14		No
	29		

**OK or NG**

- OK >> GO TO 3.
- NG >> Repair or replace harness.

## 3. CHECK LIFTING SWITCH (REAR)

Check continuity between power seat switch as follows.

Power seat switch	Terminals		Condition	Continuity
B213	14	32	Lifting switch (rear) ON (DOWN operation)	Yes
			Other than above	No
	29		Lifting switch (rear) ON (UP operation)	Yes
			Other than above	No

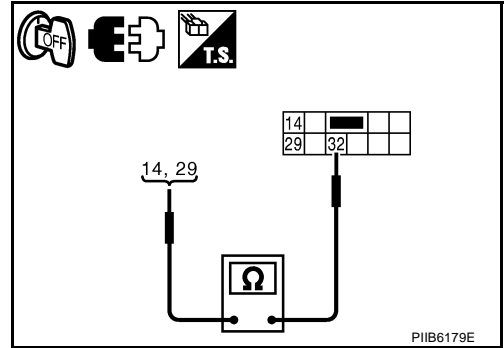

**OK or NG**

- OK >> Replace driver seat control unit.
- NG >> Replace power seat switch.

## Check Power Seat Switch Ground Circuit

NIS0026P

### 1. CHECK POWER SEAT SWITCH GROUND CIRCUIT

1. Turn ignition switch OFF.
2. Disconnect power seat switch connector.
3. Check continuity between power seat switch connector and ground.

Power seat switch connector	Terminal	Ground	Continuity
B213	32		Yes

**OK or NG**

- OK >> Replace driver seat control unit.
- NG >> Repair or replace harness.

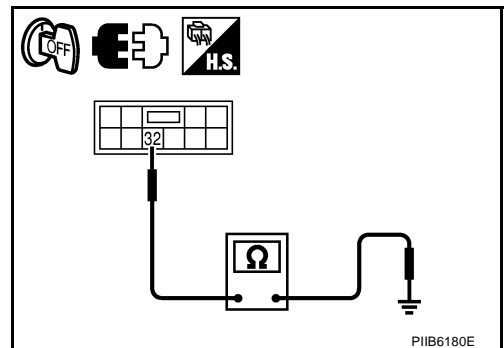

# AUTOMATIC DRIVE POSITIONER

## Check Telescopic Switch Circuit

NIS0026Q

### 1. CHECK FUNCTION

**With CONSULT-II**

With "TELESCO SW-FR, TELESCO SW-RR" on the DATA MONITOR, operate the ADP steering switch to check ON/OFF operation.

Monitor item [OPERATION or UNIT]		Contents
TELESCO SW-FR	"ON/OFF"	(ON/OFF) status judged from the telescoping switch (FR) signal is displayed.
TELESCO SW-RR	"ON/OFF"	(ON/OFF) status judged from the telescoping switch (RR) signal is displayed.

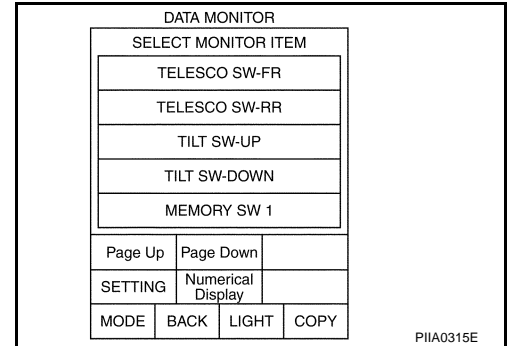

**Without CONSULT-II**

1. Turn ignition switch OFF.
2. Check voltage between automatic drive positioner control unit connector and ground.

Automatic drive positioner control unit connector	Terminals		Telescopic switch condition	Voltage (V) (Approx.)
	(+)	(-)		
M6	11	Ground	FORWARD	0
			Other than above	5
	27		BACKWARD	0
			Other than above	5

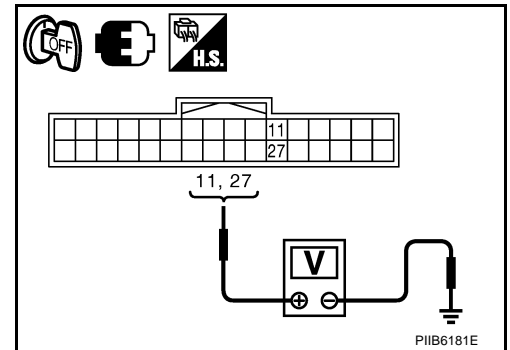

**OK or NG**

- OK >> Telescopic switch circuit is OK.  
 NG >> GO TO 2.

# AUTOMATIC DRIVE POSITIONER

## 2. CHECK TELESCOPIC CIRCUIT HARNESS CONTINUITY

1. Disconnect automatic drive positioner control unit connector and ADP steering switch connector.
2. Check continuity between automatic drive positioner control unit connector and ADP steering switch connector.

A		B		Continuity
Automatic drive positioner control unit connector	Terminal	ADP steering switch connector	Terminal	
M6	11	M46	5	Yes
	27		4	

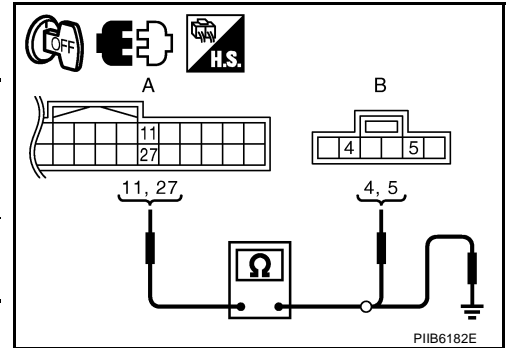

3. Check continuity between automatic drive positioner control unit connector and ground.

A		Ground	Continuity
Automatic drive positioner control unit connector	Terminal		
M6	11		No
	27		

**OK or NG**

- OK >> GO TO 3.
- NG >> Repair or replace harness.

## 3. CHECK TELESCOPIC SWITCH

ADP steering switch operate, check continuity ADP steering switch.

ADP steering switch	Terminal		ADP steering switch condition	Continuity
M46	5	1	FORWARD	Yes
			Other than above	No
	4		BACKWARD	Yes
			Other than above	No

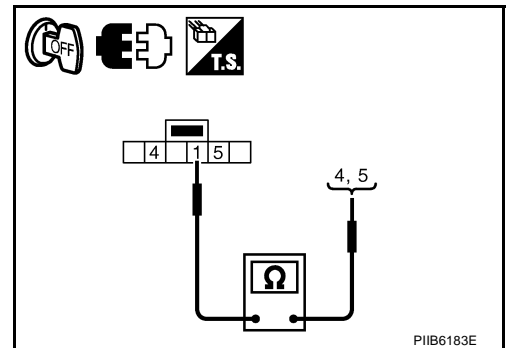

**OK or NG**

- OK >> GO TO 4.
- NG >> Replace ADP steering switch.

## 4. CHECK ADP STEERING SWITCH GROUND CIRCUIT

Check continuity between ADP steering switch connector and ground.

ADP steering switch connector	Terminal	Ground	Continuity
M46	1		Yes

**OK or NG**

- OK >> Replace automatic drive positioner control unit.
- NG >> Replace or replace harness.

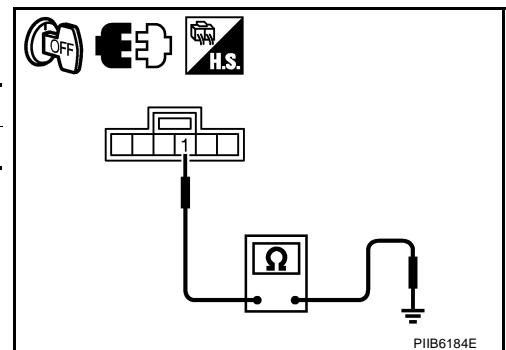

# AUTOMATIC DRIVE POSITIONER

NIS0026R

## Check Tilt Switch Circuit

### 1. CHECK FUNCTION

#### With CONSULT-II

With "TILT SW-UP,TILT SW-DOWN" on the DATA MONITOR, operate the ADP steering switch to check ON/OFF operation.

Monitor item [OPERATION or UNIT]		Contents
TILT SW-UP	"ON/OFF"	(ON/OFF) status judged from the tilt switch (UP) signal is displayed.
TILT SW-DOWN	"ON/OFF"	(ON/OFF) status judged from the tilt switch (DOWN) signal is displayed.

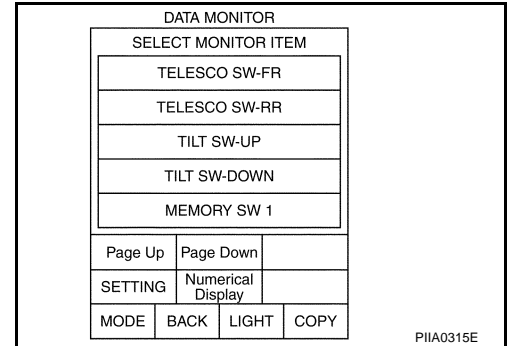

#### Without CONSULT-II

1. Turn ignition switch OFF.
2. Check voltage between automatic drive positioner control unit connector and ground.

Automatic drive positioner control unit connector	Terminals		Tilt switch condition	Voltage (V) (Approx.)
	(+)	(-)		
M6	1	Ground	UP	0
			Other than above	5
	17		DOWN	0
			Other than above	5

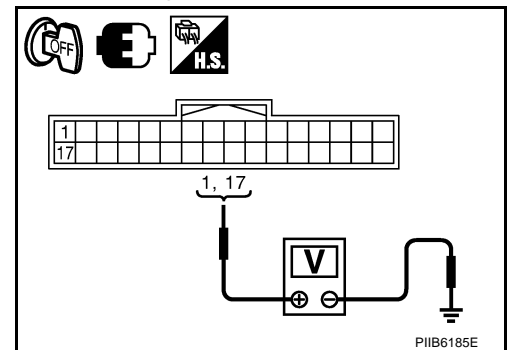

#### OK or NG

- OK >> Tilt switch circuit is OK.  
NG >> GO TO 2.

# AUTOMATIC DRIVE POSITIONER

## 2. CHECK TILT SWITCH CIRCUIT HARNESS CONTINUITY

1. Disconnect automatic drive positioner control unit connector and ADP steering switch connector.
2. Check continuity between automatic drive positioner control unit connector and ADP steering switch connector.

A		B		Continuity
Automatic drive positioner control unit connector	Terminal	ADP steering switch connector	Terminal	
M6	1	M46	2	Yes
	17		3	

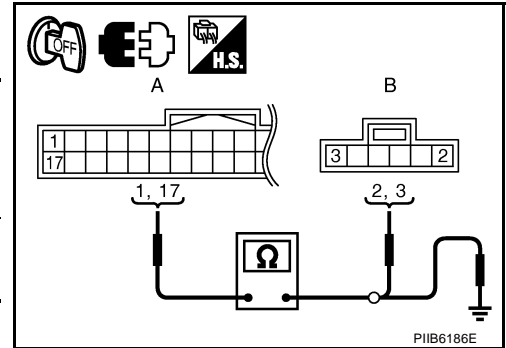

3. Check continuity between automatic drive positioner control unit connector and ground.

A		Ground	Continuity
Automatic drive positioner control unit connector	Terminal		
M6	1		No
	17		

**OK or NG**

- OK >> GO TO 3.
- NG >> Repair or replace harness.

## 3. CHECK ADP TILT STEERING SWITCH

ADP steering switch operate, check continuity ADP steering switch.

ADP steering switch	Terminal		ADP steering switch condition	Continuity
M46	2	1	UP	Yes
			Other than above	No
	3		DOWN	Yes
			Other than above	No

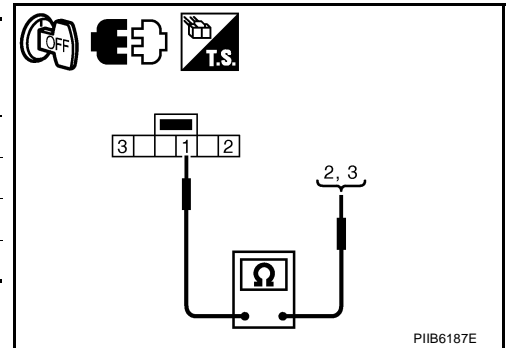

**OK or NG**

- OK >> GO TO 6.
- NG >> Replace ADP steering switch.

## 4. CHECK ADP STEERING SWITCH GROUND CIRCUIT

Check continuity between ADP steering switch connector and ground.

ADP steering switch connector	Terminal	Ground	Continuity
M46	1		Yes

**OK or NG**

- OK >> Replace automatic drive positioner control unit.
- NG >> Repair or replace harness.

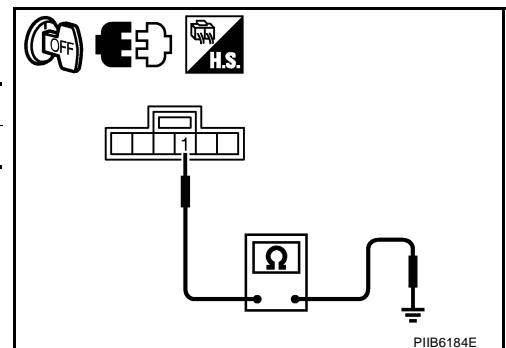



# AUTOMATIC DRIVE POSITIONER

NIS0026S

## Check Seat Memory and Set Switch Circuit

### 1. CHECK FUNCTION

#### With CONSULT-II

With "SET SW, MEMORY SW1, MEMORY SW2" on the DATA MONITOR, operate the switch to check ON/OFF operation.

Monitor item [OPERATION or UNIT]	Contents
SET SW	"ON/OFF" ON/OFF status judged from the setting switch signal is displayed.
MEMORY SW1	"ON/OFF" ON/OFF status judged from the seat memory switch 1 signal is displayed.
MEMORY SW2	"ON/OFF" ON/OFF status judged from the seat memory switch 2 signal is displayed.

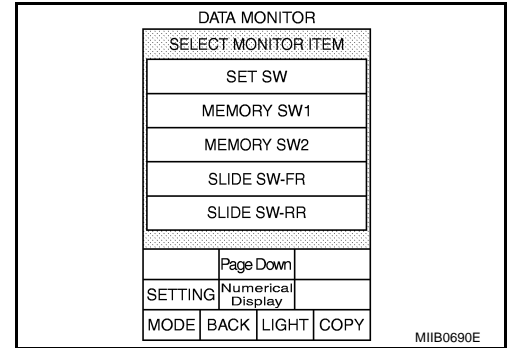

#### Without CONSULT-II

- Turn ignition switch OFF.
- Check voltage between automatic drive positioner control unit connector and ground.

Automatic drive positioner control unit connector	Terminals		Condition	Voltage [V] (Approx.)	
	(+)	(-)			
M6	9	Ground	Memory switch 1: ON	0	
			Other than above	5	
			Set switch: ON	0	
	24		Other than above	5	
			25	Memory switch 2: ON	0
				Other than above	5

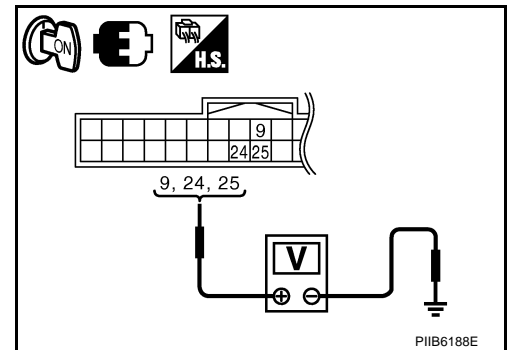

#### OK or NG

- OK >> Seat memory switch circuit is OK.  
 NG >> GO TO 2.

### 2. CHECK SEAT MEMORY SWITCH

- Disconnect seat memory switch connector.
- Operate the setting switch and seat memory switch.
- Check continuity between seat memory switch as follows.

Seat memory switch	Terminal	Condition	Continuity
D9	1	Memory switch 1 ON	Yes
		Memory switch 1: OFF	No
	2	Memory switch 2: ON	Yes
		Memory switch 2: OFF	No
	3	Set switch: ON	Yes
		Set switch: OFF	No

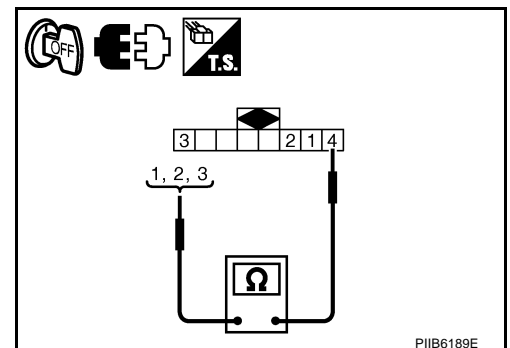

#### OK or NG

- OK >> GO TO 3.  
 NG >> Replace seat memory switch.

# AUTOMATIC DRIVE POSITIONER

## 3. CHECK HARNESS CONTINUITY

1. Disconnect automatic drive positioner control unit connector.
2. Check continuity between automatic drive positioner control unit connector and seat memory switch connector.

A		B		Continuity
Automatic drive positioner control unit connector	Terminal	Seat memory switch connector	Terminal	
M6	9	D9	1	Yes
	24		3	
	25		2	

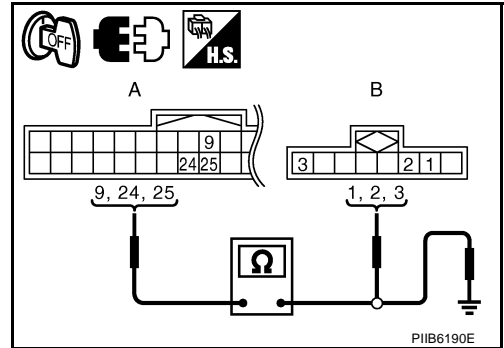

3. Check continuity between automatic drive positioner control unit connector and ground.

A		Ground	Continuity
Automatic drive positioner control unit connector	Terminal		
M6	9		No
	24		
	25		

### OK or NG

- OK >> GO TO 4.
- NG >> Repair or replace harness.

## 4. CHECK SEAT MEMORY SWITCH GROUND CIRCUIT

Check continuity between seat memory switch connector and ground.

Seat memory switch connector	Terminal	Ground	Continuity
D9	4		

### OK or NG

- OK >> Replace automatic drive positioner control unit.
- NG >> Repair or replace harness.

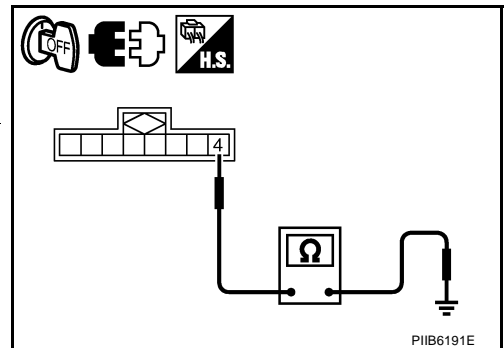

## Check Seat Memory Indicator Lamp Circuit

### 1. CHECK FUNCTION

#### With CONSULT-II

With "MEMORY SW INDCTR" in ACTIVE TEST, check operation.

Test item	Description
MEMORY SW INDCTR	The memory switch indicator is lit by receiving the drive signal.

### OK or NG

- OK >> Seat memory switch indicator lamp circuit is OK.
- NG >> GO TO 2.

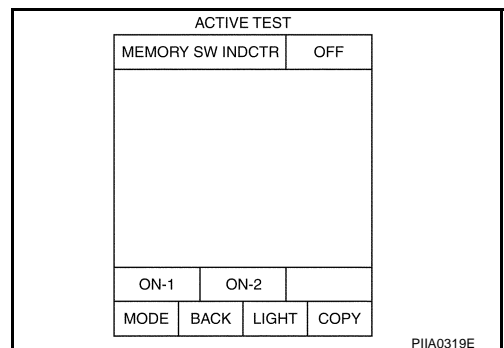

# AUTOMATIC DRIVE POSITIONER

## 2. CHECK SEAT MEMORY INDICATOR LAMP POWER SUPPLY CIRCUIT

1. Turn ignition switch OFF.
2. Disconnect seat memory switch connector.
3. Check voltage between seat memory switch connector and ground.

Terminals		Voltage (V) (Approx.)
(+)	(-)	
Seat memory switch connector	Terminal	
D9	5	Battery voltage

### OK or NG

OK >> GO TO 3.

NG >> Check the following.

- 10A fuse [No.18, Located in the fuse block (J/B)]
- Harness for open or short between seat memory switch and fuse.

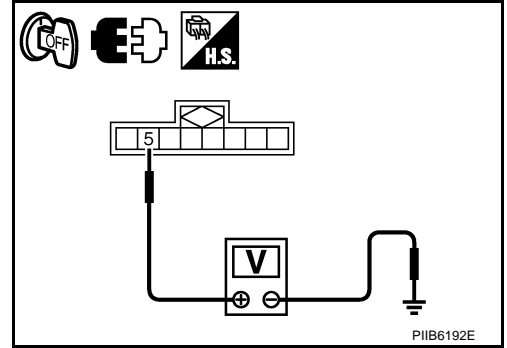

## 3. CHECK SEAT MEMORY INDICATOR CIRCUIT HARNESS CONTINUITY

1. Disconnect automatic drive positioner control unit connector.
2. Check continuity between automatic drive positioner control unit connector and seat memory switch connector.

A		B		Continuity
Automatic drive positioner control unit connector	Terminal	Seat memory switch connector	Terminal	
M6	12	D9	6	Yes
	13		7	

3. Check continuity between automatic drive positioner control unit connector and ground.

A		Ground	Continuity
Automatic drive positioner control unit connector	Terminal		
M6	12		No
	13		

### OK or NG

OK >> GO TO 4.

NG >> Repair or replace harness.

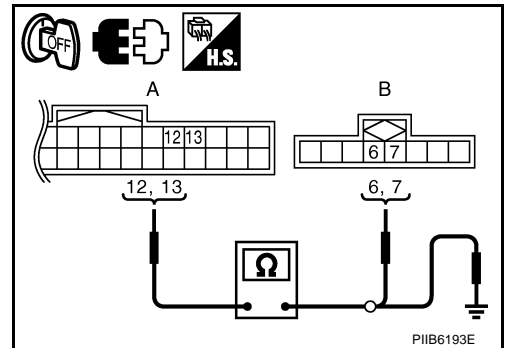

A  
B  
C  
D  
E  
F  
G  
H  
SE  
J  
K  
L  
M

# AUTOMATIC DRIVE POSITIONER

## 4. CHECK SEAT MEMORY SWITCH INDICATOR SIGNAL

1. Connect seat memory switch connector.
2. Check continuity between automatic drive positioner control unit connector and ground.

Terminals		Voltage (V) (Approx.)
(+)	(-)	
Seat memory switch connector	Terminal	Ground
M6	12	
	13	Battery voltage

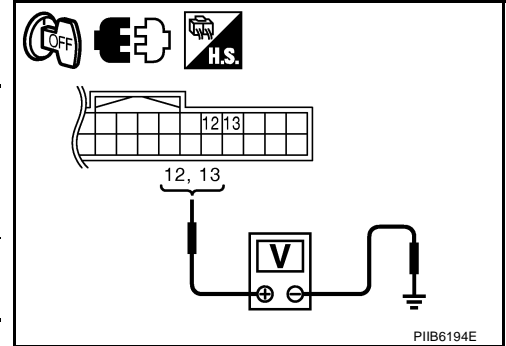

**OK or NG**

- OK >> Replace automatic drive positioner control unit.
- NG >> Replace seat memory switch.

## Check Door Mirror Sensor Power Supply and Ground Circuit

NIS0026U

### 1. CHECK DOOR MIRROR SENSOR CIRCUIT HARNESS CONTINUITY

1. Turn ignition switch OFF.
2. Disconnect automatic drive positioner control unit and door mirror (LH and RH) connector.
3. Check continuity between automatic drive positioner control unit connector and door mirror connector LH/RH.

A		B		Continuity
Automatic drive positioner control unit connector	Terminal	Door mirror connector	Terminal	
M7	33	D2 (LH)	11	Yes
	41	D39 (RH)	12	

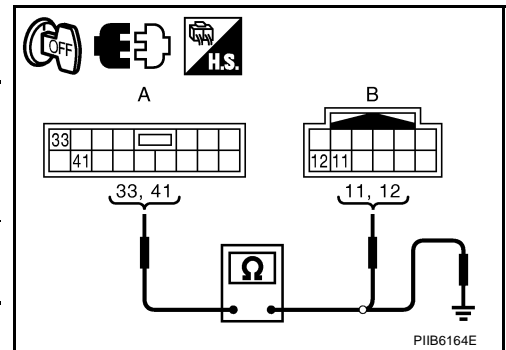

4. Check continuity between automatic drive positioner control unit connector and ground.

A		Ground	Continuity
Automatic drive positioner control unit connector	Terminal		
M7	33		No
	41		

**OK or NG**

- OK >> GO TO 2.
- NG >> Repair or replace harness.

# AUTOMATIC DRIVE POSITIONER

## 2. CHECK MIRROR SENSOR POWER SUPPLY

1. Connect automatic drive positioner control unit connector.
2. Turn ignition switch to ACC.
3. Check voltage between automatic drive positioner control unit connector and ground.

Terminals			Voltage (V) (Approx.)
(+)		(-)	
Automatic drive positioner control unit connector	Terminal	(-)	
M6	33	Ground	5

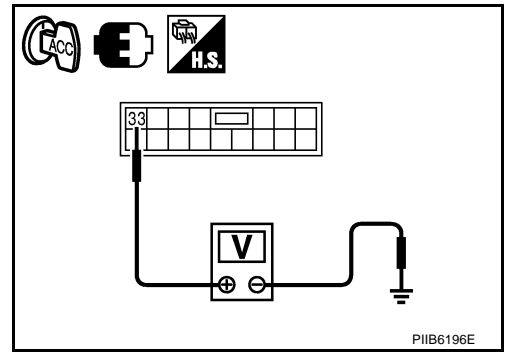

### OK or NG

- OK >> GO TO 3.  
 NG >> Replace automatic drive positioner control unit.

## 3. CHECK MIRROR SENSOR GROUND CIRCUIT

1. Turn ignition switch OFF.
2. Check continuity between automatic drive positioner control unit connector and ground.

Automatic drive positioner control unit connector	Terminal	Ground	Continuity
M6	41		Yes

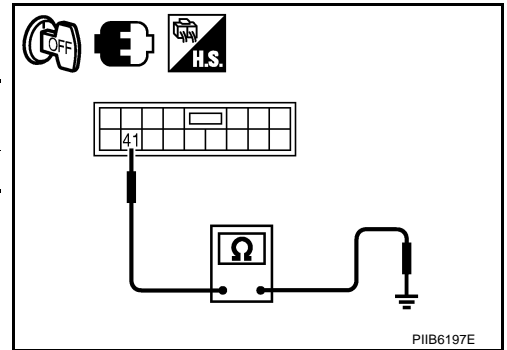

### OK or NG

- OK >> Door mirror power supply and ground circuit are OK.  
 NG >> Replace automatic drive positioner control unit.

A  
B  
C  
D  
E  
F  
G  
H  
SE  
J  
K  
L  
M

# AUTOMATIC DRIVE POSITIONER

NIS0026V

## Check A/T Device (Detention Switch) Circuit

### 1. CHECK FUNCTION

**With CONSULT-II**

Check that when the A/T selector lever is in P position, "DETENT SW" on the DATA MONITOR becomes OFF.

Monitor item [OPERATION or UNIT]	Contents	
Detention SW	"ON/ OFF"	The selector lever position "P position (OFF)/other than P position (ON)" judged from the detention switch signal is displayed.

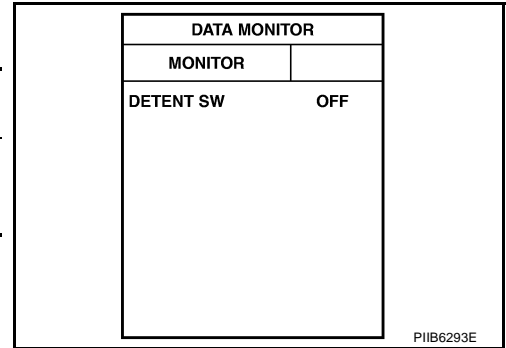

**Without CONSULT-II**

- Turn ignition switch OFF.
- Check voltage between driver seat control unit connector and ground.

Driver seat control unit connector	Terminal		Condition of A/T selector lever	Voltage (V) (Approx.)
	(+)	(-)		
M204	21	Ground	P position	0
			Other than above	Battery voltage

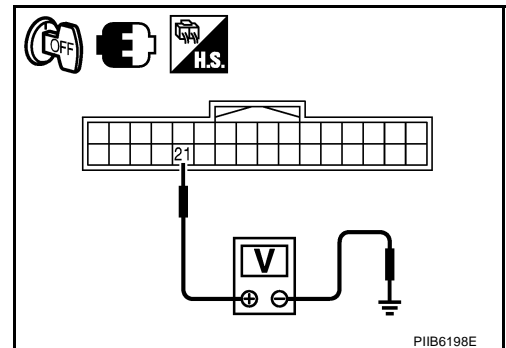

OK or NG

- OK >> A/T device (detention switch) circuit is OK.
- NG >> GO TO 2.

### 2. CHECK A/T DEVICE (PARK POSITION SWITCH) HARNESS

- Turn ignition switch OFF.
- Disconnect A/T device and driver seat control unit connector.
- Check continuity between A/T device connector and driver seat control unit connector.

A		B		Continuity
Driver seat control unit connector	Terminal	A/T device connector	Terminal	
M204	21	M133	10	Yes

- Check continuity between driver seat control unit connector and ground.

Driver seat control unit connector	Terminal	Ground	Continuity
M204	21		No

OK or NG

- OK >> GO TO 3.
- NG >> Repair or replace harness.

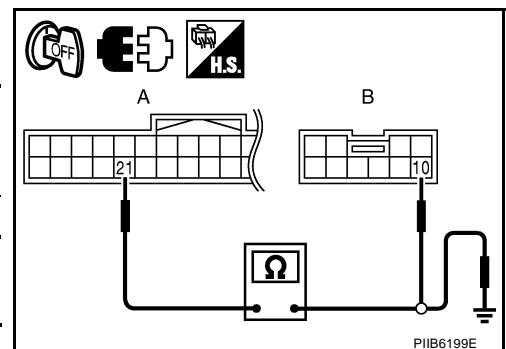

# AUTOMATIC DRIVE POSITIONER

## 3. CHECK PARK POSITION SWITCH

Check continuity between A/T device (detention switch) as follows.

A/T device	Terminals		Condition	Continuity
M133	9	10	P position	Yes
			Other than P position	No

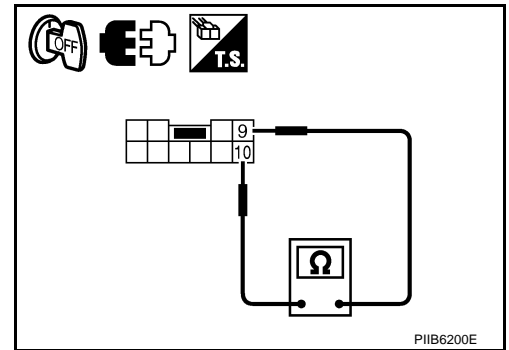

**OK or NG**

- OK >> Check the condition of the harness and the connector.
- NG >> Replace A/T device.

## Check Front Door Switch (Driver Side) Circuit

NIS0026W

### 1. CHECK DOOR SWITCH INPUT SIGNAL

1. Turn ignition switch OFF.
2. Check voltage between BCM connector and ground.

Terminals		Door condition	Voltage (V) (Approx.)
(+)			
BCM connector	Terminal		
M3	62	Driver side	0
			Battery voltage

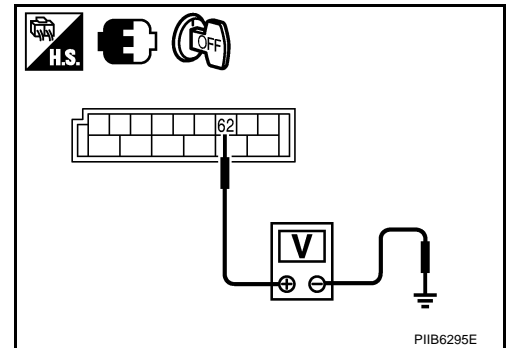

**OK or NG**

- OK >> Door switch circuit is OK.
- NG >> GO TO 2.

### 2. CHECK HARNESS CONTINUITY

1. Turn ignition switch OFF.
2. Disconnect BCM and door switch (driver side) connector.
3. Check continuity between BCM connector and door switch (driver side) connector.

A		B		Continuity
BCM connector	Terminal	Door switch connector	Terminal	
M3	62	B11	2	Yes

4. Check continuity between BCM connector ground.

A		Ground	Continuity
BCM connector	Terminal		
M3	62		No

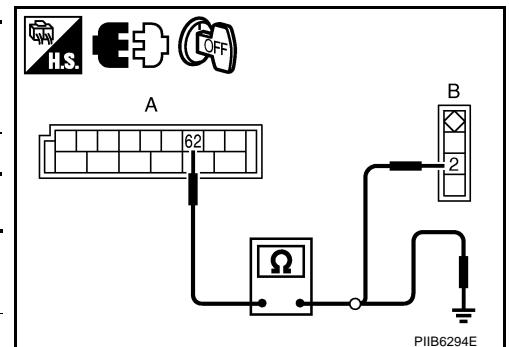

**OK or NG**

- OK >> GO TO 3.
- NG >> Repair or replace harness.

# AUTOMATIC DRIVE POSITIONER

## 3. CHECK DOOR SWITCH

Check continuity door switch (driver side).

Terminal		Door switch	Continuity
Door switch			
2	Ground part of door switch	Pushed	No
		Released	Yes

OK or NG

- OK >> GO TO 4.
- NG >> Replace door switch (driver side).

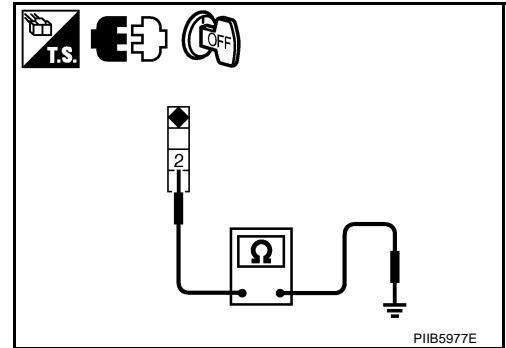

## 4. CHECK BCM OUTPUT SIGNAL

1. Connect BCM connector.
2. Check voltage between BCM connector ground.

Terminal		Voltage (V) (Approx.)
(+)	(-)	
BCM connector	Terminal	
M3	62	Ground
		Battery voltage

OK or NG

- OK >> Check the condition of the harness and the connector.
- NG >> Replace BCM.

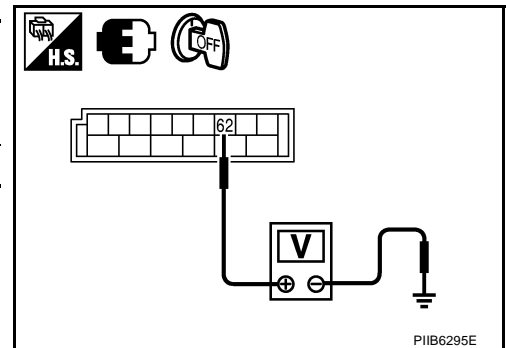

## Check UART Communication Line Circuit

### 1. CHECK UART LINE HARNESS

1. Turn ignition switch OFF.
2. Disconnect driver seat control unit and automatic drive positioner control unit connector.
3. Check continuity between driver seat control unit connector and automatic drive positioner connector.

A		B		Continuity
Driver seat control unit connector	Terminal	Automatic drive positioner control unit connector	Terminal	
B204	1	M6	10	Yes
	17		26	

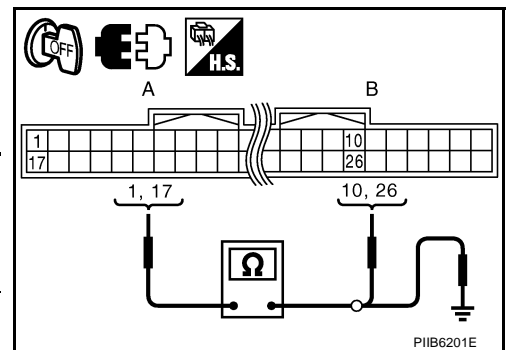

4. Check continuity between driver seat control unit connector and ground.

A		Ground	Continuity
Driver seat control unit connector	Terminal		
B204	1		No
	17		

OK or NG

- OK >> GO TO 2.
- NG >> Repair or replace harness.



# AUTOMATIC DRIVE POSITIONER

## 2. CHECK UART LINE INPUT/OUTPUT SIGNAL 1

1. Connect driver seat control unit and automatic drive positioner control unit connector.
2. Turn ignition switch ON.
3. Check signal between driver seat control unit connector and ground, with oscilloscope.

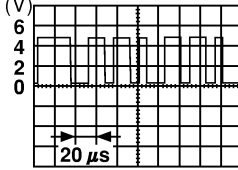
Driver seat control unit connector	Terminals		Condition	Signal (Reference value)
	(+)	(-)		
B204	17	Ground	Tilt switch operated	 <small>SKIA0175E</small>

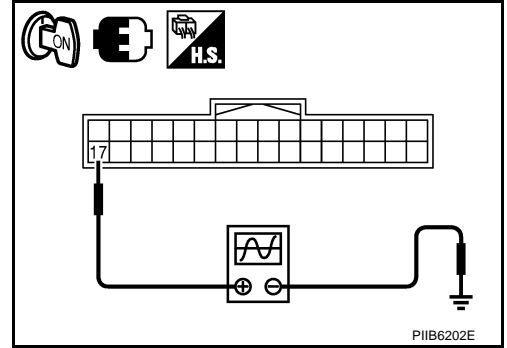

### OK or NG

OK >> GO TO 3.

NG >> Check the following.

- When voltage wave form does not appear with a constant voltage (approx. 5V), replace driver seat control unit.
- When voltage wave form does not appear with a constant voltage (approx. 0V), replace automatic drive positioner control unit.

## 3. CHECK UART LINE INPUT/OUTPUT SIGNAL 2

Check signal between automatic drive positioner control unit connector and ground, with oscilloscope.

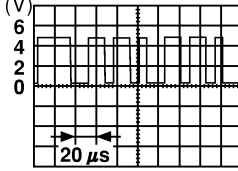
Automatic drive positioner control unit connector	Terminals		Condition	Signal (Reference value)
	(+)	(-)		
M6	10	Ground	Tilt switch operated.	 <small>SKIA0175E</small>

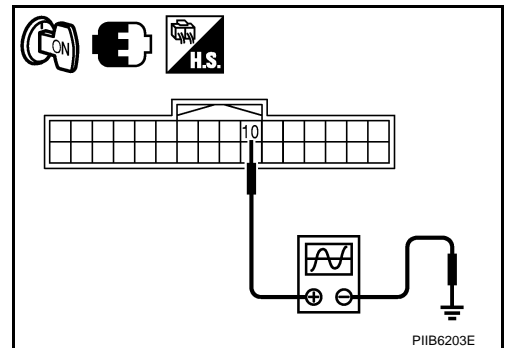

### OK or NG

OK >> GO TO 4.

NG >> Check the following.

- When voltage wave form does not appear with a constant voltage (approx. 5V), replace automatic drive positioner control unit.
- When voltage wave form does not appear with a constant voltage (approx. 0V), replace driver seat control unit.

## 4. CHECK DRIVER SEAT CONTROL UNIT

Does the automatic drive positioner operate when the driver seat control unit is exchanged?

# AUTOMATIC DRIVE POSITIONER

**OK or NG**

- OK >> Replace driver seat control unit.
- NG >> Replace automatic drive positioner control unit.

## Check Lumbar Support Circuit

NIS0026Y

### 1. CHECK LUMBAR SUPPORT SWITCH

1. Turn ignition switch OFF.
2. Disconnect lumbar support switch connector.
3. Check voltage between lumbar support switch connector and ground.

Terminals		Voltage (V) (Approx.)
(+)	(-)	
Lumbar support switch connector	Terminal	
B212	55	Ground
		Battery voltage

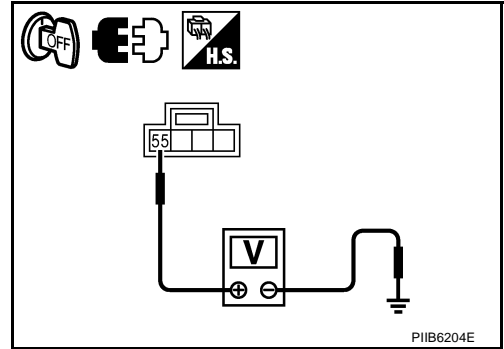

**OK or NG**

- OK >> GO TO 2.
- NG >> Repair or replace harness between fuse block (J/B) and lumbar support switch.

### 2. CHECK LUMBAR SUPPORT SWITCH

Check continuity lumbar support switch connector.

Lumbar support switch	Terminal		Condition of lumbar support switch	Continuity
B212	55	57	FORWARD	Yes
			Other than above	No
		58	BACKWARD	Yes
			Other than above	No
	56	57	FORWARD	No
			Other than above	Yes
58		BACKWARD	No	
		Other than above	Yes	

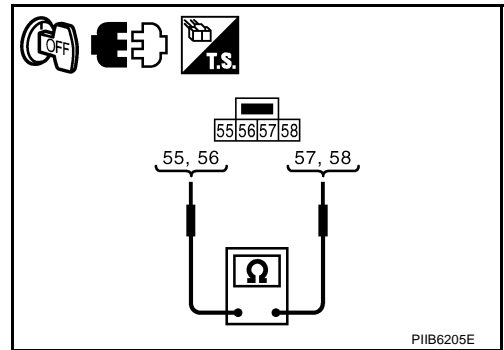

**OK or NG**

- OK >> GO TO 3.
- NG >> Replace lumbar support switch.

# AUTOMATIC DRIVE POSITIONER

## 3. CHECK LUMBAR SUPPORT MOTOR HARNESS

1. Disconnect lumbar support motor connector.
2. Check continuity between lumbar support switch connector and lumbar support motor connector.

A		B		Continuity
Lumbar support switch connector	Terminal	Lumbar support motor connector	Terminal	
B212	57	B211	57	Yes
	58		58	

3. Check continuity between lumbar support switch connector and ground.

A		Ground	Continuity
Lumbar support switch connector	Terminal		
B212	57		No
	58		

OK or NG

- OK >> GO TO 4.
- NG >> Repair or replace harness.

## 4. CHECK LUMBAR SUPPORT SWITCH GROUND CIRCUIT

Check continuity between lumbar support switch connector and ground.

Lumbar support switch connector	Terminal	Ground	Continuity
B212	56		Yes

OK or NG

- OK >> Check the condition of the harness and connector.
- NG >> Repair or replace harness between lumbar support switch and ground.

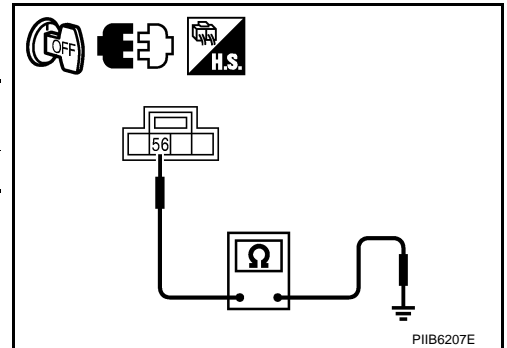
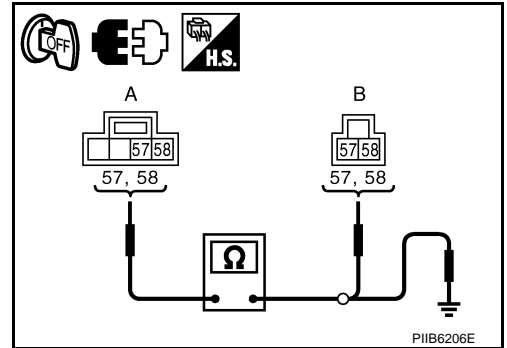

A  
B  
C  
D  
E  
F  
G  
H  
SE  
J  
K  
L  
M

# POWER SEAT(PASSENGER SIDE)

PFP:87050

NIS0028P

## POWER SEAT(PASSENGER SIDE) Schematic

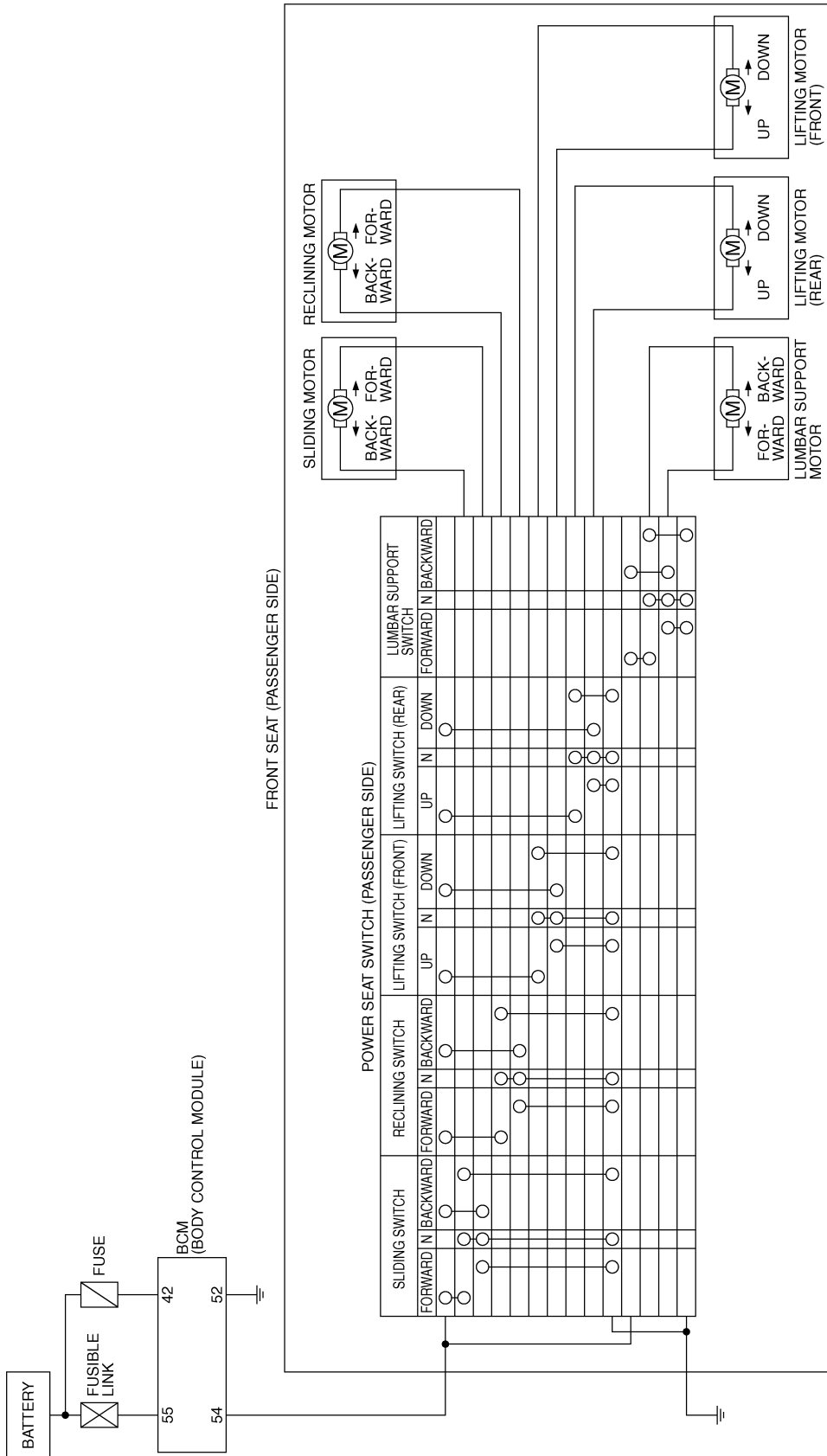

TIWT2055E



# POWER SEAT(PASSENGER SIDE)

SE-SEAT-02

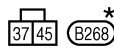
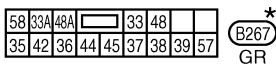
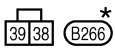
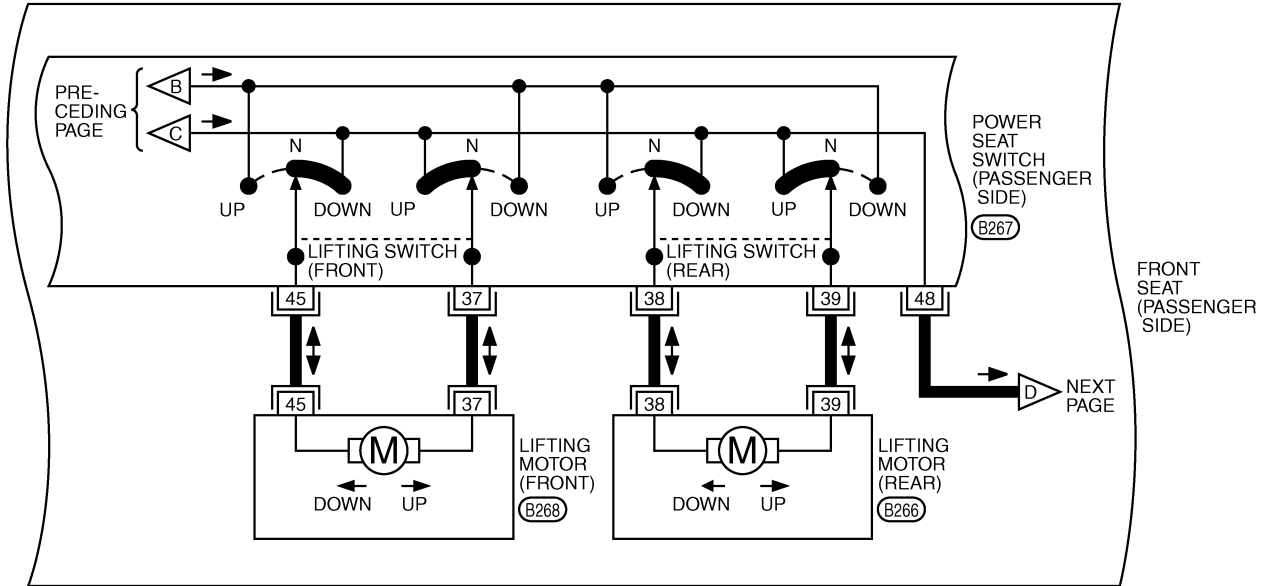

\*: THIS CONNECTOR IS NOT SHOWN IN "HARNES LAYOUT", PG SECTION.

TIWT2057E

# POWER SEAT(PASSENGER SIDE)

SE-SEAT-03

A  
B  
C  
D  
E  
F  
G  
H  
SE  
J  
K  
L  
M

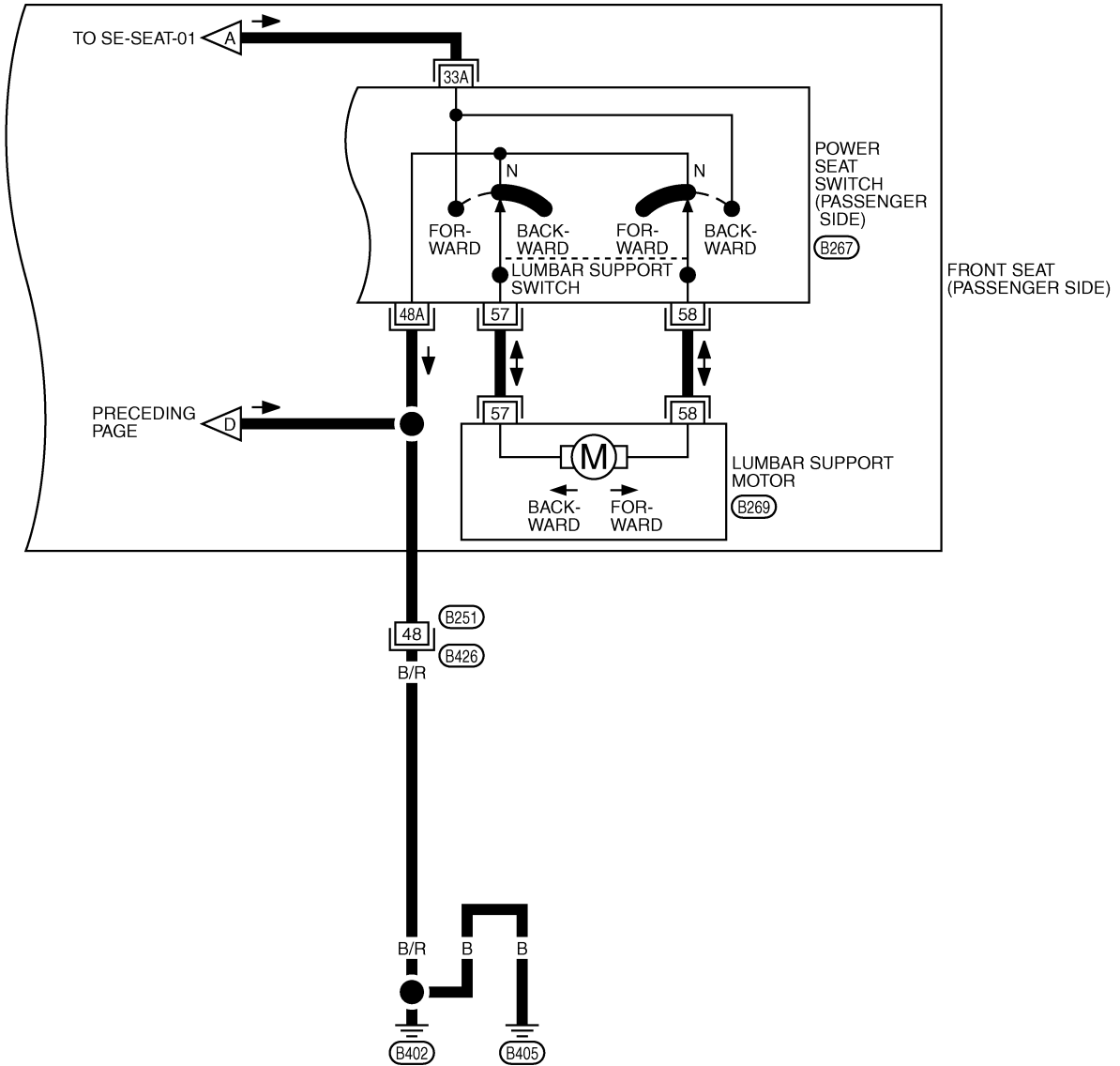

58	33A	48A		33	48	
35	42	36	44	45	37	38
				39	57	

\*  
B267  
GR

58	57
----	----

\*  
B269

80	55	54	7	61		60	59	53	52	51
16	58	4	57	5	48	6	33			

\*  
B426  
W

\*: THIS CONNECTOR IS NOT SHOWN IN "HARNES LAYOUT", PG SECTION.

TIWT2058E

# POWER SEAT(REAR)

PFP:88010

## POWER SEAT(REAR)

### Component Parts and Harness Connector Location

NIS00272

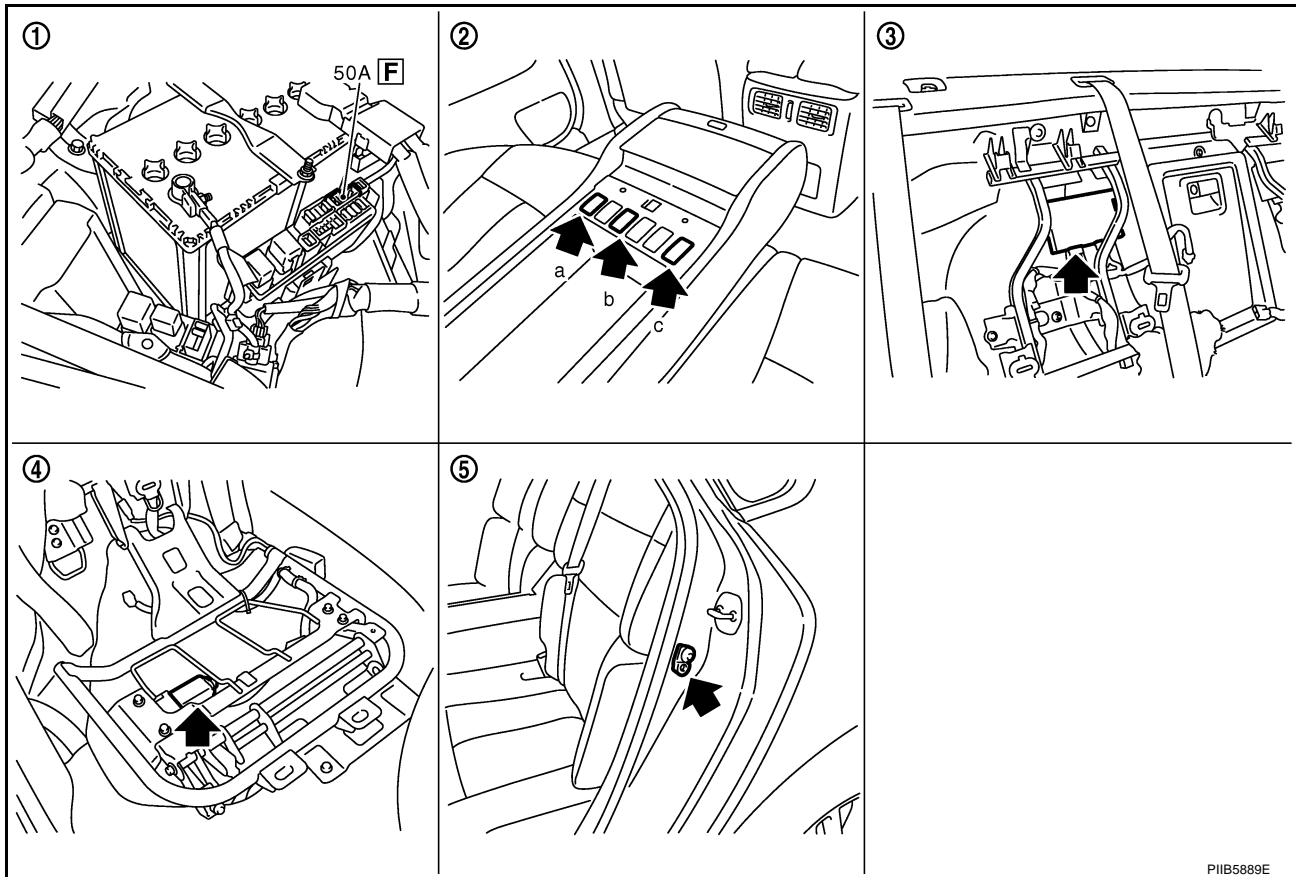

PIIB5889E

- |                                                                                           |                                                                                                                     |                                                                                                 |
|-------------------------------------------------------------------------------------------|---------------------------------------------------------------------------------------------------------------------|-------------------------------------------------------------------------------------------------|
| 1. Fuse, fusible link and relay block (J/B)                                               | 2. a: Rear power seat switch LH B504<br>b: Automatic return cancel switch B508<br>c: Rear power seat switch RH B555 | 3. Rear seat control unit B303, B304 (LH) B353, B354 (RH) (View with the rear seatback removed) |
| 4. Rear seat sliding motor B311 (LH), B361 (RH) (View with the rear seat cushion removed) | 5. Rear door switch B53 (LH), B403 (RH)                                                                             |                                                                                                 |

## System Description

NIS00273

The rear power seat (LH / RH) retreats when the auto return cancel switch is turned on and each door is opened.

When the rear power seat switch turned on, or auto return cancel switch is canceled, an auto return is discontinued.

Power is all time supplied

- through 50A fusible link [letter F, located in the fuse block (J/B)],
- to rear LH seat control unit, rear RH seat control unit terminal 1.

## REAR POWER SEAT LH AND RH OPERATION

When rear power seat switch is forward, ground is supplied

- to rear seat control unit terminal 10,
- through rear power seat switch terminal 2,
- through rear power seat switch terminal 3,
- through body grounds B5, B40, B131.

When rear seat control unit receives power seat switch forward signal, power is supplied

- through rear seat control unit terminal 2,
- to rear seat sliding motor terminal 3.



## POWER SEAT(REAR)

Then ground is supplied

- through rear seat sliding motor terminals 5,
- through body grounds B5, B40, B131.

A

When power and ground are supplied, rear power seat slide moves forward.

When rear power seat switch is backward, ground is supplied

B

- to rear seat control unit terminal 15,
- through rear power seat switch terminal 1,
- through rear power seat switch terminal 3,
- through body grounds B5, B40, B131.

C

When rear seat control unit receives power seat switch backward signal, power is supplied

D

- to rear seat control unit terminal 7,
- through rear seat sliding motor terminal 4.

Then ground is supplied

E

- through rear seat sliding motor terminals 5,
- through body grounds B5, B40, B131.

When power and ground are supplied, rear power seat slide moves backward.

F

### REAR SEAT RETREAT FUNCTION

When rear door open, ground is supplied

G

- to rear seat control unit terminal 16,
- through rear door switch terminal 2,

When rear seat control unit receives automatic return cancel switch ON and rear door switch open signal, power is supplied

H

- through rear seat control unit terminal 7,
- to rear seat sliding motor terminal 4.

SE

Then ground is supplied

- through rear seat sliding motor terminals 5,
- through body grounds B5, B40, B131.

J

When power and ground are supplied, rear power seat slide moves backward.

When rear seat sliding motor is operated, ground is supplied

K

- to rear seat control unit terminal 12,
- through rear seat sliding motor terminal 1,
- through rear seat sliding motor terminal 2,
- through rear seat control unit terminal 19,
- through rear seat control unit terminals 13,
- through body grounds B5, B40, B131.

L

M

Then rear seat control unit receives rear power seat sliding sensor signal.

The rear power seat control unit controls the seat position of the system operation with the signal.

# POWER SEAT(REAR)

## Schematic

NIS00274

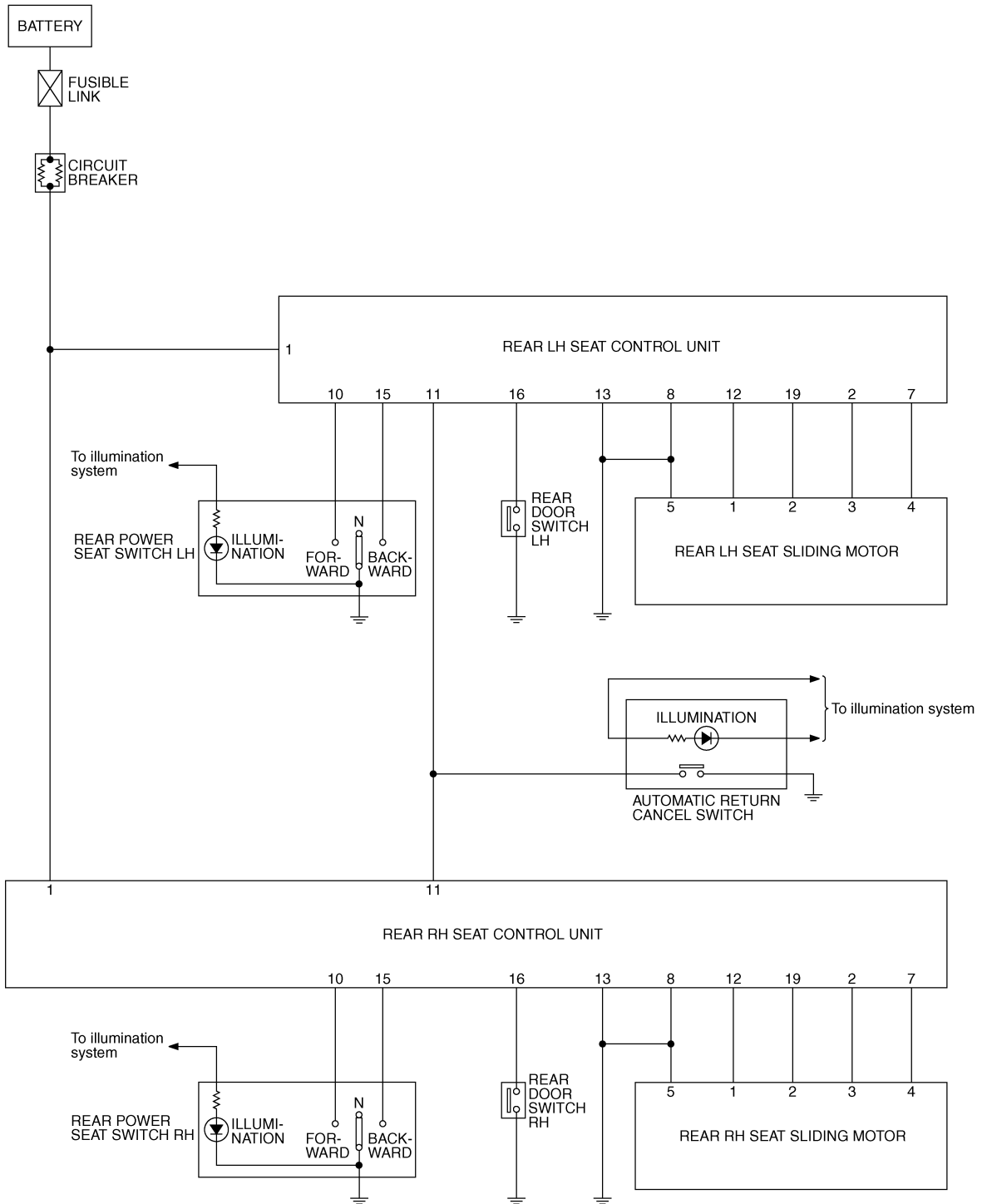

TIWT1386E

# POWER SEAT(REAR)

## Wiring Diagram — R/SEAT —

NIS00275

### SE-R/SEAT-01

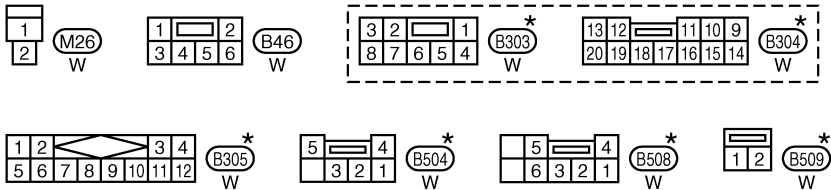
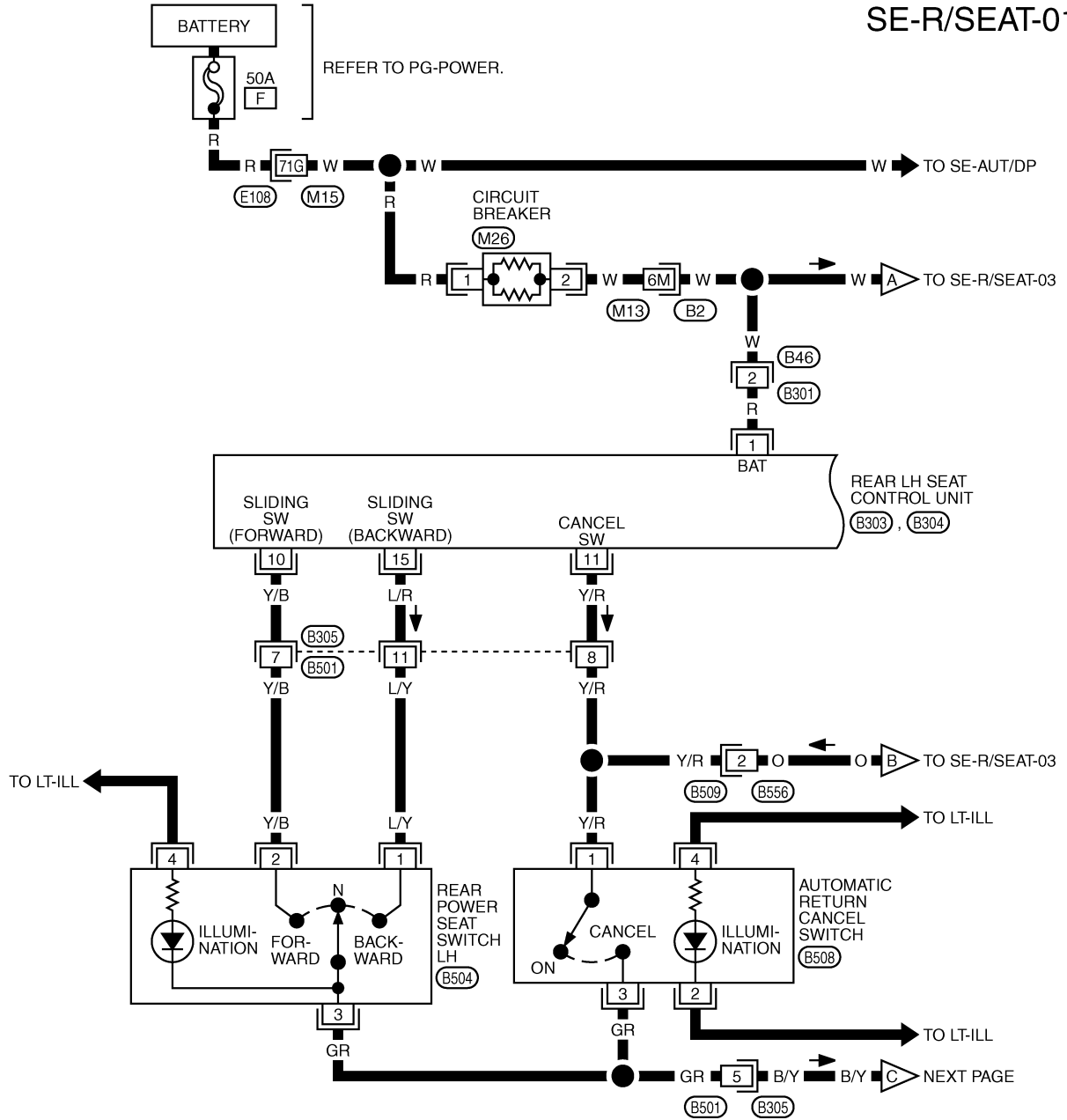

\*: THIS CONNECTOR IS NOT SHOWN IN "HARNESS LAYOUT", PG SECTION.

REFER TO THE FOLLOWING.  
 (E108), (B2) -SUPER MULTIPLE JUNCTION (SMJ)

TIWT1387E

# POWER SEAT(REAR)

SE-R/SEAT-02

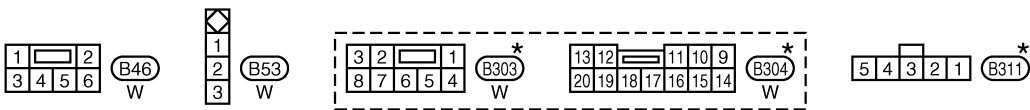
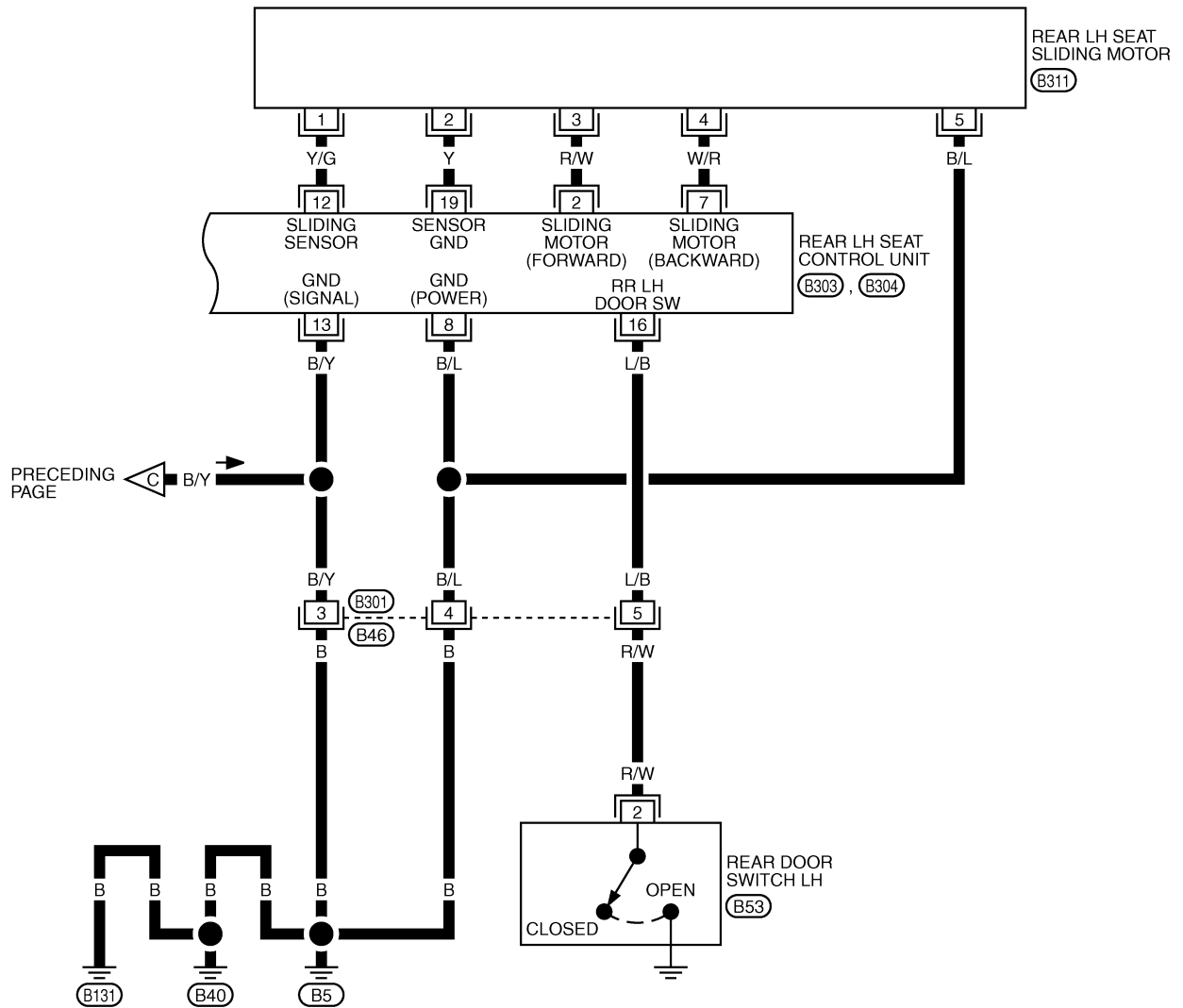

\*: THIS CONNECTOR IS NOT SHOWN IN "HARNESS LAYOUT", PG SECTION.

TIWT1388E

# POWER SEAT(REAR)

SE-R/SEAT-03

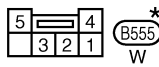
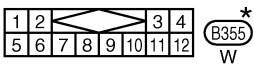
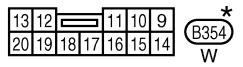
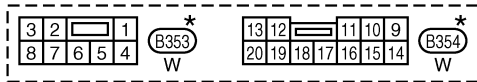
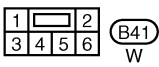
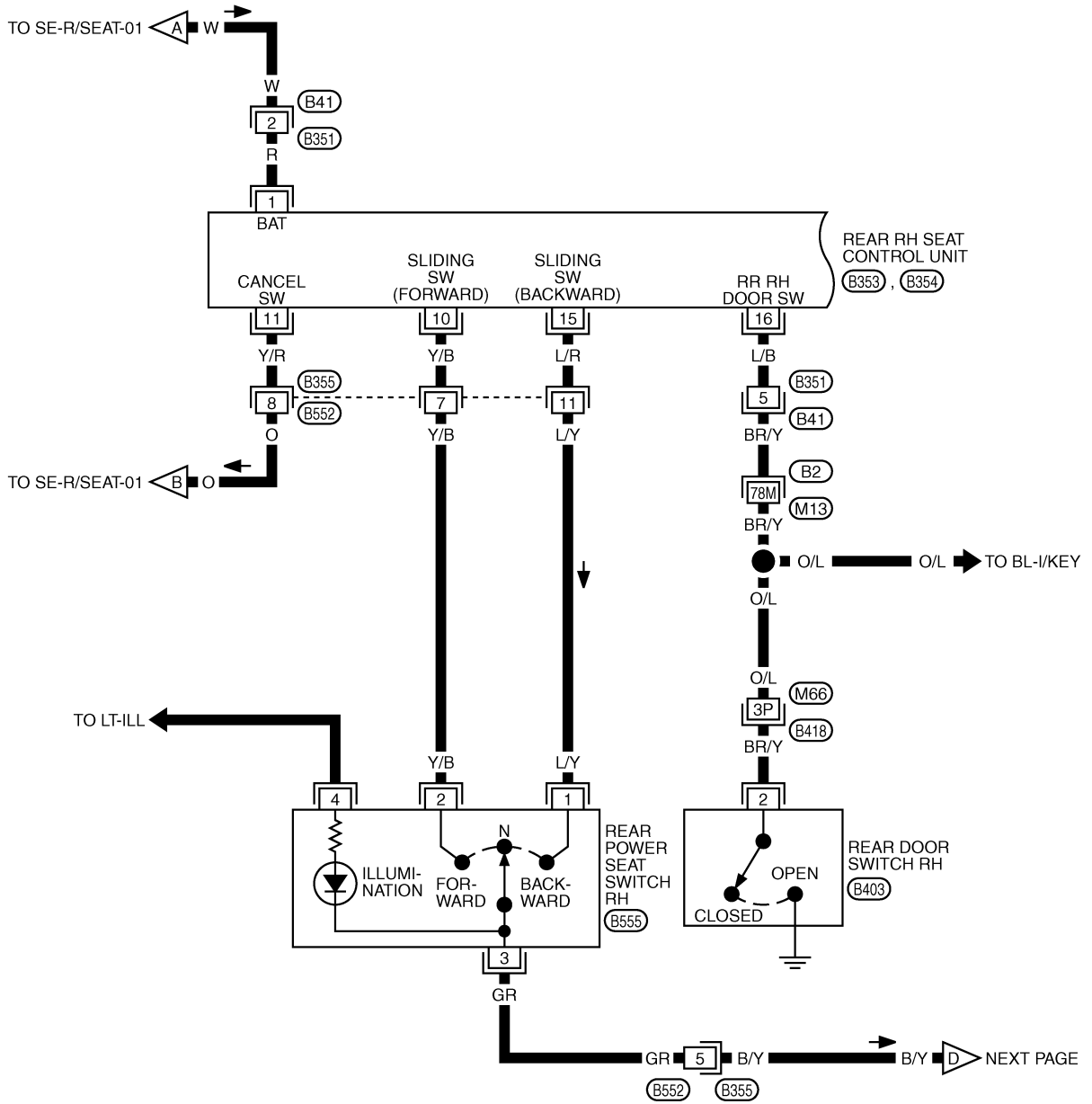

REFER TO THE FOLLOWING.  
 (B2), (B418) -SUPER MULTIPLE JUNCTION (SMJ)

\*: THIS CONNECTOR IS NOT SHOWN IN "HARNESS LAYOUT", PG SECTION.

TIWT2128E

# POWER SEAT(REAR)

SE-R/SEAT-04

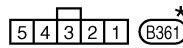
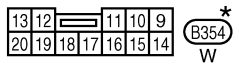
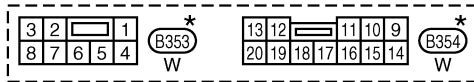
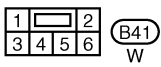
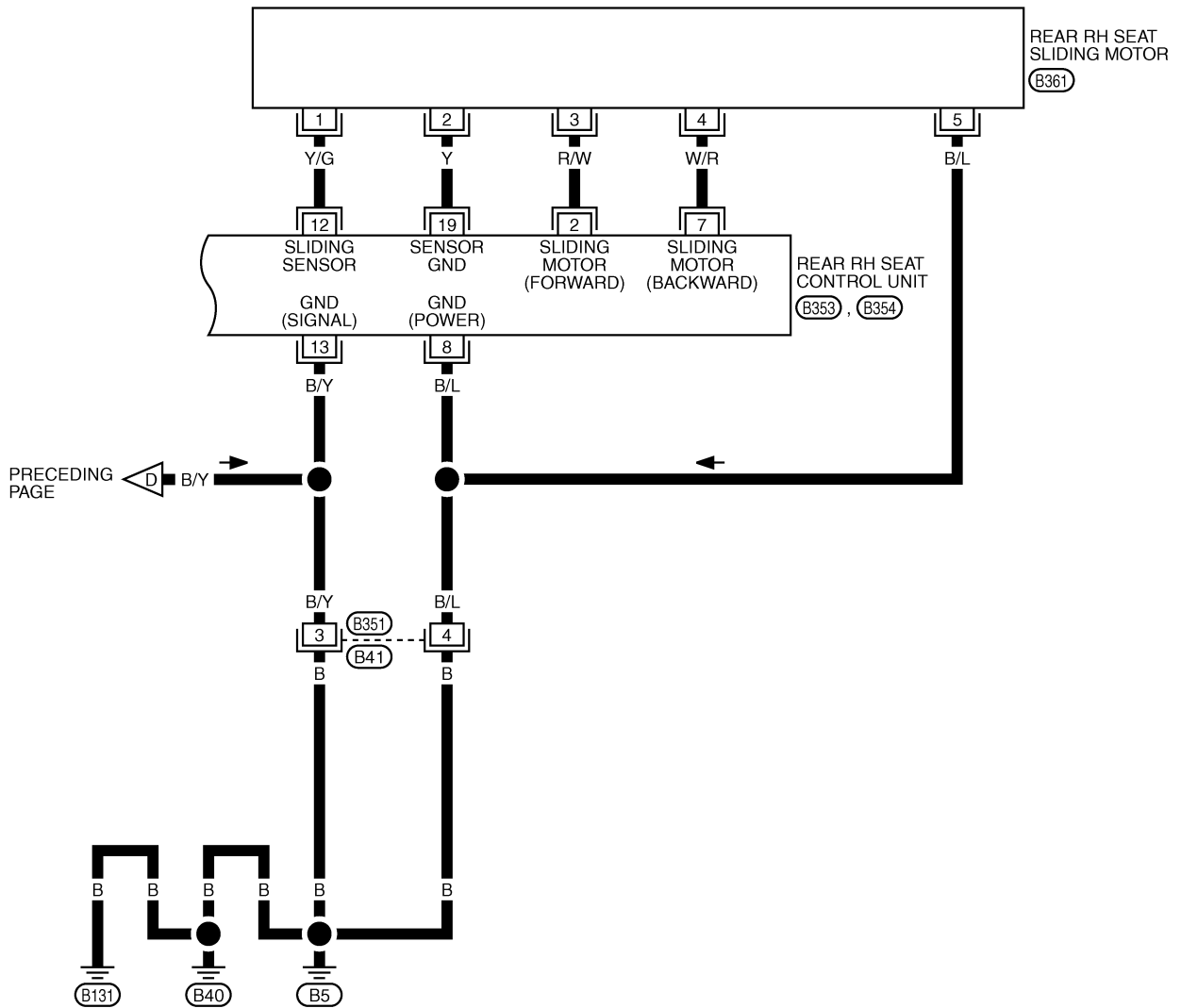

\*: THIS CONNECTOR IS NOT SHOWN IN "HARNESS LAYOUT", PG SECTION.

TIWT1390E

# POWER SEAT(REAR)

## Terminals and Reference Values for Rear Seat Control Unit

NIS00276

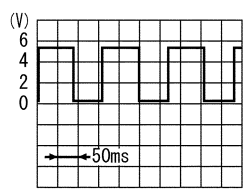
Terminal	Wire Color	Item	Signal Input/Output	Condition	Voltage (V) (Approx.)
1	R	Power source (BAT)	Input	—	Battery voltage
2	R/W	Sliding motor forward signal	Output	When sliding switch forward is operated	Battery voltage
				Other than above	0
7	W/R	Sliding motor backward signal	Output	When sliding switch backward is operated	Battery voltage
				Other than above	0
8	B/L	Ground (power)	—	—	0
10	Y/B	Sliding switch forward signal	Input	When sliding switch forward is operated	0
				Other than above.	Battery voltage
11	Y/R	Cancel switch signal	Input	Cancel switch ON	5
				Cancel switch CANCEL	0
12	Y/G	Sliding sensor signal	Input	Sliding device active	
				Sliding device inactive	0 or 5
13	B/Y	Ground (signal)	—	—	0
15	L/R	Sliding switch backward signal	Input	When sliding switch backward is operated	0
				Other than above	Battery voltage
16	L/B	Rear door switch signal	Input	Rear door open (ON)	0
				Rear door close (OFF)	Battery voltage
19	Y	Sensor ground	—	—	0

A  
B  
C  
D  
E  
F  
G  
H  
SE  
J  
K  
L  
M

# POWER SEAT(REAR)

## Work Flow

NIS00277

1. Check the symptom and customer's requests.
2. Understand the outline of system. Refer to [SE-96, "System Description"](#) .
3. According to the trouble diagnosis chart, repair or replace the cause of the malfunction. Refer to [SE-104, "Trouble Diagnoses Symptom Chart"](#) .
4. Does rear power seat operate normally? YES: GO TO 5, NO: GO TO 4.
5. INSPECTION END.

## Trouble Diagnoses Symptom Chart

NIS00278

- Check that other systems using the signal of the following systems operate normally.

Symptom	Diagnoses / service procedure	Refer to page
Rear power seat LH, RH do not operate.	Check rear power seat power supply circuit	<a href="#">SE-104</a>
Rear power seat LH or RH sliding switch does not operate moreover, retreat function does not operate if the door is opened	1. Check rear seat control unit power supply and ground circuit	<a href="#">SE-105</a>
	2. Check rear seat sliding motor circuit	<a href="#">SE-106</a>
Rear power seat LH or RH does not operate, but retreat function operates when the door is opened	Check rear power seat switch circuit	<a href="#">SE-107</a>
Rear power seat LH and RH retreat function does not operate, but operates by sliding switch	Check automatic return cancel switch	<a href="#">SE-110</a>
Rear power seat LH or RH retreat function does not operate, but operates by a sliding switch	1. Check rear door switch circuit	<a href="#">SE-111</a>
	2. Check automatic return cancel switch circuit	<a href="#">SE-109</a>
	3. Check rear seat sliding sensor circuit	<a href="#">SE-112</a>

## Check Rear Power Seat Power Supply Circuit

NIS00279

### 1. CHECK FUSIBLE LINK

Check 50A fusible link (letter **F** located in the fuse and fusible link box).

#### NOTE:

Refer to [SE-96, "Component Parts and Harness Connector Location"](#) .

OK or NG

OK >> GO TO 2.

NG >> If fuse is blown, be sure to eliminate cause of malfunction before installing new fuse, refer to [PG-3, "POWER SUPPLY ROUTING CIRCUIT"](#) .

### 2. CHECK CIRCUIT BREAKER

Check circuit breaker.

#### NOTE:

Refer to [PG-3, "POWER SUPPLY ROUTING CIRCUIT"](#) .

OK or NG

OK >> Check the condition of the harness and connector.

NG >> Replace the circuit breaker.



# POWER SEAT(REAR)

## Check Rear Seat Control Unit Power Supply and Ground Circuit

NIS0027A

### 1. CHECK REAR SEAT CONTROL UNIT POWER SUPPLY CIRCUIT

1. Turn ignition switch OFF.
2. Check voltage between rear seat control unit connector and ground.

Terminal (+)		Terminal (-)	Voltage (V) (Approx.)
Rear seat control unit connector	Terminal		
B303 (LH) B353 (RH)	1	Ground	Battery voltage

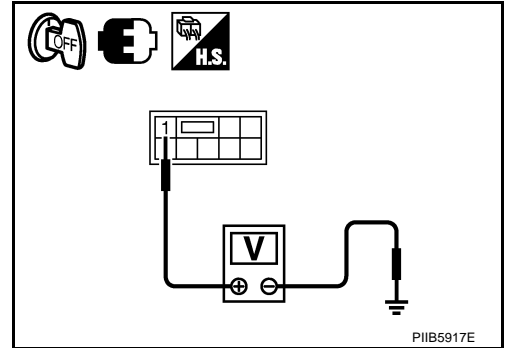

#### OK or NG

OK >> GO TO 2.

NG >> Repair or replace harness between circuit breaker and rear seat control unit.

### 2. CHECK REAR POWER SEAT CONTROL UNIT GROUND CIRCUIT

1. Disconnect rear seat control unit connector.
2. Check continuity between rear seat control unit connector and ground.

Terminal		Continuity
Rear seat control unit connector	Terminal	
B303 (LH) B353 (RH)	8	Ground  Yes
B304 (LH) B354 (RH)	13	

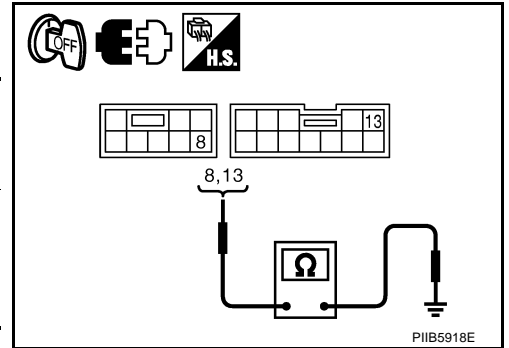

#### OK or NG

OK >> Rear seat control unit power supply and ground circuit is OK.

NG >> Repair or replace harness between rear seat control unit and ground.

# POWER SEAT(REAR)

NIS0027B

## Check Rear Seat Sliding Motor Circuit

### 1. CHECK REAR SEAT SLIDING MOTOR POWER SUPPLY

1. Turn ignition switch OFF.
2. Check voltage between rear seat control unit connector and ground.

Terminal (+)		Terminal (-)	Condition		Voltage (V) (Approx.)
Rear seat control unit connector	Terminal				
B303 (LH) B353 (RH)	2	Ground	Rear power seat switch	Forward	Battery voltage
			Other than above.		0
	7		Rear power seat switch	Backward	Battery voltage
			Other than above.		0

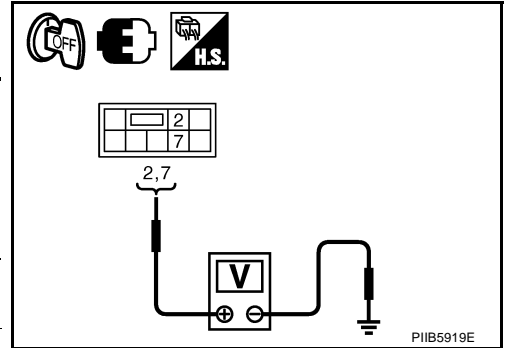

OK or NG

- OK >> GO TO 2.  
NG >> Replace rear seat control unit.

### 2. CHECK REAR SEAT SLIDING MOTOR HARNESS

1. Disconnect rear seat control unit and rear seat sliding motor connector.
2. Check continuity between rear seat control unit connector and rear seat sliding motor connector.

A		B		Continuity
Rear seat control unit connector	Terminal	Rear seat sliding motor connector	Terminal	
B303 (LH) B353 (RH)	2	B311 (LH) B361 (RH)	3	Yes
	7		4	

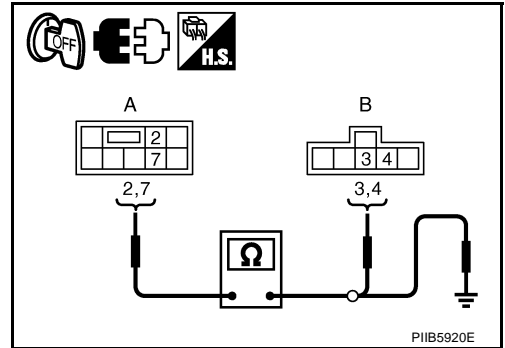

3. Check continuity between rear seat control unit connector and ground.

A		Ground	Continuity
Rear seat control unit connector	Terminal		
B303 (LH) B353 (RH)	2		No
	7		

OK or NG

- OK >> Replace rear seat sliding motor.  
NG >> Repair or replace harness between rear seat control unit and rear seat sliding motor.

# POWER SEAT(REAR)

NIS0027C

## Check Rear Power Seat Switch Circuit

### 1. CHECK REAR POWER SEAT SWITCH POWER SUPPLY

1. Turn ignition switch OFF.
2. Check voltage between rear seat control unit connector and ground.

Terminal (+)		Terminal (-)	Condition		Voltage (V) (Approx.)
Rear seat control unit connector	Terminal				
B304 (LH) B354 (RH)	10	Ground	Rear power seat switch	Forward	0
			Other than above.		Battery voltage
	15		Rear power seat switch	Backward	0
			Other than above.		Battery voltage

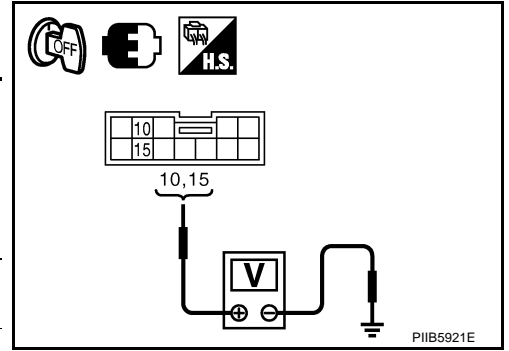

#### OK or NG

- OK >> Replace rear seat control unit.  
 NG >> GO TO 2.

### 2. CHECK REAR POWER SEAT SWITCH HARNESS

1. Disconnect rear seat control unit connector and rear power seat switch connector.
2. Check continuity between rear seat control unit connector and rear power seat switch connector.

A		B		Continuity
Rear seat control unit connector	Terminal	Rear power seat switch connector	Terminal	
B304 (LH) B354 (RH)	10	B504 (LH) B555 (RH)	2	Yes
	15		1	

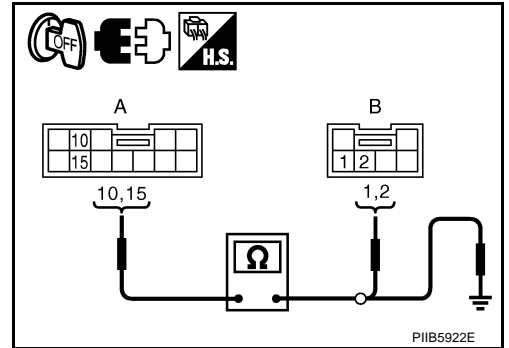

3. Check continuity between rear seat control unit connector and ground.

A		Ground	Continuity
Rear seat control unit connector	Terminal		
B304 (LH) B354 (RH)	10		No
	15		

#### OK or NG

- OK >> GO TO 3.  
 NG >> Repair or replace harness between rear seat control unit and rear power seat switch.

# POWER SEAT(REAR)

## 3. CHECK REAR POWER SEAT SWITCH

Check continuity between rear power seat switch as follows.

Rear power seat switch connector	Terminal		Condition		Continuity
	1	3	Rear power seat switch	Backward	
B504 (LH) B555 (RH)	1	3	Rear power seat switch	Backward	Yes
			Other than above.		No
	2	3	Rear power seat switch	Forward	Yes
			Other than above.		No

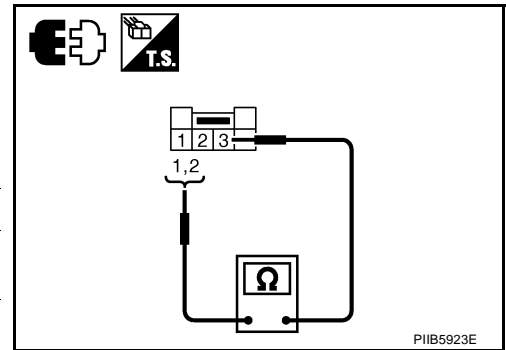

OK or NG

OK >> GO TO 4.

NG >> Replace rear power seat switch.

## 4. CHECK REAR POWER SEAT SWITCH GROUND CIRCUIT

Check continuity between rear power seat switch connector and ground.

Rear power seat switch connector	Terminal		Continuity
	Terminal	Ground	
B504 (LH) B555 (RH)	3	Ground	Yes

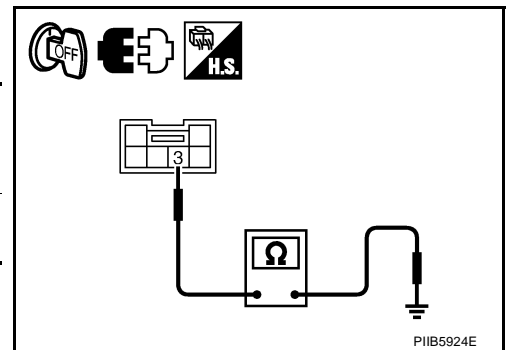

OK or NG

OK >> GO TO 5.

NG >> Repair or replace harness between rear power seat switch and ground.

## 5. CHECK REAR POWER SEAT SWITCH POWER SUPPLY-2

1. Connect rear seat control unit connector.
2. Check voltage between rear seat control unit connector and ground.

Terminals		Voltage (V) (Approx.)	
(+)	(-)		
Rear seat control unit connector	Terminal		
B304 (LH) B354 (RH)	10	Ground	Battery voltage
	15		

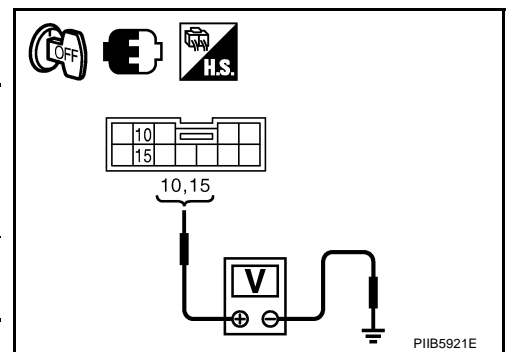

OK or NG

OK >> Check the condition of the harness and connector.

NG >> Replace rear seat control unit.

# POWER SEAT(REAR)

NIS0027D

## Check Automatic Return Cancel Switch Circuit

### 1. CHECK AUTOMATIC RETURN CANCEL SWITCH POWER SUPPLY-1

1. Turn ignition switch OFF.
2. Check voltage between rear seat control unit connector and ground.

Terminal (+)		Terminal (-)	Condition	Voltage (V) (Approx.)
Rear seat control unit connector	Terminal			
B304 (LH) B354 (RH)	11	Ground	Automatic return cancel switch ON and, rear door open	5
			Other than above.	0

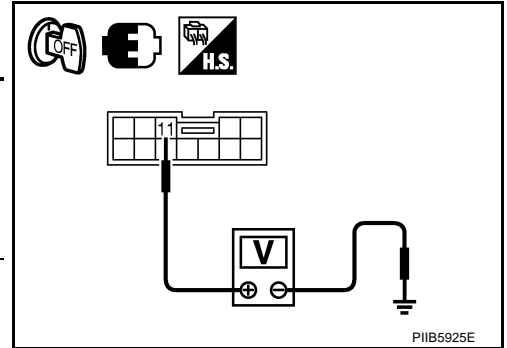

#### OK or NG

- OK >> Automatic return cancel switch circuit is OK.  
 NG >> GO TO 2.

### 2. CHECK AUTOMATIC RETURN CANCEL SWITCH HARNESS

1. Disconnect rear seat control unit connector and automatic return cancel switch connector.
2. Check continuity between rear seat control unit connector and automatic return cancel switch connector.

A		B		Continuity
Rear seat control unit connector	Terminal	Automatic return cancel switch connector	Terminal	
B304 (LH) B354 (RH)	11	B508	1	Yes

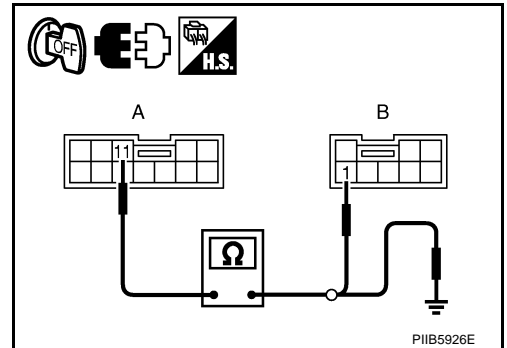

3. Check continuity between rear seat control unit connector and ground.

A		Ground	Continuity
Rear seat control unit connector	Terminal		
B304 (LH) B354 (RH)	11		No

#### OK or NG

- OK >> GO TO 3.  
 NG >> Repair or replace harness between rear seat control unit and automatic return cancel switch.

A  
B  
C  
D  
E  
F  
G  
H  
SE  
J  
K  
L  
M

# POWER SEAT(REAR)

## 3. CHECK AUTOMATIC RETURN CANCEL SWITCH POWER SUPPLY-2

1. Connect rear seat control unit connector.
2. Check voltage between rear seat control unit connector and ground.

Terminals		(-)	Voltage (V) (Approx.)
(+) Rear seat control unit connector			
Rear seat control unit connector	Terminal		
B304 (LH) B354 (RH)	11	Ground	5

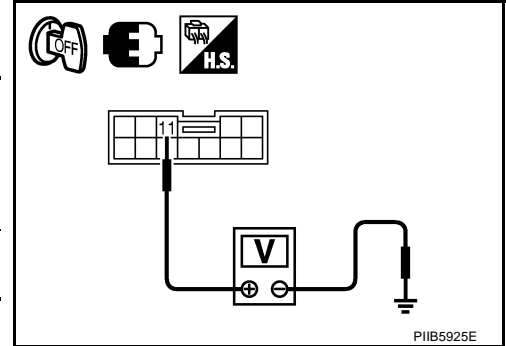

OK or NG

- OK >> Check the condition of the harness and connector.  
 NG >> Replace rear seat control unit.

## Check Automatic Return Cancel Switch

### 1. CHECK AUTOMATIC RETURN CANCEL SWITCH

1. Turn ignition switch OFF.
2. Disconnect automatic return cancel switch connector.
3. Check continuity between automatic return cancel switch as follows.

Automatic return cancel switch connector	Terminal		Condition	Continuity
	1	3		
B508	1	3	CANCEL	Yes
			ON	No

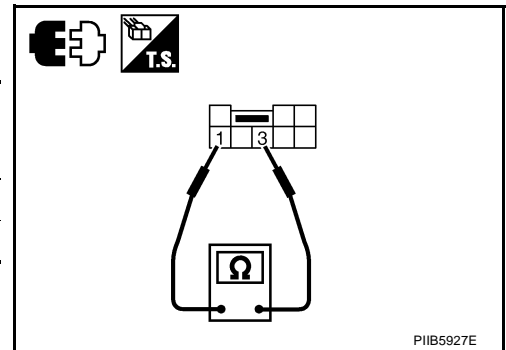

OK or NG

- OK >> GO TO 2.  
 NG >> Replace automatic return cancel switch.

### 2. CHECK AUTOMATIC RETURN CANCEL SWITCH GROUND HARNESS

Check continuity between automatic return cancel switch connector and ground.

Terminal		Ground	Continuity
Automatic return cancel switch connector	Terminal		
B508	3		Yes

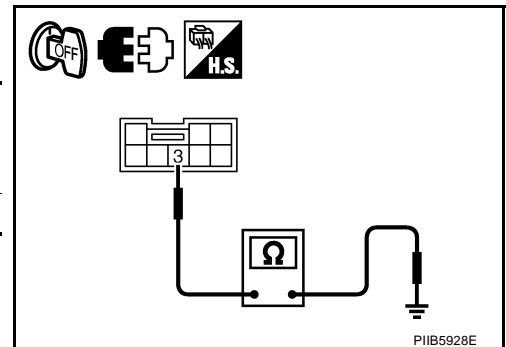

OK or NG

- OK >> Check the harness and connector.  
 NG >> Repair or replace harness between automatic return cancel switch and ground.

# POWER SEAT(REAR)

NIS0027F

## Check Rear Door Switch Circuit

### 1. CHECK REAR DOOR SWITCH POWER SUPPLY-1

1. Turn ignition switch OFF.
2. Check voltage between rear seat control unit connector and ground.

Terminal (+)		Terminal (-)	Condition	Voltage (V) (Approx.)
Rear seat control unit connector	Terminal			
B304 (LH) B354 (RH)	16	Ground	Rear door open.	0
			Rear door closed.	Battery voltage

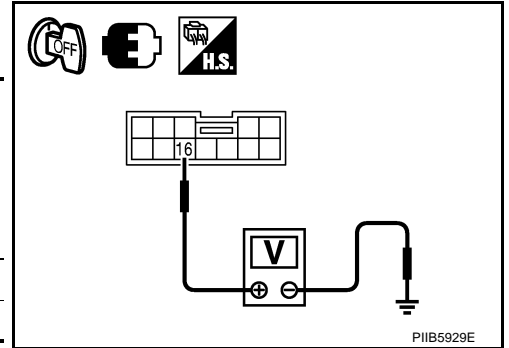

#### OK or NG

- OK >> Rear door switch circuit is OK.  
 NG >> GO TO 2.

### 2. CHECK REAR DOOR SWITCH HARNESS

1. Disconnect rear seat control unit connector and rear door switch connector.
2. Check continuity between rear seat control unit connector and rear door switch connector.

A		B		Continuity
Rear seat control unit connector	Terminal	Rear door switch connector	Terminal	
B304 (LH) B354 (RH)	16	B53 (LH) B403 (RH)	2	Yes

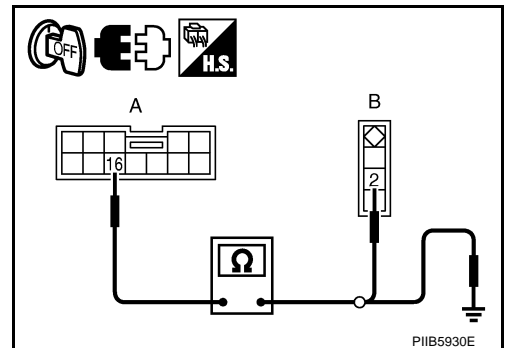

3. Check continuity between rear seat control unit connector and ground.

A		Ground	Continuity
Rear seat control unit connector	Terminal		
B304 (LH) B354 (RH)	16		No

#### OK or NG

- OK >> GO TO 3.  
 NG >> Repair or replace harness between rear seat control unit and rear door switch.

### 3. CHECK REAR DOOR SWITCH

Check continuity between rear door switch and ground.

Rear door switch connector	Terminal	Condition	Continuity
B53 (LH) B403 (RH)	2		
		Rear door open.	Yes
		Rear door closed.	No

#### OK or NG

- OK >> GO TO 4.  
 NG >> Replace rear door switch.

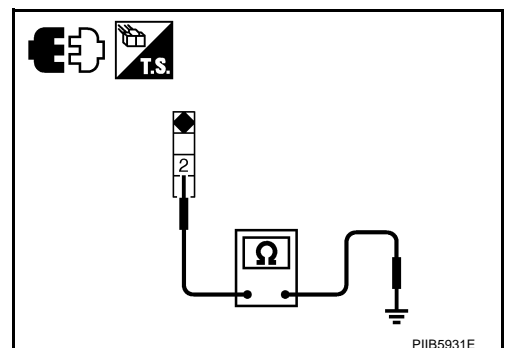

# POWER SEAT(REAR)

## 4. CHECK REAR DOOR SWITCH POWER SUPPLY-2

1. Connect rear seat control unit connector.
2. Check voltage between rear seat control unit connector and ground.

Terminals		(-)	Voltage (V) (Approx.)
(+) Rear seat control unit connector			
Rear seat control unit connector	Terminal		
B304 (LH) B354 (RH)	16	Ground	Battery voltage

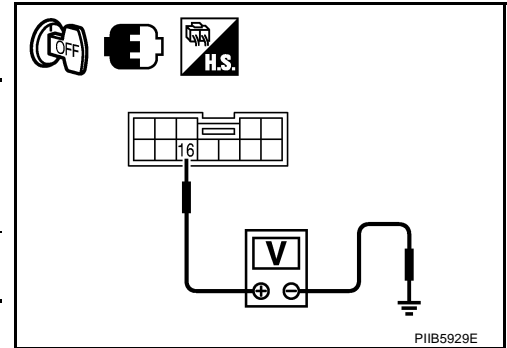

**OK or NG**

- OK >> Check the condition of the harness and connector.  
 NG >> Replace rear seat control unit.

## Check Rear Seat Sliding Sensor Circuit

NIS0027G

### 1. CHECK REAR SEAT SLIDING SENSOR POWER SUPPLY

1. Turn ignition switch OFF.
2. Check signal between rear seat control unit connector and ground with oscilloscope.

Terminal		(-)	Condition	Signal (Reference valve)
(+) Rear seat control unit connector				
Rear seat control unit connector	Terminal			
B304 (LH) B354 (RH)	12	Ground	Sliding device active	<p>(V) 6 4 2 0</p> <p>← 50ms</p> <p>SIIA0690J</p>

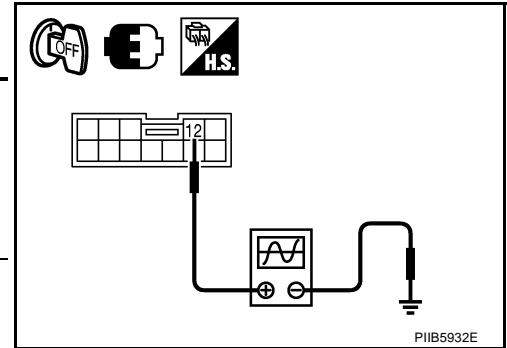

**OK or NG**

- OK >> Check the condition of the harness and connector.  
 NG >> GO TO 2.



# POWER SEAT(REAR)

## 2. CHECK REAR SEAT SLIDING SENSOR HARNESS

1. Disconnect rear seat control unit connector and rear seat sliding motor connector.
2. Check continuity between rear seat control unit connector and rear seat sliding motor connector.

A		B		Continuity
Rear seat control unit connector	Terminal	Rear seat sliding motor connector	Terminal	
B304 (LH) B354 (RH)	12	B311 (LH) B361 (RH)	1	Yes
	19		2	

3. Check continuity between rear seat control unit connector and ground.

A		Ground	Continuity
Rear seat control unit connector	Terminal		
B304 (LH) B354 (RH)	12		No
	19		

### OK or NG

- OK >> Replace rear seat sliding motor.  
 NG >> Repair or replace harness between rear seat control unit and rear seat sliding motor.

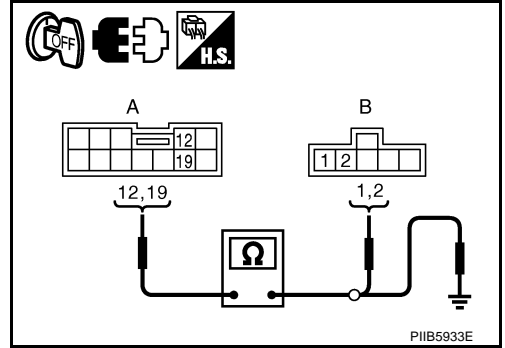

A  
B  
C  
D  
E  
F  
G  
H  
SE  
J  
K  
L  
M

# CLIMATE CONTROLLED SEAT

PFP:870U6

## CLIMATE CONTROLLED SEAT

### Component Parts and Harness Connector Location

NIS0027H

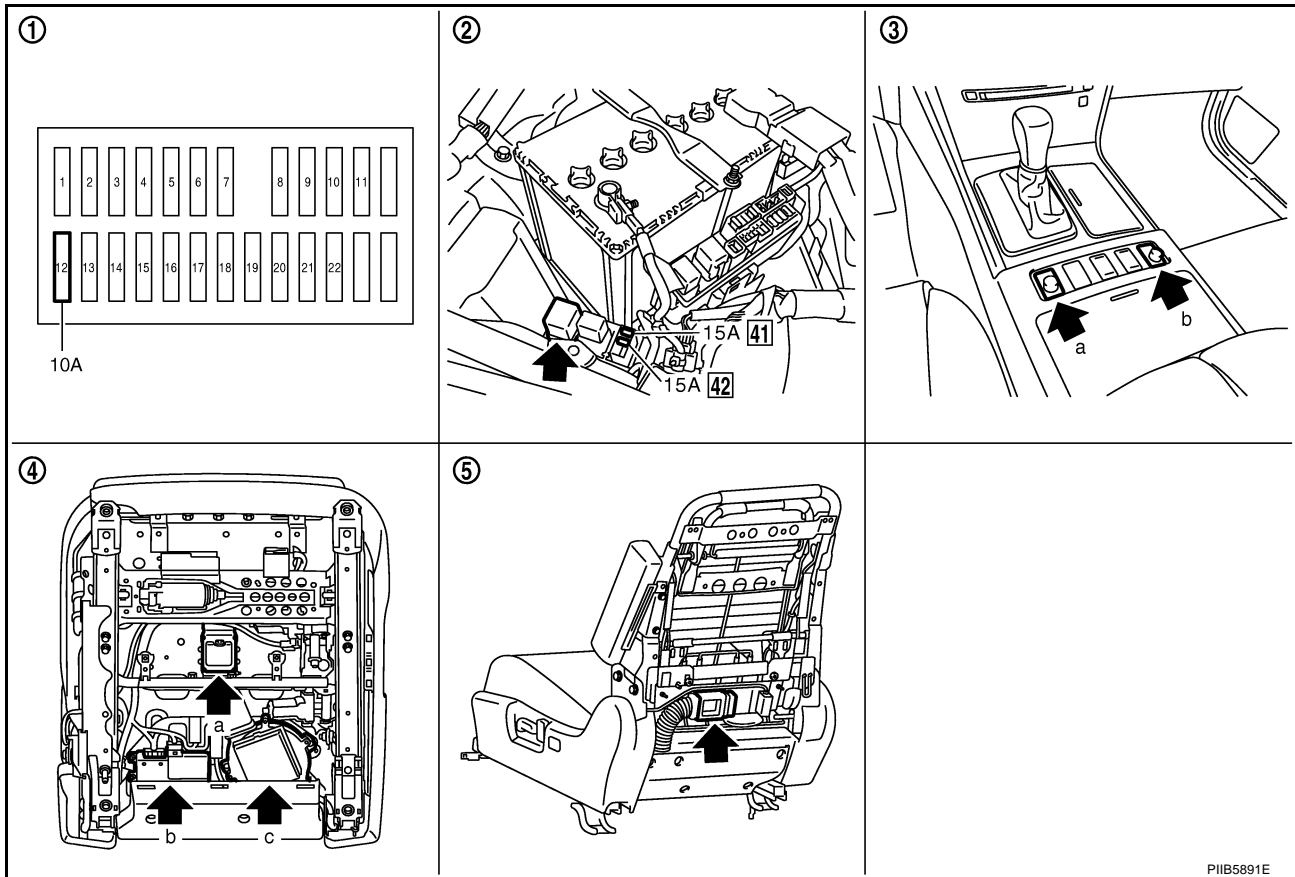

PIIB5891E

1. Fuse block (J/B)

2. Climate controlled seat relay E16

3.

a: Climate controlled seat switch driver side B430

b: Climate controlled seat switch passenger side B429

a: Seat cushion thermal electric device B285 (driver side)  
B295 (passenger side)

4. b: Climate controlled seat control unit B283, B284 (driver side)  
B293, B294 (passenger side)

c: Climate controlled seat blower motor B282 (driver side)  
B292 (passenger side)

5. a: Seatback thermal electric device B220 (driver side)  
B258 (passenger side)

## System Description

NIS0027I

The climate controlled seat system is controlled by climate controlled seat control unit. Heating and cooling are possible for a thermal electric device (heat conversion machine).

### NOTE:

- The climate controlled seat system is downed when the temperature sensor set as the seat cushion and the seat back's thermal electric device machine detects 20 °C (68 °F) or more of mutual differences of temperature.
- In this case, by turning off ignition switch, system down is canceled and it can be reused by turning on ignition switch again.
- The climate controlled seat blower keep low speed for approximately 60 seconds after turning the climate controlled seat switch.

### CAUTION:

- **The thermal electric device has the character in which, as for an opposite side. one side becomes high temperature at the time of low temperature.**

# CLIMATE CONTROLLED SEAT

- **At the time of work, please turn OFF a switch, and carry it out after checking that the thermal electric device has got cold.**

Power is at all times supplied

- through 15A fuse [No. 41 located in the fuse fusible link and relay unit]
- to climate controlled seat relay terminals 5.
- through 15A fuse [No. 42 located in the fuse fusible link and relay unit]
- to climate controlled seat relay terminals 7.

When the ignition switch turned to ON or START position,  
Power is supplied

- through 10A fuse [No. 12, located in the fuse block (J/B)]
- to climate controlled seat relay terminal 2.

Then ground is supplied

- to climate controlled seat relay terminal 1,
- through body grounds E22 and E43.

Then climate controlled seat relay is energized.

When climate controlled seat relay is turned to ON,  
Power is supplied,

- through climate controlled seat relay terminal 3,
- to climate controlled seat control unit (passenger side) terminal 2 and 4.
- through climate controlled seat relay terminal 6,
- to climate controlled seat control unit (driver side) terminal 2 and 4.

When climate controlled switch select HEAT, ground is supplied

- through climate controlled seat switch terminal 1 and 3,
- to climate controlled seat control unit terminal 10.

Then, the climate controlled seat control unit receives climate controlled seat switch HEAT signal.

When climate controlled seat switch select COOL, ground is supplied

- through climate controlled seat switch terminal 1 and 2,
- to climate controlled seat control unit terminal 20,

Then, the climate controlled seat control unit receives climate controlled switch COOL signal.

When blower motor rotates, signal is transmitted

- to climate controlled seat control unit terminal 18,
- through climate controlled seat blower motor terminal 1.

This is climate controlled seat blower motor tachometer signal.

When climate controlled seat control unit receives climate controlled seat switch signal and tachometer signal,  
Power is supplied

- to climate controlled seat blower motor terminal 4,
- through climate controlled seat control unit terminal 17.

This is blower motor revolution control signal.

When blower motor receivers blower motor revolution control signal,  
Power is supplied

- through climate controlled seat control unit terminal 14,
- to climate controlled seat blower motor terminal 2.

When number of rotations correspond signal,

Ground is supplied

- to climate controlled seat blower motor terminal 3,
- through climate controlled seat control unit terminal 7,
- through climate controlled seat control unit terminal 3,
- through body grounds B5, B40 and B131.

Then motor revolution is controlled.

When the ignition switch turned to ON or START position,  
Power is supplied

A

B

C

D

E

F

G

H

SE

J

K

L

M

## CLIMATE CONTROLLED SEAT

---

- to seat cushion thermal electric device terminal 1,
- through climate controlled seat control unit terminal 22.

Then ground is supplied

- to climate controlled seat control unit terminal 21,
- through seat cushion thermal electric device terminal 2,

Then the climate controlled seat control unit recognizes seat cushion thermal electric device sensor signal.

When climate controlled seat control unit recognizes climate controlled seat switch HEAT signal and, seat cushion thermal electric device sensor signal,

Power is supplied

- to seat cushion thermal electric device terminal 4,
- through climate controlled seat control unit terminal 5.

Then ground is supplied

- through seat cushion thermal electric device terminal 6,
- to climate controlled seat control unit terminal 6,
- through climate controlled seat control unit terminal 3,
- through body grounds B5, B40 and B131.

When climate controlled seat control unit recognizes climate controlled seat switch COOL signal and seat cushion thermal electric device sensor signal,

Power is supplied

- to seat cushion thermal electric device terminal 6,
- through climate controlled seat control unit terminal 6.

Then ground is supplied

- through seat cushion thermal electric device terminal 4,
- to climate controlled seat control unit terminal 5.
- through climate controlled seat control unit terminal 3,
- through body grounds B5, B40 and B131.

When the ignition switch turned to ON or START position,

Power is supplied

- to seatback thermal electric device terminal 1,
- through climate controlled seat control unit terminal 23.

Then ground is supplied

- to climate controlled seat control unit terminal 24,
- through seatback thermal electric device terminal 2,
- through climate controlled seat control unit terminal 3,
- through body grounds B5, B40 and B131.

Then the climate controlled seat control unit recognizes seatback thermal electric device sensor signal.

When climate controlled seat control unit recognizes climate controlled seat switch HEAT signal and seatback thermal electric device sensor signal,

Power is supplied

- to seatback thermal electric device terminal 4,
  - through climate controlled seat control unit terminal 15,
- ground is supplied

- to climate controlled seat control unit terminal 16,
- through seatback thermal electric device terminal 6,
- through climate controlled seat control unit terminal 3,
- through body grounds B5, B40 and B131.

This seatback thermal electric device generates heat wind is warmed.

When climate controlled seat control unit recognizes climate controlled seat switch COOL signal and seatback thermal electric device sensor signal,

Power is supplied

- to seatback thermal electric device terminal 6,

## CLIMATE CONTROLLED SEAT

---

- through climate controlled seat control unit terminal 16,  
ground is supplied

A

- to climate controlled seat control unit terminal 15,
- through seatback thermal electric device terminal 4,
- through climate controlled seat control unit terminal 3,
- through body grounds B5, B40 and B131.

B

When climate controlled switch selects HEAT,  
Power is supplied

C

- to climate controlled seat switch terminal 5,
- through climate controlled seat control unit terminal 8.

D

Ground is supplied

- to the climate controlled seat switch terminal 6,
- through body grounds B402 and B405.

E

Then climate controlled seat switch HEAT indicator is energized.

When climate controlled switch select COOL,  
Power is supplied

F

- to climate controlled seat switch terminal 4,
- through climate controlled seat control unit terminal 9.

Ground is supplied

G

- to the climate controlled seat switch terminal 6,
- through body grounds B402 and B405.

H

Then climate controlled seat switch COOL indicator is energized.

SE

J

K

L

M

# CLIMATE CONTROLLED SEAT

## Schematic

NIS0027J

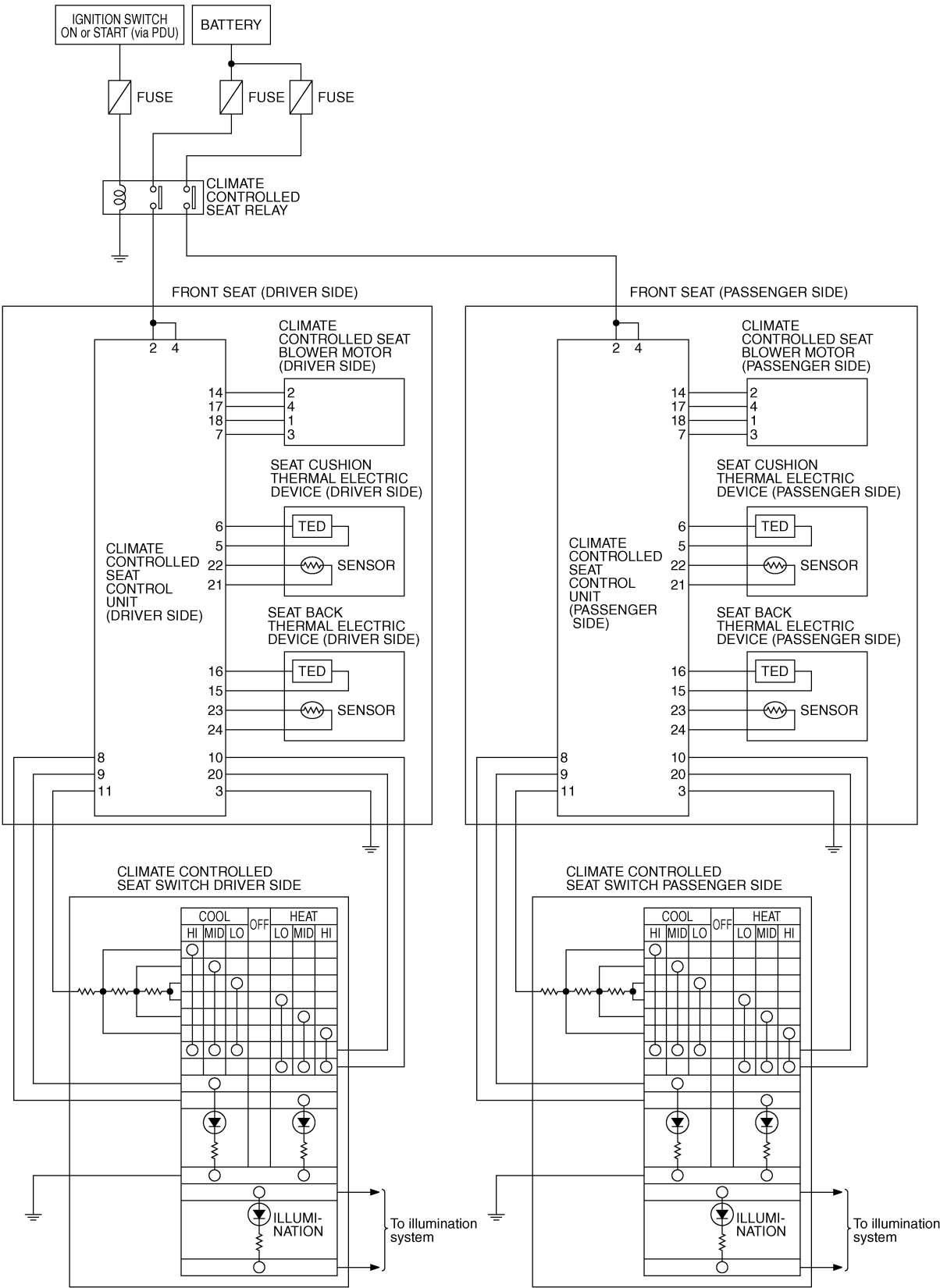

TIWT1391E

# CLIMATE CONTROLLED SEAT

## Wiring Diagram — C/SEAT —

NIS0027K

SE-C/SEAT-01

A  
B  
C  
D  
E  
F  
G  
H  
SE  
J  
K  
L  
M

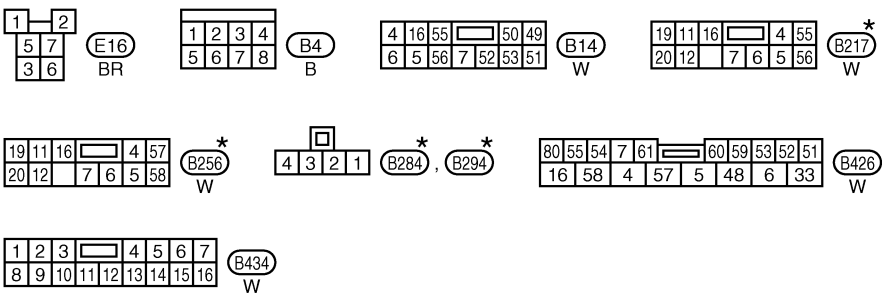
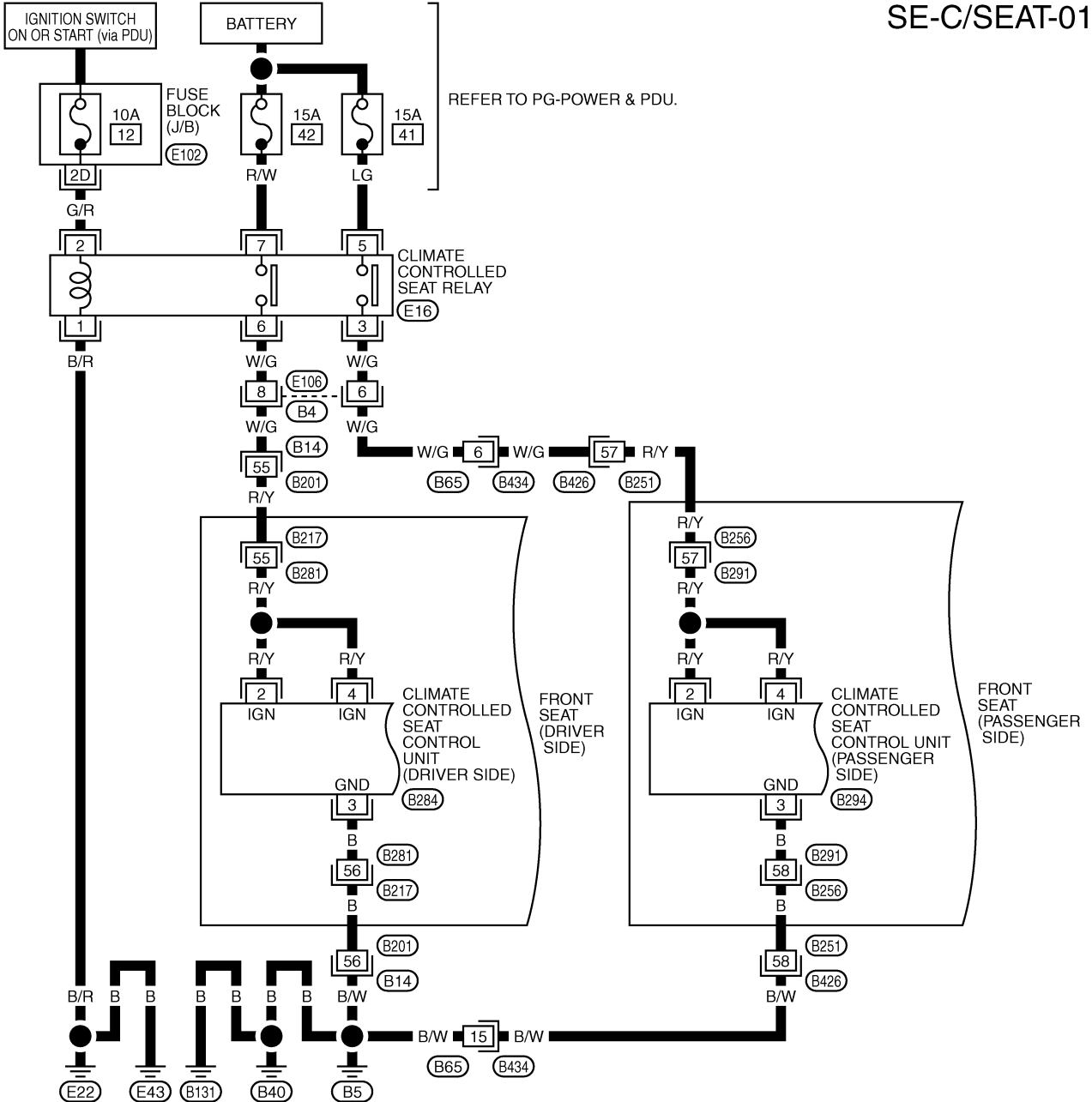

REFER TO THE FOLLOWING.  
E102 - FUSE BLOCK-JUNCTION BOX (J/B)

\*: THIS CONNECTOR IS NOT SHOWN IN "HARNESS LAYOUT", PG SECTION.





# CLIMATE CONTROLLED SEAT

SE-C/SEAT-03

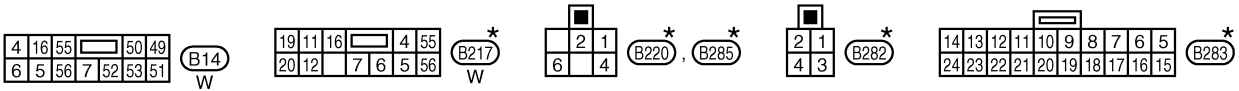
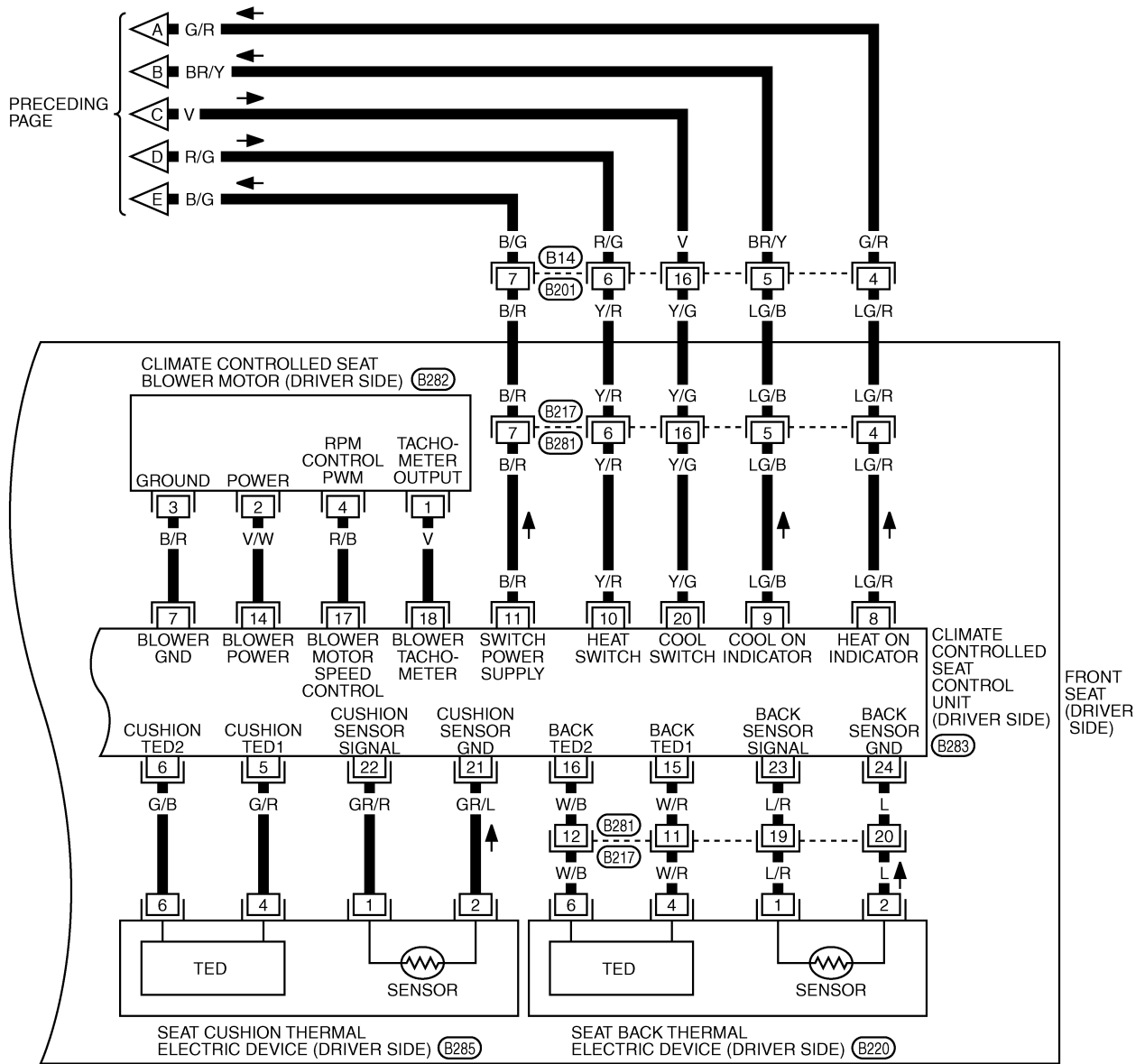

\*: THIS CONNECTOR IS NOT SHOWN IN "HARNESS LAYOUT", PG SECTION.

TIWT1394E

# CLIMATE CONTROLLED SEAT

SE-C/SEAT-04

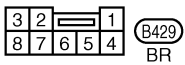
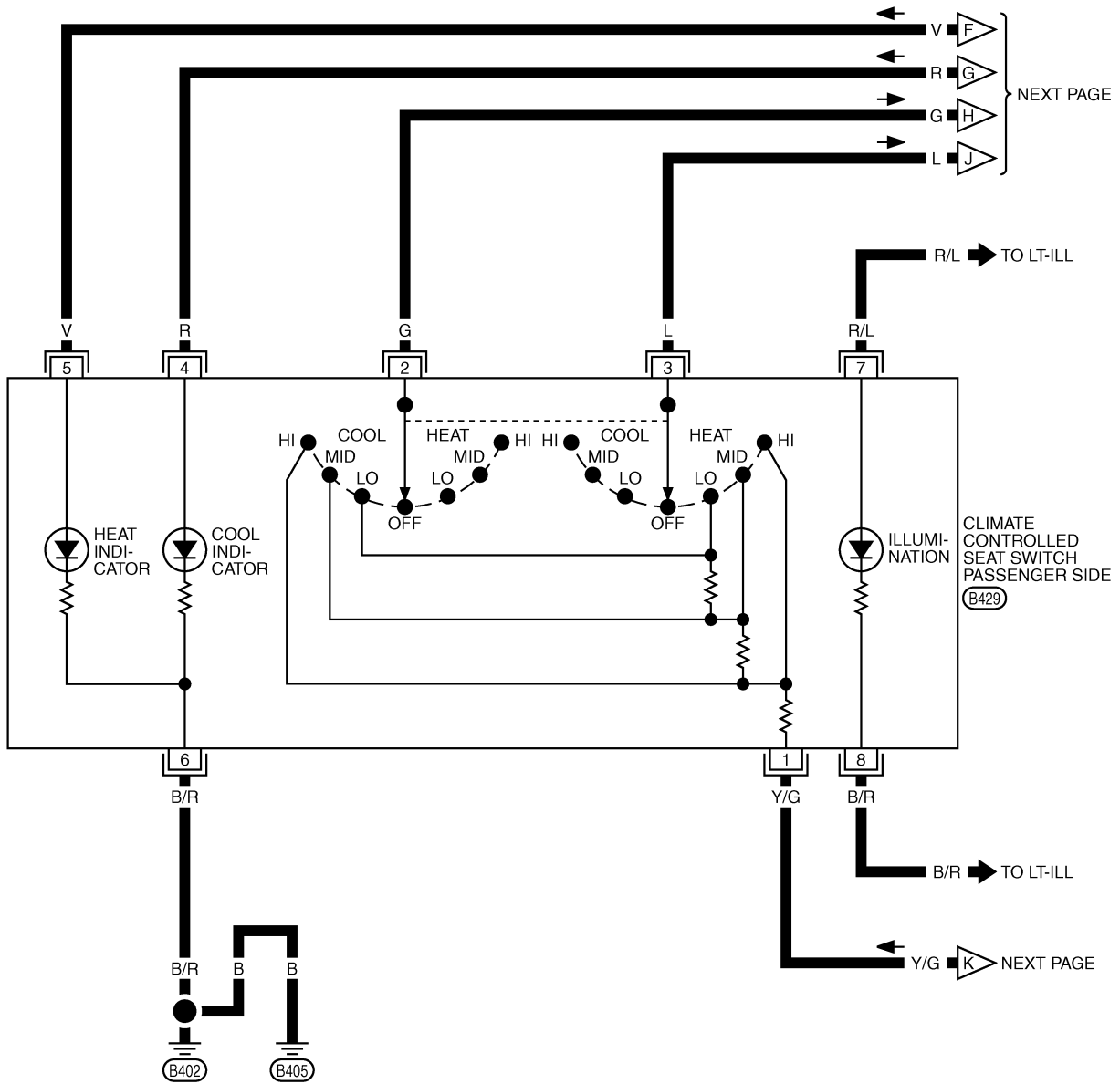

TIWT2131E

# CLIMATE CONTROLLED SEAT

SE-C/SEAT-05

A  
B  
C  
D  
E  
F  
G  
H  
SE  
J  
K  
L  
M

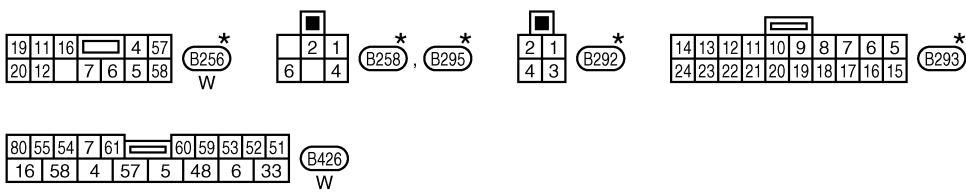
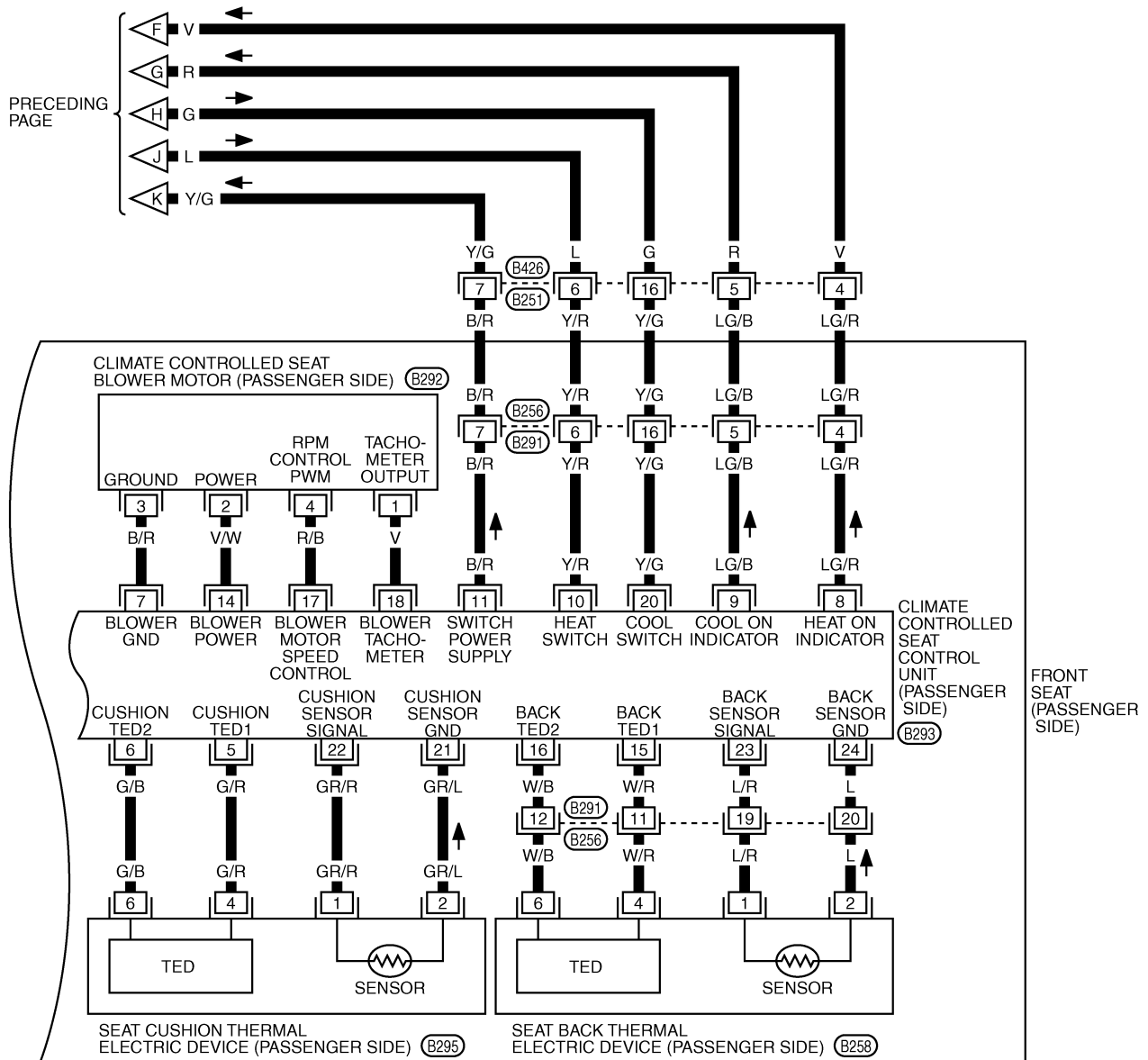

\*: THIS CONNECTOR IS NOT SHOWN IN "HARNESS LAYOUT", PG SECTION.

TIWT2132E

# CLIMATE CONTROLLED SEAT

## Terminal and Reference Value for Climate Controlled Seat Control Unit

NIS0027L

Terminal	Wire Color	Item	Signal Input/Output	Condition			Voltage (V) (Approx)
2	R/Y	Ignition switch power supply	Input	Ignition switch ON or START			Battery voltage
3	B	Ground	—	—			0
4	R/Y	Ignition switch power supply	Input	Ignition switch ON or START			Battery voltage
5	G/R	Seat cushion thermal electric device power supply (HEAT)	Input	Ignition switch ON or START	Climate controlled seat switch select	HEAT or COOL	0 – Battery voltage
						OFF	0
6	G/B	Seat cushion thermal electric device power supply (COOL)	Input	Ignition switch ON or START	Climate controlled seat switch select	COOL or HEAT	0 – Battery voltage
						OFF	0
7	B/R	Blower motor ground	—	—			0
8	LG/R	HEAT switch indicator signal	Output	Ignition switch ON or START	Climate controlled seat switch select	HEAT	Battery voltage
						OFF	0
9	LG/B	COOL switch indicator signal	Output	Ignition switch ON or START	Climate controlled seat switch select	COOL	Battery voltage
						OFF	0
10	Y/R	HEAT switch signal	Input	Ignition switch ON or START	Climate controlled seat switch select	HI HEAT	2.6 – 3.5
						MID HEAT	1.6 – 2.5
						LO HEAT	0.5 – 1.5
						OFF	0
11	B/R	Climate controlled seat switch power supply	Input	Ignition switch ON or START			Battery voltage
14	V/W	Blower motor power supply	Input	Ignition switch ON or START			Battery voltage
15	W/R	Seatback thermal electric device power supply (HEAT)	Input	Ignition switch ON or START	Climate controlled seat switch select	HEAT or COOL	0 – Battery voltage
						OFF	0
16	W/B	Seatback thermal electric device power supply (COOL)	Input	Ignition switch ON or START	Climate controlled seat switch select	COOL or HEAT	0 – Battery voltage
						OFF	0
17	R/B	Blower motor speed control signal	Input	Ignition switch ON or START	Climate controlled seat switch select	HEAT or COOL	4.5 – 8.0
						OFF	0
18	V	Blower motor tachometer signal	Output	Ignition switch ON or START	Climate controlled seat switch select	HEAT or COOL	4.5 – 8.0
						OFF	Battery voltage
20	Y/G	COOL switch signal	Input	Ignition switch ON or START	Climate controlled seat switch select	HI COOL	2.6 – 3.5
						MID COOL	1.6 – 2.5
						LO COOL	0.5 – 1.5
						OFF	0
21	GR/L	Seat cushion thermal electric device sensor ground	—	Ignition switch ON			0
22	GR/R	Seat cushion thermal electric device sensor signal	Input	Blower motor operated			0.5 – 4
				Ignition switch OFF			0

# CLIMATE CONTROLLED SEAT

Ter- minal	Wire Color	Item	Signal Input/ Output	Condition	Voltage (V) (Approx)
23	L/R	Seatback thermal electric device sensor signal	Input	Blower motor operated	0.5 – 4
				Ignition switch OFF	0
24	L	Seatback thermal electric device sensor ground	—	Ignition switch ON	0

## Work Flow

NIS0027M

1. Check the symptom and customer's requests.
2. Understand the outline of system. Refer to [SE-114, "System Description"](#) .
3. Perform the preliminary check. Refer to [SE-126, "Preliminary Check"](#) .
4. According to the trouble diagnosis chart, repair or replace the cause of the malfunction. Refer to [SE-126, "Trouble Diagnoses Symptom Chart"](#) .
5. Does climate controlled seat operate normally? YES: GO TO 6, NO: GO TO 4.
6. INSPECTION END.

A  
B  
C  
D  
E  
F  
G  
H  
J  
K  
L  
M

SE

# CLIMATE CONTROLLED SEAT

## Trouble Diagnoses Symptom Chart

NIS00270

### NOTE:

Make sure other systems using the signal of the following systems operate normally.

Symptom	Diagnoses / service procedure	Refer to page
Climate controlled seat do not operate (Neither the driver's side nor passenger's side operate).	1. Check climate controlled seat control unit power supply circuit	<a href="#">SE-127</a>
All the driver side or passenger side climate controlled seat do not operate.	1. Check climate controlled seat control unit power supply and ground circuit	<a href="#">SE-128</a>
	2. Check climate controlled seat switch power supply circuit	<a href="#">SE-131</a>
	3. Check climate controlled seat blower motor circuit	<a href="#">SE-141</a>
	4. Replace climate controlled seat control unit	<a href="#">SE-114</a>
Climate controlled seat blower motor speed cannot adjust.	1. Check climate controlled seat switch power supply circuit	<a href="#">SE-131</a>
	2. Check climate controlled seat switch circuit	<a href="#">SE-132</a>
	3. Check climate controlled seat control unit	<a href="#">SE-143</a>
	4. Replace climate controlled seat blower motor	<a href="#">SE-114</a>
The climate controlled seat dose not operates when the switch is done in HEAT or COOL.	Check climate controlled seat switch circuit	<a href="#">SE-132</a>
When the climate controlled seat switch is turned on, operation stops at nose (When the climate controlled seat switch is in HEAT or COOL mode after ignition switch is turned ON again, the motor operates).	1. Check seat cushion thermal electric device sensor circuit	<a href="#">SE-138</a>
	2. Check seat cushion thermal electric device circuit	<a href="#">SE-136</a>
	3. Check seatback thermal electric device sensor circuit	<a href="#">SE-140</a>
	4. Check seatback thermal electric device circuit	<a href="#">SE-137</a>
	5. Check climate controlled seat blower motor circuit	<a href="#">SE-141</a>
	6. Replace Climate controlled seat control unit	<a href="#">SE-114</a>
The climate controlled seat switch indicator do not operated with HEAT or COOL position	Check climate controlled seat switch indicator circuit	<a href="#">SE-134</a>

### NOTE:

- The climate controlled seat blower keep low speed for approximately 60 seconds turning the switch.
- The climate controlled seat system is downed when the temperature sensor set as the seat cushion and the seatback's thermal electric device machine detects 20 °C (68°F) or more of mutual differences of temperature.

## Preliminary Check

NIS0027N

### 1. CHECK DUCT AND FILTER

Check the following.

- Is that there no foreign body in the blower motor filter.
- Is that there no foreign body in the duct.

OK or NG

OK >> Preliminary check is OK.

NG >> The foreign body is removed.

# CLIMATE CONTROLLED SEAT

## Check Climate Controlled Seat Control Unit Power Supply Circuit

NIS0027P

### 1. CHECK FUSE

Check 10A fuse [No. 12, located in fuse block (J/B)]

**NOTE:**

Refer to [SE-114, "Component Parts and Harness Connector Location"](#) .

OK or NG

OK >> GO TO 2.

NG >> If fuse is blown, be sure to eliminate cause of malfunction before installing new fuse, refer to [PG-3, "POWER SUPPLY ROUTING CIRCUIT"](#) .

### 2. CHECK CLIMATE CONTROLLED SEAT RELAY POWER SUPPLY CIRCUIT

1. Disconnect climate controlled seat relay connector.
2. Turn ignition switch ON.
3. Check voltage between climate controlled seat relay harness connector and ground.

Terminal		Voltage (V) (Approx.)
(+)	(-)	
Climate controlled seat relay connector	Terminal	
E16	2	Battery voltage

OK or NG

OK >> GO TO 3.

NG >> Repair or replace harness between fuse block (J/B) and climate controlled seat relay.

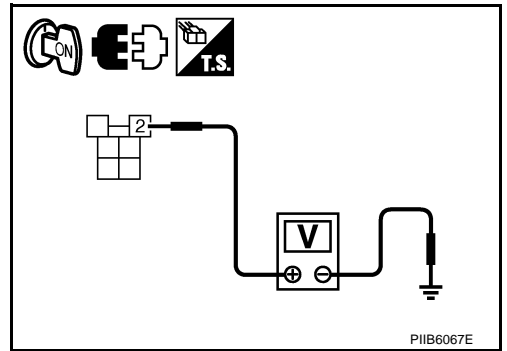

### 3. CHECK CLIMATE CONTROLLED SEAT RELAY

Check continuity climate controlled seat relay.

Climate controlled seat relay connector	Terminal		Condition	Continuity
E16	3	5	12V direct current supply between terminals 1 and 2	Yes
			No current supply	No
	6	7	12V direct current supply between terminals 1 and 2	Yes
			No current supply	No

OK or NG

OK >> GO TO 4.

NG >> Replace climate controlled seat relay.

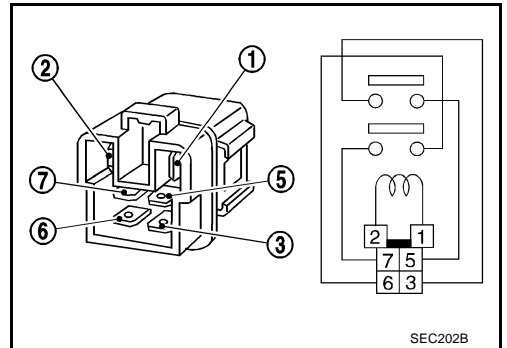

# CLIMATE CONTROLLED SEAT

## 4. CHECK CLIMATE CONTROLLED SEAT RELAY GROUND CIRCUIT

1. Turn ignition switch OFF.
2. Check continuity between climate controlled seat relay connector and ground.

Terminal			Continuity
Climate controlled seat relay connector	Terminal	Ground	
E16	1		Yes

### OK or NG

- OK >> Check the condition of the harness and connector.  
 NG >> Repair or replace harness between climate controlled seat relay and ground.

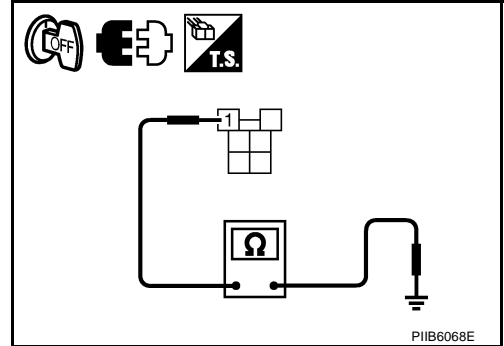

## Check Climate Controlled Seat Control Unit Power Supply and Ground Circuit

NIS0027Q

### 1. CHECK CLIMATE CONTROLLED SEAT CONTROL UNIT POWER SUPPLY CIRCUIT

1. Disconnect climate controlled seat control unit connector.
2. Turn ignition switch ON.
3. Check voltage between climate controlled seat control unit connector and ground.

Terminal			Voltage (V) (Approx.)
(+)	Terminal	(-)	
Climate controlled seat control unit connector			
B284 (driver side)	2	Ground	Battery voltage
B294 (passenger side)	4		

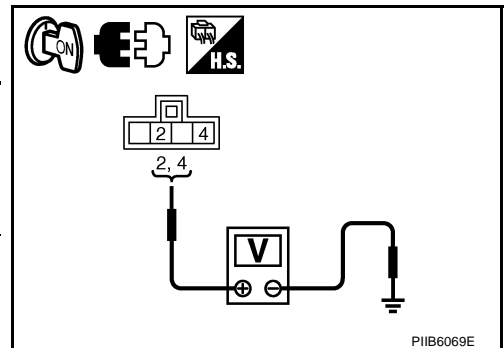

### OK or NG

- OK >> GO TO 6.  
 NG >> GO TO 2.

## 2. CHECK FUSE

- Check 15A fuse [No. 42, located in fuse, fusible link and relay unit] (Driver side)
- Check 15A fuse [No. 41, located in fuse, fusible link and relay unit] (Passenger side)

### NOTE:

Refer to [SE-114, "Component Parts and Harness Connector Location"](#) .

### OK or NG

- OK >> GO TO 3.  
 NG >> If fuse is blown, be sure to eliminate cause of malfunction before installing new fuse, refer to [PG-3, "POWER SUPPLY ROUTING CIRCUIT"](#) .



# CLIMATE CONTROLLED SEAT

## 3. CHECK CLIMATE CONTROLLED SEAT RELAY POWER SUPPLY CIRCUIT

1. Turn ignition switch OFF.
2. Disconnect climate controlled seat relay.
3. Check voltage between climate controlled seat relay connector and ground.

Terminal		(-)	Voltage (V) (Approx.)
(+)			
Climate controlled seat relay connector	Terminal		
E16	5	Ground	Battery voltage
	7		

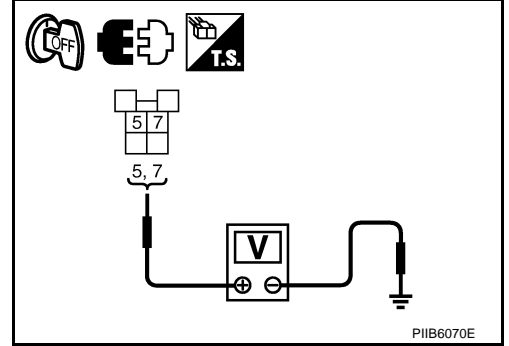

OK or NG

OK >> GO TO 4.

NG >> Repair or replace harness between climate controlled seat relay and ground.

## 4. CHECK CLIMATE CONTROLLED SEAT RELAY

Check continuity climate controlled seat relay.

Climate controlled seat relay connector	Terminal		Condition	Continuity
E16	3	5	12V direct current supply between terminals 1 and 2	Yes
			No current supply	No
	6	7	12V direct current supply between terminals 1 and 2	Yes
			No current supply	No

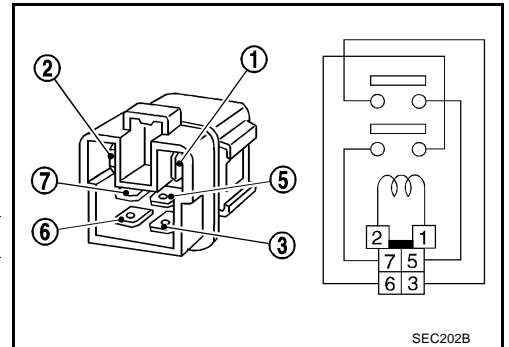

OK or NG

OK >> GO TO 5.

NG >> Replace climate controlled seat relay.

# CLIMATE CONTROLLED SEAT

## 5. CHECK CLIMATE CONTROLLED SEAT CONTROL UNIT HARNESS CIRCUIT

1. Check continuity between climate controlled seat control unit connector and climate controlled seat relay connector.

A		B		Continuity	
Climate controlled seat control unit connector	Terminal	Climate controlled seat relay connector	Terminal		
B284 (driver side)	2	E16	6	Yes	
	4		3		
B294 (passenger side)	2				
	4				

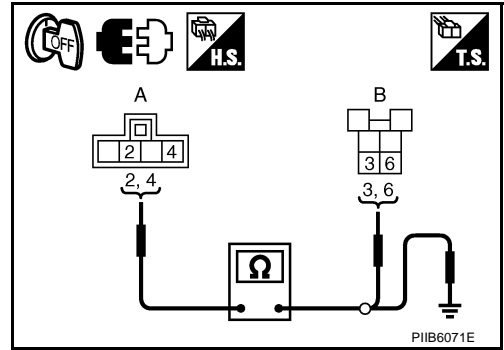

2. Check continuity between climate controlled seat control unit connector and ground.

A		Ground	Continuity
Climate controlled seat control unit connector	Terminal		
B284 (driver side) B294 (passenger side)	2 4		No

**OK or NG**

OK >> Check the condition of the harness and connector.

NG >> Repair or replace harness between climate controlled seat control unit and climate controlled seat relay.

## 6. CHECK CLIMATE CONTROLLED SEAT CONTROL UNIT GROUND CIRCUIT

Check continuity between climate controlled seat control unit connector and ground.

Terminal		Ground	Continuity
Climate controlled seat control unit connector	Terminal		
B284 (driver side) B294 (passenger side)	3		Yes

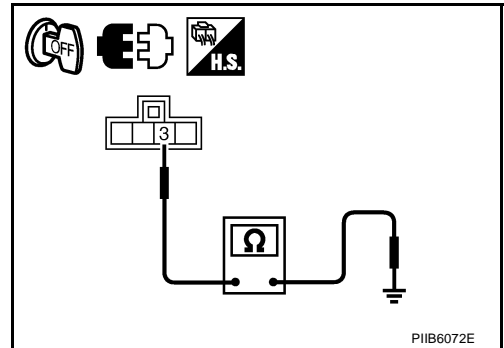

**OK or NG**

OK >> Climate controlled seat control unit power supply and ground circuit is OK.

NG >> Repair or replace harness between climate controlled seat control unit and ground.

# CLIMATE CONTROLLED SEAT

## Check Climate Controlled Seat Switch Power Supply Circuit

NIS0027R

### 1. CHECK CLIMATE CONTROLLED SEAT CONTROL UNIT POWER SUPPLY

1. Turn ignition switch ON.
2. Check voltage between climate controlled seat control unit and ground.

Terminal (+)		Terminal (-)	Voltage (V) (Approx.)
Climate controlled seat control unit connector	Terminal		
B283 (driver side) B293 (passenger side)	11	Ground	Battery voltage

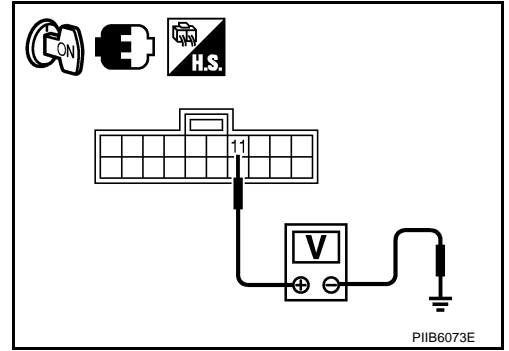

OK or NG

- OK >> GO TO 2.
- NG >> Replace climate controlled seat control unit.

### 2. CHECK CLIMATE CONTROLLED SEAT SWITCH POWER SUPPLY

1. Turn ignition switch OFF.
2. Disconnect climate controlled seat control unit and climate controlled seat switch connector.
3. Check continuity between climate controlled seat control unit connector and climate controlled seat switch connector.
  - Driver side

A		B		Continuity
Climate controlled seat control unit connector	Terminal	Climate controlled seat switch connector	Terminal	
B283	11	B430	1	Yes

- Passenger side

A		C		Continuity
Climate controlled seat control unit connector	Terminal	Climate controlled seat switch connector	Terminal	
B293	11	B429	1	Yes

4. Check continuity between climate controlled seat control unit connector and ground.

A		Ground	Continuity
Climate controlled seat control unit connector	Terminal		
B283 (driver side) B293 (passenger side)	11		No

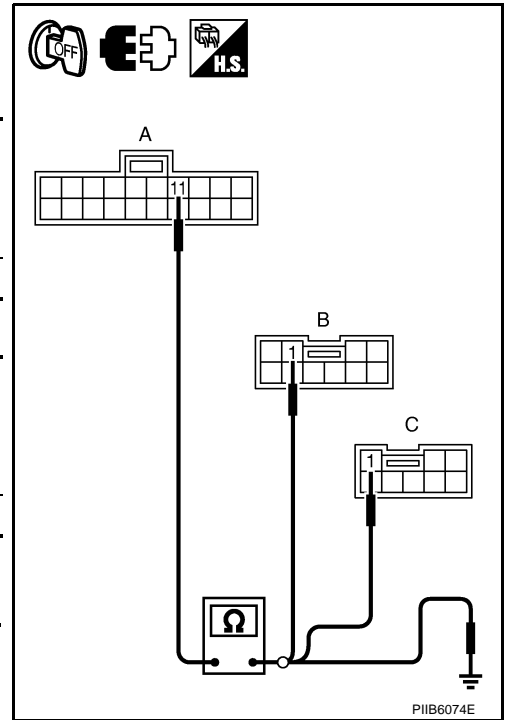

OK or NG

- OK >> Climate controlled seat control unit power supply circuit is OK.
- NG >> Repair or replace harness between climate controlled seat control unit and climate controlled seat switch.

# CLIMATE CONTROLLED SEAT

NIS0027S

## Check Climate Controlled Seat Switch Circuit

### 1. CHECK CLIMATE CONTROLLED SEAT SWITCH

1. Turn ignition switch OFF.
2. Disconnect climate controlled seat switch connector.
3. Check continuity between climate controlled seat switch.

Climate controlled seat switch connector	Terminal	Condition		Continuity	
B430 (driver side) B429 (passenger side)	1	3	Climate controlled seat switch	HEAT	Yes
			Other than above.		No
	2	3	Climate controlled seat switch	COOL	Yes
			Other than above.		No

\*: Driver side

#### OK or NG

OK >> GO TO 2.

NG >> Replace climate controlled seat switch.

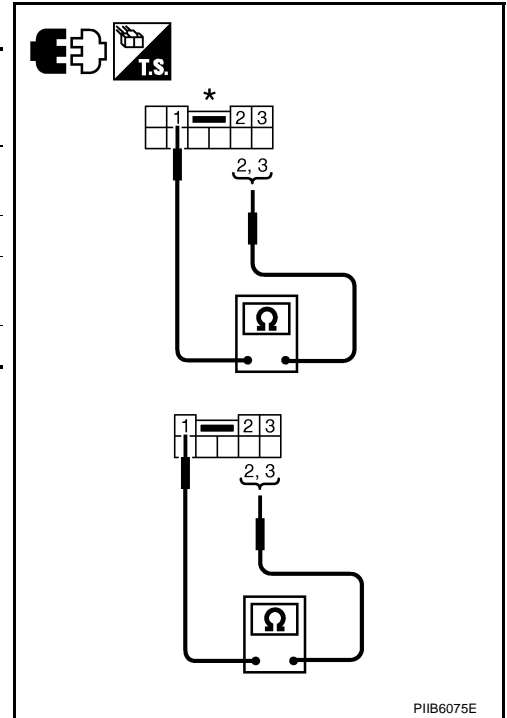

PIIB6075E

# CLIMATE CONTROLLED SEAT

## 2. CHECK CLIMATE CONTROLLED SEAT SWITCH HARNESS CIRCUIT

1. Disconnect climate controlled seat control unit connector.
  2. Check continuity between climate controlled seat control unit connector and climate controlled seat switch connector.
- Driver side

A		B		Continuity
Climate controlled seat control unit connector	Terminal	Climate controlled seat switch connector	Terminal	
B283	10	B430	3	Yes
	20		2	

- Passenger side

A		C		Continuity
Climate controlled seat control unit connector	Terminal	Climate controlled seat switch connector	Terminal	
B293	10	B429	3	Yes
	20		2	

3. Check continuity between climate controlled seat control unit connector and ground.

A		Ground	Continuity
Climate controlled seat control unit connector	Terminal		
B283 (driver side)	10		No
B293 (passenger side)	20		

OK or NG

- OK >> Replace climate controlled seat control unit.  
 NG >> Repair or replace harness between climate controlled seat control unit and climate controlled seat switch.

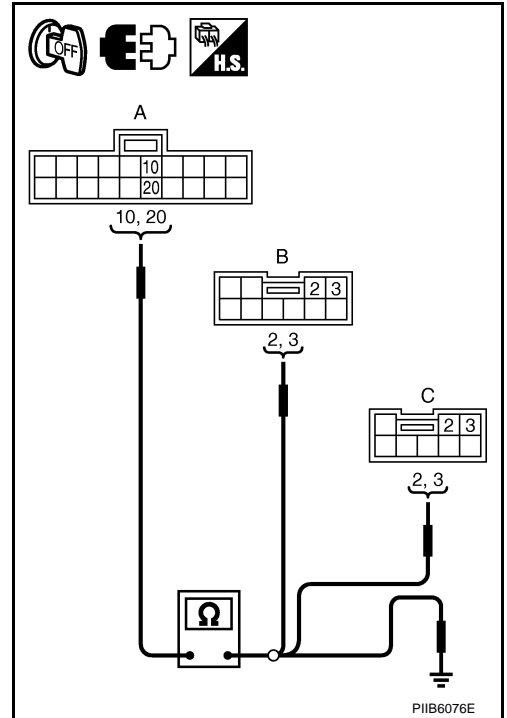

A  
B  
C  
D  
E  
F  
G  
H

SE

J  
K  
L  
M

# CLIMATE CONTROLLED SEAT

## Check Climate Controlled Seat Switch Indicator Circuit

NIS0027T

### 1. CHECK CLIMATE CONTROLLED SEAT CONTROL UNIT CIRCUIT

1. Turn ignition switch ON.
2. Check voltage between climate controlled seat switch connector and ground.

Terminal (+)		Terminal (-)	Condition		Voltage (V) (Approx.)
Climate controlled seat control unit connector	Terminal				
B283 (driver side) B293 (passenger side)	8	Ground	Climate controlled seat switch	HEAT	Battery voltage
			Other than above.		0
9	Climate controlled seat switch		COOL	Battery voltage	
	Other than above.		0		

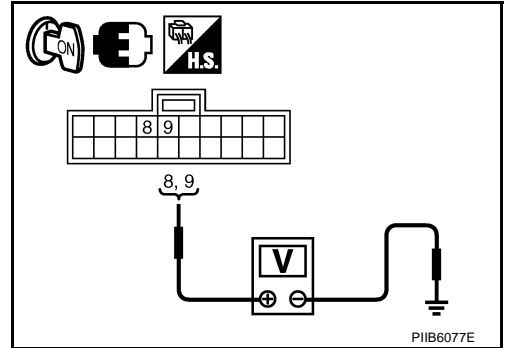

#### OK or NG

- OK >> GO TO 2.  
 NG >> Replace climate controlled seat control unit.

# CLIMATE CONTROLLED SEAT

## 2. CHECK CLIMATE CONTROLLED SEAT SWITCH HARNESS CURCUIT

1. Turn ignition switch OFF.
2. Disconnect climate controlled seat switch and climate controlled seat control unit connector.
3. Check continuity between climate controlled seat control unit connector and climate controlled seat switch.
  - Driver side

A		B		Continuity
Climate controlled seat control unit connector	Terminal	Climate controlled seat switch connector	Terminal	
B283	8	B430	5	Yes
	9		4	

- Passenger side

A		C		Continuity
Climate controlled seat control unit connector	Terminal	Climate controlled seat switch connector	Terminal	
B293	8	B429	5	Yes
	9		4	

4. Check continuity between climate controlled seat control unit connector and ground.

A		Ground	Continuity
Climate controlled seat control unit connector	Terminal		
B283 (driver side) B293 (passenger side)	8		No
	9		

OK or NG

OK >> GO TO 3.

NG >> Repair or replace harness between climate controlled seat control unit and climate controlled seat switch.

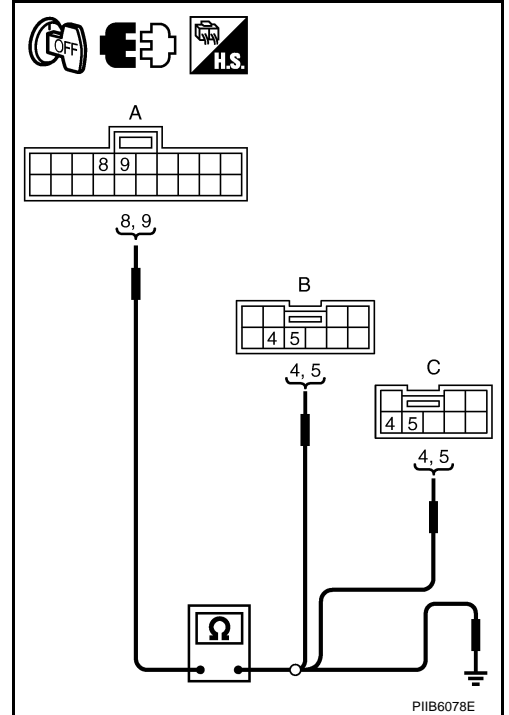

A  
B  
C  
D  
E  
F  
G  
H  
SE  
J  
K  
L  
M

# CLIMATE CONTROLLED SEAT

## 3. CHECK CLIMATE CONTROLLED SEAT SWITCH INDICATOR

Check continuity between climate controlled seat switch.

Climate controlled seat switch connector	Terminal		Continuity
	(+)	(-)	
B430 (driver side) B429 (passenger side)	4	6	No
	5		
	6	4	Yes
		5	

\*: Driver side

**OK or NG**

- OK >> Check the condition of the harness and the connector.  
 NG >> Replace climate controlled seat switch.

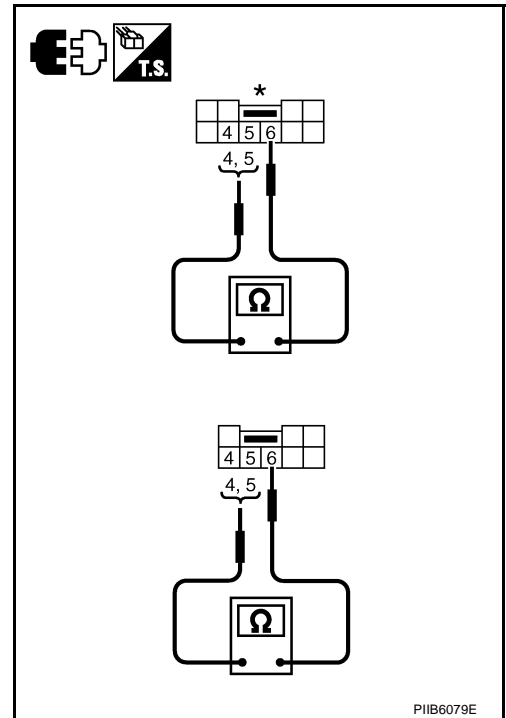

## Check Seat Cushion Thermal Electric Device Circuit

NIS0027U

### 1. CHECK SEAT CUSHION THERMAL ELECTRIC DEVICE POWER SUPPLY CIRCUIT

- Turn ignition switch ON.
- Check voltage between climate controlled seat control unit connector and ground.

Terminal (+)		Terminal (-)	Condition		Voltage (V) (Approx.)
Climate controlled seat control unit connector	Terminal		Climate controlled seat switch	HEAT or COOL	
B283 (driver side) B293 (passenger side)	5	Ground	Climate controlled seat switch	HEAT or COOL	0 - Battery voltage
			Other than above.		0
6	Climate controlled seat switch		COOL or HEAT	0 - Battery voltage	
	Other than above.			0	

**OK or NG**

- OK >> Seat cushion thermal electric device circuit is OK.  
 NG >> GO TO 2.

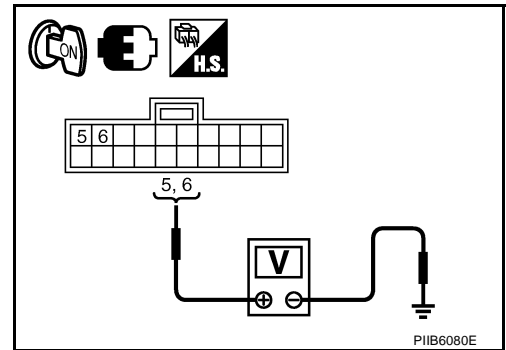



# CLIMATE CONTROLLED SEAT

## 2. CHECK SEAT CUSHION THERMAL ELECTRIC DEVICE HARNESS

1. Turn ignition switch OFF.
2. Disconnect climate controlled seat control unit connector and seat cushion thermal electric device connector.
3. Check continuity between climate controlled seat control unit connector and seat cushion thermal electric device connector.

A		B		Continuity
Climate controlled seat control unit connector	Terminal	Seat cushion thermal electric device connector	Terminal	
B283 (driver side)	5	B285 (driver side)	4	Yes
B293 (passenger side)	6	B295 (passenger side)	6	

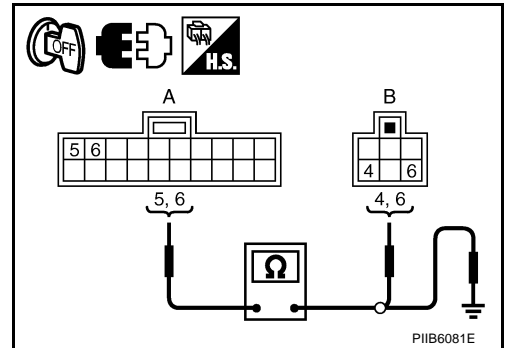

4. Check continuity between climate controlled seat control unit connector and ground.

A		Ground	Continuity
Climate controlled seat control unit connector	Terminal		
B283 (driver side)	5	Ground	No
B293 (passenger side)	6		

### OK or NG

OK >> Check the condition of the harness and the connector.

NG >> Repair or replace harness between climate controlled seat control unit and seat cushion thermal electric device.

## Check Seatback Thermal Electric Device Circuit

NIS0027V

### 1. CHECK SEATBACK THERMAL ELECTRIC DEVICE POWER SUPPLY CIRCUIT

1. Turn ignition switch ON.
2. Check voltage between climate controlled seat control unit connector and ground.

Terminal (+)		Terminal (-)	Condition		Voltage (V) (Approx.)
Climate controlled seat control unit connector	Terminal		Climate controlled seat switch	HEAT or COOL	
B283 (driver side) B293 (passenger side)	15	Ground	Climate controlled seat switch	HEAT or COOL	0 - Battery voltage
	16		Other than above.		0
15			Climate controlled seat switch	COOL or HEAT	0 - Battery voltage
	16		Other than above.		0

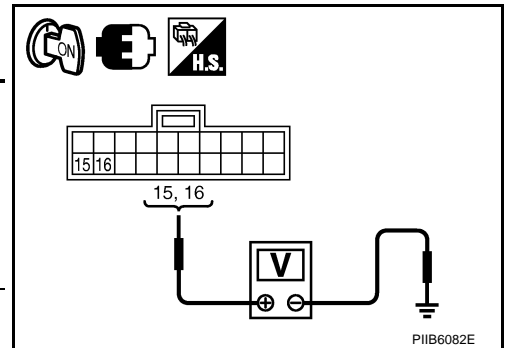

### OK or NG

OK >> Seatback thermal electric device circuit is OK.

NG >> GO TO 2.

# CLIMATE CONTROLLED SEAT

## 2. CHECK SEATBACK THERMAL ELECTRIC DEVICE HARNESS

1. Turn ignition switch OFF.
2. Disconnect climate controlled seat control unit connector and seatback thermal electric device connector.
3. Check continuity between climate controlled seat control unit connector and seatback thermal electric device connector.

A		B		Continuity
Climate controlled seat control unit connector	Terminal	Seatback thermal electric device connector	Terminal	
B283 (driver side)	15	B285 (driver side)	4	Yes
B293 (passenger side)	16	B295 (passenger side)	6	

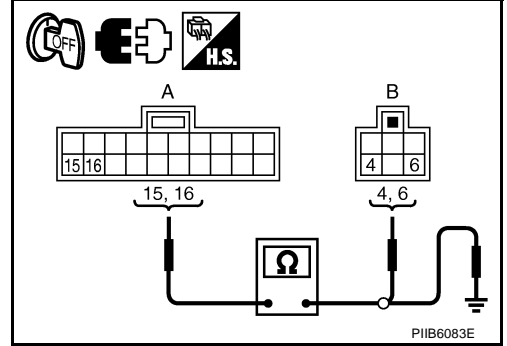

4. Check continuity between climate controlled seat control unit connector and ground.

A		Ground	Continuity
Climate controlled seat control unit connector	Terminal		
B283 (driver side)	15	Ground	No
B293 (passenger side)	16		

### OK or NG

- OK >> Check the condition of the harness and the connector.  
 NG >> Repair or replace harness between climate controlled seat control unit and seatback thermal electric device.

## Check Seat Cushion Thermal Electric Device Sensor Circuit

NIS0027W

### 1. CHECK CLIMATE CONTROLLED SEAT CONTROL UNIT CIRCUIT

1. Turn ignition switch ON.
2. Check voltage between climate controlled seat control unit connector and ground.

Terminal (+)		Terminal (-)	Condition	Voltage (V) (Approx.)
Climate controlled seat control unit connector	Terminal			
B283 (driver side)	22	Ground	Blower motor operated	0.5 - 4
B293 (passenger side)				

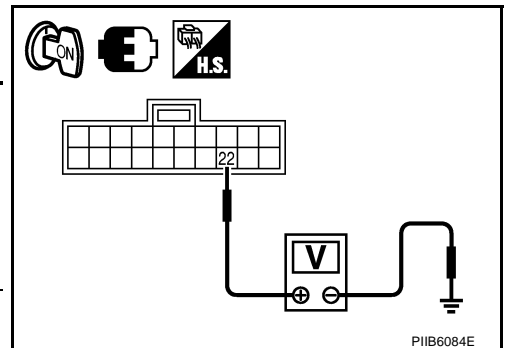

### OK or NG

- OK >> Climate controlled seat control unit circuit is OK.  
 NG >> GO TO 2.

# CLIMATE CONTROLLED SEAT

## 2. CHECK SEAT CUSHION THERMAL ELECTRIC DEVICE SENSOR HARNESS

1. Turn ignition switch OFF.
2. Disconnect climate controlled seat control unit connector and seat cushion thermal electric device connector.
3. Check continuity between climate controlled seat control unit connector and seat cushion thermal electric device connector.

A		B		Continuity
Climate controlled seat control unit connector	Terminal	Seat cushion thermal electric device connector	Terminal	
B283 (driver side)	21	B285 (driver side)	2	Yes
B293 (passenger side)	22	B295 (passenger side)	1	

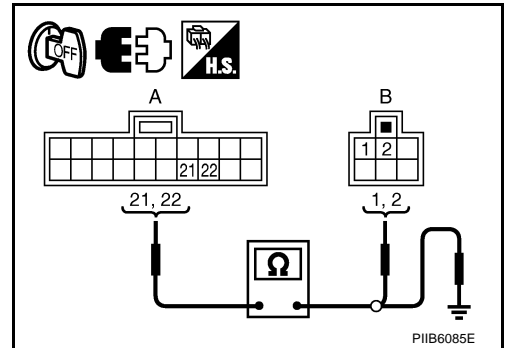

4. Check continuity between climate controlled seat control unit connector and ground.

A		Ground	Continuity
Climate controlled seat control unit connector	Terminal		
B283 (driver side)	21	No	
B293 (passenger side)	22		

### OK or NG

OK >> GO TO 3.

NG >> Repair or replace harness between climate controlled seat control unit and seat cushion thermal electric device.

## 3. CHECK SEAT CUSHION THERMAL ELECTRIC DEVICE SENSOR

Check resistance between seat cushion thermal electric device connector.

Seat cushion thermal electric device connector	Terminal		Resistance (K $\Omega$ ) (Approx.)
B220 (driver side) B258 (passenger side)	1	2	2

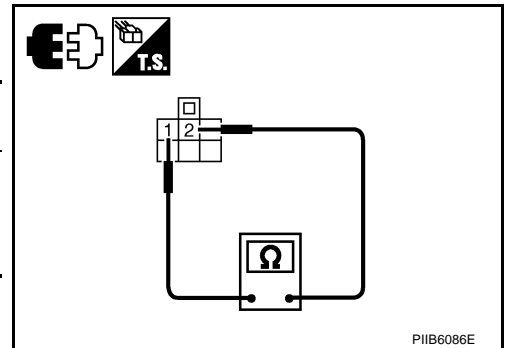

### OK or NG

OK >> Check the condition of the harness and the connector.

NG >> Replace seat cushion thermal electric device.

# CLIMATE CONTROLLED SEAT

## Check Seatback Thermal Electric Device Sensor Circuit

NIS0027X

### 1. CHECK CLIMATE CONTROLLED SEAT CONTROL UNIT CIRCUIT

1. Turn ignition switch ON.
2. Check voltage between climate controlled seat control unit connector and ground.

Terminal (+)		Terminal (-)	Condition	Voltage (V) (Approx.)
Climate controlled seat control unit connector	Terminal			
B283 (driver side) B293 (passenger side)	23	Ground	Blower motor operated	0.5 - 4

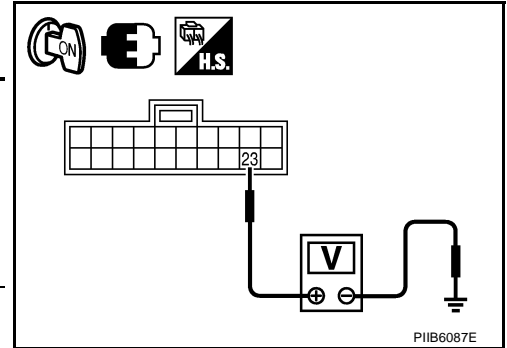

#### OK or NG

- OK >> Climate controlled seat control unit circuit is OK.  
 NG >> GO TO 2.

### 2. CHECK SEATBACK THERMAL ELECTRIC DEVICE SENSOR HARNESS

1. Turn ignition switch OFF.
2. Disconnect climate controlled seat control unit connector and seatback thermal electric device connector.
3. Check continuity between climate controlled seat control unit connector and seatback thermal electric device connector.

A		B		Continuity
Climate controlled seat control unit connector	Terminal	Seatback thermal electric device connector	Terminal	
B283 (driver side) B293 (passenger side)	23	B220 (driver side) B258 (passenger side)	1	Yes
	24		2	

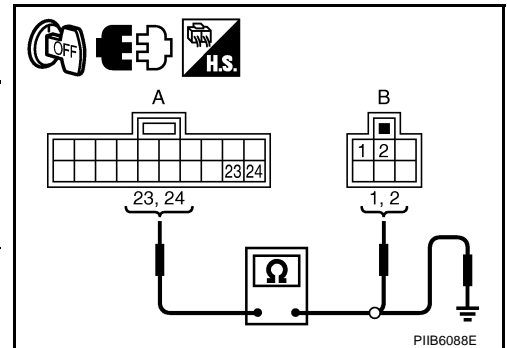

4. Check continuity between climate controlled seat control unit connector and ground.

A		Ground	Continuity
Climate controlled seat control unit connector	Terminal		
B283 (driver side) B293 (passenger side)	23		No
	24		

#### OK or NG

- OK >> GO TO 3.  
 NG >> Repair or replace harness between climate seat control unit and seatback thermal electric device.

# CLIMATE CONTROLLED SEAT

## 3. CHECK SEATBACK THERMAL ELECTRIC DEVICE SENSOR

Check resistance between seatback thermal electric device connector.

Seatback thermal electric device connector	Terminal		Resistance (KΩ) (Approx.)
	1	2	
B220 (driver side) B258 (passenger side)	1	2	2

OK or NG

- OK >> Check the condition of the harness and the connector.
- NG >> Replace seatback thermal electric device.

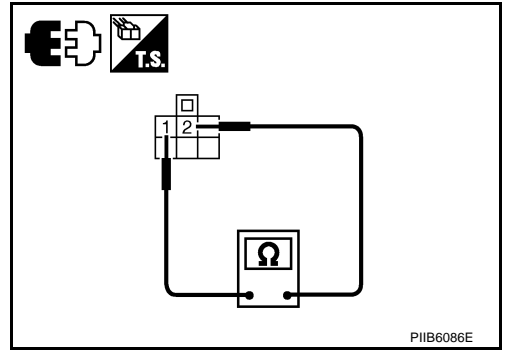

## Check Climate Controlled Seat Blower Motor Circuit

NIS0027Y

### 1. CHECK CLIMATE CONTROLLED SEAT BLOWER MOTOR CIRCUIT HARNESS

1. Turn ignition switch OFF.
2. Disconnect climate controlled seat control unit and climate controlled seat blower motor connector.
3. Check continuity between climate controlled seat control unit connector and climate controlled seat blower motor connector.

A		B		Continuity
Climate controlled seat control unit connector	Terminal	Climate controlled seat blower motor connector	Terminal	
B283 (driver side) B293 (passenger side)	7	B282 (driver side) B292 (passenger side)	3	Yes
	14		2	
	17		4	
	18		1	

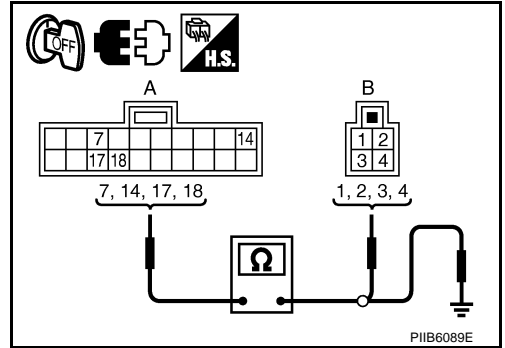

4. Check continuity between climate controlled seat control unit connector and ground.

A		Ground	Continuity
Climate controlled seat control unit connector	Terminal		
B283 (driver side) B293 (passenger side)	7	No	
	14		
	17		
	18		

OK or NG

- OK >> GO TO 2.
- NG >> Repair or replace harness between climate controlled seat control unit and climate controlled seat blower motor.

# CLIMATE CONTROLLED SEAT

## 2. CHECK CLIMATE CONTROLLED SEAT BLOWER MOTOR POWER SUPPLY CIRCUIT

1. Connect climate controlled seat control unit connector and blower motor connector.
2. Turn ignition switch ON.
3. Check voltage between climate controlled seat control unit connector and ground.

Terminal			Voltage (V) (Approx.)
(+)		(-)	
Climate controlled seat control unit connector	Terminal		
B283 (driver side) B293 (passenger side)	14	Ground	Battery voltage

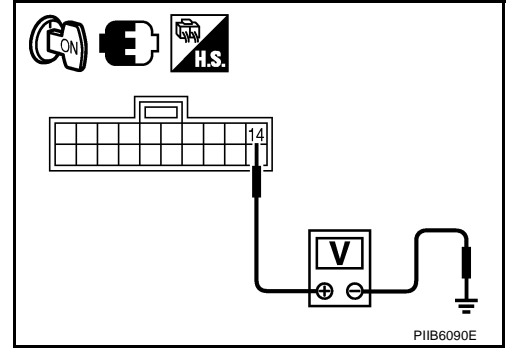

### OK or NG

- OK >> GO TO 3.  
NG >> Replace climate controlled seat control unit.

## 3. CHECK CLIMATE CONTROLLED SEAT BLOWER MOTOR SPEED CONTROL SIGNAL CIRCUIT

Check voltage between climate controlled seat control unit connector and ground.

Terminal			Condition	Voltage (V) (Approx.)
(+)		(-)		
Climate controlled seat control unit connector	Terminal			
B283 (driver side) B293 (passenger side)	17	Ground	Climate controlled seat switch HEAT or COOL	4.5 - 8.0
			Other than above.	0

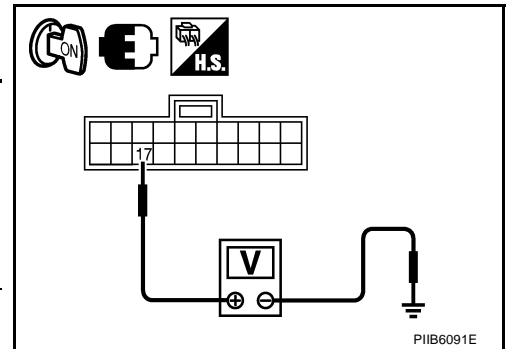

### OK or NG

- OK >> GO TO 4.  
NG >> Replace climate controlled seat control unit.

## 4. CHECK CLIMATE CONTROLLED SEAT BLOWER MOTOR TACHOMETER SIGNAL CIRCUIT

Check voltage between climate controlled seat control unit connector and ground.

Terminal			Condition	Voltage (V) (Approx.)
(+)		(-)		
Climate controlled seat control unit connector	Terminal			
B283 (driver side) B293 (passenger side)	18	Ground	Climate controlled seat switch HEAT or COOL	4.5 - 8.0
			Other than above.	Battery voltage

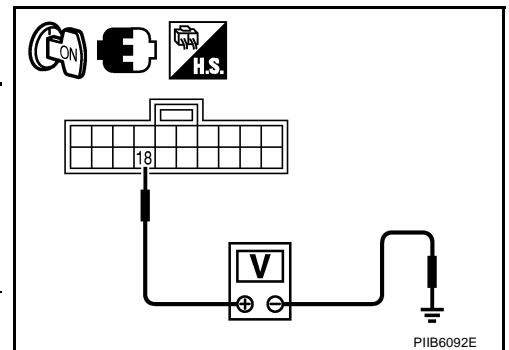

### OK or NG

- OK >> Climate controlled seat blower motor circuit is OK.  
NG >> Replace climate controlled seat blower motor.

# CLIMATE CONTROLLED SEAT

## Check Climate Controlled Seat Control Unit

NIS0027Z

### 1. CHECK THE CLIMATE CONTROLLED SEAT CONTROL UNIT

Does the heater operate normally when the driver side or passenger side climate controlled seat control unit is exchanged?

YES or NO

- YES >> Climate controlled seat control unit is OK.
- NO >> Replace climate controlled seat control unit.

A

B

C

D

E

F

G

H

SE

J

K

L

M

# HEATED SEAT

PF87335

## HEATED SEAT

### Component Parts and Harness Connector Location

NIS00280

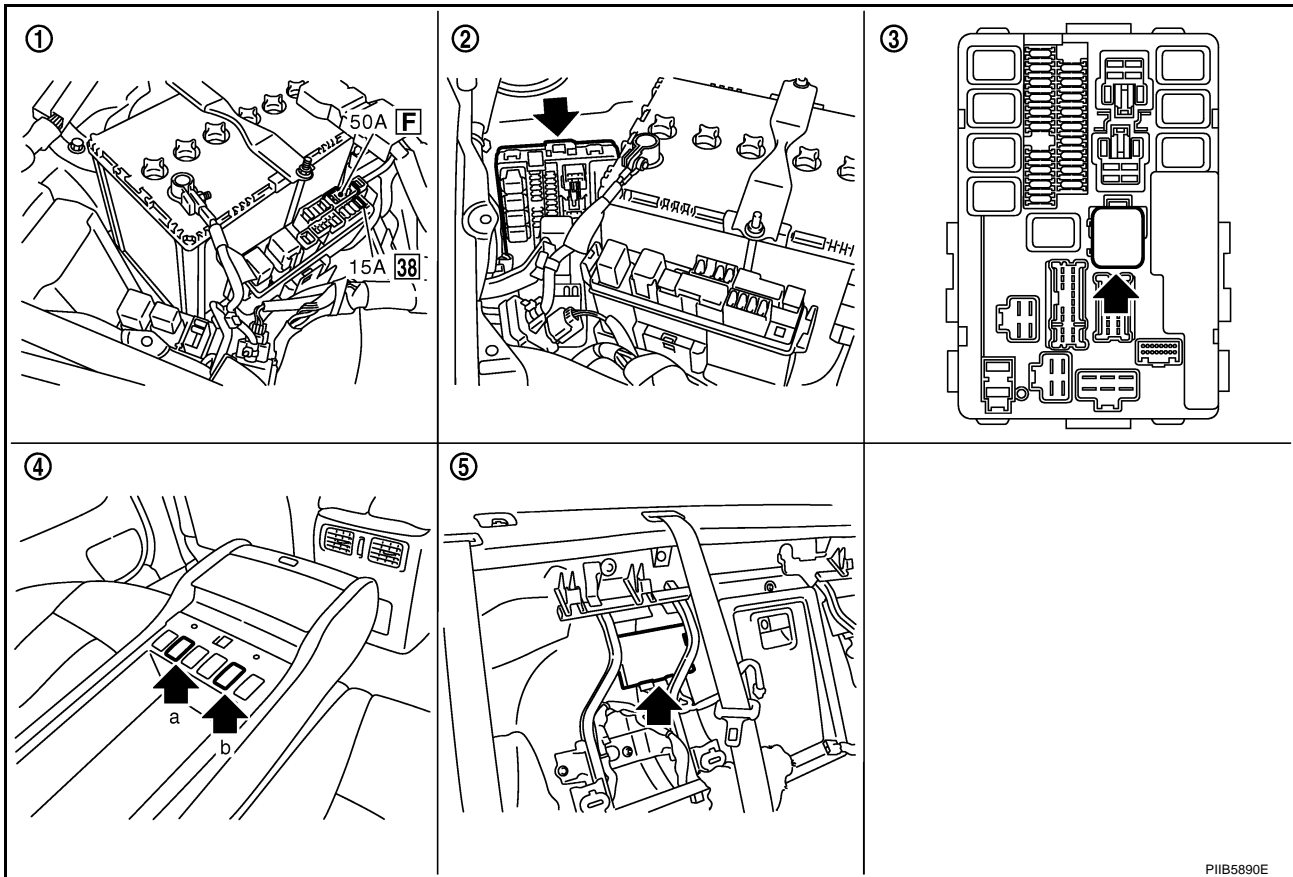

1. Fuse, fusible link and relay block (J/B)

2. IPDM E/R E5, E6, E9

3. Heated seat relay E5, E6, E9  
(Built into the IPDM E/R)

4. a: Rear heated seat switch LH B507  
b: Rear heated seat switch RH B558

5. Rear seat control unit  
B303, B304 (LH)  
B353, B354 (RH)  
(View with the rear seatback removed)

## System Description

NIS00281

### NOTE:

- When handling seat, be extremely careful not to scratch heating unit
- To replace heating unit, seat trim and pad should be separated.
- Do not use any organic solvent, such as thinner, benzene, alcohol, etc. to clean trims.

Power is all time supplied

- to rear LH seat control unit and rear RH seat control unit terminal 1.
- through 50A fusible link [Letter F, located in the fuse block (J/B)],
- to IPDM E/R (heated seat relay) terminal 14.
- through 15A fuse [No.38, located in the fuse block (J/B)].

With the ignition switch to ON or START position, power is supplied

- to rear LH seat control unit terminal 4 and
- to rear heated seat switch LH terminal 6.
- through IPDM E/R (heated seat relay) terminal 12
- to rear RH seat control unit terminal 4 and
- to rear heated seat switch RH terminal 6
- through IPDM E/R (heated seat relay) terminal 9.



## HEATED SEAT

When rear heated seat switch (LH, RH) is LOW position, ground is supplied

- to rear seat control unit terminal 18,
- through rear heated seat switch terminal 2,
- through rear heated seat switch terminal 3,
- through body grounds B5, B40 and B131

A

B

Then rear seat control unit recognizes that rear heated seat switch is LOW position.

When rear heated seat switch is LOW position, power is supplied

- through rear seat control unit terminal 6,
- through rear seat cushion heater terminal 2,
- through rear seat cushion heater terminal 3,
- to rear seatback heater terminal 1.

C

D

Then ground is supplied

- to rear seatback heater terminal 2.
- through body grounds B5, B40 and B131.

E

With power and ground supplied, rear heated seat is operated.

When rear heated seat switch is in LOW position, ground is supplied

- to rear heated seat switch terminal 5,
- through rear seat control unit terminal 14,
- through rear seat control unit terminal 13,
- through body grounds B5, B40 and B131.

F

G

With power and ground supplied, rear heated seat switch LOW position indicator is illuminated

When rear heated seat switch (LH, RH) is in HIGH position, ground is supplied

- to rear seat control unit terminal 17,
- through rear heated seat switch terminal 1,
- through rear heated seat switch terminal 3,
- through body grounds B5, B40 and B131

H

SE

Then rear seat control unit recognizes that rear heated seat switch is in HIGH position.

When rear heated seat switch is in HIGH position, power is supplied

- through rear seat control unit terminal 5,
- through rear seat cushion heater terminal 1,
- through rear seat cushion heater terminal 3,
- to rear seatback heater terminal 1.

J

K

Then ground is supplied

- to rear seatback heater terminal 2.
- through body grounds B5, B40 and B131.
- to rear seat cushion heater terminal 2,
- through rear seat control unit terminal 6,
- through rear seat control unit terminal 8,
- through body grounds B5, B40 and B131.

L

M

With power and ground supplied, rear heated seat generates heat more than the time of LOW position.

When rear heated seat switch is in HIGH position, ground is supplied

- to rear heated seat switch terminal 4,
- through rear seat control unit terminal 9,
- through rear seat control unit terminal 13,
- through body grounds B5, B40 and B131.

With power and ground supplied rear heated seat switch HIGH position indicator is illuminated.

# HEATED SEAT

## Schematic

NIS00282

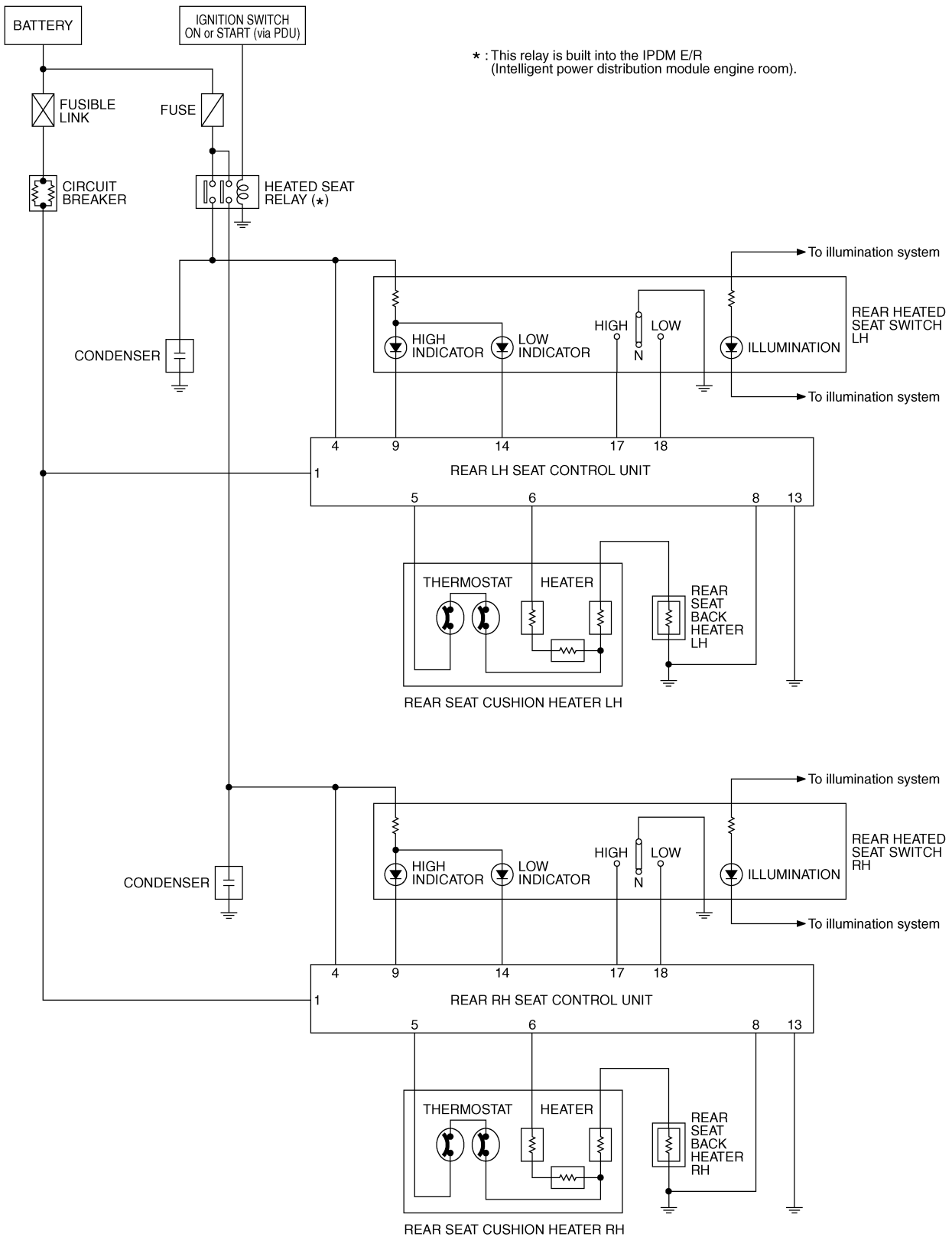

TIWT1397E

# HEATED SEAT

## Wiring Diagram — HSEAT —

NIS00283

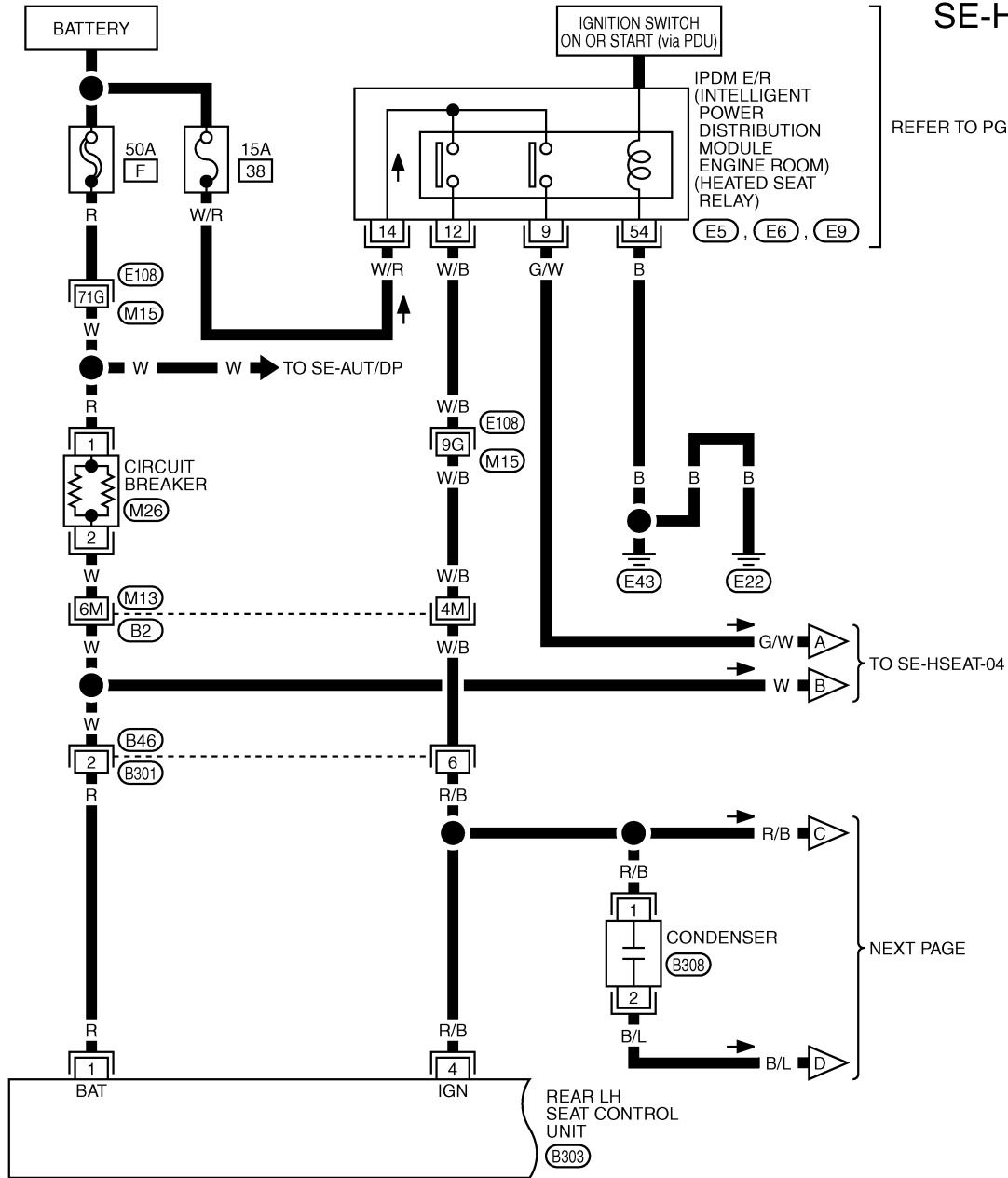

SE-HSEAT-01

REFER TO PG-POWER & PDU.

TO SE-HSEAT-04

NEXT PAGE

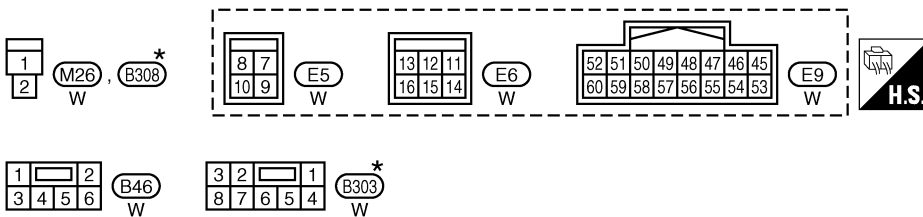

REFER TO THE FOLLOWING.  
 (E108), (B2) -SUPER MULTIPLE JUNCTION (SMJ)

\*: THIS CONNECTOR IS NOT SHOWN IN "HARNESS LAYOUT", PG SECTION.

A  
B  
C  
D  
E  
F  
G  
H  
SE  
J  
K  
L  
M

# HEATED SEAT

SE-HSEAT-02

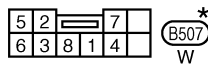
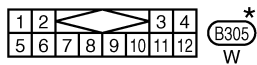
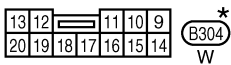
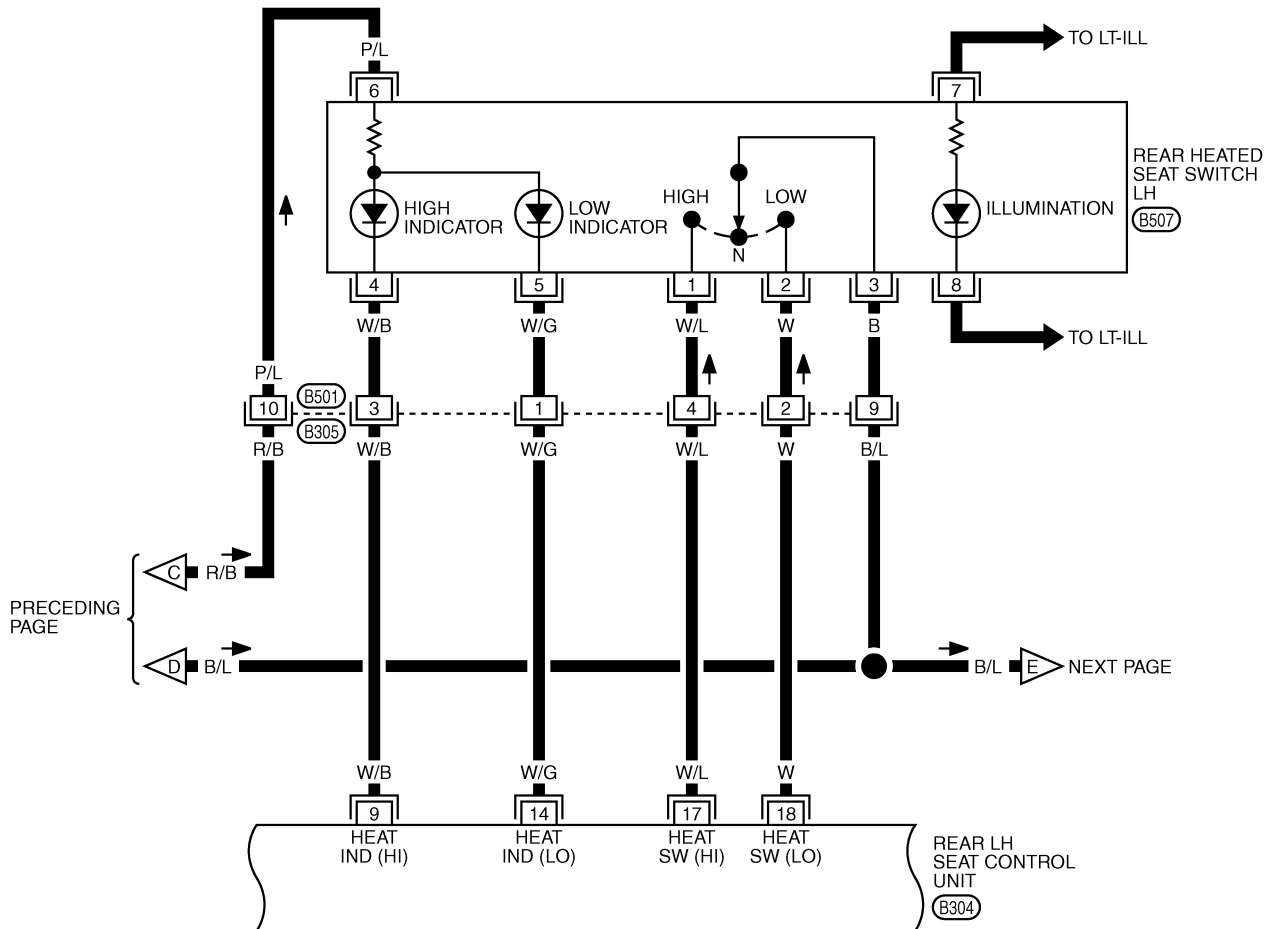

\*: THIS CONNECTOR IS NOT SHOWN IN "HARNESS LAYOUT", PG SECTION.

TIWT1399E

# HEATED SEAT

SE-HSEAT-03

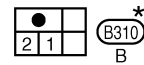
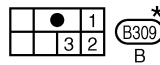
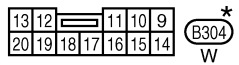
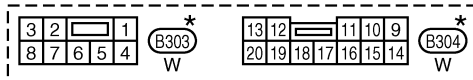
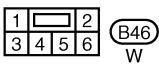
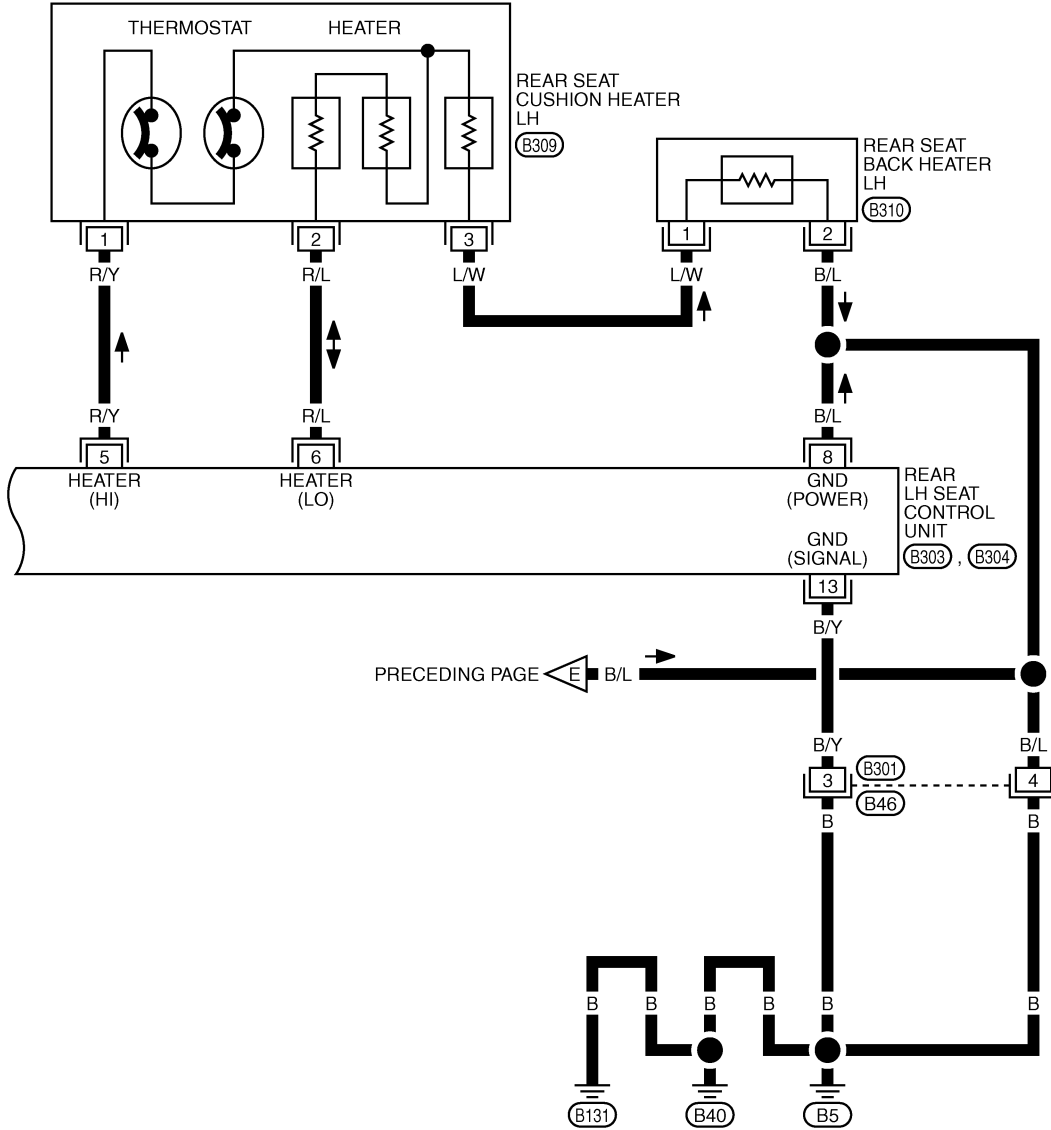

\*: THIS CONNECTOR IS NOT SHOWN IN "HARNES LAYOUT", PG SECTION.

TIWT1400E

# HEATED SEAT

SE-HSEAT-04

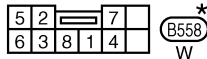
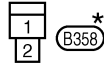
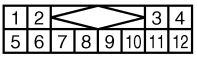
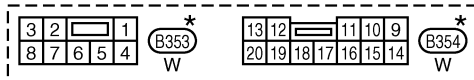
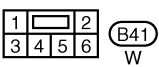
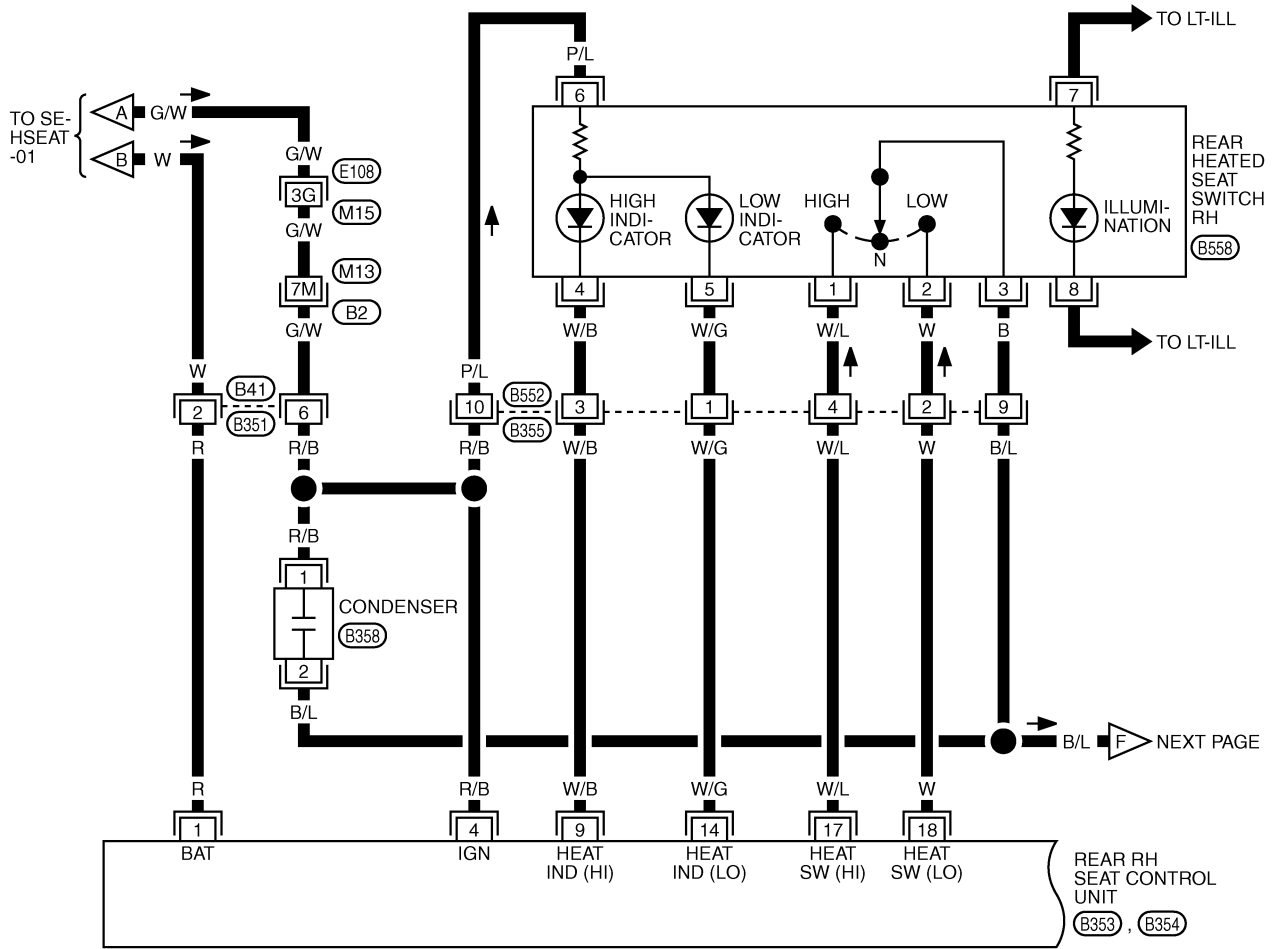

REFER TO THE FOLLOWING.  
 (E108), (B2) -SUPER MULTIPLE JUNCTION (SMJ)

\*: THIS CONNECTOR IS NOT SHOWN IN "HARNESS LAYOUT", PG SECTION.

TIWT1454E

# HEATED SEAT

SE-HSEAT-05

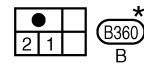
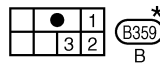
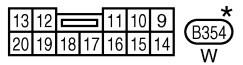
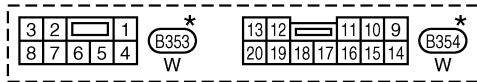
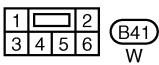
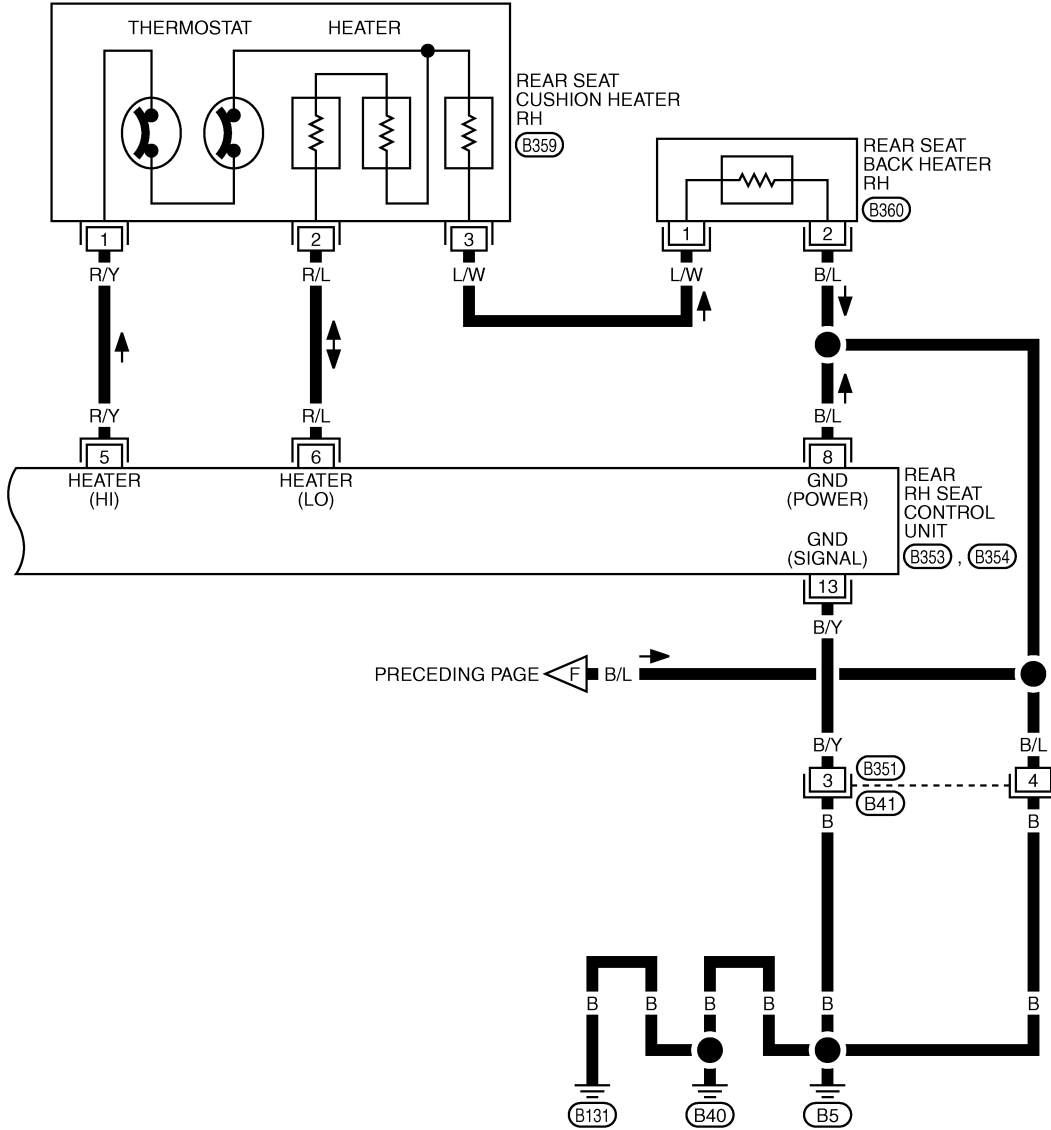

\*: THIS CONNECTOR IS NOT SHOWN IN "HARNESS LAYOUT", PG SECTION.

TIWT1402E

# HEATED SEAT

## Terminals and Reference Values for Rear Seat Control Unit

NIS00284

Terminal	Wire color	Item	Signal Input/Output	Condition	Voltage (V) (Approx.)
1	R	Power source (BAT)	Input	—	Battery voltage
4	R/B	Power source (IGN)	Input	—	Battery voltage
5	R/Y	Seat heater HI signal	Input	Seat heater HI operation	Battery voltage
				Other than above	0
6	R/L	Seat heater LO signal	Input	Seat heater LO operation	Battery voltage
				Other than above	0
8	B/L	Ground (power)	—	—	0
9	W/B	Heated seat indicator HI signal	Output	Heater HI operation (lit)	0
				Other than above	Battery voltage
13	B/Y	Ground (signal)	—	—	0
14	W/G	Heated seat indicator LO signal	Output	Heater LO operation (lit)	0
				Other than above	Battery voltage
17	W/L	Heated seat switch HI signal	Input	Heated seat switch (HI) – ON (pressed)	0
				Heated seat switch (HI) – OFF	Battery voltage
18	W	Heated seat switch LO signal	Input	Heated seat switch (LO) – ON (pressed)	0
				Heated seat switch (LO) – OFF	Battery voltage

## Work Flow

NIS00285

1. Check the symptom and customer's requests.
2. Understand the outline of system. Refer to [SE-144, "System Description"](#) .
3. According to the trouble diagnosis chart, repair or replace the cause of the malfunction. Refer to [SE-152, "Trouble Diagnoses Symptom Chart"](#) .
4. Does heated seat operate normally? YES: GO TO 5, NO: GO TO 3.
5. INSPECTION END.

## Trouble Diagnoses Symptom Chart

NIS00286

- Check that other systems using the signal of the following systems operate normally.

Symptom	Diagnoses / service procedure	Refer to page
Rear heated seat LH and RH does not operate.	Check rear heated seat power supply and ground circuit	<a href="#">SE-153</a>
Rear heated seat LH or RH do not operate.	1. Check rear seat control unit power supply and ground circuit	<a href="#">SE-154</a>
	2. Check rear heated seat switch circuit	<a href="#">SE-156</a>
	3. Check rear seatback heater circuit	<a href="#">SE-162</a>
	4. Replace rear LH or RH seat control unit	<a href="#">SE-144</a>
Rear heated seat do not operate with LO or HI position.	1. Check rear heated seat switch circuit	<a href="#">SE-156</a>
	2. Check rear heated seat circuit	<a href="#">SE-161</a>
Rear heated seat LH or RH indicator do not operate.	Check rear heated seat indicator power supply circuit	<a href="#">SE-158</a>
Rear heated seat indicator do not operate with LO or HI position	Check rear heated seat indicator circuit	<a href="#">SE-159</a>



# HEATED SEAT

NIS00287

## Check Rear Heated Seat Power Supply and Ground Circuit

### 1. CHECK FUSIBLE LINK AND FUSE

- Check 50A fusible link (letter F located in the fuse and fusible link box).
- Check 15A fuse (No.38, located in fuse block).
- Check circuit breaker.

#### NOTE:

Refer to [SE-144, "Component Parts and Harness Connector Location"](#) .

#### OK or NG

OK >> GO TO 2.

NG >> If fuse or circuit breaker is blown, be sure to eliminate cause of malfunction before installing new fuse or new circuit breaker, refer to [PG-3, "POWER SUPPLY ROUTING CIRCUIT"](#) .

### 2. CHECK HEATED SEAT RELAY POWER SUPPLY CIRCUIT

1. Turn ignition switch OFF.
2. Check voltage between IPDM E/R (heated seat relay) connector and ground.

Terminal (+)		Terminal (-)	Voltage (V) (Approx.)
IPDM E/R (heated seat relay) connector	Terminal		
E6	14	Ground	Battery voltage

#### OK or NG

OK >> GO TO 3.

NG >> Repair or replace harness between fuse block (J/B) and IPDM E/R (heated seat relay).

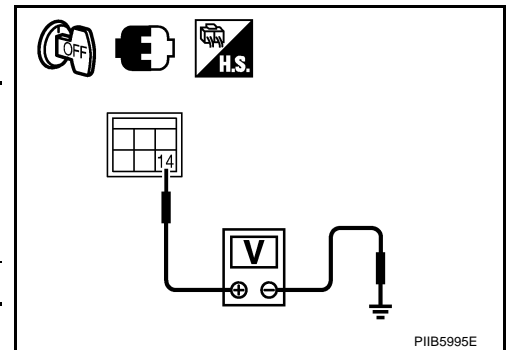

### 3. CHECK HEATED SEAT RELAY GROUND CIRCUIT

1. Disconnect IPDM E/R (heated seat relay) connector.
2. Check continuity between IPDM E/R (heated seat relay) connector and ground.

Terminal		Ground	Continuity
IPDM E/R (heated seat relay) connector	Terminal		
E9	54		Yes

#### OK or NG

OK >> Check the condition of the harness and connector.

NG >> Repair or replace harness between IPDM E/R (heated seat relay) and ground.

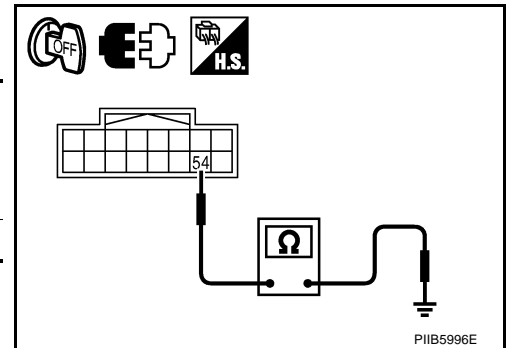

# HEATED SEAT

## Check Rear Seat Control Unit Power Supply and Ground Circuit

NIS00288

### 1. CHECK REAR SEAT CONTROL UNIT POWER SUPPLY CIRCUIT (BAT)

1. Turn ignition switch OFF.
2. Check voltage between rear seat control unit connector and ground.

Terminal		(-)	Voltage (V) (Approx.)
(+)			
Rear seat control unit connector	Terminal		
B303 (LH) B353 (RH)	1	Ground	Battery voltage

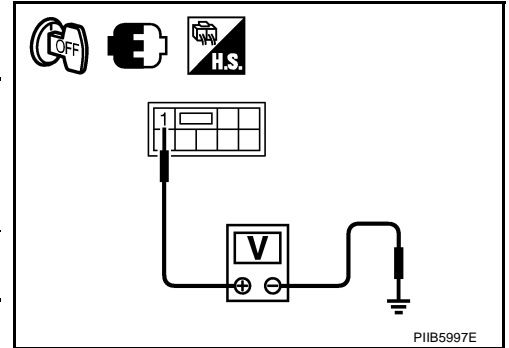

#### OK or NG

OK >> GO TO 2.

NG >> Repair or replace harness between circuit breaker and rear seat control unit.

### 2. CHECK REAR SEAT CONTROL UNIT POWER SUPPLY CIRCUIT (IGN)

1. Turn ignition switch ON.
2. Check voltage between rear seat control unit connector and ground.

Terminal		(-)	Voltage (V) (Approx.)
(+)			
Rear seat control unit connector	Terminal		
B303 (LH) B353 (RH)	4	Ground	Battery voltage

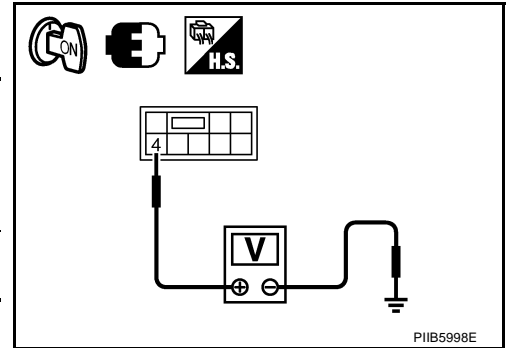

#### OK or NG

OK >> GO TO 4.

NG >> GO TO 3.

# HEATED SEAT

## 3. CHECK REAR SEAT CONTROL UNIT HARNESS

1. Turn ignition switch OFF.
2. Disconnect IPDM E/R (heated seat relay) and rear seat control unit connector.
3. Check continuity between IPDM E/R (heated seat relay) connector and rear seat control unit connector.

A		B		Continuity
Rear seat control unit connector	Terminal	IPDM E/R (heated seat relay) connector	Terminal	
B303 (LH)	4	E6	12	Yes
B353 (RH)		E5	9	

4. Check continuity between rear seat control unit connector and ground.

A		Ground	Continuity
Rear seat control unit connector	Terminal		
B303 (LH) B353 (RH)	4		No

**OK or NG**

OK >> GO TO 4.

NG >> Repair or replace harness between rear seat control unit and IPDM E/R (heated seat relay).

## 4. CHECK REAR SEAT CONTROL UNIT GROUND CIRCUIT

1. Turn ignition switch OFF.
2. Disconnect rear seat control unit connector.
3. Check continuity between rear seat control unit connector and ground.

Terminal		Ground	Continuity
Rear seat control unit connector	Terminal		
B303 (LH) B353 (RH)	8		Yes
B304 (LH) B354 (RH)	13		

**OK or NG**

OK >> Rear seat control unit power supply and ground circuit is OK.

NG >> Repair or replace harness between rear seat control unit and ground.

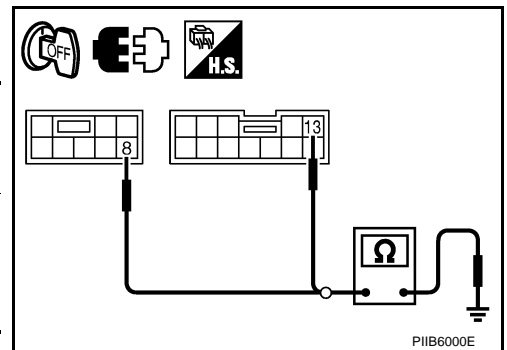
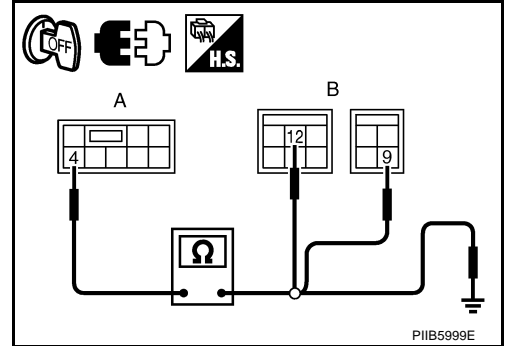

A  
B  
C  
D  
E  
F  
G  
H  
SE  
J  
K  
L  
M

# HEATED SEAT

NIS00289

## Check Rear Heated Seat Switch Circuit

### 1. CHECK REAR HEATED SEAT SWITCH POWER SUPPLY-1

1. Turn ignition switch ON.
2. Check voltage between rear seat control unit connector and ground.

Terminal (+)		Terminal (-)	Condition		Voltage (V) (Approx.)
Rear seat control unit connector	Terminal				
B304 (LH) B354 (RH)	17	Ground	Rear heated seat switch	HIGH	0
			Other than above.		5
18	Rear heated seat switch		LOW	0	
	Other than above.		5		

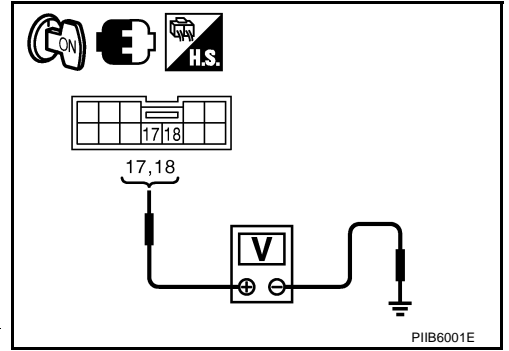

OK or NG

- OK >> Rear heated seat switch circuit is OK.  
 NG >> GO TO 2.

### 2. CHECK REAR HEATED SEAT SWITCH HARNESS

1. Turn ignition switch OFF.
2. Disconnect rear heated seat switch and rear seat control unit connector.
3. Check continuity between rear heated seat switch connector and rear seat control unit connector.

A		B		Continuity
Rear seat control unit connector	Terminal	Rear heated seat switch connector	Terminal	
B304 (LH) B354 (RH)	17	B507 (LH) B558 (RH)	1	Yes
	18		2	

4. Check continuity between rear seat control unit connector and ground.

A		Ground	Continuity
Rear seat control unit connector	Terminal		
B304 (LH) B354 (RH)	17		No
	18		

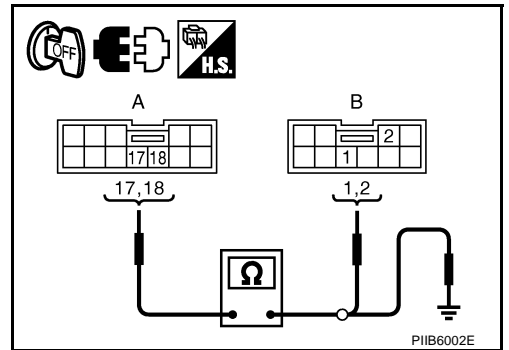

OK or NG

- OK >> GO TO 3.  
 NG >> Replace or replace harness between rear seat control unit and rear heated seat switch.

# HEATED SEAT

## 3. CHECK REAR HEATED SEAT SWITCH

Check continuity rear heated seat switch connector.

Rear heated seat switch connector	Terminal		Condition		Continuity
	1	3	Rear heated seat switch	HIGH	
B507 (LH) B558 (RH)	1	3	Rear heated seat switch	HIGH	Yes
			Other than above.		No
	2	3	Rear heated seat switch	LOW	Yes
			Other than above.		No

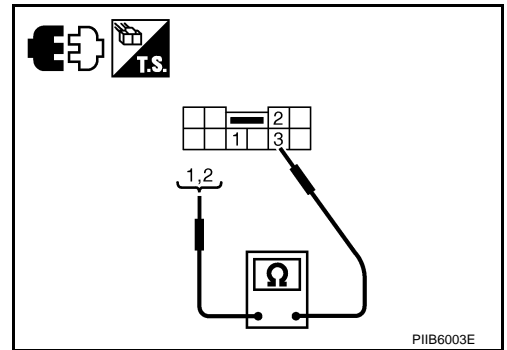

**OK or NG**

OK >> GO TO 4.

NG >> Replace rear heated seat switch.

## 4. CHECK REAR HEATED SEAT SWITCH GROUND CIRCUIT

Check continuity between rear heated seat switch connector and ground.

Terminal			Continuity
Rear heated seat switch connector	Terminal	Ground	
B507 (LH) B558 (RH)	3	Ground	Yes

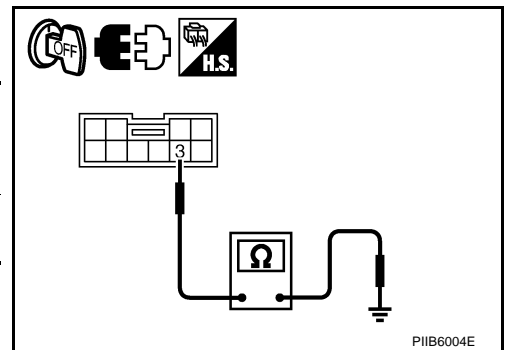

**OK or NG**

OK >> GO TO 5.

NG >> Replace or replace harness between rear heated seat switch and ground.

## 5. CHECK REAR HEATED SEAT SWITCH POWER SUPPLY-2

1. Connect rear seat control unit.
2. Turn ignition switch ON.
3. Check voltage between rear seat control unit connector and ground.

Terminals			Voltage (V) (Approx.)
(+)		(-)	
Rear seat control unit connector	Terminal	Ground	
B304 (LH) B354 (RH)	17	Ground	5
	18		

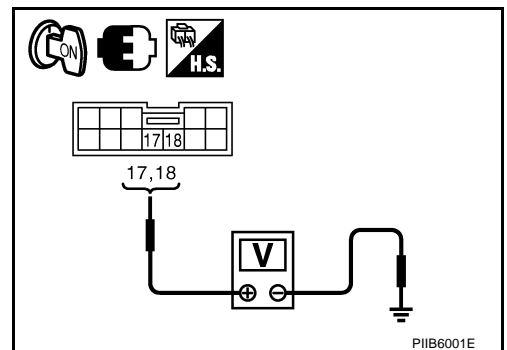

**OK or NG**

OK >> Check the condition of the harness and connector.

NG >> Replace rear seat control unit.

# HEATED SEAT

NIS0028A

## Check Rear Heated Seat Indicator Power Supply Circuit

### 1. CHECK REAR HEATED SEAT INDICATOR POWER SUPPLY

1. Turn ignition switch OFF.
2. Disconnect rear heated seat switch connector.
3. Check voltage between rear heated seat switch connector and ground.

Terminal (+)		Terminal (-)	Condition		Voltage (V) (Approx.)
Rear heated seat switch connector	Terminal				
B507 (LH) B558 (RH)	6	Ground	Ignition switch	ON	Battery voltage
				OFF	0

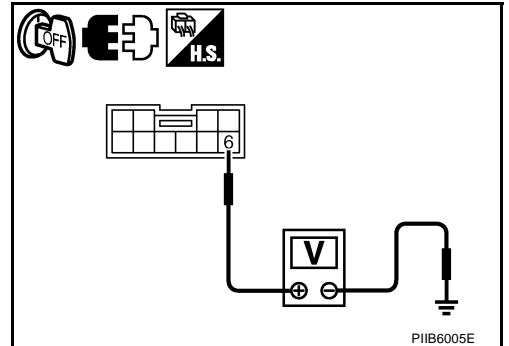

OK or NG

- OK >> GO TO 3.  
NG >> GO TO 2.

### 2. CHECK REAR HEATED SEAT INDICATOR HARNESS

1. Turn ignition switch OFF.
2. Disconnect IPDM E/R (heated seat relay) connector.
3. Check continuity between IPDM E/R (heated seat relay) connector and rear heated seat switch connector.

A		B		Continuity
Rear heated seat switch connector	Terminal	IPDM E/R (heated seat relay) connector	Terminal	
B507 (LH)	6	E6	12	Yes
B558 (RH)		E5	9	

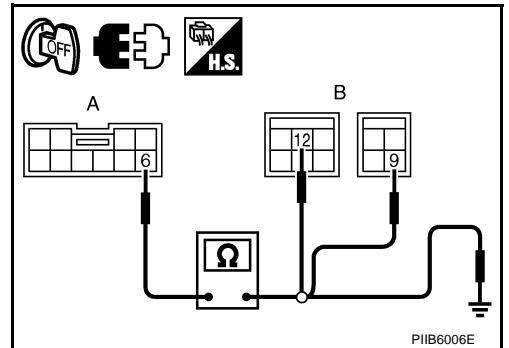

4. Check continuity between rear heated seat switch connector and ground.

A		Ground	Continuity
Rear heated seat switch connector	Terminal		
B507 (LH) B558 (RH)	6		No

OK or NG

- OK >> Check the condition of the harness and connector.  
NG >> Replace or replace harness between IPDM E/R (heated seat relay) and rear heated seat switch.

# HEATED SEAT

## 3. CHECK REAR HEATED SEAT SWITCH

Check continuity rear heated seat switch connector.

Rear heated seat switch connector	Terminal		Continuity
	(+)	(-)	
B507 (LH) B558 (RH)	4	6	Yes
	5		
	6	4	No
		5	

**OK or NG**

- OK >> Check the condition of the harness and connector.  
 NG >> Replace rear heated seat switch.

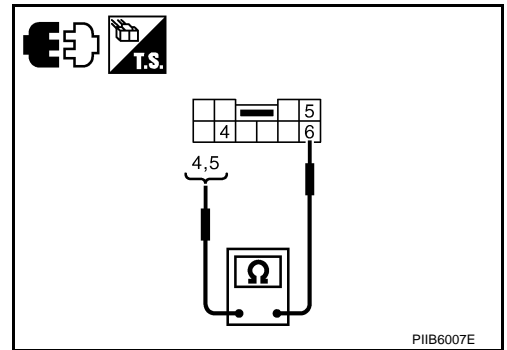

## Check Rear Heated Seat Indicator Circuit

NIS0028B

### 1. CHECK REAR SEAT CONTROL UNIT POWER SUPPLY

1. Turn ignition switch ON.
2. Check voltage between rear seat control unit connector and ground.

Terminal (+)		Terminal (-)	Condition		Voltage (V) (Approx.)
Rear seat control unit connector	Terminal				
B304 (LH) B354 (RH)	9	Ground	Rear heated seat switch	HIGH	0
			Other than above.		Battery voltage
	14		Rear heated seat switch	LOW	0
			Other than above.		Battery voltage

**OK or NG**

- OK >> Replace rear heated seat switch.  
 NG >> GO TO 2.

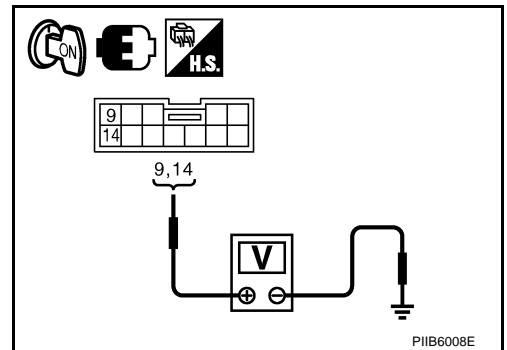

# HEATED SEAT

## 2. CHECK REAR HEATED SEAT INDICATOR HARNESS

1. Turn ignition switch OFF.
2. Disconnect rear seat control unit and rear heated seat switch connector.
3. Check continuity between rear heated seat switch connector and rear seat control unit connector.

A		B		Continuity
Rear heated seat switch connector	Terminal	Rear seat control unit connector	Terminal	
B507 (LH) B558 (RH)	4	B304 (LH)	9	Yes
	5	B354 (RH)	14	

4. Check continuity between rear heated seat switch connector and ground.

A		Ground	Continuity
Rear heated seat switch connector	Terminal		
B507 (LH) B558 (RH)	4	No	
	5		

**OK or NG**

OK >> GO TO 3.

NG >> Replace or replace harness between rear heated seat switch and rear seat control unit.

## 3. CHECK REAR HEATED SEAT SWITCH

Check continuity rear heated seat switch connector.

Rear heated seat switch connector	Terminal		Continuity
	(+)	(-)	
B507 (LH) B558 (RH)	4	6	Yes
	5		
	6	4	No
		5	

**OK or NG**

OK >> Replace rear seat control unit.

NG >> Replace rear heated seat switch.

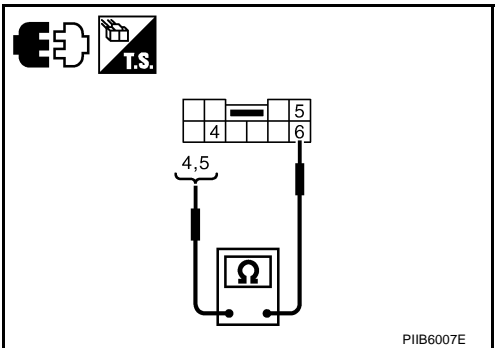
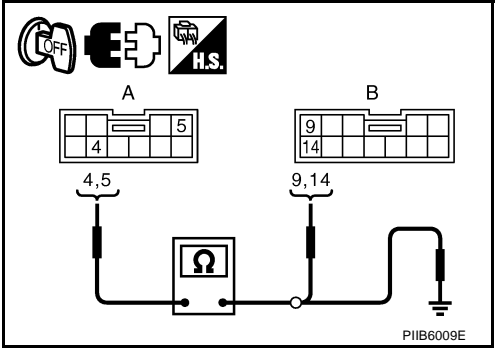



# HEATED SEAT

NIS0028C

## Check Rear Heated Seat Circuit

### 1. CHECK REAR SEAT CONTROL UNIT

1. Turn ignition switch ON.
2. Check voltage between rear seat control unit connector and ground.

Terminal (+)		Terminal (-)	Condition		Voltage (V) (Approx.)
Rear seat control unit connector	Terminal				
B303 (LH) B353 (RH)	5	Ground	Rear heated seat switch	HIGH	Battery voltage
			Other than above.		0
	6		Rear heated seat switch	LOW	Battery voltage
			Other than above.		0

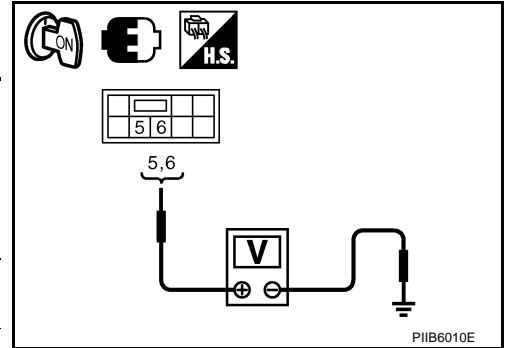

#### OK or NG

- OK >> GO TO 2.  
 NG >> Replace rear seat control unit.

### 2. CHECK REAR SEAT HEATER HARNESS

1. Turn ignition switch OFF.
2. Disconnect rear seat control unit and rear seat cushion heater connector.
3. Check continuity between rear seat control unit connector and rear seat cushion heater connector.

A		B		Continuity
Rear seat control unit connector	Terminal	Rear seat cushion heater connector	Terminal	
B303 (LH) B353 (RH)	5	B309 (LH) B359 (RH)	1	Yes
	6		2	

4. Check continuity between rear seat control unit connector and ground.

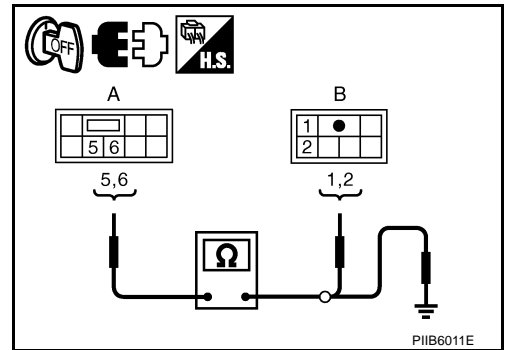

A		Ground	Continuity
Rear seat control unit connector	Terminal		
B303 (LH) B353 (RH)	5		No
	6		

#### OK or NG

- OK >> GO TO 3.  
 NG >> Replace or replace harness between rear seat control unit and rear seat cushion heater.

# HEATED SEAT

## 3. CHECK REAR SEAT HEATER CIRCUIT

1. Connect rear seat control unit and rear seat cushion heater connector.
2. Turn ignition switch ON.
3. Check voltage between rear seat cushion heater connector and ground.

Terminal		(-)	Condition		Voltage (V) (Approx.)
(+)					
Rear seat cushion heater connector	Terminal				
B309 (LH) B359 (RH)	3	Ground	Rear heated seat switch	HIGH	Battery voltage
				LOW	6
Other than above.					0

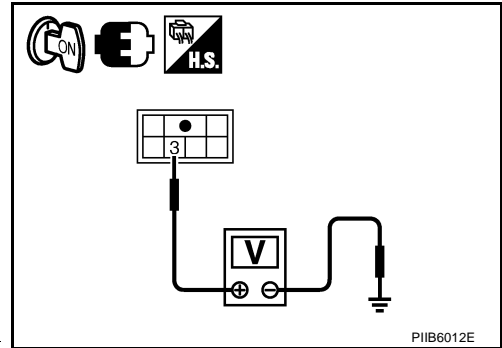

### OK or NG

- OK >> Check the condition of the harness and connector.  
 NG >> Replace rear seat cushion heater.

## Check Rear Seatback Heater Circuit

NIS0028D

### 1. CHECK REAR SEAT HEATER CIRCUIT

1. Turn ignition switch ON.
2. Check voltage between rear seat cushion heater connector and ground.

Terminal		(-)	Condition		Voltage (V) (Approx.)
(+)					
Rear seat cushion heater connector	Terminal				
B309 (LH) B359 (RH)	3	Ground	Rear heated seat switch	HIGH	Battery voltage
				LOW	6
Other than above.					0

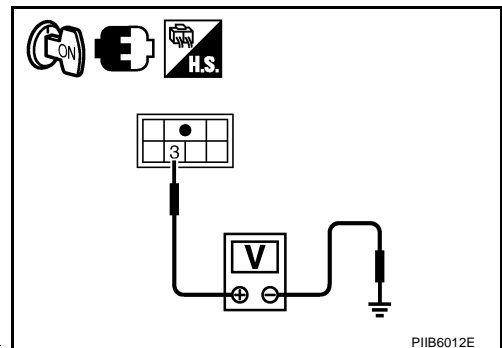

### OK or NG

- OK >> GO TO 2.  
 NG >> Replace rear seat cushion heater.

# HEATED SEAT

## 2. CHECK REAR SEAT HEATER HARNESS

1. Turn ignition switch OFF.
2. Disconnect rear seat cushion heater and rear seatback heater connector.
3. Check continuity between rear seat cushion heater connector and rear seatback heater connector.

A		B		Continuity
Rear seat cushion heater connector	Terminal	Rear seatback heater connector	Terminal	
B309 (LH) B359 (RH)	3	B310 (LH) B360 (RH)	1	Yes

4. Check continuity between rear seat cushion heater connector and ground.

A		Ground	Continuity
Rear seat cushion heater connector	Terminal		
B309 (LH) B359 (RH)	3		No

**OK or NG**

- OK >> GO TO 3.
- NG >> Replace or replace harness rear seat cushion heater and rear seatback heater.

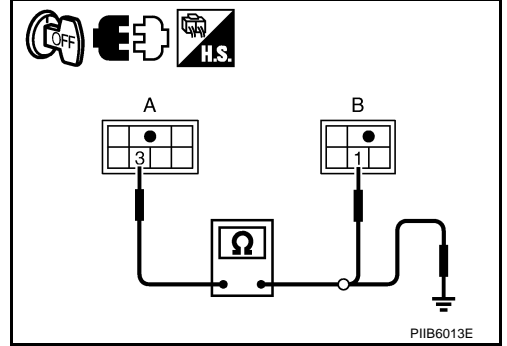

## 3. CHECK REAR SEAT HEATER GROUND CIRCUIT

Check continuity between rear seatback heater connector and ground.

Terminal		Ground	Continuity
Rear seatback heater connector	Terminal		
B310 (LH) B360 (RH)	2		Yes

**OK or NG**

- OK >> Replace rear seatback heater.
- NG >> Replace or replace harness rear seatback heater and ground.

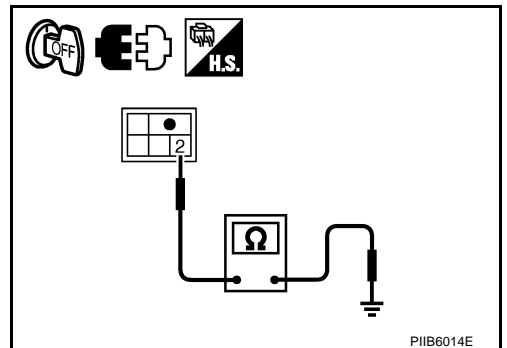

A  
B  
C  
D  
E  
F  
G  
H  
SE  
J  
K  
L  
M

# FRONT SEAT

## FRONT SEAT

PFP:87000

### Driver's Seat Components

NIS0028E

SEC. 870

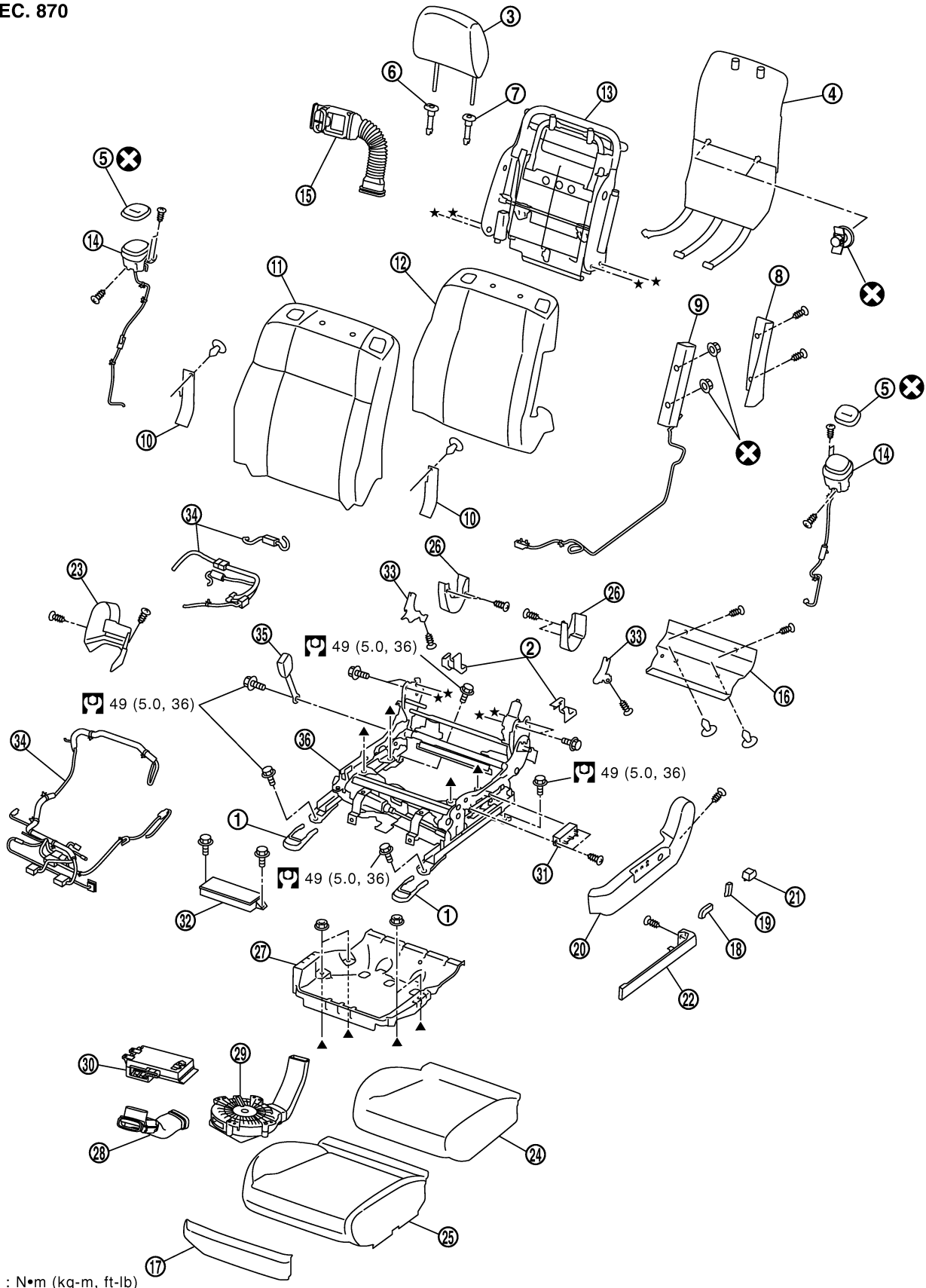

PIIB5328E

# FRONT SEAT

---

1. Front leg cover	2. Rear leg cover	3. Headrest	A
4. Seatback board	5. Seat speaker grill	6. Headrest holder (free)	
7. Headrest holder (locked)	8. Seatback upper finisher	9. Side air bag module	B
10. Reclining device cover	11. Seatback trim	12. Seatback pad	
13. Seatback frame	14. Seat speaker	15. Seatback thermal electrical device (TED) assembly	B
16. Seat cushion rear finisher (Climate controlled seat model)	17. Seat cushion front finisher	18. Seat slide switch knob	C
19. Seat reclining switch knob	20. Seat cushion outer finisher	21. Lumber support switch assembly	
22. Seat cushion lower finisher	23. Seat cushion inner finisher	24. Seat cushion pad	D
25. Seat cushion trim	26. Seat cushion finisher B	27. Seat cushion frame	
28. Seat cushion thermal electrical device (TED) assembly	29. Blower motor assembly	30. Climate controlled seat control unit	D
31. Seat control switch	32. Driver seat control unit	33. Seat cushion finisher C	E
34. Seat harness	35. Seat belt buckle	36. Seat adjuster assembly	E

F

G

H

**SE**

J

K

L

M

# FRONT SEAT

## Passenger's Seat Components

NIS0028F

SEC. 870

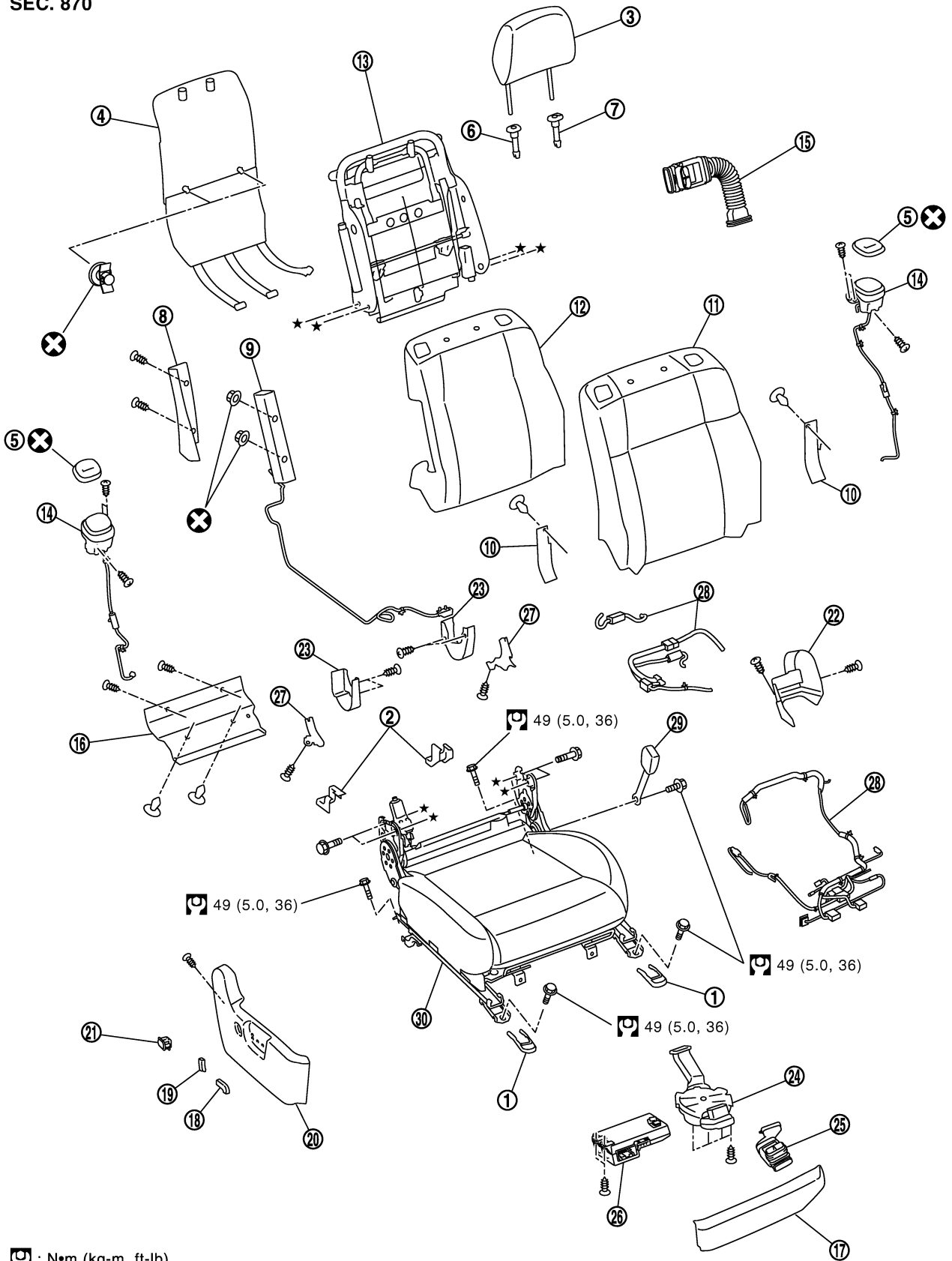

: N•m (kg-m, ft-lb)

PIIB8941E

# FRONT SEAT

---

1. Front leg cover	2. Rear leg cover	3. Headrest	A
4. Seatback board	5. Seat speaker grill	6. Headrest holder (free)	A
7. Headrest holder (locked)	8. Seatback upper finisher	9. Side air bag module	B
10. Reclining device cover	11. Seatback trim	12. Seatback pad	B
13. Seatback frame	14. Seat speaker	15. Seatback thermal electrical device (TED) assembly	C
16. Seat cushion rear finisher (Climate controlled seat model)	17. Seat cushion front finisher	18. Seat cushion slide switch	C
19. Seat reclining switch	20. Seat cushion outer finisher	21. Lumber support switch assembly	D
22. Seat inner finisher	23. Seat cushion finisher B	24. Blower motor assembly	D
25. Seat cushion thermal electrical device (TED) assembly	26. Climate controlled seat control unit	27. Seat cushion finisher C	E
28. Seat harness assembly	29. Seat belt buckle	30. Seat cushion assembly	E
			F
			G
			H
			<b>SE</b>
			J
			K
			L
			M

# FRONT SEAT

NIS0028G

## Removal and Installation

### CAUTION:

When removing and installing, use shop cloths to protect parts from damage.

### REMOVAL

1. Pull rear leg cover backward while opening outside to remove the rear leg cover.
2. Remove the mounting bolts on the back side of the front seat.

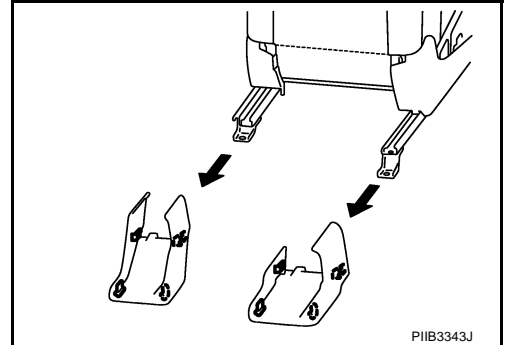

3. Pull rear leg cover forward while opening outside to remove the front leg cover.
4. Remove the mounting bolts on the front side of the front seat.

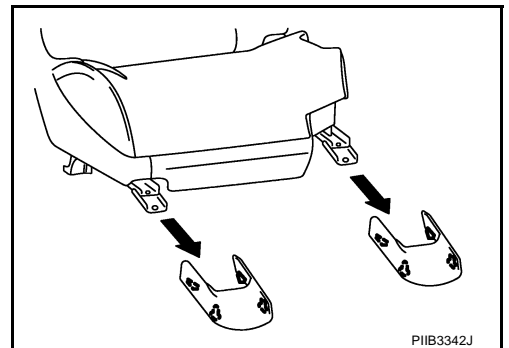

5. Disconnect harness connector under the seat and remove harness securing clips.

### CAUTION:

Before removal, be sure to turn ignition switch OFF, disconnect both battery cables, and then wait for at least 3 minutes.

6. Set seatback in a standing position.
7. Remove the headrest.
8. Remove seat from the vehicle.

### CAUTION:

When removing and installing, use shop cloths to protect parts from damage.

### INSTALLATION

Install in the reverse order of removal. Be careful of the following two points.

- Before installation, be sure to turn ignition switch OFF, disconnect both battery cables, and then wait for at least 3 minutes.
- Clamp the harness in position.

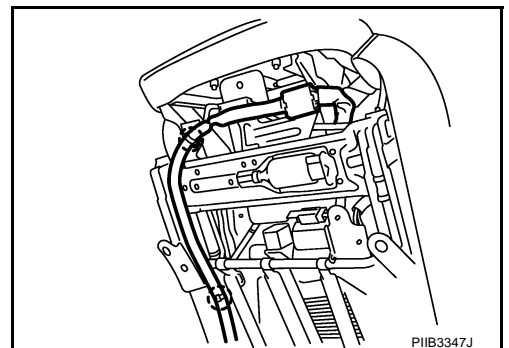



# FRONT SEAT

NIS0028H

## Disassembly and Assembly SEATBACK

### Disassembly

1. Remove seatback trim and seatback pad.

#### NOTE:

Seatback trim and seatback pad can be removed without removing seatback assembly from seat body.

- Remove the retainer from the lower side of seatback board.
- Disconnect the clips and pawls, and then remove the seatback board.

△ : Pawl

○ : Clip

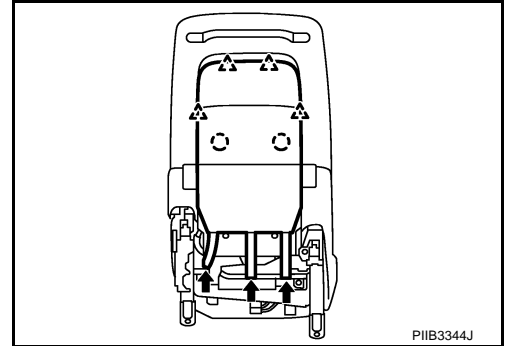

- Remove the seatback hinge mounting bolts.
- Remove the retainer on the back side of the seatback.

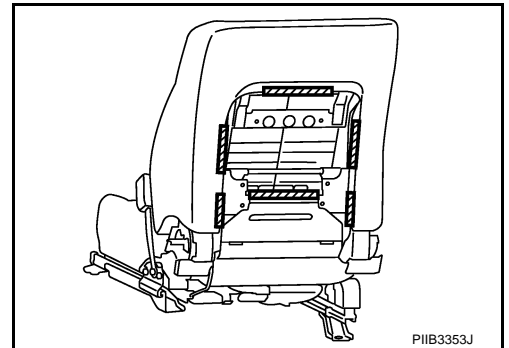

- Remove the seat speaker grills. (Applied 5.1 ch BOSE studio surround® system models.) Refer to [AV-279, "Seat Speaker"](#).
- Remove the headrest holder.

#### CAUTION:

Before installing headrest holder, check its orientation (front/rear and right/left).

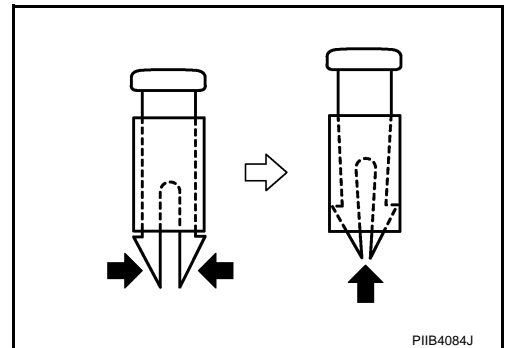

- Disconnect the clip, and then remove the reclining device cover.
- Remove the screws, and then remove the seatback upper finisher.

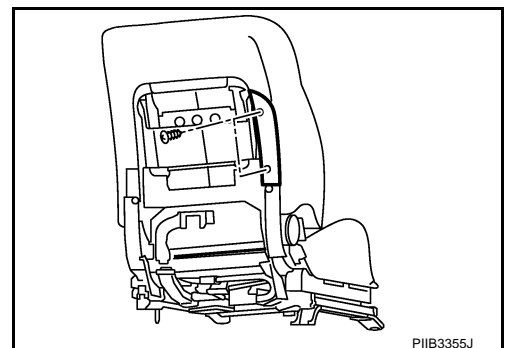

A

B

C

D

E

F

G

H

SE

J

K

L

M

# FRONT SEAT

- Remove the bracket mounting nuts.
  - Remove seatback trim and pad from seatback frame.
  - Remove the hog rings to separate the trim and pad.
2. Remove seatback frame.
- Remove seat speaker. (Applied 5.1 ch BOSE studio surround® system models) Refer to [AV-279, "Seat Speaker"](#).
  - Remove the bands, and then remove seatback thermal electrical device (TED) assembly.
  - Remove the seat harness assembly from seatback assembly.
  - Remove the bolts, and then remove seatback frame from seat cushion frame.

## Assembly

Assemble in the reverse order of disassembly. Be careful of the following one point.

Install the hog rings of seat cushion trim in position, and then securely connect the trim or trim code with the pad side wire.

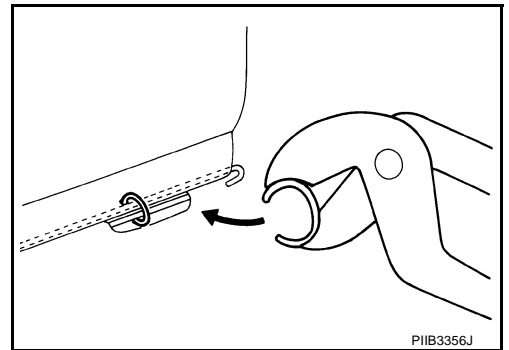

## SEAT CUSHION

### Disassembly

1. Remove the seatback trim and seatback pad.
- Remove the retainer from the lower side of seatback board.
  - Disconnect the clip and pawl, and then remove seatback board.

△ : Pawl  
○ : Clip

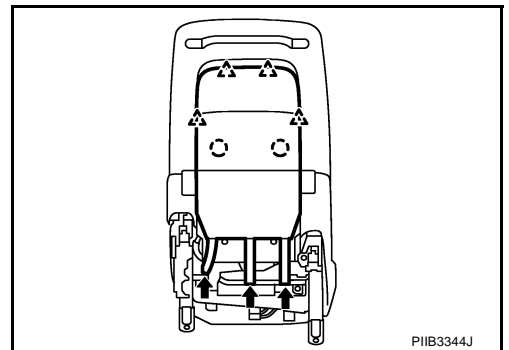

- Remove the screws and disconnect the clips, and then remove the seat cushion rear finisher. (Climate controlled seat model)

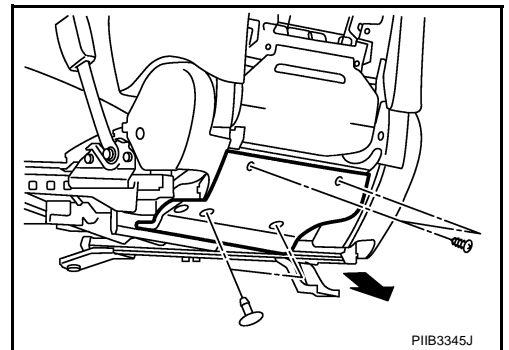

# FRONT SEAT

- Remove the seat cushion front finisher.

△ : Pawl  
○ : Clip

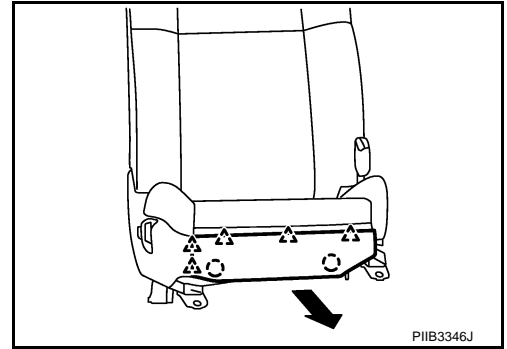

- Remove the seat reclining switch knob and seat slide switch knob.

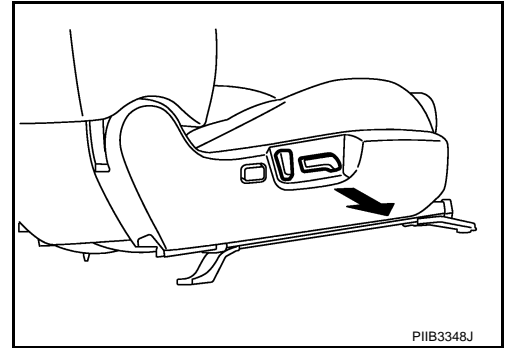

- Pull seat cushion outer finisher forward, and then disconnect the pawls and clips.

△ : Pawl  
○ : Clip

- Lift the rear part of the seat cushion outer finisher backward, and then remove the seat cushion outer finisher.

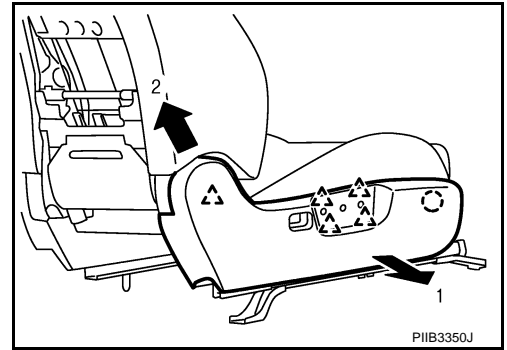

- Remove the harness connector clamp of lumbar support switch.
- Removal the lumbar support switch.
- Remove the seat cushion inner finisher.

△ : Pawl

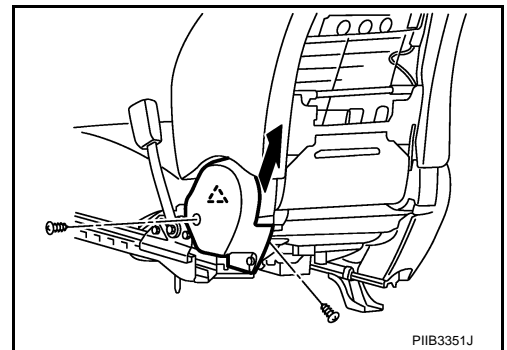

- Remove the retainers from the lower side of front seat. (Driver's seat only)
  - Remove the hog rings to separate the trim and pad. (Driver's seat only)
2. Remove the nuts, and then remove the seat cushion frame. (Driver's seat only)
  3. Remove each unit which is attached to seat cushion frame and seat adjuster assembly.
    - Remove the screws, and then remove the climate controlled seat control unit.
    - Remove the screws, and then remove the blower motor.
    - Remove the bands, and then remove the seat cushion thermal electrical device (TED) assembly.

A  
B  
C  
D  
E  
F  
G  
H  
SE  
J  
K  
L  
M

## FRONT SEAT

- Remove driver's seat control unit. (Driver's seat only)
- Remove the driver seat control switch.

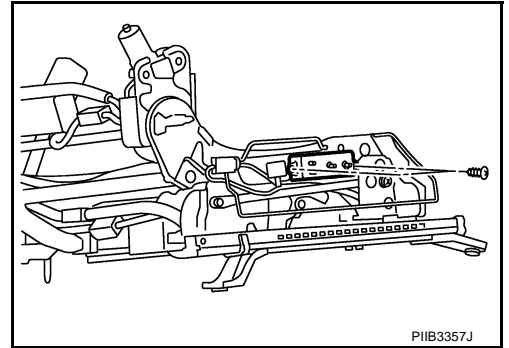

- Remove seat cushion finisher B and seat cushion finisher C.
- Remove seat harnesses.

### Assembly

Assemble in the reverse order of disassembly. Be careful of the following two points.

- Install the hog rings of seat cushion trim in position, and then securely connect the trim or trim code with the pad side wire.

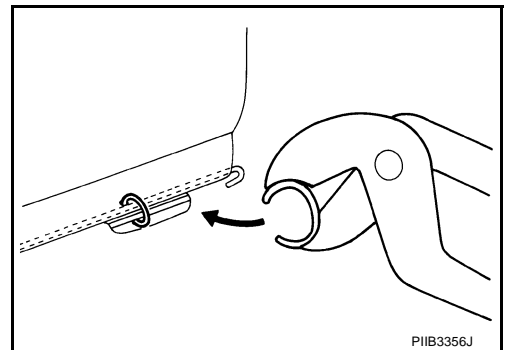

- Clamp the harness in position.

### CLIMATE CONTROLLED SEAT

#### Blower Filter Replacement

Put your hand behind front seat cushion, pull filter downward and remove it. Replace filter with a new one.

#### NOTE:

- When replacing, be sure to set the front seat lifter to the top position.
- When installing, do not confuse up-down direction of the filter.

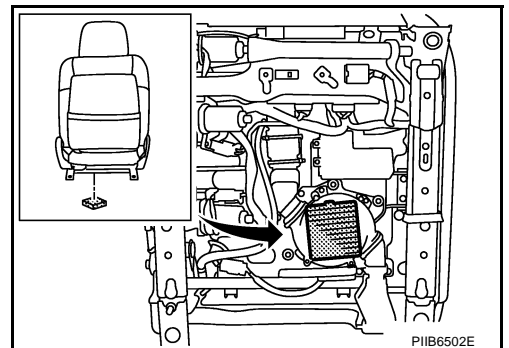

# REAR SEAT

## REAR SEAT

PFP:88300

### Bench Seat Components

NIS0028I

SEC. 880

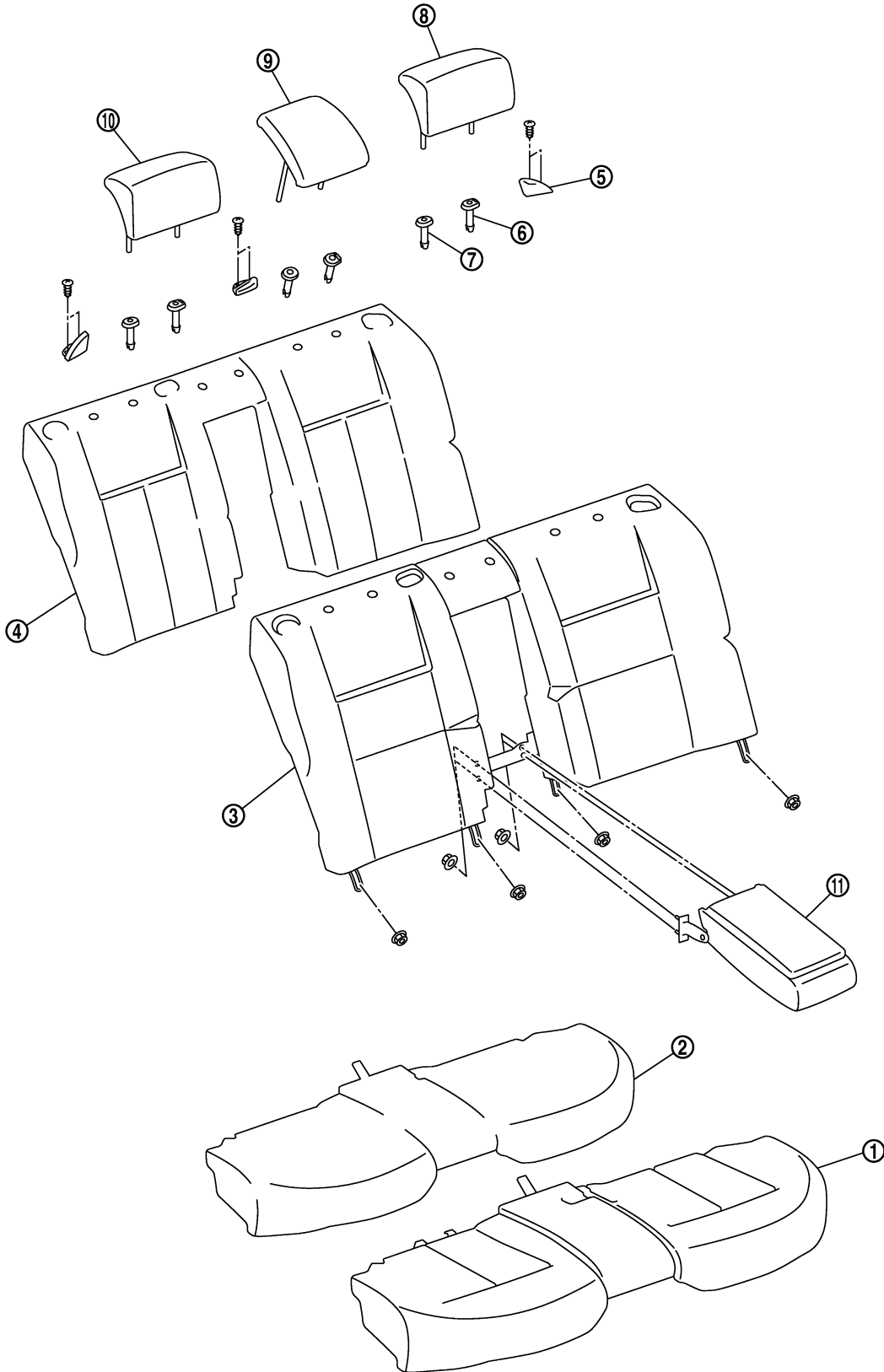

A  
B  
C  
D  
E  
F  
G  
H  
SE  
J  
K  
L  
M

## REAR SEAT

---

- |                           |                     |                             |
|---------------------------|---------------------|-----------------------------|
| 1. Seat cushion trim      | 2. Seat cushion pad | 3. Seatback pad             |
| 4. Seatback trim          | 5. Seat belt guide  | 6. Headrest holder (locked) |
| 7. Headrest holder (free) | 8. Headrest (left)  | 9. Headrest (center)        |
| 10. Headrest (right)      | 11. Armrest         |                             |

# REAR SEAT

## Power Seat (Split Type) Components

NIS0026J

SEC. 880

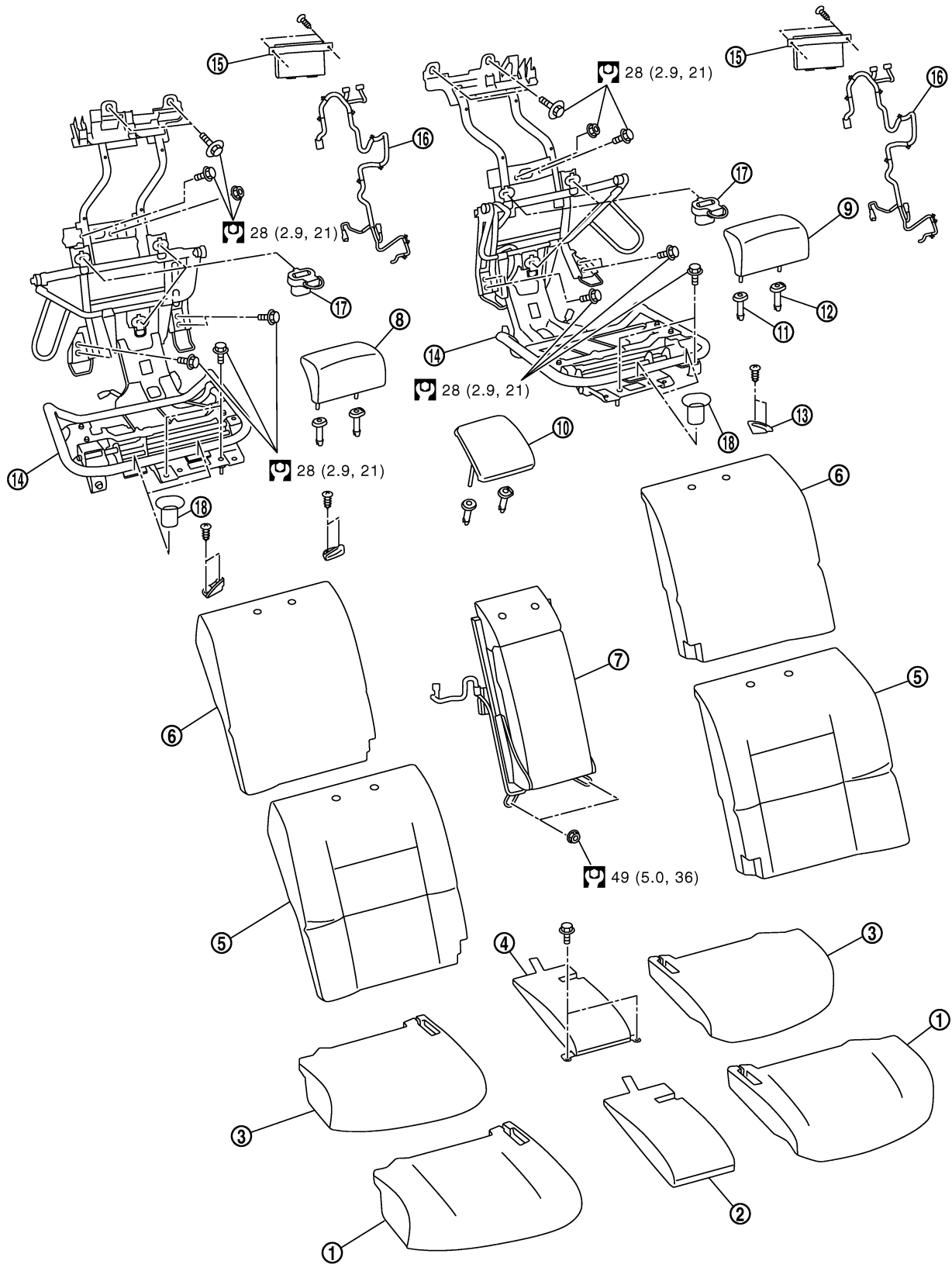

: N•m (kg-m, ft-lb)

A  
B  
C  
D  
E  
F  
G  
H  
SE  
J  
K  
L  
M

## REAR SEAT

---

- |                            |                             |                              |
|----------------------------|-----------------------------|------------------------------|
| 1. Seat cushion side trim  | 2. Seat cushion center trim | 3. Seat cushion side pad     |
| 4. Seat cushion center pad | 5. Seatback trim            | 6. Seatback pad              |
| 7. Seatback center         | 8. Headrest (right)         | 9. Headrest (left)           |
| 10. Headrest (center)      | 11. Headrest holder (free)  | 12. Headrest holder (locked) |
| 13. Seat belt guide        | 14. Rear seat frame         | 15. Rear seat control unit   |
| 16. Rear seat harness      | 17. Seatback hook           | 18. Seat cushion hook        |



# REAR SEAT

NIS0028K

## Removal and Installation

### CAUTION:

When removing and installing, use shop cloths to protect parts from damage.

### BENCH SEAT

#### Removal

1. Remove seat cushion.
  - Pull the lock lever at the front bottom of the seat cushion forward (1 for each side), and pull the seat cushion upward to release the wire from the seat cushion hook, then pull the seat cushion forward to remove.
  - Remove the seat cushion from the vehicle.
2. Remove seat back.
  - Remove the nuts under seatback.
  - Lift up seatback assembly from underneath, and then remove seatback assembly from seatback hook that is fixed to the vehicle.
  - Remove the headrest.
  - Remove the seatback from the vehicle.

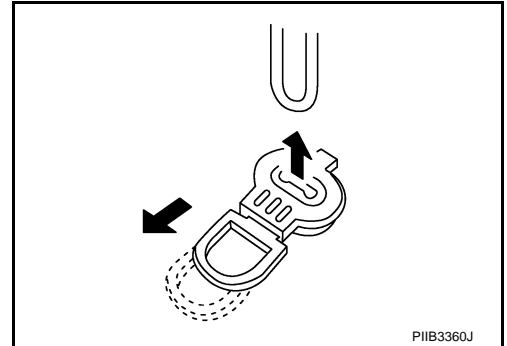

#### Installation

Install in the reverse order of removal. Be careful of the following one point. Securely engage the upper wire on the back side of seatback with seat hook.

### POWER SEAT

#### Removal

1. Remove seat cushion side.
  - Lift seat cushion side up, disengage the seat cushion hook, and then remove the seat cushion side.
  - Remove the seat cushion side from the vehicle.

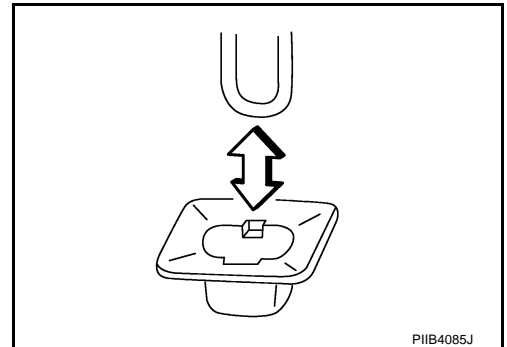

2. Remove the seat cushion center.
  - Disconnect the harness connector.
  - Remove the bolts, and then remove the seat cushion center from the vehicle.

3. Remove seatback side.
  - Access to the back side of seatback side from the lower, and then pull the lock lever of seatback hook downward.
  - Pull seatback side, and then remove seatback side from the seatback hook.  
○: Seatback hook

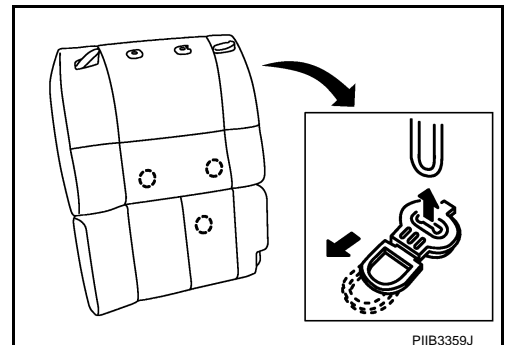

- Lift up seatback side from underneath, and then remove seatback side from seatback hook.
- Disconnect the harness connector.

# REAR SEAT

- Remove the headrest.
  - Remove the seatback side from the vehicle.
4. Remove seatback center.
    - Disconnect the harness connector.
    - Remove the seatback center mounting bolts and nuts.
    - Remove the seatback center from the vehicle.
  5. Remove the rear seat frame.
    - Disconnect the harness connector.
    - Remove the bolts and nuts, and then remove the rear seat frame.

## Installation

Install in the reverse order of removal.

## Disassembly and Assembly BENCH SEAT

NIS0028L

### Disassembly of Seat Cushion

Remove the hog rings to separate the trim and pad.

### Assembly of Seat Cushion

Assemble in the reverse order of disassembly. Be careful of the following one point.  
Install hog rings of seat cushion trim in position, and then securely connect the trim or trim code with the pad side wire.

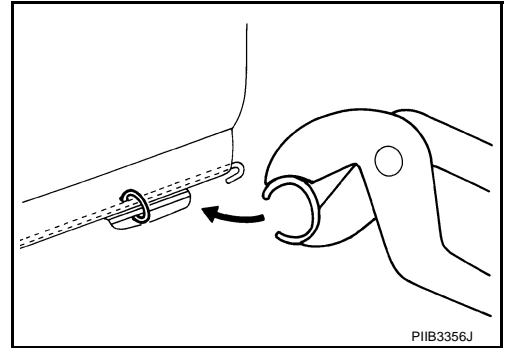

### Disassembly of Seatback

1. Remove the headrest holder.

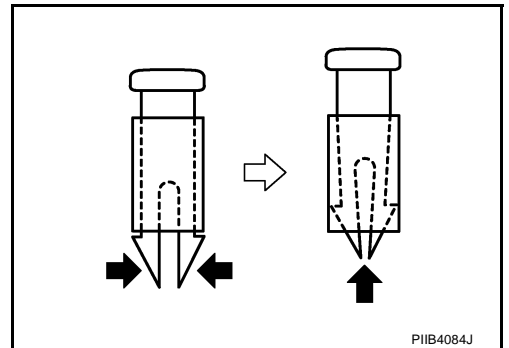

2. Remove the seat belt guide.
3. Remove the hog rings to separate the trim and pad.

### Assembly of Seatback

Assemble in the reverse order of disassembly. Be careful of the following one point.

## REAR SEAT

Install hog rings of seat cushion trim in position, and then securely connect the trim or trim code with the pad side wire.

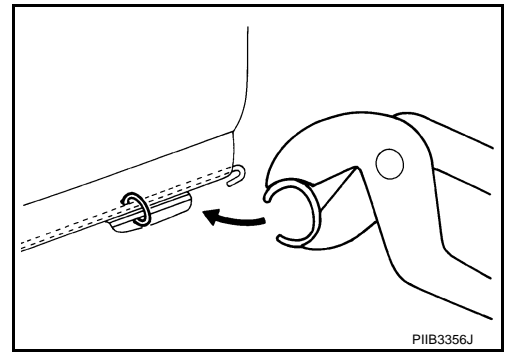

### Disassembly of Armrest

1. Remove the armrest from seatback.
  - Remove the retainer from the side of armrest lid in the back.
  - Remove the armrest mounting nuts on the back of seatback.
2. Disassemble the armrest.

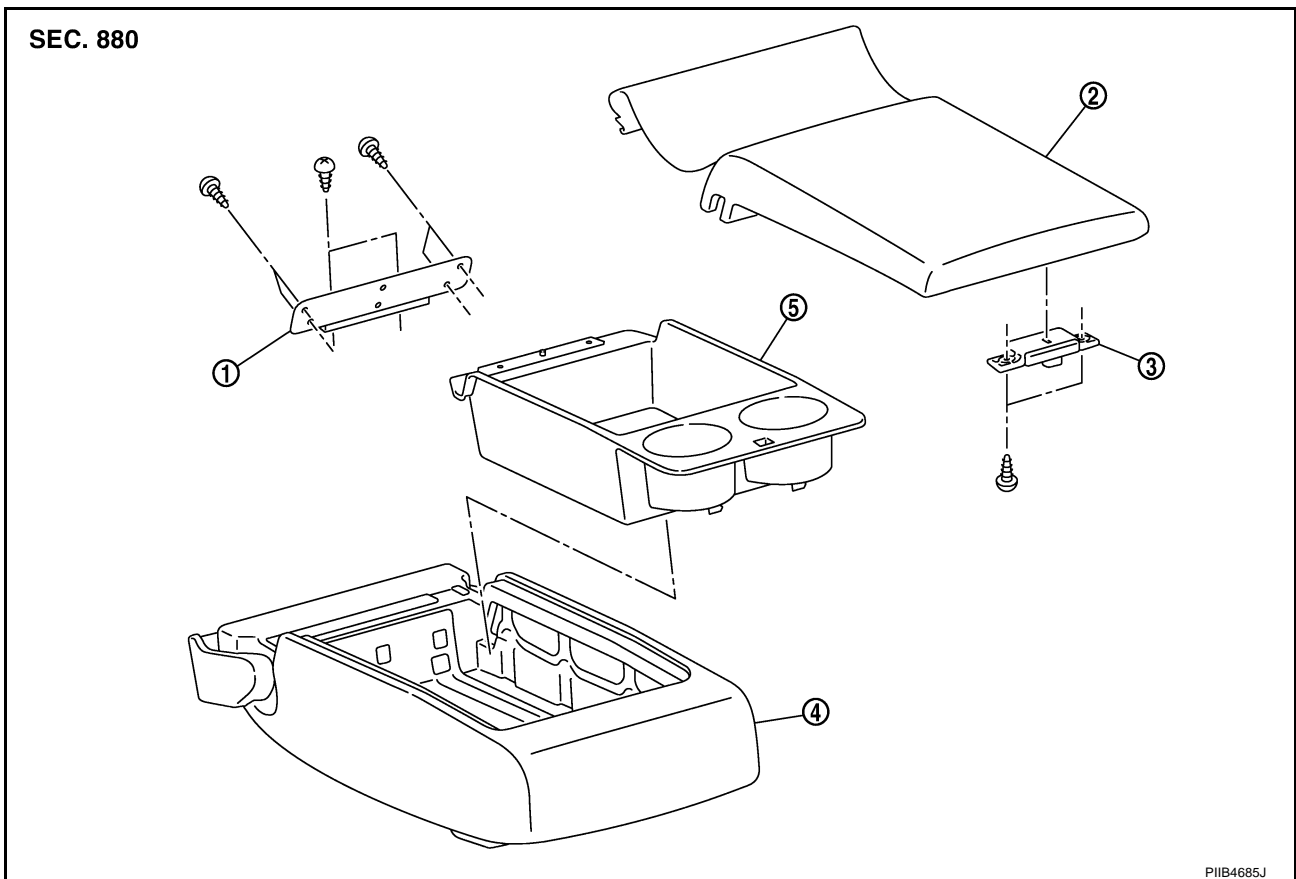

- |                      |                  |                          |
|----------------------|------------------|--------------------------|
| 1. Armrest lid hinge | 2. Armrest lid   | 3. Armrest lock assembly |
| 4. Armrest assembly  | 5. Rear seat box |                          |

- Remove the screws, and then remove armrest lid hinge.
- Remove the armrest lid.
- Remove screws, and then remove the armrest lock assembly from the armrest lid.

A  
B  
C  
D  
E  
F  
G  
H  
SE  
J  
K  
L  
M

## REAR SEAT

- Pull the rear seat box rearward and lift up, and then remove rear seat box from the armrest assembly.

### CAUTION:

- When removing, check that front tab is not damaged.
- If the tab is damaged when removing the rear seat box, replace rear seat box with a new one.

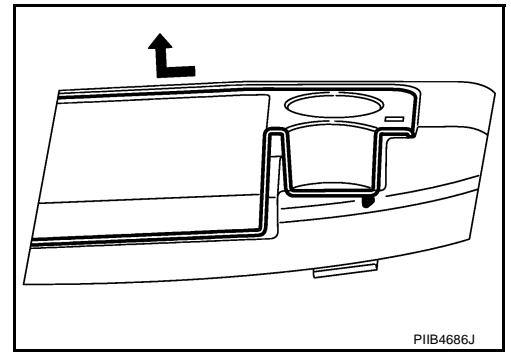

### Assembly of Armrest

Assemble in the reverse order of disassembly.

## POWER SEAT

### Disassembly of Seat Cushion

Remove the hog rings to separate the trim and pad.

### Assembly of Seat Cushion

Assemble in the reverse order of disassembly.

### Disassembly of Seatback

1. Remove the headrest holder.
2. Remove the seat belt guide.
3. Remove the hog rings to separate the trim and pad.

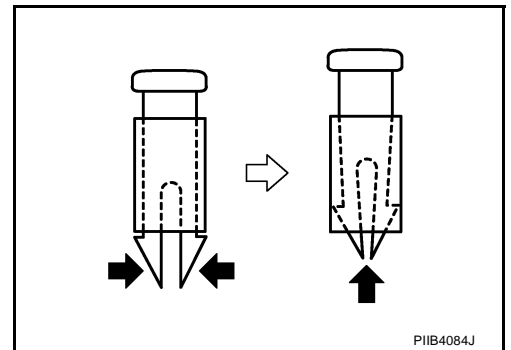

### Assembly of Seatback

Assemble in the reverse order of disassembly. Be careful of the following one point.  
Install hog rings of seat cushion trim in position, and then securely connect the trim or trim code with the pad side wire.

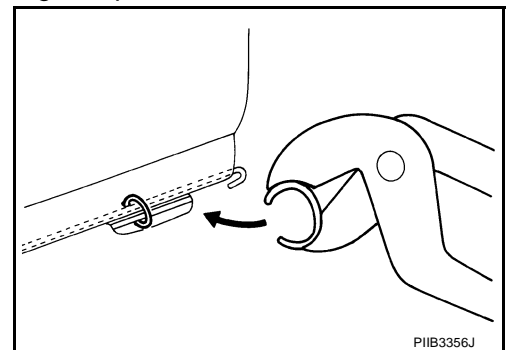

### Disassembly of Seat Frame

1. Disconnect the harness connectors, remove the screws, and then remove the rear seat control unit.
2. Remove the seatback hook and seat cushion hook.

### Assembly of Seat Frame

Assemble in the reverse order of removal.

### Disassembly of Armrest

1. Remove the armrest from seatback center.
  - Remove the retainer from the side of armrest lid in the back.
  - Remove the armrest mounting nuts on the back of seatback.

# REAR SEAT

## 2. Disassemble the armrest.

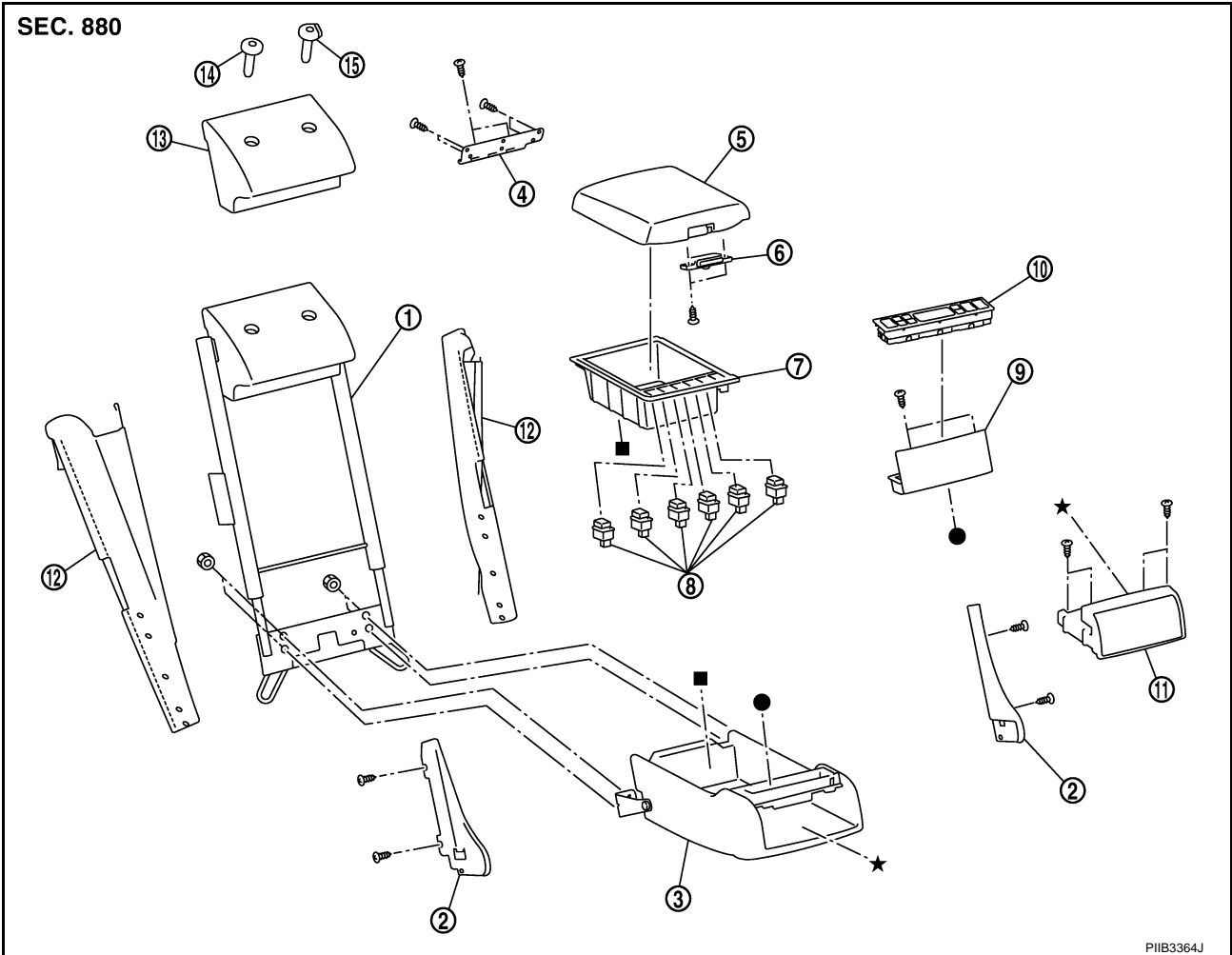

- |                          |                            |                               |
|--------------------------|----------------------------|-------------------------------|
| 1. Seatback center       | 2. Armrest hinge cover     | 3. Armrest assembly           |
| 4. Armrest lid hinge     | 5. Armrest lid             | 6. Armrest lid lock assembly  |
| 7. Rear seat box         | 8. Switch                  | 9. A/C box assembly           |
| 10. Rear seat control    | 11. Cup holder             | 12. Seatback center side trim |
| 13. Seatback center trim | 14. Headrest holder (free) | 15. Headrest holder (locked)  |

- Remove the screws, and then remove the armrest hinge cover.
- Remove the screws, and then remove the armrest lid hinge.
- Remove the armrest lid.
- Remove the screws, and then remove the armrest lid lock assembly from the armrest lid.
- Remove the rear seat box.
- Remove all switches from the rear seat box.
- Remove the screws, and then remove the A/C box assembly.
- Remove the screws, and then remove the cup holder.
- Remove the hog rings, and then remove the seat back center side trim.
- Remove the headrest holder, and then remove the seatback center trim.

### Assembly of Armrest

Assemble in the reverse order of removal.

A  
B  
C  
D  
E  
F  
G  
H  
SE  
J  
K  
L  
M

# REAR SEAT

---