

# MANUAL TRANSMISSION

## SECTION **MT**

### CONTENTS

<b>PREPARATION</b> .....	1	Case Components .....	9
Special Service Tools .....	1	Gear Components .....	10
Commercial Service Tools .....	2	Shift Control Components .....	12
<b>NOISE, VIBRATION AND HARSHNESS (NVH)</b>		<b>DISASSEMBLY</b> .....	13
<b>TROUBLESHOOTING</b> .....	3	Case Components .....	13
NVH Troubleshooting Chart.....	3	Shift Control Components .....	14
<b>ON-VEHICLE SERVICE</b> .....	4	Gear Components .....	15
Replacing Rear Oil Seal.....	4	<b>INSPECTION</b> .....	19
Position Switch Check .....	4	Shift Control Components .....	19
<b>REMOVAL AND INSTALLATION</b> .....	5	Gear Components .....	19
Removal.....	5	<b>ASSEMBLY</b> .....	21
Installation.....	6	Gear Components .....	21
<b>DESCRIPTION</b> .....	7	Shift Control Components .....	29
Cross-sectional View .....	7	Case Components .....	29
<b>AIR BREATHER</b> .....	8	<b>SERVICE DATA AND SPECIFICATIONS (SDS)</b> .....	32
Air Breather Piping .....	8	General Specifications.....	32
<b>MAJOR OVERHAUL</b> .....	9	Inspection and Adjustment .....	33

# PREPARATION

## Special Service Tools

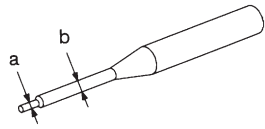
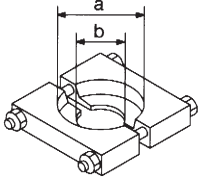
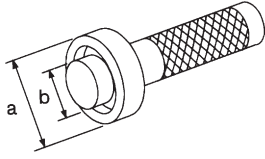
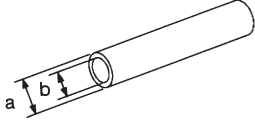
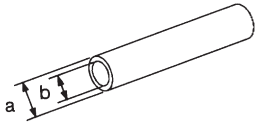
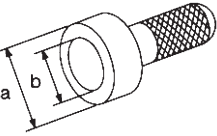
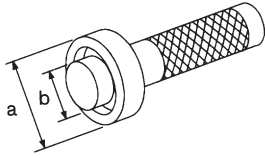
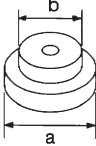
Tool number Tool name	Description	
ST23540000 Pin punch	NT442	 <p>Removing and installing retaining pin</p> <p><b>a: 2.3 mm (0.091 in) dia.</b> <b>b: 4 mm (0.16 in) dia.</b></p>
ST30031000 Puller	NT411	 <p>Removing 1st &amp; 2nd synchronizer assembly Removing counter gear rear thrust bearing Removing main drive gear bearing</p> <p><b>a: 90 mm (3.54 in) dia.</b> <b>b: 50 mm (1.97 in) dia.</b></p>
ST33230000 Drift	NT084	 <p>Removing mainshaft and counter gear</p> <p><b>a: 51 mm (2.01 in) dia.</b> <b>b: 28.5 mm (1.122 in) dia.</b></p>
ST22350000 Drift	NT065	 <p>Removing and installing mainshaft rear bearing Removing counter gear front bearing (Use with KV38100300)</p> <p><b>a: 34 mm (1.34 in) dia.</b> <b>b: 28 mm (1.10 in) dia.</b></p>
KV38100300 Drift	NT065	 <p>Removing counter gear front bearing (Use with ST22350000) Installing counter gear rear bearing</p> <p><b>a: 54 mm (2.13 in) dia.</b> <b>b: 32 mm (1.26 in) dia.</b></p>
ST30720000 Drift	NT115	 <p>Removing mainshaft front bearing Installing mainshaft front bearing</p> <p><b>a: 77 mm (3.03 in) dia.</b> <b>b: 55.5 mm (2.185 in) dia.</b></p>
ST33210000 Drift	NT084	 <p>Installing counter gear front bearing Installing front cover oil seal</p> <p><b>a: 44 mm (1.73 in) dia.</b> <b>b: 24.5 mm (0.965 in) dia.</b></p>
ST30613000 Drift	NT073	 <p>Installing main drive gear bearing</p> <p><b>a: 71.5 mm (2.815 in) dia.</b> <b>b: 47.5 mm (1.870 in) dia.</b></p>

## PREPARATION

### Special Service Tools (Cont'd)

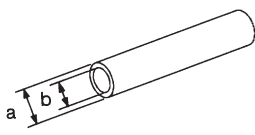
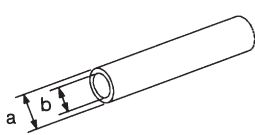
Tool number Tool name	Description
ST37750000 Drift	<div style="display: flex; align-items: center; justify-content: center;">  </div> <p style="text-align: center;">NT065</p>
	<p>Removing and installing mainshaft rear bearing            Removing counter gear rear bearing            Installing OD gear bushing            Installing reverse cone            Installing reverse counter gear            Installing counter gear rear end bearing</p> <p><b>a: 40 mm (1.57 in) dia.</b>  <b>b: 31 mm (1.22 in) dia.</b></p>
ST22452000 Drift	<div style="display: flex; align-items: center; justify-content: center;">  </div> <p style="text-align: center;">NT065</p>
	<p>Installing reverse hub</p> <p><b>a: 45 mm (1.77 in) dia.</b>  <b>b: 36 mm (1.42 in) dia.</b></p>

### Commercial Service Tools

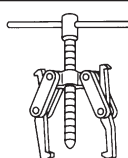
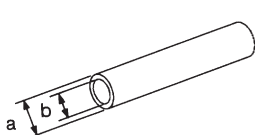
Tool name	Description
Puller	<div style="display: flex; align-items: center; justify-content: center;">  </div> <p style="text-align: center;">NT077</p>
	<p>Removing counter gear rear end bearing            Removing reverse synchronizer hub            Removing reverse counter gear</p>
Drift	<div style="display: flex; align-items: center; justify-content: center;">  </div> <p style="text-align: center;">NT065</p>
	<p>① Installing sub-gear snap ring            ② Installing OD main gear</p> <p>① <b>a: 44.5 mm (1.752 in) dia.</b>  <b>b: 38.5 mm (1.516 in) dia.</b>            ② <b>a: 44.5 mm (1.752 in) dia.</b>  <b>b: 40.5 mm (1.594 in) dia.</b></p>



## ON-VEHICLE SERVICE

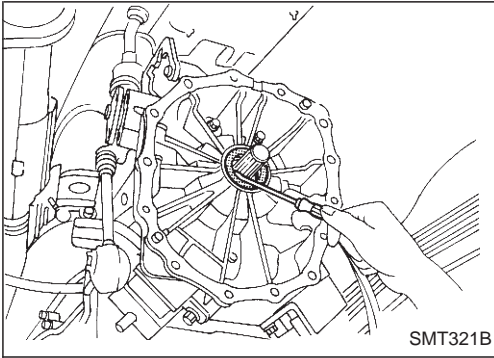

### Replacing Rear Oil Seal

#### REMOVAL

1. Remove transfer assembly. — Refer to TF section.
2. Pull out rear oil seal.

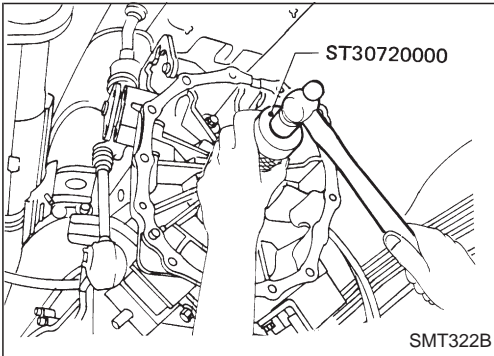

#### INSTALLATION

1. Install rear oil seal.
  - **Before installing apply multi-purpose grease to seal lip.**
2. Install transfer assembly. — Refer to TF section.

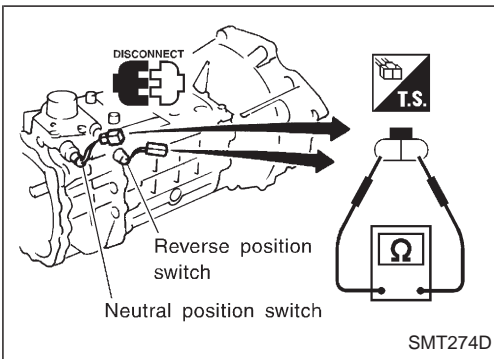

### Position Switch Check

Switch	Gear position	Continuity
Reverse position switch	Reverse	Yes
	Except reverse	No
Neutral position switch	Neutral	Yes
	Except neutral	No

# REMOVAL AND INSTALLATION

## Removal

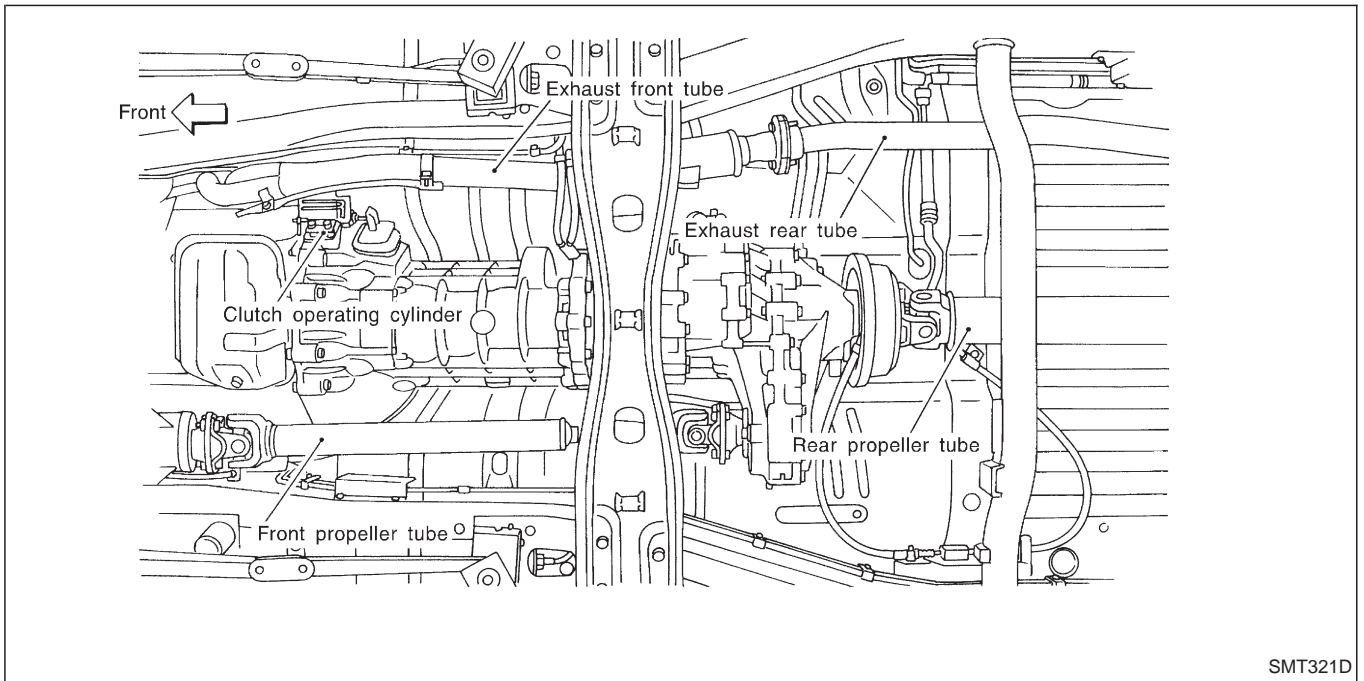

SMT321D

1. Remove front and rear propeller shafts. Refer to PD section ("Removal and Installation", "PROPELLER SHAFT").
2. Remove clutch operating cylinder.
3. Remove exhaust front and rear tubes. Refer to FE section ("EXHAUST SYSTEM").
4. Disconnect vehicle speed sensor, back-up lamp switch, 4WD switch and neutral position switch harness connector.
5. Remove center brake cable. Refer to BR section.
6. Remove shift lever of transmission. Refer to MT-12 (RS5R30A).
7. Remove transfer control lever. Refer to TF section ("Removal", "REMOVAL AND INSTALLATION").
8. Support engine by placing a jack under oil pan.
  - **Do not place jack under the oil pan drain plug.**
9. Remove transmission with transfer from engine.

### **WARNING:**

**Support Manual Transmission with transfer, while removing it.**

# REMOVAL AND INSTALLATION

## Installation

- Apply sealant as below:

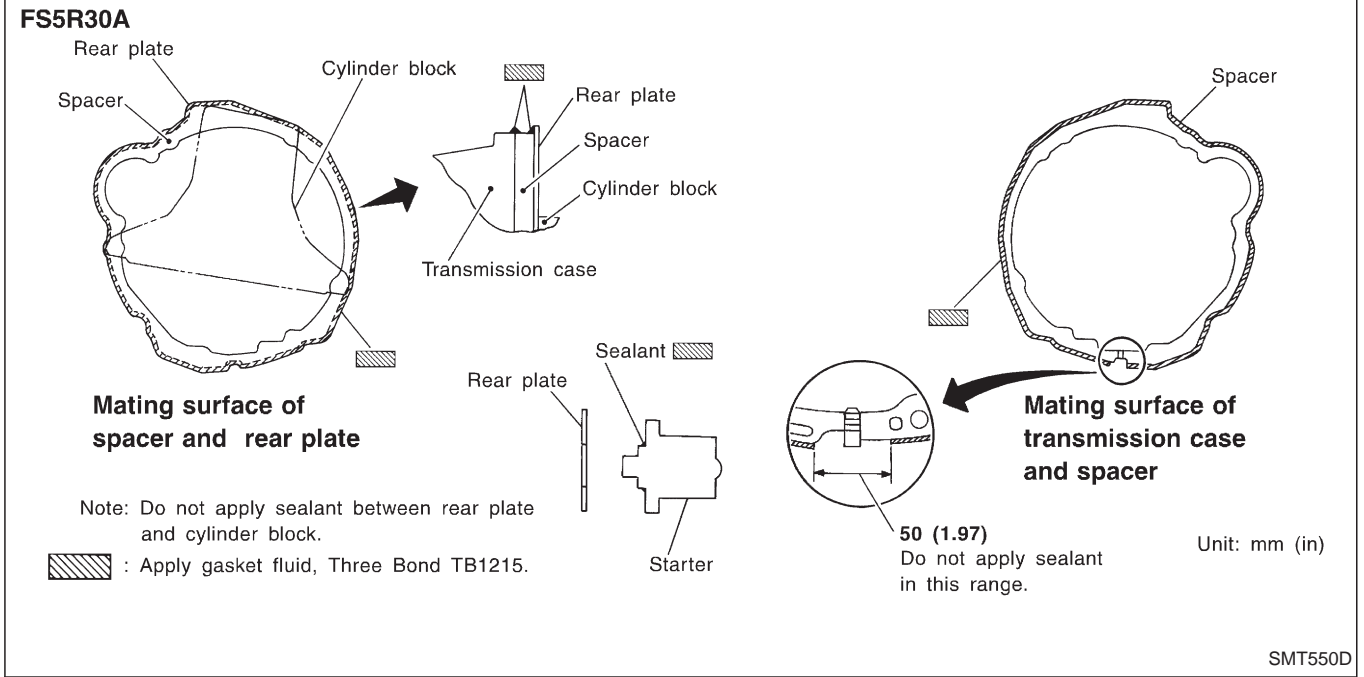

## RD28ETi engine

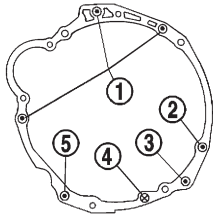

- ⊙ M/T to engine
- ⊗ Engine to M/T

SMT322D

- Tighten bolts securing transmission.

Bolt No.	Tightening torque N·m (kg·m, ft·lb)	ℓ mm (in)
①	39 - 49 (4.0 - 5.0, 29 - 36)	79 (3.11)
②	39 - 49 (4.0 - 5.0, 29 - 36)	85 (3.35)
③	29 - 39 (3.0 - 4.0, 22 - 29)	79 (3.11)
④	29 - 39 (3.0 - 4.0, 22 - 29)	57 (2.24)
⑤	29 - 39 (3.0 - 4.0, 22 - 29)	50 (1.97)
Gusset to engine	29 - 39 (3.0 - 4.0, 22 - 29)	35 (1.38)







# AIR BREATHER

## Air Breather Piping

Remarks:

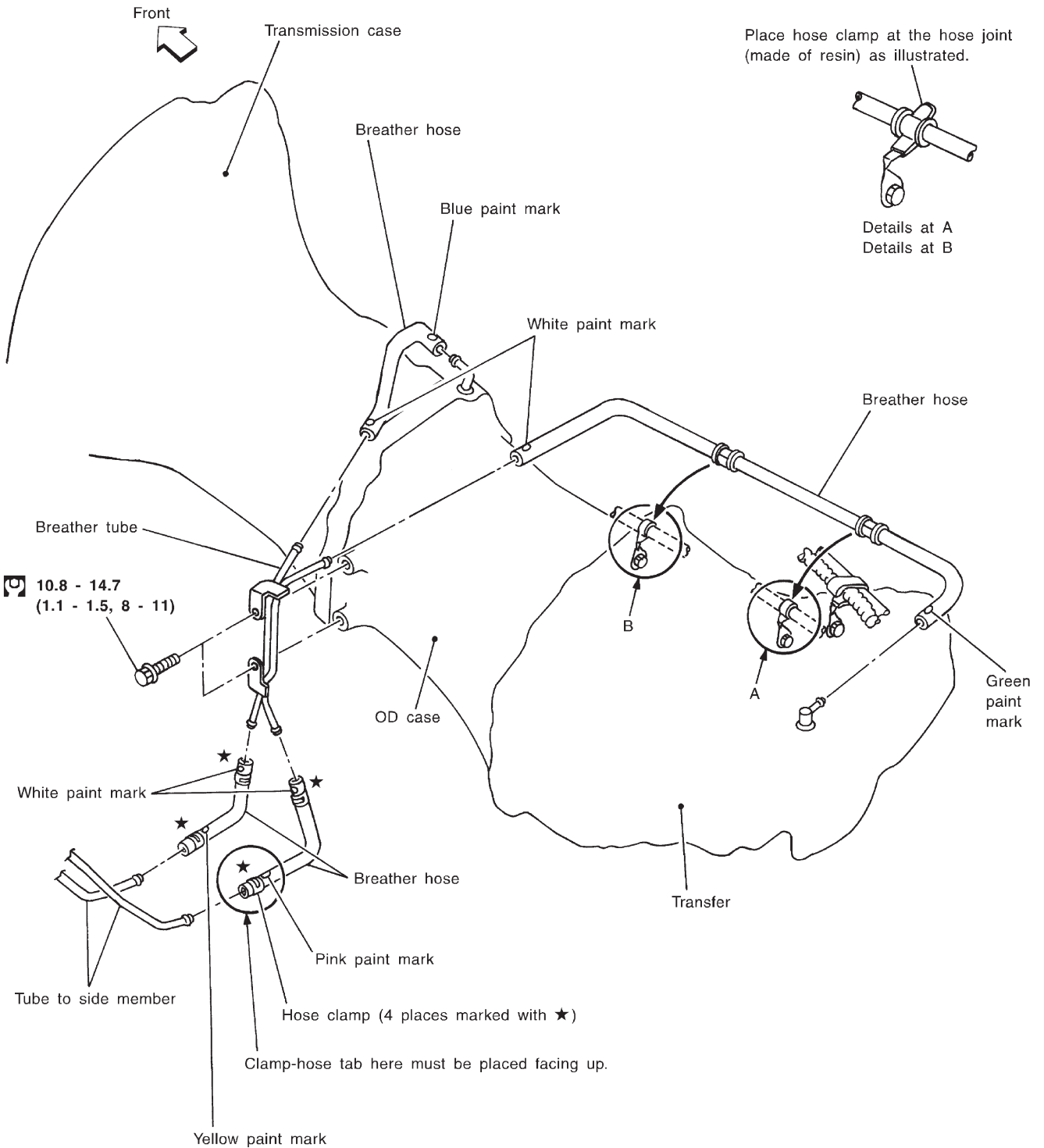
1. Route rubber hoses so that they are not bent or pinched.
2. Hose insertion
  - Insert the tube bulge spool into the spool.
  - Insert the tube bulge into the right-angle bend section of the tube.
  - Insert unit bulge until the hose cannot go in any further.



 : N•m (kg-m, ft-lb)



# MAJOR OVERHAUL

## Gear Components

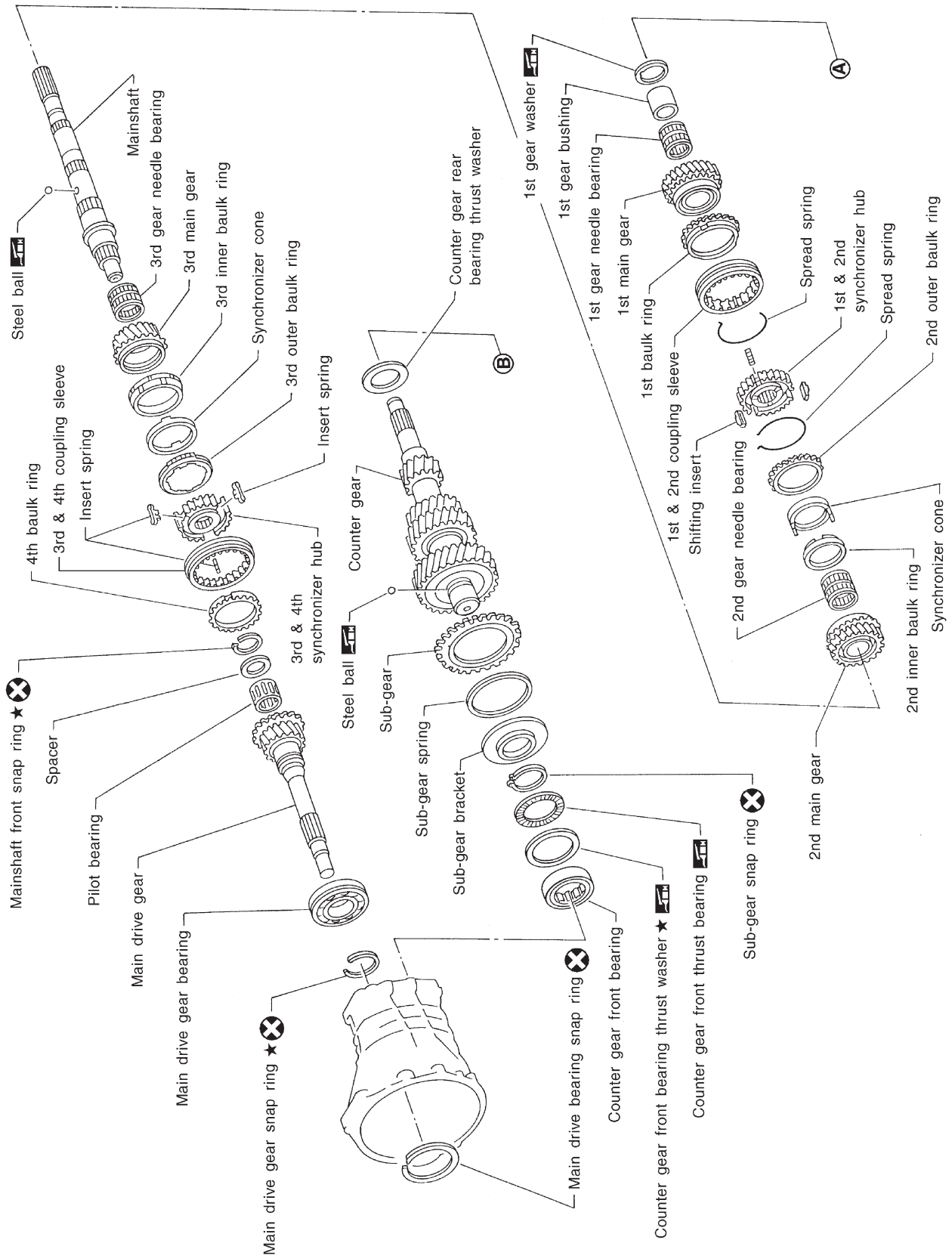

SEC. 322

# MAJOR OVERHAUL

## Gear Components (Cont'd)

SEC. 322

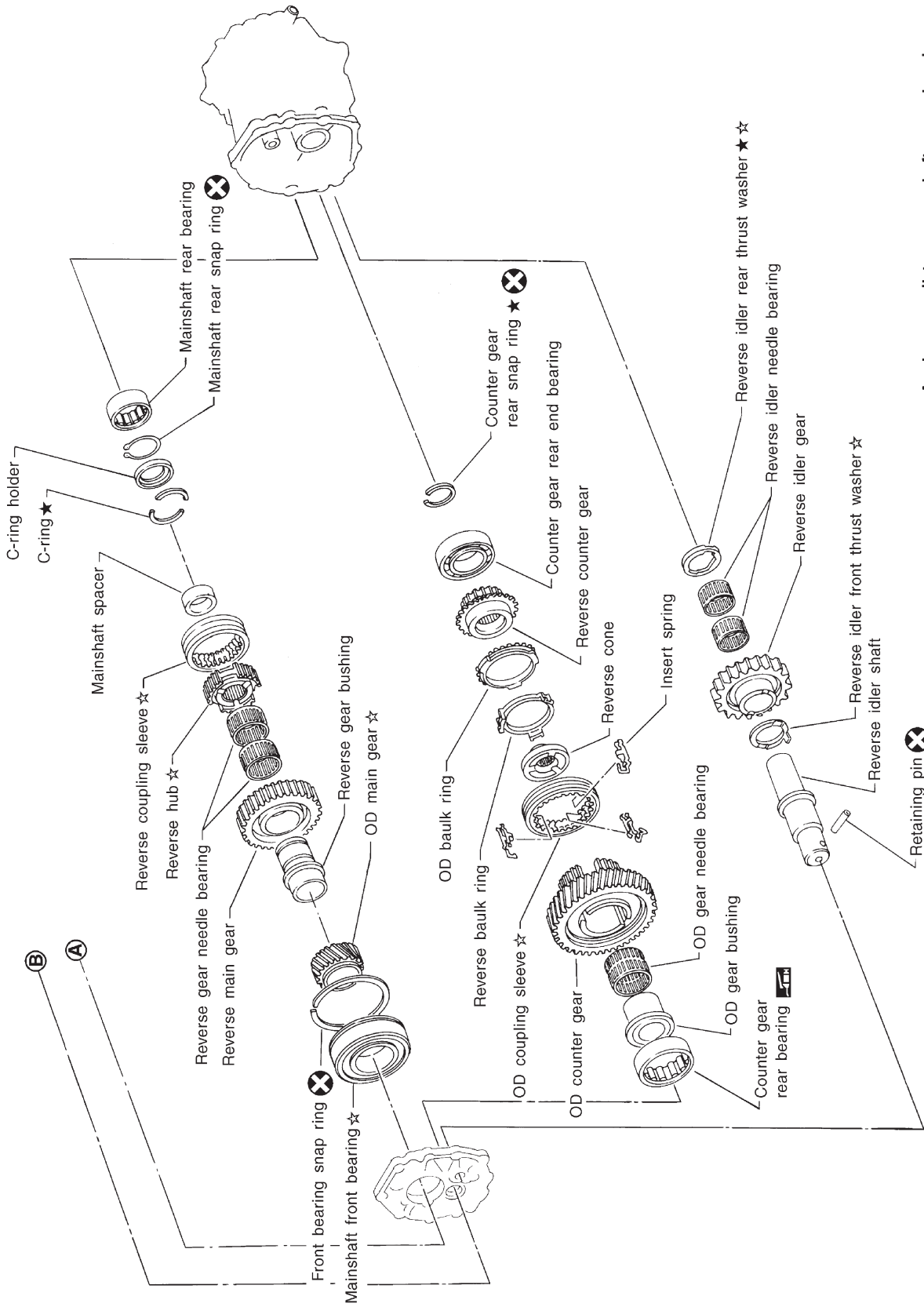



## DISASSEMBLY

### Case Components

1. Remove check ball plug, check spring and check ball. Then remove interlock stopper.

- If interlock assembly is removed as a unit, the check ball can fall into transmission case.
- Be careful not to lose check ball.

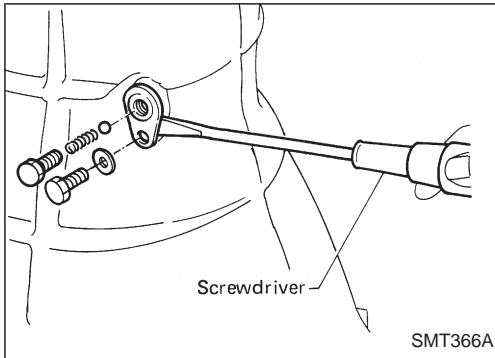

2. Remove control housing, return spring and check ball.

- Be careful not to lose check ball.

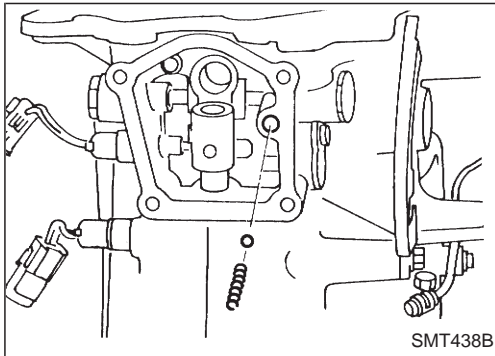

3. Drive out retaining pin from striking arm.

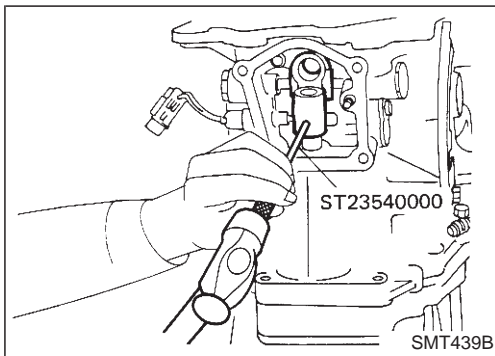

4. Remove OD gear case together with striking arm by tapping lightly.

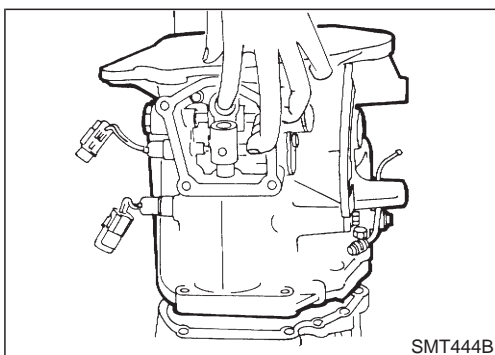
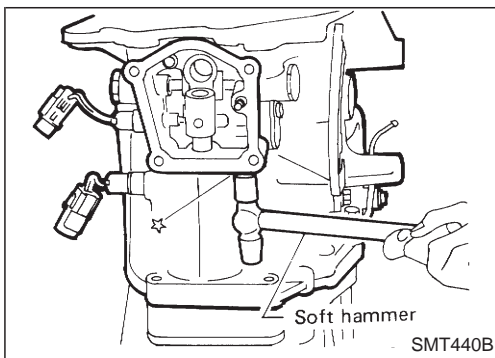

## DISASSEMBLY

### Case Components (Cont'd)

5. Remove front cover and gasket.

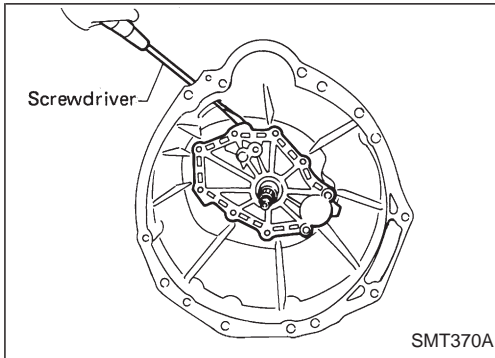

6. Remove stopper ring and main drive bearing snap ring.

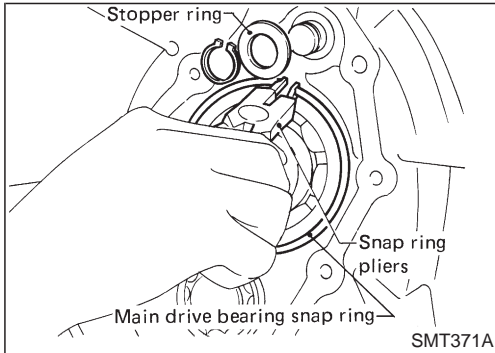

7. Remove transmission case by tapping lightly.

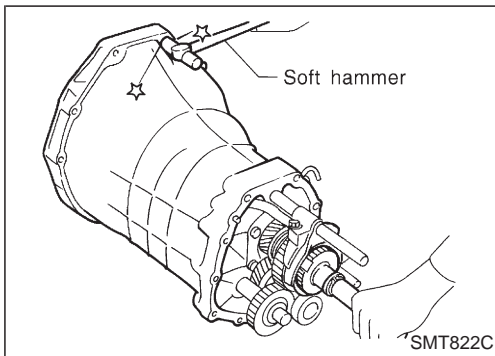

8. Remove front cover oil seal.

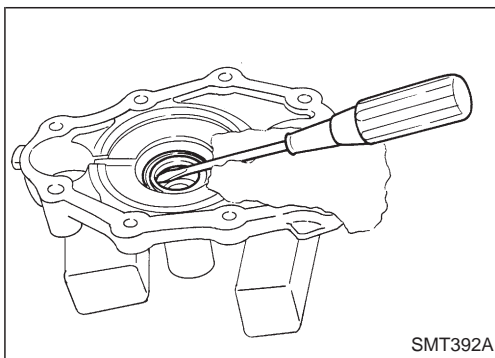

### Shift Control Components

1. Mount adapter plate on vise.
2. Remove OD & reverse fork rod.

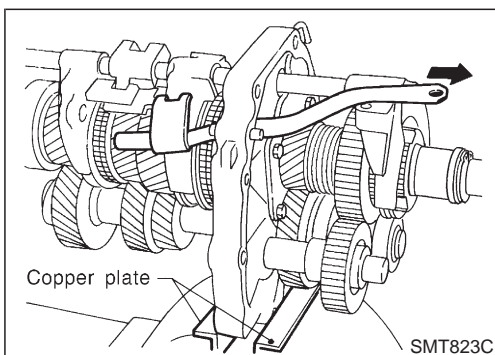

## DISASSEMBLY

### Shift Control Components (Cont'd)

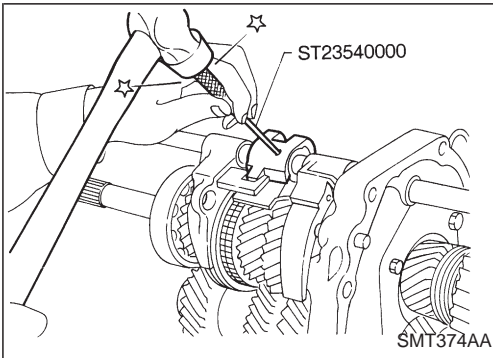

3. Drive out retaining pin from striking lever.
4. While pulling out striking rod, remove striking lever and striking interlock. Then remove 1st & 2nd, 3rd & 4th and reverse shift fork.

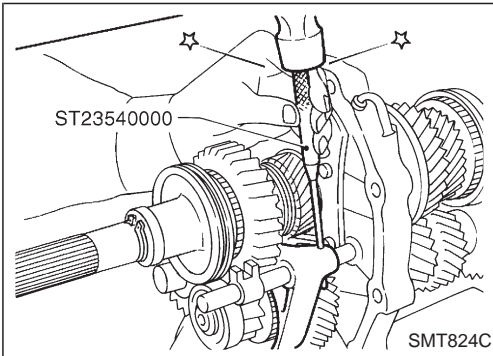

5. Drive out retaining pin from OD shift fork.
6. Pull out OD fork rod and then remove OD shift fork.

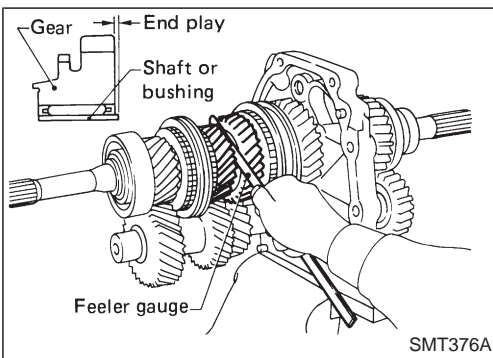

### Gear Components

1. Before removing gears and shafts, measure each gear end play.

#### Gear end play:

Refer to SDS, MT-33.

- If not within specification, disassemble and check contact surface of gear to hub, washer, bushing, needle bearing and shaft.

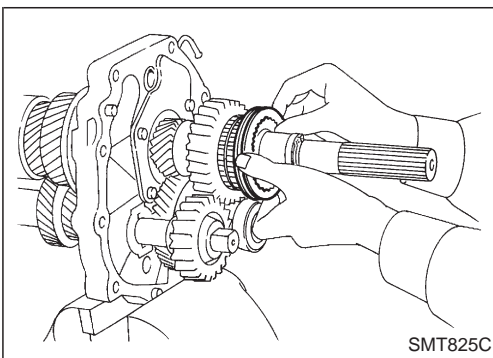

2. Remove rear side components on mainshaft and counter gear.
  - a. Remove reverse coupling sleeve.

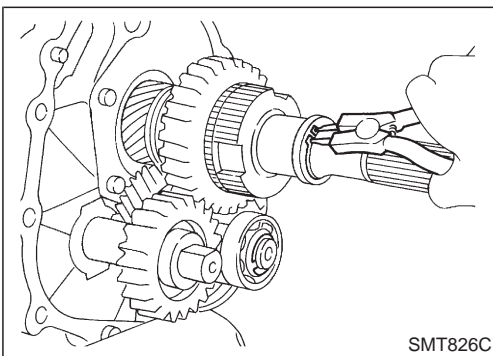

- b. Remove mainshaft rear snap ring and counter gear rear snap ring.
- c. Remove C-ring holder and mainshaft C-rings from mainshaft. Use punch and hammer to remove C-rings.



## DISASSEMBLY

### Gear Components (Cont'd)

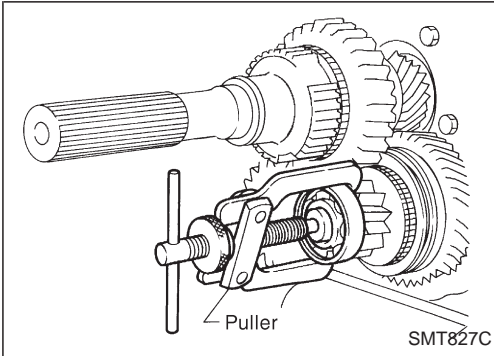

- d. Pull out counter gear rear end bearing.
- e. Remove reverse idler gear and reverse idler thrust washers.

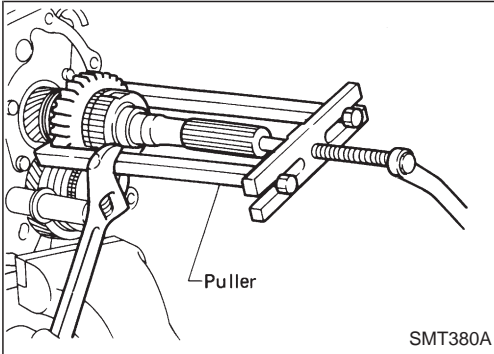

- f. Pull out reverse main gear together with mainshaft spacer and reverse synchronizer hub. Then remove reverse gear needle bearings.

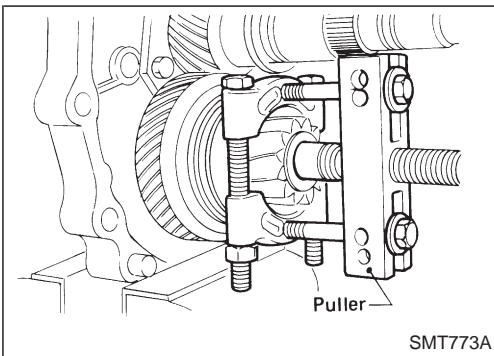

- g. Pull out reverse counter gear.
- h. Remove OD coupling sleeve together with OD baulk ring, reverse baulk ring and spring inserts.

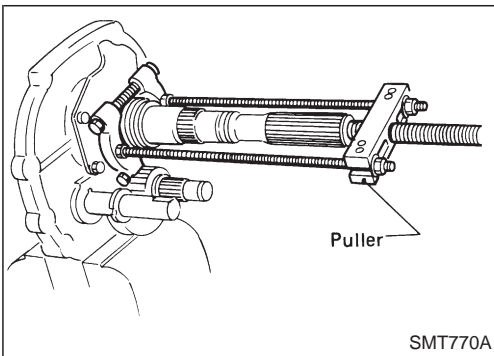

- i. Pull out reverse gear bushing.

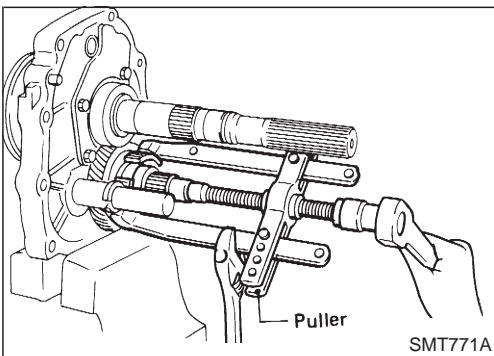

- j. Pull out OD counter gear together with reverse cone.

## DISASSEMBLY

### Gear Components (Cont'd)

3. Press out mainshaft and counter gear alternately.

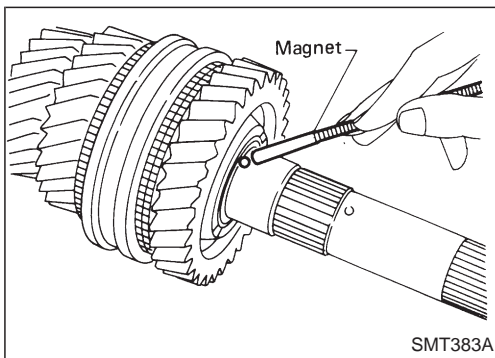
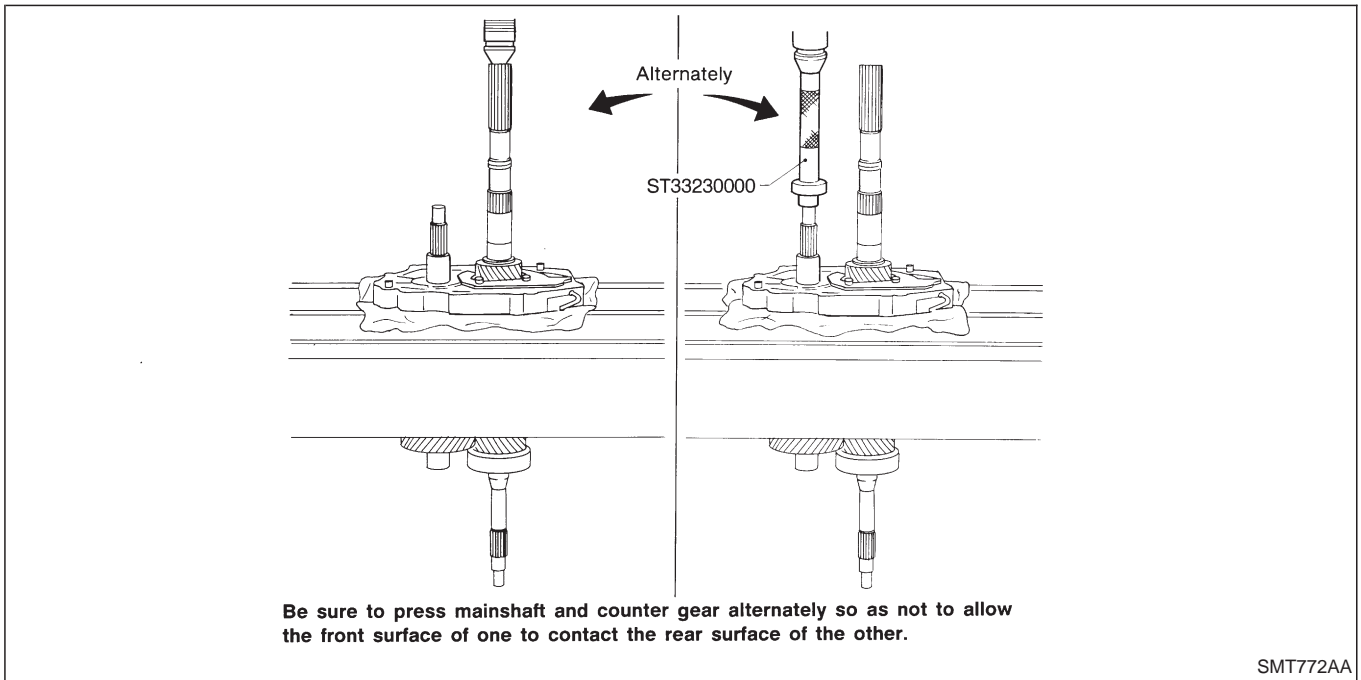

4. Remove front side components on mainshaft.
- a. Remove 1st gear washer and steel ball.
  - b. Remove 1st main gear and 1st gear needle bearing.
  - **Be careful not to lose steel ball.**

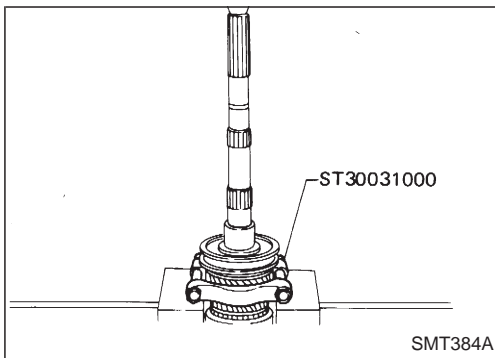

- c. Press out 2nd main gear together with 1st gear bushing and 1st & 2nd synchronizer assembly.
- d. Remove mainshaft front snap ring.

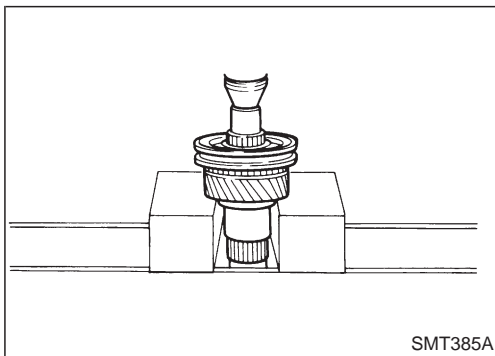

- e. Press out 3rd main gear together with 3rd & 4th synchronizer assembly and 3rd gear needle bearing.

# DISASSEMBLY

## Gear Components (Cont'd)

5. Remove front side components on counter gear.
  - a. Remove counter gear rear thrust bearing.

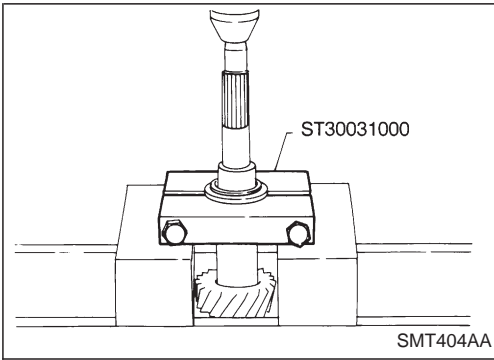

- b. Remove sub gear components.

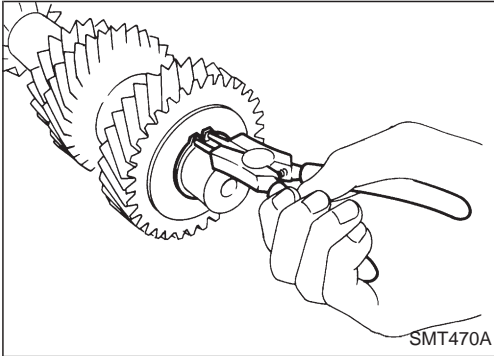

6. Remove main drive gear bearing.
  - a. Remove main drive gear snap ring.
  - b. Press out main drive gear bearing.

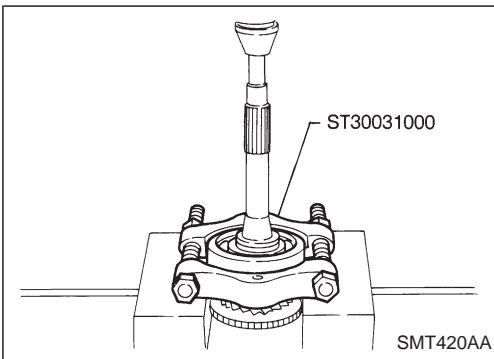

7. Remove bearings from case components.

**Counter gear front bearing in transmission case**

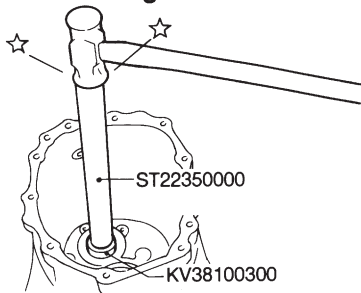

**Mainshaft front bearing in adapter plate**

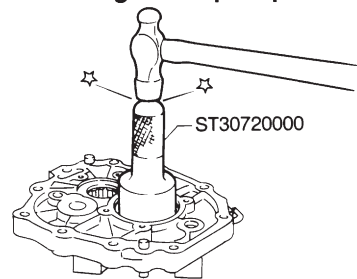

**Mainshaft rear bearing in OD gear case**

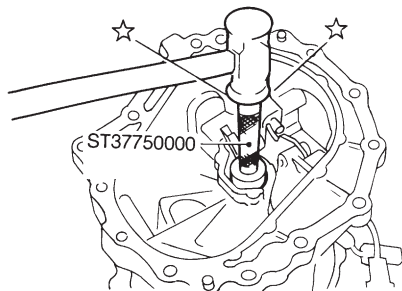

**Counter gear rear bearing in adapter plate**

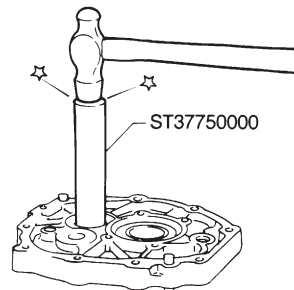

# INSPECTION

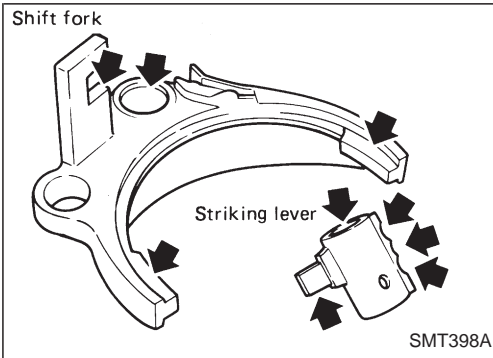

## Shift Control Components

- Check contact surface and sliding surface for wear, scratches, projections or other damage.

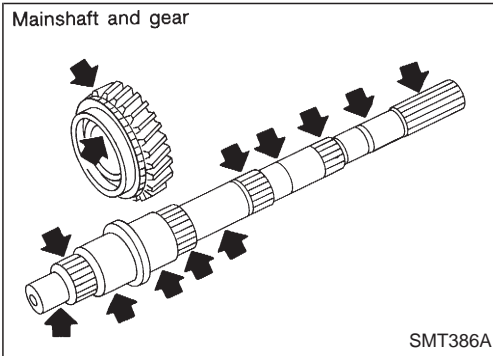

## Gear Components

### GEARS AND SHAFTS

- Check shafts for cracks, wear or bending.
- Check gears for excessive wear, chips or cracks.

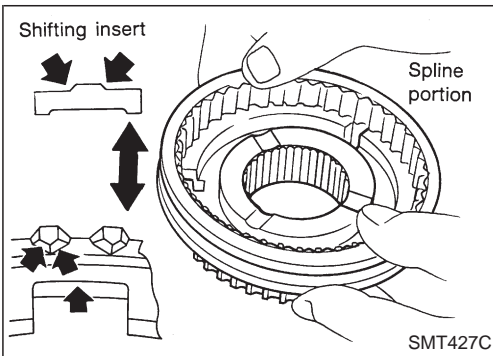
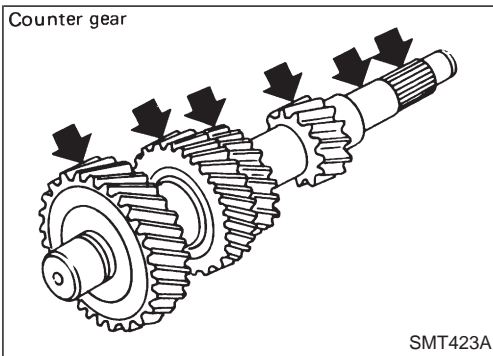

### SYNCHRONIZERS

- Check spline portion of coupling sleeves, hubs, and gears for wear or cracks.
- Check baulk rings for cracks or deformation.
- Check shifting inserts for wear or deformation.
- Check insert springs for deformation.

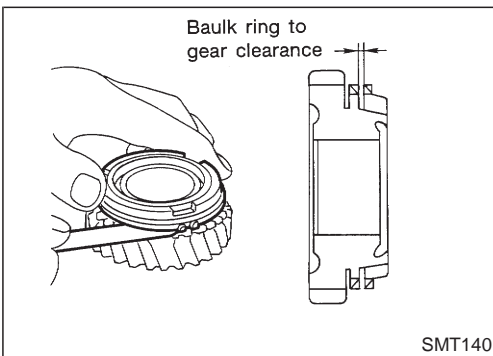

- Measure wear of main drive, 1st and OD baulk rings.  
**Clearance between baulk ring and gear:  
Refer to SDS, MT-33.**
- If the clearance is smaller than the wear limit, replace baulk ring.

## INSPECTION

### Gear Components (Cont'd)

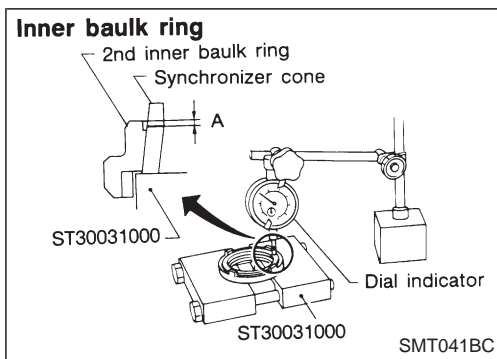

- Measure wear of 2nd and 3rd baulk rings.
  - a. Place baulk rings in position on synchronizer cone.
  - b. While holding baulk rings against synchronizer cone as far as it will go, measure dimensions "A" and "B".

**Standard:**

A 0.7 - 0.9 mm (0.028 - 0.035 in)

B 0.6 - 1.1 mm (0.024 - 0.043 in)

**Wear limit:**

0.2 mm (0.008 in)

- If dimension "A" or "B" is smaller than the wear limit, replace outer baulk ring, inner baulk ring and synchronizer cone as a set.

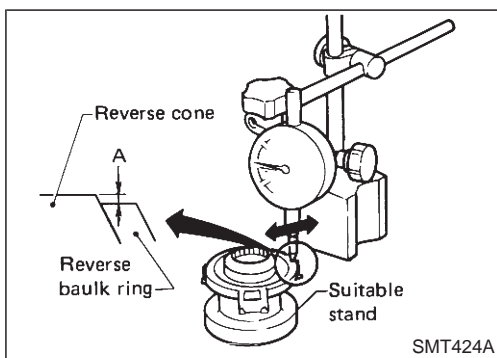
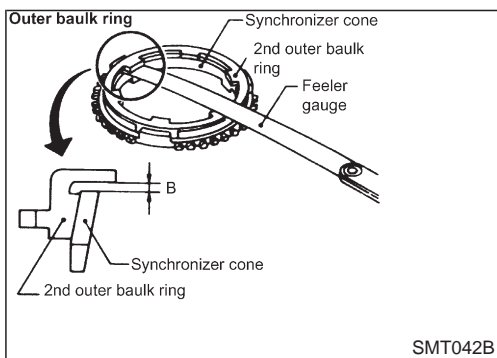

- Measure wear of reverse baulk ring.
  - a. Place baulk ring in position on reverse cone.
  - b. While holding baulk ring against reverse cone as far as it will go, measure dimension "A" with dial indicator.

**Dimension "A":**

**Standard** -0.1 to 0.35 mm (-0.0039 to 0.0138 in)

**Wear limit** 0.7 mm (0.028 in)

- c. If dimension "A" is larger than the wear limit, replace baulk ring.

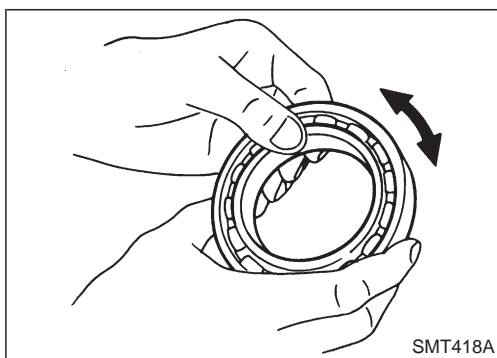

### BEARINGS

- Make sure bearings roll freely and are free from noise, crack, pitting or wear.

# ASSEMBLY

## Gear Components

Counter gear front bearing in transmission case

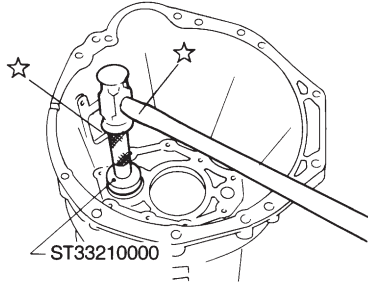

SMT389A

Mainshaft front bearing in adapter plate

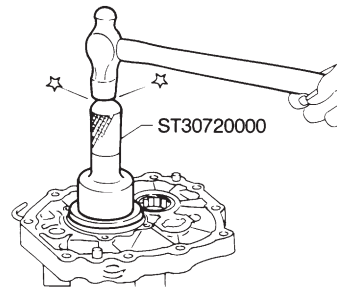

SMT397A

Mainshaft rear bearing in OD gear case

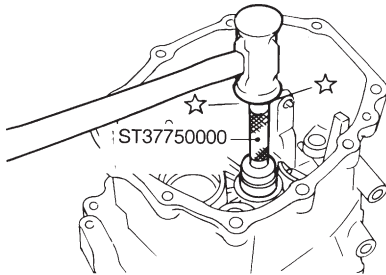

SMT391A

Counter gear rear bearing in adapter plate

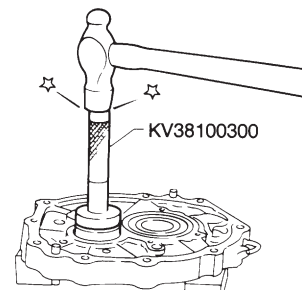

SMT484CB

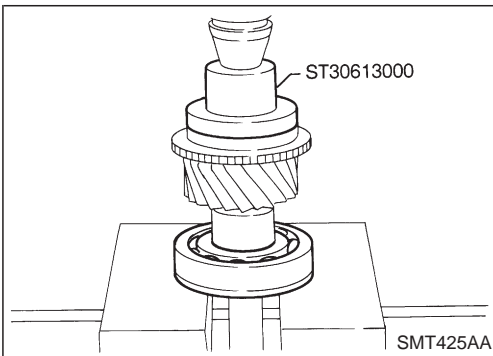

SMT425AA

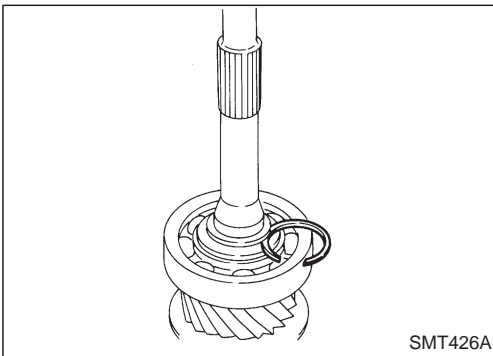

SMT426A

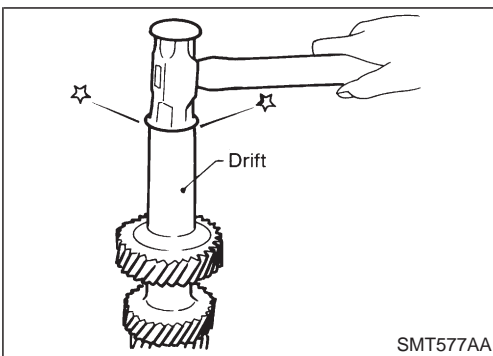

SMT577AA

1. Install bearings into case components.
2. Install main drive gear bearing.
  - a. Press main drive gear bearing.
  - b. Select proper main drive gear snap ring to minimize clearance of groove.
    - Allowable clearance of groove:**  
0 - 0.1 mm (0 - 0.004 in)
    - Main drive gear snap ring:**  
Refer to SDS, MT-33.
  - c. Install selected snap ring on main drive gear.
3. Install components on counter gear.
  - a. Install sub-gear components.
    - **When installing sub-gear snap ring, tap sub-gear snap ring into position on counter gear.**

## ASSEMBLY

### Gear Components (Cont'd)

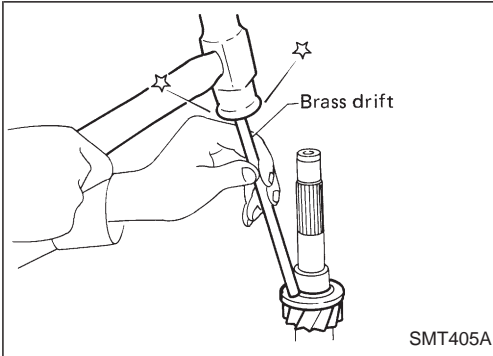

- b. Install counter gear rear thrust bearing.

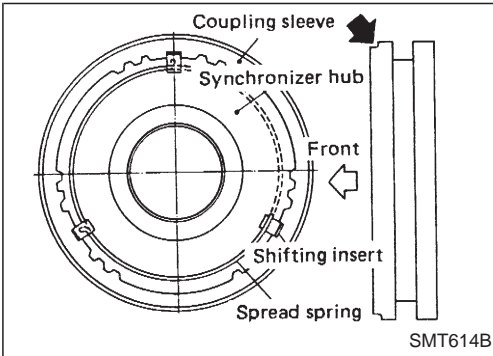

4. Install front side components on mainshaft.  
a. Assemble 1st & 2nd synchronizer.

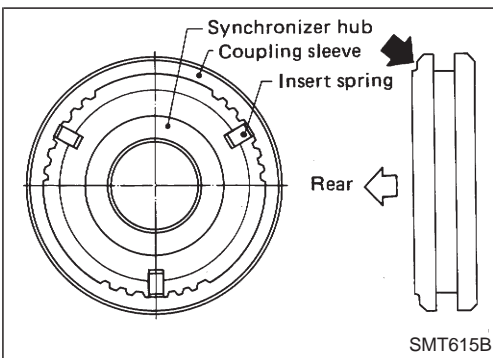

- b. Assemble 3rd & 4th synchronizer.

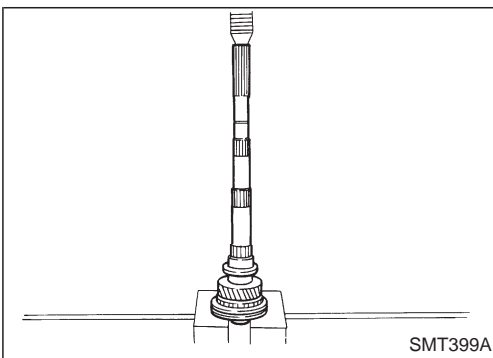

- c. Press on 3rd & 4th synchronizer assembly together with 3rd main gear and 3rd gear needle bearing.  
● **Pay attention to direction of synchronizer assembly.**

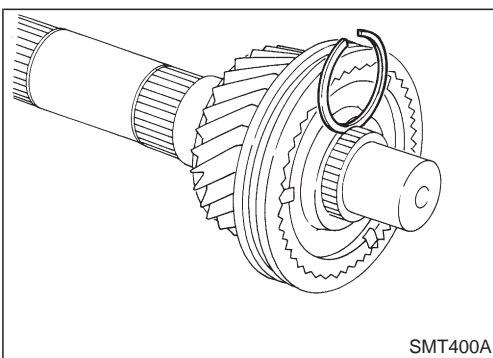

- d. Select proper snap ring to minimize clearance of groove.  
**Allowable clearance of groove:**  
**0 - 0.1 mm (0 - 0.004 in)**  
**Mainshaft front snap ring:**  
**Refer to SDS, MT-33.**  
e. Install selected snap ring on mainshaft.

## ASSEMBLY

### Gear Components (Cont'd)

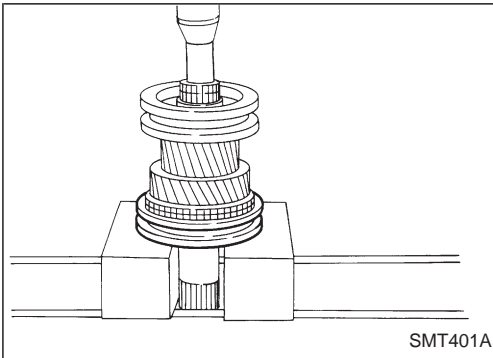

- f. Press on 1st & 2nd synchronizer assembly together with 2nd main gear and 2nd gear needle bearing.

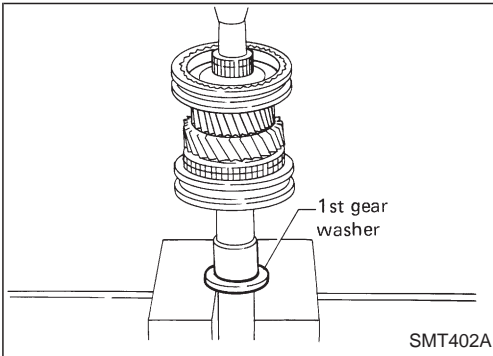

- g. Press on 1st gear bushing using 1st gear washer.  
h. Install 1st main gear and needle bearing.

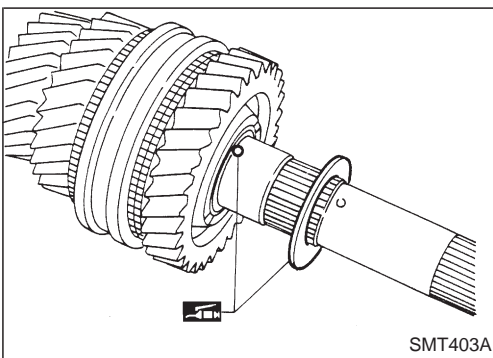

- i. Install steel ball and 1st gear washer.  
● **Apply multi-purpose grease to steel ball and 1st gear washer before installing.**

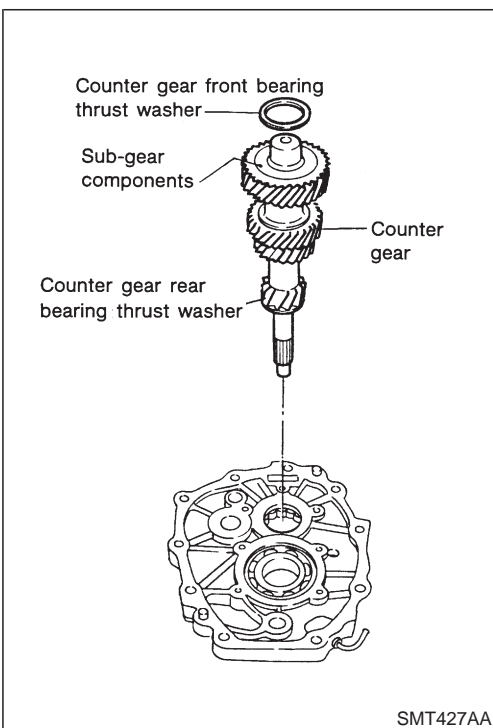

5. Select proper counter gear front bearing thrust washer when replacing transmission case, counter gear, counter gear rear thrust bearing or sub-gear components.  
a. Install counter gear with sub-gear components, counter gear front and rear bearing thrust washer on adapter plate.  
b. Remove counter gear front bearing thrust washer from transmission case.  
c. Place adapter plate and counter gear assembly in transmission case (case inverted).



## ASSEMBLY

### Gear Components (Cont'd)

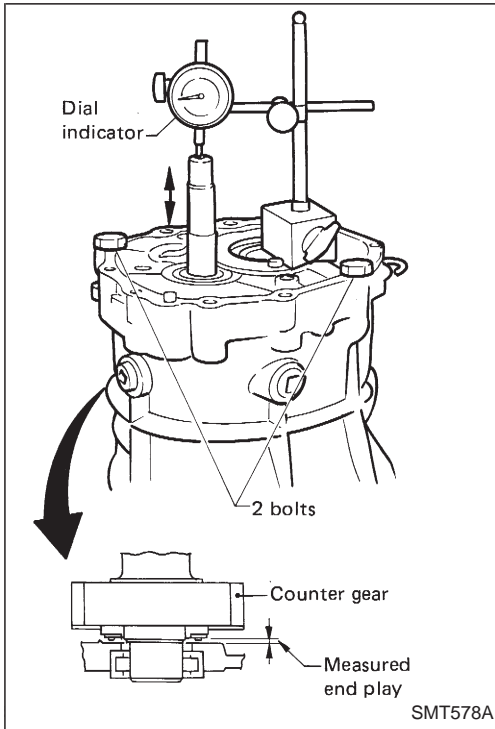

- d. Tighten adapter plate to transmission case using 2 bolts.
- e. Place dial indicator on rear end of counter gear.
- f. Move counter gear up and down and measure dial indicator deflection.
- g. Select proper thrust washer using table below as a guide.

#### Counter gear end play:

0.10 - 0.25 mm (0.0039 - 0.0098 in)

#### Table for selecting proper counter gear front bearing thrust washer:

Refer to SDS, MT-34.

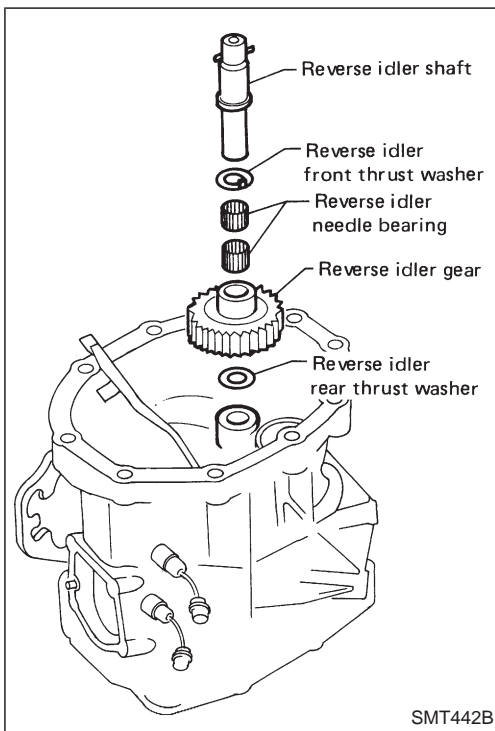

6. Select proper reverse idler rear thrust washer when replacing OD gear case, reverse idler gear, reverse idler shaft or reverse idler front thrust washer.
- a. Install reverse idler front gear, reverse idler needle bearings, reverse idler front thrust washers and reverse idler shaft into OD gear case.
- **When replacing reverse idler rear thrust washer, install either A or B.**

#### Reverse idler rear thrust washer:

Refer to SDS, MT-34.

## ASSEMBLY

### Gear Components (Cont'd)

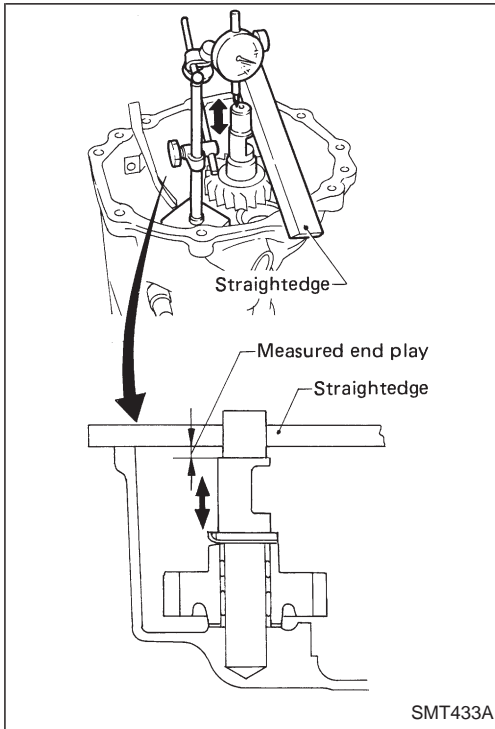

- b. Place dial indicator on front end of reverse idler shaft.
- c. Put straightedge on front surface of OD gear case as a stopper of reverse idler shaft.
- d. Move reverse idler shaft up and down and measure reverse idler gear end play.

#### Reverse idler gear end play:

**0.30 - 0.53 mm (0.0118 - 0.0209 in)**

- e. If not within specification, replace reverse idler rear thrust washer with the other (A or B) and check again.

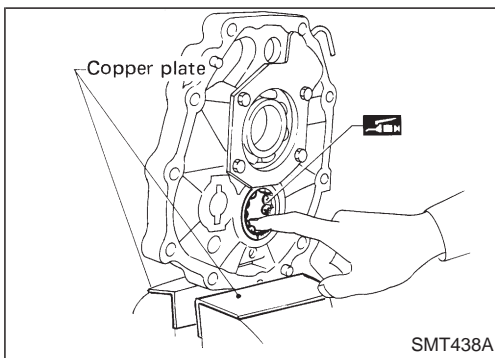

7. Install mainshaft and counter gear on adapter plate and main drive gear on mainshaft.
  - a. Mount adapter plate on vise and apply multi-purpose grease to counter gear rear bearing.

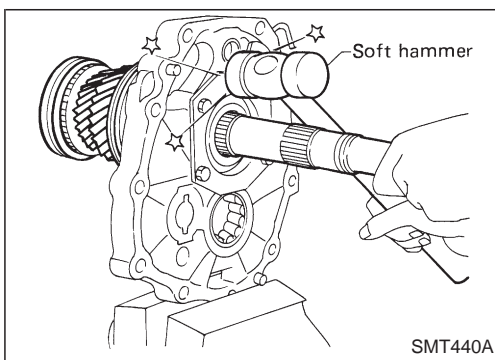

- b. Install mainshaft a little on mainshaft front bearing.
  - **To allow for installation of counter gear, do not install mainshaft completely.**

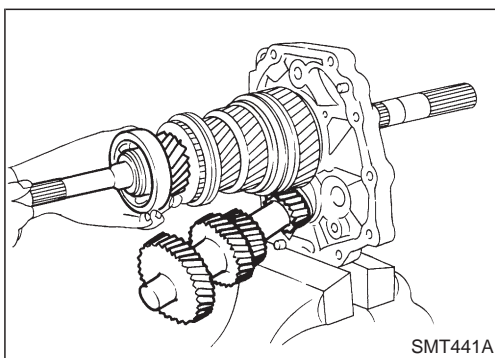

- c. Install counter gear on counter gear rear bearing and install main drive gear, pilot bearing and spacer on mainshaft.

## ASSEMBLY

### Gear Components (Cont'd)

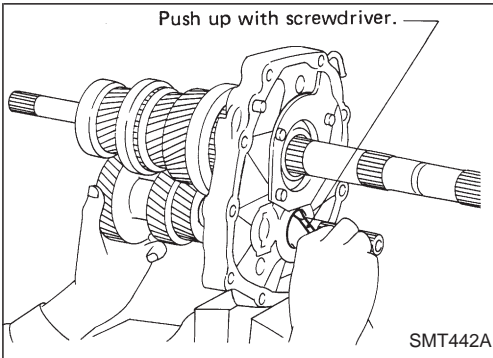

- When installing counter gear into counter gear rear bearing, push up on upper roller of counter gear rear bearing with screwdriver.

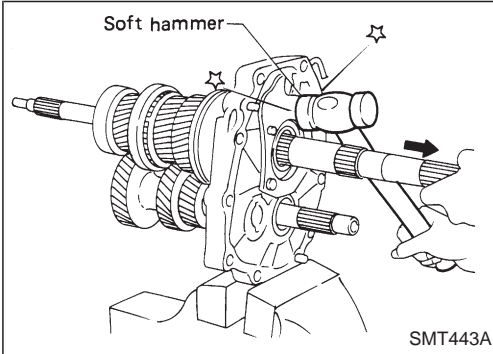

- d. Install mainshaft and counter gear completely by tapping rear side of adapter plate and pulling mainshaft.

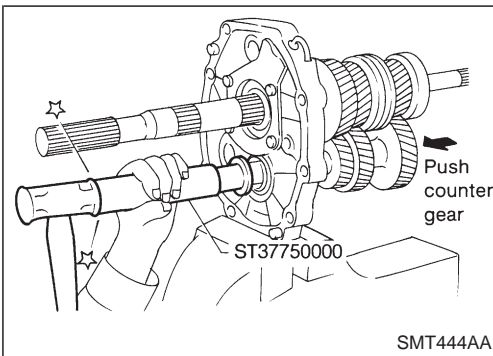

8. Install rear side components on mainshaft and counter gear.
  - a. Install OD gear bushing while pushing on the front of counter gear.

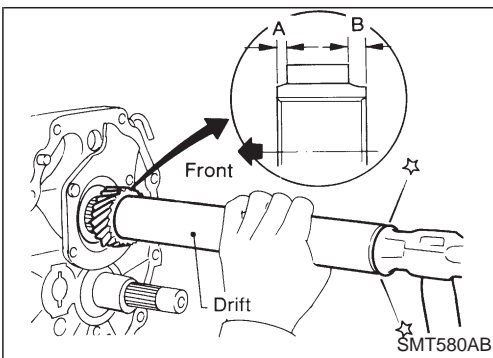

- b. Install OD main gear.
  - Pay attention to direction of OD main gear. (B is wider than A as shown at left.)
- c. Install adapter plate with gear assembly onto transmission case.
- d. Install OD gear needle bearing and then install OD counter gear and reverse idler shaft.

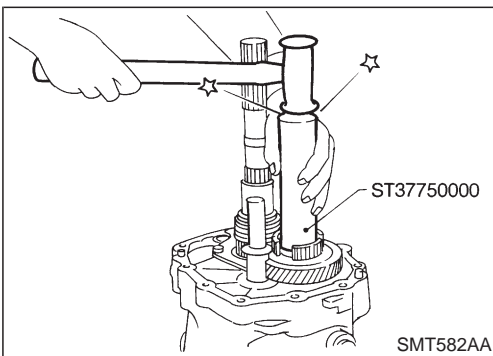

- e. Install reverse cone.

## ASSEMBLY

### Gear Components (Cont'd)

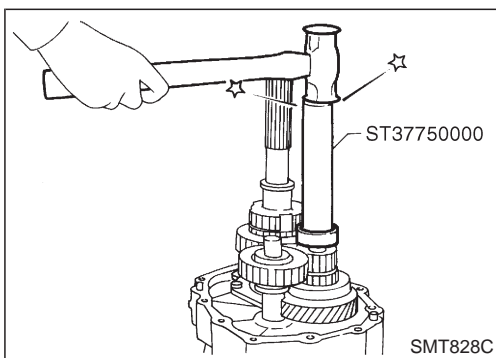
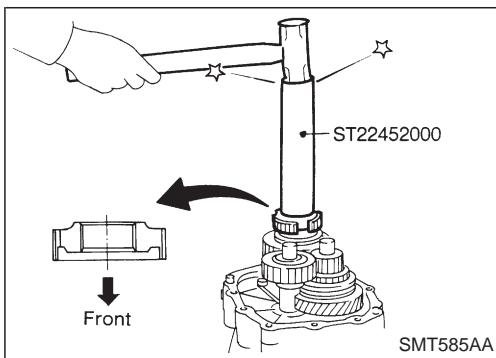
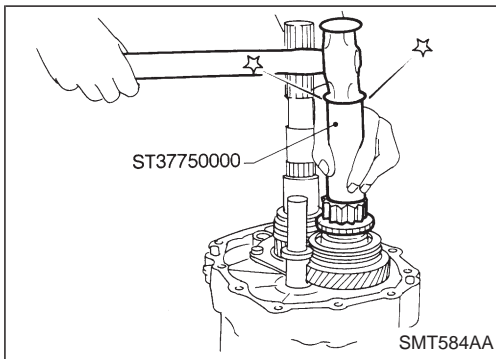
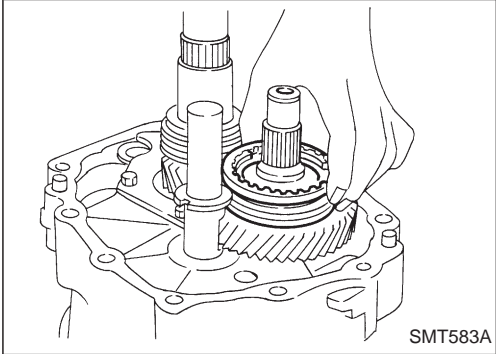
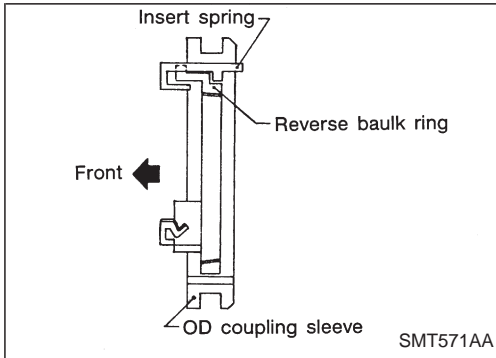

f. Install insert springs and reverse baulk ring on OD coupling sleeve. Then install them and OD baulk ring on OD counter gear.

- Pay attention to direction of OD coupling sleeve.

g. Install reverse counter gear.

h. Install reverse gear needle bearing and then install reverse main gear, reverse idler gear and reverse idler thrust washers.

i. Install reverse hub and mainshaft spacer.

- Pay attention to direction of reverse hub.

j. Install counter gear rear end bearing.

k. Separate adapter plate from transmission case and mount adapter plate on vice again.

## ASSEMBLY

### Gear Components (Cont'd)

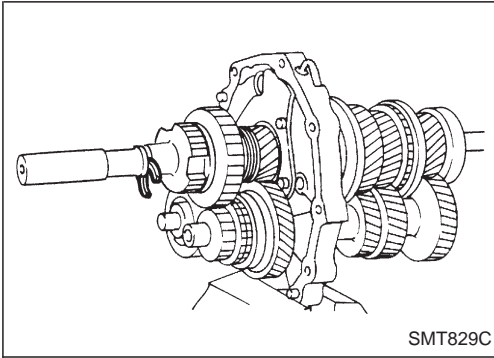

- l. Select proper mainshaft C-ring to minimize clearance of groove.

**Allowable clearance of groove:**

**0 - 0.1 mm (0 - 0.004 in)**

**Mainshaft C-ring:**

**Refer to SDS, MT-34.**

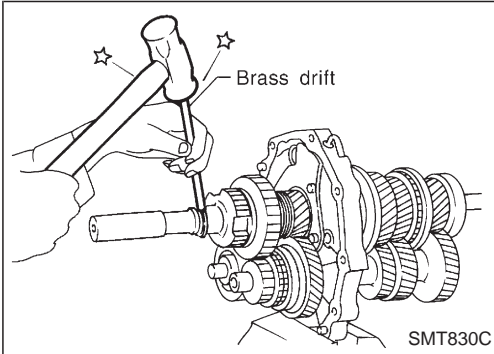

- m. Install selected C-ring, C-ring holder and mainshaft rear snap ring.

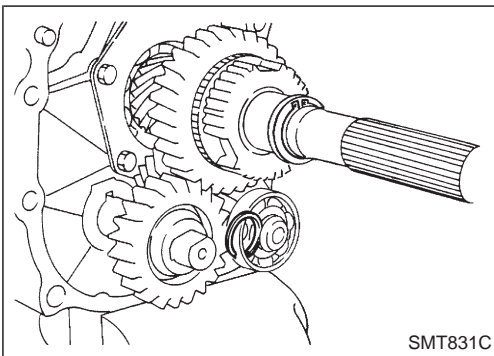

- n. Select proper counter gear rear snap ring to minimize clearance of groove.

**Allowable clearance of groove:**

**0 - 0.1 mm (0 - 0.004 in)**

**Counter gear rear snap ring:**

**Refer to SDS, MT-34.**

- o. Install selected counter gear rear snap ring.

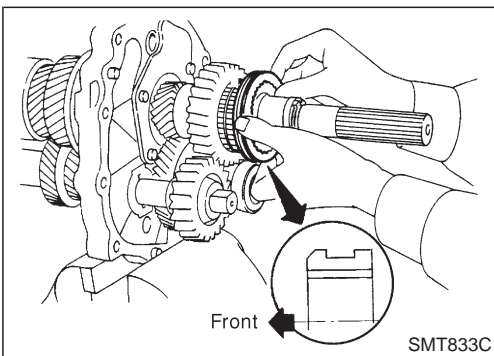
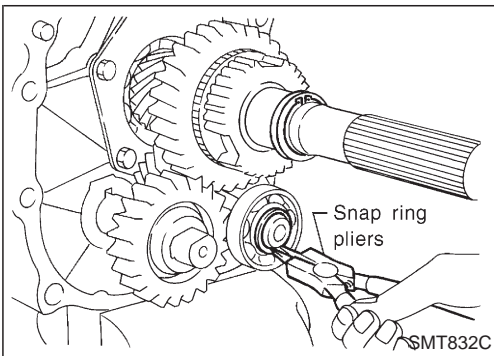

- p. Install reverse coupling sleeve.

● **Pay attention to its direction.**

- q. Measure each gear end play as a final check. Refer to "DISASSEMBLY", MT-15.



## ASSEMBLY

### Case Components (Cont'd)

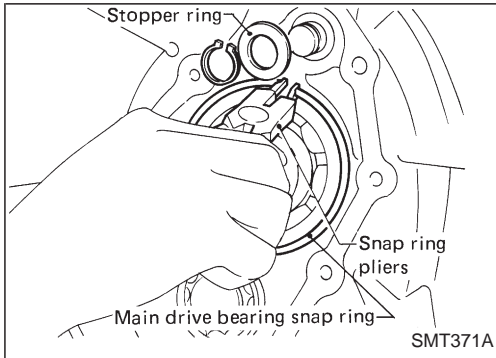

7. Install stopper ring and main drive bearing snap ring.

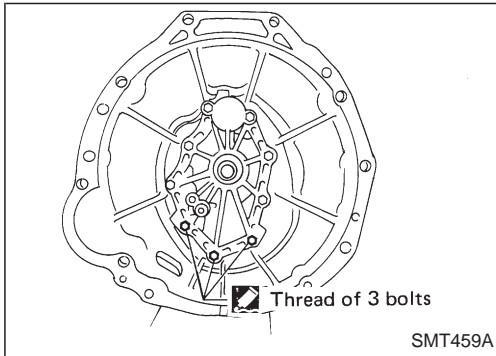

8. Install front cover and gasket.

● **Apply sealant to thread of 3 bolts shown left.**

9. Apply sealant to mating surface of adapter plate.

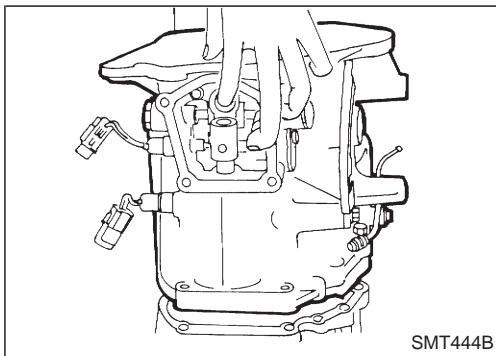

10. Install OD gear case together with striking arm.

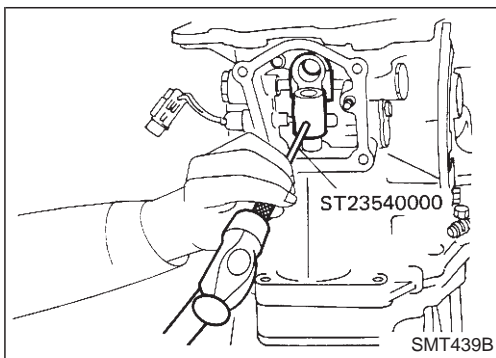

11. Install retaining pin into striking arm.

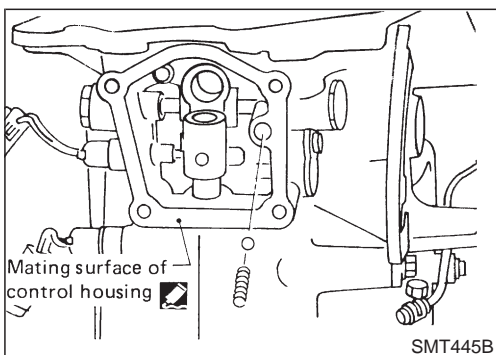

12. Install return spring and check ball and then install control housing.

● **Apply sealant to mating surface of OD gear case.**

## ASSEMBLY

### Case Components (Cont'd)

13. Tighten control housing bolts.

**Bolt head size:**

**A bolts 12 mm (0.47 in)**

**B bolts 13 mm (0.51 in)**

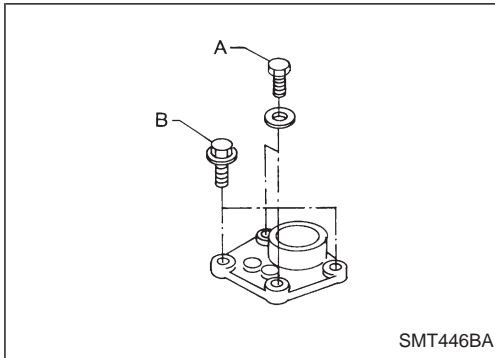



# SERVICE DATA AND SPECIFICATIONS (SDS)

## General Specifications

Applied model	RD28ETi
	4WD
Transmission	FS5R30A
Number of speed	5
Transmission control	Floor direct
Shift pattern	
Synchromesh type	Warner
Gear ratio	
1st	4.061
2nd	2.357
3rd	1.490
4th	1.000
OD	0.862
Reverse	4.125
Number of teeth	
Mainshaft	
Drive	20
1st	32
2nd	30
3rd	28
OD	23
Reverse	30
Countershaft	
Drive	33
1st	13
2nd	21
3rd	31
OD	44
Reverse	12
Reverse idler gear	22
Oil capacity ℓ (Imp pt)	5.1 (9)
Remarks	2nd & 3rd double baulk ring type synchronizer
	Reverse breaking mechanism type

# SERVICE DATA AND SPECIFICATIONS (SDS)

## Inspection and Adjustment

### GEAR END PLAY

Gear	End play mm (in)
1st main gear	0.23 - 0.33 (0.0091 - 0.0130)
2nd main gear	0.23 - 0.33 (0.0091 - 0.0130)
3rd main gear	0.06 - 0.16 (0.0024 - 0.0063)
OD counter gear	0.23 - 0.33 (0.0091 - 0.0130)
Reverse main gear	0.33 - 0.43 (0.0130 - 0.0169)
Counter gear	0.10 - 0.25 (0.0039 - 0.0098)
Reverse idler gear	0.30 - 0.53 (0.0118 - 0.0209)

### CLEARANCE BETWEEN BAULK RING AND GEAR

Unit: mm (in)

	Standard	Wear limit
1st	1.05 - 1.3 (0.0413 - 0.0512)	0.7 (0.028)
Main drive	1.05 - 1.3 (0.0413 - 0.0512)	
OD	1.05 - 1.3 (0.0413 - 0.0512)	

### 2nd and 3rd baulk ring

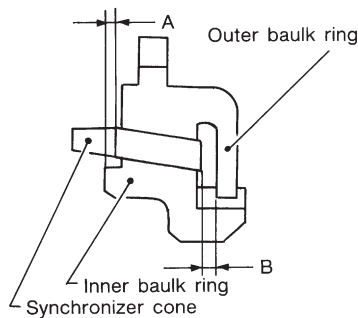

SMT742C

Unit: mm (in)

Dimension	Standard	Wear limit
A	0.7 - 0.9 (0.028 - 0.035)	0.2 (0.008)
B	0.6 - 1.1 (0.024 - 0.043)	

### DISTANCE BETWEEN REAR SURFACE OF REVERSE CONE AND REVERSE BAULK RING

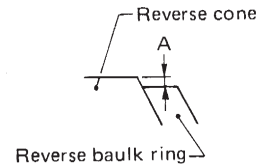

Unit: mm (in)

	Standard	Wear limit
Dimension "A"	-0.1 to 0.35 (-0.0039 to 0.0138)	0.7 (0.028)

### AVAILABLE SNAP RING

#### Main drive gear snap ring

Allowable clearance		0 - 0.1 mm (0 - 0.004 in)
Thickness mm (in)	Part number	
1.89 (0.0744)	32204-01G60	
1.95 (0.0768)	32204-01G61	
1.99 (0.0783)	32204-01G62	
2.03 (0.0799)	32204-01G63	
2.07 (0.0815)	32204-01G64	
2.11 (0.0831)	32204-01G65	

#### Mainshaft front snap ring

Allowable clearance		0 - 0.1 mm (0 - 0.004 in)
Thickness mm (in)	Part number	
1.99 (0.0783)	32204-01G62	
2.03 (0.0799)	32204-01G63	
2.07 (0.0815)	32204-01G64	
2.11 (0.0831)	32204-01G65	
2.15 (0.0846)	32204-01G66	
2.19 (0.0862)	32204-01G67	

# SERVICE DATA AND SPECIFICATIONS (SDS)

## Inspection and Adjustment (Cont'd)

### Counter gear rear snap ring

Allowable clearance		0 - 0.1 mm (0 - 0.004 in)
Thickness	mm (in)	Part number
1.32	(0.0520)	32236-01G00
1.38	(0.0543)	32236-01G01
1.44	(0.0567)	32236-01G02
1.50	(0.0591)	32236-01G03
1.56	(0.0614)	32236-01G04
1.62	(0.0638)	32236-01G05
1.68	(0.0661)	32236-01G06
1.74	(0.0685)	32236-01G07

### AVAILABLE C-RING

#### Mainshaft C-ring

Allowable clearance		0 - 0.1 mm (0 - 0.004 in)
Thickness	mm (in)	Part number
2.63	(0.1035)	32348-01G15
2.70	(0.1063)	32348-01G00
2.77	(0.1091)	32348-01G01
2.84	(0.1118)	32348-01G02
2.91	(0.1146)	32348-01G03
2.98	(0.1173)	32348-01G04
3.05	(0.1201)	32348-01G05
3.12	(0.1228)	32348-01G06
3.19	(0.1256)	32348-01G07
3.26	(0.1283)	32348-01G08
3.33	(0.1311)	32348-01G09
3.40	(0.1339)	32348-01G10
3.47	(0.1366)	32348-01G11
3.54	(0.1394)	32348-01G12
3.61	(0.1421)	32348-01G13
3.68	(0.1449)	32348-01G14

### AVAILABLE SHIM AND WASHER

#### Table for selecting proper counter gear front bearing thrust washer

Dial indicator deflection mm (in)	Thickness of proper washer mm (in)	Part number
0.93 - 1.02 (0.0366 - 0.0402)	0.80 (0.0315)	32218-01G00
1.01 - 1.10 (0.0398 - 0.0433)	0.88 (0.0346)	32218-01G11
1.09 - 1.18 (0.0429 - 0.0465)	0.96 (0.0378)	32218-01G12
1.17 - 1.26 (0.0461 - 0.0496)	1.04 (0.0409)	32218-01G13
1.25 - 1.34 (0.0492 - 0.0528)	1.12 (0.0441)	32218-01G14
1.33 - 1.42 (0.0524 - 0.0559)	1.20 (0.0472)	32218-01G04
1.41 - 1.50 (0.0555 - 0.0591)	1.28 (0.0504)	32218-01G15
1.49 - 1.58 (0.0587 - 0.0622)	1.36 (0.0535)	32218-01G16
1.57 - 1.66 (0.0618 - 0.0654)	1.44 (0.0567)	32218-01G17

#### Reverse idler rear thrust washer

Thickness		mm (in)	Part number
A	1.97	(0.0776)	32284-01G10
B	2.07	(0.0815)	32284-01G11