

SECTION **TF**

CONTENTS

PREPARATION	1	Shift Control Components	12
Special Service Tools	1	DISASSEMBLY	13
Commercial Service Tools	2	REPAIR FOR COMPONENT PARTS	19
NOISE, VIBRATION AND HARSHNESS (NVH)		Mainshaft	19
TROUBLESHOOTING	3	Front Drive Shaft	20
NVH Troubleshooting Chart.....	3	Counter Gear	21
DESCRIPTION	4	Main Gear	22
Cross-sectional View	4	Front Case	24
ON-VEHICLE SERVICE	5	Front Case Cover	24
Replacing Oil Seal	5	Center Case.....	24
Checking Position Switch	7	Bearing Retainer	25
REMOVAL AND INSTALLATION	8	Rear Case.....	25
Removal.....	8	Shift Control Components	26
Installation.....	8	ASSEMBLY	27
TRANSFER GEAR CONTROL	9	SERVICE DATA AND SPECIFICATIONS (SDS)	33
MAJOR OVERHAUL	10	General Specifications.....	33
Case Components	10	Inspection and Adjustment	33
Gear Components	11		

PREPARATION

Special Service Tools

*: Special tool or commercial equivalent

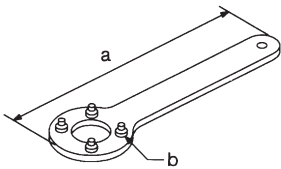
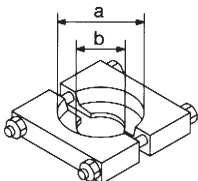
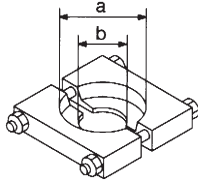
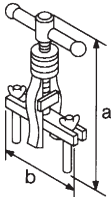
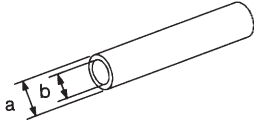
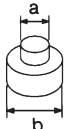
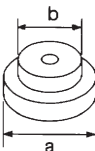
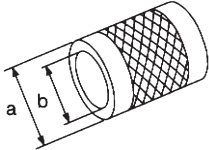
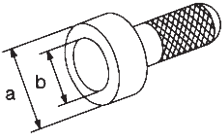
Tool number Tool name	Description	
KV38104700* Flange wrench	 NT428	Removing front companion flange nut Installing front companion flange nut
ST30021000* Puller	 NT411	Removing counter gear front bearing
ST30031000* Puller	 NT411	Removing counter gear rear bearing
ST33290001* Puller	 NT414	Removing center case oil seal Removing rear oil seal
ST22452000* Drift	 NT065	Installing mainshaft rear bearing a: 45 mm (1.77 in) dia. b: 36 mm (1.42 in) dia.
ST33061000* Drift	 NT116	Removing main gear bearing a: 28.5 mm (1.122 in) dia. b: 38 mm (1.50 in) dia.
ST30613000* Drift	 NT073	Installing counter gear rear bearing Installing main gear bearing Installing cover oil seal a: 72 mm (2.83 in) dia. b: 48 mm (1.89 in) dia.
ST33200000* Drift	 NT091	Installing counter gear front bearing Removing cover oil seal a: 60 mm (2.36 in) dia. b: 44.5 mm (1.752 in) dia.
ST30720000* Drift	 NT115	Installing counter case oil seal a: 77 mm (3.03 in) dia. b: 55.5 mm (2.185 in) dia.

PREPARATION

Commercial Service Tools

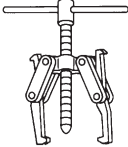
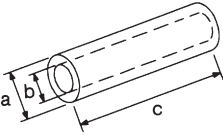
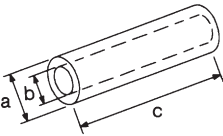
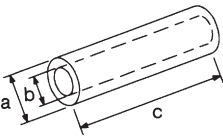
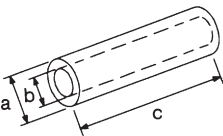
Tool name	Description
Puller	<div style="text-align: center;">  </div> <p style="text-align: center;">NT077</p> <p>Removing front and rear companion flanges Removing mainshaft rear bearing and clutch gear Removing L & H hub Removing front drive shaft front bearing Removing front drive shaft rear bearing Removing main gear bearing</p>
Drift	<div style="text-align: center;">  </div> <p style="text-align: center;">NT117</p> <p>Installing shift shaft oil seal</p> <p>a: 26 mm (1.02 in) dia. b: 20 mm (0.79 in) dia. c: 40 mm (1.57 in)</p>
Drift	<div style="text-align: center;">  </div> <p style="text-align: center;">NT117</p> <p>Installing L & H hub</p> <p>a: 60 mm (2.36 in) dia. b: 50 mm (1.97 in) dia. c: 60 mm (2.36 in)</p>
Drift	<div style="text-align: center;">  </div> <p style="text-align: center;">NT117</p> <p>Installing clutch gear</p> <p>a: 55 mm (2.17 in) dia. b: 45 mm (1.77 in) dia. c: 160 mm (6.30 in)</p>
Drift	<div style="text-align: center;">  </div> <p style="text-align: center;">NT117</p> <p>Installing rear oil seal</p> <p>a: 75 mm (2.95 in) dia. b: 67 mm (2.64 in) dia. c: 60 mm (2.36 in)</p>

NOISE, VIBRATION AND HARSHNESS (NVH) TROUBLESHOOTING

NVH Troubleshooting Chart

Use the chart below to help you find the cause of the problem. The numbers indicate the order of the inspection. If necessary, repair or replace these parts.

TRANSFER

Symptom		SUSPECTED PARTS (Possible cause)											Reference page	
		FLUID (Level low)	FLUID (Wrong)	FLUID (Level too high)	LIQUID GASKET (Damaged)	OIL SEAL (Worn or damaged)	CHECK SPRING AND CHECK BALL (Worn or damaged)	SHIFT FORK (Worn)	GEAR (Worn or damaged)	BEARING (Worn or damaged)	BAULK RING (Worn or damaged)	SHIFTING INSERT (Damaged)		
Noise	1												Refer to MA section ("Checking Transfer Fluid", "CHASSIS AND BODY MAINTENANCE").	TF-10 TF-10 TF-10, TF-12 TF-12 TF-11 TF-11 TF-11 TF-11
	2													
	3													
	3													
Fluid leakage	3													
	1													
Hard to shift or will not shift	1													
	1													
Jumps out of gear	1													
	2													
Jumps out of gear	2													
	2													

ON-VEHICLE SERVICE

Replacing Oil Seal

CENTER CASE OIL SEAL

1. Remove front propeller shaft. Refer to PD section ("Removal and Installation", "PROPELLER SHAFT").
2. Remove companion flange nut.

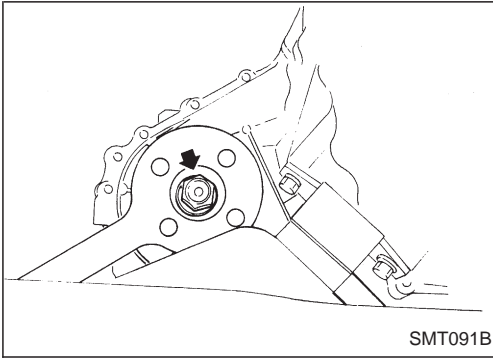

3. Remove front companion flange.

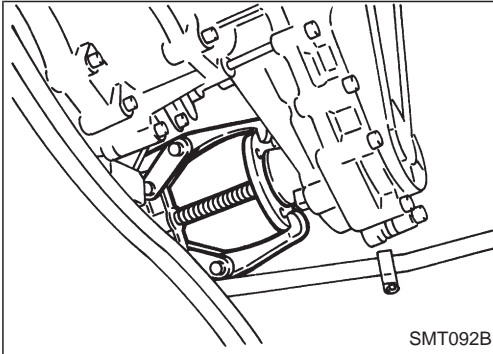

4. Remove center case oil seal.

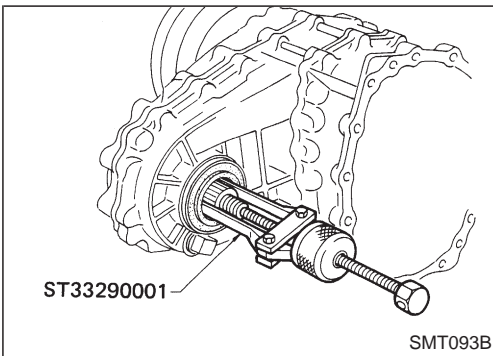

5. Install center case oil seal.
 - **Before installing, apply multi-purpose grease to seal lip.**
6. Reinstall any part removed.

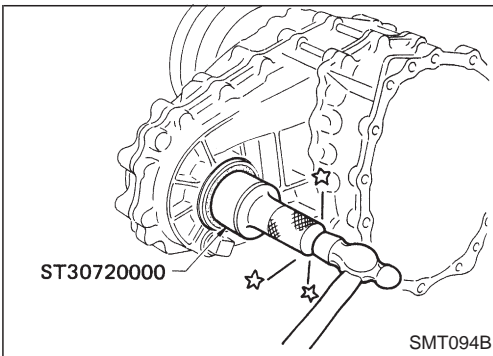

SHIFT SHAFT OIL SEAL

1. Remove transfer control lever from transfer cross shaft.

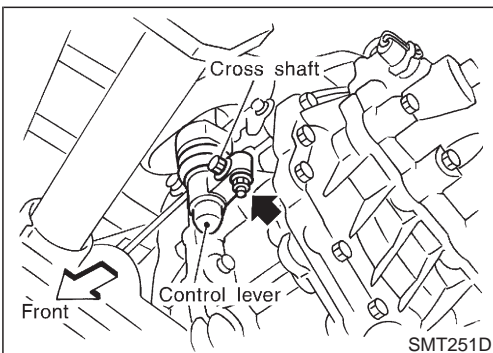

ON-VEHICLE SERVICE

Replacing Oil Seal (Cont'd)

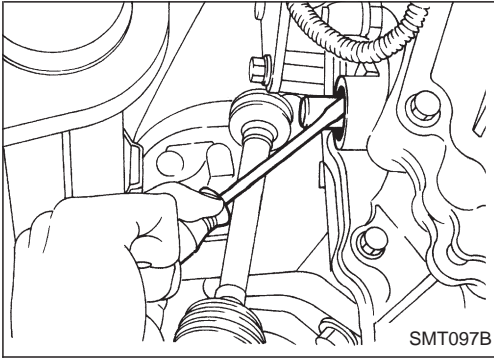

2. Remove shift shaft oil seal.
 - **Be careful not to damage inner shift lever.**

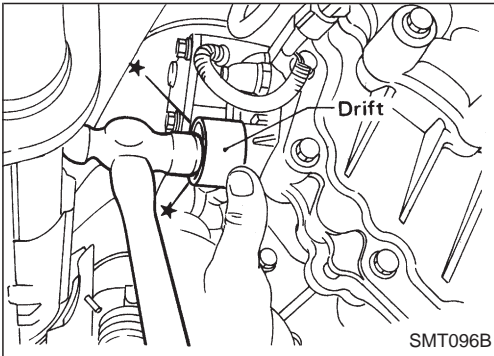

3. Install shift shaft oil seal.
 - **Before installing, apply multi-purpose grease to seal lip.**
4. Install transfer control lever.

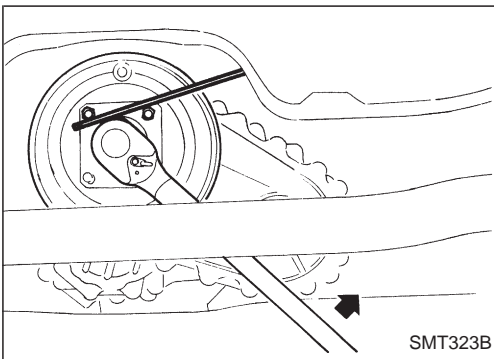

REAR OIL SEAL

1. Remove rear propeller shaft. Refer to PD section ("Removal and Installation", "PROPELLER SHAFT").
2. Remove brake drum.
3. Remove companion flange nut.
4. Remove rear companion flange.
5. Remove center brake assembly.

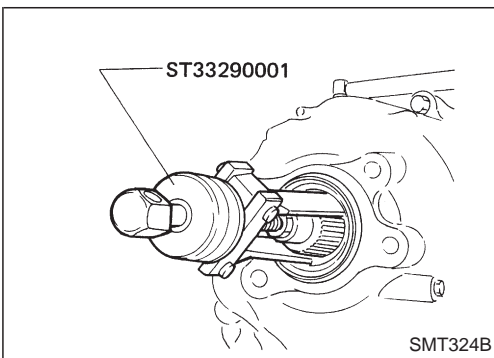

6. Remove rear oil seal.

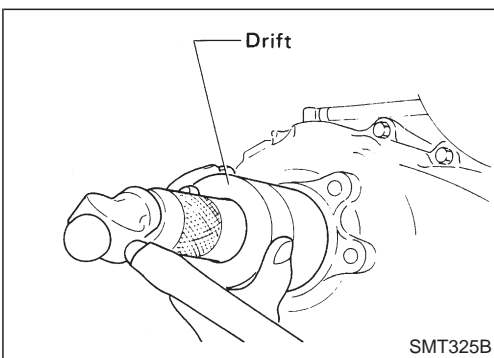

7. Install rear oil seal.
 - **Before installing, apply multi-purpose grease to seal lip.**
8. Reinstall any part removed.

ON-VEHICLE SERVICE

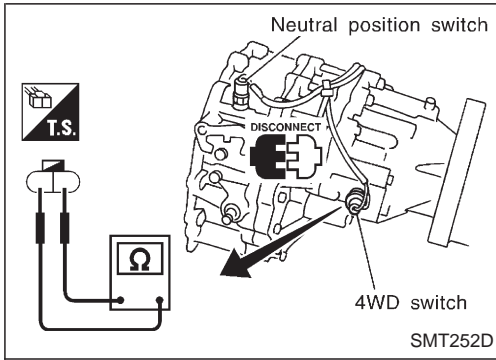

Checking Position Switch

4WD SWITCH

Transfer control lever position	Continuity
4H, 4L	Yes
Except above	No

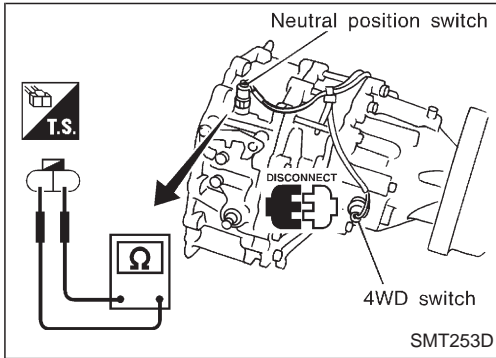

NEUTRAL POSITION SWITCH

Transfer control lever position	Continuity
Between 4H and 4L ("PUSH" position)	Yes
Except above	No

REMOVAL AND INSTALLATION

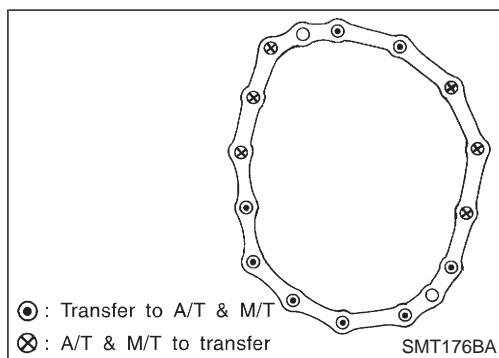
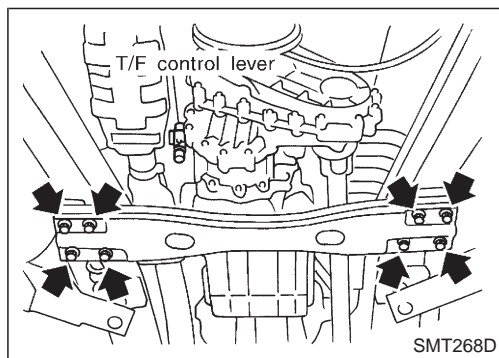
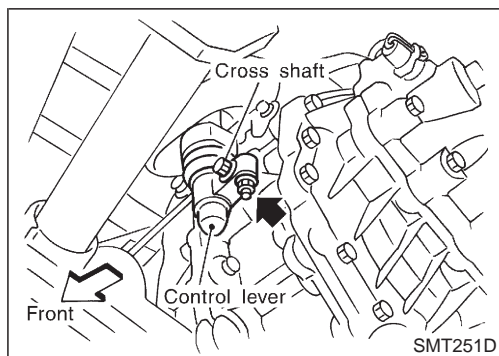

Removal

1. Drain fluid and oil from transfer and transmission (M/T model only).
2. Remove exhaust front and rear tubes. Refer to FE section ("EXHAUST SYSTEM").
3. Remove front and rear propeller shaft. Refer to PD section ("Removal and Installation", "PROPELLER SHAFT").
4. Disconnect neutral position switch and 4WD switch harness connectors.
5. Remove transfer control lever from transfer cross shaft.
6. Remove transfer from transmission.

WARNING:

Support transfer while removing it.

Installation

- Apply recommended sealant to mating surface to transmission. (M/T models only)

Recommended sealant:

Genuine anaerobic liquid gasket, Three Bond TB1215, Loctite Part No. 51813 or equivalent

- Tighten transfer bolts.

Transfer fixing bolts:

⊙: 32 - 42 N·m (3.3 - 4.3 kg-m, 24 - 31 ft-lb)

TRANSFER GEAR CONTROL

SEC. 333

 : N·m (kg-m, in-lb)

 : Fill multi-purpose grease up.

*1 : Securely bend pawls during assembly.
Be careful not to damage boot.

*2 : Do not touch boot with a sharp-pointed
or a hard tool as it breaks easily.

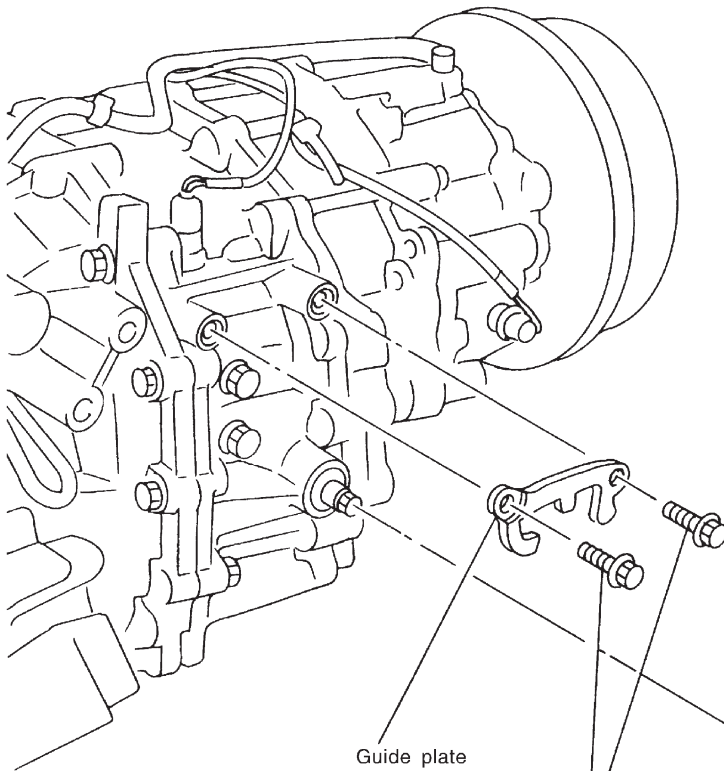

 8 - 11
(0.8 - 1.1, 69 - 95)

 9 - 12
(0.9 - 1.2, 78 - 104)

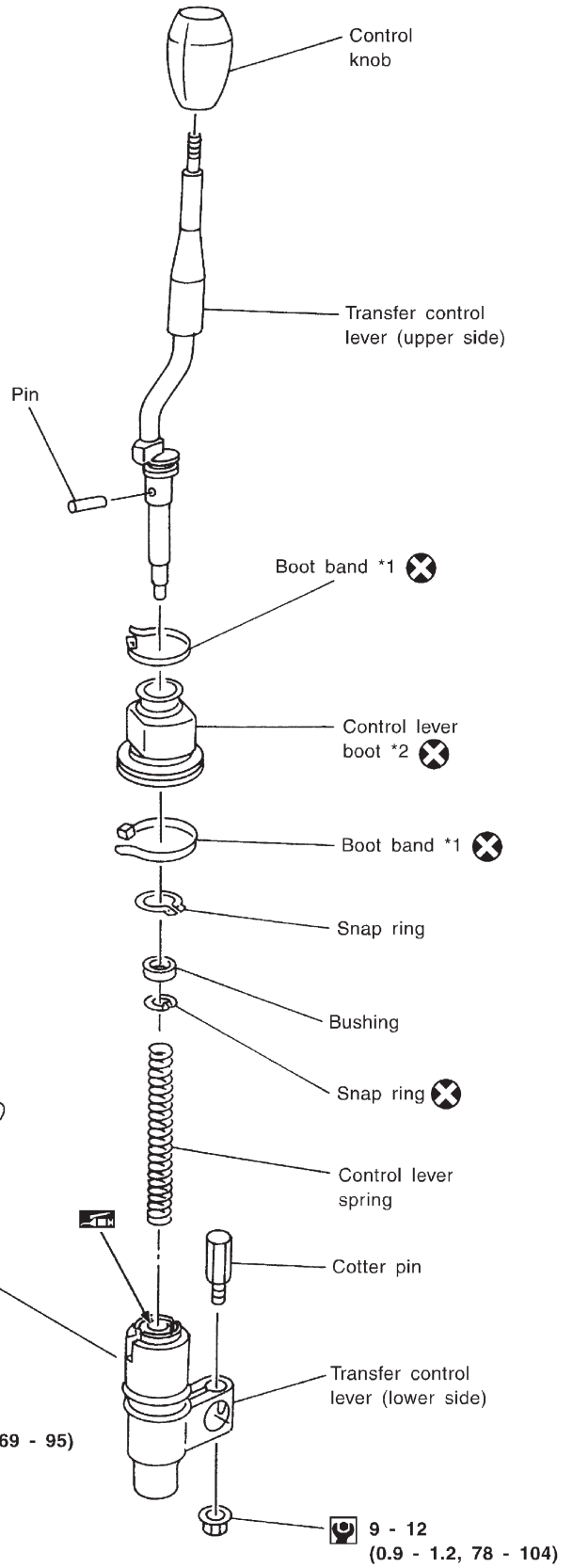

MAJOR OVERHAUL

Case Components

SEC. 331

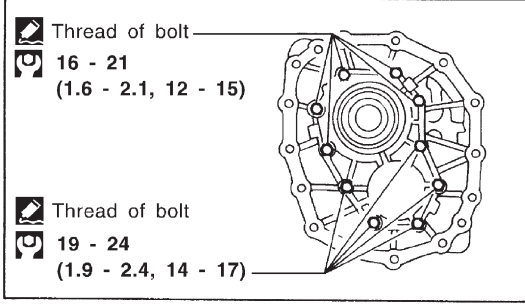
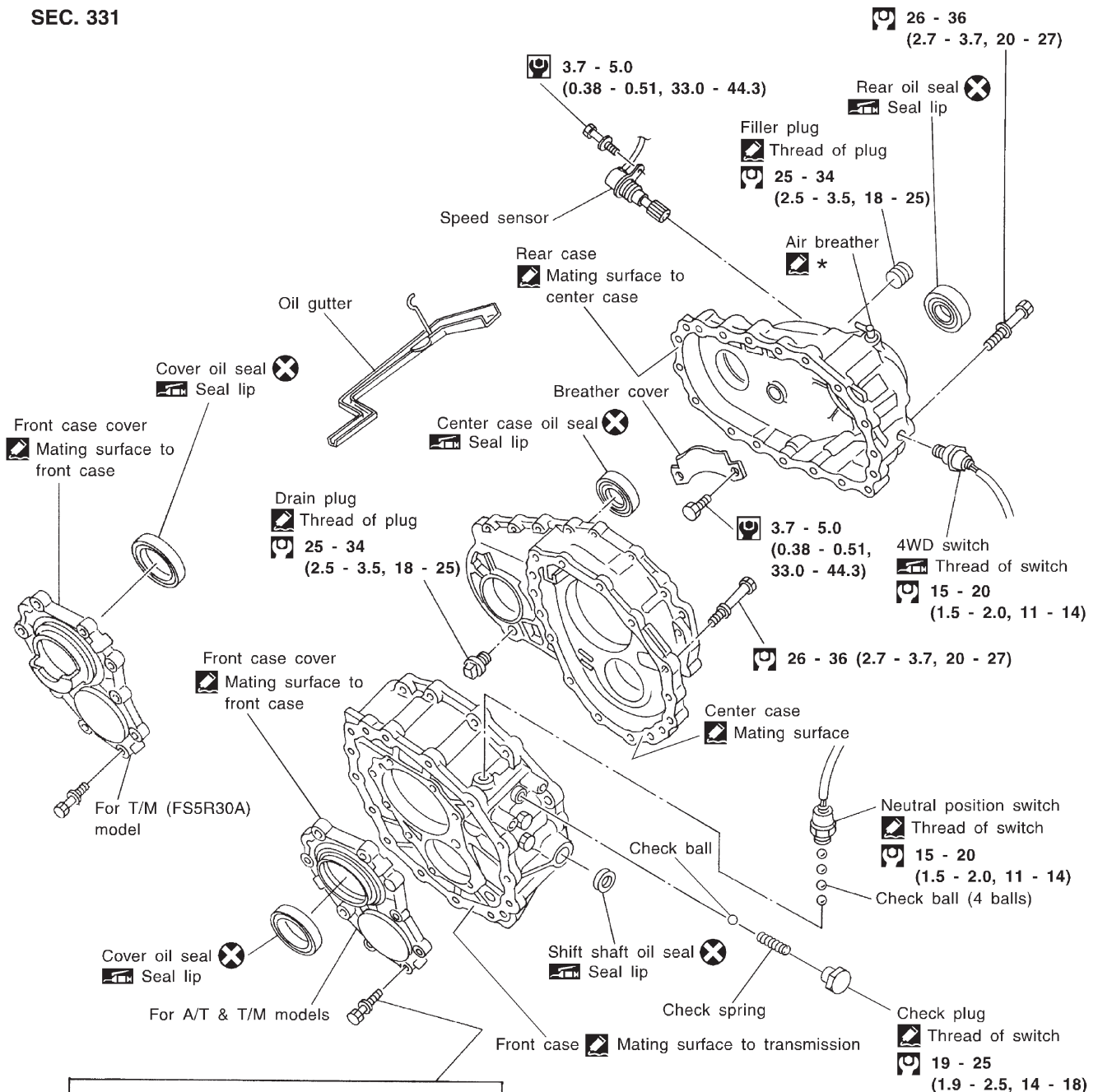

- : N•m (kg-m, in-lb)
- : N•m (kg-m, ft-lb)
- : Apply genuine anaerobic liquid gasket, Three Bond TB1215, Loctite Part No. 51813 or equivalent.
- * : Apply genuine thread locker, Three Bond 1324, Loctite 271 or equivalent.

SMT255D

MAJOR OVERHAUL

Gear Components

SEC. 332

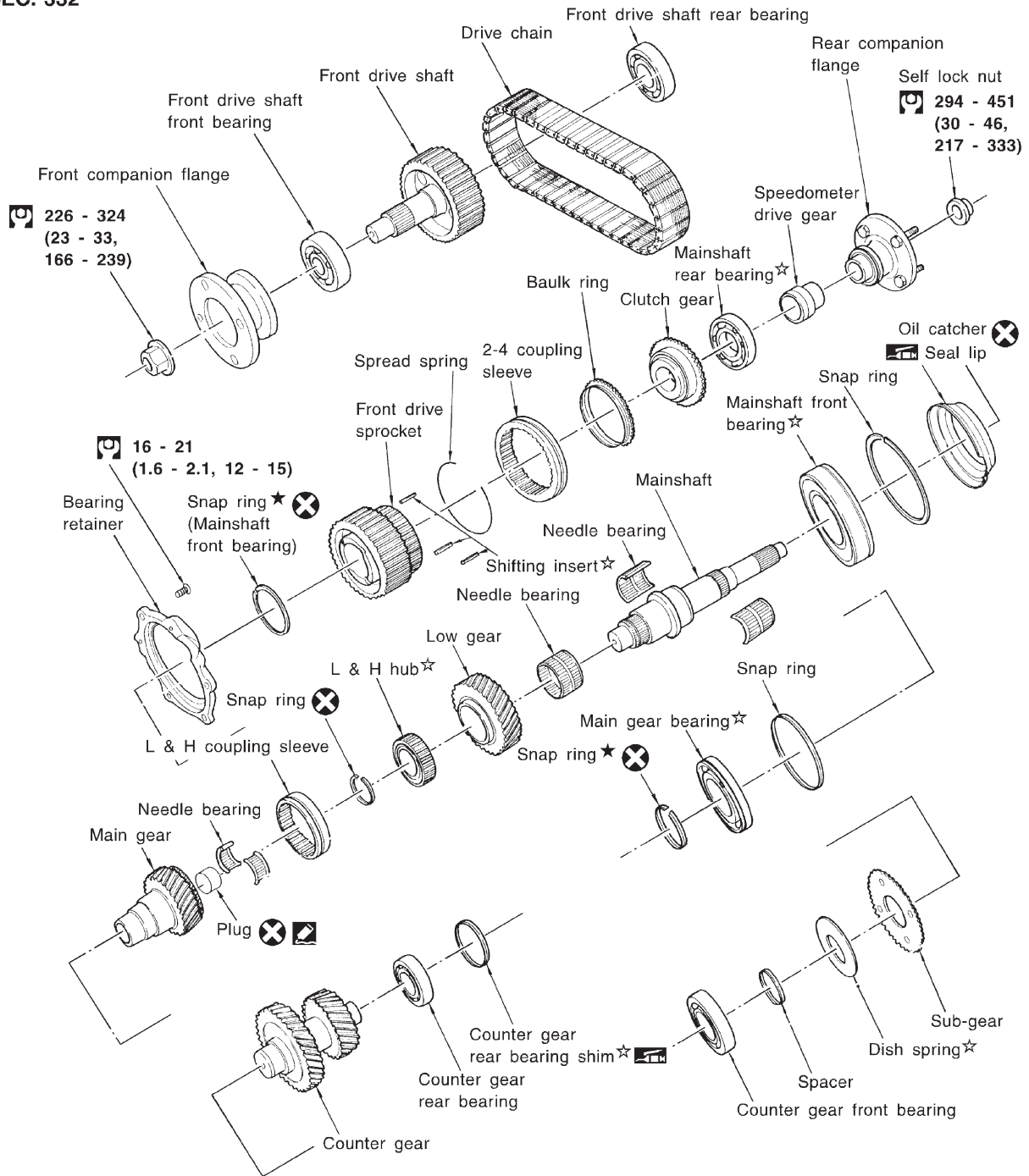

Apply gear oil to gears, shafts, synchronizers and bearings when assembling.

★ : Select with proper thickness.

☆ : Pay attention to its direction.

⊗ : N·m (kg-m, ft-lb)

☒ : Apply genuine anaerobic liquid gasket, Three bond TB1215, Loctite Part No. 51813 or equivalent.

SMT256D

MAJOR OVERHAUL

Shift Control Components

SEC. 333

Neutral position switch

 Thread of switch

 15 - 20 (1.5 - 2.0, 11 - 14)

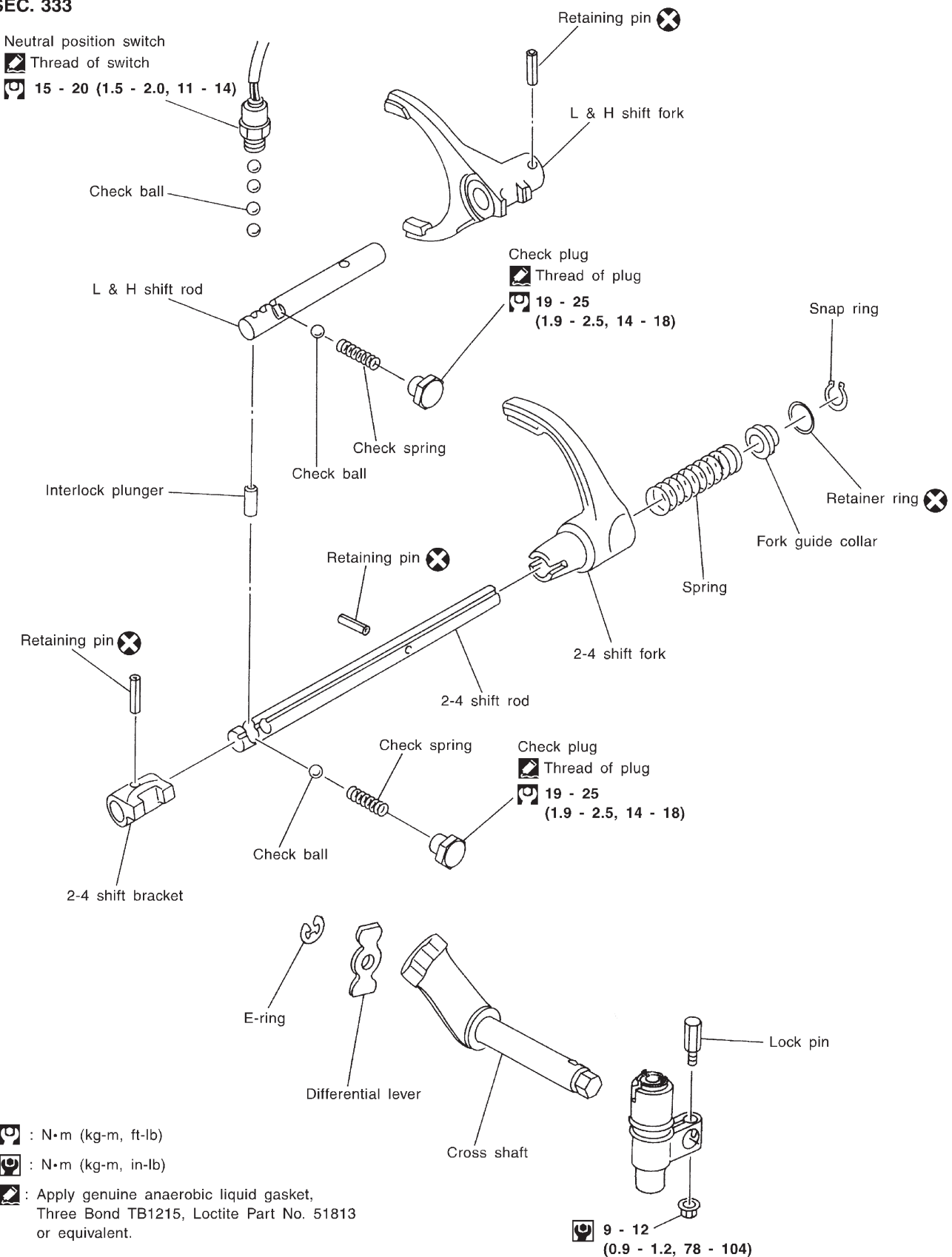

 : N·m (kg-m, ft-lb)

 : N·m (kg-m, in-lb)

 : Apply genuine anaerobic liquid gasket, Three Bond TB1215, Loctite Part No. 51813 or equivalent.

DISASSEMBLY

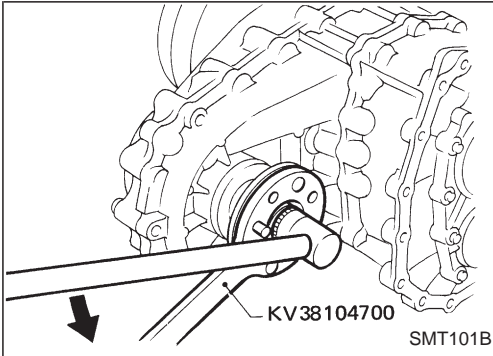

1. Remove nut of front companion flange.

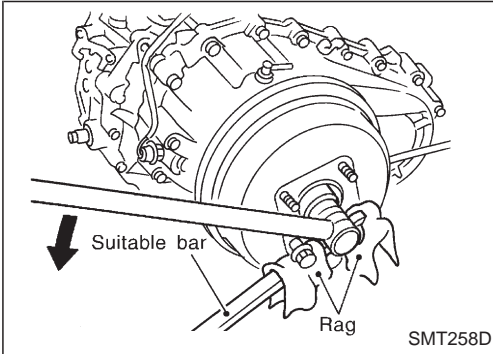

2. Remove center brake components.
 - a. Remove rear companion flange nut.
 - b. Remove brake drum.

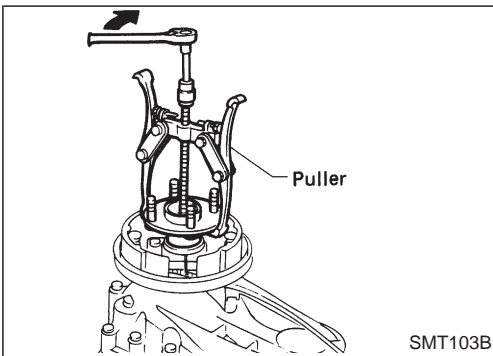

- c. Remove rear companion flange.
- d. Remove center brake components.

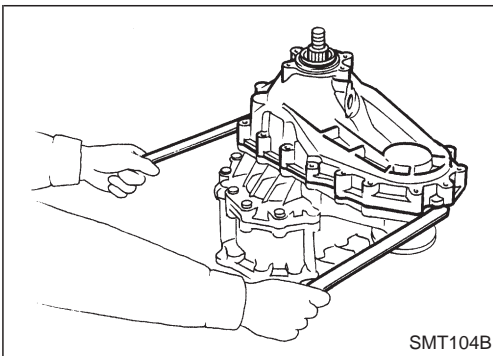

3. Remove rear case.
 - **Be careful not to damage the mating surface.**

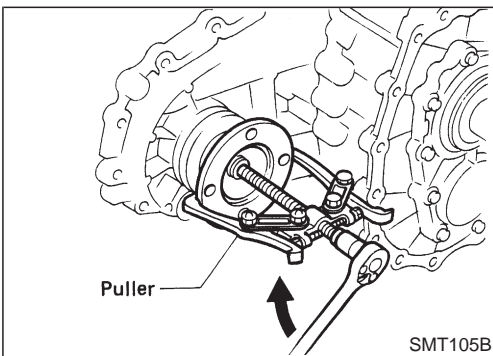

4. Remove front companion flange.

DISASSEMBLY

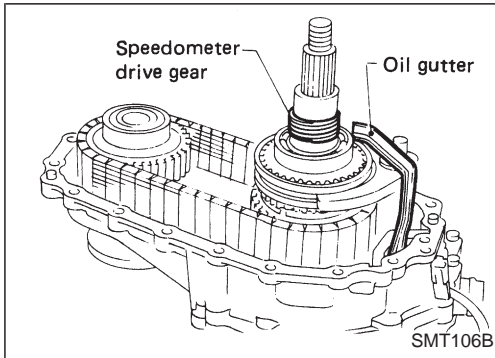

5. Remove speedometer drive gear and oil gutter.

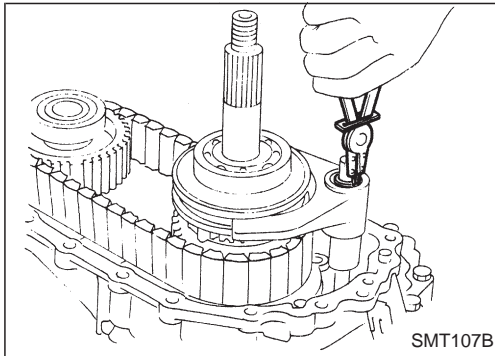

6. Remove snap ring from 2-4 shift rod.

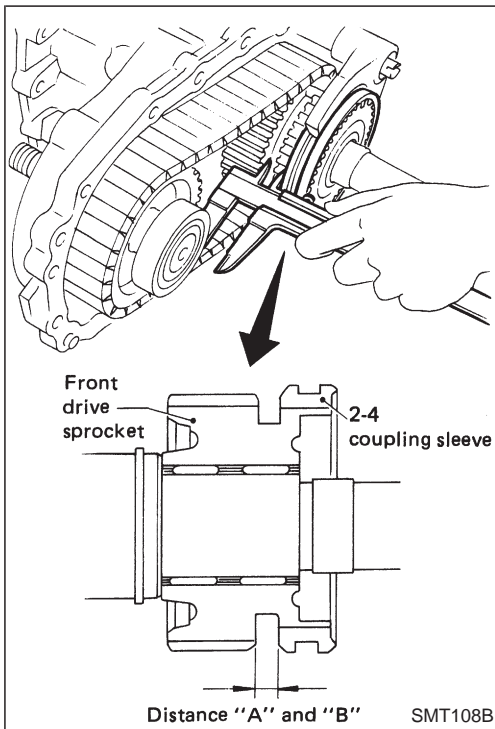

7. Check front drive sprocket end play.
- While holding front drive sprocket forward as far as it will go, measure distance "A" between rear surface of front drive sprocket and front surface of 2-4 coupling sleeve.
 - While holding front drive sprocket back as far as it will go, measure distance "B" as same as step a.
 - Determine front drive sprocket end play to be used by the following equation.

$$\text{Front drive sprocket end play} = A - B$$

Standard:

0.20 - 0.35 mm (0.0079 - 0.0138 in)

- If not within specification, disassemble and check contact surface of gear to hub, washer, bushing, needle bearing and shaft.

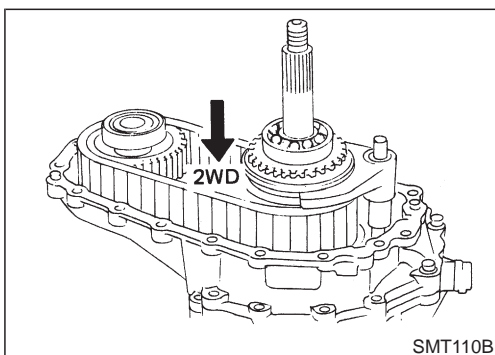

8. Shift 2-4 coupling sleeve to 2WD position.

DISASSEMBLY

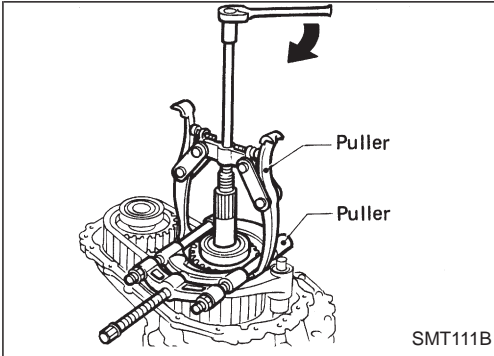

9. Pull out clutch gear and mainshaft rear bearing.

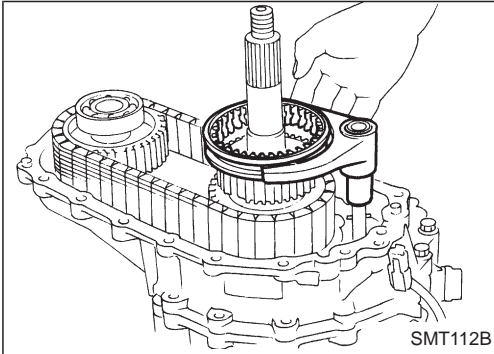

10. Remove 2-4 coupling sleeve with 2-4 shift fork.

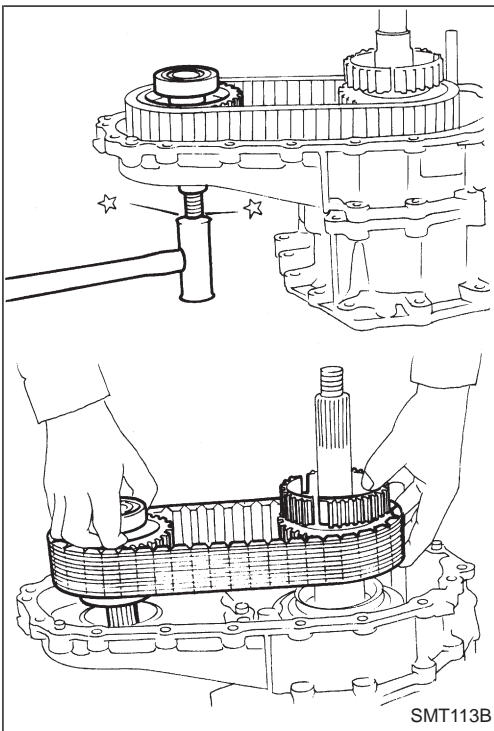

11. Remove front drive shaft assembly, drive chain and front drive sprocket by tapping front end of front drive shaft.

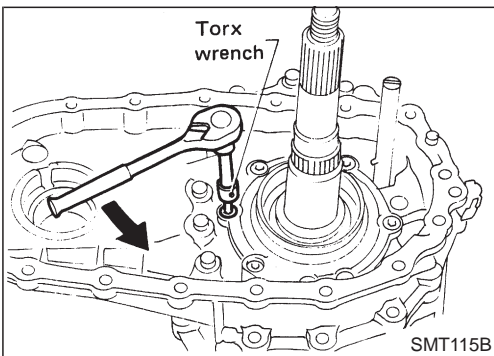

12. Remove bolts securing bearing retainer and then remove bearing retainer.

DISASSEMBLY

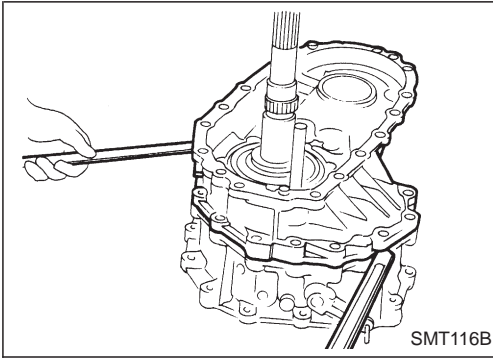

13. Remove bolts securing center case to front case and then separate center case and front case.

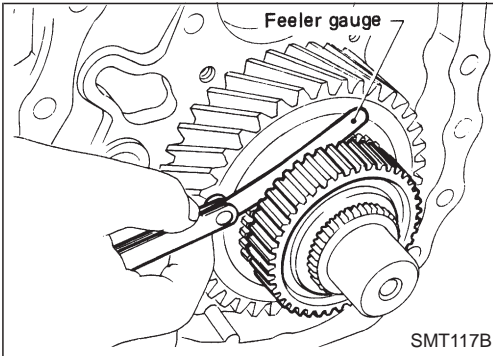

14. Measure end play of low gear.

Standard:

0.20 - 0.35 mm (0.0079 - 0.0138 in)

Refer to SDS, TF-33.

- If end play is beyond the maximum value, check low gear and L & H hub for wear.

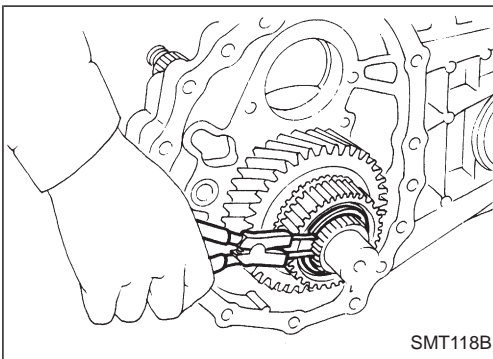

15. Disassemble center case assembly.

- a. Remove snap ring from mainshaft.

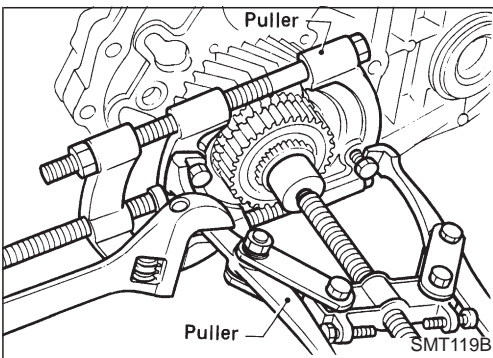

- b. Pull out low gear with L & H hub.

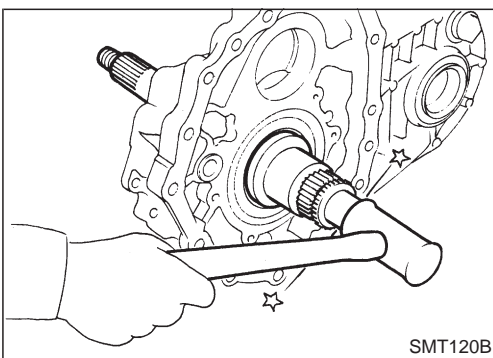

- c. Remove mainshaft by tapping front end of mainshaft.

DISASSEMBLY

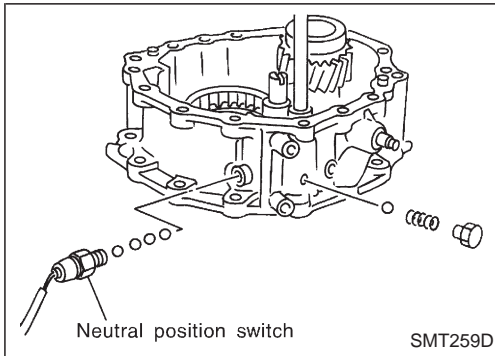

16. Disassemble front case assembly.
- a. Remove the following parts.
- 4WD switch
 - Neutral position switch
 - Check plugs
 - Check springs
 - Check balls
 - **Be careful not to lose the check balls.**

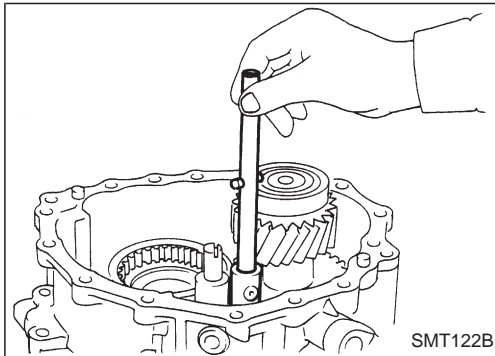

- b. Remove 2-4 shift rod.

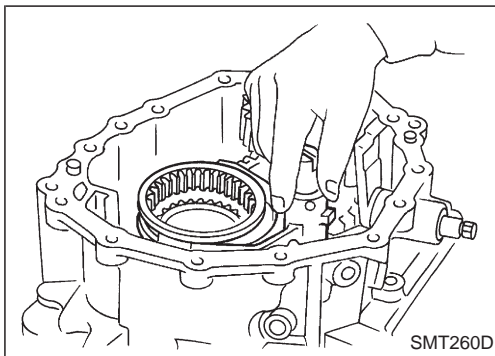

- c. Remove L & H shift rod and fork assembly with coupling sleeve.

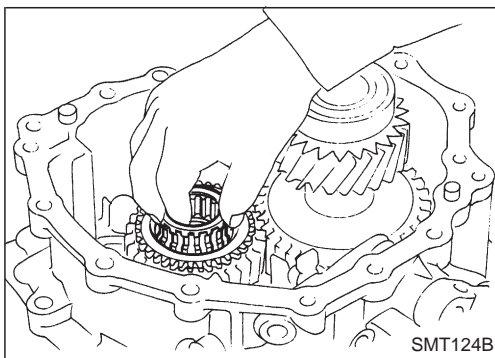

- d. Remove needle bearing from main gear.

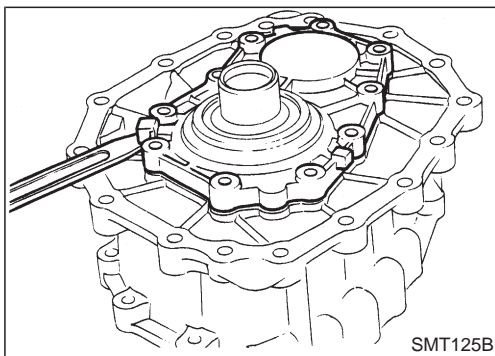

- e. Remove bolts securing front case cover and then remove it.

DISASSEMBLY

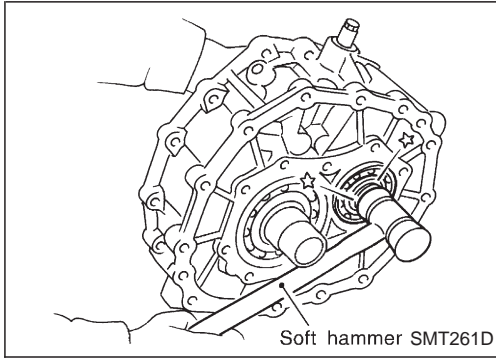

- f. Remove counter gear by tapping it lightly with a soft hammer.

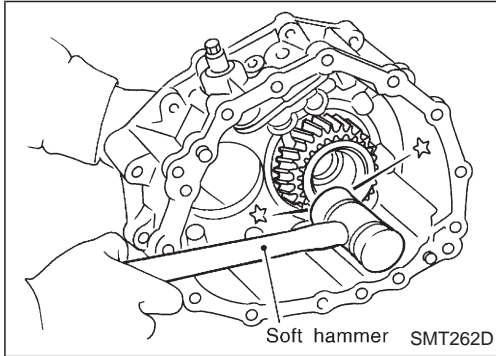

- g. Remove main gear by tapping it lightly with a soft hammer.

REPAIR FOR COMPONENT PARTS

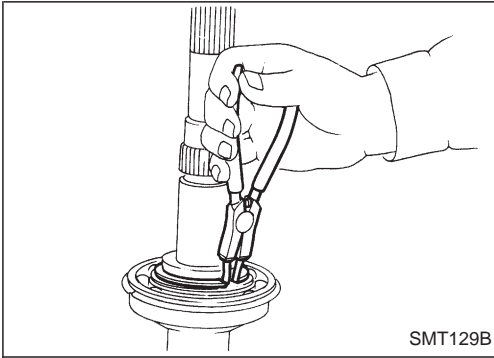

Mainshaft

DISASSEMBLY

1. Remove snap ring and spacer.

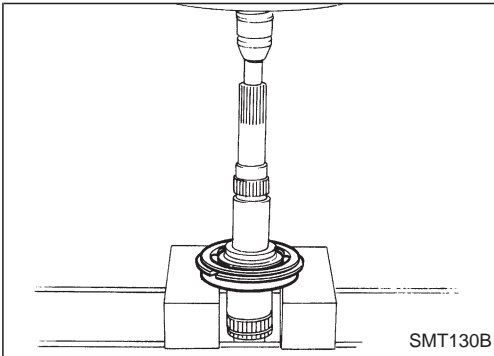

2. Press out mainshaft front bearing from mainshaft.

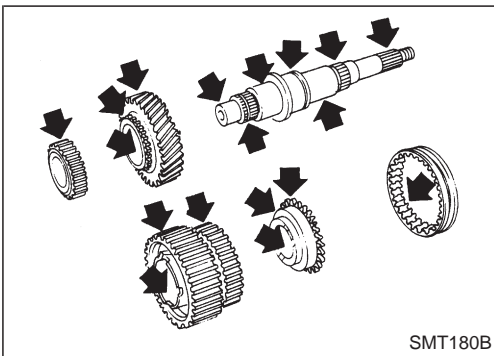

INSPECTION

Gear and shaft

- Check gears for excessive wear, chips or cracks.
- Check shaft for cracks, wear or bending.
- Check coupling sleeve for wear or damage.

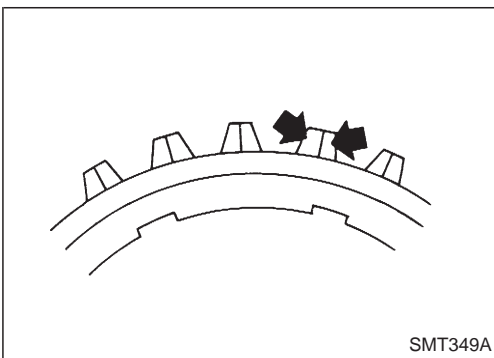

Baulk ring

- Check baulk ring for cracks or deformation.

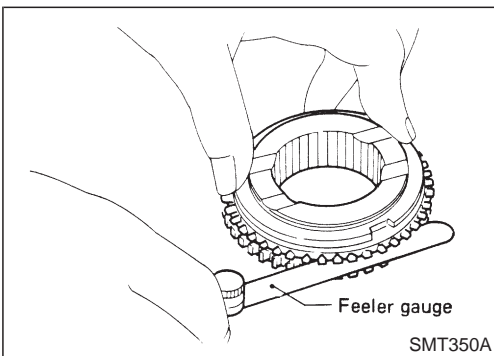

- Measure clearance between baulk ring and gear.

Baulk ring to gear clearance:

Unit: mm (in)

Standard	Wear limit
1.0 - 1.5 (0.039 - 0.059)	0.5 (0.020)

- If not within wear limit, replace baulk ring.

REPAIR FOR COMPONENT PARTS

Mainshaft (Cont'd)

Bearing

- Make sure bearings roll freely and are free from noise, crack, pitting or wear.

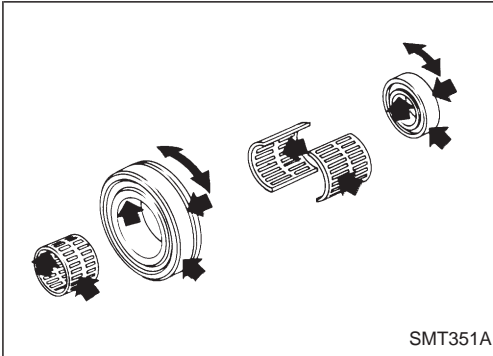

ASSEMBLY

1. Press mainshaft front bearing onto mainshaft.
- Pay special attention to its direction.

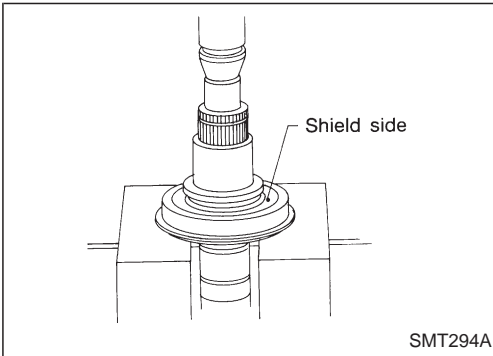

2. Install spacer.
3. Select mainshaft front bearing snap ring with proper thickness and install it.

Allowable clearance between mainshaft front bearing snap ring and groove:

0 - 0.15 mm (0 - 0.0059 in)

Mainshaft front bearing snap ring:
Refer to SDS, TF-33.

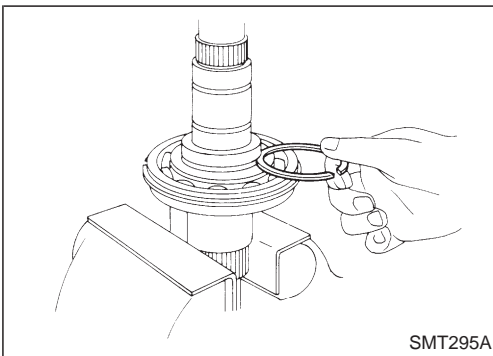

Front Drive Shaft

DISASSEMBLY

- Front drive shaft front bearing

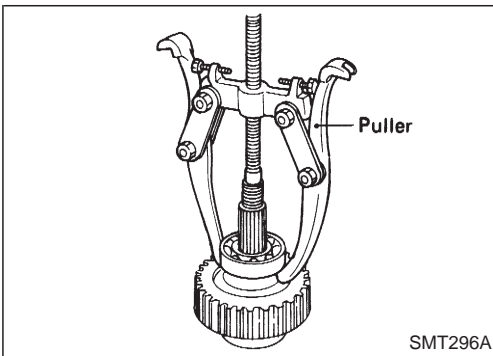

- Front drive shaft rear bearing

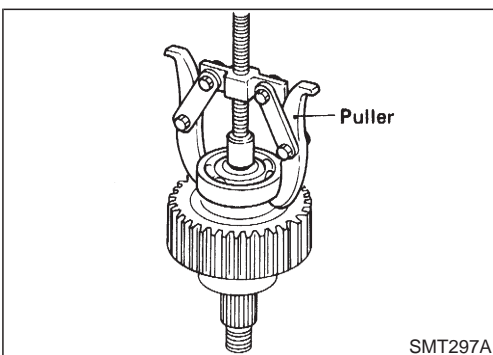

REPAIR FOR COMPONENT PARTS

Front Drive Shaft (Cont'd)

INSPECTION

Sprocket and shaft

- Check sprocket for excessive wear, chips or cracks.
- Check shaft for cracks or wear.

Bearing

- Make sure bearings roll freely and are free from noise, crack, pitting or wear.

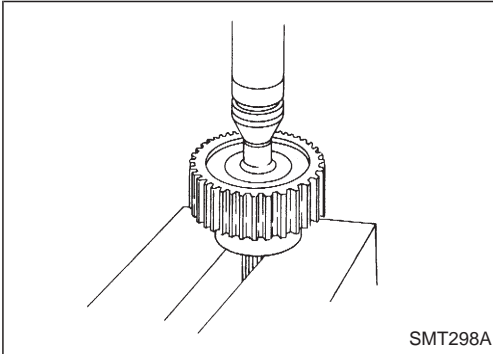
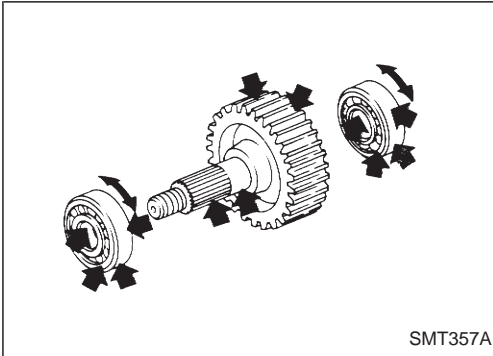

ASSEMBLY

- Press front drive shaft front bearing.

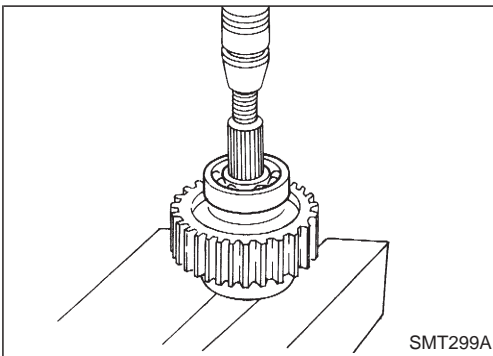

- Press front drive shaft rear bearing.

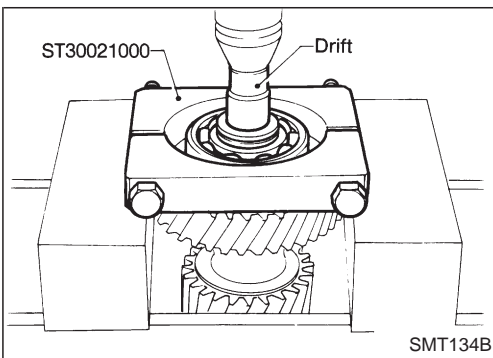

Counter Gear

DISASSEMBLY

1. Press out counter gear front bearing and then remove front sub-gear, spacer and dish spring.
2. Press out counter gear rear bearing and then remove rear sub-gear, spacer and dish spring.

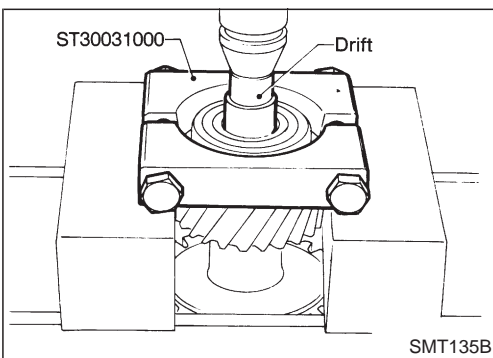

REPAIR FOR COMPONENT PARTS

Counter Gear (Cont'd)

INSPECTION

Gear and shaft

- Check gears for excessive wear, chips or cracks.
- Check shaft for cracks or wear.

Bearing

- Make sure bearings roll freely and are free from noise, crack, pitting or wear.

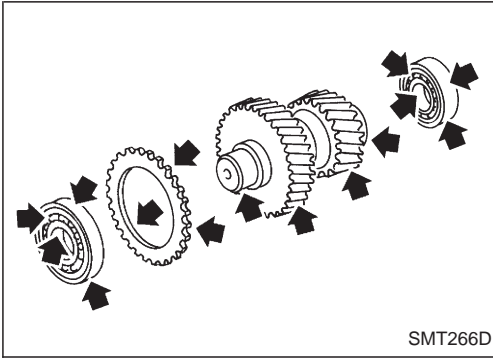

ASSEMBLY

1. Press on counter gear rear bearing.

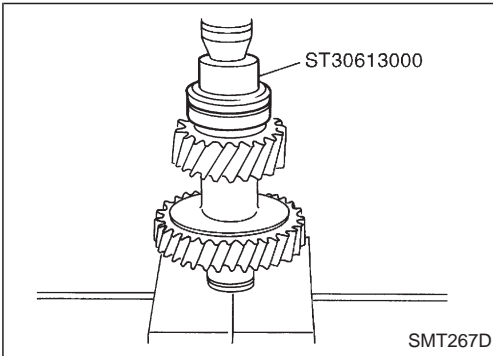

2. Install front sub-gear, dish spring and spacer, and then press on counter gear front bearing.

- Pay attention to direction of dish spring.

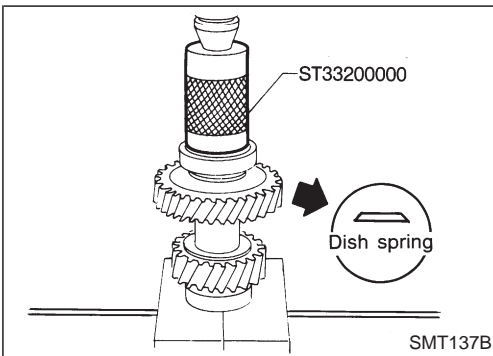

Main Gear

DISASSEMBLY

Main gear bearing

1. Remove snap ring and spacer.

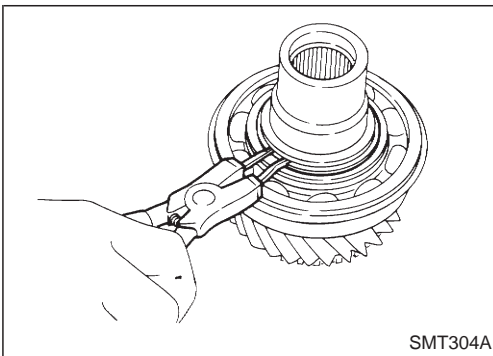

2. Pull out main gear bearing.

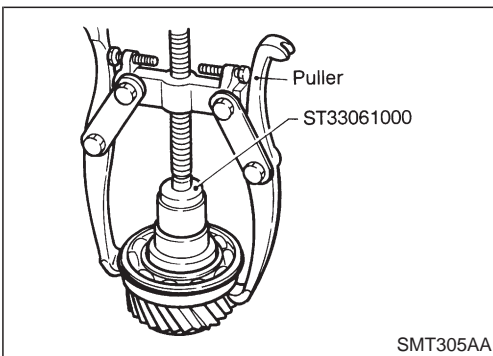

REPAIR FOR COMPONENT PARTS

Main Gear (Cont'd)

Plug

- Always replace it with new one whenever it is removed.

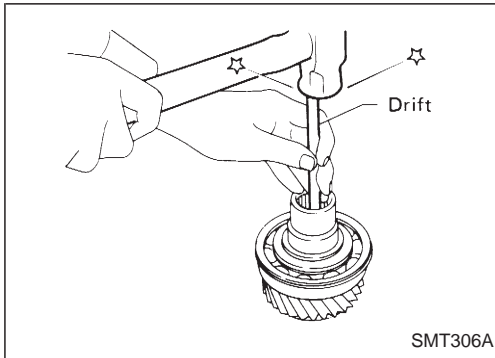

INSPECTION

Gear and shaft

- Check gears for excessive wear, chips or cracks.
- Check shaft for cracks or wear.

Bearing

- Make sure bearings roll freely and are free from noise, crack, pitting or wear.

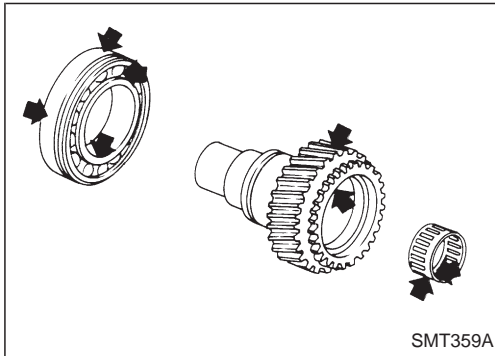

ASSEMBLY

Main gear bearing

1. Press on main gear bearing.
 - Pay attention to its direction.
2. Install spacer.

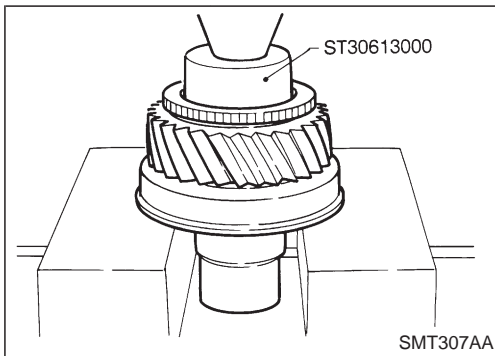

3. Select snap ring with proper thickness and install it.
Allowable clearance between snap ring and groove:
0 - 0.15 mm (0 - 0.0059 in)
Snap ring (main gear bearing):
Refer to SDS, TF-33.

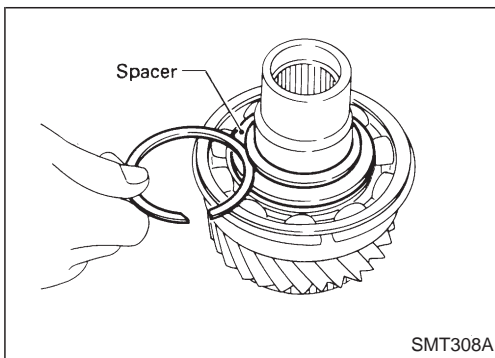

Plug

- Apply sealant to plug and install it.

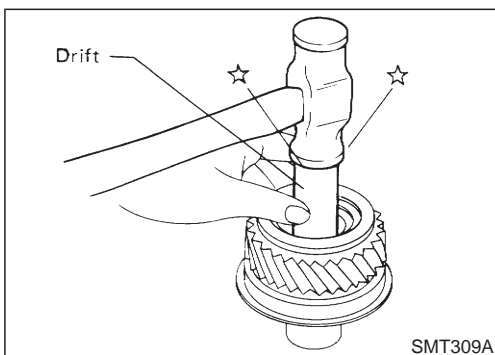

REPAIR FOR COMPONENT PARTS

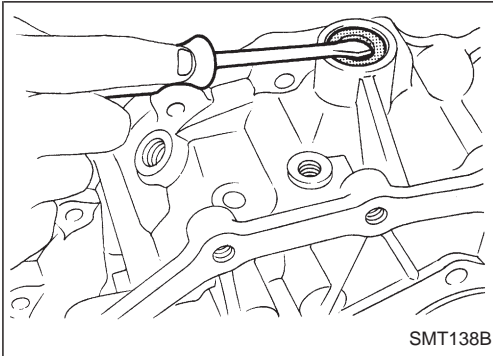

Front Case

SHIFT SHAFT OIL SEAL

Removal

- Use a screwdriver to pry out old seal.
- Be careful not to damage case.
- Always replace with a new one whenever it has been removed.

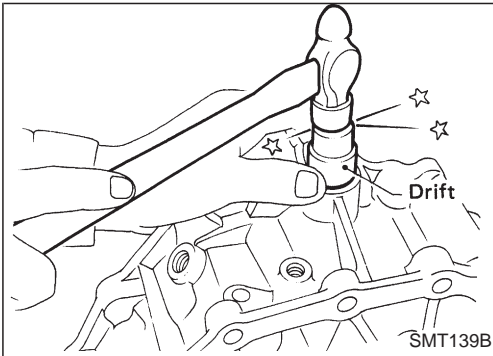

Installation

- Install new shift shaft oil seal until flush with case.
- Before installing, apply multi-purpose grease to seal lip.

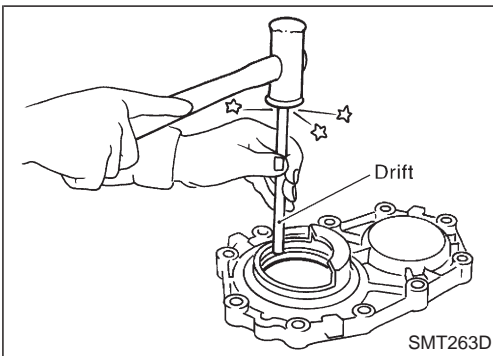

Front Case Cover

Removal

- Take out old seal from inside of front case cover.
- Be careful not to damage front case cover.

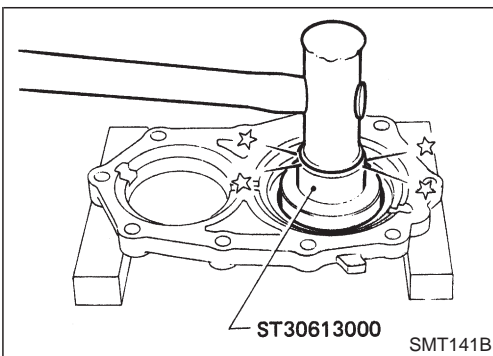

Installation

- Install new front case cover oil seal until it stops.
- Before installing, apply multi-purpose grease to seal lip.

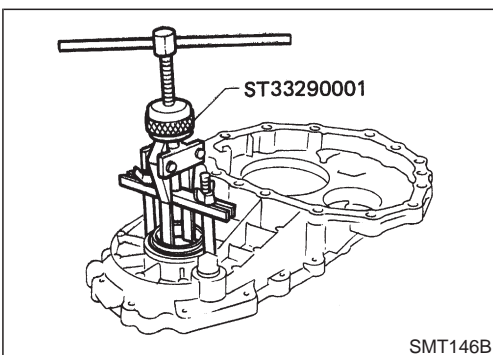

Center Case

CENTER CASE OIL SEAL

Removal

- Remove center case oil seal.

REPAIR FOR COMPONENT PARTS

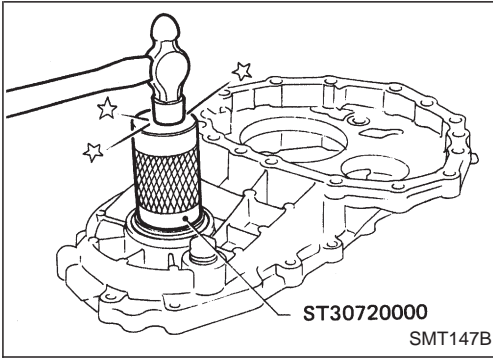

Installation

- Install center case oil seal.

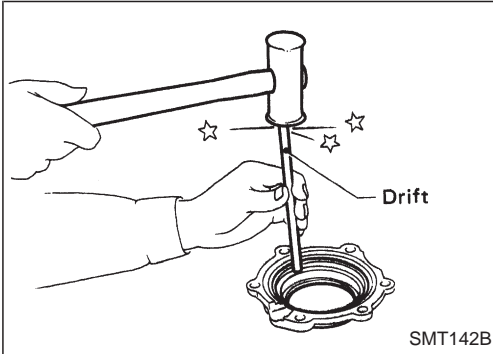

Bearing Retainer

OIL CATCHER

Removal

- Drive out oil catcher from inside of bearing retainer.
- Be careful not to damage bearing retainer.

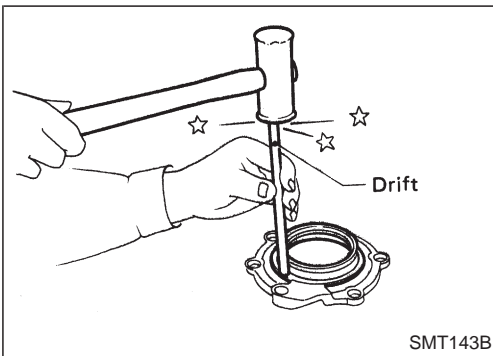

Installation

- Install oil catcher until it stops.
- Be careful not to damage or distort oil catcher or bearing retainer.
- Before installing, apply multi-purpose grease to seal lip.

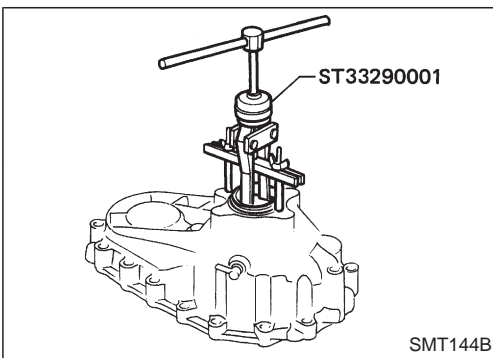

Rear Case

REAR OIL SEAL

Removal

- Pull out rear oil seal.

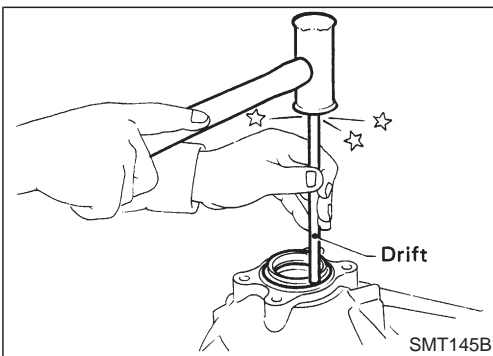

Installation

- Install new rear oil seal until it stops.
- Before installing, apply multi-purpose grease to seal lip.

REPAIR FOR COMPONENT PARTS

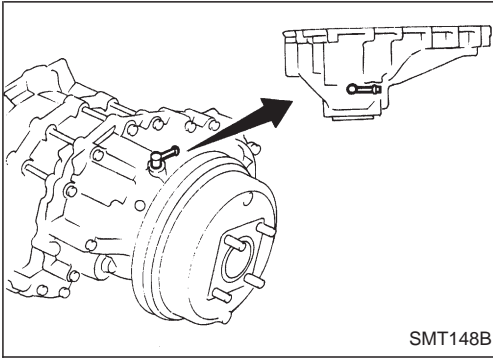

SMT148B

AIR BREATHER

- Install as shown in illustration.
Thread locker:
Refer to TF-10.

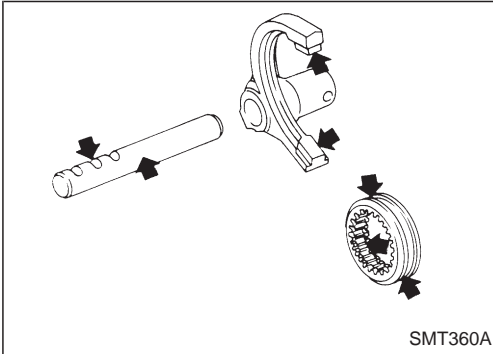

SMT360A

Shift Control Components

INSPECTION

- Check contact surface and sliding surface for wear, scratches, projections or other faulty conditions.

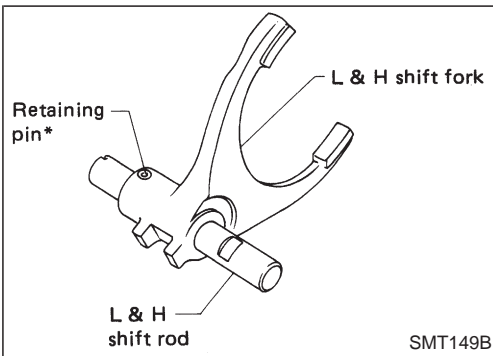

SMT149B

L & H SHIFT ROD & FORK

- Assemble as shown in illustration.
* This pin is the same size as the one for 2-4 shift rod.

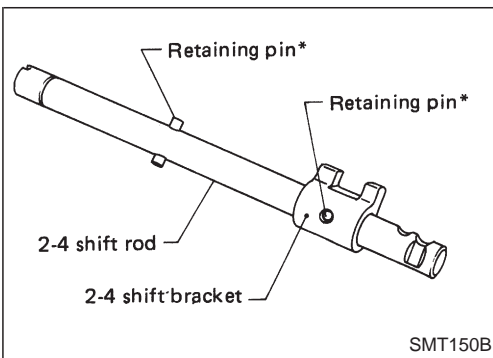

SMT150B

2-4 SHIFT ROD & FORK

- Assemble as shown in illustration.
* These pins are the same size.

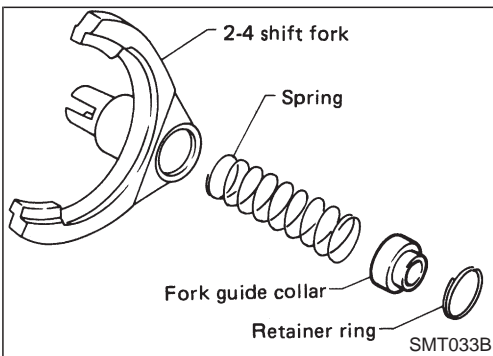

SMT033B

- Pay attention to the direction of fork guide collar.

ASSEMBLY

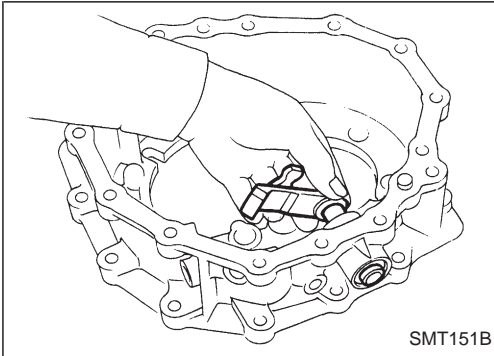

1. Install cross shaft.

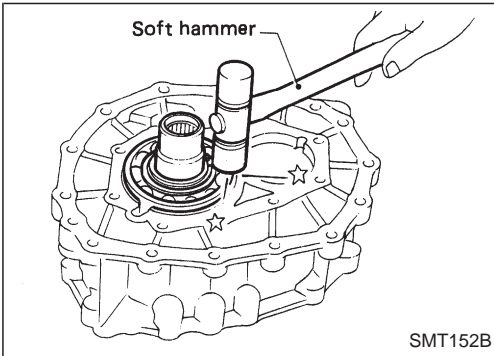

2. Assemble front case.
 - a. Install main gear assembly by tapping it lightly with a soft hammer.

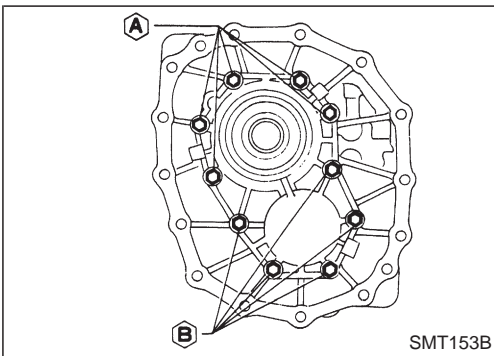

- b. Apply sealant to the mating surface and bolts of front case cover and install it on front case.

- **Apply recommended sealant to these ten bolts.**

- **Tightening torque**

A:

: 16 - 21 N·m (1.6 - 2.1 kg-m, 12 - 15 ft-lb)

B:

: 19 - 24 N·m (1.9 - 2.4 kg-m, 14 - 17 ft-lb)

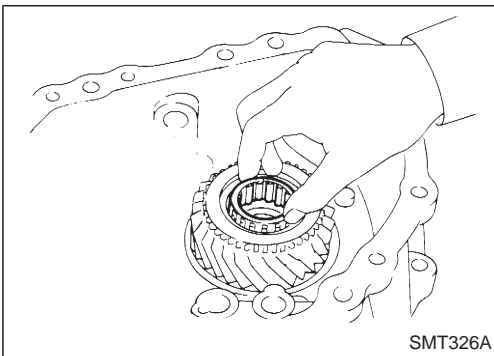

- c. Apply gear oil to needle bearing and install it into main gear.

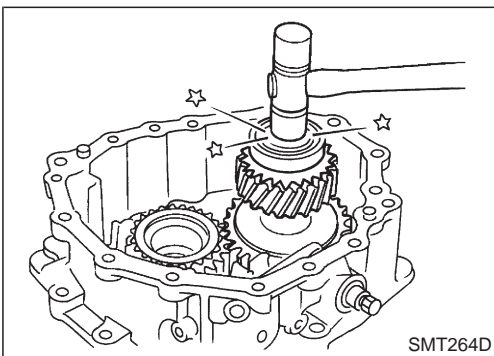

- d. Install counter gear assembly by tapping it lightly with a soft hammer.

ASSEMBLY

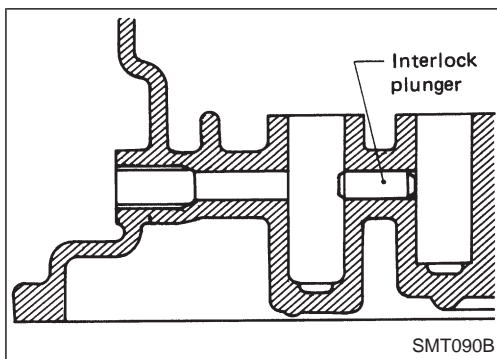

e. Insert interlock plunger into front case.

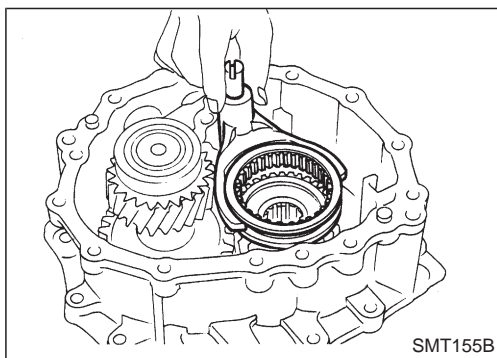

f. Install L & H shift rod and fork assembly with coupling sleeve.

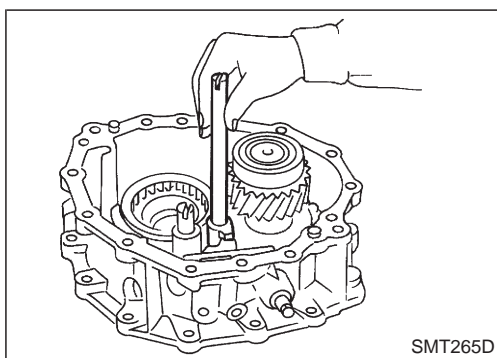

g. Install 2-4 shift rod.

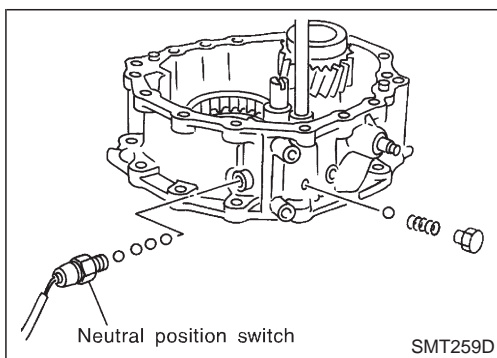

h. Install switches, check balls, check springs and plugs.
 ● **Apply sealant to switches and plugs.**

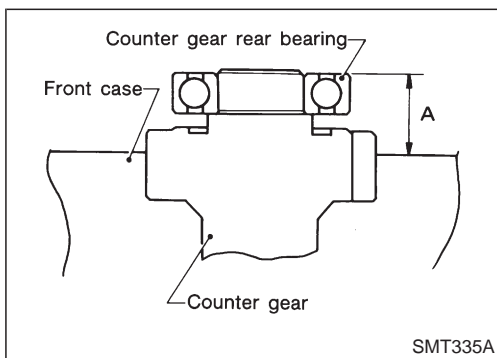

3. Select counter gear rear bearing shim.

Counter gear end play:
0 - 0.2 mm (0 - 0.008 in)

a. Measure distance "A" between upper surface of counter gear rear bearing and mating surface of front case.

ASSEMBLY

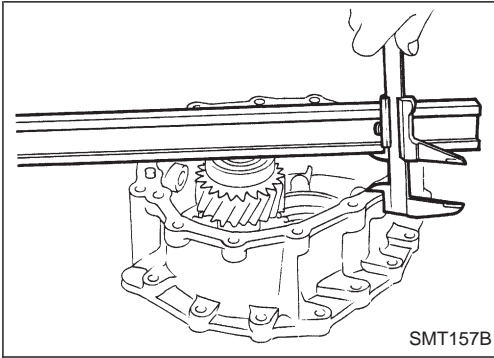

- b. Select suitable shim using SDS table as a guide.
Counter gear rear bearing shim:
Refer to SDS, TF-33.

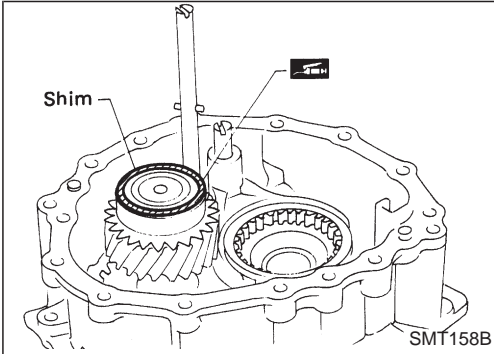

4. Place suitable shim on counter gear rear bearing with grease.
5. Apply gear oil to each part in front case.

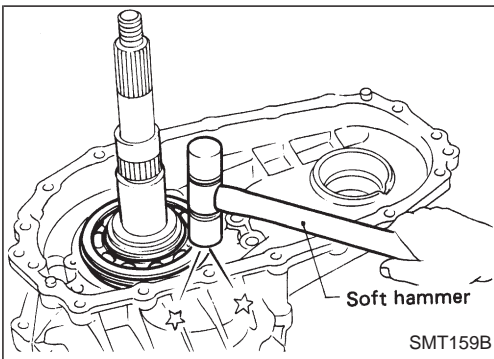

6. Install mainshaft on center case.
a. Install mainshaft on center case by tapping it lightly.
● **Apply gear oil to mainshaft front bearing.**

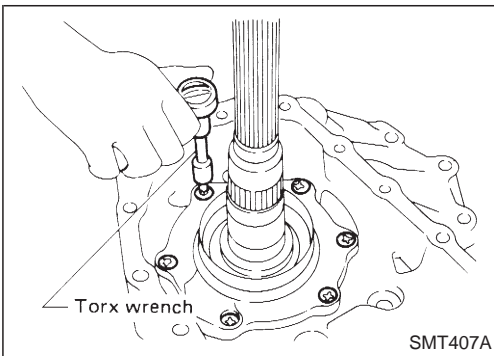

- b. Install bearing retainer.

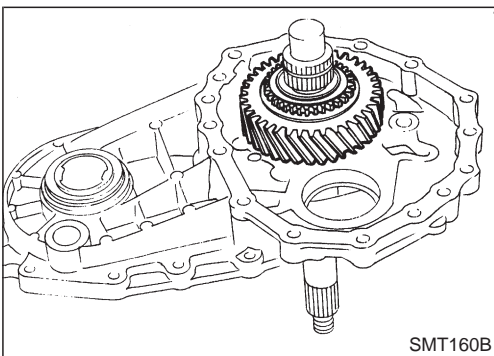

- c. Install low gear and its bearing to mainshaft.
● **Apply gear oil to needle bearing.**

ASSEMBLY

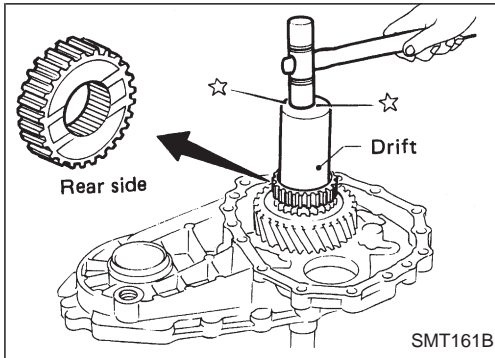

- d. Install L & H hub and snap ring to mainshaft.
- Pay attention to direction of L & H hub.

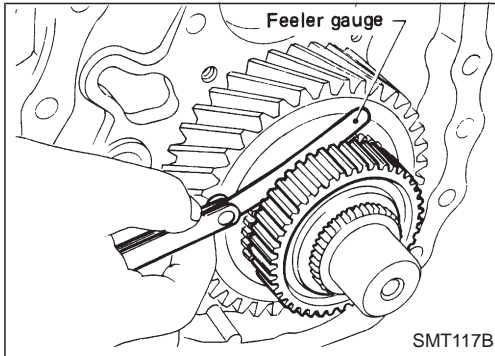

- e. Measure end play of low gear.
- Standard:**
0.20 - 0.35 mm (0.0079 - 0.0138 in)

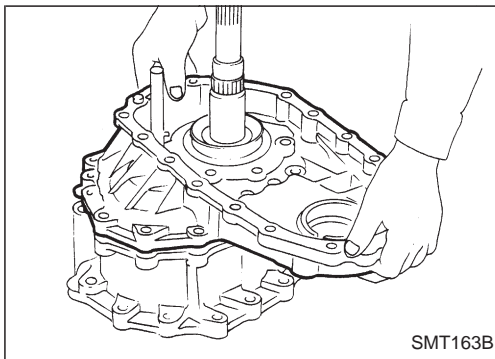

7. Apply sealant to mating surface and put center case assembly onto front case and tighten bolts.

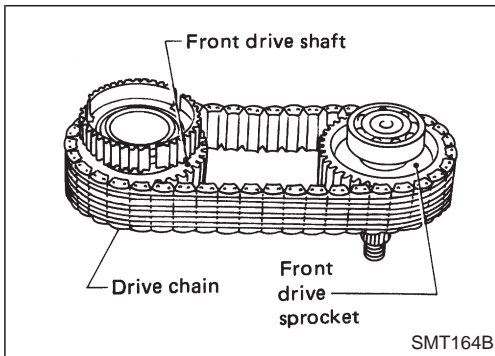

8. Assemble center case assembly.
- a. Put drive chain onto front drive sprocket and front drive shaft, and then put them in center case.

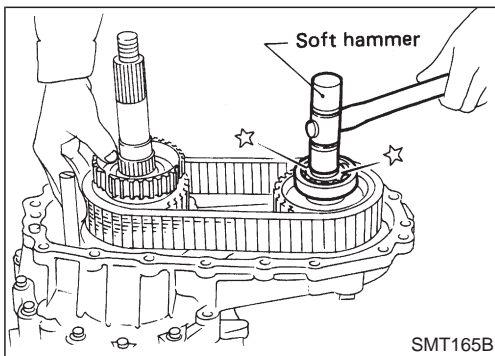

- b. Install front drive shaft by tapping it lightly with a soft hammer.
- Make sure shafts are lined up in case.

ASSEMBLY

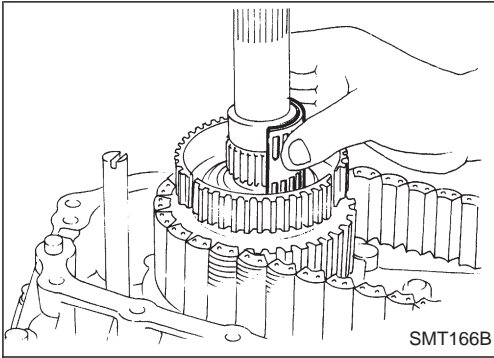

- c. Apply gear oil to needle bearings and install them into front drive sprocket.
- **These needle bearings can be easily installed if front drive sprocket is rotated during their installation.**

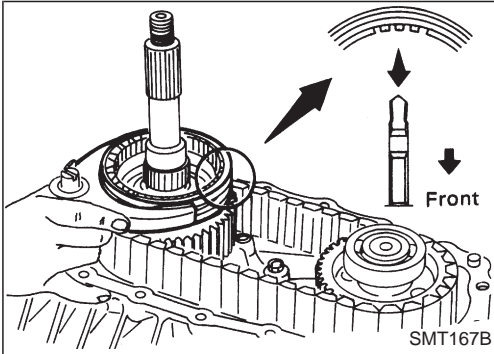

- d. Install 2-4 coupling sleeve with 2-4 shift fork.
- **Pay attention to direction of coupling sleeve.**

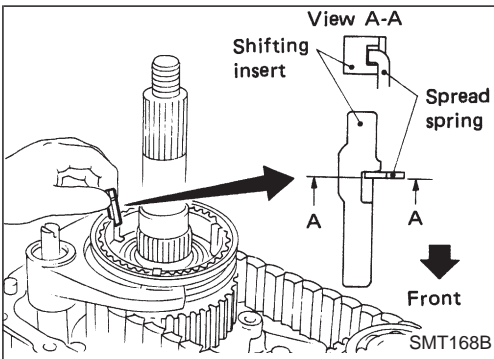

- e. Install shifting inserts and spread spring.
- **Pay attention to direction of shifting inserts.**

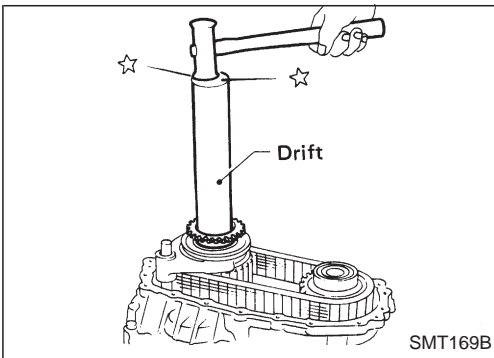

- f. Install baulk ring and then install clutch gear.

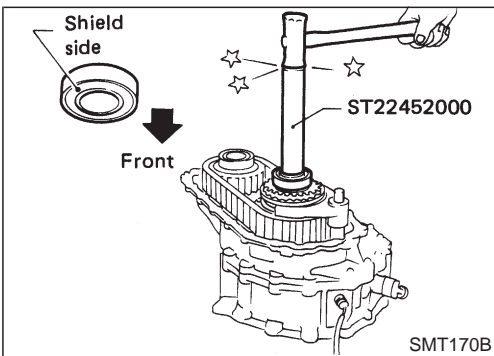

- g. Install mainshaft rear bearing.
- **Pay attention to its direction.**

ASSEMBLY

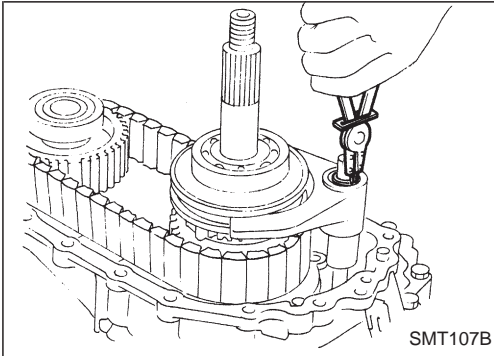

h. Install snap ring to 2-4 shift rod.

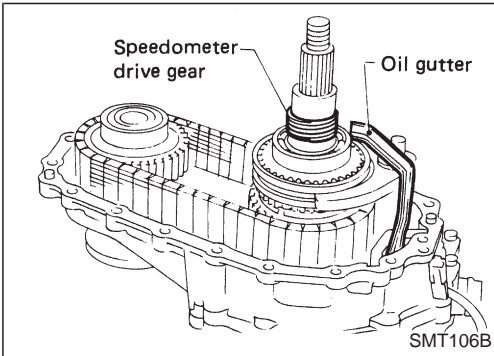

- i. Install speedometer drive gear and oil gutter.
- j. Apply gear oil to each part in center case.

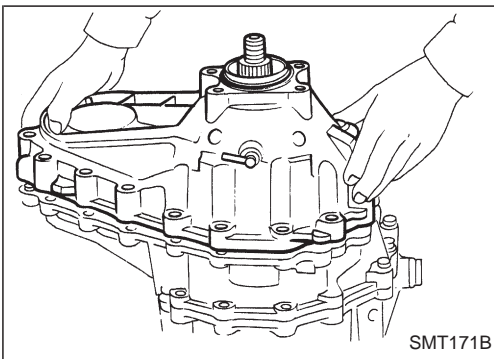

- 9. Apply sealant to mating surface. Set center case assembly onto front case, then tighten bolts.
- 10. Install front and rear companion flanges and center brake components.

SERVICE DATA AND SPECIFICATIONS (SDS)

General Specifications

Transfer model		TX12A	
Gear ratio	High	1.000	
	Low	2.020	
Number of teeth	Main gear	29	
	Low gear	37	
	Counter gear	High	38
		Low	24
	Front drive sprocket	41	
Front drive shaft	41		
Fluid capacity	liters (Imp qt)	1.9 (1-5/8)	

Inspection and Adjustment

GEAR END PLAY

Unit: mm (in)

Front drive sprocket	0.20 - 0.35 (0.0079 - 0.0138)
Low gear	0.20 - 0.35 (0.0079 - 0.0138)
Counter gear	0 - 0.2 (0 - 0.008)

CLEARANCE BETWEEN BAULK RING AND CLUTCH GEAR

Unit: mm (in)

Standard	Wear limit
1.0 - 1.5 (0.039 - 0.059)	0.5 (0.020)

AVAILABLE SNAP RING

Mainshaft front bearing

Unit: mm (in)

Allowable clearance	0 - 0.15 (0 - 0.0059)
Thickness	Part number
3.0 (0.118)	33138-73P10
3.1 (0.122)	33138-73P11
3.2 (0.126)	33138-73P12

Main gear bearing

Unit: mm (in)

Allowable clearance	0 - 0.15 (0 - 0.0059)
Thickness	Part number
2.6 (0.102)	33114-73P00
2.7 (0.106)	33114-73P01
2.8 (0.110)	33114-73P02

AVAILABLE SHIM

Counter gear rear bearing

Distance "A" mm (in)	Shim(s)	
	Thickness mm (in)	Part number
40.6 - 40.5 (1.598 - 1.594)	Not necessary	
40.5 - 40.4 (1.594 - 1.591)	0.1 (0.004)	33112-C6900
40.4 - 40.3 (1.591 - 1.587)	0.2 (0.008)	33112-C6901
40.3 - 40.2 (1.587 - 1.583)	0.3 (0.012)	33112-C6902
40.2 - 40.1 (1.583 - 1.579)	0.4 (0.016)	33112-C6903
40.1 - 40.0 (1.579 - 1.575)	0.5 (0.020)	33112-33G00
40.0 - 39.9 (1.575 - 1.571)	0.6 (0.024)	33112-33G01

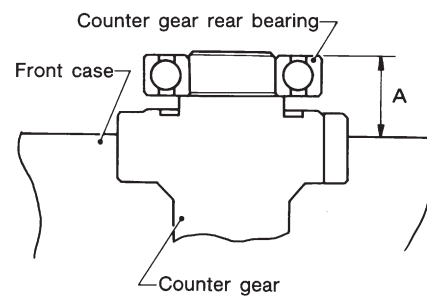

SMT335A