

NISSAN PATROL

Y61-A

UTSC2-E7G0K



Printing: September 2008 (57)  
Publication No.: OM7E-0Y61G0  
Printed in Japan

Y61-A



# PATROL

OWNER'S MANUAL

# Foreword

Welcome to the growing family of new NISSAN owners. This vehicle has been delivered to you with confidence. It has been produced using the latest techniques and strict quality control.

This manual was prepared to help you understand the operation and maintenance of your vehicle so that you may enjoy many kilometers (miles) of driving pleasure. Please read through this manual before operating your vehicle.

A separate warranty information booklet explains details about the warranties covering your vehicle.

Your NISSAN dealer knows your vehicle best. When you require any service or have any questions, we will be glad to assist you with the extensive resources available for you.

## IMPORTANT SAFETY INFORMATION

### REMINDERS FOR SAFETY!

Follow these important driving rules to help ensure a safe and complete trip for you and your passengers!

- **NEVER drive under the influence of alcohol or drugs.**
- **ALWAYS observe posted speed limits and never drive too fast for conditions.**
- **ALWAYS use your seat belts and appropriate child restraint systems.**
- **ALWAYS provide information about the proper use of vehicle safety features to all occupants of the vehicle.**
- **ALWAYS review this Owner's Manual for important safety information.**

### WHEN READING THE MANUAL

This manual includes information for all options available on this model. Therefore, you may find some information that does not apply to your vehicle.

All information, specifications and illustrations in this manual are those in effect at the time of printing. NISSAN reserves the right to change specifications or design without notice and without obligation.

### MODIFICATION OF YOUR VEHICLE

This vehicle should not be modified. Modification could affect its performance, safety or durability, and may even violate governmental regulations. In addition, damage or performance problems resulting from modification may not be covered under NISSAN warranties.

### READ FIRST — THEN DRIVE SAFELY

Before driving your vehicle, read this Owner's Manual carefully. This will ensure familiarity with controls and maintenance requirements, assisting you in the safe operation of your vehicle.

Throughout this manual we have used the symbol  followed by the word **WARNING**. This is used to indicate the presence of a hazard which may cause the possibility of a personal injury or other damage and must be followed precisely.

The word **CAUTION** is also used throughout the manual to indicate the presence of a hazard that could cause minor or moderate personal injury or damages to your vehicle. To avoid or reduce the risk, the procedures must be followed carefully.

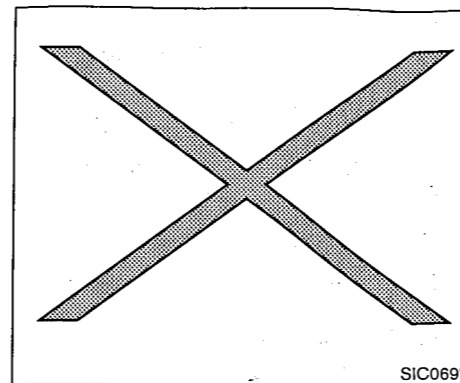

**Failure to operate 4WD models correctly may result in loss of control or an accident. Be sure to read "DRIVING FOUR-WHEEL DRIVE (4WD) SAFELY" in the "5. Starting and driving" section.**

If you see this symbol, it means **"Do not do this"** or **"Do not let this happen"**.



If you see a symbol similar to these in an illustration, it means the arrow points to the front of the vehicle.



Arrows in an illustration that are similar to these indicate movement or action.



Arrows in an illustration that are similar to these call attention to an item in the illustration.

For descriptions specified for four-wheel drive (4WD) models, a  mark is placed at the beginning of the applicable sections/items.

# Contents

<b>Safety — seats, seat belts and supplemental restraint system</b>	<b>1</b>
<b>Instruments and controls</b>	<b>2</b>
<b>Pre-driving checks and adjustments</b>	<b>3</b>
<b>Display screen, heater and air conditioner, and audio system</b>	<b>4</b>
<b>Starting and driving</b>	<b>5</b>
<b>In case of emergency</b>	<b>6</b>
<b>Appearance and care</b>	<b>7</b>
<b>Maintenance and do-it-yourself</b>	<b>8</b>
<b>Technical information</b>	<b>9</b>
<b>Index</b>	<b>10</b>

# 1 Safety — seats, seat belts and supplemental restraint system

Seats .....		Seat belt maintenance..... 1-2.....	1-21
Front seats .....	1-3	Child restraints.....	1-21
Rear seats .....	1-6	Precautions on child restraints usage.....	1-21
3rd seats .....	1-8	Universal child restraints for front passenger	
Head restraints.....	1-10	seat and rear seats (for Europe).....	1-23
Armrest .....	1-10	Installation of child restraint system.....	1-26
Seat belts .....	1-11	Child restraint anchorage (Wagon model for	
Precautions on seat belt usage.....	1-11	Australia) .....	1-37
Child safety .....	1-13	Supplemental restraint system .....	1-38
Pregnant women.....	1-14	Front and side air bag system .....	1-38
Injured persons.....	1-15	Driver air bag system .....	1-44
Center mark on seat belts .....	1-15	Air bag warning labels .....	1-47
Three-point type seat belts.....	1-15	Air bag warning light .....	1-47
Two-point type seat belts .....	1-20		

## SEATS

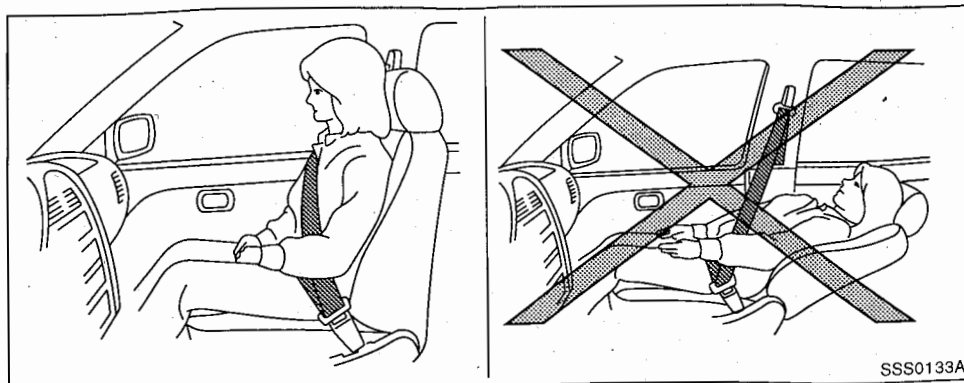

### **⚠ WARNING:**

- Do not drive and/or ride in the vehicle with the seatback reclined. This can be dangerous. The shoulder belt will not be properly against the body. In an accident, you and your passengers could be thrown into the shoulder belt and receive neck or other serious injuries. You and your passengers could also slide under the lap belt and receive serious injuries.

- For the most effective protection while the vehicle is in motion, the seatback should be upright. Always sit well back in the seat and adjust the seat belt properly. (See "Seat belts" later in this screen.)

### **CAUTION:**

When adjusting the seat positions, be sure not to contact any moving parts to avoid possible injuries and/or damages.

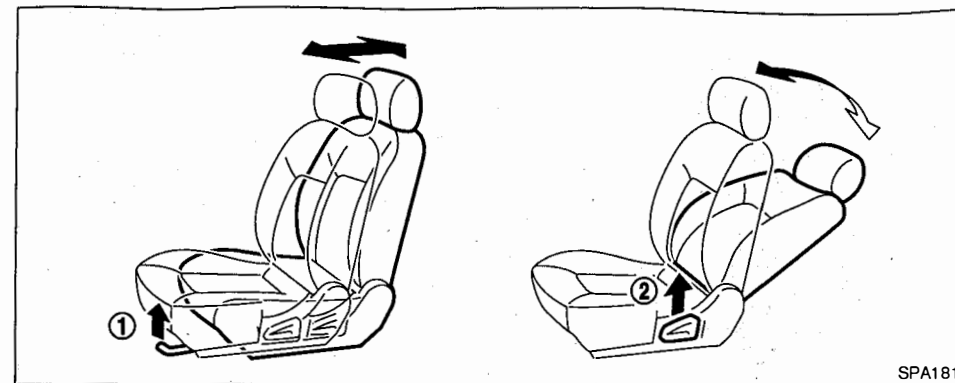

## FRONT SEATS

### Manual seats adjustment

### **⚠ WARNING:**

- Do not adjust the driver's seat while driving. The seat may move suddenly and could cause loss of control of the vehicle.
- After adjustment, check to make sure the seat is securely locked.
- The seatback should not be reclined any more than needed for comfort. Seat belts are most effective when the passenger sits well back and straight up in the seat. If the seat is reclined, the risk

of sliding under the lap belt and being injured is increased.

### Forward and backward:

Pull the lever up ① while you slide the seat forward or backward to the desired position. Release the lever to lock the seat in position.

### Reclining:

To recline the seatback, pull the lever up ② and lean back. To bring the seatback forward again, pull the lever and move your body forward. The seatback will move forward.

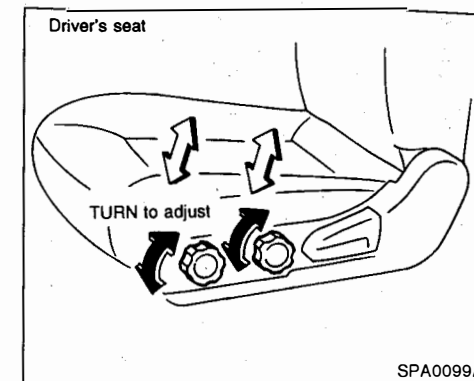

### Seat lifter (if so equipped for driver's seat):

Turn either dial to adjust the angle and height of the seat cushion to the desired position.

## Power seats adjustment

### **! WARNING:**

- Do not adjust the driver's seat while driving in order that full attention may be given to the driving operations.
- Do not leave children unattended inside the vehicle. They could unknowingly activate switches or controls which could cause a serious accident.
- The seatback should not be reclined any more than needed for comfort. Seat belts are most effective when the passenger sits well back and straight up in the seat. If the seat is reclined, the risk of sliding under the lap belt and being injured is increased.

### Operating tips:

- The motor has an auto-reset overload protection circuit. If the motor stops during operation, wait 30 seconds, then reactivate the switch.
- Do not operate the power support seats for a long period of time when the engine is off. This will discharge the battery.

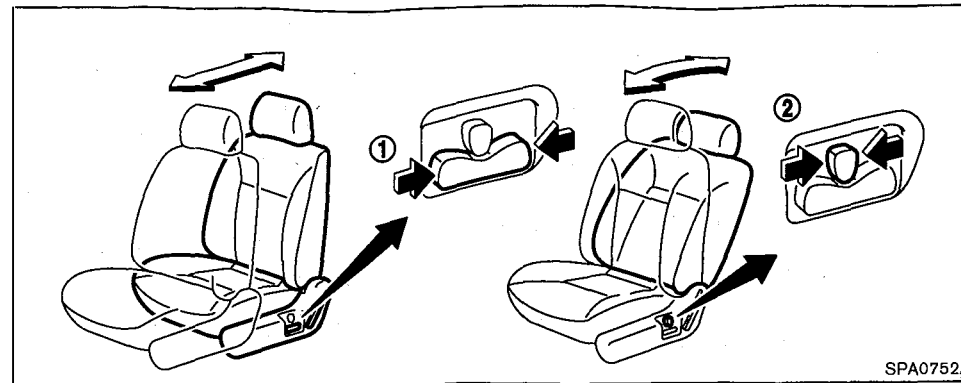

### Forward and backward:

Moving the switch ① forward or backward will slide the seat forward or backward to the desired position.

### Reclining:

Move the recline switch ② backward until the desired angle is obtained. To bring the seat back forward again, move the switch forward and move your body forward. The seatback will move forward.

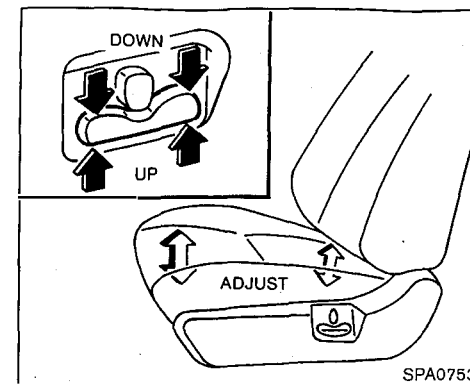

### Seat lifter (driver's seat):

Push the front or rear end of the switch up or down to adjust the angle and height of the seat cushion.

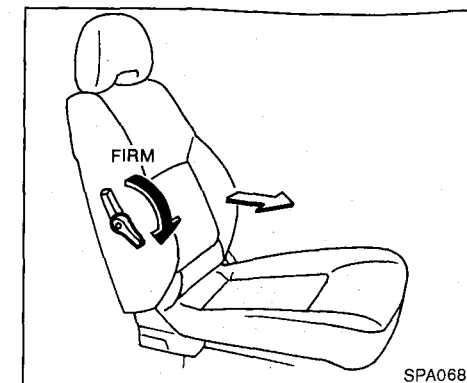

### Lumbar support (if so equipped for driver's seat)

Turn the lever forward or backward to adjust the seat lumbar area.

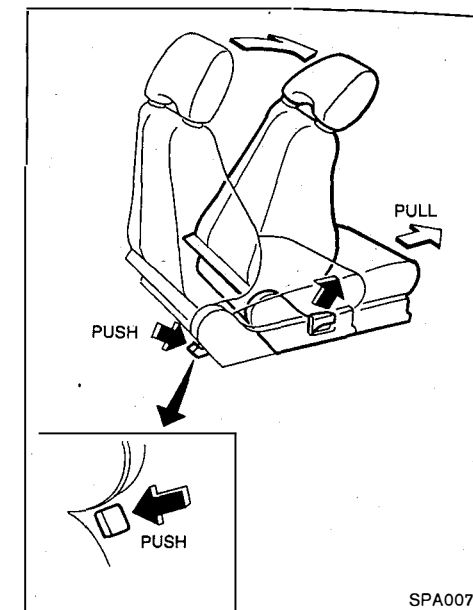

### Tilting front seat (if so equipped for Hardtop models)

The front seatback can be tilted to make it easier for the rear seat passengers to get in and out. To tilt the front seatback, pull the reclining lever up or depress the tilt lever. The seatback will tilt and seat will move forward automatically.

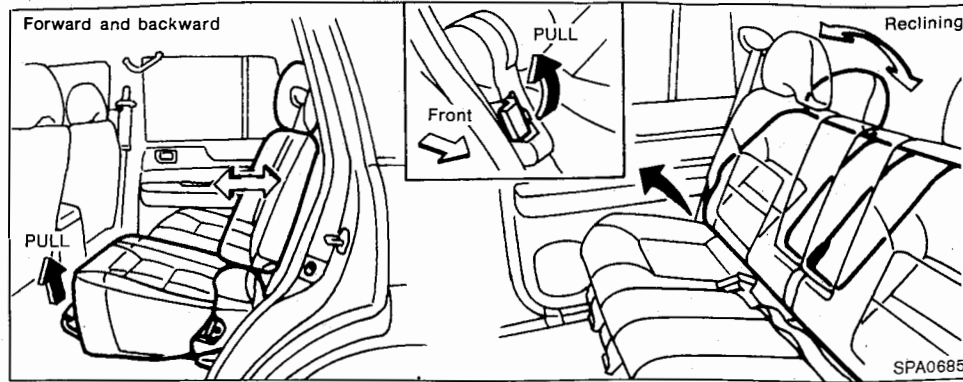

**REAR SEATS (if so equipped)**

**Seats adjustment**

**Forward and backward:**

Pull the lever up while you slide the seat forward or backward to the desired position. Release the lever to lock the seat in position.

**Do not sit in the center position when the right and left seats are not aligned.**

**Reclining:**

To recline the seatback, pull the lever up and lean back. To bring the seatback forward again, pull the lever and move your body forward. The seatback will move forward.

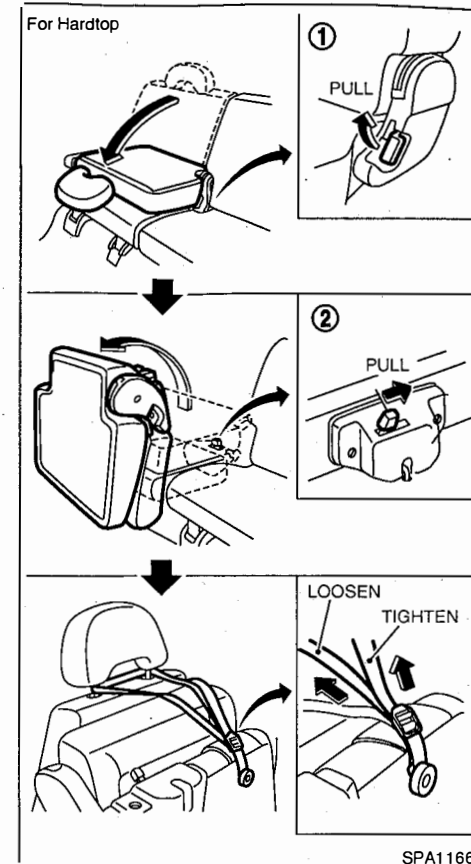
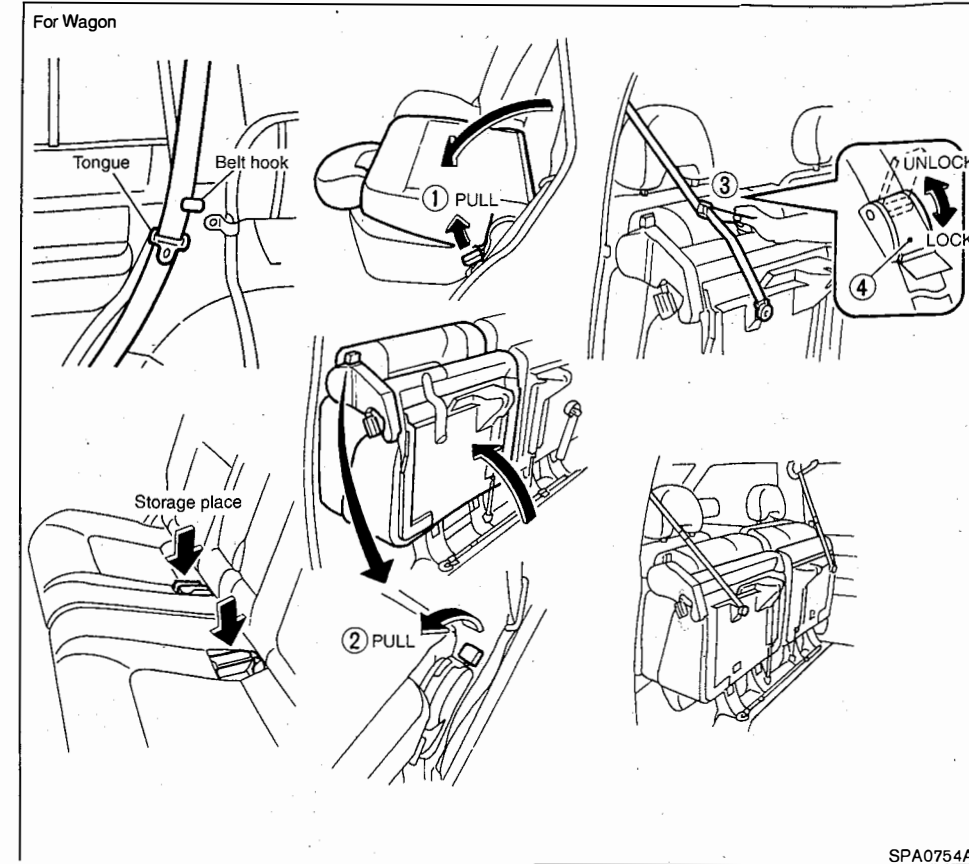

### Folding:

1. Fasten the seat belts to the hooks and put the center seat belt and buckles into the storage place.
2. To fold the seat, pull the lever ① and fold the seatback down.
3. Pull the lever ②, and then lift the rear of the seat cushion and fold it forward.
4. (For Wagon):  
Fasten the strap to the assist grip and tighten it ③. Securely fasten the buckle ④.

(For Hardtop):

Fasten the strap to the head restraint of the front seat.

- If a seat slide mechanism is equipped, move the seat rearward and fold the seatback.
- When resetting the seat, be sure to pull the seat belts and buckles out from the hooks and storage place.

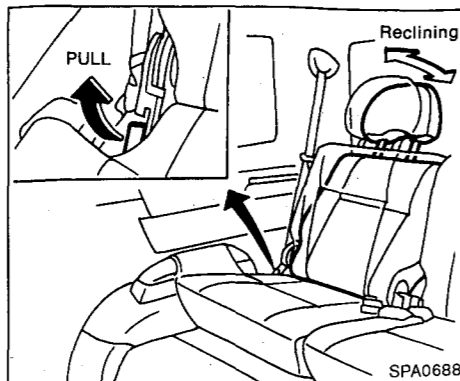

### 3RD SEATS (if so equipped)

#### Seats adjustment

#### Reclining:

To recline the seatback, pull the lever up and lean back. To bring the seatback forward again, pull the lever and move your body forward. The seatback will move forward.

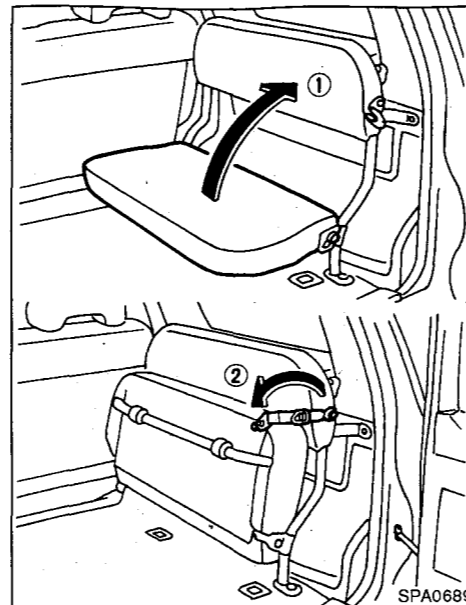

#### Folding (side facing seat):

1. Lift the seat cushion ①.
2. Secure the seat cushion with the strap ②.

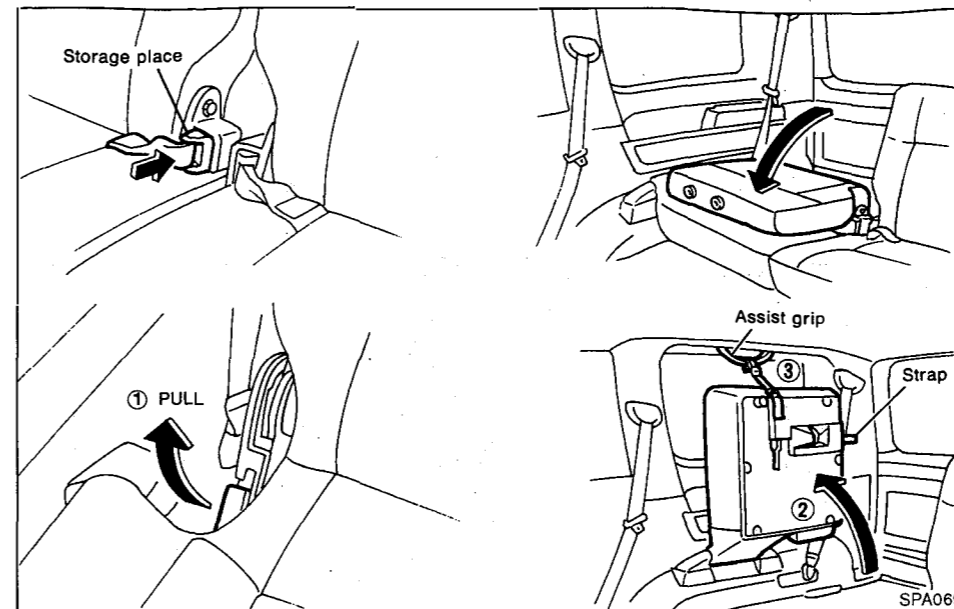

#### Folding (front facing seat):

1. Put the 3rd seat belt buckle into the storage place.
2. Remove the head restraint.
3. To fold the seat, pull the lever ① and fold the seatback down.
4. Pull the strap and fold to the side ②.

5. Fasten the band hook to the assist grip and tighten it ③.

**The removed head restraint should be securely stored.**

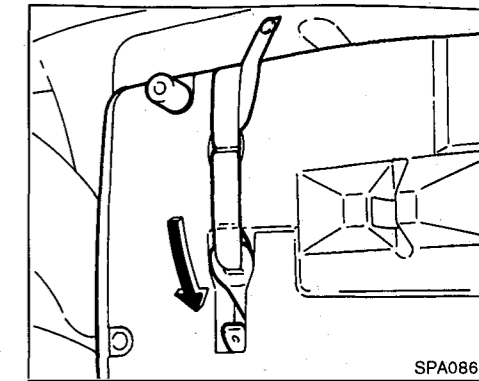

**When resetting the seat, be sure to put back the band hook, install the head restraint and pull the seat belt buckle out from the storage place.**



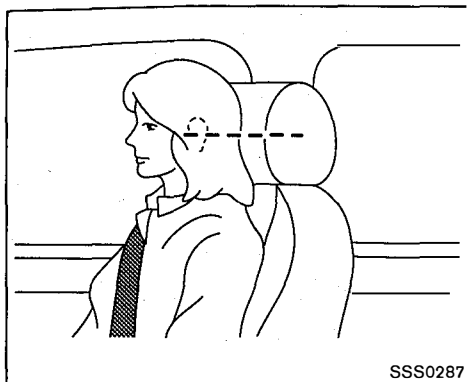

SSS0287

## HEAD RESTRAINTS



### WARNING:

**Do not drive and/or ride in the vehicle with the head restraint removed. This can be dangerous. Head restraints should be adjusted properly as they may provide significant protection against injury in an accident. Check the height after someone else uses the seat.**

The proper adjustment of the head restraint is as illustrated.

Adjust the head restraint so that the head restraint's center is level with the center of the ears.

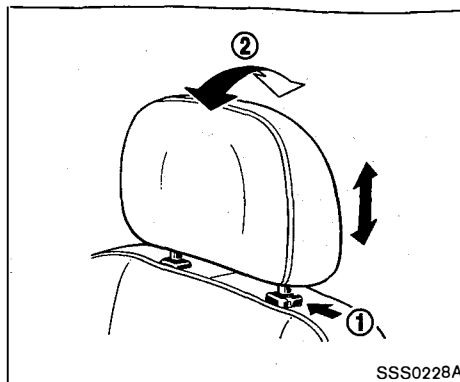

SSS0228A

## Adjustment

1. Pull up the head restraint to raise to the proper position.
2. Push in the lock knob ① and push down the head restraint to lower to the proper position.
3. Tilt the head restraint to the desired position ②. (if so equipped)

The adjustable rear head restraint should only be used in the notched stem positions. The lowest head restraint position is the stowed position.

When removing the rear head restraint for seat folding etc., push the lock knob and pull up the head restraint. The removed head restraint should be securely stored.

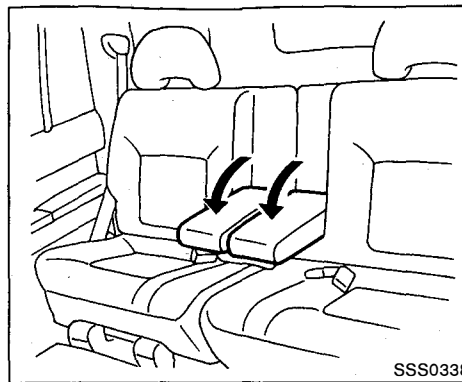

SSS0338

Wagon model

## ARMREST

Rear seat (if so equipped)

Pull the armrest forward and lay it horizontal.

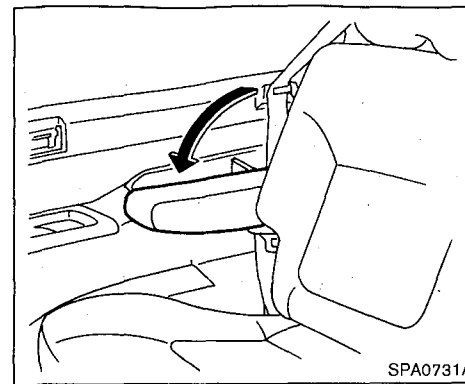

SPA0731A

Hardtop model

## SEAT BELTS

### PRECAUTIONS ON SEAT BELT USAGE

If you are wearing the seat belt properly adjusted and sitting upright and well back in the seat, chances of being injured or killed in an accident and/or the severity of injury may be greatly reduced. NISSAN strongly encourages you and all of your passengers to buckle up every time you drive, even if your seating position includes the supplemental air bag systems.

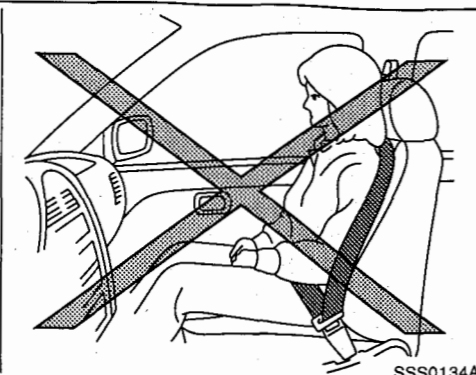
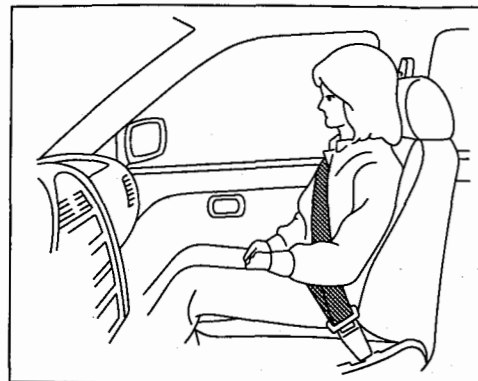

SSS0134A



SSS0014

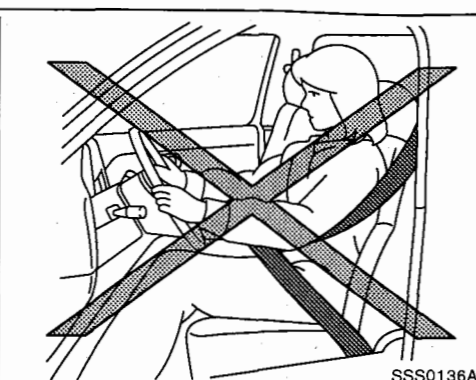
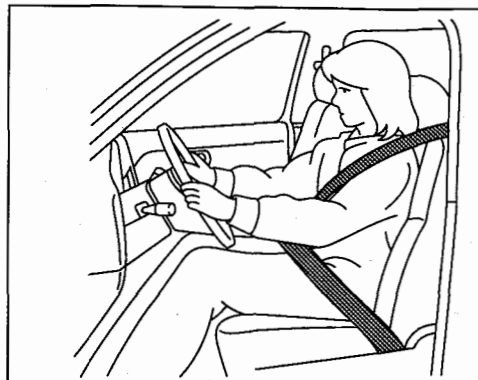

SSS0136A

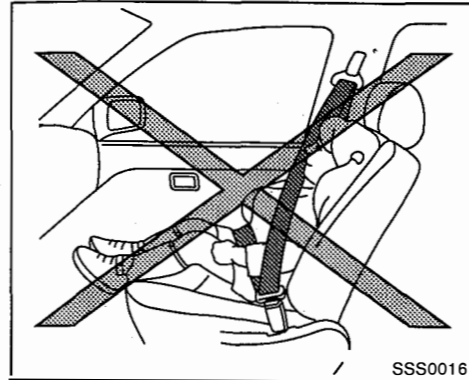

SSS0016

**! WARNING:**

- Seatbelts are designed to bear upon the bony structure of the body, and should be worn low across the front of the pelvis or the pelvis, chest and shoulders, as applicable; wearing the lap section of the belt across the abdominal area must be avoided. Serious injury may occur if a seat belt is not worn properly.
- Position the lap belt as low and snug as possible around the hips, not the waist. A lap belt worn too high could increase the risk of internal injuries in an accident.
- Do not allow more than one person to use the same seat belt. Each belt assembly must only be used by one occupant; it is dangerous to put a belt around a child being carried on the occupant's lap.
- Never carry more people in the vehicle than there are seat belts.
- Never wear seat belts inside out. Belts should not be worn with straps twisted. Doing so may reduce their effectiveness.
- Seatbelts should be adjusted as firmly as possible, consistent with comfort, to

provide the protection for which they have been designed. A slack belt will greatly reduce the protection afforded to the wearer.

- Every person who drives or rides in this vehicle should use a seat belt at all times. Children should be properly restrained in the rear seat and, if appropriate, in a child restraint system.
- Do not run the belt behind your back or under your arm. Always route the shoulder belt over your shoulder and across your chest. The belt should be away from your face and neck, but not falling off your shoulder. Serious injury may occur if a seat belt is not worn properly.
- No modifications or additions should be made by the user which will either prevent the seat belt adjusting devices from operating to remove slack, or prevent the seat belt assembly from being adjusted to remove slack.
- Care should be taken to avoid contamination of the webbing with polishes, oils and chemicals, and particularly battery acid. Cleaning may safely be carried out using mild soap and water. The belt should be replaced if webbing becomes frayed, contaminated or damaged.

- It is essential to replace the entire assembly after it has been worn in a severe impact even if damage to the assembly is not obvious.
- All seat belt assemblies including retractors and attaching hardware should be inspected after any collision by a NISSAN dealer. NISSAN recommends that all seat belt assemblies in use during a collision be replaced unless the collision was minor and the belts show no damage and continue to operate properly. Seat belt assemblies not in use during a collision should also be inspected and, when necessary, replaced if either damage or improper operation is noted.
- Once the pre-tensioner seat belt has activated, it cannot be reused. It must be replaced together with the retractor. Contact a NISSAN dealer.
- Removal and installation of the pre-tensioner seat belt system components should be done by a NISSAN dealer.

**CHILD SAFETY**

**! WARNING:**

- Infants and children need special protection. The vehicle's seat belts may not

fit them properly. The shoulder belt may come too close to the face or neck. The lap belt may not fit over their small hipbones. In an accident, an improperly fitted seat belt could cause serious or fatal injury.

- Always use an appropriate child restraint system.

Children need adults to help protect them. They need to be properly restrained. The proper restraint depends on the child's size.

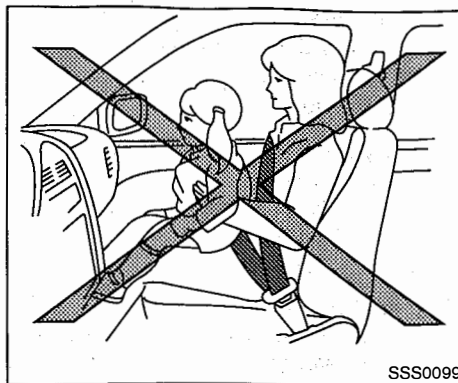

#### Infants and small children

NISSAN recommends that infants and small children be seated in a child restraint system. You should choose a child restraint system that fits your vehicle and the child, and always follow the manufacturer's instructions for installation and use.

#### Large children



**WARNING:**

- Never allow children to stand or kneel on any seats.
- Never allow children in the cargo areas while the vehicle is moving. A child

#### could be seriously injured in an accident or sudden stop.

Children who are too large for a child restraint system should be seated and restrained by the seat belts that are provided.

If the child's seating position has a shoulder belt that fits close to the face or neck, the use of a booster seat (commercially available) may help overcome this. The booster seat should raise the child so that the shoulder belt is properly positioned across the top, middle portion of the shoulder and the lap belt is low on the hips. The booster seat should also fit the vehicle seat. Once the child has grown so that the shoulder belt is no longer on or near the face or neck of the child, use the shoulder belt without the booster seat. In addition, there are many types of child restraint systems available for larger children that should be used for maximum protection.

#### PREGNANT WOMEN

NISSAN recommends that pregnant women use seat belts. The seat belt should be worn snug, and always position the lap belt as low as possible around the hips, not the waist. Place the shoulder belt over your shoulder and across your chest. Never run the lap/shoulder belt over your abdominal area. Contact your doctor for specific recommendations.

#### INJURED PERSONS

NISSAN recommends that injured persons use seat belts. Contact your doctor for specific recommendations.

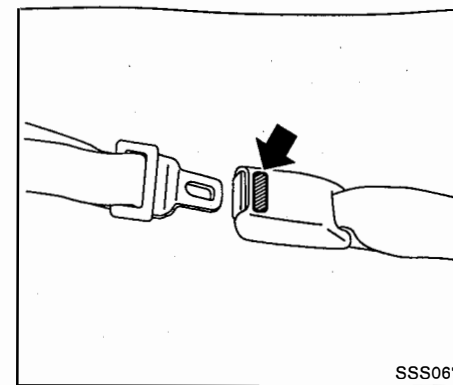

#### CENTER MARK ON SEAT BELTS (if so equipped)

#### Selecting correct set of seat belts

The center seat belt buckle is identified by the CENTER mark. The center seat belt tongue can be fastened only into the center seat belt buckle.

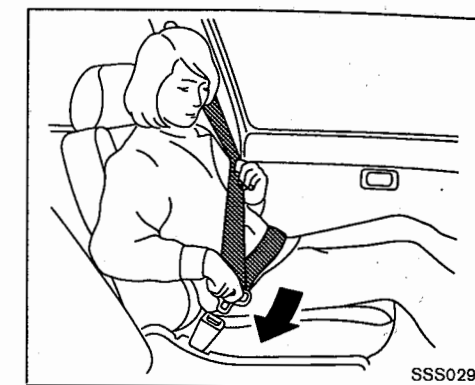

#### THREE-POINT TYPE SEAT BELTS



**WARNING:**

- Every person who drives or rides in this vehicle should use a seat belt at all times.
- The seatback should not be in a reclined position any more than needed for comfort. Seat belts are most effective when the passenger sits well back and straight up in the seat.

#### Fastening seat belts

1. Adjust the seat. (See "Seats" earlier in this section.)

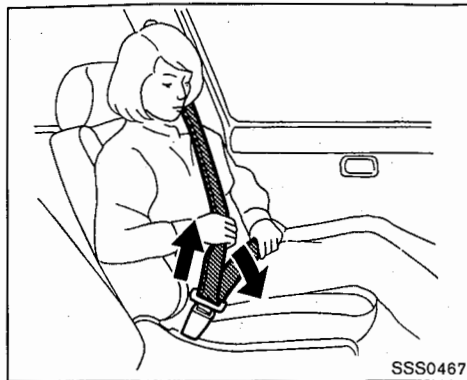

2. Slowly pull the seat belt out of the retractor and insert the tongue into the buckle until you hear and feel the latch engage.

**The retractor is designed to lock during a sudden stop or on impact. A slow pulling motion permits the seat belt to move, and allows you some freedom of movement in the seat.**

3. Position the lap belt portion low and snug on the hips as shown.
4. Pull the shoulder belt portion toward the retractor to take up extra slack. Be sure the shoulder belt is routed over your shoulder and is snug across your chest.

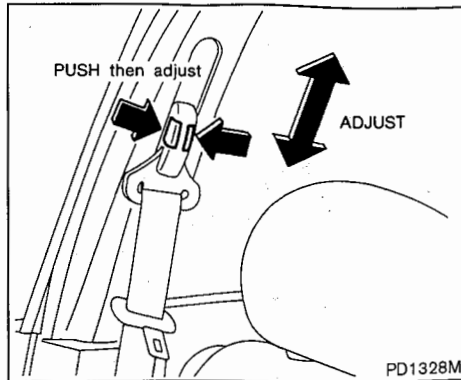

Shoulder belt height adjustment (if so equipped)

**WARNING:**

- **The shoulder belt anchor height should be adjusted to the position best for you. Failure to do so may reduce the effectiveness of the entire restraint system and increase the chance or severity of injury in an accident.**
- **The shoulder belt should rest on the middle of the shoulder. It must not rest against the neck.**
- **Be sure that the seat belt is not twisted in any way.**

- **Be sure that the shoulder belt anchor is secured by trying to move the shoulder belt anchor up and down after adjustment.**

The shoulder belt anchor height should be adjusted to the position best for you.

The belt should be away from your face and neck, but not falling off your shoulder.

To adjust, push the release button and move the shoulder belt anchor to the proper position, so that the belt passes over the center of the shoulder.

Release the button to lock the shoulder belt anchor into position.

**Unfastening seat belts**

Push the button on the buckle. The seat belt automatically retracts.

**Automatic locking mode (if so equipped)**

The rear three-point seat belts (except center seat belt) have an automatic lock mechanism to use when installing a child restraint system. This mechanism is referred to as the automatic locking mode.

If the seat belt is fully extended, the automatic lock mechanism will be activated and the seat

belt can only retract. The seat belt will not be able to extend unless the seat belt is fully retracted once.

To deactivate the automatic locking mode, detach the seat belt tongue from the buckle and fully retract the belt to its storing position.

**CAUTION:**

**The automatic locking mode should be used only for installation of a child restraint system. During normal seat belt use by a passenger, the automatic locking mode should not be activated. The use of the automatic locking mode by a passenger may cause uncomfortable seat belt tension.**

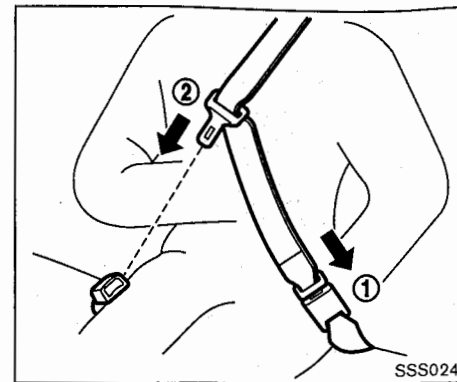

Three-point type rear center seat belt (if so equipped)

The rear center seat belt has a connector tongue ① and a seat belt tongue ②. Both the connector tongue and the seat belt tongue must be securely latched for proper seat belt operation.

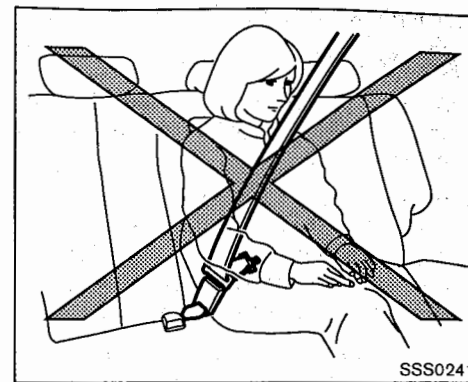

**WARNING:**

- **Always fasten the connector tongue and the seat belt in the order shown.**
- **Always make sure both the connector tongue and the seat belt tongue are secured when using the seat belt. Do not use it with only the seat belt tongue attached. This could result in serious personal injury in case of an accident or a sudden stop.**

### Stowing rear center seat belt:

#### WARNING:

- Do not unfasten the rear center seat belt connector except when folding down the rear seat.
- When attaching the rear center seat belt connector, be certain that the seatbacks are completely secured in the latched position and the rear center seat belt connector is completely secured.
- If the rear center seat belt connector and the seatbacks are not secured in the correct position, serious personal injury may result in an accident or sudden stop.

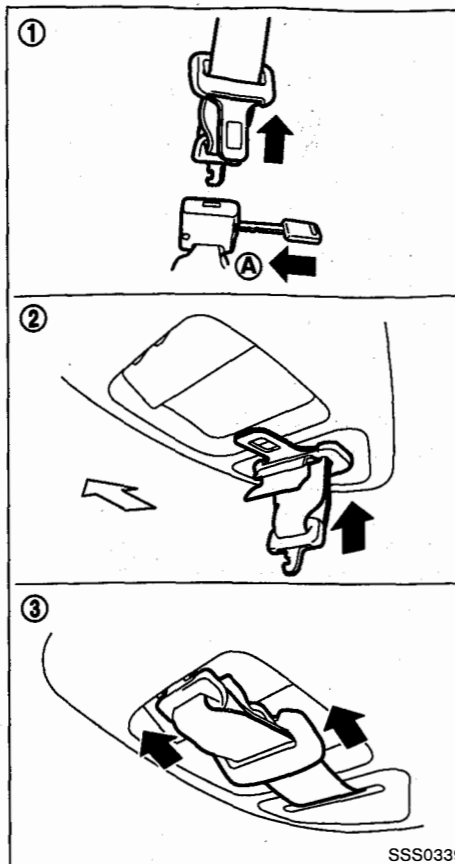

When folding down the rear seat, the rear center seat belt can be retracted into a stowed position as follows:

1. Hold the connector tongue so that the seat belt does not retract suddenly when the tongue is released from the connector buckle.
2. Insert a suitable tool such as a key **A** into the connector buckle and release the connector tongue.
3. Retract the seat belt up to the retractor base.
4. Secure the seat belt tongue and connector tongue into the retractor base.

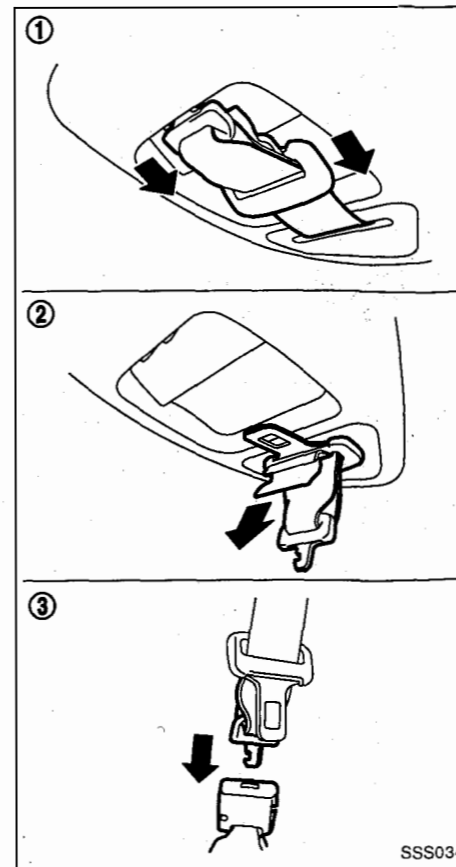

### Attaching rear center seat belt:

Always be sure the rear center seat belt connector tongue and connector buckle are attached. Disconnect only when folding down the rear seat.

To connect the buckle:

1. Pull out the connector tongue and seat belt tongue from the retractor base.
2. Pull the seat belt.
3. Secure the connector tongue to the connector buckle until it clicks.

The center seat belt connector tongue and buckle are indicated by the "▼" and "▲" mark.

The center seat belt connector tongue can be attached only into the rear center seat belt connector buckle.

#### WARNING:

- Do not unfasten the rear center seat belt connector except when folding down the rear seat.
- When attaching the rear center seat belt connector, be certain that the seatbacks are completely secured in the latched position and the rear center seat belt connector is completely secured.

- If the rear center seat belt connector and the seatbacks are not secured in the correct position, serious personal injury may result in an accident or sudden stop.

### Checking seat belts operation

Seat belt retractors are designed to lock seat belt movement:

- When the seat belt is pulled quickly from the retractor.
- When the vehicle slows down rapidly.

To increase your confidence in the seat belts, check the operation by grasping the shoulder belt and pulling forward quickly. The retractor should lock and restrict further belt movement. If the retractor does not lock during this check, contact a NISSAN dealer immediately.

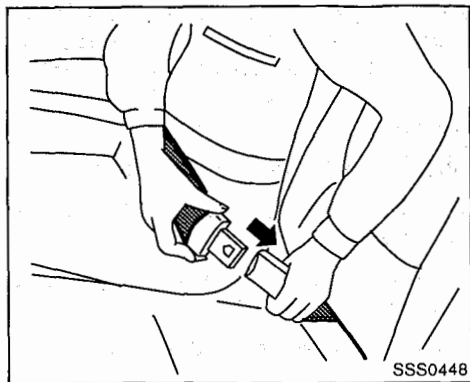

TWO-POINT TYPE SEAT BELTS (if so equipped)

**WARNING:**

Every person who drives or rides in this vehicle should use a seat belt at all times.

Fastening seat belts

**WARNING:**

The seatback should not be in a reclined position any more than needed for comfort. Seat belts are most effective when the passenger sits well back and straight up in the seat.

1. Insert the tongue into the buckle marked

CENTER until you hear and feel the latch engage.

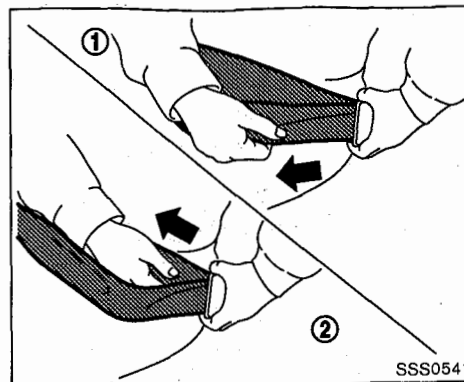

2. Adjust the seat belt length. To shorten, hold the tongue and pull the upper belt as illustrated ①. To lengthen, hold the tongue and pull the under belt as illustrated ②.

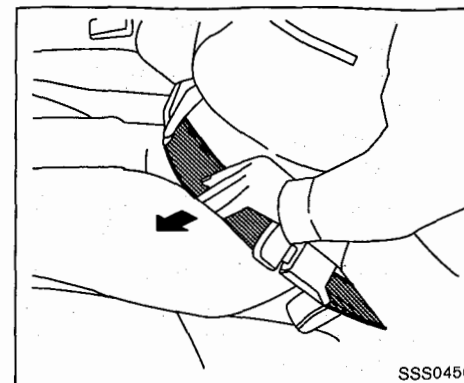

3. Position the lap belt portion low and snug on the hips as shown.

Unfastening seat belts

Push the button on the buckle.

Fasten the seat belts when not in use to prevent them from being caught in the door.

SEAT BELT MAINTENANCE

Periodically check that the seat belt and all the metal components, such as buckles, tongues, retractors, flexible wires and anchors, work properly. If loose parts, deterioration, cuts or other damage on the seat belt webbing is found, the entire seat belt assembly should be replaced.

If dirt builds up in the shoulder belt guide of the seat belt anchors, the seat belts may retract slowly. Wipe the shoulder belt guide with a clean, dry cloth.

To clean the seat belt webbing, apply a mild soap solution or any solution recommended for cleaning upholstery or carpet. Then wipe with a cloth and allow the seat belts to dry in the shade. Do not allow the seat belts to retract until they are completely dry.

CHILD RESTRAINTS

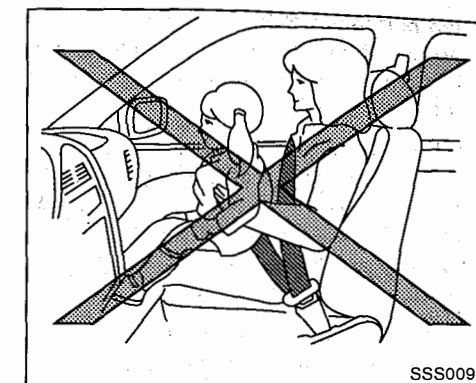

PRECAUTIONS ON CHILD RESTRAINTS USAGE

**WARNING:**

- Infants and small children should never be carried on your lap. It is not possible for even the strongest adult to resist the forces of a severe accident. The child could be crushed between the adult and parts of the vehicle. Also, it is dangerous to put a seat belt around a child being carried on the occupant's lap.
- Infants and children need special protection. The vehicle's seat belts may not fit them properly. The shoulder belt may come too close to the face or neck. The

lap belt may not fit over their small hip bones. In an accident, an improperly fitting seat belt could cause serious or fatal injury.

- Infants and small children should always be placed in an appropriate child restraint system while riding in the vehicle. Failure to use a child restraint system can result in serious injury or death.
- Child restraint systems specially designed for infants and small children are available from several manufacturers. When selecting any child restraint systems, place your child in the child restraint system and check the various adjustments to be sure that the child restraint system is compatible with your child. Always follow the manufacturer's instructions for installation and use.
- NISSAN recommends that the child restraint system be installed in the rear seat. According to accident statistics, children are safer when properly restrained in the rear seat rather than in the front seat.
- Follow all of the child restraint system manufacturer's instructions for installation and use. When purchasing a child

restraint system, be sure to select one which will fit your child and vehicle. It may not be possible to properly install some types of child restraint systems in your vehicle.

- For a front-facing child restraint system, check to make sure the shoulder belt does not fit close to child's face or neck. If it does, put the shoulder belt behind the child restraint system.
- For models equipped with the front passenger air bag, never install a rear-facing child restraint system in the front seat. An inflating supplemental front-impact air bag could seriously injure or kill your child. A rear-facing child restraint system must only be used in the rear seat.
- Adjustable seatbacks should be positioned to fit a child restraint system, but as upright as possible.
- If the seat belt in the position where a child restraint system is installed requires a locking clip and if it is not used, injuries could result from a child restraint system tipping over during normal vehicle braking or cornering.
- After attaching a child restraint system,

test it before you place the child in it. Tilt it from side to side. Try to tug it forward and check if it is held securely in place. If the restraint is not secure, tighten the belt as necessary, or install the restraint in another seat and test it again.

- Check the child restraint system in your vehicle to be sure that it is compatible with the vehicle's seat belt system.
- If a child restraint system is not anchored properly, the risk of a child being injured in a collision or a sudden stop greatly increases.
- Improper use of a child restraint system can increase the risk or severity of injury for both the child and other occupants in the vehicle.
- Always use an appropriate child restraint system. An improperly installed child restraint system could lead to serious injury or death in an accident.
- When the child restraint system is not in use, keep it secured with a seat belt to prevent it from being thrown around in case of a sudden stop or accident.

NISSAN recommends that infants and small children be seated in a child restraint system. You should choose a child restraint system that

fits your vehicle and always follow the manufacturer's instructions for installation and use. In addition, there are many types of child restraint systems available for larger children that should be used for maximum protection.

#### CAUTION:

Remember that a child restraint system left in a closed vehicle can become very hot. Check the seating surface and buckles before placing your child in a child restraint system.

#### UNIVERSAL CHILD RESTRAINTS FOR FRONT PASSENGER SEAT AND REAR SEATS (for Europe)

When selecting any child restraint, keep the following points in mind:

- Choose a child restraint that complies with the latest European safety standard, ECE Regulation No. 44.03.
- Place your child in the child restraint and check the various adjustments to be sure the child restraint is compatible with your child. Always follow all of the recommended procedures.
- Check the child restraint in your vehicle to be sure it is compatible with vehicle's seat belt system.

- Refer to the tables later in this section for a list of the recommended fitment positions and the approved child restraints for your vehicle.

### Approved child restraint positions

Age group	Seating position				
	Front passenger with air bag	Front passenger without air bag	Rear center	Rear outer	3rd row outboard (if so equipped)
< 10 kg (0 to 9 months)	X	LR	X	LR	LR
< 13 kg (0 to 24 months)	X	X	X	X	X
9 to 18 kg (9 to 48 months)	LF	L	L	L	L
15 to 36 kg (4 to 12 years)	LF	L	L	L	L

X: Seat position not suitable for restraints in this age group.  
 L: Suitable for particular child restraints given in the following table.  
 LF: Suitable for particular front facing child restraints given in the following table.  
 LR: Suitable for particular rear facing child restraints given in the following table.

**NOTE:**

**Universal child restraints approved to ECE Regulation No. 44.03 are clearly marked "Universal".**

### List of approved child restraints

Age group	Seating position				
	Front passenger with air bag	Front passenger without air bag	Rear center	Rear outer	3rd row outboard (if so equipped)
< 10 kg (0 to 9 months)	X	Romer Baby Safe	X	Romer Baby Safe	Romer Baby Safe
< 13 kg (0 to 24 months)	X	X	X	X	X
9 to 18 kg (9 to 48 months)	Romer King Romer Peggy	Romer King Romer Peggy	Romer King Romer Peggy	Romer King Romer Peggy	Romer King Romer Peggy
15 to 36 kg (4 to 12 years)	Romer Vario Romer Star Riser	Romer Vario Romer Star Riser	Romer Vario	Hardtop models: Romer Vario Wagon models: Romer Vario Romer Star Riser	Romer Vario



**WARNING:**

**In vehicles equipped with a side air bag system, do not let any infants or small children sit in the front passenger's seat as the air bag may cause serious injury in case of deployment during a collision.**



## INSTALLATION OF CHILD RESTRAINT SYSTEM

Installation on rear seats - seat belts with automatic locking mode

### ⚠ WARNING:

- The rear three-point seat belts on your vehicle are equipped with automatic locking mode retractors. The three-point seat belts must be used when installing a child restraint system.
- Failure to use the rear three-point seat belts will result in the child restraint system not being properly secured. It could tip over or otherwise be unsecured and cause injury to the child in a sudden stop or collision.
- The direction of the child restraint system depends on the type of the child restraint system and the size of the child.

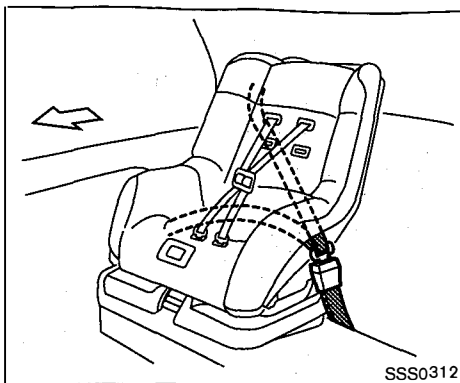

Rear outboard

### Front-facing:

When you install a front-facing child restraint system in the rear seat, follow these steps:

1. Position the front-facing child restraint system on the rear seat.

Always follow the child restraint system manufacturer's instructions for installation.

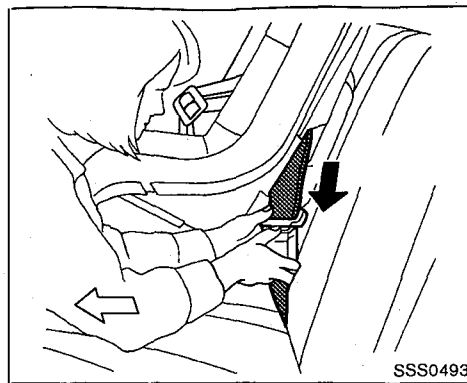

SSS0493

2. Route the seat belt tongue through the child restraint system and insert it into the buckle until you hear and feel the latch engage.

Be sure to follow the child restraint system manufacturer's instructions for belt routing.

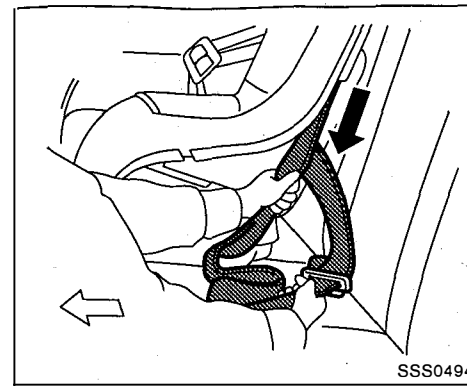

SSS0494

3. Pull out the shoulder belt until the entire belt is extended to change the locking mode to automatic locking.

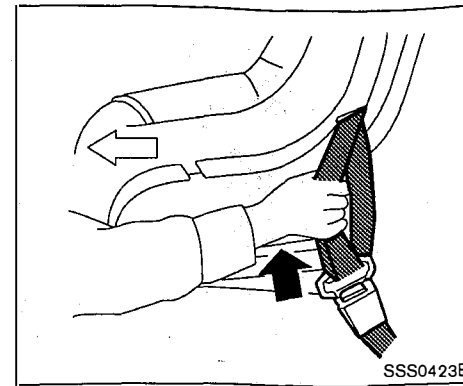

SSS0423B

4. Allow the seat belt to retract. Pull up the shoulder belt to remove any slack in the belt.
5. Test the child restraint system before you place the child in it. Tilt it from side to side. Try to tug it forward and check if it is held securely in place.
6. Check that the retractor is in the automatic locking mode by trying to pull more of the seat belt out of the retractor. If you cannot pull any more belt webbing out of the retractor, the retractor is in the automatic locking mode.
7. Make sure that the child restraint system is properly secured prior to each use. If the seat belt is not locked, repeat steps 3 through 6.

After the child restraint system is removed and the seat belt is fully retracted, the automatic locking mode is cancelled and returned to the emergency locking mode.

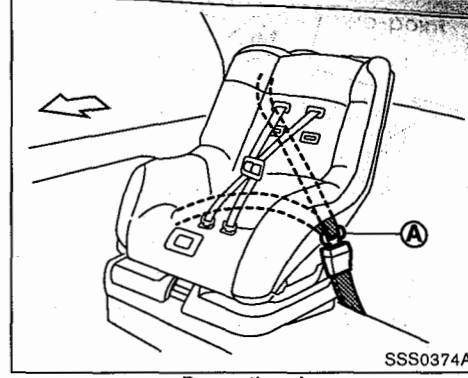
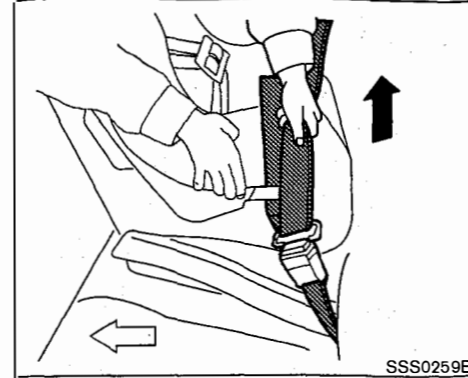
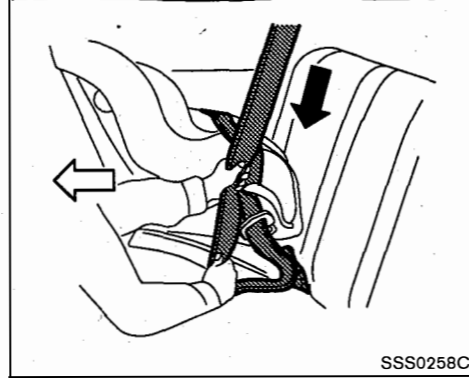
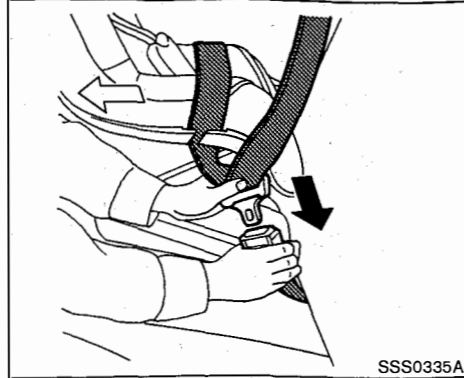
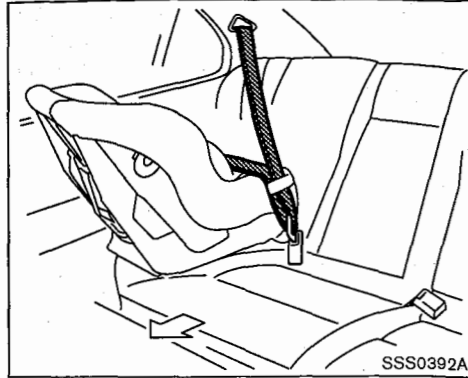

**Rear-facing:**

When you install a rear-facing child restraint system in the rear seat, follow these steps:

1. Position the rear-facing child restraint system on the rear seat.

Always follow the child restraint system manufacturer's instructions for installation.

2. Route the seat belt tongue through the child restraint system and insert it into the buckle until you hear and feel the latch engage.

Be sure to follow the child restraint system manufacturer's instructions for belt routing.

3. Pull out the shoulder belt until the entire belt is extended to change the locking mode to automatic locking.

4. Allow the seat belt to retract. Pull up the shoulder belt to remove any slack in the belt.

5. Test the child restraint system before you place the child in it. Tilt it from side to side. Try to tug it forward and check if it is held securely in place.

6. Check that the retractor is in the automatic locking mode by trying to pull more of the seat belt out of the retractor. If you cannot pull any more belt webbing out of the retractor, the retractor is in the automatic locking mode.

7. Make sure that the child restraint system is properly secured prior to each use. If the seat belt is not locked, repeat steps 3 through 6.

After the child restraint system is removed and the seat belt is fully retracted, the automatic locking mode is cancelled and returned to the emergency locking mode.

Installation on rear seats - three-point type seat belts without automatic locking mode

**WARNING:**

- The three-point type seat belt on your vehicle is not equipped with an automatic locking mode retractor.
- The direction of the child restraint system depends on the type of the child restraint system and the size of the child.

**Front-facing:**

If you must install a front-facing child restraint system on the rear seat, follow these steps:

1. Position the front-facing child restraint system on the rear seat.

Always follow the child restraint system manufacturer's instructions for installation and use.

2. Route the seat belt tongue through the child restraint system and insert it into the buckle until you hear and feel the latch engage.

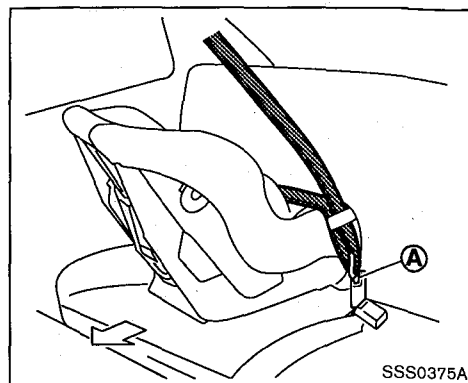

Rear center

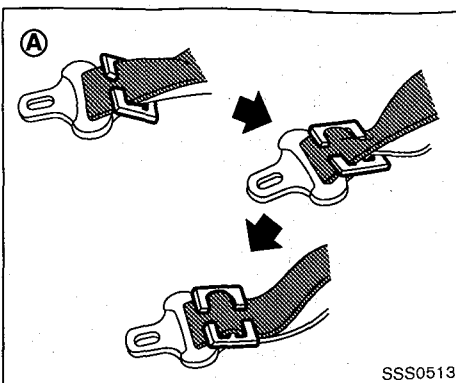

Rear outboard

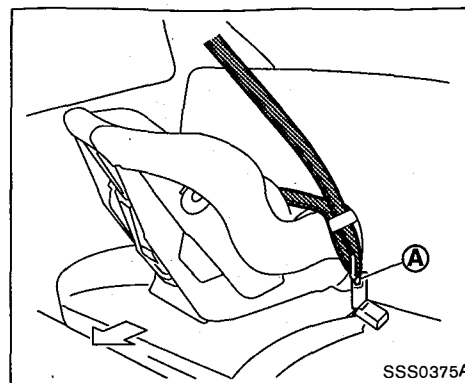

Rear center

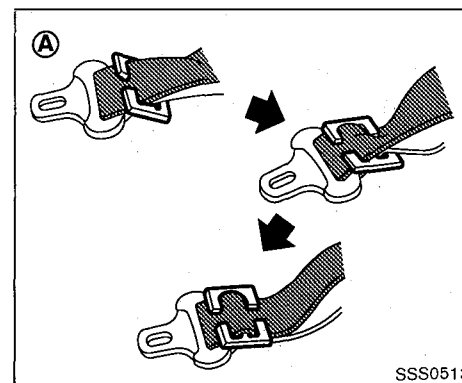
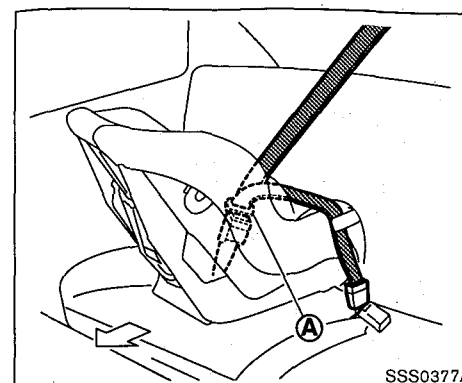

3. To prevent slack in the lap belt, it is necessary to secure the shoulder belt in place with a locking clip (A). Use the locking clip attached to the child restraint system or one which is equivalent in dimension and strength.

Be sure to follow the child restraint system manufacturer's instructions for belt routing.

4. Test the child restraint system before you place the child in it. Tilt it from side to side. Try to tug it forward and check if it is held securely in place.
5. Make sure that the child restraint system is properly secured prior to each use.

#### Rear-facing:

If you must install a rear-facing child restraint system on the rear seat, follow these steps:

1. Position the rear-facing child restraint system on the rear seat.

Always follow the child restraint system manufacturer's instructions for installation and use.

2. Route the seat belt tongue through the child restraint system and insert it into the buckle until you hear and feel the latch engage.

3. To prevent slack in the lap belt, it is necessary to secure the shoulder belt in place with a locking clip (A). Use the locking clip attached to the child restraint system or one which is equivalent in dimension and strength.

Be sure to follow the child restraint system manufacturer's instructions for belt routing.

4. Test the child restraint system before you place the child in it. Tilt it from side to side. Try to tug it forward and check if it is held securely in place.
5. Make sure that the child restraint system is properly secured prior to each use.

Installation on rear seats - two-point type seat belts

#### ⚠ WARNING:

- NISSAN recommends that the child restraint system be installed in a seat equipped with the three-point type seat belt.
- The direction of the child restraint system depends on the type of the child restraint system and the size of the child.

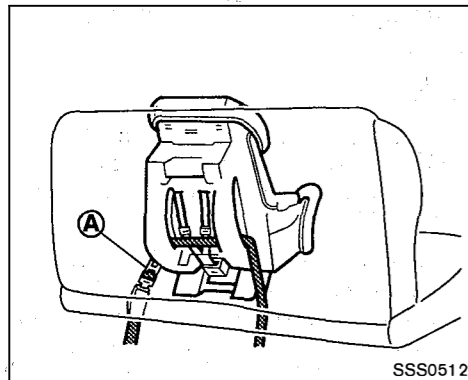

### Front-facing:

If you must install a front-facing child restraint system on the rear center seat equipped with the two-point type seat belt, follow these steps:

1. Position the front-facing child restraint system on the rear center seat.

Always follow the child restraint system manufacturer's instructions for installation and use.

2. Route the seat belt tongue through the child restraint system and insert it into the buckle until you hear and feel the latch engage.

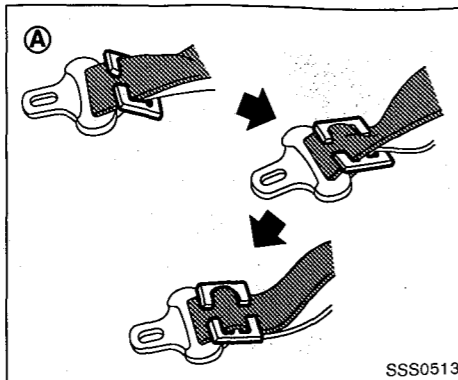

3. To prevent slack in the lap belt, it is necessary to secure the lap belt in place with a locking clip (A). Use the locking clip or another locking device attached to the child restraint system.

Be sure to follow the child restraint system manufacturer's instructions for belt routing.

4. Test the child restraint system before you place the child in it. Tilt it from side to side. Try to tug it forward and check if it is held securely in place.
5. Make sure that the child restraint system is properly secured prior to each use.

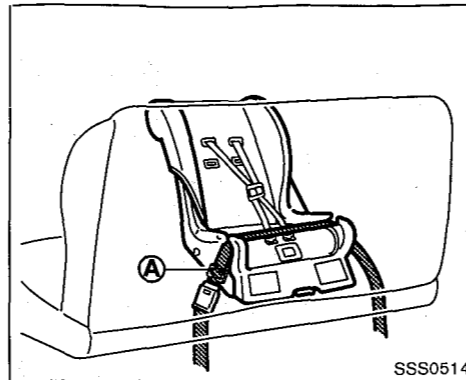

### Rear-facing:

If you must install a rear-facing child restraint system on the rear center seat equipped with the two-point type seat belt, follow these steps:

1. Position the rear-facing child restraint system on the rear center seat.

Always follow the child restraint system manufacturer's instructions for installation and use.

2. Route the seat belt tongue through the child restraint system and insert it into the buckle until you hear and feel the latch engage.

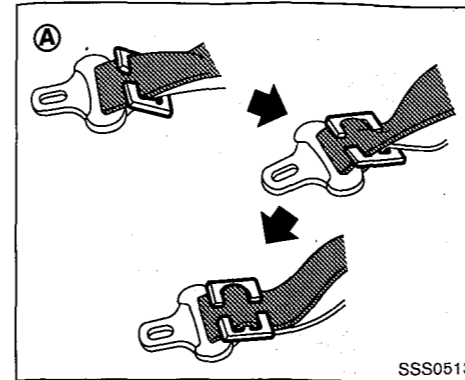

3. To prevent slack in the lap belt, it is necessary to secure the lap belt in place with a locking clip (A). Use the locking clip or another locking device attached to the child restraint system.

Be sure to follow the child restraint system manufacturer's instructions for belt routing.

4. Test the child restraint system before you place the child in it. Tilt it from side to side. Try to tug it forward and check if it is held securely in place.
5. Make sure that the child restraint system is properly secured prior to each use.

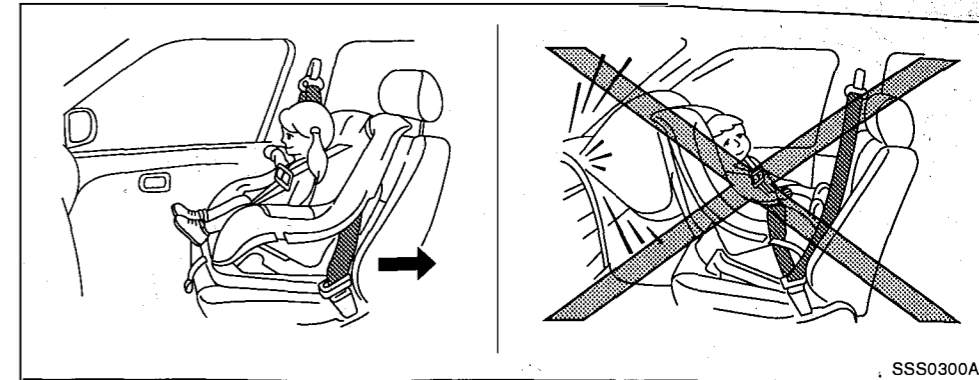

Installation on front seat - with front passenger air bag

### ! WARNING:

- Never install a rear-facing child restraint system on the front seat. Inflating supplemental front-impact air bags inflate with great force. A rear-facing child restraint system could be struck by the supplemental front-impact air bags in an accident and could seriously injure or kill your child.
- NISSAN recommends that a child restraint system be installed on the rear seat. However, if you must install a front-facing child restraint system in the

front passenger's seat, move the passenger's seat to the rearmost position.

- Child restraint systems for infants must be used in the rear-facing direction and therefore must not be used on the front seat.
- Do not install a child restraint system in the center position of the front bench seat. This position is not suitable for the installation of a child restraint system.

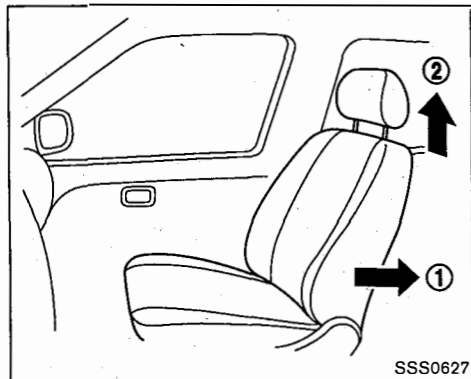

#### Front-facing:

If you must install a front-facing child restraint system on the front seat, follow these steps:

1. Move the seat to the rearmost position ①.
2. Adjust the head restraint to its highest position ②.
3. Position the front-facing child restraint system on the front passenger's seat. It should be placed in the front-facing direction only.

Always follow the child restraint system manufacturer's instructions for installation and use.

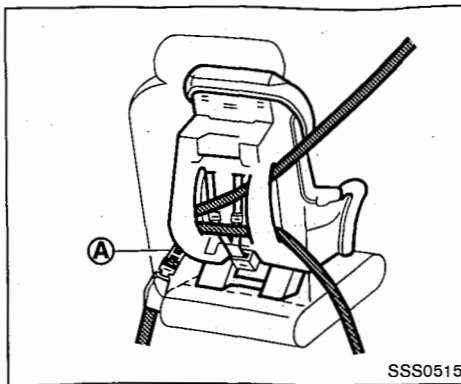

4. Route the seat belt tongue through the child restraint system and insert it into the buckle until you hear and feel the latch engage.

To prevent slack in the lap belt, it is necessary to secure the shoulder belt in place with a locking clip (A). Use the locking clip or another locking device attached to the child restraint system.

Be sure to follow the child restraint system manufacturer's instructions for belt routing.

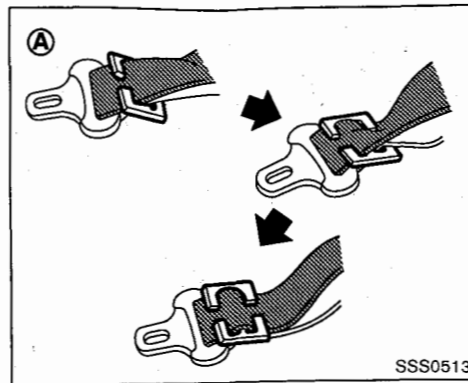

5. Slide the seat forward so that the seat belt fully tightens the child restraint system.
6. Test the child restraint system before you place the child in it. Tilt it from side to side. Try to tug it forward and check if it is held securely in place.
7. Make sure that the child restraint system is properly secured prior to each use.

Installation on front seat - without front passenger air bag

#### ! WARNING:

- NISSAN recommends that a child restraint system be installed on the rear seat. However, if you must install a child restraint system in the front passenger's seat, move the passenger's seat to the rearmost position.
- Do not install a child restraint system in the center position of the front bench seat. This position is not suitable for the installation of a child restraint system.

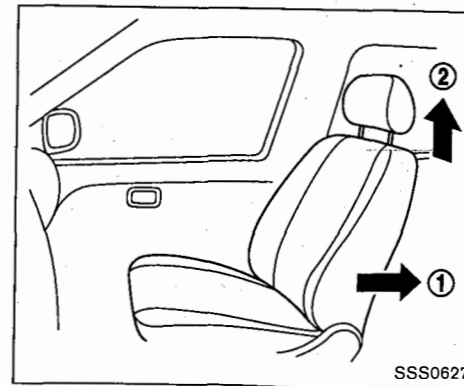

#### Rear-facing:

If you must install a rear-facing child restraint system on the front seat, follow these steps:

1. Move the seat to the rearmost position ①.
2. Adjust the head restraint to its highest position ②.
3. Position the rear-facing child restraint system on the front passenger's seat.

Always follow the child restraint system manufacturer's instructions for installation and use.

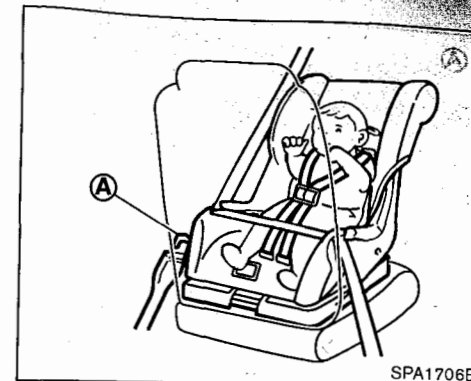

4. Route the seat belt tongue through the child restraint system and insert it into the buckle until you hear and feel the latch engage.

To prevent slack in the lap belt, it is necessary to secure the shoulder belt in place with a locking clip (A). Use the locking clip or another locking device attached to the child restraint system.

Be sure to follow the child restraint system manufacturer's instructions for belt routing.

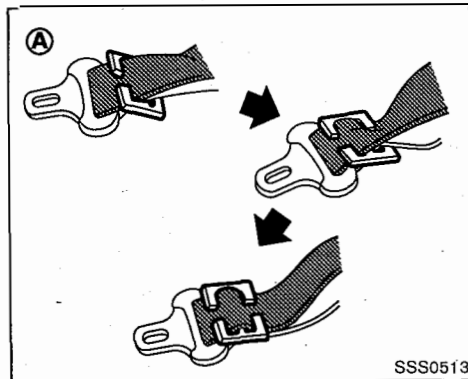

5. Slide the seat forward so that the seat belt fully tightens the child restraint system.
6. Test the child restraint system before you place the child in it. Tilt it from side to side. Try to tug it forward and check if it is held securely in place.
7. Make sure that the child restraint system is properly secured prior to each use.

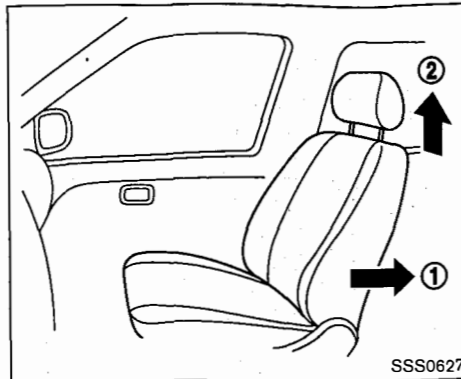

#### Front-facing:

If you must install a front-facing child restraint system on the front seat, follow these steps:

1. Move the seat to the rearmost position ①.
2. Adjust the head restraint to its highest position ②.
3. Position the front-facing child restraint system on the front passenger's seat. It should be placed in the front-facing direction only.

Always follow the child restraint system manufacturer's instructions for installation and use.

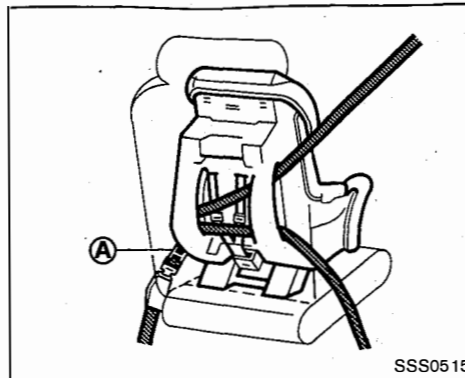

4. Route the seat belt tongue through the child restraint system and insert it into the buckle until you hear and feel the latch engage.

To prevent slack in the lap belt, it is necessary to secure the shoulder belt in place with a locking clip (A). Use the locking clip or another locking device attached to the child restraint system.

Be sure to follow the child restraint system manufacturer's instructions for belt routing.

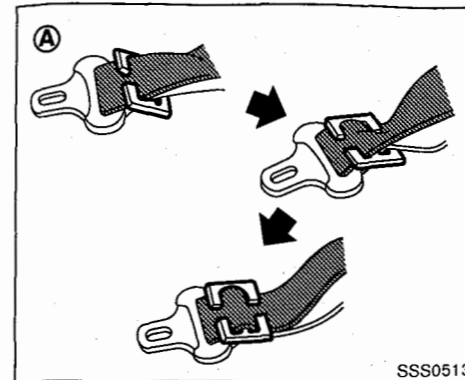

5. Slide the seat forward so that the seat belt fully tightens the child restraint system.
6. Test the child restraint system before you place the child in it. Tilt it from side to side. Try to tug it forward and check if it is held securely in place.
7. Make sure that the child restraint system is properly secured prior to each use.

#### CHILD RESTRAINT ANCHORAGE (Wagon model for Australia)

Your vehicle is designed to accommodate child restraints on the rear seat. When installing a child restraint, carefully read and follow the instructions in this manual and those supplied with the child restraint.

#### ⚠ WARNING:

- Child restraint anchorages are designed to withstand only those loads imposed by correctly fitted child restraints. Under no circumstances are they to be used for adult seat belts, harnesses or for attaching other items or equipment to the vehicle.
- The child restraint top tether strap may be damaged by contact with the tonneau cover or items in the luggage area. Remove the tonneau cover from the vehicle or secure it in the luggage area. Also secure any items in the luggage area. Your child could be seriously injured or killed in a collision if the top tether strap is damaged.

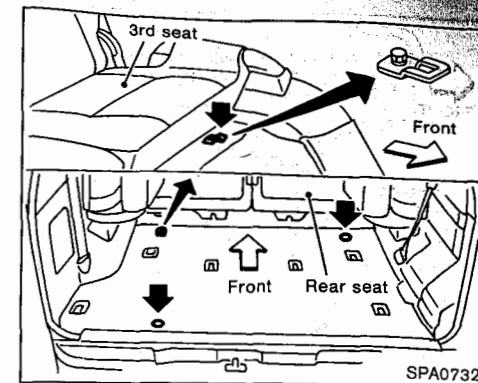

#### Anchorage location

Anchorage are located on the rear floor panel.

A child restraint anchor fitting is installed in your vehicle as shown in the illustration.

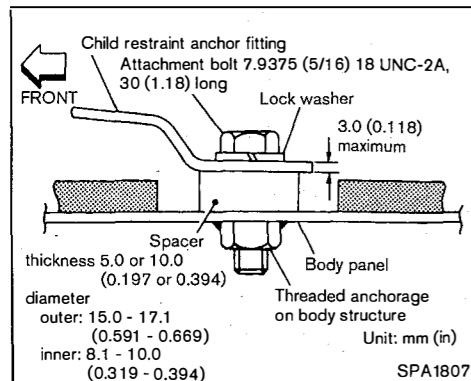

### Installation of child restraint anchorage fittings

Position the spacer and child restraint anchorage fitting as illustrated and tighten the bolt securely with a proper hand tool.

- Use a bolt of 7.9375 mm (5/16 in) in diameter 18 UNC-2A and 30 mm (1.18 in) long.
- Do not install child restraints with an anchorage fitting material thickness more than 3.0 mm (0.118 in).
- Use a lock washer with a thickness of 2.21 mm (0.0870 in) maximum.

### WARNING:

The use of a child restraint anchorage fitting more than 3.0 mm (0.118 in) thick, or bolts or spacers other than those referred to above, could seriously affect the performance of the anchorage in a collision.

### SUPPLEMENTAL RESTRAINT SYSTEM (if so equipped)

#### FRONT AND SIDE (if so equipped) AIR BAG SYSTEM

This supplemental restraint system (SRS) section contains important information concerning the driver and passenger supplemental front air bags, side air bags (if so equipped) and pretensioner seat belt.

**Supplemental front air bag system:** This system can help cushion the impact force to the head and chest of the driver and front passenger in certain frontal collisions.

**Supplemental side air bag system (if so equipped):** This system can help cushion the impact force to the head and the chest area of the driver and front passenger in certain side impact collisions. The side air bag is designed to inflate on the side where the vehicle is impacted.

These supplemental restraint systems are designed to **supplement** the crash protection provided by the driver and front passenger seat belts and are **not a substitute** for them. Seat belts should always be correctly worn and the driver and front passenger seated a suitable distance away from the steering wheel, instrument panel and front door finishers. (See "Seat belts" earlier in this section for instructions and precautions on seat belt usage.)

**When the ignition switch is turned to the ON position, the supplemental restraint**

system (SRS) air bag warning light illuminates for about 7 seconds and then turns off. This indicates that the SRS air bag system is operational.

### WARNING:

#### Supplemental front air bags:

- The supplemental front air bags ordinarily will not inflate in the event of a side impact, rear impact, roll over, or lower severity frontal collision. Always wear your seat belts to help reduce the risk or severity of injury in various kinds of accidents.
- The seat belts and the supplemental front air bags are most effective when you are sitting back and upright in the seat. Air bags inflate with great force. If you are unrestrained, leaning forward, sitting sideways or out of position in any way, you are at greater risk of injury or death in a crash and may also receive serious or fatal injuries from the supplemental front air bag if you are up against it when it inflates.

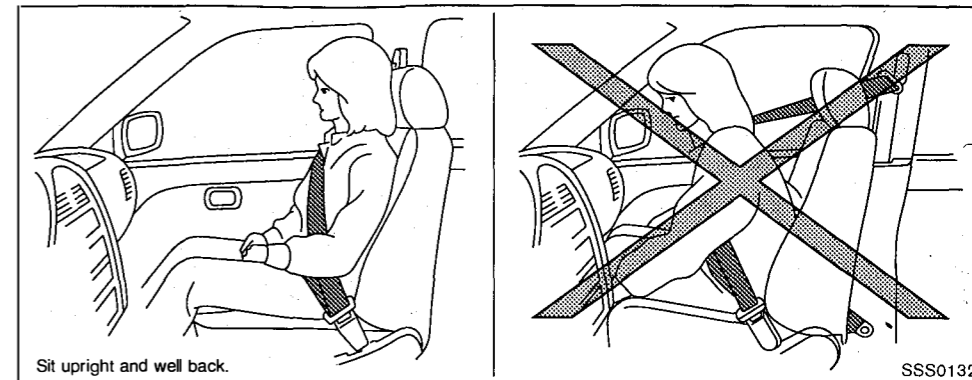
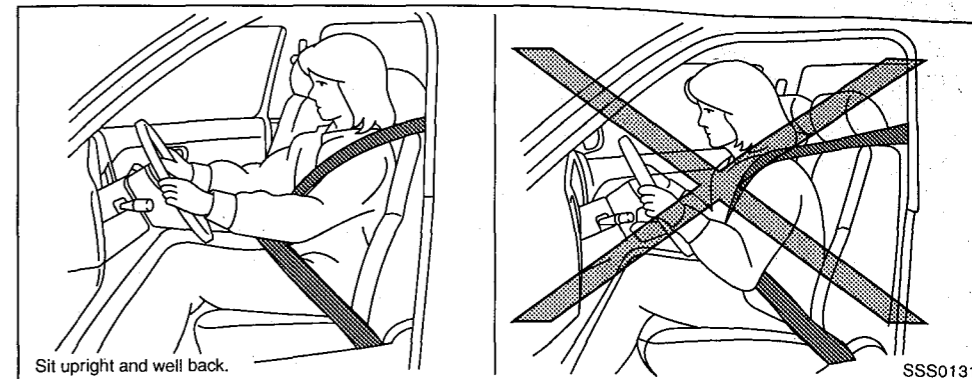

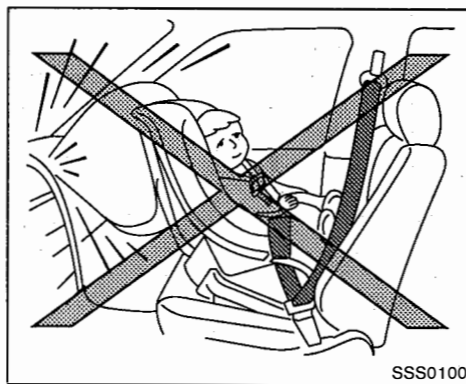
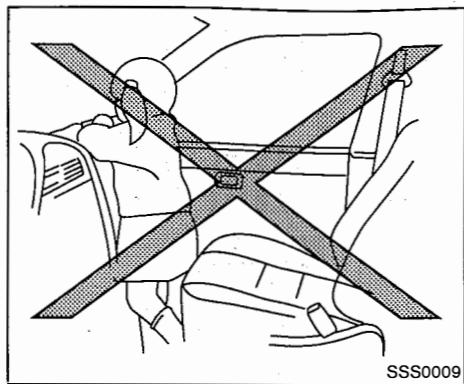
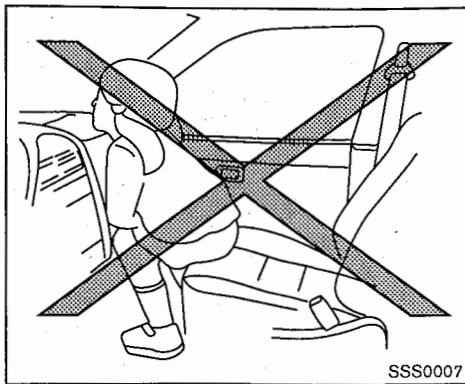
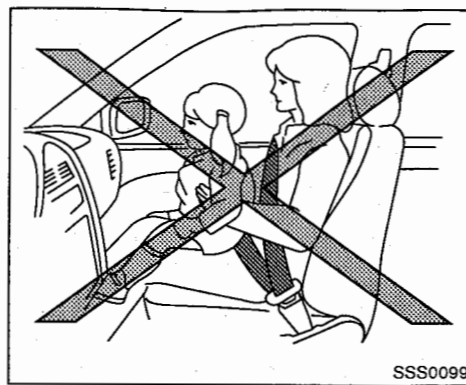
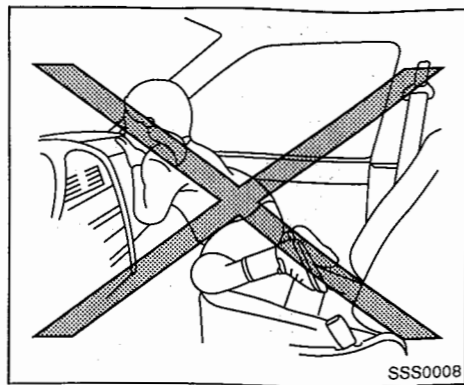
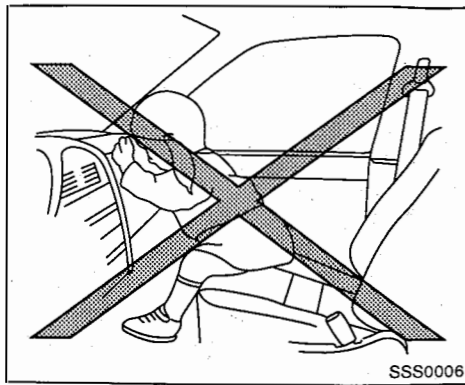

**WARNING:**

Never let children ride unrestrained as shown in the previous illustrations.

Children may be severely injured or killed when the front air bag inflates if they are not properly restrained.

Also, never install a rear facing child restraint in the front seat. For additional information, see "Child restraints" earlier in this section.

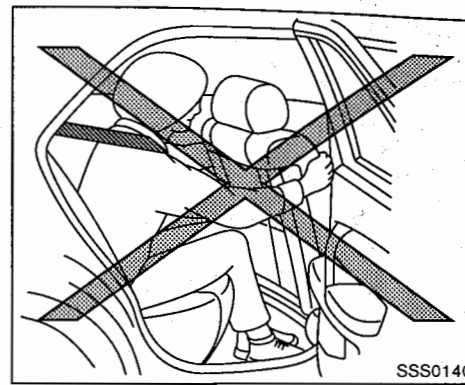
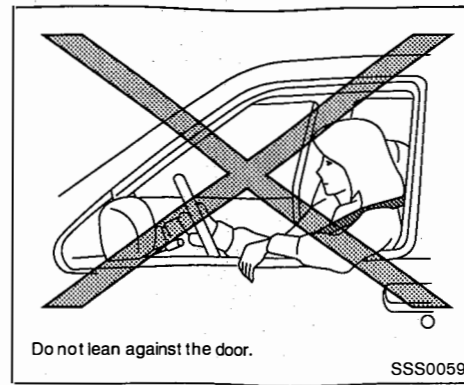

**WARNING:**

Supplemental side air bags (if so equipped):

- The supplemental side air bag ordinarily will not inflate in the event of a frontal impact, rear impact or lower severity side collision. Always wear your seat belts to help reduce the risk or severity of injury in various kinds of accidents.
- The seat belts and the supplemental side air bag are most effective when you are sitting well back and upright in the seat. The side air bag inflates with great force. Do not allow anyone to place their hand, leg or face near the side air bag

on the side of the seatback of the front seat. Do not allow anyone sitting in the front seat to extend their hand out of the window or lean against the door. Some examples of dangerous riding positions are shown in the previous illustrations.

- When sitting in the rear seat, do not hold onto the seatback of the front seat. If the side air bag inflates, the occupant may be seriously injured. Be especially careful with children, who should always be properly restrained.
- Do not use seat covers on the front seatbacks. They may interfere with supplemental side air bag inflation.



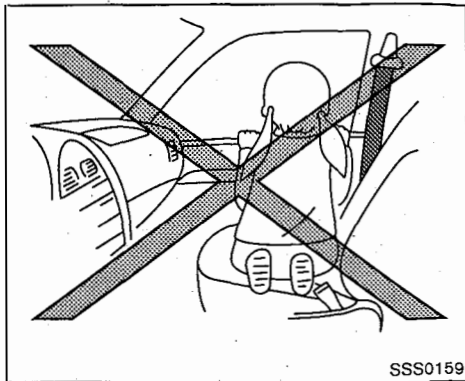

SSS0159

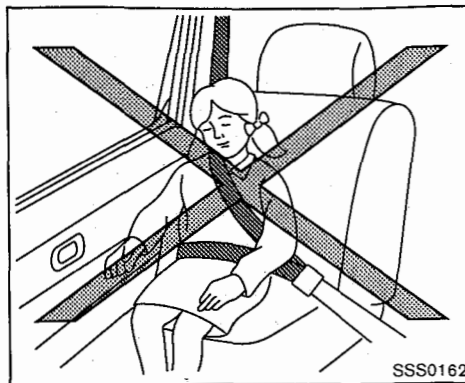

SSS0162

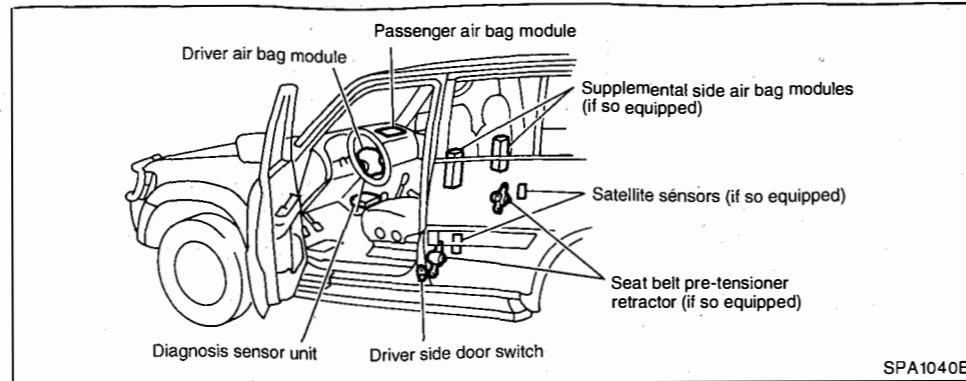

SPA1040B

**Front air bag equipped models:** The driver supplemental air bag is located in the center of the steering wheel; the front passenger supplemental air bag is mounted in the dashboard above the glove box. The air bags are designed to inflate in higher severity frontal collisions, although they may inflate if the forces in another type of collision are similar to those of a higher severity frontal impact. They may not inflate in certain frontal collisions. Vehicle damage (or lack of it) is not always an indication of proper supplemental air bag operation.

**Side air bag equipped models (if so equipped):** The side air bags are located in the outside of the seatback of the front seats. The side air bag (on the driver or front passenger

seat) is designed to inflate in higher severity side collisions, although it may inflate if the forces in another type of collision are similar to those of a higher severity side impact. It is designed to inflate on the side where the vehicle is impacted. It may not inflate in certain side collisions. Vehicle damage (or lack of it) is not always an indication of proper side air bag operation.

When the supplemental front air bag or side air bag inflates, a fairly loud noise may be heard, followed by release of smoke. This smoke is not harmful and does not indicate a fire, but care should be taken not to inhale it, as it may cause irritation and choking. Those with a history of breathing trouble should get fresh air promptly.

Supplemental front air bags and side air bags,

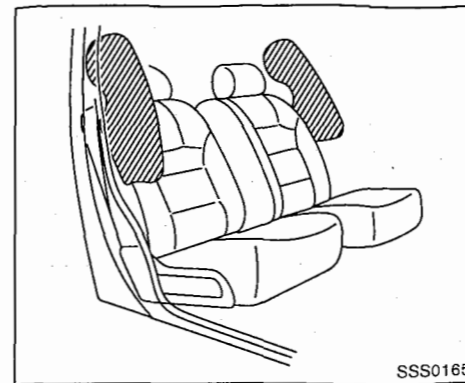

SSS0165

along with the use of seat belts, help to cushion the impact force on the head and chest of the front occupants. They can help save lives and reduce serious injuries. However, an inflating air bag may cause facial abrasions or other injuries.

Air bags and side air bags do not provide restraint to the lower body.

The seat belts should be correctly worn and the driver and passenger seated upright as far as practical away from the steering wheel or dashboard. Since the air bags and side air bag inflate quickly in order to help protect the front occupants, the force of the air bag or side air bag inflating can increase the risk of injury if the occupant is too close to or is against the air bag module or side air bag module during inflation.

The air bag or side air bag will deflate quickly after the collision is over.

When the ignition switch is turned to the ON position, the supplemental restraint system (SRS) air bag warning light illuminates for about 7 seconds and then turns off. This indicates that the SRS air bag system is operational.

**WARNING:**

- Right after inflation, several air bag system components will be hot. Do not touch them; you may severely burn yourself.
- No unauthorized changes should be made to any components or wiring of the supplemental front air bag or side air bag system. This is to prevent accidental inflation of the air bag or side air bag or damage to the air bag system.
- Tampering with these systems may result in serious personal injury. Tampering includes changes to the steering wheel and the instrument panel, and the front seats assembly by placing material over the steering wheel pad and above the dashboard and near the seatback of the front seat or by installing additional trim material around these systems.

- Do not attach any objects to the steering wheel pad and to the instrument panel. Objects attached to the steering wheel pad and to the instrument panel may become dangerous projectiles and cause injury if the air bag inflates.

- Work around and on the supplemental front air bag systems or side supplemental front air bag system should be done by a NISSAN dealer. Installation of electrical equipment should also be done by a NISSAN dealer. The SRS wiring harnesses\* should not be modified or disconnected. Unauthorized electrical test equipment and probing devices should not be used on the air bag systems.

\* The SRS wiring harness connectors are yellow and/or orange for easy identification.

Pre-tensioner seat belt system (if so equipped for front seats)

**WARNING:**

- The pre-tensioner seat belt cannot be reused after activation. It must be replaced together with the retractor as a unit.
- If the vehicle becomes involved in cer-

tain types of frontal collision but the pre-tensioner is not activated, be sure to have the pre-tensioner seat belt system checked and, if necessary, replaced by a NISSAN dealer.

- No unauthorized changes should be made to any components or wiring of the pre-tensioner seat belt system. This is to prevent accidental retraction or extension of the pre-tensioner seat belt or damage to the pre-tensioner seat belt operation. Tampering with the pre-tensioner seat belt system may result in serious personal injury.
- Work around and on the pre-tensioner seat belt system should be done by a NISSAN dealer. Installation of electrical equipment should also be done by a NISSAN dealer. Unauthorized electrical test equipment and probing devices should not be used on the pre-tensioner seat belt system.
- If you need to dispose of the pre-tensioner or scrap the vehicle, contact a NISSAN dealer. Correct pre-tensioner disposal procedures are set forth in the appropriate NISSAN Service Manual. Incorrect disposal procedures could cause personal injury.

The front seat pre-tensioner seat belt system activates in conjunction with the air bag. Working with the seat belt retractor, it helps tighten the seat belt the instant the vehicle becomes involved in certain types of collisions, thereby restraining seat occupants.

The pre-tensioner is encased with the seat belt's retractor. These seat belts are used the same as conventional seat belts.

When the pre-tensioner seat belt activates, smoke is released and a loud noise may be heard. The smoke is not harmful, but care should be taken not to inhale it as it may cause irritation and choking.

If any abnormality occurs in the pre-tensioner system, the SRS air bag warning light  will not come on, will flash intermittently or will turn on for 7 seconds and remain on after the ignition key has been turned to the ON or START position. In this case, the pre-tensioner seat belt may not function properly.

When selling your vehicle, we request that you inform the buyer about the pre-tensioner seat belt system and guide the buyer to the appropriate sections in this Owner's Manual.

## DRIVER AIR BAG SYSTEM

This Supplemental Restraint System section contains important information concerning the driver air bag and pre-tensioner seat belt. The Supplemental Restraint System Air Bag can help reduce impact force to the driver in certain frontal collisions. The air bag is designed to **supplement** the crash protection provided by the driver seat belt and is **not a substitute** for it. The seat belts should always be correctly worn and the driver seated a suitable distance from the steering wheel. (See "Seat belts" earlier in this section for instructions and precautions on seat belt usage.)

**When the ignition switch is turned to the ON position, the supplemental restraint system (SRS) air bag warning light illuminates for about 7 seconds and then turns off. This indicates that the SRS air bag system is operational.**

### WARNING:

- The air bag ordinarily will not inflate in the event of a side impact, rear impact, roll over, or lower severity frontal collision; so always wear your seat belts to help reduce the risk or severity of injury in various kinds of accidents.
- The seat belts and the air bag are most

effective when you are sitting back and upright in the seat. Air bag inflates with great force. If you are unrestrained, leaning forward, sitting sideways or out of position in any way, you are at greater risk of injury or death in a crash and may also receive serious or fatal injuries from the air bag if you are up against it when it inflates.

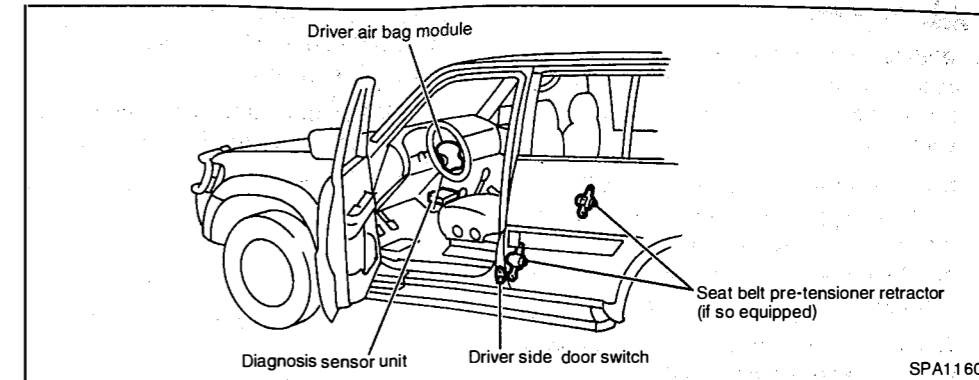

SPA1160

## Air bag system

The driver air bag is located in the center of the steering wheel. The air bag system is designed to inflate in higher severity frontal collisions, although it may inflate if the forces in another type of collision are similar to those of a higher severity frontal impact. When the air bag inflates, a fairly loud noise may be heard, followed by release of smoke. This smoke is not harmful and does not indicate a fire, but care should be taken not to intentionally inhale it, as it may cause irritation and choking. The air bag, along with the use of seat belts, helps to cushion the impact force on the head and chest of the occupant.

The seat belts should be correctly worn and the

driver seated upright as far as practical away from the steering wheel. Since the air bag inflates quickly in order to help protect the occupant, the force of the air bag inflating can increase the risk of injury if the occupant is too close to or is against the air bag module during inflation. The air bag will deflate quickly after a collision.

**When the ignition switch is turned to the ON position, the supplemental restraint system (SRS) air bag warning light illuminates for about 7 seconds and then turns off. This indicates that the SRS air bag system is operational.**

**! WARNING:**

- Right after inflation, several air bag system components will be hot. Do not touch them; you may severely burn yourself.
- No unauthorized changes should be made to any components or wiring of the air bag system. This is to prevent accidental inflation of the air bag or damage to the air bag system.
- Tampering with the air bag system may result in serious personal injury. Tampering includes changes to the steering wheel by placing material over the steering wheel pad or by installing additional trim material around the air bag system.
- Do not attach any objects to the steering wheel pad. Objects attached to the steering wheel pad may become dangerous projectiles and cause injury if the air bag inflates.
- Work around and on the air bag system should be done by a NISSAN dealer. Installation of electrical equipment should also be done by a NISSAN dealer. The SRS wiring harnesses\* should not be modified or disconnected.

Unauthorized electrical test equipment and probing devices should not be used on the air bag system.

- \* The SRS wiring harness connectors are yellow and/or orange for easy identification.



#### AIR BAG WARNING LABELS

Warning labels about the air bag system are placed in the vehicle.

**Child restraint on front passenger seat (front passenger air bag equipped model)**

If your vehicle is equipped with a passenger air bag, you will find an air bag warning label attached to the passenger side of the instrument panel.

This label warns you not to fit a rear-facing child restraint on the front passenger seat as such a restraint system used in this position could cause serious injury to the infant in case of air

bag deployment during a collision.

In vehicles equipped with a passenger air bag system, use rear-facing child restraints only on the rear seats. When installing child restraints in your vehicle, always carefully observe the manufacturer's instructions.

For more details on the installation of child restraints, see also "Child restraints" earlier in this section.

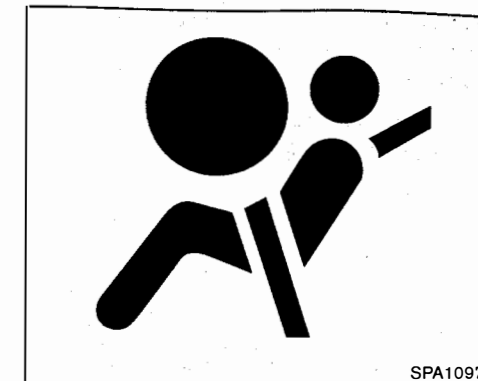

#### AIR BAG WARNING LIGHT

The supplemental restraint system (SRS) air bag warning light, displayed in the instrument panel, monitors the circuits of the front and side (if so equipped) air bag systems and pre-tensioner seat belt (if so equipped). The circuits monitored by the SRS air bag warning light are all sensors, air bag modules and all related wiring and pre-tensioner seat belt.

After turning the ignition switch to the ON position, the SRS air bag warning light will illuminate. The SRS air bag warning light will turn off after about 7 seconds if the system is operational.

If any of the following conditions occurs, the

front air bag and side air bag systems and pre-tensioner seat belt need servicing and should be taken to a NISSAN dealer:

- The SRS air bag warning light remains on after approximately 7 seconds.
- The SRS air bag warning light flashes intermittently.
- The SRS air bag warning light does not come on at all.

Under these conditions, the front air bags, side air bags and/or pre-tensioner seat belt will not operate properly. It must be checked and repaired.

#### Repair and replacement procedure

The front air bags, side air bags and pre-tensioner seat belt are designed to inflate on a one-time-only basis. As a reminder, unless it is damaged, the air bag warning light will remain illuminated after inflation has occurred. Repair and replacement of the air bag system should be done only by a NISSAN dealer.

When maintenance work is required on the vehicle, the air bag systems and related parts and pre-tensioner seat belt should be pointed out to the person conducting the maintenance. The ignition switch should always be in the

LOCK position when working under the hood or inside the vehicle.

#### WARNING:

- **Once the air bag has been inflated, the air bag module will not function and must be replaced. The air bag module must be replaced by a NISSAN dealer. The inflated air bag module cannot be repaired.**
- **The air bag systems should be inspected by a NISSAN dealer if there is any damage to the front end portion of the vehicle.**
- **When selling your vehicle, we request that you inform the buyer about the air bag system and guide the buyer to the appropriate sections in this Owner's Manual.**
- **If you need to dispose of an air bag or scrap the vehicle, contact a NISSAN dealer. Correct air bag disposal procedures are set forth in the appropriate NISSAN Service Manual. Incorrect disposal procedures could cause personal injury.**

## 2 Instruments and controls

Instrument panel .....	2-2	Front fog lights .....	2-29
Wagon and hardtop models .....	2-2	Rear fog light .....	2-30
Pickup models .....	2-6	Hazard warning flasher switch .....	2-31
Meters and gauges .....	2-8	Horn .....	2-31
Speedometer and odometer .....	2-8	Sub fuel tank transfer switch .....	2-31
Tachometer .....	2-9	Rear differential lock-up switch .....	2-32
Engine coolant temperature gauge .....	2-10	Rear stabilizer release switch .....	2-33
Fuel gauge .....	2-11	Heated seats .....	2-33
Instrument brightness control .....	2-12	Clock .....	2-34
Outside temperature display and compass .....	2-13	Adjusting the time .....	2-35
Outside temperature display .....	2-13	Resetting the time (for audio display model) .....	2-36
Compass display .....	2-15	Ashtrays and cigarette lighter .....	2-37
Warning/indicator lights and audible reminders .....	2-16	Power outlet .....	2-38
Checking bulbs .....	2-16	Storage .....	2-38
Warning lights .....	2-16	Glove box .....	2-39
Indicator lights .....	2-19	Console box .....	2-39
Audible reminders .....	2-21	Instrument center box .....	2-39
Wiper and washer switch .....	2-22	Card holder .....	2-40
Windshield wiper and washer switch .....	2-22	Seatback tray .....	2-40
Rear window wiper and washer switch .....	2-23	Sunglasses holder .....	2-41
Defogger switch .....	2-24	Cup holders .....	2-42
Windshield deicer switch .....	2-25	Windows .....	2-43
Headlight and turn signal switch .....	2-25	Manual windows .....	2-43
Xenon headlights .....	2-25	Power windows .....	2-44
Headlight switch .....	2-27	Sunroof .....	2-46
Turn signal switch .....	2-27	Interior lights .....	2-47
Headlight aiming control switch .....	2-27	Room light .....	2-47
Headlight cleaner switch .....	2-29	Personal light .....	2-48
Fog light switch .....	2-29	Vanity mirror light .....	2-49

## INSTRUMENT PANEL

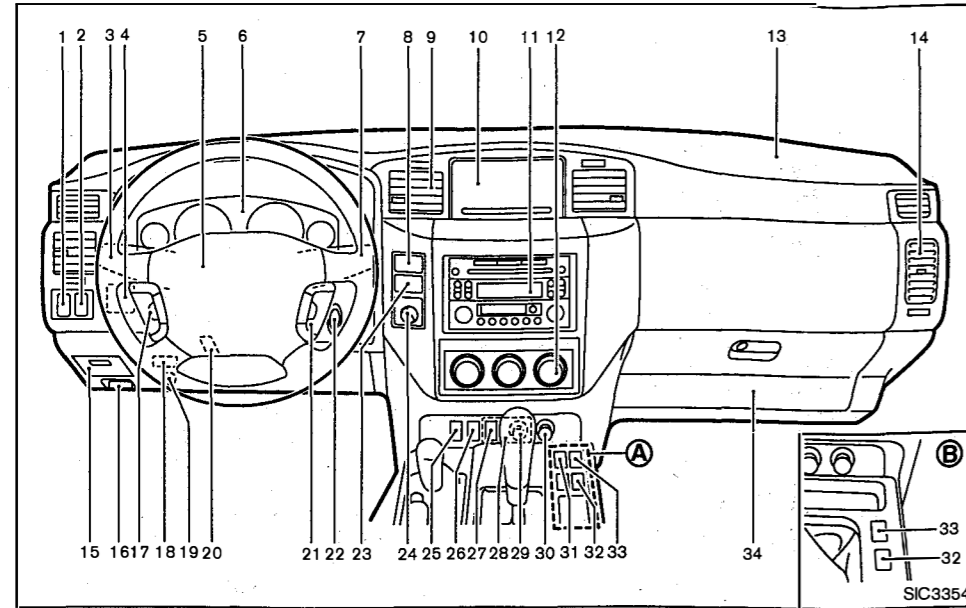

### WAGON AND HARDTOP MODELS

#### Left-hand drive (LHD) models

1. Heat switch (for ZD engine) (P.4-12)
2. Instrument brightness control switch\* (P.2-12)
3. Headlight and turn signal switch (P.2-25)/ Fog light switch\* (P.2-29)
4. Outside mirror remote control switch\* (P.3-26)
5. Horn (P.2-31)/Driver air bag\* (P.1-38)
6. Meters/gauges (P.2-8)/Clock (P.2-34)
7. Wiper and washer switch (P.2-22)
8. Hazard warning flasher switch (P.2-31)
9. Center ventilator (P.4-5)
10. Instrument center box (P.2-39) or Navigation system display (P.4-2)\*1

11. Audio system\* (P.4-15)/Clock\* (P.2-34)
12. Heater/air conditioner control\* (P.4-6)
13. Passenger air bag\* (P.1-38)
14. Side ventilator (P.4-5)
15. Fuse box cover (P.8-37)
16. Hood release handle (P.3-15)
17. Audio control steering switch\* (P.4-51)
18. Fuel filler lid opener (P.3-15)
19. Throttle control knob (for TD engine) (P.5-9)
20. Tilting steering wheel lock lever (P.3-24)
21. Cruise control main/set switch\* (P.5-27)
22. Ignition switch/steering lock (P.5-5)
23. Rear window defogger switch\* (P.2-24)/ Windshield deicer switch\* (P.2-25)
24. Rear differential lock-up switch\* (P.2-32)
25. Rear heater fan control switch\* (P.4-13) or Cool box switch\* (P.4-14)
26. Rear cooler switch\* (P.4-13)
27. Sub fuel tank transfer switch\* (P.2-31)
28. Ashtray\* (P.2-37)
29. Cigarette lighter (P.2-37)
30. Power outlet\* (P.2-38) or Cigarette lighter (P.2-37)
31. Automatic transmission mode switch\* (P.5-14, P.5-17)
32. Headlight cleaner switch\* (P.2-29)
33. Headlight aiming control switch\* (P.2-27)
34. Glove box (P.2-38)

\*: if so equipped

\*1: Refer to the separately provided Navigation System Owner's Manual (if so equipped).

**See the page indicated in parentheses for operating details.**

(A): Automatic transmission model

(B): Manual transmission model

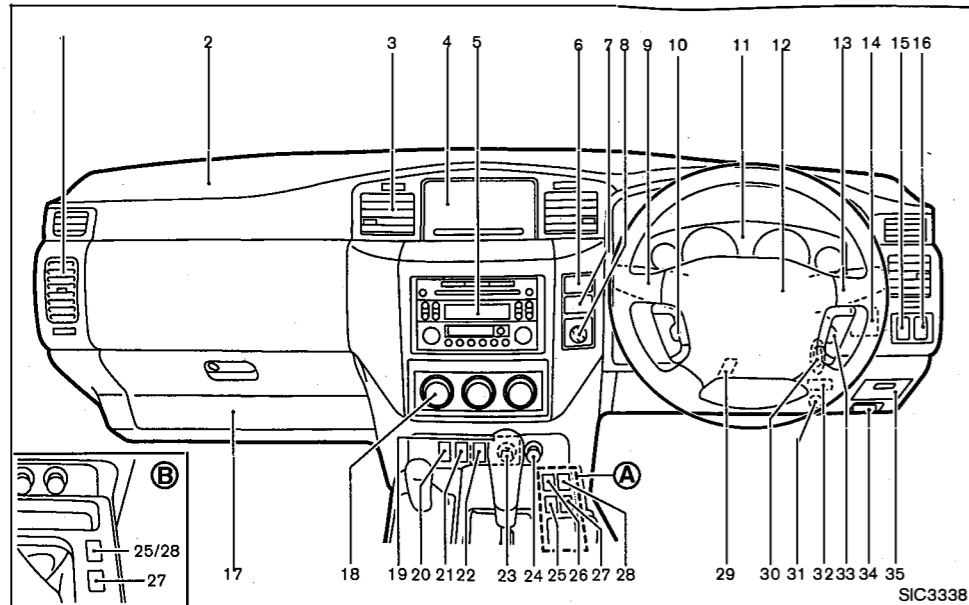

#### Right-hand drive (RHD) models

1. Side ventilator (P.4-5)
2. Passenger air bag\* (P.1-38)
3. Center ventilator (P.4-5)
4. Instrument center box (P.2-39) or Navigation system display (P.4-2)\*1
5. Audio system\* (P.4-15)/Clock\* (P.2-34)
6. Hazard warning flasher switch (P.2-31)

7. Rear window defogger switch\* (P.2-24)/Windshield deicer switch\* (P.2-25)
8. Rear differential lock-up switch\* (P.2-32)
9. Wiper and washer switch (P.2-22) or Headlight and turn signal switch (P.2-25)/Fog light switch\* (P.2-29)
10. Audio control steering switch\* (P.4-51)
11. Meters/gauges (P.2-8)/Clock (P.2-34)
12. Horn (P.2-31)/Driver air bag\* (P.1-38)

13. Headlight and turn signal switch (P.2-25)/Fog light switch\* (P.2-29) or Wiper and washer switch (P.2-22)
  14. Outside mirror remote control switch\* (P.3-26)
  15. Instrument brightness control switch\* (P.2-12)
  16. Heat switch (for ZD engine) (P.4-12)
  17. Glove box (P.2-38)
  18. Heater/air conditioner control\* (P.4-6)
  19. Ashtray\* (P.2-37)
  20. Rear heater fan control switch\* (P.4-13)
  21. Rear cooler switch\* (P.4-13)
  22. Sub fuel tank transfer switch\* (P.2-31)
  23. Cigarette lighter (P.2-37)
  24. Power outlet\* (P.2-38) or Cigarette lighter (P.2-37)
  25. Power antenna switch\* (P.4-16)
  26. Automatic transmission mode switch\* (P.5-14, P.5-17)
  27. Headlight cleaner switch\* (P.2-29)
  28. Headlight aiming control switch\* (P.2-27)
  29. Tilting steering wheel lock lever (P.3-24)
  30. Ignition switch/steering lock (P.5-5)
  31. Throttle control knob (for TD engine) (P.5-9)
  32. Fuel filler lid opener (P.3-15)
  33. Cruise control main/set switch\* (P.5-27)
  34. Hood release handle (P.3-15)
  35. Fuse box cover (P.8-37)
- \*: if so equipped

\*1: Refer to the separately provided Navigation System Owner's Manual (if so equipped).

**See the page indicated in parentheses for operating details.**

(A): Automatic transmission model

(B): Manual transmission model

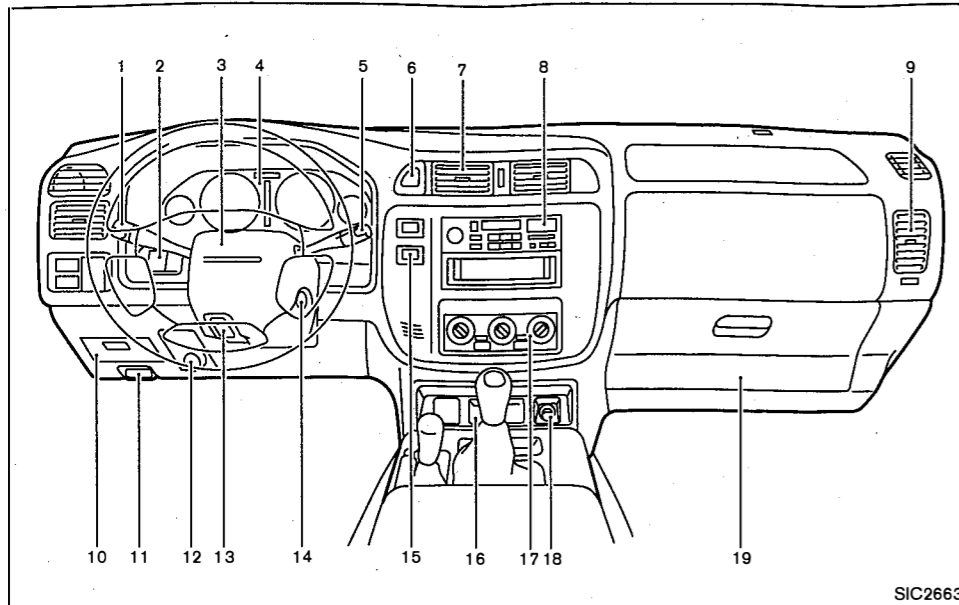

SIC2663

### PICKUP MODELS

#### Left-hand drive (LHD) models

1. Headlight and turn signal switch (P.2-25)
2. Fog light switch\* (P.2-29)
3. Horn (P.2-31)
4. Meters/gauges (P.2-8)/Clock\* (P.2-34)
5. Wiper and washer switch (P.2-22)
6. Hazard warning flasher switch (P.2-31)

7. Center ventilator (P.4-5)
8. Audio system\* (P.4-15)/Clock\* (P.2-34)
9. Side ventilator (P.4-5)
10. Fuse box cover (P.8-37)
11. Hood release handle (P.3-15)
12. Throttle control knob (for TD engine) (P.5-9)
13. Tilting steering wheel lock lever (P.3-24)

14. Ignition switch/steering lock (P.5-5)
15. Sub fuel tank transfer switch\* (P.2-31)
16. Ashtray\* (P.2-37)
17. Heater/air conditioner control\* (P.4-6)
18. Cigarette lighter (P.2-37)
19. Glove box (P.2-38)

\*: if so equipped

See the page indicated in parentheses for operating details.

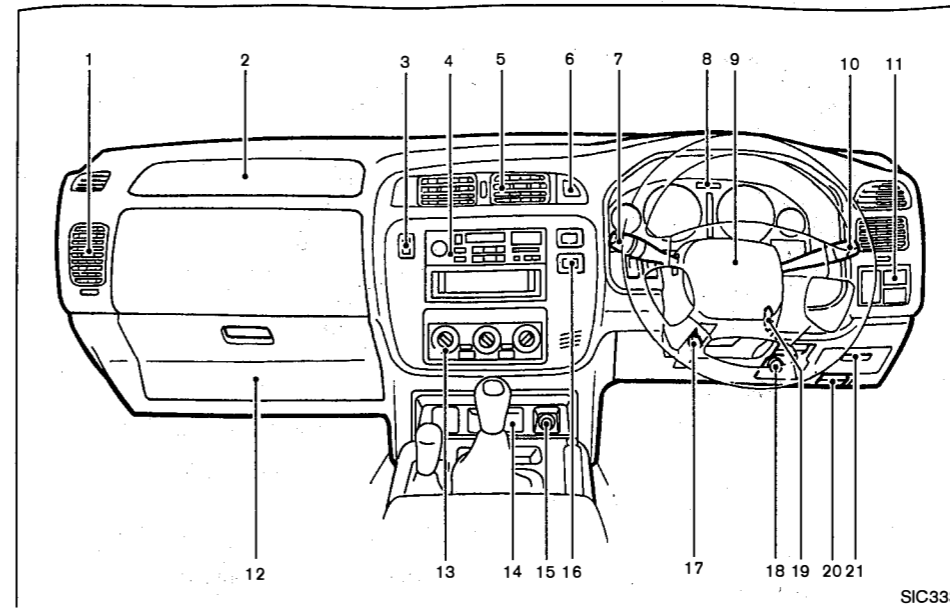

SIC3339

### Right-hand drive (RHD) models

1. Side ventilator (P.4-5)
2. Passenger air bag\* (P.1-38)
3. Power antenna switch\* (P.4-16)
4. Audio system\* (P.4-15)/Clock\* (P.2-34)
5. Center ventilator (P.4-5)
6. Hazard warning flasher switch (P.2-31)
7. Wiper and washer switch (P.2-22)

8. Meters/gauges (P.2-8)/Clock\* (P.2-34)
9. Horn (P.2-31)/Driver air bag\* (P.1-38)
10. Headlight and turn signal switch (P.2-25)
11. Fog light switch\* (P.2-29) or Heat switch (for ZD engine) (P.4-12)
12. Glove box (P.2-38)
13. Heater/air conditioner control\* (P.4-6)
14. Ashtray\* (P.2-37)
15. Cigarette lighter (P.2-37)

16. Sub fuel tank transfer switch\* (P.2-31)
17. Tilting steering wheel lock lever (P.3-24)
18. Throttle control knob (for TD engine) (P.5-9)
19. Ignition switch/steering lock (P.5-5)
20. Hood release handle (P.3-15)
21. Fuse box cover (P.8-37)

\*: if so equipped

See the page indicated in parentheses for operating details.

## METERS AND GAUGES

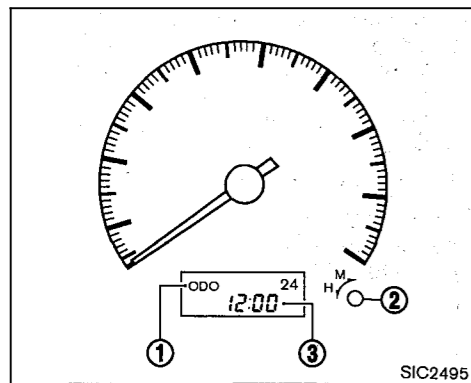

- ① Odometer/twin trip odometer  
 ② Reset knob for odometer  
 ③ Clock (if so equipped: See "Clock" later in this section.)

### SPEEDOMETER AND ODOMETER

#### Speedometer

The speedometer indicates vehicle speed (km/h or MPH). Scale resolution on the meter varies with models.

#### Odometer/Twin trip odometer

The odometer records the total distance the vehicle has been driven.

The trip odometer records the distance of individual trips.

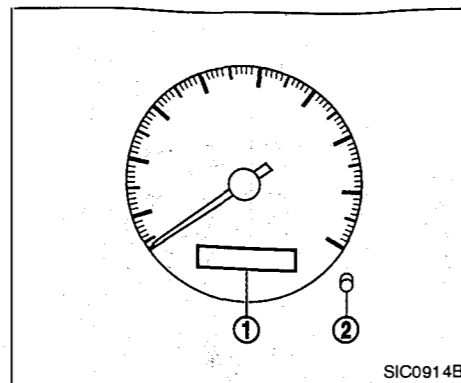

Type B

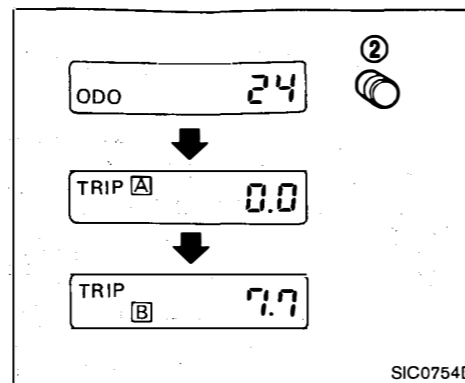

SIC0754D

#### Changing the trip odometer display:

Push the reset knob ② to change the display as follows:

ODO → TRIP A → TRIP B → ODO

#### Resetting the trip odometer:

Push the reset knob for more than 1 second to reset the trip odometer to zero.

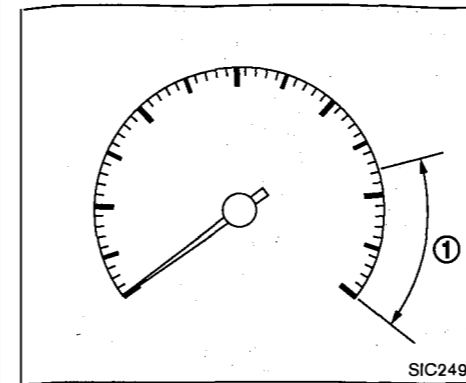

Type A

### TACHOMETER

The tachometer indicates engine speed in revolutions per minute (rpm). **Do not rev the engine into the red zone ①.**

The red zone varies with the engine type.

#### CAUTION:

**When engine speed approaches the red zone, shift to a higher gear. Operating the engine in the red zone may cause serious engine damage.**

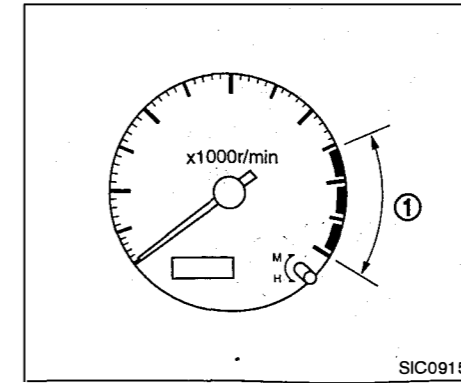

Type B



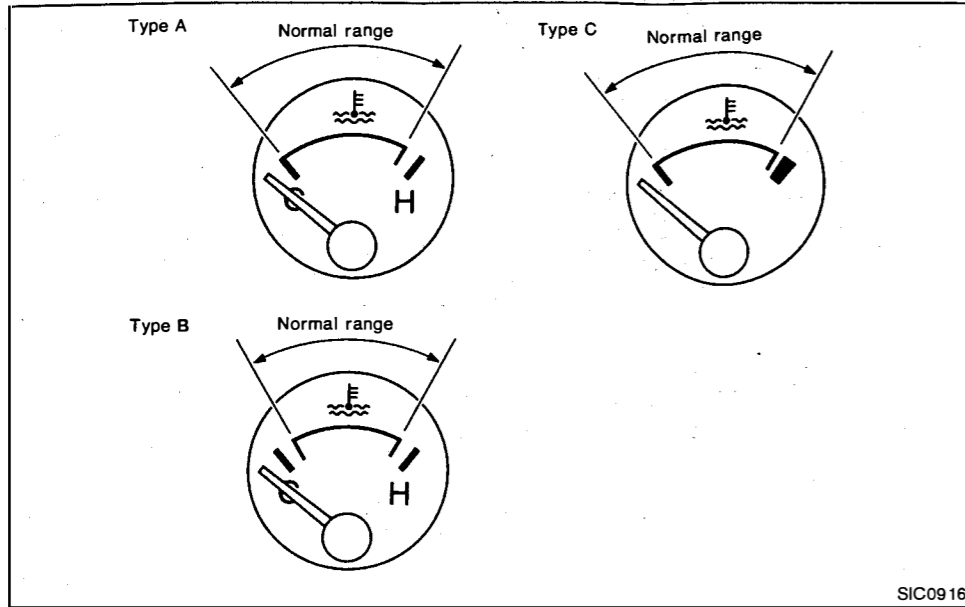

SIC0916

### ENGINE COOLANT TEMPERATURE GAUGE

The gauge indicates the engine coolant temperature.

The engine coolant temperature will vary with the outside air temperature and driving conditions.

#### CAUTION:

If the gauge indicates engine coolant temperature over the normal range, stop the vehicle as soon as safely possible. If the engine is overheated, continued operation of the vehicle may seriously damage the engine. See "If your vehicle overheats" in the "6. In case of emergency" section for immediate action required.

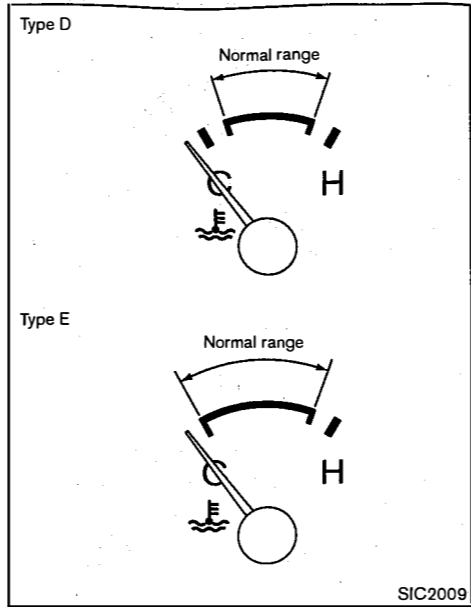

SIC2009

#### WARNING:

Allow the engine to cool before removing the radiator cap to avoid the danger of being scalded.

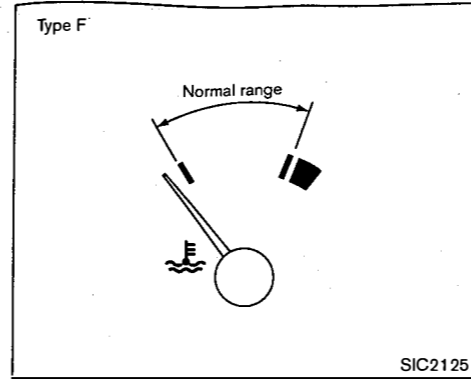

SIC2125

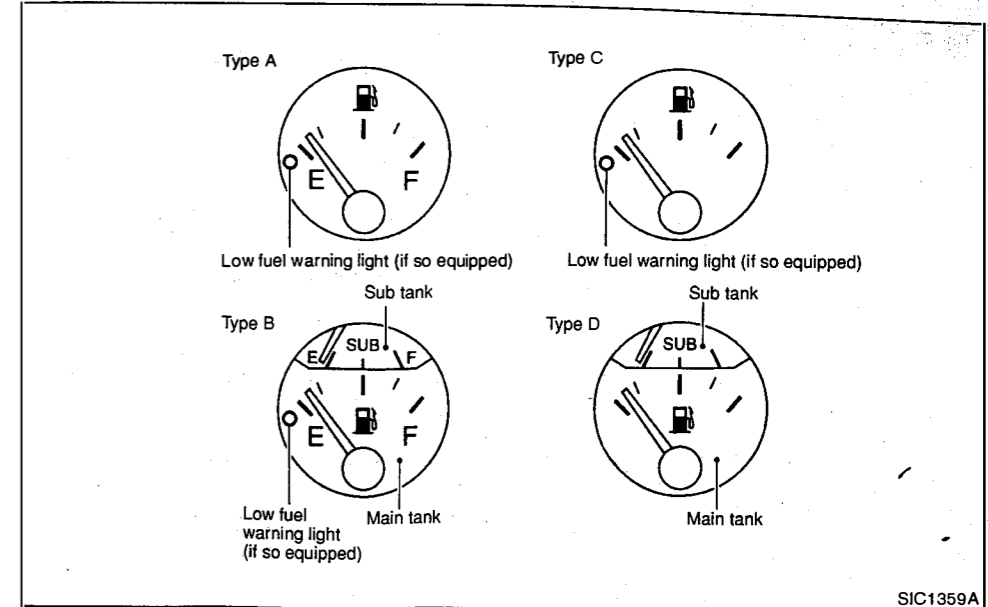

SIC1359A

### FUEL GAUGE

The gauge indicates the APPROXIMATE fuel level in the main tank and sub (if so equipped) tank.

The gauge may move slightly during braking, turning, acceleration, or going up or down hill.

#### Types A to D:

The gauge needle is designed to remain in approximately the same position, even when the ignition key is turned to the OFF position.

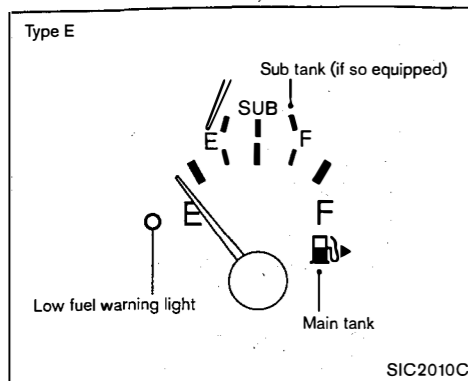

Types E and F:

The gauge needle is designed to move to the E (Empty) position when the ignition key is turned to the OFF position.

The  indicates that the fuel filler lid is located on the right side of the vehicle.

**The low fuel warning light (if so equipped) comes on when the fuel tank is getting low. Refuel as soon as it is convenient, preferably before the gauge reaches the E (empty) position. There should be a small reserve of fuel in the tank when the fuel gauge needle reaches E.**

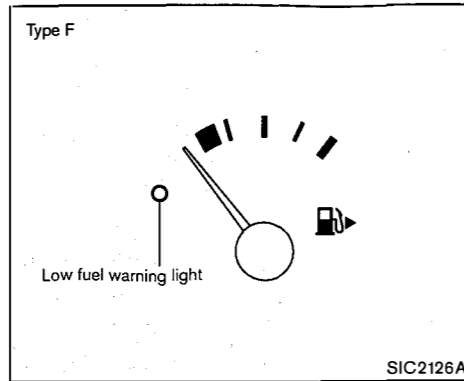

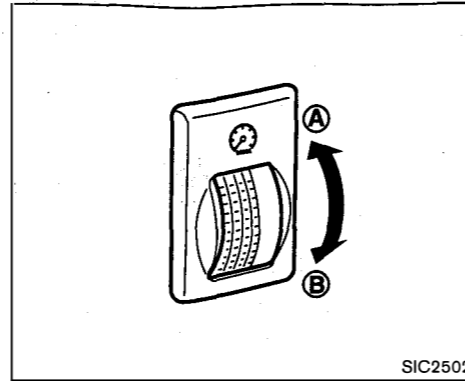

**CAUTION:**

**Refill the fuel tank before the gauge registers E.**



**INSTRUMENT BRIGHTNESS CONTROL (if so equipped)**

The instrument brightness control operates when the headlight switch is in the  or  position.

Keep turning the switch to adjust the brightness of the instrument panel lights. Turning the switch to the **A** side will brighten the lights. Turning it to the **B** side will dim the lights.

**OUTSIDE TEMPERATURE DISPLAY AND COMPASS (if so equipped)**

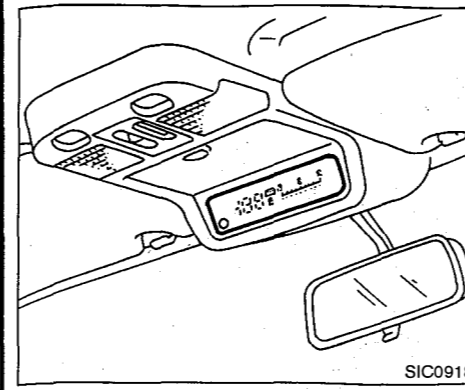

This unit is a display unit with the following functions:

- Function to measure terrestrial magnetism and indicate heading direction of vehicle
- Function to indicate outside air temperature
- Function to indicate caution for frozen road surfaces

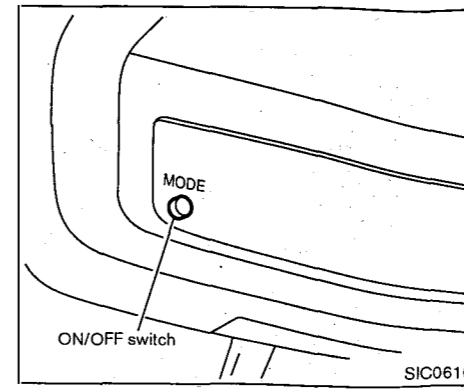

**OUTSIDE TEMPERATURE DISPLAY**

Push the ON/OFF switch when the ignition switch is in the ACC or ON position. The outside temperature will be displayed in °F.

- Push the switch again to change the indication range from °F to °C.
- If the outside temperature drops below the freezing point, the display indicates **ICE**.

- When the outside temperature is between 55°C (130°F) and 70°C (158°F), the display shows 55°C (130°F).
- When the outside temperature is lower than -30°C (-20°F) or higher than 70°C (158°F), the display shows only ... though it is operating. This is not a malfunction.
- The outside temperature sensor is located in front of the radiator. The sensor may be affected by road or engine heat, wind direction and other driving conditions. The display may differ from the actual outside temperature or the temperature displayed on various signs or billboards.

**CAUTION:**

**Use the ICE indication for reference only. Confirm the traffic information and road conditions to drive safely.**

Zone variation chart

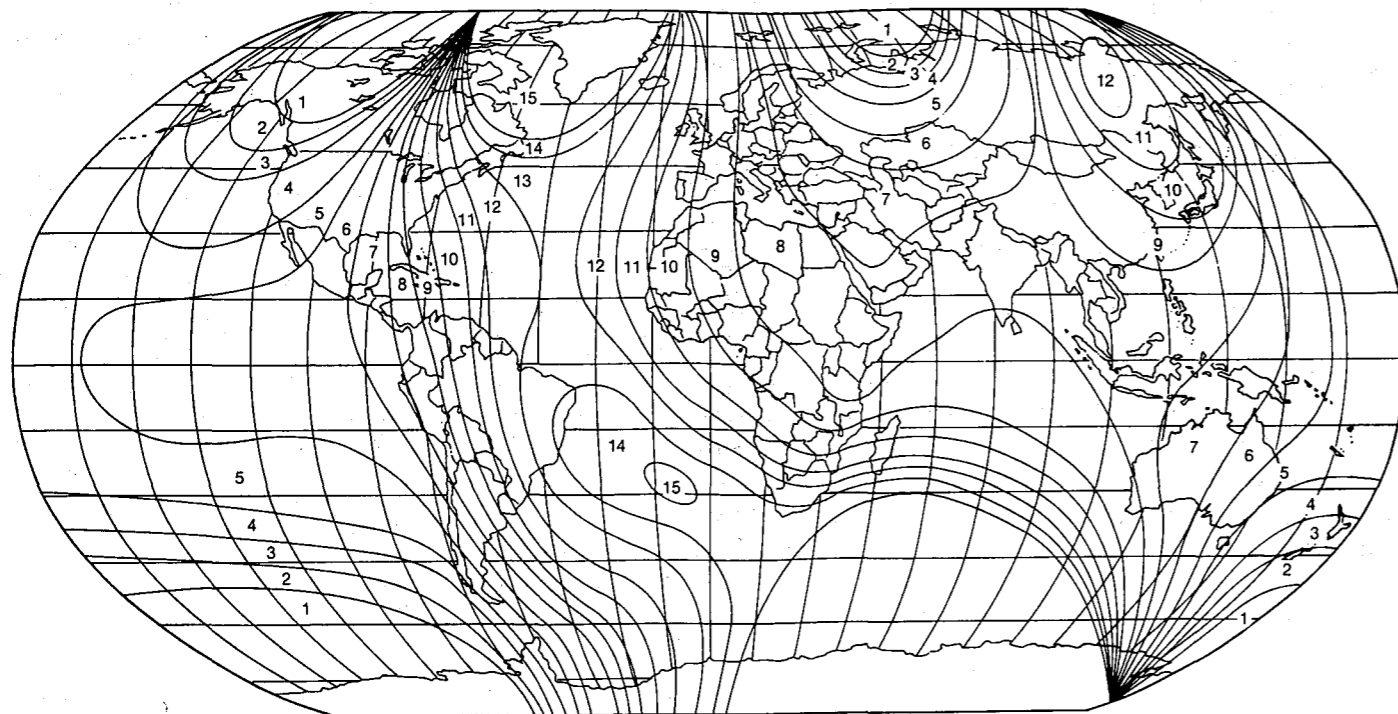

SIC0971

## COMPASS DISPLAY

Push the ON/OFF switch when the ignition switch is in the ACC or ON position. The direction will be displayed.

### Zone variation change procedure

The difference between magnetic north and geographical north is known as variance. In some areas, this difference can sometimes be great enough to cause false compass readings. Follow these instructions to set the variance for your particular location if this happens:

1. Establish your location on the zone map. Record your zone number.
2. Push in the ON/OFF switch for about 5 seconds until the current zone entry number is displayed.
3. Push the ON/OFF switch repeatedly until the new zone entry number is displayed.

Once the desired zone number is displayed, stop pushing the ON/OFF switch and the display will show compass direction within a few seconds.

- If a magnet is put close to the compass or the vehicle is driven where the terrestrial magnetism is disturbed, the compass display may not indicate the correct direction.

- In places where the terrestrial magnetism is disturbed, the correction of the direction starts automatically, extinguishing the direction bar. If turn is made one or two times, the correction is complete and the direction bar comes back on.

### Correction functions of the compass display

























The compass display is equipped with automatic correction function. If the direction is not shown correctly, carry out manual correction procedure set out below.

#### Manual correction procedure:

1. Push the ON/OFF switch for about 10 seconds. The direction bar starts blinking.
2. Drive the vehicle slowly in an open and safe area. The initial correction is completed while turning one or two turns.

In places where the terrestrial magnetism is extremely disturbed, the initial correction procedure may start automatically.

## WARNING/INDICATOR LIGHTS AND AUDIBLE REMINDERS

 or <b>ABS</b> Anti-lock Braking System (ABS) warning light*	 Seat belt warning light*	 Glow plug indicator light (diesel engine models)
 Automatic transmission check warning light (5-speed A/T models)	 Sub fuel tank warning light*	 High beam indicator light (blue)
 Automatic transmission oil temperature warning light (4-speed A/T models)	 Supplemental restraint system (SRS) air bag warning light*	 Malfunction indicator light*
 Automatic transmission park warning light (A/T models)	 Water in fuel filter warning light*	 Overdrive off indicator light (4-speed A/T models)
 Brake warning light	 Automatic transmission position indicator light (5-speed A/T models)	 Rear differential lock (DIFF-LOCK) indicator light*
 Charge warning light	 Cruise control on indicator light*	 Rear fog light indicator light*
 or  Door open warning light*	 Cruise set indicator light*	 Rear stabilizer off indicator light*
 Engine oil pressure warning light	 Four-wheel drive (4WD) mode indicator light	 Turn signal/hazard indicator lights

\*: if so equipped

### CHECKING BULBS

Apply the parking brake and turn the ignition switch to ON without starting the engine. The following lights will come on:

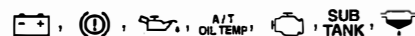

The following lights come on briefly and then go off:



If any light fails to come on, it may indicate a burned-out bulb or an open circuit in the elec-

trical system. Have the system checked, and if necessary repaired, by a NISSAN dealer promptly.

### WARNING LIGHTS

 or **ABS** Anti-lock Braking System (ABS) warning light (if so equipped)

When the ignition switch is in the ON position, the Anti-lock Braking System (ABS) warning

light illuminates and then turns off. This indicates the ABS is operational.

If the ABS warning light illuminates while the engine is running, or while driving, it may indicate the ABS is not functioning properly. Have the system checked by a NISSAN dealer.

If an ABS malfunction occurs, the anti-lock function is turned off. The brake system then operates normally, but without anti-lock assistance. (See "Brake system" in the "5. Starting and driving" section.)

While the rear differential lock-up switch is in the ON position (DIFF-LOCK is on), the ABS warning light flashes. This indicates that anti-lock may not fully operate.

If the light comes on while driving, contact a NISSAN dealer for repair.

 Automatic transmission check warning light (5-speed A/T models)

This light indicates both the "Automatic transmission oil temperature warning" and the "Fail-safe operation".

**Automatic transmission oil temperature warning:**

This light comes on when the automatic transmission oil temperature is too high. If the light comes on while driving, reduce the vehicle speed as soon as safely possible until the light turns off.

**Fail-safe operation:**

When the ignition switch is turned ON, the light comes on for 2 seconds. If the light blinks for approximately 8 seconds, it may indicate the automatic transmission is not functioning properly. Have a NISSAN dealer check and repair the transmission.

### CAUTION:

Continued vehicle operation when the automatic transmission check warning light is on may damage the automatic transmission.

 Automatic transmission oil temperature warning light (4-speed A/T models)

This light comes on when the automatic transmission oil temperature is too high. If the light comes on while driving, reduce the vehicle speed as soon as safely possible until the light turns off.

### CAUTION:

Continued vehicle operation when the automatic transmission oil temperature warning light is on may damage the automatic transmission.

 Automatic transmission park warning light (A/T models)

This light comes on when the automatic transmission selector lever is shifted to the P (Park) position with the transfer shift lever in the N position.

Shift the transfer shift lever into the 2H, 4H or 4L position when the automatic transmission park warning light comes on.

This light indicates that parking function is not engages. If the transfer control is not secured in any drive position while the automatic transmission selector lever is in the P position, the transmission will disengage and the wheel will not lock.

 Brake warning light

This light functions for both the parking brake and the foot brake systems.

**Parking brake indicator:**

The light comes on when the parking brake is applied.

**Low brake fluid warning:**

The light warns of a low brake fluid level. If the light comes on while the engine is running with the parking brake not applied, stop the vehicle and perform the following:

1. Check the brake fluid level. Add brake fluid as necessary. See "Brake and clutch fluid" in the "8. Maintenance and do-it-yourself" section.

 **WARNING:**

If the level is below the MIN (minimum) mark on the brake fluid reservoir, do not drive until the brake system has been checked at a NISSAN dealer.

2. If the brake fluid level is correct, have the

warning system checked by a NISSAN dealer.

#### Low vacuum warning (if so equipped for diesel engine models):

If the light comes on while the engine is running with the parking brake not applied, check the brake fluid level. If the brake fluid level is sufficient, have the brake power assist unit checked for leakage by a NISSAN dealer.

The light may also come on for a few seconds if the brake pedal is depressed quickly and repeatedly. This occurs due to a momentary decrease in vacuum in the brake booster and does not indicate a malfunction of the brake system.



#### WARNING:

- Even if you judge it to be safe, have your vehicle towed because driving it could be dangerous.
- Depressing the brake pedal with the engine stopped could increase your stopping distance and require greater pedal travel distance and effort.



#### Charge warning light

If the light comes on while the engine is running, it may indicate the charging system is not functioning properly. Turn the engine off and check the alternator belt. If the belt is loose, broken,

missing or if the light remains on, see a NISSAN dealer immediately.

#### CAUTION:

**Do not continue driving if the alternator belt is loose, broken or missing.**



#### Door open warning light (if so equipped)

This light comes on when any of the doors and/or back door is not closed securely while the ignition switch is ON.



#### Engine oil pressure warning light

This light warns of low engine oil pressure.

Except for European and Australian ZD30DDTi engine models:

If the light flickers or comes on during normal driving, pull off the road in a safe area, stop the engine immediately and call a NISSAN dealer or other authorized repair shop.

#### CAUTION:

- Running the engine with the engine oil pressure warning light on could cause serious damage to the engine.
- The engine oil pressure warning light is not designed to indicate a low oil level.

**Regularly check the engine oil level using the dipstick. (See "Engine oil" in the "8. Maintenance and do-it-yourself" section.)**

For European and Australian ZD30DDTi engine models:

If the light flickers or comes on during normal driving, pull off the road in a safe area and stop the vehicle immediately. In more than 5 minutes after the engine has been turned off, check the engine oil level and perform as follows:

1. If the engine oil still remains (including the case that the oil sticks to a point of the dipstick), drive **below 3,000 rpm** to the nearest NISSAN dealer and have your vehicle checked.
2. If the engine oil is running short (i.e. when no oil sticks to the dipstick), call a NISSAN dealer **without further driving. Running the engine with the engine oil pressure warning light on could cause serious damage to the engine.**

#### CAUTION:

**The engine oil pressure warning light is not designed to indicate a low oil level. Regularly check the engine oil level using the dipstick. (See "Engine oil" in the "8. Maintenance and do-it-yourself" section.)**



#### Seat belt warning light (if so equipped)

The light reminds you to fasten seat belts. The light illuminates whenever the ignition switch is turned ON and will remain illuminated until the driver's seat belt is fastened.



#### Sub fuel tank warning light (if so equipped)

If this light comes on while the engine is running, it may indicate the sub tank control system is not functioning properly. Have the system checked by a NISSAN dealer.



#### Supplemental restraint system (SRS) air bag warning light (if so equipped)

After turning the ignition switch to the ON position, the supplemental restraint system (SRS) air bag warning light will illuminate. The SRS air bag warning light will turn off after about 7 seconds if the system is operational.

If any of the following conditions occur, the air bag and pre-tensioner seat belt (if so equipped) need servicing and the vehicle must be taken to a NISSAN dealer.

- The SRS air bag warning light remains on after approximately 7 seconds.

- The SRS air bag warning light flashes intermittently.

- The SRS air bag warning light does not come on at all.

Unless checked and repaired, the SRS air bag system and/or the pre-tensioner seat belt may not function properly. For additional details, see the "1. Safety — seats, seat belts and supplemental restraint system" section.



#### Water in fuel filter warning light (if so equipped for diesel engine models)

If the light comes on (and a chime sounds if so equipped) while the engine is running, it warns that you need to immediately drain the water from the fuel filter. See "Fuel filter" in the "8. Maintenance and do-it-yourself" section. **Failure to drain water can cause serious damage to the engine.**

#### INDICATOR LIGHTS



#### Automatic transmission position indicator light (5-speed A/T models)

When the ignition switch is turned to the ON position, the indicator in the tachometer shows the automatic transmission selector lever position. See "Driving with automatic transmission

(5-speed models)" in the "5. Starting and driving" section.



#### Cruise control on indicator light (if so equipped)

The light comes on when the main switch is pushed. The light goes out when the main switch is pushed again. When the cruise control on indicator light comes on, the cruise control system is operational. See "Cruise control" in the "5. Starting and driving" section.



#### Cruise set indicator light (if so equipped)

The light comes on while the vehicle speed is controlled by the cruise control system. If the light flickers while the engine is running, it may indicate that the cruise control system is not functioning properly. Have the system checked by a NISSAN dealer. See "Cruise control" in the "5. Starting and driving" section.



#### Four-wheel drive (4WD) mode indicator light

This light comes on when the transfer shift lever is in the 4H or 4L position. See "Four-wheel drive (4WD)" in the "5. Starting and driving" section.



### Glow plug indicator light (diesel engine models)

This light comes on when the ignition switch is ON, and goes out when the glow plugs have been preheated. When the engine is cold, the glow plug warm-up time will be longer.



### High beam indicator light (blue)

This light comes on when the headlight high beam is on, and goes out when the low beam is selected.



### Malfunction indicator (light) (if so equipped)

This light functions for the "Water in fuel filter warning" (if so equipped) and engine control malfunction indicator.

#### Water in fuel filter warning (if so equipped for diesel engine models):

If the light comes on while the engine is running, it may warn that you need to drain water from the fuel filter. **This should be checked immediately.** See "Fuel filter" in the "8. Maintenance and do-it-yourself" section. **Failure to drain water can cause serious damage to the engine.**

#### Malfunction indicator light function for engine control:

When the ignition switch is in the ON position, the malfunction indicator light illuminates. After starting the engine, the light turns off. This indicates that the engine control system is operational.

If the malfunction indicator light illuminates or blinks (if so equipped) while the engine is running, it may indicate that the engine control system is not functioning properly and may need servicing. Have the system checked, and if necessary repaired, by a NISSAN dealer promptly.

#### Malfunction indicator on steady

An engine control system malfunction has been detected. Have the vehicle checked, and if necessary repaired, by a NISSAN dealer promptly. You do not need to have your vehicle towed to the dealer.

#### Malfunction indicator blinking (if so equipped)

An engine misfire has been detected which may damage the engine control system. Have the vehicle checked, and if necessary repaired, by a NISSAN dealer promptly.

#### Precautions

To reduce or avoid possible damage to the engine control system when the Malfunction Indicator Light illuminates or blinks:

- Avoid driving at speeds above 70 km/h (43 MPH).
- Avoid sudden acceleration or deceleration.
- Avoid going up steep uphill grades.
- Avoid carrying or towing unnecessary loads.

#### CAUTION:

- **Continuing vehicle operation without proper servicing of the engine control system could lead to poor driveability, reduced fuel economy, and damage to the engine control system, which may affect the vehicle's warranty coverage.**
- **Incorrect setting of the engine control system may lead to non-compliance of local and national emission laws and regulations.**



### Overdrive off indicator light (4-speed A/T models)

This light comes on when the overdrive switch is pushed to the "OFF  " position.



### Rear differential lock (DIFF-LOCK) indicator light (if so equipped)

When the rear differential lock up switch is in the ON position, this light will blink and then stay on after the differential gear is completely locked.

See "Rear differential lock-up switch" later in this section.



### Rear fog light indicator light (if so equipped)

The light comes on when the rear fog light switch is turned on.



### Rear stabilizer off indicator light (if so equipped)

This light comes on when the rear stabilizer release switch is in the OFF position.

See "Rear stabilizer release switch" later in this section.



### Turn signal/hazard indicator lights

The lights flash when the turn signal switch or hazard switch is turned on.

#### AUDIBLE REMINDERS

##### Brake pad wear warning

The disc brake pads have audible wear warnings. When a brake pad requires replacement, it will make a high pitched scraping sound when the vehicle is in motion whether or not the foot brake pedal is depressed. Have the brakes checked as soon as possible if the warning sound is heard.

##### Rear differential lock (DIFF-LOCK) warning chime (if so equipped)

The chime sounds when the vehicle speed exceeds 20 km/h (12 MPH) with the rear differential lock-up switch in the ON position.

See "Rear differential lock-up switch" later in this section.

##### Key reminder chime (if so equipped)

###### Type A:

The chime will sound if the driver side door is opened while the key is left in the ignition switch (ignition switch is turned off). Remove the key and take it with you when leaving the vehicle.

###### Type B (Super lock equipped models):

The chime will sound if the driver side door is locked with the door opened while the key is left in the ignition switch (ignition switch is turned

off). Remove the key and take it with you when leaving the vehicle.

##### Light reminder chime (if so equipped)

A chime will sound when the driver side door is opened if the light switch is turned on (ignition switch is in the ACC, OFF or LOCK position). Turn the light switch off when you leave the vehicle.

# WIPER AND WASHER SWITCH

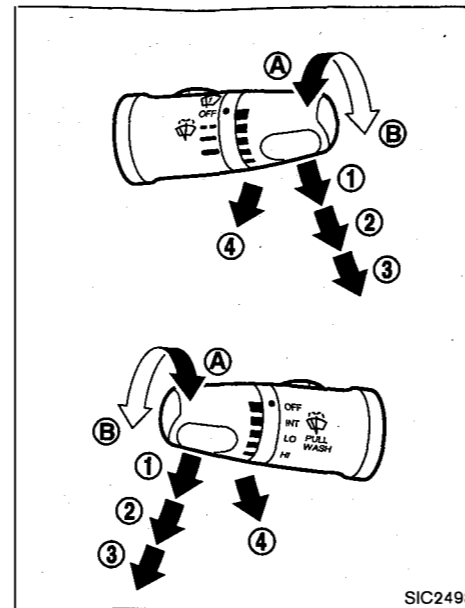
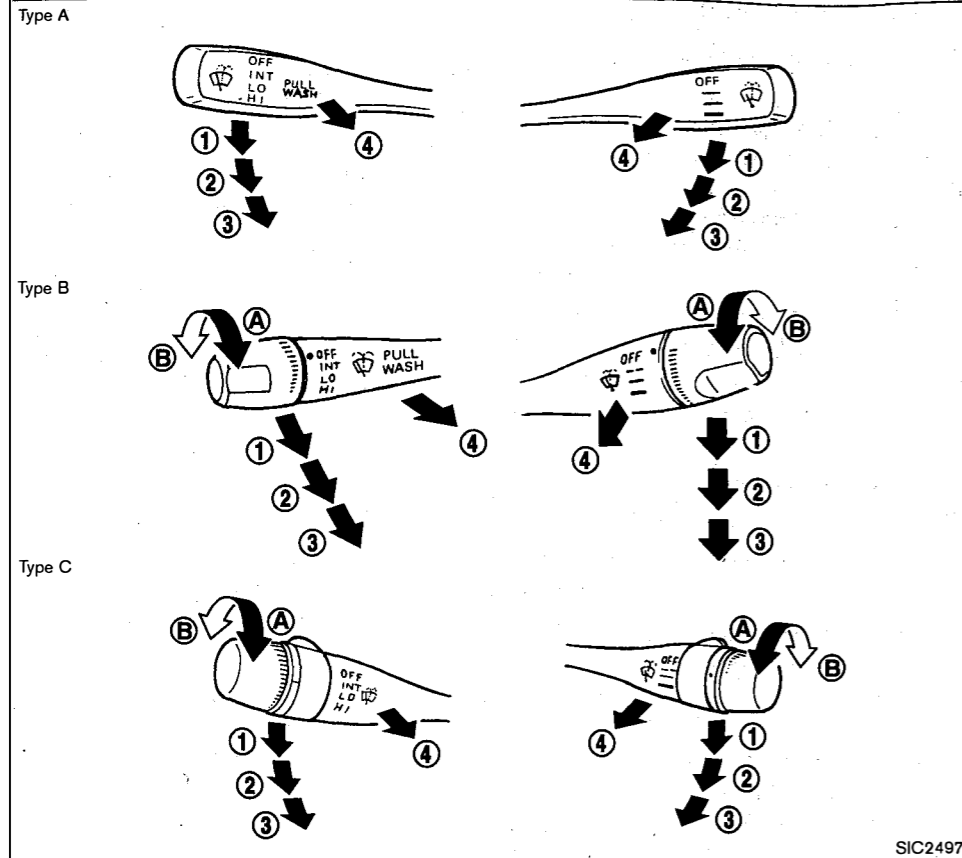

## WINDSHIELD WIPER AND WASHER SWITCH

The windshield wiper and washer operates when the ignition switch is in the "ON" position. Push the lever down to operate the wiper at the following speed:

① Intermittent — intermittent operation can be

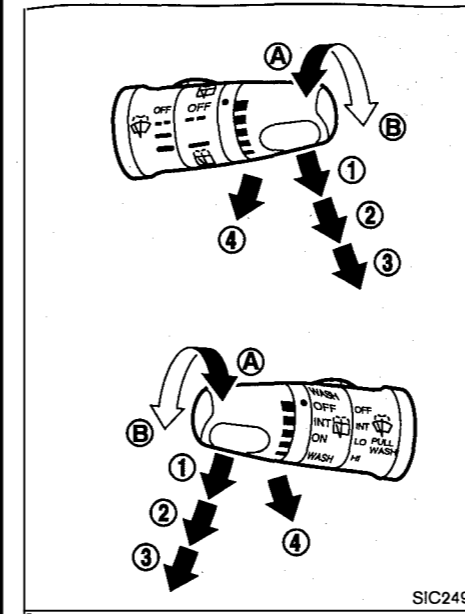

adjusted by turning the knob toward **A** (Slower) or **B** (Faster) (if so equipped).

② Low — continuous low speed operation

③ High — continuous high speed operation

Pull the lever toward you ④ to operate the washer. Then the wiper will also operate several times.

### CAUTION:

- Do not operate the washer continuously for more than 30 seconds.
- Do not operate the washer if the reservoir is empty.

### WARNING:

In freezing temperatures the washer fluid may freeze on the windshield and obscure your vision. Warm the windshield with the defroster before you wash the windshield.

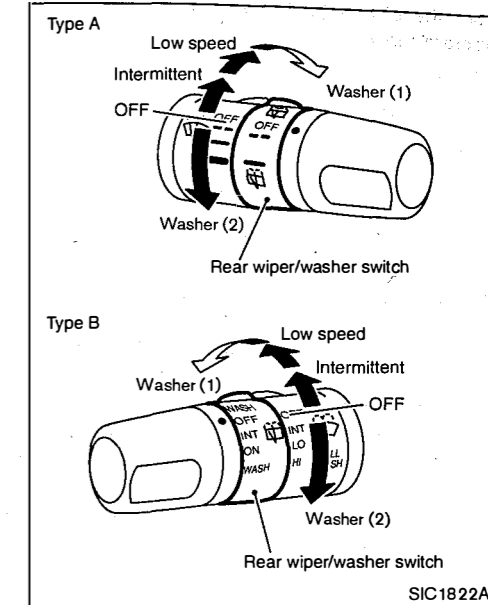

## REAR WINDOW WIPER AND WASHER SWITCH (if so equipped)

The rear window wiper and washer operates when the ignition switch is in the ON position.

Turn the switch to the intermittent, low speed or washer (1) position to operate the wiper or washer.

Turn the switch to the washer (2) position to operate the washer.

Then the wiper will also operate several times.

**CAUTION:**

- Do not operate the washer continuously for more than 30 seconds.
- Do not operate the washer if the reservoir is empty.



**WARNING:**

In freezing temperatures the washer fluid may freeze on the rear window and obscure your vision. Warm the rear window with the defogger before you wash the rear window.

**DEFOGGER SWITCH (if so equipped)**

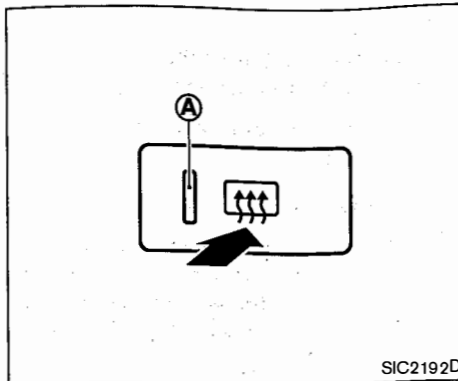

The rear window and outside door mirror (if so equipped) defogger switch operates when the ignition switch is in the ON position.

The defogger is used to reduce the moisture, fog or frost on the rear window and outside door mirror surfaces to improve the rear and side views.

When the defogger switch is pushed, the indicator light **A** illuminates and the defogger operates for approximately 15 minutes. After the preset time has passed, the defogger will turn off automatically.

To turn off the defogger manually, push the defogger switch again.

**CAUTION:**

- When operating the defogger continuously, be sure to start the engine. Otherwise, it may cause the battery to discharge.
- When cleaning the inner side of the window, be careful not to scratch or damage the electrical conductors on the surface of the window.

**WINDSHIELD DEICER SWITCH (if so equipped)**

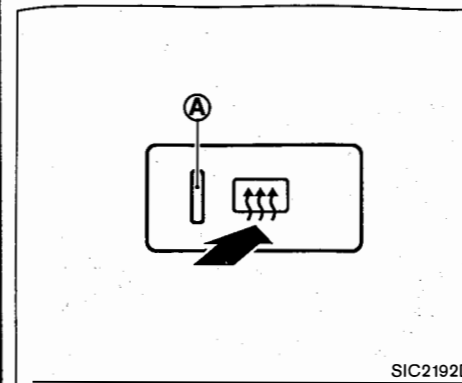

The windshield deicer switch (defogger switch) operates when the ignition switch is in the ON position.

The deicer is used to remove ice from the windshield when a wiper is frozen to the windshield.

When the switch is pushed, the indicator light **A** illuminates and the deicer operates for approximately 15 minutes. The rear window defogger will activate at the same time. After the preset time has passed, the deicer will turn off automatically.

To turn off the deicer manually, push the deicer switch again.

**CAUTION:**

- When operating the deicer continuously, be sure to start the engine. Otherwise, it may cause the battery to discharge.
- When cleaning the inner side of the window, be careful not to scratch or damage the electrical conductors on the surface of the window.

**HEADLIGHT AND TURN SIGNAL SWITCH**

**XENON HEADLIGHTS (if so equipped)**



**WARNING:**



**HIGH VOLTAGE**

- When xenon headlights are on, they produce a high voltage. To prevent an electric shock, never attempt to modify or disassemble. Always have your xenon headlights replaced at a NISSAN dealer.
- Xenon headlights provide considerably more light than conventional headlights. If they are not correctly aimed, they might temporarily blind an oncoming driver or the driver ahead of you and cause a serious accident. If headlights are not aimed correctly, immediately take your vehicle to a NISSAN dealer and have the headlights adjusted correctly.

When the xenon headlight is initially turned on, its brightness or color varies slightly. However, the color and brightness will soon stabilize.

- The life of xenon headlights will be shortened by frequent on-off operation. It is generally desirable not to turn off the headlights for short intervals (for



example, when the vehicle stops at a traffic signal).

- If the xenon headlight bulb is close to burning out, the brightness will drastically decrease, the light will start blinking, or the color of the light will become reddish. If one or more of the above signs appear, contact a NISSAN dealer.

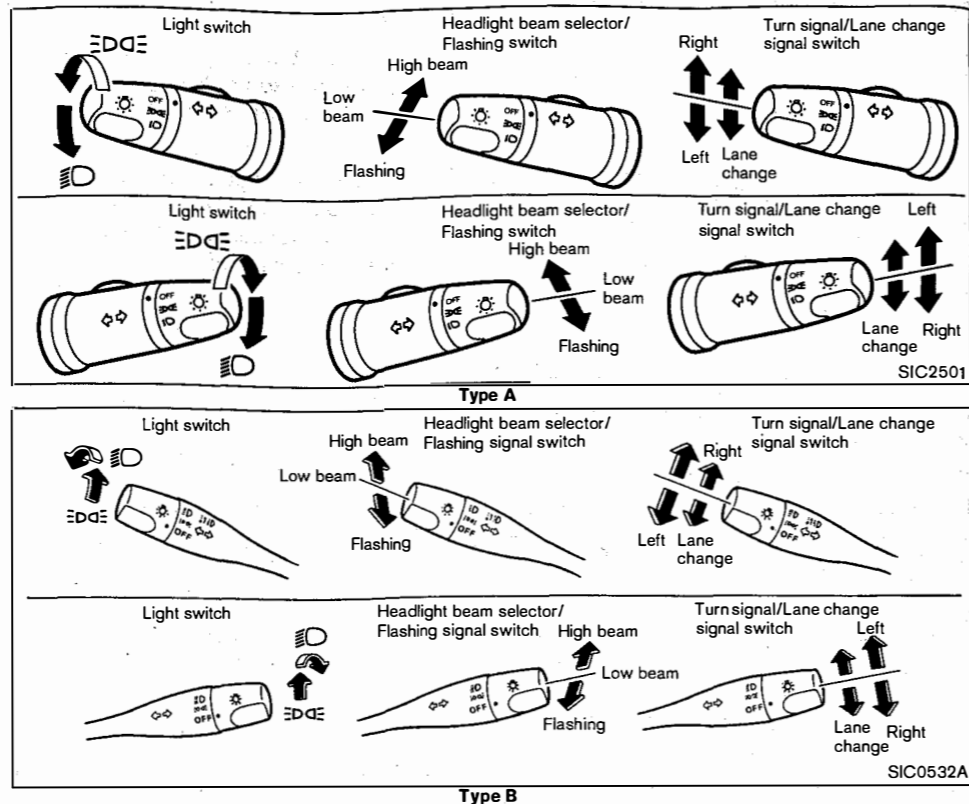

## HEADLIGHT SWITCH

NISSAN recommends you should consult the local regulations on the use of lights.

### Lighting

Turn the switch to the position:

The front clearance, tail, license plate and instrument lights will come on.

Turn the switch to the position:

Headlights will come on and all the other lights remain on.

To select the high beam, push the lever forward. Pull it back to select the low beam.

Pulling the lever toward you will flash the headlight even when the headlight switch is off.

## TURN SIGNAL SWITCH

### Turn signal

Move the lever up or down to signal the turning direction. When the turn is completed, the turn signals cancel automatically.

### Lane change signal

To indicate a lane change, move the lever up or down to the point where lights begin flashing.

## Daytime light system (if so equipped)

Even if the light switch is off, the headlight low beam, clearance, tail, license and instrument lights will come on after starting the engine. However, you cannot change low beam to high beam when the light switch is off.

When the light switch is turned to the position, the headlight low beam will be off.

### CAUTION:

**Never leave the light switch on when the engine is not running for extended periods of time.**

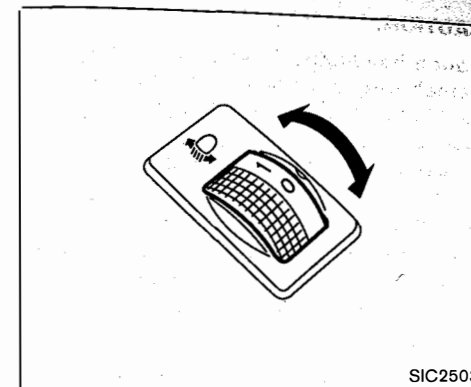

## HEADLIGHT AIMING CONTROL SWITCH (if so equipped)

Depending on the number of occupants in the vehicle and the load it is carrying, the headlight axis may be higher than desired. If the vehicle is traveling on a hilly road, the headlights may directly hit the rearview mirror of the vehicle ahead or the windshield of the oncoming vehicle. The light axis can be lowered with the operation of the switch.

The larger the number designated on the switch, the lower the axis.

When traveling with no heavy load or on a flat road, select position 0.

**CAUTION:**

Xenon headlights (if so equipped) are extremely bright compared to conventional headlights. If the xenon headlights hit the rearview mirror of the vehicle ahead or the windshield of the oncoming vehicle, the driver of these vehicles may have difficulty driving because of the brightness. Use the headlight aiming control switch to lower the light axis. See "Xenon headlights" earlier in this section for information on xenon headlights.

Adjust the switch by referring to the following examples:

## For Wagon models

Switch position	Number of front seat occupants	Number of rear seat occupants	Weight of load in the luggage compartment
0	1 or 2	No occupants	No load
	2	2	No load
1	2	3 or 5	No load
2	2	3	Approximately 269 kg (593 lb)
		5	Approximately 84 kg (185 lb)
3	1	No occupants	Approximately 437 kg (963 lb)
		When towing a trailer	

## For Hardtop models

Switch position	Number of front seat occupants	Number of rear seat occupants	Weight of load in the luggage compartment
0	1 or 2	No occupants	No load
1	2	3	No load
3	2	3	Approximately 176 kg (388 lb)
	1	No occupants	Approximately 476 kg (1,049 lb)
			When towing a trailer

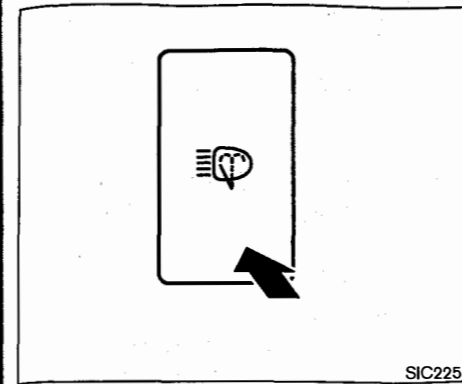
**HEADLIGHT CLEANER SWITCH (if so equipped)**

SIC2255

The headlight cleaner operates when the headlight switch is in the  $\text{☀}$  or  $\text{☀}$  position and the ignition switch is in the ON position.

Push the switch to operate the headlight cleaner. To be sure the cleaner operates, keep the switch pushed for about 1 second.

**CAUTION:**

- Do not operate the headlight cleaner continuously for more than 30 seconds.
- Do not operate the cleaner if the washer fluid reservoir is empty.

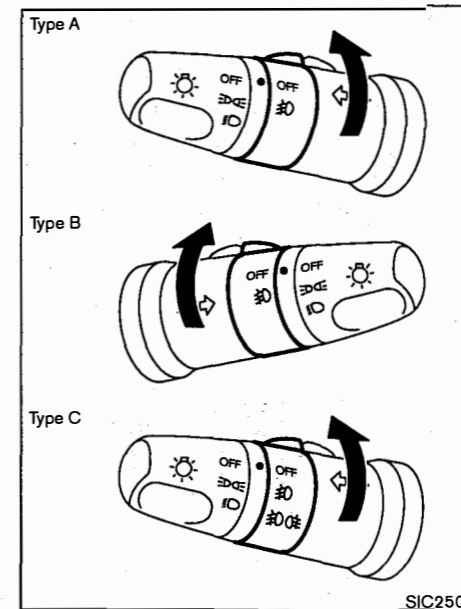
**FOG LIGHT SWITCH (if so equipped)**

SIC2504

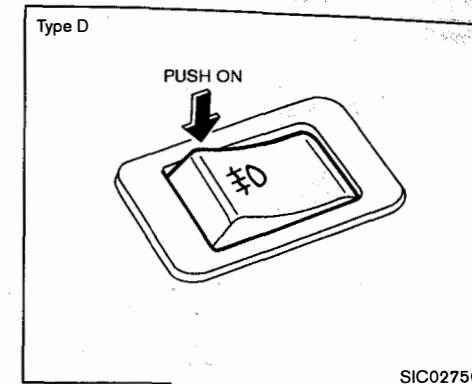

SIC0275C

$\text{☀}$  position for the fog lights to operate.

**Types D and E:**

The fog light switch operates when the headlight switch is in the  $\text{☀}$  or  $\text{☀}$  position.

Push the switch on to turn on the fog lights.

**FRONT FOG LIGHTS****Types A to C:**

To turn the fog lights on, turn the headlight switch to the  $\text{☀}$  or  $\text{☀}$  position, then turn the fog light switch to the  $\text{☀}$  position. To turn them off, turn the switch to the OFF position.

The headlight switch must be in the  $\text{☀}$  or

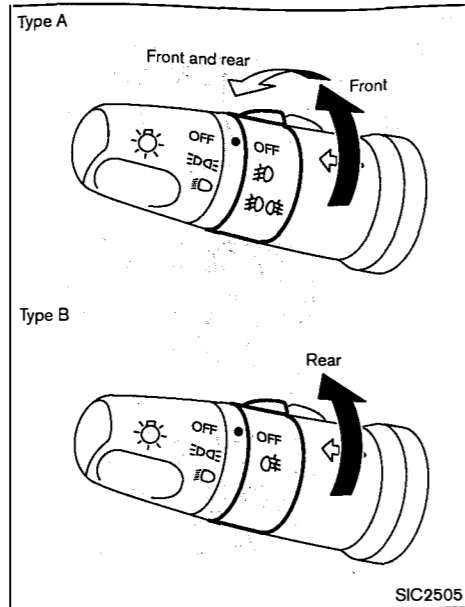
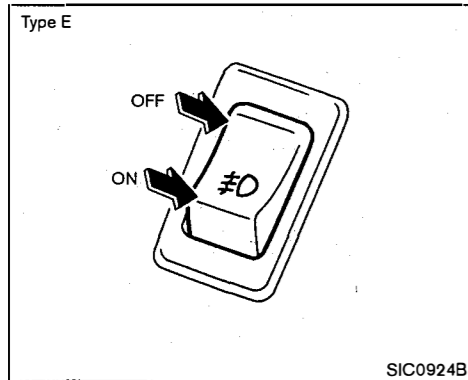

### REAR FOG LIGHT

The rear fog light should be used only when visibility is seriously reduced. [Generally, to less than 100 meters (328 ft)]

#### Type A:



Turn the headlight switch to the  or  po-

sition. Then turn the fog light switch to the  position.

The rear fog light will come on with the front fog lights.

When the headlight switch is turned to the OFF position, the rear fog light switch automatically moves along to the  (front fog lights) position.

#### Type B:

Turn the headlight switch to the  position. Then turn the fog light switch to the  position. The rear fog light will come on.

When the headlight switch is turned to the OFF position, the rear fog light switch automatically moves along to the OFF position.

As the fog light switch is being turned to OFF, the headlight switch will not move with it.

### HAZARD WARNING FLASHER SWITCH

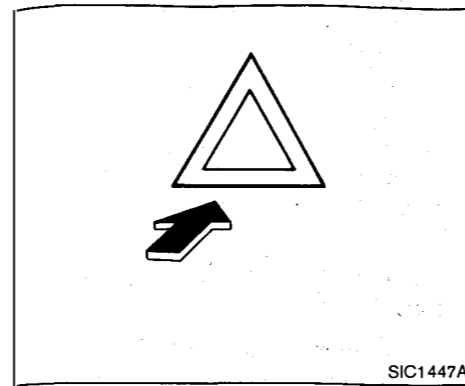

Push the switch on to warn other drivers when you must stop or park under emergency conditions. All turn signal lights will flash.

### HORN

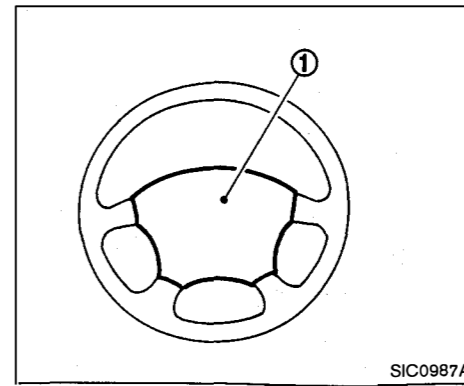

To sound the horn, push the center pad area ① of the steering wheel.

### SUB FUEL TANK TRANSFER SWITCH (if so equipped)

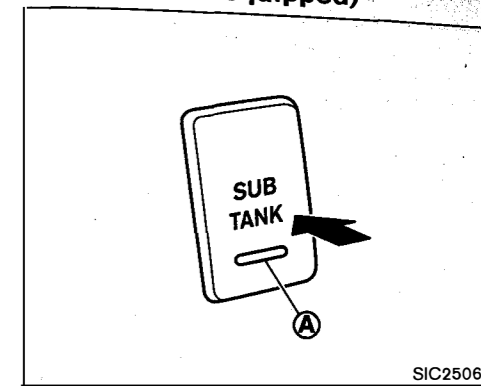

#### Type A

Fuel can be transferred from the sub tank to the main tank by pushing the switch. The indicator light **A** will illuminate to indicate that fuel is being transferred. As soon as fuel transfer is completed, the switch automatically turns off and the indicator light goes out. To suspend fuel transfer, push the switch one time.

Each time the engine is started, fuel is automatically transferred from the sub tank to the main tank for a few seconds.

- Sometimes fuel cannot be transferred when the main tank is close to full or the sub tank is close to empty.
- Fuel transfer may stop when driving on rough roads, turning, or climbing a

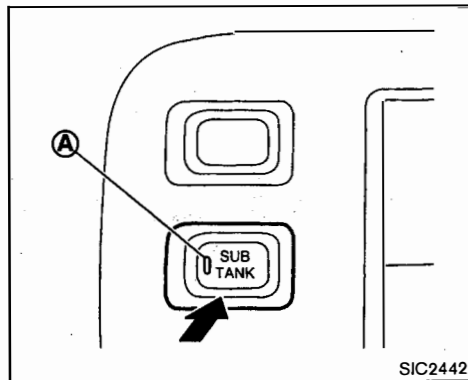

**slope during transfer as the fuel level fluctuation is large. In this case, push the switch on again.**

If the sub fuel tank warning light **SUB TANK** (in the meter) comes on while the engine is running, it may indicate the sub fuel tank control system is not functioning properly. Have the system checked by a NISSAN dealer.

## REAR DIFFERENTIAL LOCK-UP SWITCH (if so equipped)

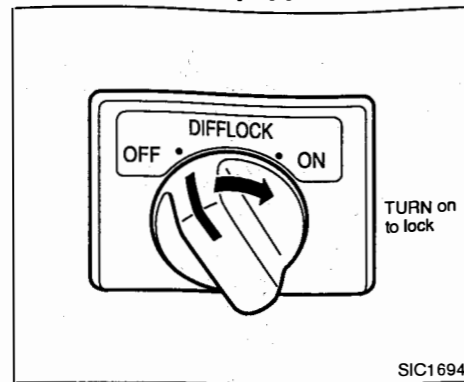

The rear differential lock (DIFF-LOCK) is designed to transmit engine power to the left and right wheels equally.

If your vehicle is stuck in sand, snow, mud, etc. or one wheel is off the ground and the differential lock is not on, engine power is transmitted to one wheel causing it to spin, so leaving insufficient traction on the other wheel. The rear differential lock allows the left and right wheels to rotate as a unit, enabling your vehicle to free itself.

To lock the rear differential gear, reduce the vehicle speed below 7 km/h (4 MPH) and shift the transfer shift lever into the 4L or 4H position. Then turn the rear differential lock-up switch to the ON position. The rear differential lock (DIFF-

LOCK) indicator light "DIFF LOCK" will blink and then stay on when the differential gear is completely locked.

After using the rear differential lock (DIFF-LOCK), or during normal driving, turn the rear differential lock-up switch OFF. The DIFF-LOCK indicator light will turn off after the differential lock is released.

- The rear differential lock-up device operates only when the engine is running.
- In two-wheel drive (2WD) mode (2H position), the rear differential lock-up device does not operate if the rear differential lock-up switch is turned to the ON position. (The DIFF-LOCK indicator light will flash.)

### WARNING:

- Use the rear differential lock (DIFF-LOCK) only in an emergency when it is not possible to free a stuck vehicle even using the 4L position.
- When the DIFF-LOCK is in operation, turning the vehicle becomes hard and,

especially at high speeds, is dangerous.

- While DIFF-LOCK is on, the anti-lock braking system (ABS) warning light flashes. This indicates that anti-lock function may not fully operate. (ABS only)
- Do not operate the DIFF-LOCK when the vehicle is turning or when one side wheel is rotating. Otherwise the power train system parts could be damaged.
- Avoid quick starts while the DIFF-LOCK is in operation. Otherwise the power train system parts could be damaged.

Observe the above precautions. Otherwise, loss of normal steering control may result.

## REAR STABILIZER RELEASE SWITCH (if so equipped)

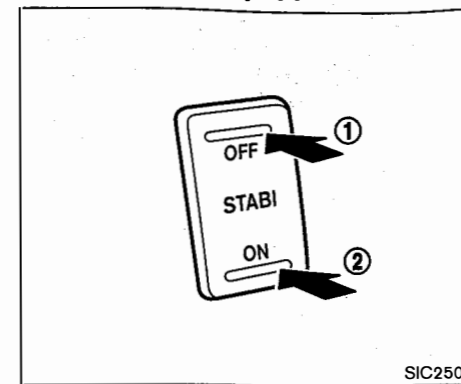

On the console box

To release the rear stabilizer, push the "OFF" side ① of the switch at vehicle speeds of up to 20 km/h (12 MPH). The "STABI OFF" indicator light will come on. While the rear stabilizer is released, the vehicle can be driven smoothly on rough roads.

To hold the rear stabilizer again, push the "ON" side ② of the switch. (The "STABI OFF" indicator light will turn off after about 4 seconds.) Roll the vehicle lightly by cornering, etc.

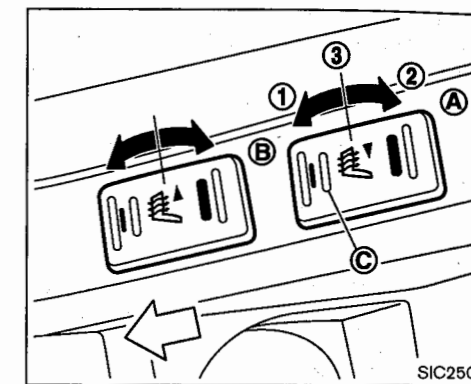

For normal driving, keep the rear stabilizer locked.

## HEATED SEATS (if so equipped)



The front seat(s) are warmed by built-in heaters. The switches located on the center console can be operated independently of each other (A for left side seat, B for right-side seat).

1. Start the engine.
2. Select heat range.

- ① For low heat, press the  (Low) side of the switch.
- ② For high heat, press the  (High) side of the switch.
- ③ For no heat, the switch has a center OFF position between low and high.

The indicator light C in the switch will illuminate when Low or High is selected.

The heater is controlled by a thermostat, automatically turning the heater on and off. The indicator light will remain on as long as the switch is on.

- When the vehicle's interior is warmed or before you leave the vehicle, be sure to turn the switch to the OFF position ③.

**CAUTION:**

- The battery could run down if the seat heater is operated while the engine is not running.
- Do not use the seat heater for extended periods or when no one is using the seat.
- Do not put anything on the seat which insulates heat, such as a blanket, cushion, seat cover, etc. Otherwise, the seat may become overheated.
- Do not place anything hard or heavy on the seat or pierce it with a pin or similar object. This may result in damage to the seat heater.
- Any liquid spilled on the heated seat should be removed immediately with a dry cloth.
- When cleaning the seat, never use gasoline, thinner, or any similar materials.

- If any malfunctions are found or the heated seat does not operate, turn the switch OFF and have the system checked by a NISSAN dealer.

**CLOCK (if so equipped)**

If the battery cable is disconnected, the clock will reset its time and the correct time will not be indicated. Readjust the time.

**Type A:**

The digital clock displays all the time. When the ignition switch is in the ACC or ON position, or the light switch is on, an illumination light will come on.

**Type B:**

The digital clock display will come on with an illumination light when the ignition switch is turned to the ON position.

**Types C and D:**

The digital clock (in the audio unit) displays the time when the ignition switch is in the ACC or ON position and the CLOCK ON mode is selected. See "Audio system" in the "4. Display screen, heater and air conditioner, and audio system" section to check whether your radio has a clock display mode.

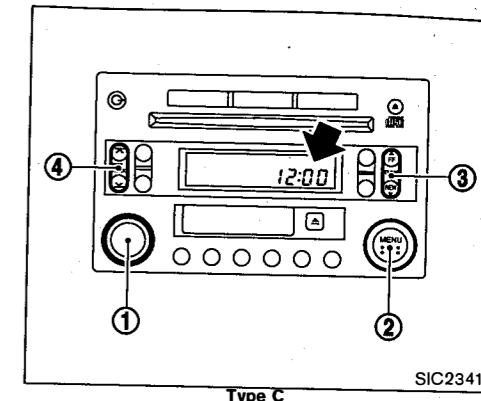
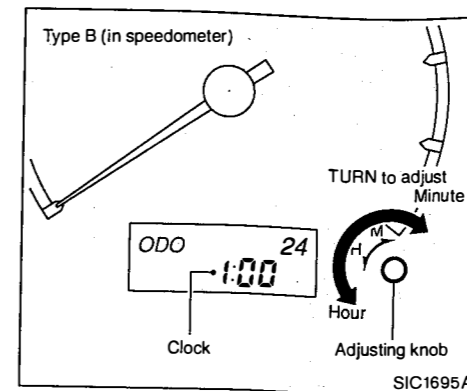
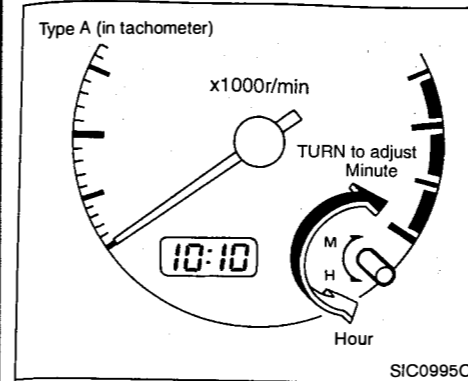

**ADJUSTING THE TIME**

**Meter display model**

Turn the adjusting knob counterclockwise to advance the hour.

Turn the adjusting knob clockwise to advance the minute.

**Audio display model**

You can select clock display ON and OFF mode.

**When the clock is not displayed:**

If the clock is not displayed with the ignition switch in the ACC or ON position, you need to select the clock ON mode as follows:

1. Turn the audio unit on by pushing the ON-OFF/Volume control knob ①.
2. Push the "MENU" button ② until the display indicates the clock adjustment mode ("CLK-OFF" is displayed).
3. Push the "TUNE" button ③ or "SEEK TRACK" button ④ (Type C only) to change the display to "CLK-ON".

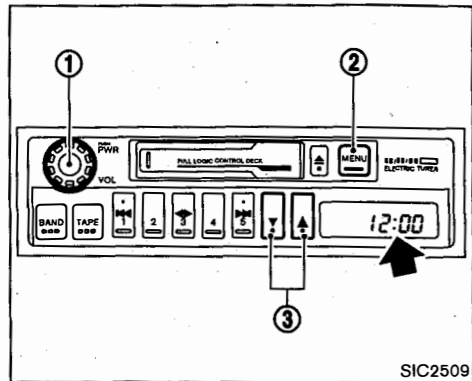

Type D

SIC2509

Then the clock can be adjusted in the following steps:

4. Push the "MENU" button (2).
5. The time indicator will flash.

Type C:

Push the "SEEK TRACK" button (4) to adjust the hour.

Push the "TUNE" button (3) to adjust the minute.

Pushing  $\nearrow$ ,  $\nwarrow$  buttons will advance the time and  $\searrow$ ,  $\swarrow$  buttons will turn back the time.

Type D:

Push the "TUNE" button (3) to adjust the hour.

Pushing the "MENU" button (2) will switch the display to the minute adjustment mode. Then adjust the minute by pushing the "TUNE" button (3). Pushing  $\blacktriangle$  button will advance the time and  $\blacktriangledown$  button will turn back the time.

6. Push the "MENU" button (2) to finish the clock adjustment.

**When the clock is displayed:**

1. Turn the audio unit on by pushing the ON-OFF/Volume control knob (1).
2. Push the "MENU" button (2) until the display indicates the clock adjustment mode ("CLK-ON" is displayed).
3. Perform steps 4 to 6 above to adjust the time.

Type C clock can also be adjusted when the audio unit is off.

**RESETTING THE TIME (for audio display model)**

By holding down the MENU button (2) and then pushing the TUNE button (3), the time will be reset as follows.

- In case the displayed minute is in the range of 00 - 29, the hour will stay the same and the minute will be reset to 00.
- In case the displayed minute is in the range of

30 - 59, the hour will be advanced by one hour and the minute will be reset to 00.

**ASHTRAYS AND CIGARETTE LIGHTER**

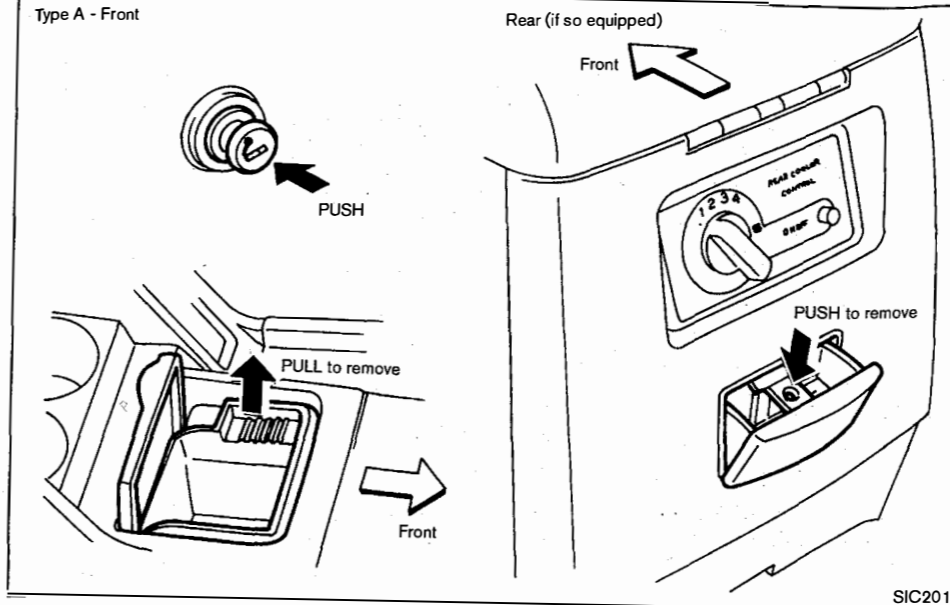

SIC2011

The cigarette lighter operates when the ignition key is in "ACC" or "ON".

Push the lighter in all the way. When the lighter is heated, it will spring out.

Return the lighter to its original position after use.

**CAUTION:**

The cigarette lighter should not be used while driving in order that full attention may be given to the driving operation.

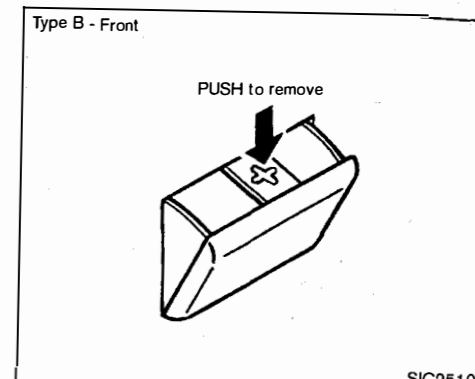

SIC2510

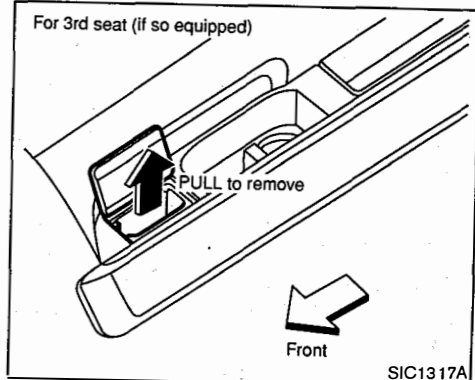

SIC1317A

## POWER OUTLET (if so equipped)

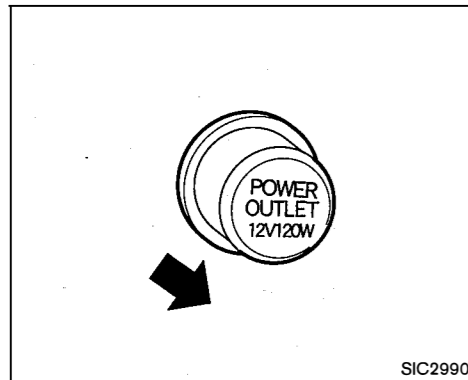

Front

The power outlet is for powering electrical accessories such as cellular telephones.

### CAUTION:

- Use caution as the outlet and plug may be hot during or immediately after use.
- This power outlet is not designed for use with a cigarette lighter unit.
- Do not use with accessories that exceed a 12 volt, 120 W (10A) power draw. Do not use double adapters or more than one electrical accessory.
- Use this power outlet with the engine running. (If the engine is stopped, this could result in a discharged battery.)

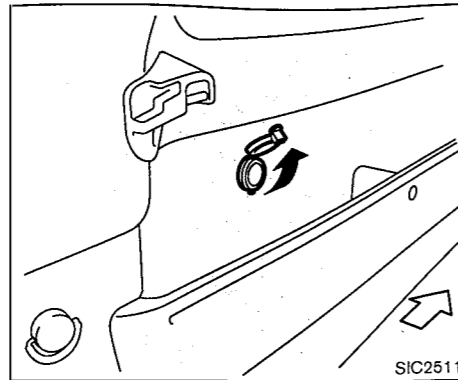

- Avoid using when the air conditioner, headlights or rear window defogger is on.
- When not in use, be sure to close the cap. Do not allow water to contact the socket.
- Before inserting or disconnecting a plug, be sure to turn off the power switch of electrical accessory being used or the ACC power of the vehicle.
- Push the plug in as far as it will go. If good contact is not made, the plug may overheat or the internal temperature fuse may blow.

## STORAGE

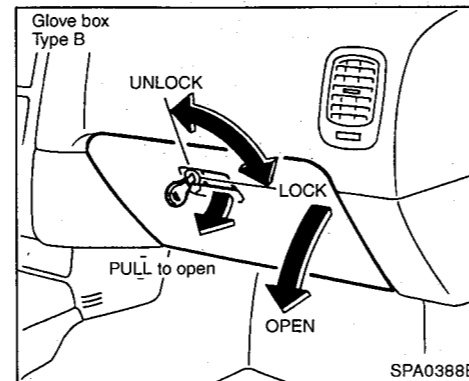
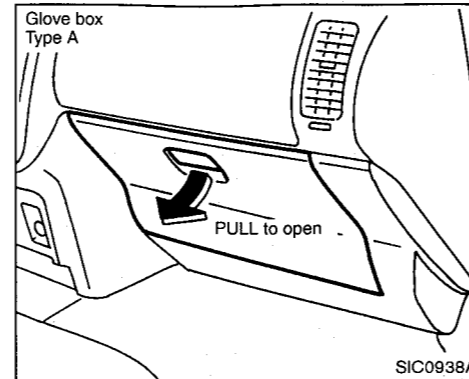

## GLOVE BOX

The glove box will be opened by pulling the handle.

To lock or unlock the glove box, use the key. (Type B)



### WARNING:

Keep glove box lid closed while driving to prevent injury in an accident or a sudden stop.

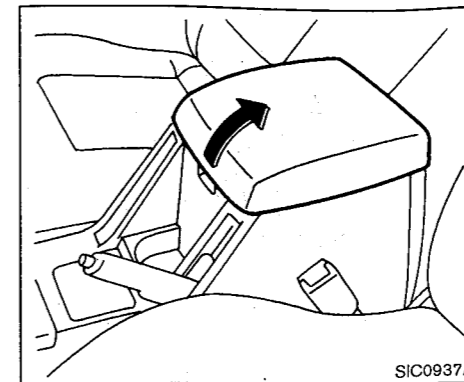

## CONSOLE BOX (if so equipped)



### WARNING:

The console box should not be used while driving so full attention may be given to vehicle operation.

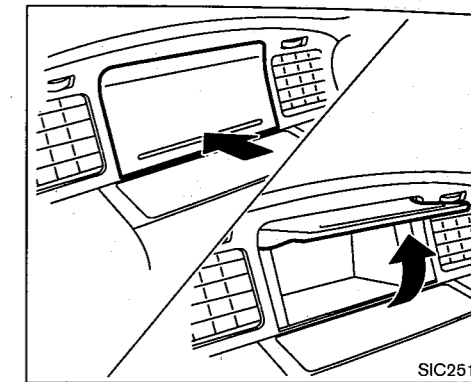

## INSTRUMENT CENTER BOX (if so equipped)



### WARNING:

The instrument center box should not be used while driving so full attention may be given to vehicle operation.

Push the lid to open the instrument center box (upper).

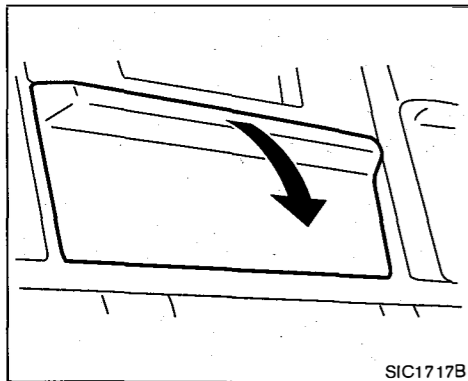

SIC1717B

Lower

Pull the lid to open the instrument center box (lower).

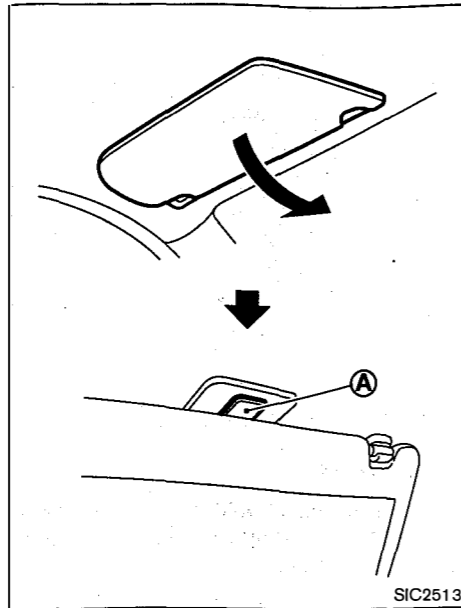

SIC2513

#### CARD HOLDER (if so equipped)

The card holder **A** is located on the ceiling, behind the sun visor.

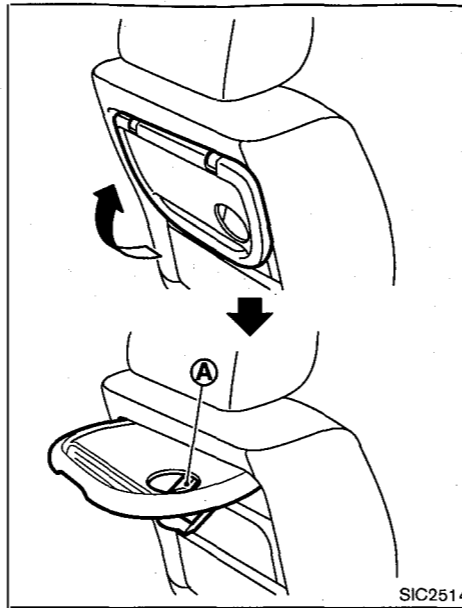

SIC2514

#### SEATBACK TRAY (if so equipped)

The trays are located on the seatbacks of the front seats. To use the seatback tray, pull it up to the fixed position. The tray has a cup holder **A**.

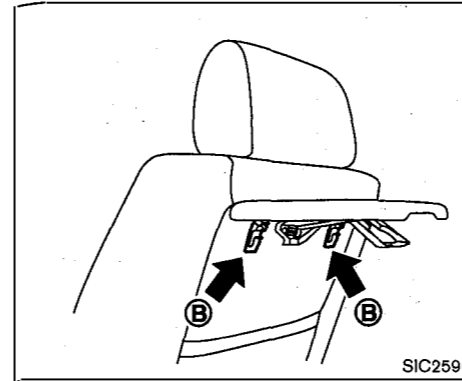

SIC2596

Hooks **B** are located on the base of the seatback tray.

#### CAUTION:

- Make sure that the seatback tray is securely fixed in place before using it.
- Do not place items which are more than 3 kg (6 lb) on the seatback tray. Doing so may damage the tray or fold it down suddenly.
- Do not place items which are more than 3 kg (6 lb) on the hook. This may damage it.
- While the seatback trays are used by the rear passengers, the driver or front pas-

senger must not recline the seats.

- While driving, do not use the seatback tray.
- When the seatback tray is not in use, keep it stored.

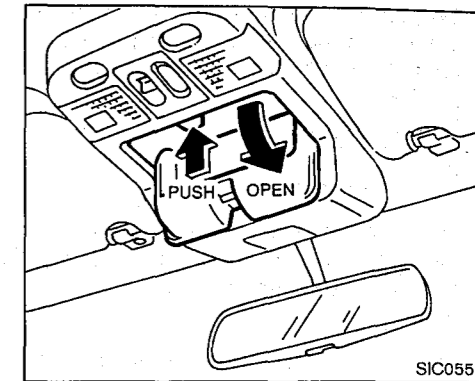

SIC0557

#### SUNGLASSES HOLDER (if so equipped)

The sunglasses holder can be opened by pushing the button.

#### ! WARNING:

- The sunglasses holder should not be used while driving so full attention may be given to vehicle operation.
- Keep the sunglasses holder closed while driving to prevent an accident.

#### CAUTION:

- Do not use for anything other than sunglasses.



- Do not leave sunglasses in the sunglasses holder while parking in direct sunlight. The heat may damage the sunglasses.

#### CUP HOLDERS (if so equipped)

##### WARNING:

- The driver should not insert cups into the cup holder while driving so full attention may be given to vehicle operation.
- Avoid abrupt starting and braking when the cup holder is being used to prevent spilling the drink. If the liquid is hot, it can scald you or your passenger.

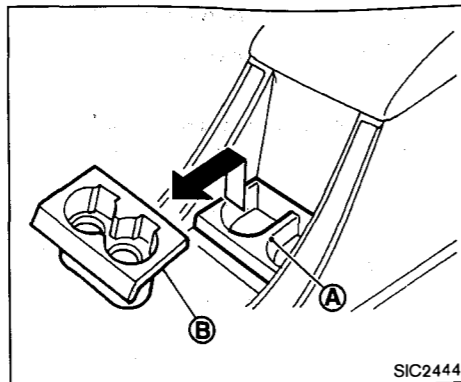

The cup holder **A** is in front of the console box. When you install or remove the extra cup holder **B** (if so equipped), be careful not to scratch the console box.

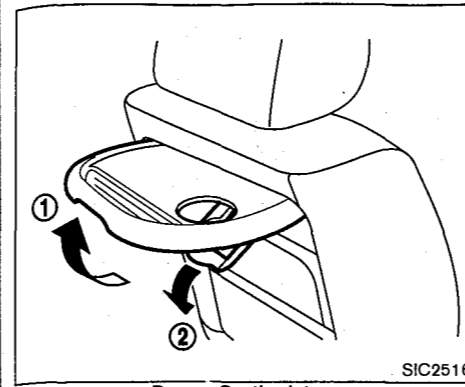
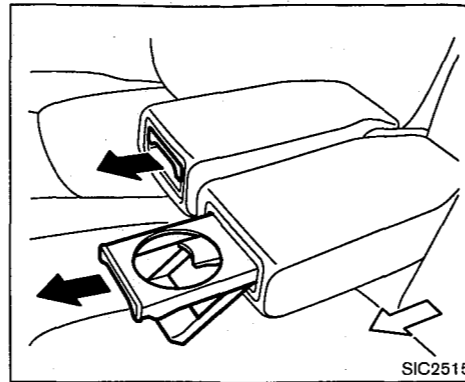

Pull up the seatback tray **1** and pull down the leg of the cup holder **2**.

##### CAUTION:

Do not use the seatback tray and cup holder while driving.

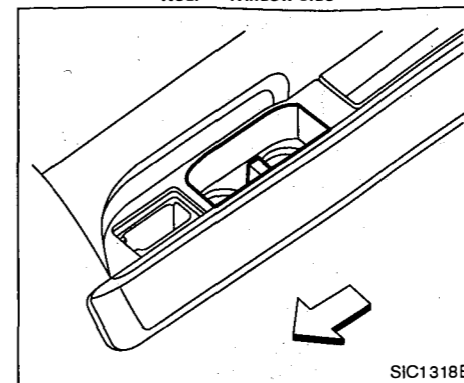
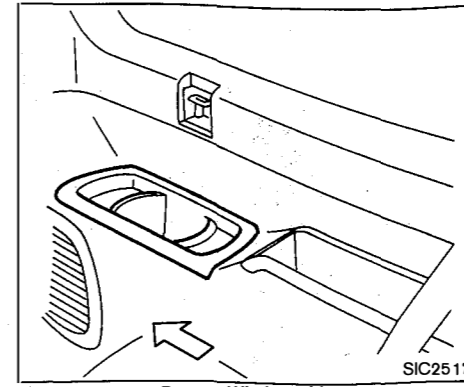

## WINDOWS

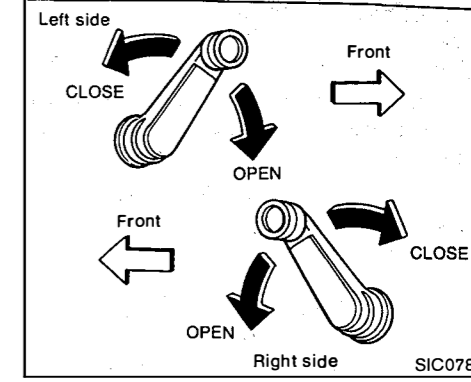

## MANUAL WINDOWS

The side windows can be opened or closed by turning the hand crank on each door.

## POWER WINDOWS

### WARNING:

- Make sure that all passengers have their hands, etc. inside the vehicle before closing the windows.
- Do not leave children unattended inside the vehicle. They could unknowingly activate switches.

The power window operates when the ignition key is in the ON position.

To open the window, push down the switch and hold it. To close the window, pull up the switch and hold it.

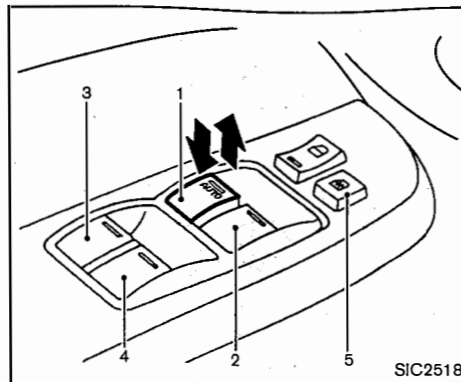

Wagon models

### Driver's side window switch

1. Driver's window
2. Front passenger's window
3. Rear left side window
4. Rear right side window
5. Lock button

The main switch can control all the windows.

### Locking passenger's window:

When the lock button is pushed in, only the driver side window can be opened or closed. Push it in again to cancel.

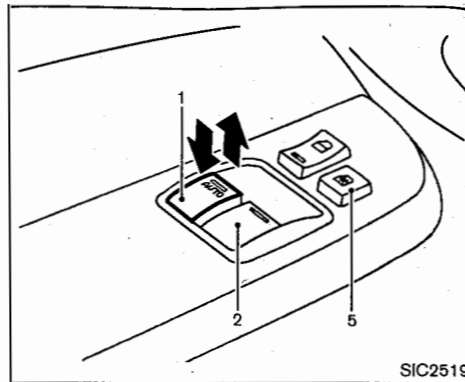

Hardtop and Pickup models

### Window timer (if so equipped):

The window timer allows the driver's window switch to be operated for approximately 15 minutes even if the ignition switch is turned to the "OFF" position and the key is removed from the ignition. The window timer will be cancelled when the driver's door is opened or the preset time has expired.

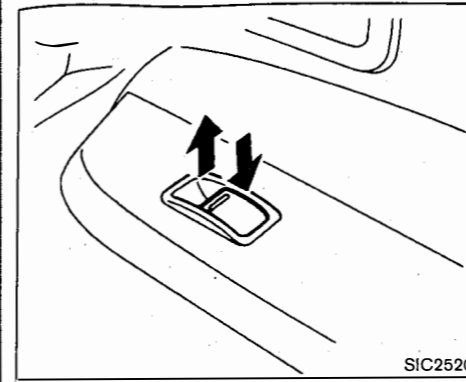

### Passenger's side window switch

The passenger's switch will open or close only the corresponding window.

To open or close the window, push down or pull up the switch and hold it.

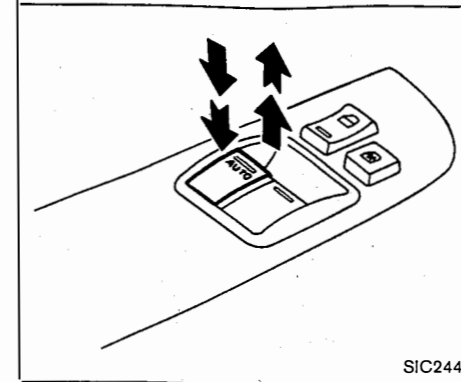

### Automatic function (if so equipped)

To fully open or close the driver side window, completely push down or pull up the switch and release it; it need not be held. The window will automatically open or close all the way. To stop the window, just pull up or push down the switch on the opposite side.

### Auto reverse function:

If the control unit detects something caught in the driver's window as it moves up, the window will be immediately lowered.

The auto reverse function can be activated when the driver's window is closed by automatic operation when the ignition key is in the ON position. If your vehicle is equipped with the

power window timer, the function can be activated for about 15 minutes after the ignition switch is turned to the OFF position.

Depending on the environment or driving conditions, the auto reverse function may be activated if an impact or load similar to something being caught in the window occurs.

### WARNING:

There are some small distances immediately before the closed position which cannot be detected. Make sure that all passengers have their hands, etc., inside the vehicle before closing the window.

## SUNROOF (if so equipped)

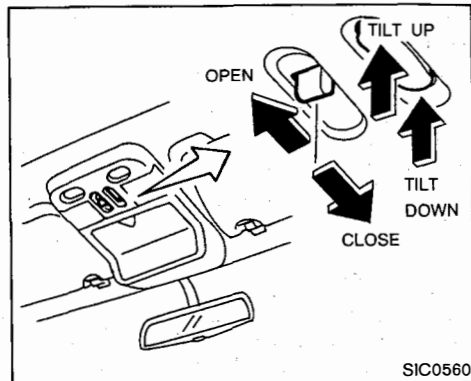

The sunroof will only operate when the ignition key is in the "ON" position.

### Sliding sunroof

To open the roof, press and hold the switch to the "OPEN" side.

To close the roof, press and hold the switch to the "CLOSE" side.

### Tilting sunroof

To tilt up, first close the sunroof, then press and hold the "TILT UP" side of the tilt switch. To tilt down the sunroof, press and hold the "TILT DOWN" side.

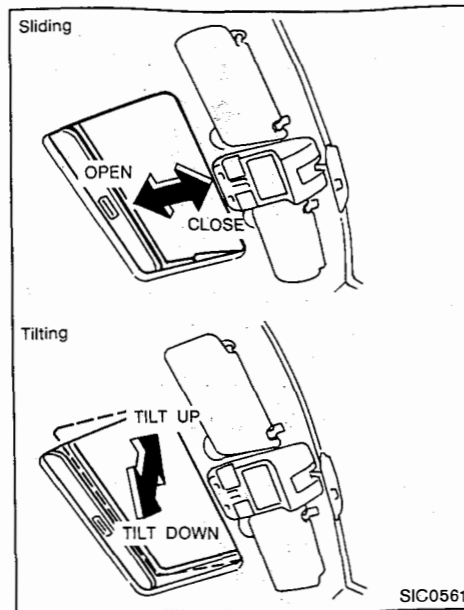

### Sunshade

Open/close the sunshade by sliding it backward/forward.

The shade will open automatically when the sunroof is opened. However, it must be closed manually.

### WARNING:

- Be extremely careful not to have any part of your body in the sunroof opening while it is closing.
- Do not stand up or extend any portion of your body out of the opening while driving.
- Remove water drops, snow, ice or sand from the sunroof before opening.
- Do not place any heavy object on the sunroof or surrounding area.

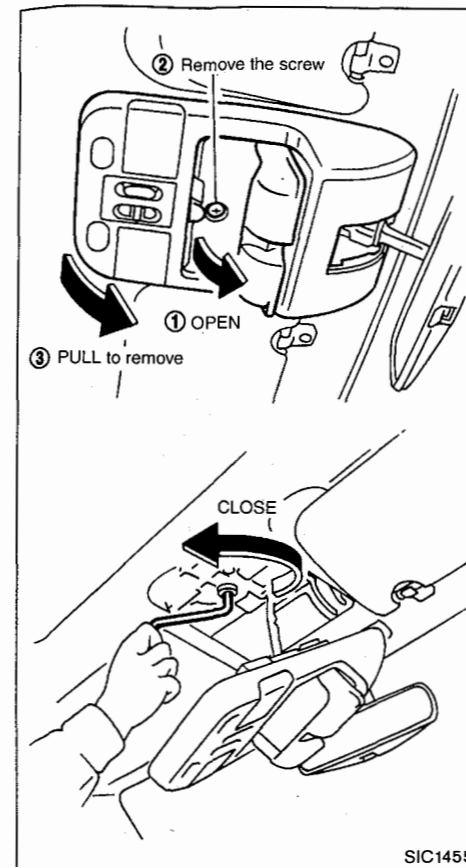

If the sunroof does not close

### WARNING:

Turn the ignition switch to the OFF position.

1. Remove the sunroof unit (1 - 3). The shaft end of the sunroof motor will be visible.
2. Using the wrench supplied in the tool bag, turn the shaft counterclockwise to close the sunroof.

If the sunroof does not tilt down, turn the shaft clockwise to tilt the sunroof down.

Have the sunroof system checked and repaired by a NISSAN dealer.

## INTERIOR LIGHTS

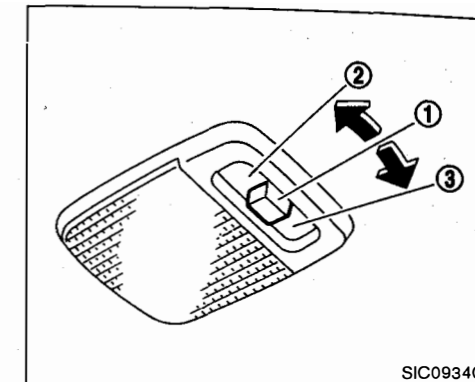

Wagon and Hardtop

### ROOM LIGHT

The room light has a three-position switch. (1) ○ or DOOR, (2) OFF, (3) ON)

When the switch is in the ○ (Wagon and Hardtop) or DOOR (Pickup) position, the light will illuminate when a door is opened.

### Room light timer (if so equipped)

The room light will stay on for about 20 seconds when:

- The key is removed from the ignition switch while the driver's door is closed.
- The driver's door is unlocked while the key is removed from the ignition switch.

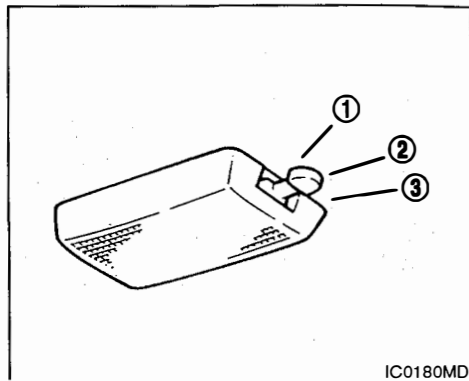

IC0180MD

Pickup

- The key is removed from the ignition switch and the driver's door is opened and then closed.

The timer is cancelled, and the room light will turn off when:

- The driver's door is locked.
- The ignition switch is turned "ON".

**CAUTION:**

Leaving the room light switch in the ON position for extended periods of time will result in a discharged battery.

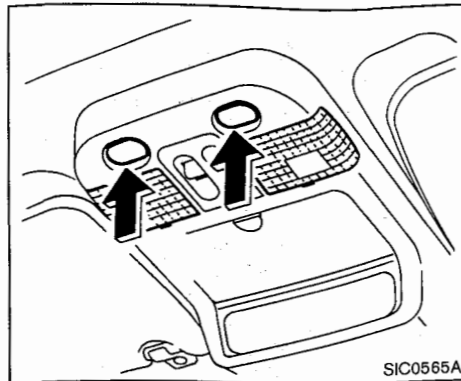

SIC0565A

**PERSONAL LIGHT (if so equipped)**

To turn on the light, push the switch. Push it again to turn off the light.

**CAUTION:**

- Turn off the lights when you leave the vehicle.
- Do not use the lights for extended periods of time with the engine stopped. This could result in a discharged battery.

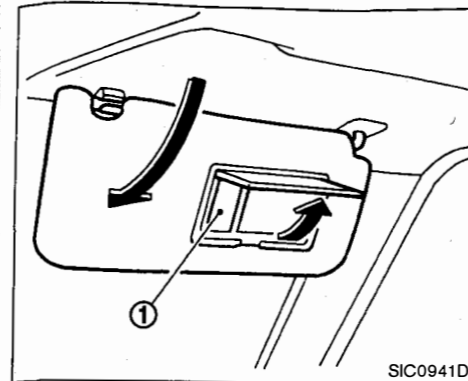

SIC0941D

Type A

**VANITY MIRROR LIGHT (if so equipped)**

The light ① on the vanity mirror will turn on when the cover on the vanity mirror is opened.

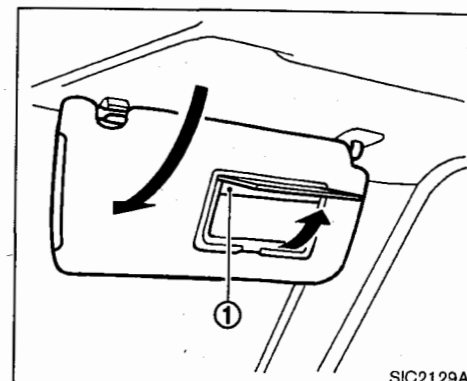

SIC2129A

Type B

### 3 Pre-driving checks and adjustments

Keys .....	3-2	Back door (Wagon and Hardtop models) .....	3-17
NISSAN Anti-Theft System (NATS) .....	3-3	Opening back door .....	3-18
Door locks .....	3-4	Locking back door .....	3-18
Super lock system .....	3-4	Child safety back door lock .....	3-19
Locking with key .....	3-5	Tonneau cover .....	3-19
Locking with inside lock knob .....	3-6	Cargo net .....	3-21
Locking with power door lock switch .....	3-7	Hooks .....	3-21
Child safety rear door lock (for Wagon models) ...	3-8	Luggage side finisher hook .....	3-21
Remote keyless entry system .....	3-8	Luggage hooks .....	3-22
Using remote keyless entry system (Type A) .....	3-9	Roof rack .....	3-23
Using remote keyless entry system (Type B) .....	3-9	Tailgate (Pickup models) .....	3-23
Integrated key fob/remote control system .....	3-10	Parking brake .....	3-24
Using integrated keyfob/remote control system....	3-11	Lever type .....	3-24
Security system .....	3-12	Steering wheel .....	3-24
Theft warning .....	3-12	Tilt operation .....	3-24
NISSAN Anti-Theft System (NATS) .....	3-13	Sun visors .....	3-25
Hood .....	3-15	Double sun visor .....	3-25
Fuel filler lid .....	3-15	Mirrors .....	3-25
Opening fuel filler lid .....	3-15	Inside rearview mirror .....	3-25
Fuel filler cap .....	3-16	Outside rearview mirrors .....	3-26
Fuel filler cap (Pickup models) .....	3-17		

## KEYS

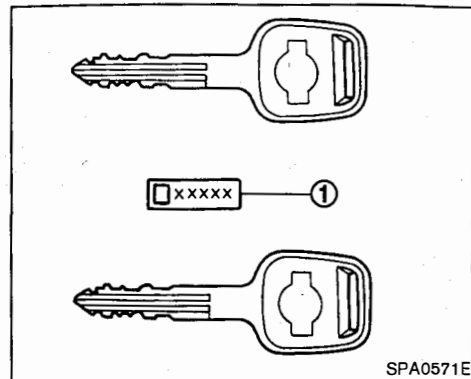

Type A

The key can only be inserted fully in the ignition key cylinder. For the door key cylinder, it is normal for the key not to go into the key cylinder all the way.

Record the key number on the key number plate/metal tag ① and keep it in a safe place (such as your wallet), NOT IN THE CAR. A key number plate is supplied with your key. Keep the plate in a safe place. NISSAN does not record key numbers so it is very important to keep track of your key number plate.

A key number is only necessary when you have lost all keys and do not have one to duplicate from. If you still have a key, this key can be duplicated by a NISSAN dealer.

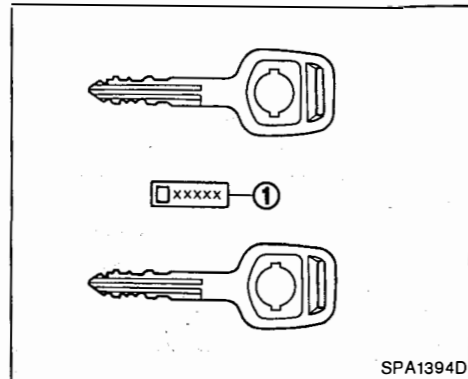

Type B

### CAUTION:

**Do not leave the keys inside the vehicle if you leave the vehicle.**

For NATS key

Record the key number shown on the tag on the last page of this manual and keep it in a safe place, NOT IN THE VEHICLE. If you lose your keys, see a NISSAN dealer for duplicates by using the key number.

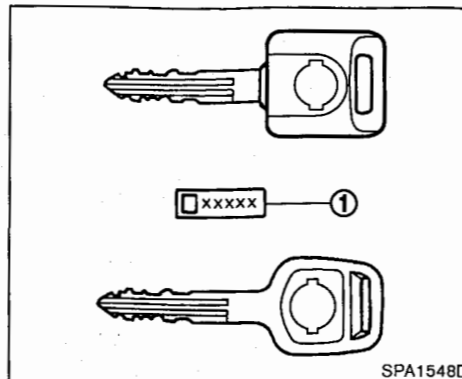

Type C

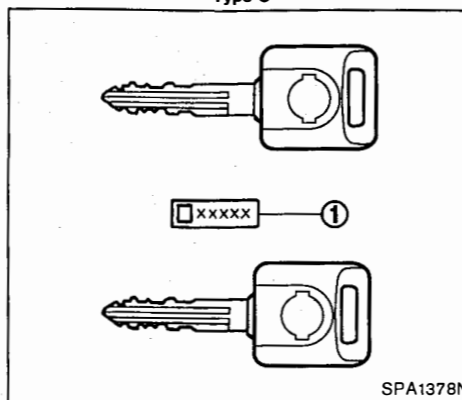

Type D

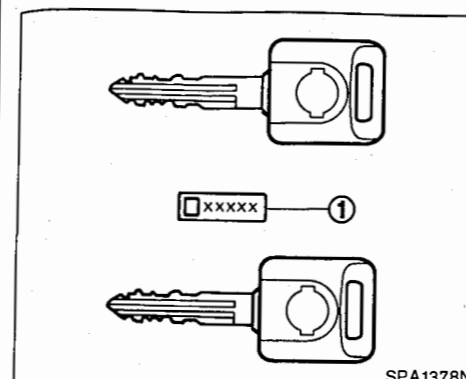

NATS equipped model — Type A

### NISSAN ANTI-THEFT SYSTEM (NATS)\* (if so equipped)

Only the key of NATS can drive your vehicle. A key number is necessary when you need extra key of NATS. As many as 4 keys or 5 keys of NATS can be registered and used with one vehicle, depending on the type of engine and/or key. The new key must be registered to the NATS components of your vehicle by a NISSAN dealer. At this time, you are requested to bring all NATS keys that you have to a NISSAN dealer.

This is because the registration process will erase all memory of the NATS components.

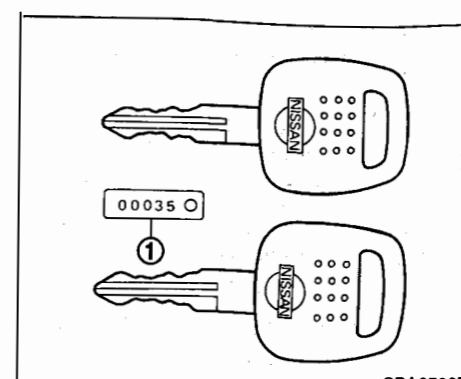

NATS equipped model — Type B

### CAUTION:

**Do not allow the NATS key, which contains an electrical transponder, to come into contact with salt water. This could cause the system to malfunction.**

\*Immobilizer

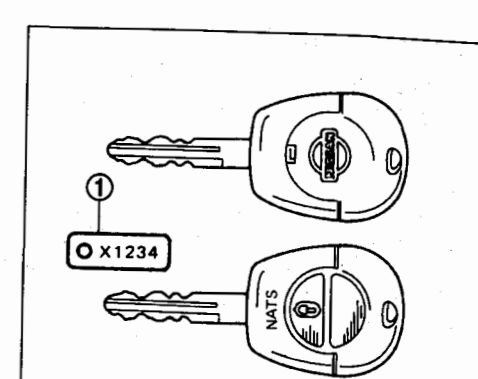

NATS equipped model — Type C

## DOOR LOCKS



### WARNING:

- Always look before opening any doors, to avoid an accident with oncoming traffic.
- Never leave children or adults who would normally require the support of others alone in the vehicle. They could unknowingly activate switches or controls and inadvertently become involved in a serious accident.

### SUPER LOCK SYSTEM (if so equipped)



### WARNING:

For Super Lock System equipped models, failure to follow the precautions below may lead to hazardous situations. Make sure the Super Lock System activation is always safely conducted.

- When the vehicle is occupied, never lock the doors with the remote controller. Doing so will trap the occupants, since the Super Lock System prevents the doors from being opened from the inside of the vehicle.
- Only operate the remote controller lock button when there is a clear view of the vehicle. This is to prevent anybody from

being trapped inside the vehicle through the Super Lock System activation.

Locking the doors with the key or the remote controller will lock all doors including the back door and activate the Super Lock System.

This means that none of the doors can be opened from the inside in order to prevent theft.

The system will be released when the door is unlocked with the key or the remote controller.

The Super Lock System will not activate when:

- The doors are locked with the power door lock switch.
- The doors are locked with the key in the ignition switch.
- The doors are locked with the inside lock knob.

### Discharged battery

The front doors can be unlocked with the door key when the vehicle battery is completely discharged. After recharging or replacing the battery, you should release (initialize) the Super Lock System by:

- turning the ignition switch to the "ON" position.
- unlocking the door from the outside of the

vehicle with the key or the remote controller (if so equipped).

### Emergency situations

If the Super Lock System is activated due to a traffic accident or other unexpected circumstances while you are in the vehicle:

- Turn the ignition switch to the "ON" position, the Super Lock System will be released and all the doors can be unlocked. You can then open the doors.
- Remove the key from the ignition switch and unlock the door using the remote controller. The Super Lock System will be released and you can open the door.
- Open or break the front door window, insert the key into the door key cylinder and unlock the door. The Super Lock System will be released and you can open the door.

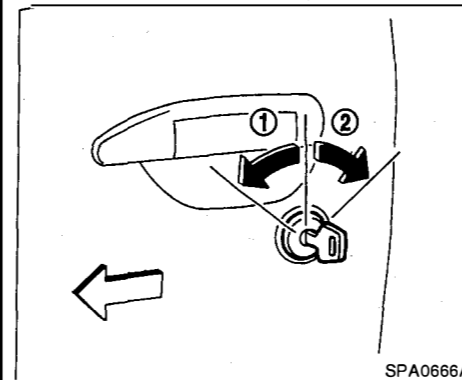

### LOCKING WITH KEY

To lock the door, turn the key towards the front of the vehicle ①. To unlock, turn it towards the rear ②.

### Model without Super Lock System

#### Type A:

Locking or unlocking the driver's door will simultaneously lock or unlock all doors including the back door.

#### Type B:

Locking or unlocking the driver's or front passenger's door will simultaneously lock or unlock all doors including the back door.

#### Type C:

Locking or unlocking the driver's or front passenger's door will lock or unlock all doors including the back door.

- Turning the front (driver's or passenger's) door key to the front of the vehicle will lock all doors.
- Turning the front door key one time to the rear of the vehicle will unlock the corresponding door. From that position, returning the key to neutral (where the key can only be removed and inserted.) and turning it to the rear again within 5 seconds will unlock all doors.

#### Type D:

Locking or unlocking the driver's or front passenger's door will lock or unlock the corresponding door. To lock or unlock the other doors, use the inside lock knob or power door lock switch.

### Model with Super Lock System

Locking or unlocking the driver's or front passenger's door will lock or unlock all doors including the back door.

- Turning the front (driver's or passenger's) door key to the front of the vehicle will lock all doors.
- Turning the front door key one time to the rear

of the vehicle will unlock the corresponding door. From that position, returning the key to neutral (where the key can only be removed and inserted.) and turning it to the rear again within 5 seconds will unlock all doors.

Locking all of the doors with the key will activate the Super Lock System. This means, none of the doors can be operated from the inside to prevent theft. The system will be released when a front door is unlocked with the key. **Be sure to turn the key as far to the right or left as possible when activating or de-activating the system.**

### CAUTION:

- **Never lock the doors from the outside with the key when the vehicle is occupied. Doing so will trap the vehicle occupants since the Super Lock System prevents the doors from being opened from the inside.**

- **Also, note that the Super Lock System will be activated if you turn the door key to the LOCK position (i.e. towards the front of the vehicle) when the door is open and then close the door behind you as you get into the vehicle. Should this situation occur, you can release the Super Lock System and open the doors from inside by turning the ignition**

switch to the ON position.

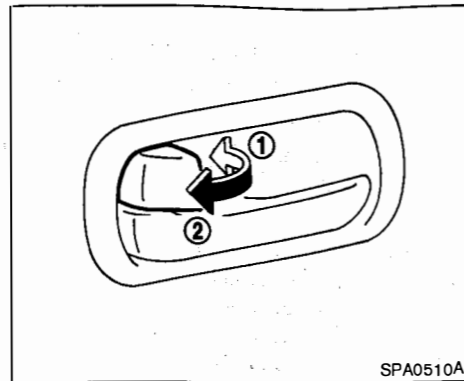

Wagon and Hardtop model

### LOCKING WITH INSIDE LOCK KNOB

To lock the door, turn the inside lock knob toward the front of the vehicle ①. To unlock, turn the knob toward the rear of the vehicle ②.

#### Model without Super Lock System

##### Driver side door — Type A:

To lock from the outside without a key, move the inside lock knob to the LOCK position. Then close the door while holding the outside door handle up.

##### Driver side door — Type B:

The driver side door can only be locked from the outside by using the key or the remote controller (if so equipped).

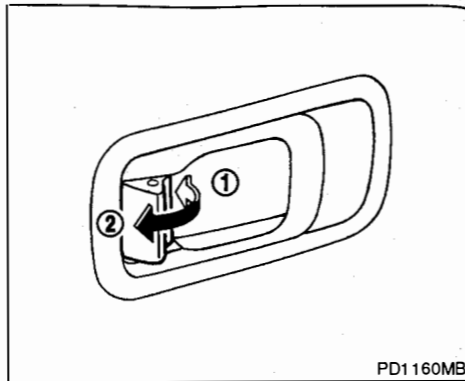

Pickup model

#### Other doors:

To lock the other doors from the outside without using the key, move the inside lock knob to the LOCK position, then close the door.

#### Model with Super Lock System

To lock from the outside without a key, move the inside lock knob to the LOCK position, then close the door. This method will lock the doors, but will not activate the Super Lock System.

**When locking the doors this way, be careful not to leave the key inside the vehicle. The driver's door inside lock knob cannot be set to the LOCK position with any door open and with the key in the ignition switch to remind the driver the key is still in the**

ignition switch.

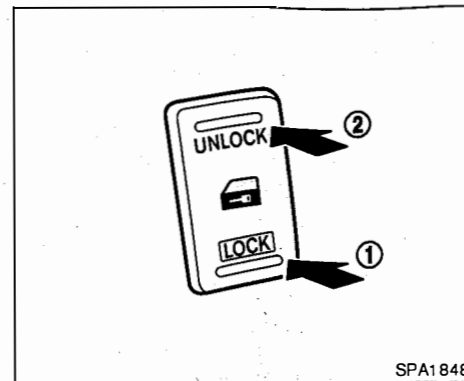

SPA184B

Switch location — on the console box

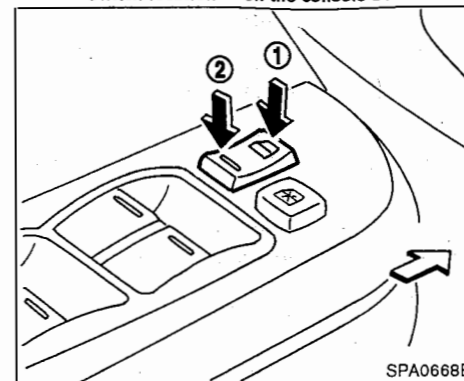

SPA0668E

Switch location — on the driver's armrest

### LOCKING WITH POWER DOOR LOCK SWITCH (if so equipped)

The shape and location of the switch differs with models.

When the Super Lock System (if so equipped) is activated, it is not possible to lock or unlock doors with the power door lock switch.

#### Type A

Operating the power door lock switch will lock ① or unlock ② all doors and the back door except the driver side door.

#### Type B

Operating the power door lock switch will lock ① or unlock ② all doors and the back door.



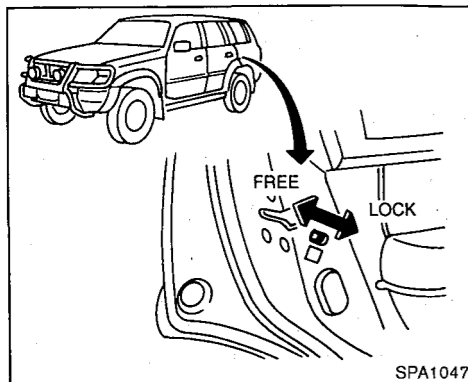

SPA1047

### CHILD SAFETY REAR DOOR LOCK (for Wagon models)

Child safety locking helps prevent doors from being opened accidentally, especially when small children are in the vehicle.

When the lever is in the LOCK position, the rear door can be opened only from the outside.

### REMOTE KEYLESS ENTRY SYSTEM (if so equipped)

It is possible to lock/unlock all doors including the back door and to activate the panic alarm (Type B only) by using the remote controller from outside the vehicle.

**Be sure to remove the key from the vehicle before locking the doors and leaving it.**

The remote controller can operate at a distance of approximately 1 m (3.3 ft) from the vehicle. (The effective distance depends upon the conditions around the vehicle.)

As many as four remote controllers can be used with one vehicle. For information concerning the purchase and use of additional remote controllers, contact a NISSAN dealer.

**The remote controller will not function when:**

- the key is inserted into the ignition switch.
- the battery in the remote controller is dead.
- the distance between the remote controller and vehicle is more than approx. 1 m (3.3 ft).

#### CAUTION:

Listed below are conditions or occurrences which will damage the remote controller.

- Do not allow the remote controller to become wet.

- Do not drop the remote controller.
- Do not strike the remote controller sharply against another object.
- Do not place the remote controller for an extended period in an area where temperatures exceed 60°C (140°F).

**If a remote controller is lost or stolen, NISSAN recommends erasing the ID code of that controller. This will prevent the controller from unauthorized use to unlock the vehicle. For information regarding the erasing procedure, contact a NISSAN dealer.**

For information regarding the replacement of a battery, see "Battery" in the "8. Maintenance and do-it-yourself" section.

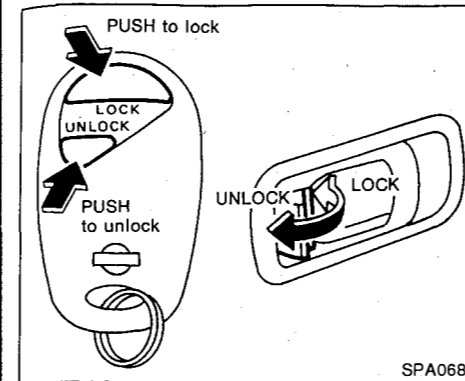

### USING REMOTE KEYLESS ENTRY SYSTEM (Type A)

#### Locking doors

1. Remove the ignition key.
2. Close all the doors.
3. Push the LOCK button on the remote controller.
4. The hazard indicators flash once.
5. All the doors will lock.

#### Unlocking doors

1. Push the UNLOCK button on the remote controller.

2. The hazard indicators flash twice.
3. All doors will unlock.
4. The room light will stay on for about 20 seconds when the room light switch is in the center "O" position.

The room light can be turned off without waiting for about 20 seconds by inserting the key into the ignition or by locking the doors with the remote controller or by pushing the room light button.

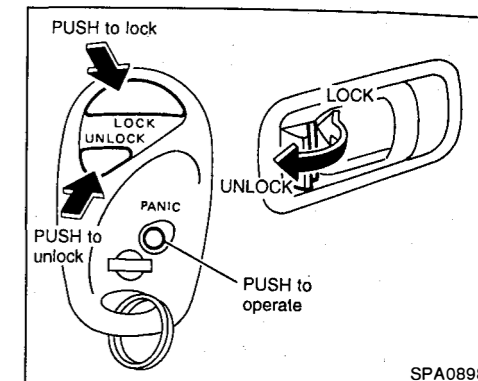

### USING REMOTE KEYLESS ENTRY SYSTEM (Type B)

#### Locking doors

1. Remove the ignition key.
2. Close all of the doors.
3. Push the LOCK button on the remote controller.
4. The hazard indicators flash twice.
5. All of the doors will lock.

Although door locking with the remote controller can be confirmed by looking at the hazard indicator, always check to be sure that the doors are properly locked before leaving your vehicle.

### Unlocking doors

1. Push the UNLOCK button on the remote controller.
  - Only the driver's door unlocks.
  - The hazard indicators flash once.
  - The room light will stay on for 30 seconds when the room light switch is in the center ○ position.
2. Push the UNLOCK button on the remote controller again within 5 seconds.
  - All doors unlock.
  - The hazard indicators flash once.

The room light can be turned off without waiting for 30 seconds by turning the ignition switch to the ON position or by locking the doors with the remote controller.

### Using panic alarm

If you are near your vehicle and feel threatened, you may activate the alarm to call attention as follows:

1. Push the PANIC button on the remote controller for **longer than 0.5 second**.
2. The theft warning alarm and headlights will stay on for about 30 seconds.

3. The panic alarm stops when:
  - It has run for about 30 seconds, or
  - The LOCK or UNLOCK button is pressed, or
  - The PANIC button is pushed on the remote controller for longer than 0.5 second.

### INTEGRATED KEY FOB/REMOTE CONTROL SYSTEM (if so equipped)

All doors can be locked/unlocked from the outside by pressing the LOCK/UNLOCK button on the integrated keyfob.

The remote controller can operate at a distance of approximately 1 m (3.3 ft) from the vehicle. (The effective distance depends upon the conditions around the vehicle.)

As many as four remote controllers can be used with one vehicle. For information concerning the purchase and use of additional remote controllers, contact a NISSAN dealer.

#### CAUTION:

- **Always remove the ignition key, close all windows and the sunroof before operating the system.**
- **Ensure that the driver's door is securely closed before operating the remote control door lock system, to ensure correct operation of the system.**

Listed below are conditions or occurrences which will damage the remote controller.

- **Do not allow the remote controller to become wet.**
- **Do not drop the remote controller.**
- **Do not strike the remote controller sharply against another object.**

- **Do not place the remote controller for an extended period in an area where temperatures exceed 60°C (140°F).**

If a remote controller is lost or stolen, NISSAN recommends erasing the ID code of that controller. This will prevent the controller from unauthorized use to unlock the vehicle. For information regarding the erasing procedure, contact a NISSAN dealer.

If your vehicle is equipped with a genuine NISSAN anti-theft system, operating the remote control door lock system will simultaneously operate the anti-theft system.

For information regarding the replacement of a battery, see "Battery" in the "8. Maintenance and do-it-yourself" section.

### USING INTEGRATED KEYFOB/REMOTE CONTROL SYSTEM



#### WARNING:

For Super Lock System equipped models, failure to follow the precautions below may lead to hazardous situations. Make sure the Super Lock System activation is always safely conducted.

- **When the vehicle is occupied, never lock the doors with the remote controller. Doing so will trap the occupants, since the Super Lock System prevents the doors from being opened from the inside of the vehicle.**
- **Only operate the remote controller lock button when there is a clear view of the vehicle. This is to prevent anybody from being trapped inside the vehicle through the Super Lock System activation.**

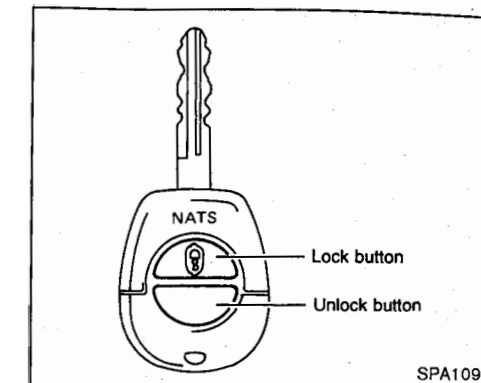

### Locking doors

1. Remove the ignition key.
2. Close all the doors.
3. Push the LOCK button on the remote controller.
4. The hazard indicators flash once.
5. All the doors will lock.

**All of the doors will lock when the LOCK button on the remote controller is pushed even if the key is in the ignition switch. However, the super lock system (if so equipped) does not activate.**

- When the LOCK button is pushed with all

doors locked, the hazard indicator flashes once as a reminder that the doors are already locked.

### Unlocking doors

#### Type A:

1. Push the UNLOCK button on the remote controller once.

- Only the driver's door unlocks
- The hazard indicators flash twice.

2. Push the UNLOCK button on the remote controller again within 5 seconds.

- All doors unlock
- The hazard indicators flash twice.

#### Type B:

1. Push the UNLOCK button on the remote controller.

2. The hazard indicators flash twice.

3. All doors will unlock.

## SECURITY SYSTEM (if so equipped)

Your vehicle has one or both of the following security systems:

- Theft warning
- NISSAN Anti-Theft System (NATS)\* (\* immobilizer)

The security condition will be shown by the security indicator light.

### THEFT WARNING

The theft warning system provides visual and audio alarm signals if parts of the vehicle are disturbed.

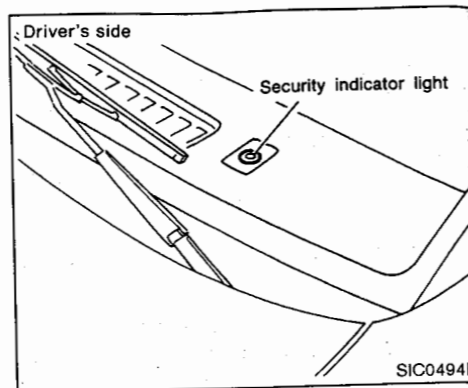

### Security indicator light

This light blinks whenever the ignition switch is in the LOCK, OFF or ACC position. This function indicates the security systems equipped on the vehicle are operational.

### How to activate the theft warning system

1. Close all windows.

**The system can be activated even if the windows are open.**

2. Remove the key from the ignition switch.

3. Close and lock all doors, hood and back door. Lock all doors by the key or pressing

the LOCK button on the remote controller (if so equipped).

4. Confirm that the security indicator light comes on. The light glows for about 30 seconds and then blink. The system is now activated. If, during this 30 second time period, the door is unlocked by the key or the remote controller, or the ignition switch is turned to ACC or ON, the system will not activate.

### CAUTION:

- **If the key is turned slowly toward the front of the vehicle when locking the door, the system may not activate. If the key is returned beyond the vertical position toward the rear of the vehicle to remove the key, the system may be deactivated. If the indicator light fails to glow for 30 seconds, unlock the door once and lock it again.**

- **Even when the driver and/or passengers are in the vehicle, the system will activate with all doors locked and ignition key off. Turn the ignition switch to ACC to turn the system off.**

### Theft warning system activation

The warning system will give the following alarm:

- The headlights blink and the horn sounds intermittently.

- The alarm automatically turns off after 2 to 3 minutes. However, the alarm reactivates if the vehicle is tampered with again.

The alarm is activated by:

- Unlocking the door or back door without using the key or remote controller. (Even if the door is opened by releasing the door inside lock knob, the alarm is activated.)

- Connecting the battery connector after it has been disconnected from battery for more than 1 second.

- Opening the hood. (Even if the hood is opened by the hood release handle, the alarm is activated.) — if so designed

### How to stop alarm

The alarm will stop only by unlocking a door or back door with the key or by pressing the UNLOCK button on the remote controller. The alarm will not stop if the ignition switch is turned to ACC or ON.

**If the system does not operate as described above, have it checked by a NISSAN dealer.**

## NISSAN ANTI-THEFT SYSTEM (NATS)

The NISSAN Anti-Theft System (NATS)\* will not allow the engine to start without the use of the registered NATS key.

\*Immobilizer

If the engine fails to start using the registered NATS key, it may be due to interference caused by another NATS key, an automated toll road device or automated payment device on the key ring. Restart the engine using the following procedures:

(Except for TD42/TD42Ti engine models):

1. Leave the ignition switch in the ON position for approximately 5 seconds.

2. Turn the ignition switch to the OFF or LOCK position and wait approximately 5 seconds.

3. Repeat step 1 and 2 again.

4. Restart the engine while holding the device (which may have caused the interference) separate from the registered NATS key.

(For TD42/TD42Ti engine models):

1. Turn the ignition switch to OFF.

2. Wait for 1 minute. The security indicator light will blink.

3. Turn the ignition switch to ON with a registered key. Do not start engine. Wait for 5 seconds.
4. Return the ignition switch to OFF.
5. Repeat steps (3) and (4) twice (total of three cycles).
6. Start the engine.

If this procedure allows the engine to start, NISSAN recommends placing the registered NATS key on a separate key ring to avoid interference from other devices.

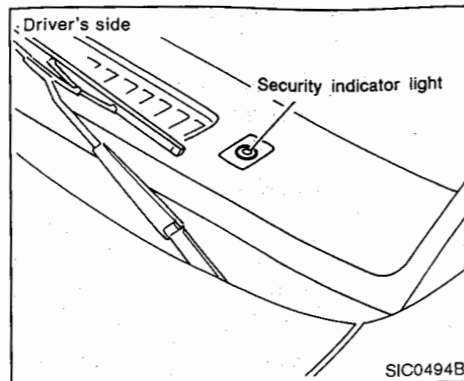

#### Security indicator light

This light blinks whenever the ignition switch is in the LOCK, OFF or ACC position. This function indicates the NATS (NISSAN Anti-Theft System)\* equipped on the vehicle is operational.

#### \*Immobilizer

If NATS is malfunctioning, this light will remain on while the ignition switch is in the ON position.

#### RHD models for Europe:

If NATS is malfunctioning, this light will turn on after flashing six times while the ignition switch is in the ON position.

However, if the security indicator light turns off after the light has remained on for 15 minutes,

you can start the engine only once. See a NISSAN dealer for NATS service as soon as possible.

**If the light still remains on and/or the engine will not start, see a NISSAN dealer for NATS service as soon as possible. Bring all NATS keys that you have when visiting a NISSAN dealer for service.**

## HOOD

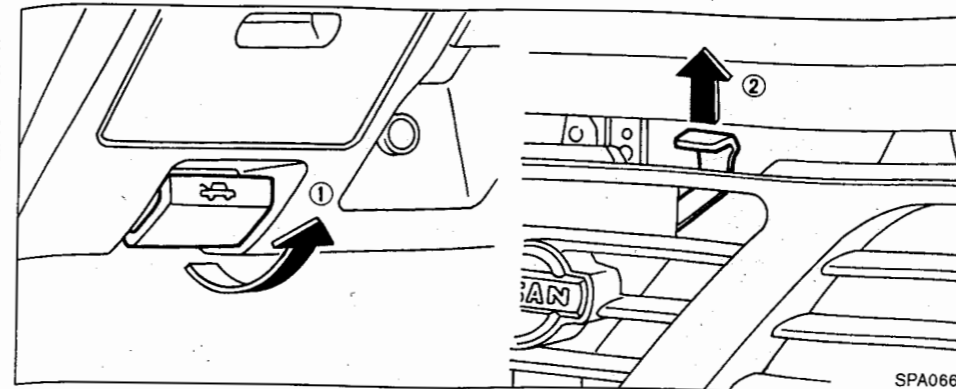

1. Pull the hood lock release handle ① located below the instrument panel; the hood will then spring up slightly.
2. Push the lever ② at the front of the hood with your fingertips and raise the hood.
3. When closing the hood, slowly close the hood and make sure it locks into place.

#### WARNING:

**Always check that the hood is closed and locked securely to prevent it from opening while driving. The vehicle should only ever be operated with the hood securely closed.**

## FUEL FILLER LID

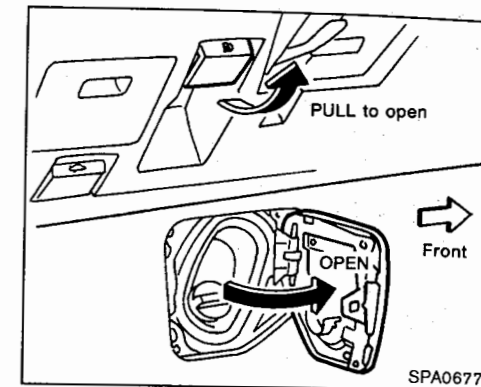

#### OPENING FUEL FILLER LID

To open the fuel filler lid, pull up the opener lever. To lock, close the fuel filler lid securely.

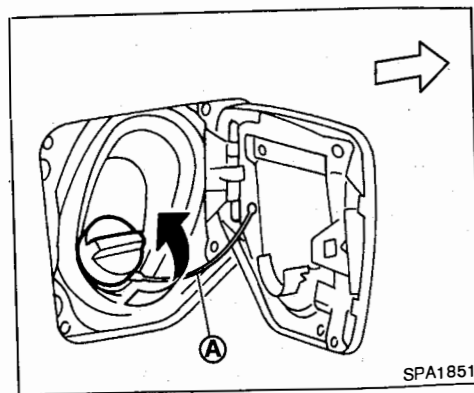

### FUEL FILLER CAP

The fuel filler cap is a ratcheting type. Tighten the cap clockwise until ratcheting clicks are heard.

The fuel filler cap is connected to the fuel filler lid with the tether **A** (if so equipped).

#### CAUTION:

- Fuel is extremely flammable and highly explosive under certain conditions. Always stop engine and do not smoke or allow open flames or sparks near the vehicle when refueling.
- Fuel may be under pressure. Turn the cap one-half turn and wait for any "hissing" sound to stop, to prevent fuel

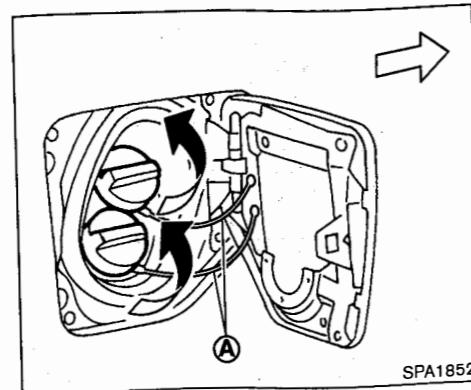

Model with sub tank

from spraying out and possible personal injury. Then remove the cap.

- Use only a genuine NISSAN fuel filler cap as a replacement. It has a built-in safety valve needed for proper operation of the fuel system and emission control system. An incorrect cap can result in a serious malfunction and possible injury.
- If fuel is spilled on the vehicle body, flush it away with water to avoid paint damage.

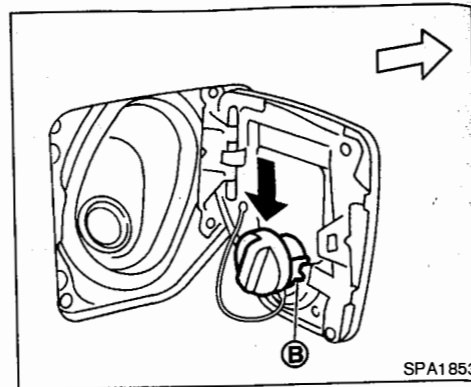

Put the fuel filler cap on the cap holder **B** while refueling.

### FUEL FILLER CAP (Pickup models)

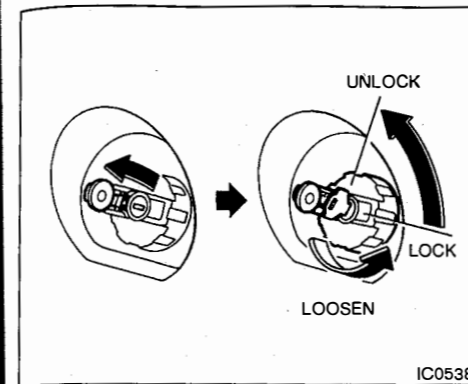

To open the fuel filler cap, turn the key counter-clockwise.

The fuel filler cap is a ratcheting type. Tighten the cap clockwise until ratcheting clicks are heard. The cap will lock automatically.

For models equipped with a sub tank, the main tank is located on the rear side.

#### CAUTION:

- Fuel is extremely flammable and highly explosive under certain conditions. Always stop engine and do not smoke or allow open flames or sparks near the vehicle when refueling.
- Fuel may be under pressure. Turn the

cap one-half turn and wait for any "hissing" sound to stop, to prevent fuel from spraying out and possible personal injury. Then remove the cap.

- Use only a genuine NISSAN fuel filler cap when replacing it. It has a built-in safety valve needed for proper operation of the fuel system and emission control system. An incorrect cap can result in a serious malfunction and possible injury.
- If fuel is spilled on the vehicle body, flush it away with water to avoid paint damage.

### BACK DOOR (Wagon and Hardtop models)

#### WARNING:

- Always check that the back door has been closed securely to prevent it from opening while driving.
- Do not drive with the back door open. This could allow dangerous exhaust gases to be drawn into the vehicle.

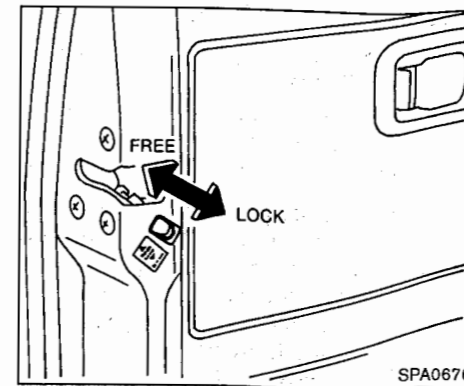
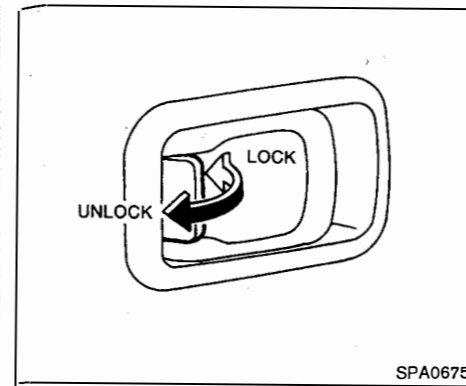
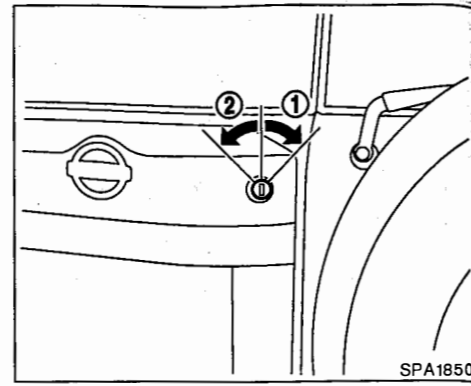
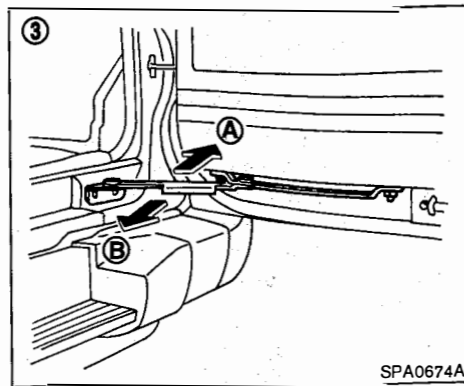
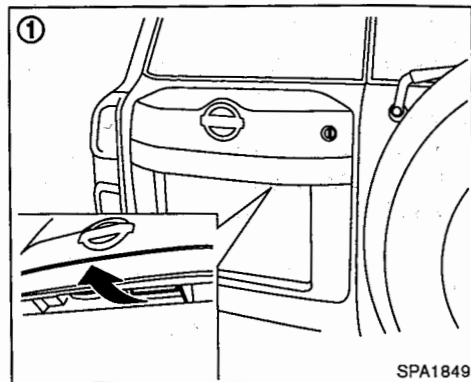

**TONNEAU COVER (if so equipped)**

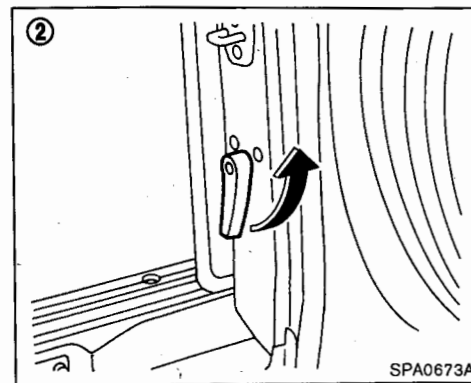
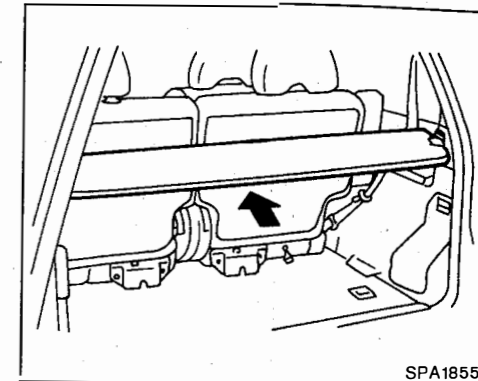

**OPENING BACK DOOR**

1. Pull the opener handle to open the left side back door.
2. To open the right side back door, pull the lever located on the lower side of it.
3. Push the back door stay forward **A** to secure the opened door. To release, pull the stay toward you **B**.

**LOCKING BACK DOOR**

**Locking with key**

Turn the key clockwise **1** to lock the back door. To unlock, turn the key counterclockwise **2**.

**Power door lock system (if so equipped):**

- Turning the back door key clockwise will lock all doors.
- Turning the back door key one time counterclockwise will unlock the back door. From that position, returning the key to neutral (where the key can only be removed and inserted.) and turning it counterclockwise again within 5 seconds will unlock all doors.

**Locking with inside lock knob (if so equipped)**

To lock from the outside without a key, push the lock knob, then close the back door securely.

**CHILD SAFETY BACK DOOR LOCK**

Child safety locking helps prevent doors from being opened accidentally, especially when small children are in the vehicle.

When the lever is in the LOCK position, the back door can be opened only from the outside.

**Board type**

The tonneau cover keeps the luggage compartment contents hidden from the outside.

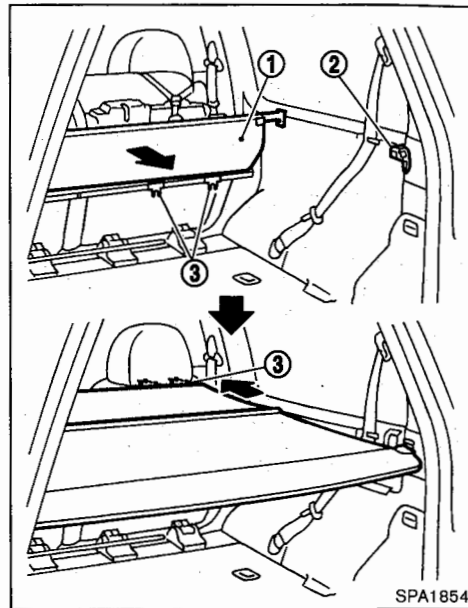

Roll type

Your vehicle is equipped with either a board type or a roll type tonneau cover. To use the roll type tonneau cover, pull it out (1) fully and fit it in the notch (2). Fit the hooks (3) in the legs of the head restraint.

**WARNING:**

- Never put anything on the tonneau

cover, no matter how small. Any object on it could cause an injury in an accident or sudden stop.

- Do not leave the tonneau cover in the vehicle with it disengaged from the holder.
- The child restraint top tether strap may be damaged by contact with the tonneau cover or items in the luggage area. Remove the tonneau cover from the vehicle or secure it in the luggage area. Also secure any items in the luggage area. Your child could be seriously injured or killed in a collision if the top tether strap is damaged.

**CARGO NET (if so equipped)**

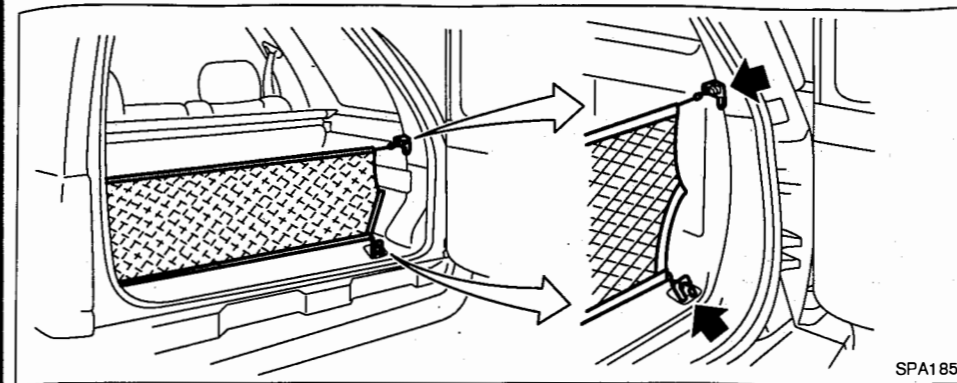

The cargo net keeps packages in the cargo area from moving around while your vehicle is driven.

To install the cargo net, attach the four hooks to the four retainers.

**WARNING:**

- Properly secure all cargo to help prevent it from sliding or shifting. Do not place cargo higher than the seatbacks. In a sudden stop or collision, unsecured cargo could cause personal injury.
- Be sure to secure all four hooks into the retainers. The cargo restrained in the net must not exceed 13.6 kg (30 lb) or the net may not stay secured.

**HOOKS (if so equipped)**

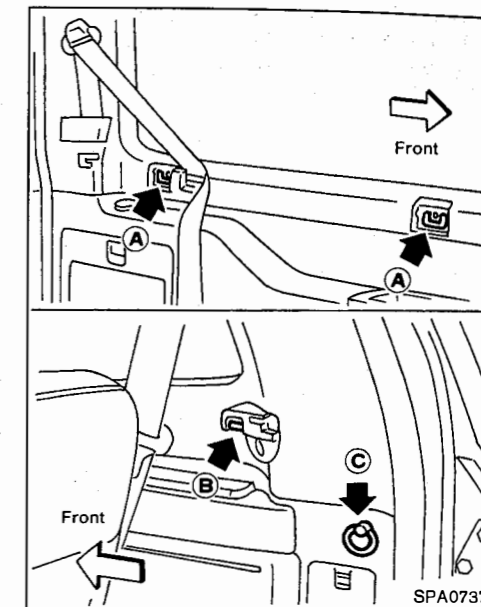

**LUGGAGE SIDE FINISHER HOOK**

**WARNING:**

- Always make sure that the luggage is properly secured. Use the suitable ropes and hooks.
- Unsecured luggage can become dangerous in an accident or sudden stop.

- When hooking on ropes, do not apply a load of more than 50 kg (110 lb) A and B, 30 kg (66 lb) C to a single hook.

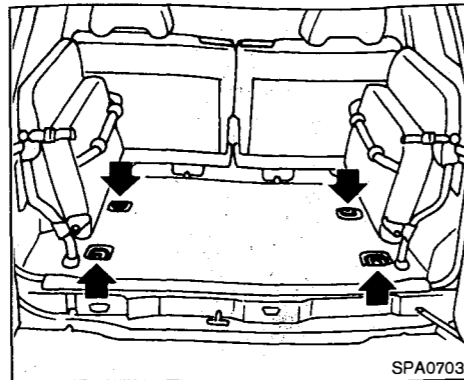

#### LUGGAGE HOOKS



#### WARNING:

- Always make sure that the luggage is properly secured. Use the suitable ropes and hooks.
- Unsecured luggage can become dangerous in an accident or sudden stop.

#### ROOF RACK (if so equipped)

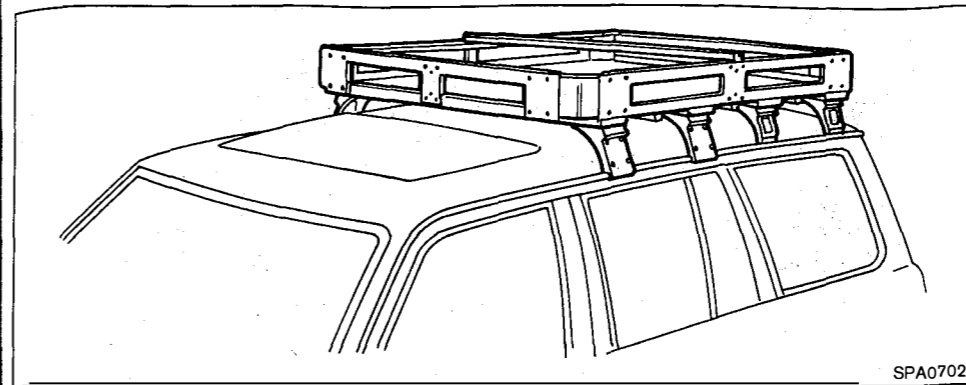

Luggage can be carried on the roof rack. The roof rack is designed to carry loads (luggage plus roof rack) below 100 kg (221 lb). Overloading may cause damage to the vehicle.

Do not allow large items to protrude from the side or rear bumper of the vehicle. The luggage should be loaded so that it does not contact the roof and scratch or damage the vehicle.

Luggage should be positioned as far forward as possible by adjusting the roof rack. This will help evenly distribute the luggage weight between the front and rear axles. Be sure to securely tighten the rope after the luggages have been adjusted. The total weight should not exceed the gross vehicle weight rating (GVWR) or the gross axle weight rating (GAWR).

The luggage should be fastened by securing the luggage to the roof rack. When driving, occasionally check that the luggage is securely fastened to prevent damage or loss of cargo. Carrying heavy or large objects on the roof will effect your handling of the vehicle. Drive the vehicle at a moderate speed.

#### TAILGATE (Pickup models) (if so equipped)

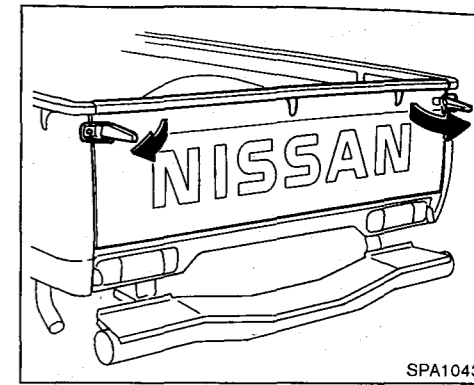

To open the tailgate, pull the tailgate levers and lower the tailgate. The support chain will hold the gate open.

- When closing the tailgate, make sure that the levers are securely locked.
- The weight of the cargo load must be evenly distributed over both the front and rear axles.
- All cargo should be securely fastened with ropes or straps to prevent it from shifting or sliding within the vehicle.



## PARKING BRAKE

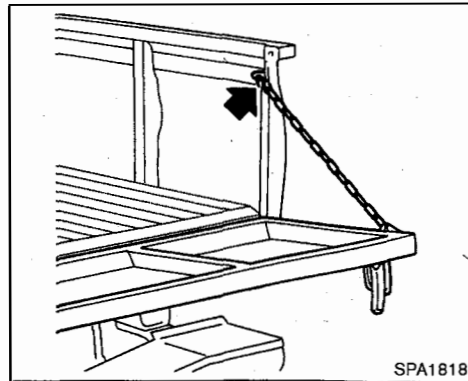

To open the tailgate down to the lowest position, lift the tailgate slightly, then release the chain. Be careful not to hit the tailgate against the rear bumper (if so equipped).

- Do not drive the vehicle with the tailgate down.
- While driving, never allow anyone to ride in the cargo area. Abrupt braking or stopping could lead to personal injury.

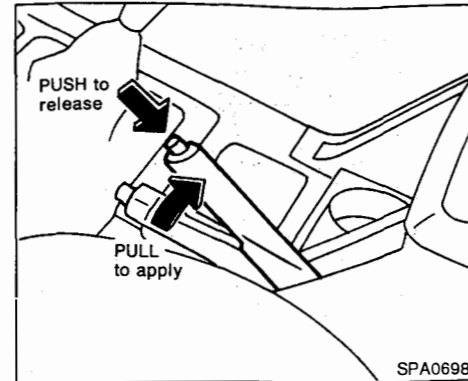

### LEVER TYPE

**To apply:** pull the lever up.

**To release:** pull the lever up slightly, push the button and lower completely. Before driving, be sure the brake warning light goes out.

## STEERING WHEEL

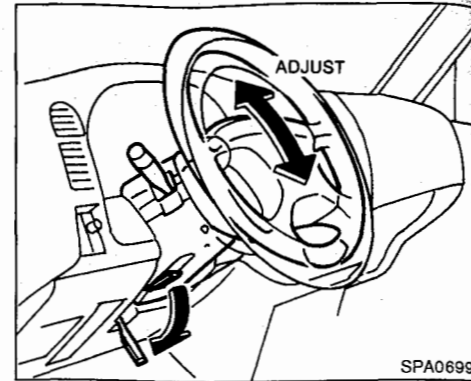

### TILT OPERATION

Push the lock lever down and adjust the steering wheel up or down to the desired position. Push the lock lever up firmly to lock the steering wheel in place.



**WARNING:**

Do not adjust the steering wheel while driving.

## SUN VISORS

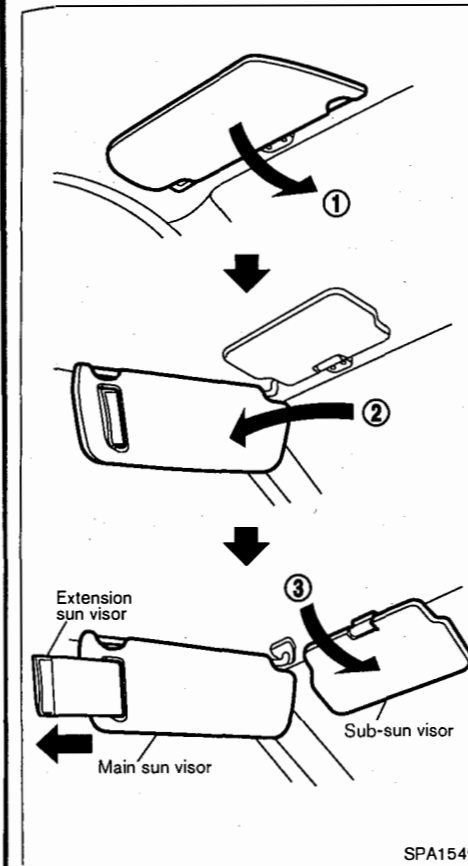

DOUBLE SUN VISOR (if so equipped)

### CAUTION:

- Do not store the main sun visor before storing the sub-sun visor and the extension sun visor.
- Do not pull the sub-sun visor or the extension sun visor forcedly downwards.

1. To block out glare from the front, swing down the main sun visor.
2. To block glare from the side, remove the main sun visor from the center mount and swing it to the side. (The main sun visor is equipped with the extension as illustrated.)
3. Then, to block glare from the front too, swing down the sub-sun visor.

## MIRRORS

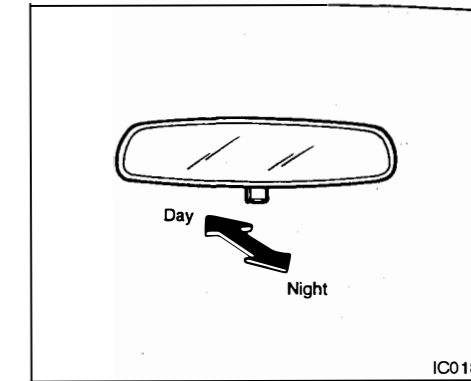

### INSIDE REARVIEW MIRROR

The night position will reduce glare from the headlights of vehicles behind you at night.

### CAUTION:

Use the night position only when necessary, because it reduces rear view clarity.

## OUTSIDE REARVIEW MIRRORS

### WARNING:

- Check the position of all mirrors before driving. Altering their position while driving could distract your attention from the driving operation.
- Objects viewed in the outside rearview mirror are closer than they appear. (if so equipped)

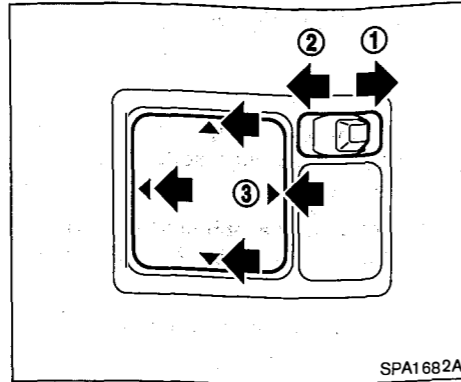

### Adjusting

#### Remote control type:

The outside rearview mirror will operate only when the ignition switch is in the ACC or ON position.

Move the switch to the right ① or left ② to select the right or left outside mirror, then adjust the mirror to the desired position by pushing the button ③.

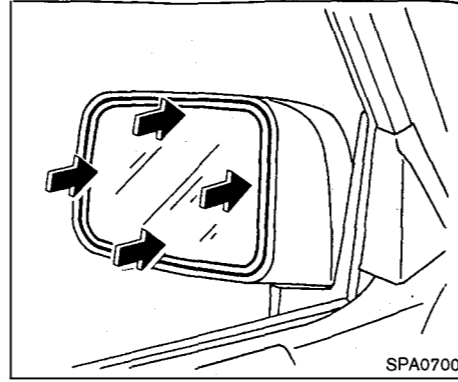

### Manual control type:

The outside rearview mirrors can be moved in any direction for a better rear view.

Push on the mirror surface directly to adjust it.

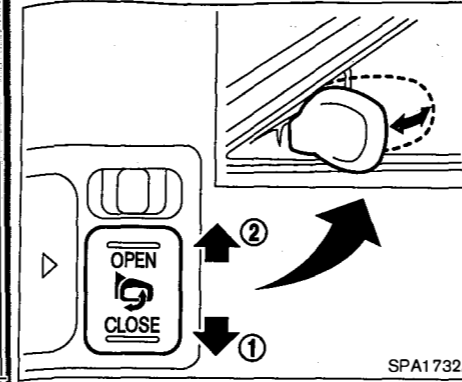

### Folding

#### Remote control type:

To fold the outside rearview mirror, push the CLOSE side ① of the switch. To return the outside rearview mirror to its original position, push the OPEN side ② of the switch.

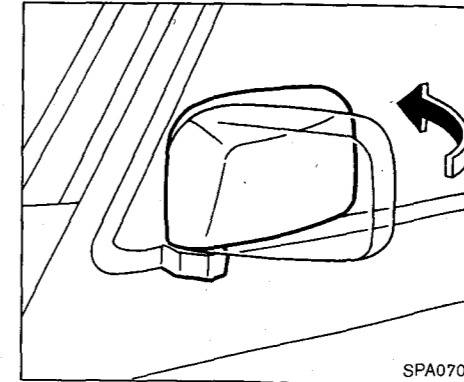

### Manual control type:

Fold the outside rearview mirror by pushing it toward the rear of the vehicle.

## 4 Display screen, heater and air conditioner, and audio system

Safety precautions.....	4-2	Audio system .....	4-15
Display screen (with navigation system).....	4-2	Audio operation precautions .....	4-15
Information menu.....	4-3	Antenna .....	4-16
Settings.....	4-4	AM radio .....	4-18
"DAY/NIGHT" button .....	4-4	FM-AM radio .....	4-19
Ventilators .....	4-5	MW-SW radio with cassette tape player .....	4-21
Front ventilators .....	4-5	FM-AM/MW-SW-FM radio with cassette tape player .....	4-23
Rear ventilators .....	4-6	FM-AM radio with cassette tape player and compact disc (CD) player .....	4-25
Air conditioner filter (ventilation air filter) .....	4-6	LW-MW-FW radio with compact disc (CD) player .....	4-31
Heater and air conditioner .....	4-6	FM-AM radio with cassette tape player and compact disc (CD) changer .....	4-37
Operating tips .....	4-6	LW-MW-FM radio with cassette tape player and compact disc (CD) changer .....	4-43
Manual air conditioner .....	4-7	Steering switch for audio control .....	4-51
Automatic air conditioner .....	4-10	Car phone or CB radio.....	4-53
Heat switch (for ZD30DDTi engine model) .....	4-12		
Rear heater .....	4-13		
Rear cooler .....	4-13		
Servicing air conditioner .....	4-14		
Cool box .....	4-14		

## SAFETY PRECAUTIONS



### WARNING:

- Do not adjust the display controls, heater and air conditioner controls or audio controls while driving so that full attention may be given to vehicle operation.
- If you noticed any foreign objects entering the system hardware, spilled liquid on the system, or noticed smoke or fumes coming out from the system, or any other unusual operation is observed, stop using the system immediately and contact the nearest NISSAN dealer. Ignoring such conditions may lead to an accident, fire or electric shock.

## DISPLAY SCREEN (with navigation system)

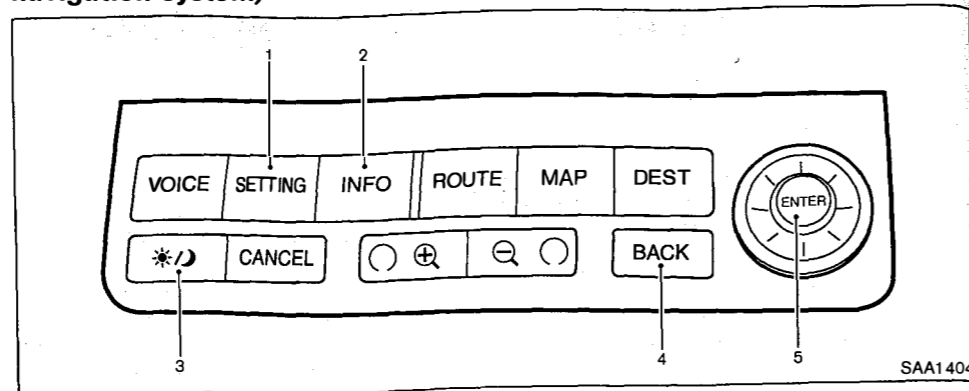

- "SETTING" button
- "INFO" (Information) button
- "DAY/NIGHT" button
- "BACK" button
- JOYSTICK and "ENTER" button

For navigation system control buttons, refer to the separate Navigation System Owner's Manual.

SAA1404

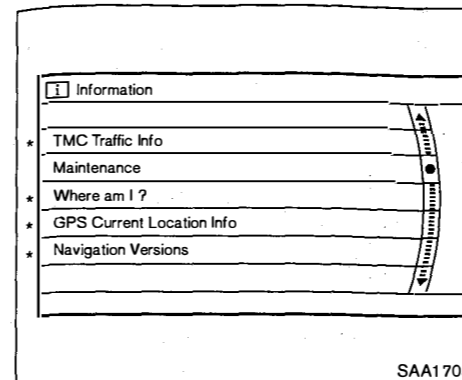

SAA1703

\*: Refer to the separate Navigation System Owner's Manual.

### INFORMATION MENU

When the "INFO" button is pushed, the information menu will display on the screen.

Choose the desired item and push the "ENTER" button for further information and settings.

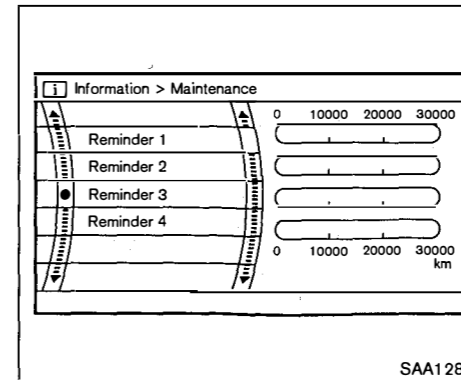

SAA1283

### Maintenance information

Choose "Maintenance" and push the "ENTER" button, and the maintenance information will be displayed on the screen.

- To set the reminder, choose "Reminder" (1 to 4) key and push the "ENTER" button.

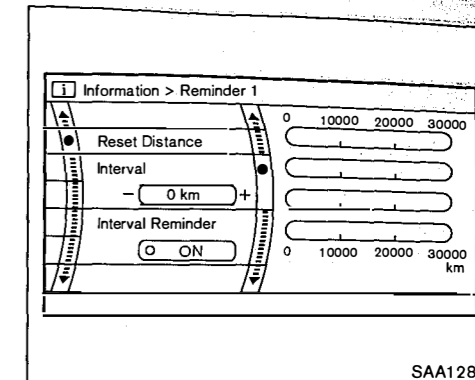

SAA1284

- Set the interval schedule (distance) by using the JOYSTICK.

- To automatically display the "MAINTENANCE INFORMATION" when it has been reached to the set distance, choose "Interval Reminder" and push the "ENTER" button. The indicator light will illuminate.

To reset the reminder schedule (distance), choose "Reset Distance" and push the "ENTER" button.

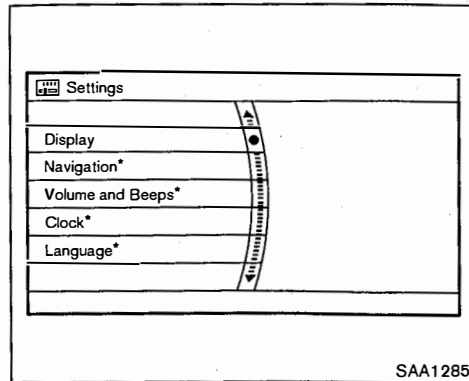

SAA1285

\*: Refer to the separate Navigation System Owner's Manual.

## SETTINGS

When the "SETTING" button is pushed, the settings display will appear on the screen.

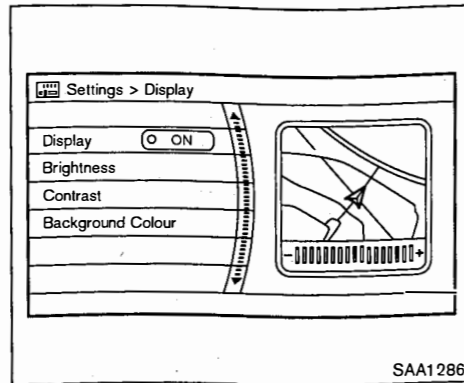

SAA1285

### Display setting

To set the display, choose "Display" and push the "ENTER" button.

#### Display on/off:

To turn off the display, push the "ENTER" button and turn the "Display" indicator off.

To turn on the display, push the "ENTER" button and turn the "Display" indicator on.

#### Brightness/Contrast/Background Colour:

To adjust the display brightness, contrast and background colour, choose the item and adjust each setting using the joystick.

### Clock:

See the separate Navigation System Owner's Manual for the clock adjustment.

### Language:

The language can be chosen from 7 languages.

See the separate Navigation System Owner's Manual for the setup.

### "DAY/NIGHT" BUTTON

To change the display brightness, push the "DAY/NIGHT" button. Pushing the button again will change the display to DAY or NIGHT display. Then, adjust the brightness by moving the joystick right or left.

If no operation is done within 10 seconds, or if the "BACK" button is pushed, the display will return to the previous display.

Pushing the "DAY/NIGHT" button for more than approximately 2 seconds will turn the display off.

## VENTILATORS

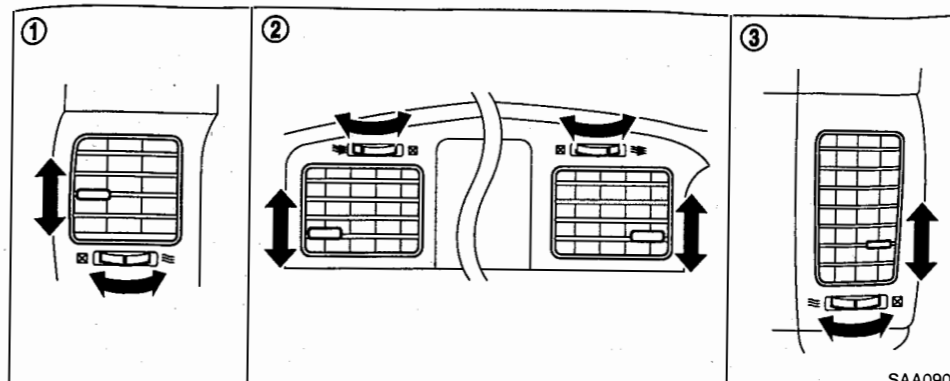

Wagon and Hardtop model

SAA0901

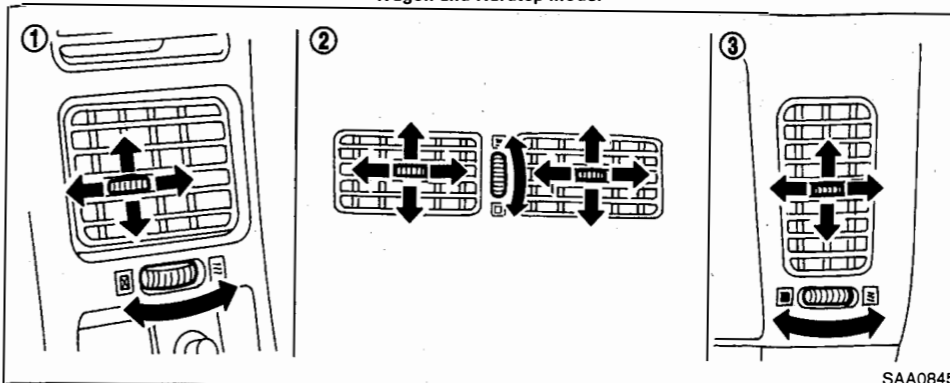

Pickup model

SAA0845

## FRONT VENTILATORS

- ① Driver side
- ② Center
- ③ Passenger side

Open or close, and adjust the air flow direction of ventilators.

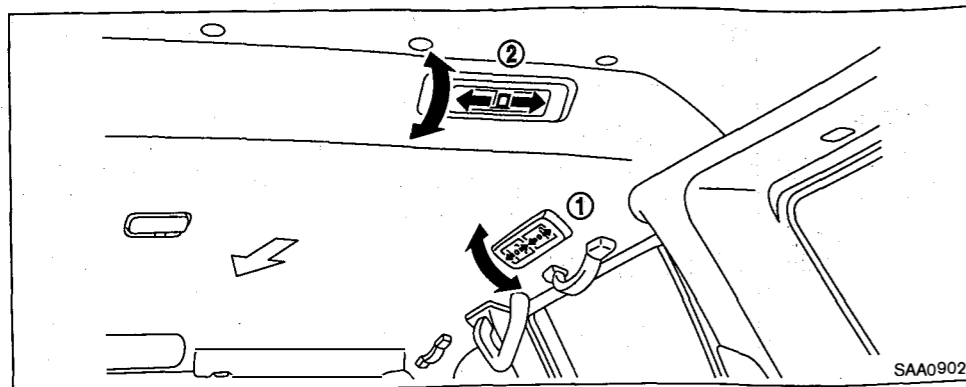

#### REAR VENTILATORS (if so equipped)

- ① Roof side
- ② Rear side

Open or close, and adjust the air flow direction of ventilators.

#### AIR CONDITIONER FILTER (ventilation air filter) (if so equipped)

The air conditioning system is equipped with an air conditioner filter (ventilation air filter) which collects dirt, pollen, dust, etc. To make sure air conditioner heats, defogs, and ventilates efficiently, replace the filter regularly. To replace the filter, contact a NISSAN dealer.

The filter should be replaced if air flow is extremely decreased or when windows fog up easily during operating heater or air conditioning system.

SAA0902

### HEATER AND AIR CONDITIONER (if so equipped)



#### WARNING:

- The heater and air conditioner operate only when the engine is running.
- Do not leave children or adults who would normally require the support of others alone in your vehicle. Pets should not be left alone either. On hot, sunny days, temperatures in a closed vehicle could quickly become high enough to cause severe or possibly fatal injuries to people or animals.
- Do not use the recirculation mode for long periods as it may cause the interior air to become stale and the windows to fog up.
- Positioning of the heating or air conditioning controls should not be done while driving, so full attention may be given to vehicle operation.

#### OPERATING TIPS

##### Heater

- Clear snow and ice from the wiper blade and air inlet in front of the windshield. This will improve heater operation.
- A slight delay may be experienced when turning the air control dial. This is not a

malfunction, it is only the system motors and solenoids switching from one outlet to another.

##### Air conditioner

- Keep windows and sun roof closed while the air conditioner is in operation.
- After parking in the sun, drive for two or three minutes with the windows open to vent hot air from the passenger compartment. Then, close the windows. This will allow the air conditioner to cool the interior more quickly.
- The air conditioning system should be operated for about ten minutes at least once a month. This helps prevent damage to the system due to lack of lubrication.
- If the coolant temperature gauge exceeds the hot position, turn the air conditioner off. For additional information, see "If your vehicle overheats" in the "6. In case of emergency" section.

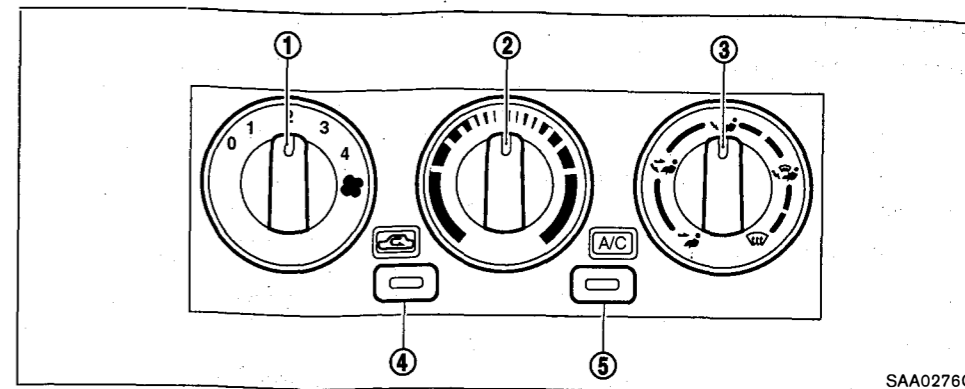

#### MANUAL AIR CONDITIONER

##### Controls

##### ① Fan speed control dial:

This dial turns the fan on and off, and controls fan speed.

##### ② Temperature control dial:

This dial allows you to adjust the temperature of the outlet air.

##### ③ Air flow control dial:

This dial allows you to select the air flow outlets.

— Air flows from center and side ventilators.

— Air flows from center and side ventilators and foot outlets.

— Air flows mainly from foot outlets.

— Air flows from defroster outlets and foot outlets.

— Air flows from defroster outlets.

##### ④ Air recirculation button:

OFF position:

Outside air is drawn into the passenger compartment.

Use the OFF position for normal heater, or air conditioner operation.

If dust is not raised in front of the vehicle, this

SAA0276C

position is effective to prevent dust entry.

ON position (Indicator light on):

Interior air is recirculated inside the vehicle.

Push the air recirculation button to the ON position when driving on a dust raised road or to avoid traffic fumes.

#### ⑤ Air conditioner button (if so equipped):

This button is provided only for vehicles with air conditioner.

Start the engine, move the fan speed control dial to the desired (1 to 4) position and push the air conditioner button to turn on the air conditioner. The indicator light will come on when the air conditioner button is on. To stop the air conditioner, push the air conditioner button again to return it to the original position.

**The air conditioner cooling function operates only when the engine is running.**

Heater operation

#### Heating:

This mode is used to direct hot air from the floor outlets.

1. Push the air recirculation button to the OFF position for normal heating.

2. Turn the air control dial to the  position.

3. Turn on the fan speed control dial.

4. Turn the temperature control dial to the desired position between the middle and the hot position.

- For quick heating, move the air recirculation button to the ON position. Be sure to return the air recirculation button to the OFF position for normal heating.

#### Ventilation:

This mode directs outside air from the side and center vents.

1. Push the air recirculation button to the OFF position.
2. Turn the air control dial to the  position.
3. Turn on the fan speed control dial.
4. Turn the temperature control dial to the desired position.

#### Defrosting/defogging:

This mode is used to defrost/defog the windows.

1. Push the air recirculation button to the off position.
2. Turn the air control dial to the  position.
3. Turn on the fan speed control dial.

4. Turn the temperature control dial to the desired position between the middle and the hot position.

- To quickly remove ice from the windows, push the air recirculation button to the on position, the fan speed control dial to 4 and the temperature control dial to the full hot position. As soon as possible after the window is clear, push the air recirculation button to the OFF position.

#### Bi-level heating:

This mode directs outside air from the side and center vents and hot air from the floor outlets.

1. Push the air recirculation button to the OFF position.
2. Turn the air control dial to the  position.
3. Turn on the fan speed control dial.
4. Normally turn the temperature control dial to the midpoint between hot and cold.

#### Heating and defogging:

This mode heats the interior and defogs the windshield.

1. Push the air recirculation button to the OFF position.
2. Turn the air control dial to the  position.

3. Turn on the fan speed control dial.

4. Turn the temperature control dial to the desired position between the middle and the hot position.

#### Air conditioner operation

Start the engine, move the fan control dial to the desired (1 to 4) position and push in the air conditioner button to activate the air conditioner. When the air conditioner is on, cooling and dehumidifying functions will be added to the heater operation.

**The air conditioner cooling function operates only when the engine is running.**

#### Cooling:

This mode is used to cool and dehumidify.

1. Push the air recirculation button to the off position.
2. Turn the air control dial to the  position.
3. Turn on the fan speed control dial.
4. Push on the air conditioner button. The indicator light will come on.
5. Turn the temperature control dial to the desired position.

- For quick cooling when the outside temperature is high, push the air recirculation button

to the on position. Be sure to return the air recirculation button to the OFF position for normal cooling.

A visible mist may be seen coming from the ventilators in hot, humid conditions as the air is cooled rapidly. This does not indicate a malfunction.

#### Dehumidified heating:

This mode is used to heat and dehumidify.

1. Push the air recirculation button to the OFF position.
2. Turn the air control dial to the  position.
3. Turn on the fan speed control dial.
4. Push on the air conditioner button. The indicator light will come on.
5. Turn the temperature control dial to the desired position.

#### Dehumidified defogging:

This mode is used to defog the windows and dehumidify.

1. Push the air recirculation button to the off position.
2. Turn the air control dial to the  position.
3. Turn on the fan speed control dial.

4. Push on the air conditioner button. The indicator light will come on.

5. Turn the temperature control dial to the desired position.

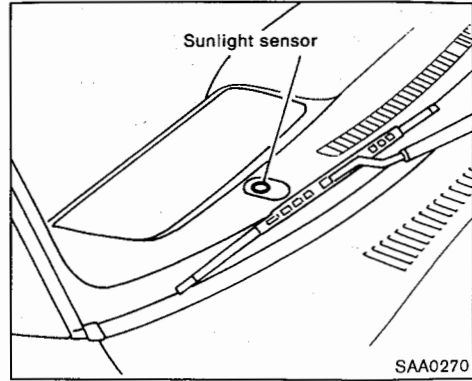

## AUTOMATIC AIR CONDITIONER

The sensor on the instrument panel helps maintain a constant temperature. Do not put anything on or around this sensor.

### Operating tips

When the engine coolant temperature and outside air temperature are low, the air flow from the foot outlets may not operate for a maximum of 150 seconds. However, this is not a malfunction. After the coolant temperature warms up, the air flow from the foot outlets will operate normally.

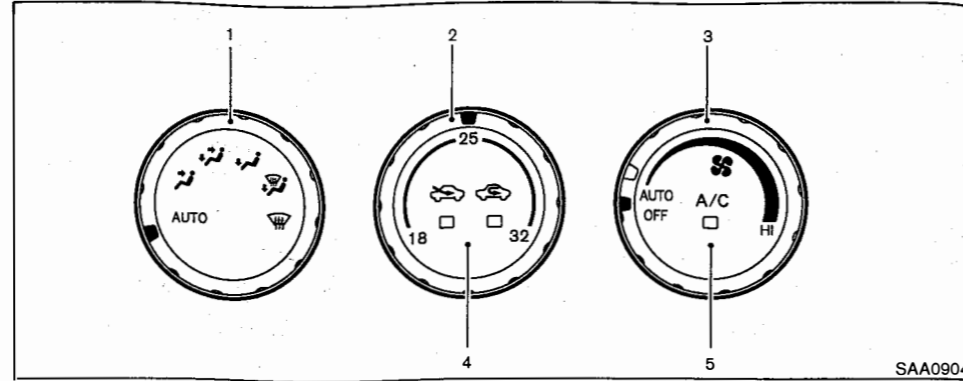

1. Air flow control dial
2. Temperature control dial
3. Fan speed control dial
4. Air intake button  
(Air recirculation and Outside air circulation)
5. A/C (Air conditioner) button

### Automatic operation

Start the engine and operate the controls to activate the air conditioner.

### Cooling and/or dehumidified heating (AUTO):

This mode may be normally used all year round as the system automatically works to keep a constant temperature. Air flow distribution and fan speed are also controlled automatically.

1. Turn the fan speed control dial and air flow control dial to the AUTO position.
2. Push the A/C button on. (The indicator light will come on.)

3. Turn the temperature control dial to set the desired temperature.
- Adjust the temperature control dial to about 25°C (77°F) for normal operation.
- The temperature of the passenger compartment will be maintained automatically. Air flow distribution and fan speed are also controlled automatically.

A visible mist may be seen coming from the ventilators in hot, humid conditions as the air is cooled rapidly. This does not indicate a malfunction.

### Heating (AUTO; A/C off):

The air conditioner cooling function does not activate. When you need to heat only, use this mode.

1. Turn the fan speed control dial and air flow control dial to the AUTO position.
2. Push the A/C button off to turn off the air conditioner. (The A/C button indicator light will go off.)
3. Turn the temperature control dial to set the desired temperature.
- The temperature of the passenger compartment will be maintained automatically. Air flow distribution and fan speed are also controlled automatically.

- Do not set the temperature lower than the outside air temperature. Otherwise the system may not work properly.
- Not recommended if windows fog up.

### Dehumidified defogging:

1. Turn the fan speed control dial to the desired position.
2. Turn the air flow control dial to the DEF position.
3. Turn the temperature control dial to set the desired temperature.

- To quickly remove ice from the outside of the windows, turn the fan speed control dial to the maximum position.

- As soon as possible after the windshield is clean, turn the air flow control dial to the AUTO position to return to the auto mode.

- When the air flow control dial is turned to the DEF position, the air conditioner will automatically be turned on at outside temperatures above -2°C (28°F) to defog the windshield, and the air recirculation mode will automatically be turned off.

Outside air is drawn into the passenger compartment to improve the defogging performance.

### Manual operation

#### Fan speed control:

Turn the fan control dial to manually control the fan speed.

Turn the dial to the AUTO position to return to automatic control of the fan speed.

#### Intake air control (Air recirculation/ Outside air circulation):

Each time the air intake button is pushed, the indicator light on the button will alternate as follows: (Air recirculation) → (Outside air circulation) → OFF

When the (Air recirculation) indicator light is on, the interior air is recirculated. Use this position when driving on a dust raised road or to avoid traffic fumes and for maximum cooling when using the air conditioner.





When the (Outside air circulation) indicator light is on, the outside air is drawn into the passenger compartment. Use this position for normal heater, or air conditioner operation. If dust is not raised in front of the vehicle, this position is effective to prevent dust entry.

When the indicator light on the button is OFF, the intake air will be controlled automatically.



### Air flow control:

Turning the air flow control dial selects the air outlet to:

-  : Air flows from center and side ventilators.
-  : Air flows from center and side ventilators and foot outlets.
-  : Air flows mainly from foot outlets.
-  : Air flows from defroster and foot outlets.
-  : Air flows mainly from defroster outlets.

To turn the system off

Turn the fan speed control dial to the OFF position.

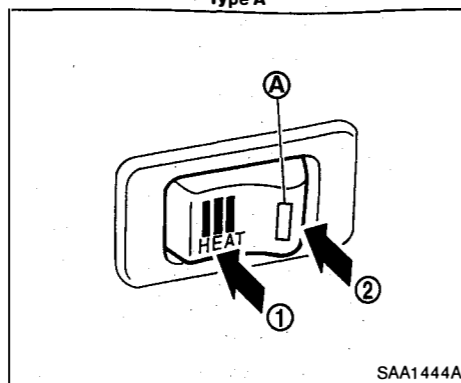
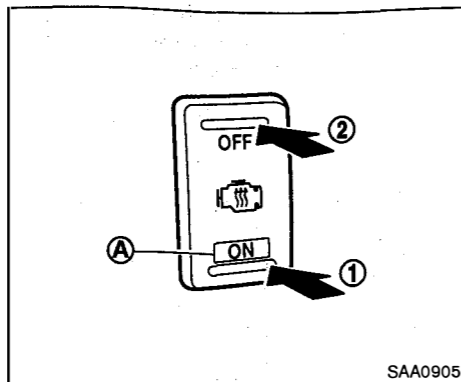

### HEAT SWITCH (for ZD30DDTi engine model)

The heat switch, located on the instrument panel, is used when the engine is cold to speed up the heater's operation. If the switch is turned to the ON position ① (the indicator light A will illuminate), the engine electronic control unit will automatically increase the cold engine idle speed.

The system works with the transmission in the P (Park) position (automatic transmission) or N (Neutral) position (manual transmission) and the throttle closed. Turn the heat switch OFF ② when the engine coolant temperature gauge moves. When the vehicle is being driven, the system is automatically deactivated.

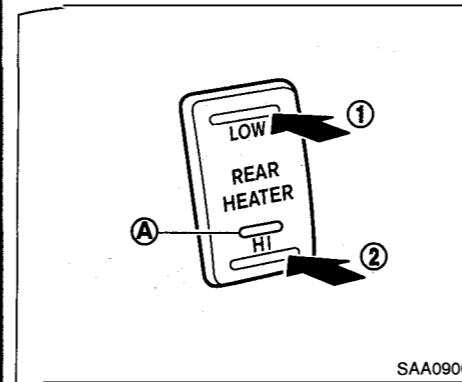

### REAR HEATER (if so equipped)

To activate the rear heater, take the following steps.

1. Start the engine.
2. Push the rear heater fan control switch. (The indicator light A will come on.)

- ① LOW — Air flows at low speed
- ② HI — Air flows at high speed

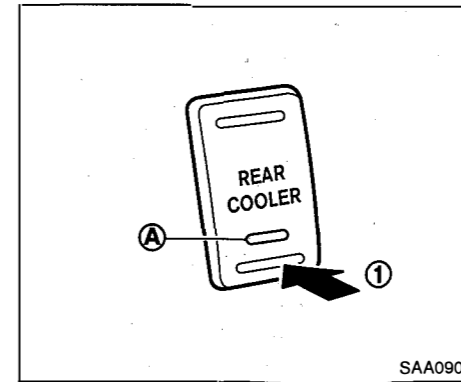

Front switch

### REAR COOLER (if so equipped)

To activate the rear cooler, take the following steps.

1. Start the engine.
2. Operate the front air conditioner.

**Rear cooler function operates only when the engine is running and the front air conditioner is operating.**

3. Push either the rear cooler fan front ① or rear switch ② on. (The indicator light A will come on.)

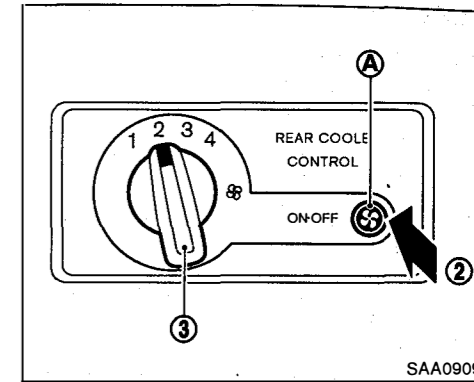

Rear switch

4. Turn the fan speed control switch ③ to desired position.

## COOL BOX (if so equipped)

### SERVICING AIR CONDITIONER

The air conditioning system in your NISSAN vehicle is charged with a refrigerant designed with the environment in mind.

**This refrigerant will not harm the earth's ozone layer.**

However it may contribute in a small part to global warming.

Special charging equipment and lubricant are required when servicing your NISSAN air conditioner. Using improper refrigerants or lubricants will cause severe damage to your air conditioning system. See "Air conditioning system refrigerant and lubricant recommendations" in the "9. Technical information" section of this manual.

A NISSAN dealer will be able to service your environmentally "friendly" air conditioning system.

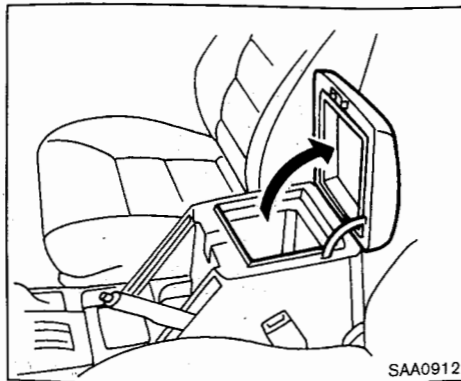

Put the drinks in the cool box and close the lid.

1. Start the engine.
2. Turn the front air conditioner on.

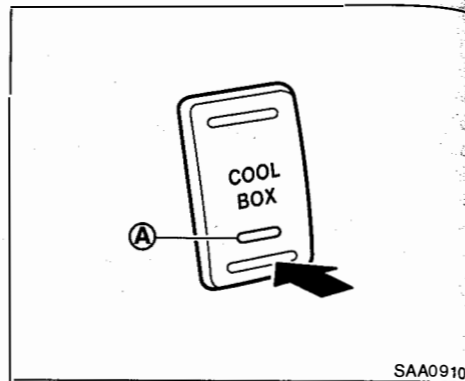

3. Push the cool box switch located on the instrument panel. (The indicator light **A** will come on.)

- Cool box will not be activated if the front air conditioner is turned off.
- The inner case can be removed for servicing or cleaning by removing the inner case securing screws.

## AUDIO SYSTEM (if so equipped)

### AUDIO OPERATION PRECAUTIONS

#### **WARNING:**

Do not adjust the audio system while driving so that full attention may be given to vehicle operation.

The audio system operates when the ignition switch is in the "ACC" or "ON" position.

#### Radio

- Radio reception is affected by station signal strength, distance from radio transmitter, buildings, bridges, mountains and other external influences. Intermittent changes in reception quality normally are caused by these external influences.
- Using a cellular phone in or near the vehicle may influence radio reception quality.

#### Cassette tape player

- To maintain good quality sound, NISSAN recommends that you use cassette tapes of 60 minutes or shorter in length.
- Cassette tapes should be removed from the player when not in use. Store cassettes in their protective cases and

away from direct sunlight, heat, moisture and magnetic sources.

Direct sunlight can cause the cassette to become deformed. The use of deformed cassettes may cause the cassette to jam in the player.

- Do not use cassettes that have labels which are peeling and loose. If used, the label could jam in the player.
- If a cassette has loose tape, insert a pencil through one of the cassette hubs and rewind the tape firmly around the hubs. Loose tape may cause tape jamming and wavering sound quality.
- Over a period of time, the playback head, capstan and pinch roller may gather a tape coating residue as the tape passes over the head. This residue accumulation can cause a weak or wavering sound and should be removed periodically with a head cleaning tape. If the residue is not removed periodically, the player may need to be disassembled for cleaning.

#### Compact Disc (CD) player

- During cold weather or rainy days, the player may malfunction due to the humidity. If this occurs, remove the CD and

dehumidify or ventilate the player completely.

- The player may skip while driving on rough roads.
- The CD player sometimes cannot function when the compartment temperature is extremely high. Decrease the temperature before use.
- Do not expose the CD to direct sunlight.
- CDs that are of poor quality, dirty, scratched, or covered with finger prints, or that have pin holes may not work properly.
- The following CDs may not work properly:
  - Copy control compact discs (CCCD)
  - Recordable compact discs (CD-R)
  - Rewritable compact discs (CD-RW)
- Do not use the following CDs as they may cause the CD player to malfunction.
  - 8 cm (3.1 in) discs with an adapter
  - CDs that are not round
  - CDs with a paper label

## ANTENNA

### Manual antenna

Adjust the antenna length for the best reception. A fully extended antenna is usually best for distant reception.

#### CAUTION:

Be sure to retract the antenna before washing the car in an automatic car wash, or the antenna may be damaged.

### Power antenna

The antenna will automatically extend when the radio is turned on, and retract when switched off. If the radio is left on, the antenna will retract with the ignition key OFF operation and extend with the ignition key ON or ACC operation.

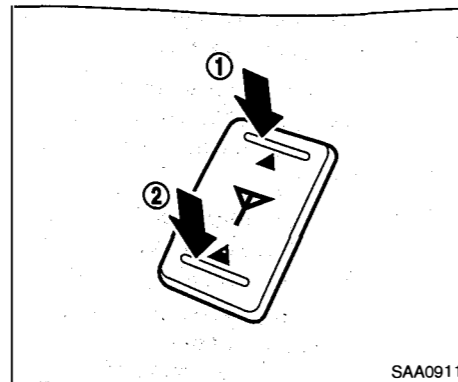

Type A

SAA0911

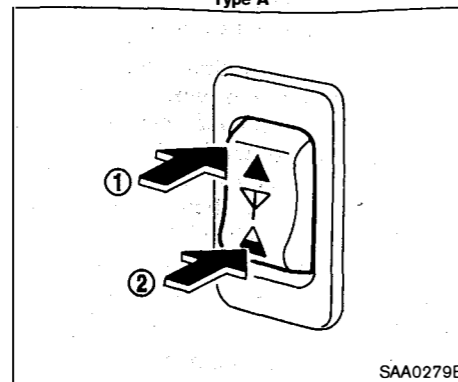

Type B

SAA0279B

### Power antenna switch (if so equipped):

If the power antenna extension control switch is equipped, the antenna will extend fully when the upper side of the switch is pushed ①, and the antenna will extend halfway when the lower side of the switch is pushed ②.

#### CAUTION:

- Before turning the radio on, make sure that there is no one near the antenna outlet and there is enough space for it to extend.
- To prevent damage, be sure that antenna is fully retracted before the vehicle enters an automatic car wash.
- Dirt and other foreign matter on the power antenna rod may interrupt its operation. Clean the rod periodically with a damp cloth. This type of cleaning is especially important during the winter seasons in areas where road salt and other chemicals may be spread on road surfaces and splashed onto the antenna rod.

### Window antenna

The antenna pattern is printed inside the rear side window.

#### CAUTION:

- Do not place metalized film near the rear side window. Do not attach any metal parts to the rear side window. This may cause poor reception and/or noise.
- When cleaning the inside of the rear side window, be careful not to scratch or damage the rear side window antenna. Lightly wipe along the antenna with a dampened soft cloth.

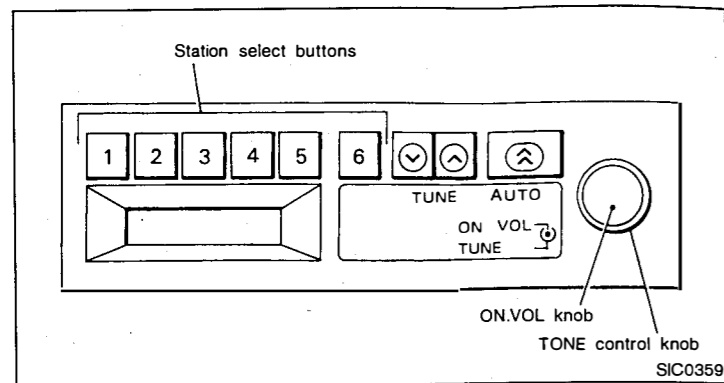

## AM RADIO

Turn the ON.VOL knob on to listen to the radio.

Turn the ON.VOL knob to adjust the volume.

### Frequency range and step change operations (for Central/South America)

The frequency range and step of this radio can be changed to the central/south American specification. To change the frequency range and step, proceed as follows:

1. Turn the audio unit on.
2. Press and hold the station select buttons 3 and 4.

3. Press the manual tuning button  $\wedge$  while the station select buttons 3 and 4 are being pressed. "AM 530 kHz" is displayed.

The frequency range and step have now been changed to the central/south American specification.

### Tuning



**The radio should not be tuned while driving so full attention may be given to vehicle operation.**

### Manual tuning:

Push down either manual tuning button  $\wedge$  or  $\vee$ .

### Auto tuning:

Push the auto tuning button  $\wedge$  to change broadcast to the next broadcasting station.

### Station memory operations

Six stations can be set.

1. Select the desired station.
2. Push a station select button for more than 1.5 seconds.
3. Other buttons can be set in the same manner.

If the battery cable is disconnected, or if the fuse blows, the radio memory will be cancelled. In that case, reset the desired stations.

### Adjusting tone quality

Rotate the TONE control knob to adjust the bass and treble.

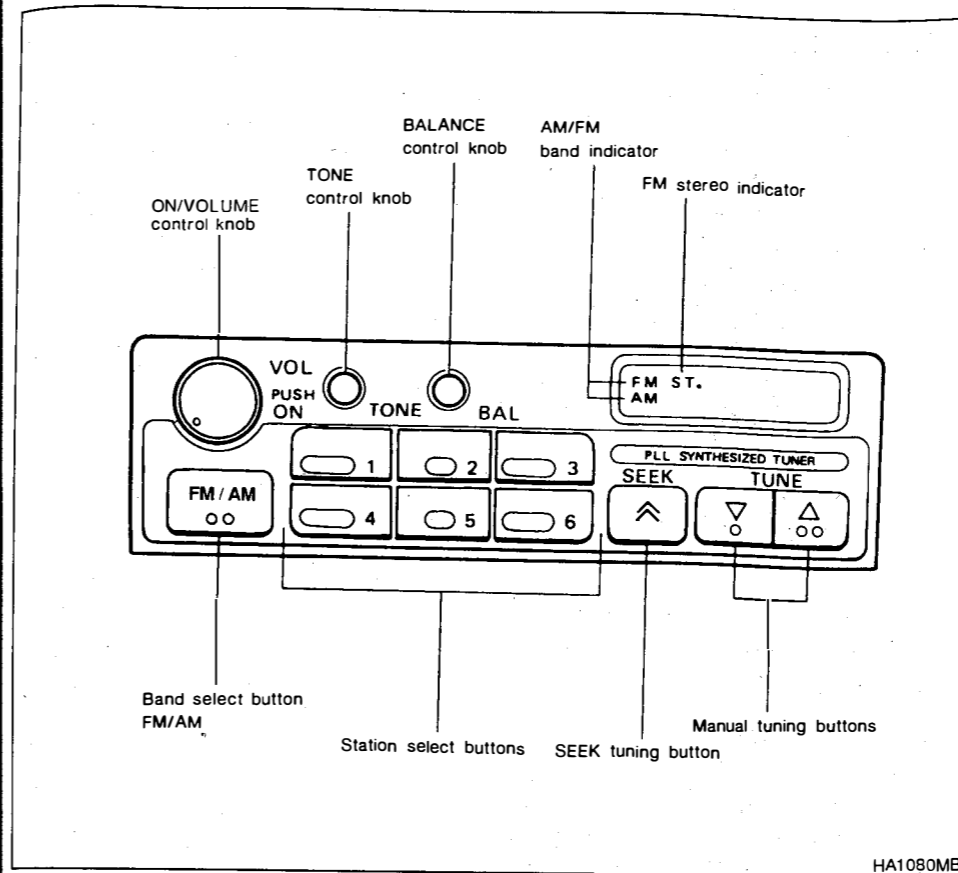

## FM-AM RADIO

Push the ON.VOL knob to listen to the radio and tune in the desired station.

Turn the ON.VOL knob to adjust the volume.

To turn off the radio, push the ON.VOL knob.

### Frequency range and step change operations (for Central/South America)

The frequency range and step of this radio can be changed to the central/south American specification. To change the frequency range and step, proceed as follows:

1. Turn the audio unit on.
2. Press and hold the station select buttons 3 and 4.
3. Press the manual tuning button  $\Delta$  while the station select buttons 3 and 4 are being pressed. AM 530 kHz is displayed.

The frequency range and step have now been changed to the central/south American specification.

### Selecting the desired band

Push the band select button "FM/AM" to change from AM to FM reception.

The stereo indicator will glow during FM stereo

reception. When the stereo broadcast signal is weak, the radio will automatically change from stereo to monaural reception.

### Tuning



#### WARNING:

The radio should not be tuned while driving so full attention may be given to vehicle operation.

#### Manual tuning:

Push down either manual tuning button "▼" or "▲".

#### AUTO tuning:

Push the SEEK tuning button "⋈" to change the broadcast to the next broadcasting station.

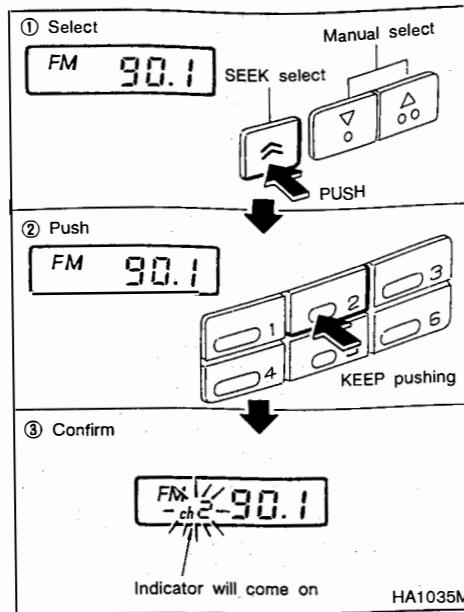

### Station memory operations

Six stations can be set for each band.

1. Tune to the desired station.
2. Depress the station select button for two seconds. The station's sound will be interrupted. When the sound returns, the desired station is stored in the memory and the

channel number is displayed.

3. Other buttons can be set in the same manner.

If the battery cable is disconnected, or if the fuse blows, the radio memory will be cancelled. In that case, reset the desired stations.

### Adjusting speaker sound balance

Turn the BALANCE (BAL) control knob to adjust the volume between the right and left speakers.

### Adjusting tone quality

Turn the control knob to obtain the most pleasant sound.

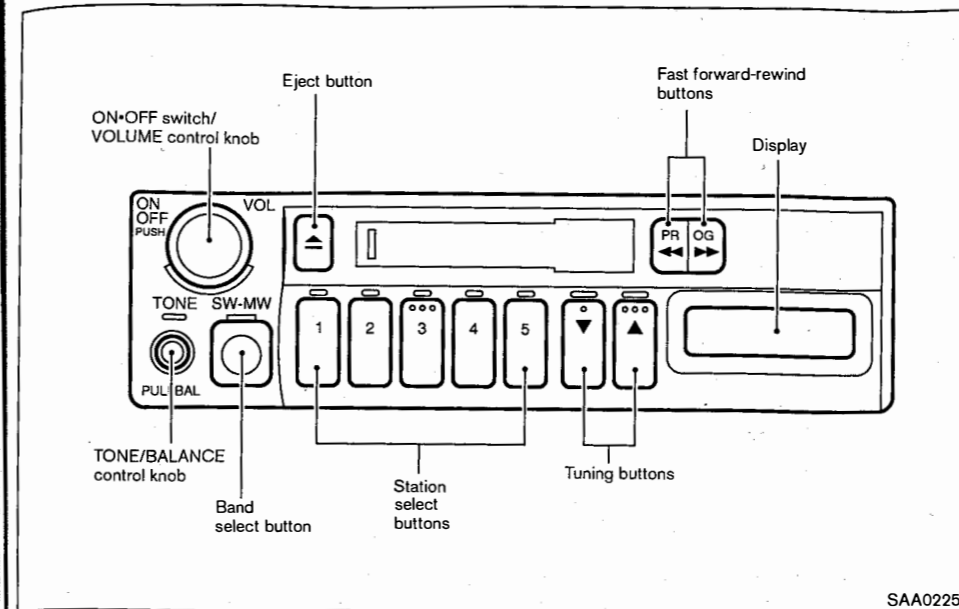

### MW-SW RADIO WITH CASSETTE TAPE PLAYER

Push the ON-OFF switch to listen to the radio and tune in the desired station.

Turn the VOLUME control knob to adjust the volume.

### Frequency range and step change operations (for Central/South America)

The frequency range and step of this radio can be changed to the central/south American specification. To change the frequency range and step, proceed as follows:

1. Turn the audio unit on.
2. Press and hold the station select buttons 3 and 4.
3. Press the manual tuning button ▲ while the station select buttons 3 and 4 are being pressed. MW 530 kHz is displayed.

The frequency range and step have now been changed to the central/south American specification.

### Selecting the desired band

Push the band select button to change from MW to SW reception.

### Tuning



#### WARNING:

The radio should not be tuned while driving so full attention may be given to vehicle operation.

#### Manual tuning:

Push down either tuning button "▼" or "▲".

#### AUTO tuning:

Push down either tuning button "▼" or "▲" for more than 1 second to change the broadcast to the next broadcasting station.

### Station memory operations

Five stations can be set for each band.

1. Select the desired station.
2. Push a station select button for more than 1.5 seconds.
3. Other buttons can be set in the same manner.

If the battery cable is disconnected, or if the fuse blows, the radio memory will be cancelled. In that case, reset the desired stations.

### Adjusting speaker sound balance

Pull and turn the BAL (BALANCE) control knob to adjust the volume between the right and left speakers.

### Adjusting tone quality

Turn the TONE knob to adjust the bass and treble.

### Cassette tape operation

Turn the ignition key to "ACC" or "ON", then lightly insert the cassette tape into the tape door.

The cassette tape will automatically pull into the player. The word "TAPE" and an arrow indicating tape side will illuminate in the display window.

**Do not force the tape into the cassette tape**

**door. Pressing strongly could cause player damage.**

The cassette tape will automatically change directions to play the other channel when the first channel is completed.

### Fast forwarding or rewinding the tape

Push either the "▶▶" forward or "◀◀" rewind button for the desired direction.

The "▶" or "◀" symbol will illuminate in the display. To stop, push the eject button.

### Changing the direction of tape play

Push the PROG (program) select button. The "▶" or "◀" symbol will illuminate in the display to indicate side of program play.

### Stopping and ejecting the cassette tape

Push the eject "⏏" button. The tape will stop playing and the cassette tape will automatically come out.

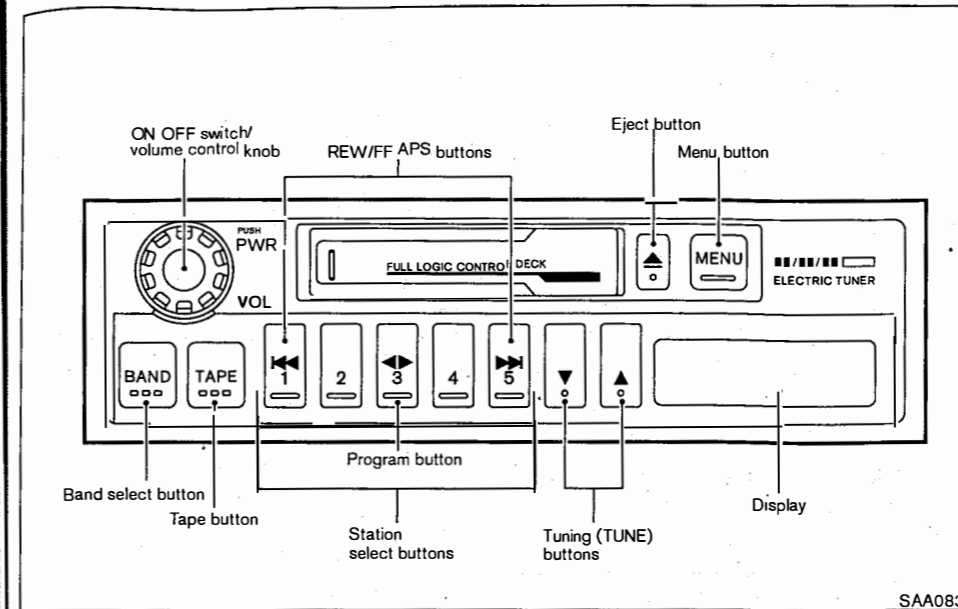

### FM-AM/MW-SW-FM RADIO WITH CASSETTE TAPE PLAYER

#### Audio main operation

##### ON-OFF/Volume control:

Push the ON-OFF switch to listen to the radio and tune in the desired station.

Turn the VOLUME control knob to adjust the volume.

##### MENU button:

Press the MENU button to change the selecting mode as follows.

BASS → TREBLE → FADE → BALANCE →  
Clock ON/OFF (→ clock adjustment-hour →

clock adjustment-minute)

To adjust BASS, Treble, Fader and Balance, press the MENU button until the desired mode BAS, TRE, FAD or BAL appears in the display. Press the TUNE (▼) or (▲) button to adjust Bass and Treble to the desired level. Use the ▼ or ▲ button also to adjust Fader or Balance modes. Fader adjusts the sound level between the front and rear speakers and Balance adjusts the sound between the right and left speakers.

For clock adjustment, see "Clock" in the "Instruments and controls" section.

After 10 seconds, the radio or cassette tape display reappears. Once the sound quality is set to the desired level, press the MENU button repeatedly until the radio or cassette tape display appears.

### Frequency range and step change operations (for Central/South America)

The frequency range and step of this radio can be changed to the central/south American specification. To change the frequency range and step, proceed as follows:

1. Turn the radio unit off by pushing the ON-OFF switch.

- Turn the radio unit on by pushing the ON-OFF switch while pushing station select buttons 1 and 5.

If you experience difficulties in changing the radio specification, contact a NISSAN dealer.

### Radio operation

#### **BAND** Radio band select:

Push the BAND select button to change the reception (FM-AM or MW-SW-FM).



#### **TUNE (Tuning):**



#### **WARNING:**

The radio should not be tuned while driving so full attention may be given to vehicle operation.

#### Manual tuning:

Push down either tuning button "▼" or "▲".

#### AUTO tuning:

Push down either tuning button "▼" or "▲" for more than 0.5 second to change the broadcast to the next broadcasting station.

#### Station memory operations:

Five stations can be set for each band.

- Select the desired station.

- Push a station select button for more than 1.5 seconds.

- Other buttons can be set in the same manner.

If the battery cable is disconnected, or if the audio fuse blows, the radio memory will be erased. In such a case, reset the desired stations.

### Cassette tape player operation

Turn the ignition key to "ACC" or "ON", then lightly insert the cassette tape into the tape door.

The cassette tape will automatically pull into the player. The word "TAPE" and an arrow indicating tape side will illuminate in the display window.

**Do not force the tape into the cassette tape door. Pressing strongly could cause player damage.**

The cassette tape will automatically change its directions when one side of the tape has finish running.

#### **TAPE PLAY:**

- When the TAPE button is pushed with the system turned off and a tape loaded, the system will come on and the tape will play.
- When the TAPE button is pushed with either the radio or compact disc turned on and the tape loaded, the compact disc or the radio

will automatically be turned off and the tape will play.

#### Changing the direction of tape play:

Push the ◀▶ (program) button. The "1" or "2" symbol will illuminate in the display to indicate side of program play.



#### **APS (automatic program search) FF, APS REW:**

Push either the APS ◀▶ or APS ▶▶ button while the cassette tape is playing. The tape runs quickly, stops, then plays the next selection.

This system searches at the blank intervals between selections. If there is a blank interval within one selection or there is no interval between selections, the system may not stop in the desired or expected location.



#### **TAPE EJECT:**

Push the eject "⏏" button. The tape will stop playing and the cassette tape will automatically come out.

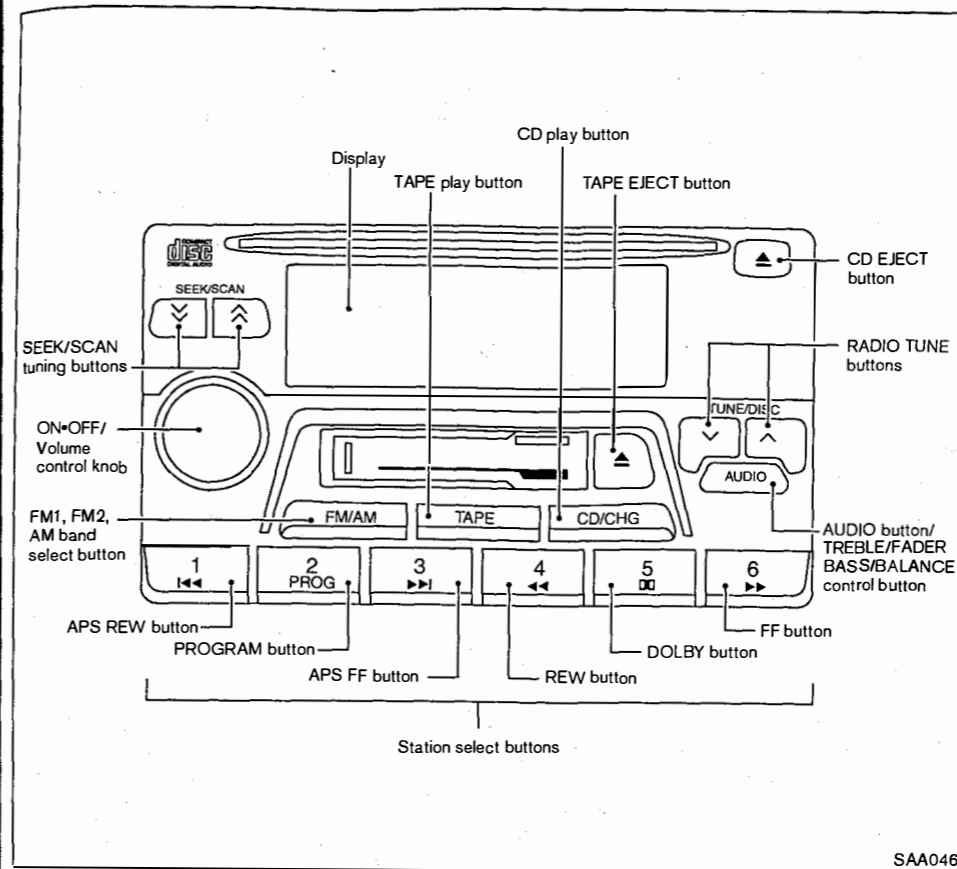

## FM-AM RADIO WITH CASSETTE TAPE PLAYER AND COMPACT DISC (CD) PLAYER

### Audio main operation

#### Head unit:

The radio has an FM diversity reception system, which employs two antennas. One is a rod type antenna; the other is an antenna printed on the window. This system automatically switches to the antenna which is receiving less noise.

The tape deck employs a permalloy head which allows for improved reproduction of high frequency ranges. Noise is also greatly reduced by the combined use of the Dolby NR (Noise Reduction) system. The auto loudness circuit enhances the low frequency range automatically in both radio reception and tape and CD playback.

#### ON-OFF/Volume control:

Turn the ignition key to ACC or ON, and then push the ON-OFF/VOL control knob while the system is off to call up the mode (radio, tape or CD) which was playing immediately before the system was turned off. When no CD or tape is loaded, the radio will come on. While the system is on, pushing the ON-OFF/VOL control knob turns the system off.

To turn the radio off, press the ON-OFF/VOL control knob.

Turn the ON-OFF/VOL control knob to adjust the volume.

**Frequency range and step change operations (for Central/South America):**

The frequency range and step of this radio can be changed to the central/south American specification. To change the frequency range and step, proceed as follows:

1. Turn the audio unit on.
2. Press and hold the station select buttons 3 and 4.
3. Press the manual tuning button  $\wedge$  while the station select buttons 3 and 4 are being pressed. "AM 530 kHz" is displayed.

The frequency range and step have now been changed to the central/south American specification.

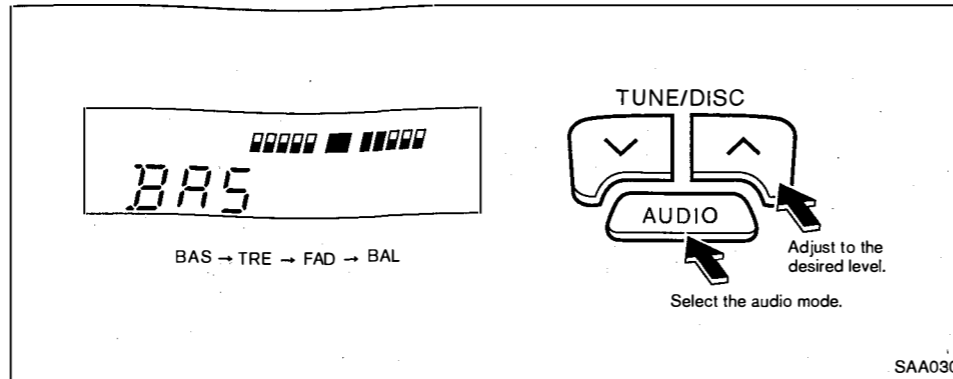

**Adjusting tone quality and speaker balance:**

To adjust BASS, TRE (Treble), BAL (Balance) and FAD (Fader), press the AUDIO button until the desired mode BAS, TRE, FAD or BAL appears in the display. Press the  $\vee$  or  $\wedge$  button to adjust Bass (BAS) and Treble (TRE) to the desired level. Use the  $\vee$  or  $\wedge$  button also to adjust Fader (FAD) or Balance (BAL) modes. FAD adjusts the sound level between the front and rear speakers and BAL adjusts the sound between the right and left speakers. After 10 seconds, the radio, cassette tape or CD display reappears. Once the sound quality is set to the desired level, press the AUDIO button repeatedly until the radio, cas-

sette tape or CD display appears.

**FM-AM radio operation**

**FM/AM FM/AM band select:**

Pushing the FM/AM band select button will change the band FM1, FM2 or AM.

When FM/AM band select button is pushed while the ignition switch is in the ACC or ON, the radio will come on at the station last played.

The last station played will also come on when the power knob is turned to ON.

If a compact disc or tape is playing when the FM/AM band select button is turned to ON, the compact disc or tape will automatically be

turned off and the last radio station played will come on.

The FM stereo indicator ST will glow during FM stereo reception. When the stereo broadcast signal is weak, the radio will automatically change from stereo to monaural reception.



**WARNING:**

**The radio should not be tuned while driving so full attention may be given to vehicle operation.**

Use these buttons for manual tuning. To move quickly through the channels, hold either of the TUNE buttons down for more than 0.5 second.



**SEEK tuning**

Push the SEEK/SCAN tuning button  $\approx$  or  $\approx$  for less than 1.5 seconds. SEEK tuning begins from high to low or low to high frequencies and stops at the next broadcasting station.

**SCAN tuning**

Push the SEEK/SCAN tuning button  $\approx$  or  $\approx$  for more than 1.5 seconds. SCAN tuning begins from high to low or low to high frequencies and stops at each broadcasting station for

10 seconds. Pushing the button again during this 10 seconds period will stop SCAN tuning and the radio will remain tuned to that station.

If the SEEK/SCAN tuning button is not pushed within 10 seconds, SCAN tuning moves to the next station.

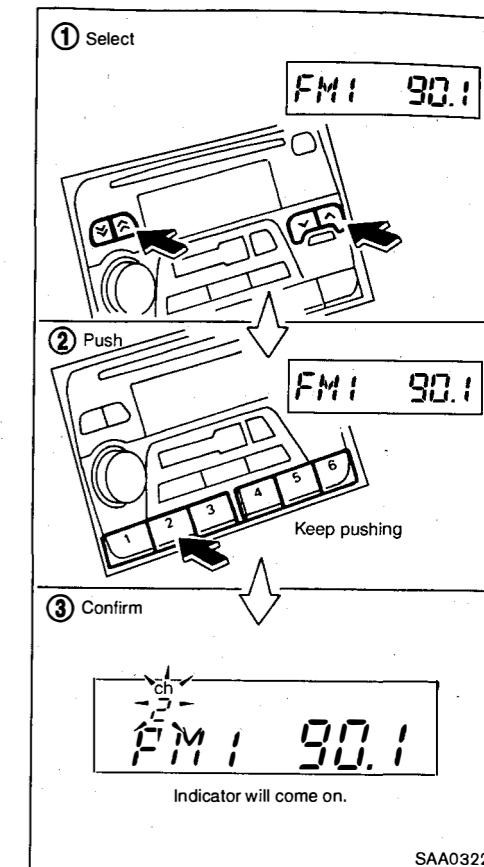



### Station memory operations:

Twelve stations can be set for the FM band (six for FM1, six for FM2).

Six stations can be set for the AM band.

1. Tune to the desired station using the SEEK/SCAN or TUNE button.
2. Push the desired station select button for more than 1.5 seconds. (For example, in the diagram ch2 is to be memorized. The radio mutes when the select button is pushed.)
3. The indicator ch2 will then come on and the sound will resume. Memorizing is now complete.
4. Other buttons can be set in the same manner.

If the battery cable is disconnected, or if the fuse blows, the radio memory will be cancelled. In that case, reset the desired stations.

### Cassette tape player operation

Turn the ignition key to ACC or ON, and then lightly insert the cassette tape into the tape door. The cassette tape will be automatically pulled into the player.

The radio or CD will turn off (if it is on) and the cassette tape will begin to play.

### CAUTION:

**Do not force the cassette tape into the tape door. This could cause player damage.**

If the system is turned off by pushing the ON-OFF/VOL control knob with the cassette tape still in the player, the tape will resume playing when the system is turned back on.

### TAPE PLAY:

- When the TAPE button is pushed with the system turned off and a tape loaded, the system will come on and the tape will play.
- When the TAPE button is pushed with either the radio or compact disc turned on and the tape loaded, the compact disc or the radio will automatically be turned off and the tape will play.
- If the TAPE button is pushed during either the FF, REW, APS FF or APS REW function, the cassette tape enters the normal play mode.



Push the ►► (fast forward) button to fast forward the tape. To rewind the tape, push the ◀◀ (rewind) button. Either the FF or REW symbol illuminates on the right side of the display window. To stop the FF or REW function, press

the ►► (fast forward) or ◀◀ (rewind) again, or the TAPE button.

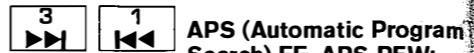

**APS (Automatic Program Search) FF, APS REW:**

When the ►► (APS FF) button is pushed while the tape is being played, the next program will start to play from the beginning. Push the ►► (APS FF) button several times to skip through programs. The tape will advance the number of times the button is pushed (up to nine programs).

When the ◀◀ (APS REW) button is pushed once, the program being played starts over from the beginning. Push the ◀◀ (APS REW) button several times to skip back several selections. The tape will go back the number of times the button is pushed. Either the FF or REW symbol flashes on the right side of the display window while searching for the selection.

To stop the APS FF or APS REW function, push the TAPE button.

This system searches for the blank intervals between selections. If there is a blank interval within one program or there is no interval between programs, the system may not stop in the desired or expected location.

### **PROG (Program):**

Push the PROG button to change the tape side while the tape is being played.

The cassette tape will automatically change directions to play the other side when the first side is completed.

If the PROG button is pushed during the FF or REW function, the cassette tape enters the normal play mode.

### **Dolby NR (Noise Reduction):**

Push the Dolby NR  button for Dolby NR encoded tapes to reduce high frequency tape noise. The indicator will come on.

Dolby noise reduction is manufactured under license from Dolby Laboratories Licensing Corporation. Dolby NR and the double-D symbol  are trademarks of Dolby Laboratories Licensing Corporation.

### **Metal or chrome tape usage:**

The cassette player will be automatically set to high performance play when playing a metal or chrome cassette tape.

### **TAPE EJECT:**

When this button is pushed with the tape loaded, the tape will be ejected.

When the tape is ejected while it is being played, the system will be turned off.

### Compact disc (CD) player operation

Turn the ignition switch to the ACC or ON position and insert the CD into the slot with the label side facing up. The CD will be guided automatically into the slot and start playing.

After loading the disc, the number of tracks on the disc and the play time will appear on the display.

If the radio or tape is already operating, it will automatically turn off and the CD will play.

### CAUTION:

**Do not force the compact disc into the slot. This could damage the player.**

If the system has been turned off while the CD was playing, pushing the ON-OFF/VOL control knob will start the CD.

8 cm diameter CD can also be used without an adapter.

### **PLAY:**

- When the CD/CHG button is pushed with the CD loaded and the system off, the system will turn on and the CD player will turn on.
- When the CD/CHG button is pushed with no disc in the player, the NO DISC indicator will flash on the display.
- When the CD/CHG button is pushed with

the CD loaded in the player but the tape or the radio playing, the tape or radio will automatically be turned off and the CD player will turn on.



**FF (Fast Forward), REW (Rewind):**

When the ►► (fast forward) or ◀◀ (rewind) button is pushed while the CD is being played, the CD will play while fast forwarding or rewinding. When the button is released, the CD will return to normal play speed.

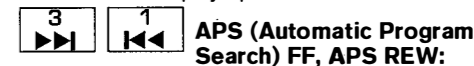

**APS (Automatic Program Search) FF, APS REW:**

When the ►► (APS FF) button is pushed while the CD is being played, the program next to the present one will start to play from its beginning. Push several times to skip through programs. The CD will advance the number of times the button is pushed. (When the last program on the CD is skipped through, the first program will be played.) When the ◀◀ (APS REW) button is pushed, the program being played returns to its beginning. Push several times to skip back through programs. The CD disc will go back the number of times the button is pushed.

**2**  
**PROG (Program):**

When the PROG button is pushed while the CD is being played, the play pattern will change as follows:

no mark: All the programs will be played repeatedly in sequence.

1: Only one program (the one being played when the PROG button is pushed) will be repeated.

RANDOM: Programs will be played at random, not following the sequence on the CD. The same program may be repeated twice.

**When the CD is ejected, the play pattern will automatically change to no mark.**

**CD EJECT:**

When the CD EJECT button is pushed with the CD loaded, the CD will be ejected.

When this button is pushed while the CD is being played, the CD will come out and the system will turn off.

**If the CD comes out and is not removed, it will be pulled back into the slot to protect it. (This function will not work for 8 cm diameter compact discs.)**

**CD IN indicator:**

CD IN indicator appears on the display when the

CD is loaded with the system on.

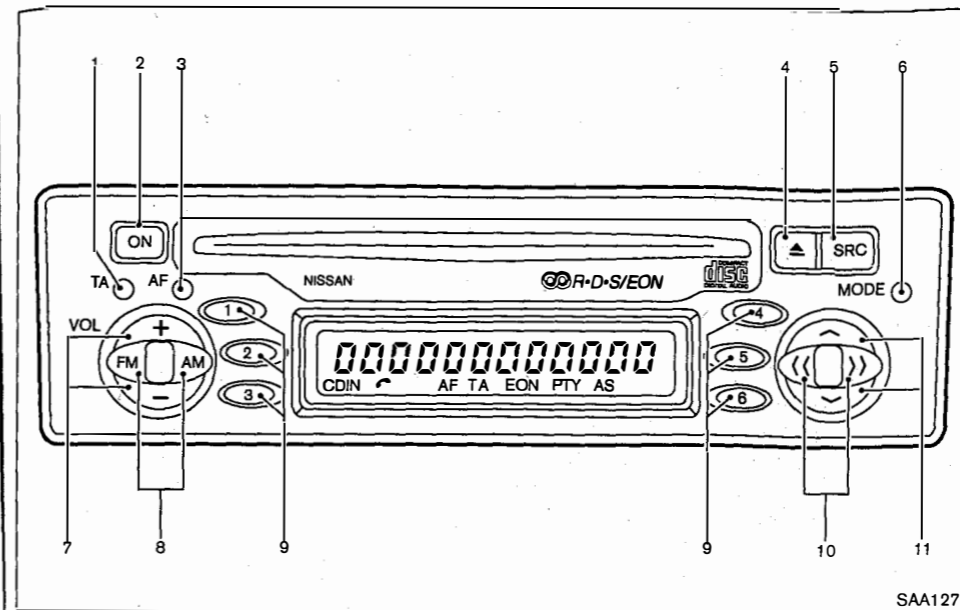

1. TA (Traffic Announcement) button
2. POWER button
3. AF (Alternative Frequency) button
4. CD EJECT button
5. SRC (Source selector) button
6. MODE button

7. VOLUME control button
8. Radio band select button
9. Radio memory buttons
10. SEEK/TRACK button
11. TUNE button

**LW-MW-FW RADIO WITH  
COMPACT DISC (CD) PLAYER**

This unit is an electronic LW-MW-FM radio and CD player with an anti-theft system and traffic announcement function.

**Ant-theft system (without personal code)**

This unit can only be activated when the ignition key for NATS is in the ACC or ON position.

Each radio is uniquely matched to the vehicle's immobilizer and therefore cannot be transferred to any other vehicle.

**Anti-theft system (with personal code)**

By using a personal 4-digit code known only to the vehicle owner, the possibility of the audio unit being stolen is effectively reduced, because without the code, the unit cannot be activated. When used normally, the unit is unlocked and accessible in the usual way.

If however, force is used to try and remove the unit, the anti-theft system activates and the unit locks. The only way it can be unlocked is by entering the personal code number known only by the owner. This code number cannot be altered and applies only to your vehicle. This code number is shown on a radio pass card. The radio pass card is installed in the glove box at the

vehicle productions site. Ask a NISSAN dealer for the location of your radio pass card.



**WARNING:**

Keep the radio pass card in a safe place and refrain from keeping it in the vehicle. Contact a NISSAN dealer if you lose the radio pass card or forget the code number of your radio.

**Unlocking the unit:**

Read this section very carefully. It is important that the instructions are followed precisely.

If the battery supply to the vehicle is interrupted by accident for some reason, the unit will lock.

To unlock the unit, proceed as follows:

1. Press the power/volume control knob to turn the unit on.
2. CODE IN is displayed.
3. Input your personal code by pressing the preset buttons (1 to 4).
4. Press the  $\wedge$  button.
5. If the entered code number is correct, the radio turns on. A radio frequency appears on the display.
6. If the entered code is incorrect, the unit

becomes inoperable for 10 seconds for the first three attempts, then the code input mode is automatically set (CODE IN is displayed).

7. If the code is incorrect the fourth time, the unit becomes inoperable for 60 minutes and (----) is displayed. After 60 minutes, the code input mode is automatically set (CODE IN is displayed). If the above is repeated 17 times, the unit will lock permanently and you will need to contact a NISSAN dealer.

**Audio main operation**

**Power switch:**

Turn the ignition switch to the ACC or ON position, then push the power switch. The mode (radio or CD) which was playing immediately before the system was turned off resumes playing. If there is no CD inserted in the player, the radio comes on. Pushing the power switch again turns the system off.

**Volume control:**

Press the + or - side of the volume control button to adjust the volume.

**CAUTION:**

Turning the ignition switch on or turning the power on with the volume set at the maximum position can damage your ears.

**SRC Source selector:**

This button selects the listening source between radio and CD. Each time the button is pressed, the respective mode will be displayed.

If no CD is inserted, the unit will switch automatically to the next source after 3 seconds. During these 3 seconds the display shows NO DISC.

**MODE Audio selection mode:**

Press the audio selection mode (MODE) button to select bass, treble, balance, fader and loudness with the  $\wedge$  or  $\vee$  buttons.

The mix mode is added to this menu as well.

The audio selection mode will switch off automatically after 8 seconds if no button is pressed.

**Radio Mode**

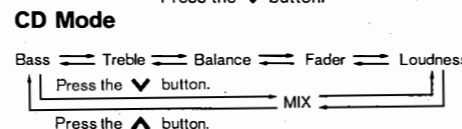
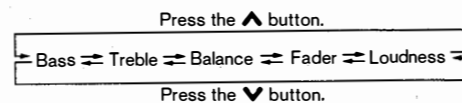

**BASS control**

Use this mode to enhance or attenuate bass response.

Press the  $\ll$  or  $\gg$  button while in the bass control mode to adjust the bass.

**TREBLE control**

Use this mode to enhance or attenuate the treble.

Press the  $\ll$  or  $\gg$  button while in the treble control mode to adjust the treble.

**BALANCE control**

Use this mode to adjust the balance of the volume between the left and right channels. Press the  $\ll$  or  $\gg$  button while in the balance control mode to adjust the left/right balance.

**FADER control**

Use this mode to adjust the balance of the volume between the front and rear channels.

Press the  $\ll$  or  $\gg$  button while in the fader control mode to adjust the front/rear balance.

**MIX control**

During the CD mix mode, each press of the  $\ll$  or  $\gg$  button will cause the audio unit to scroll through three menu options as follows:

MIX/REPEAT OFF - REPEAT TRACK - MIX DISC.

Audio mode indications and description of operation.

AUDIO MODE	AUDIO CONTROL UP/DOWN BUTTON		
	$\ll$	Center position	$\gg$
BASS (bass adjustment)	BASS -5	BASS 0	BASS +5
TREBLE (treble adjustment)	TREB -5	TREB 0	TREB +5
BALANCE (left/right balance adjustment)	BAL L 7 (BALANCE Left)	BAL 0	BAL R 7 (BALANCE Right)
FADER (front/rear balance adjustment)	FAD R 7 (FADER Rear)	FAD 0	FAD F 7 (FADER Front)

**LOUDNESS ON/OFF**

Press the  $\ll$  or  $\gg$  button while in the audio mode to turn the loudness function on and off. The loudness mode is displayed as follows:

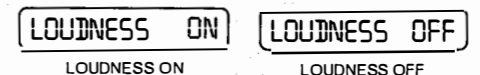

**Radio operation**

**FM** **AM** Band select/Auto store:

When you press the FM/AM button, the reception band-changes in the following order:

**FM Band**

FM  $\rightarrow$  FM  
FM  $\leftarrow$  (AS)

**AM Band**

MW  $\rightarrow$  LW  
MW  $\leftarrow$  LW

During FM reception, when the FM button is pressed for at least two seconds, stations are searched for automatically and the six stations with the strongest signals are automatically stored into the preset buttons (1 to 6) in FM (AS).

The sound is muted until the auto store operation is completed.



**WARNING:**

The radio should not be tuned while driving in order for full attention to be given to the driving operation.

Press these buttons to tune the stations manually. The frequency increases when the

^ button is pressed and decreases when the v button is pressed.

The frequency changes in steps of 100 kHz on the FM band, 9 kHz on the MW band, and 3 kHz on the LW band.

If either the ^ or v button is held down for longer than 0.5 second, the frequency will continuously increase or decrease on the band until the button is released.

#### SEEK tuning:

Pushing the SEEK button << or >> tunes from high to low or low to high frequencies and stops at the next broadcasting station.

#### 1 to 6 Preset:

Press a preset button for less than 2 seconds to receive the station preset at that button.

Pressing a preset button for more than 2 seconds will cause the station currently being received to be stored in the memory of that button.

Twelve stations can be set for the FM band (six to FM, six for FM-AS).

Six stations can be set for both the MW and LW bands.

## Radio data system (RDS)

### Alternative Frequency (AF):

- The AF function operates in the FM (radio) and CD Mode.
- When the AF button is pressed for less than 2 seconds, the AF function is turned on.
- When the AF button is pressed for more than 2 seconds in FM mode, the REG (Regional) function operates.

The following functions operate when the AF mode is on:

### Automatic switching function

This function compares the strengths of the signals of the stations on the AF (alternative frequency list) and selects the station with the optimum reception conditions.

### Program information (PI) search

Program information (PI) search begins automatically if no suitable station is found with the above automatic switching function. The PI search function checks each RDS station with the same PI code. During this time the sound is muted and PI SEARCH is displayed. The PI search operation stops when a suitable station is found. If no station is found once all the frequencies have been searched, the radio returns to the previous frequency.

### Enhanced Other Network (EON) data update (this function also operates when the AF mode is off.)

When EON data is being received, this enables automatic retuning of other pressure stations on the same network. Also network linked services can be used. EON indicator lights up during receiving RDS EON stations while in the FM band.

### RDS functions:

#### Program Service (PS) function (station name display function)

When an RDS station is tuned in with seek or manual tuning, the program station name will be displayed immediately after receiving the RDS data.

#### Emergency broadcast interrupt function [ALARM INTERRUPTION — EBU (European Broadcasting Union) SPEC FOR INFO]

When the radio receives PTY code 31 (an emergency broadcast code), the sound is interrupted, the emergency broadcast is heard, and PTY31 ALARM is displayed. The volume level at this time is the same as that for traffic announcements. Once the emergency broadcast is finished, the unit immediately returns to the previous source.

### REG (Regional) mode

This mode is turned on and off by pressing the AF button for more than 2 seconds while in the FM mode. When the mode is turned on, REG ON is displayed for 3 seconds and all bits of the PI code are checked during the automatic switching function. When the REG mode is turned off, all bits of the PI code (except the area code) are checked during the automatic switching function.

### Traffic announcement (TA):

This function operates in the FM (radio) and CD mode.

- The TA mode is selected when the TA button is pressed for less than 2 seconds. TA indicator lights in the TA ON mode.
- The TA mode operates whether the AF mode is on or off.
- TA icon (TA) is displayed when the TA mode is turned on. TA OFF is displayed when the TA mode button is pressed for less than 2 seconds.

### Traffic announcement interrupt function

When a traffic announcement is received while the TA mode is set, the announcement is tuned in and the volume increases to the set level. TRAFFIC INFO is displayed. Once the traffic

announcement is finished, the unit returns to the source which was set before the traffic announcement started and the volume returns to the previous level. For EON stations, the radio is interrupted by EON stations with traffic announcements. The TA mode is cancelled if the TA button is pressed during a traffic announcement.

### Traffic announcement seek

If no station providing traffic announcements (in TA mode) is found once all the frequencies have been searched, the radio returns to the previously tuned in station and NO TRAFFIC is displayed for 3 seconds.

### Volume level for traffic announcements

The volume for traffic announcements can be set by using the function adjustment button << or >> as described in the user set up menu.

### Program Type (PTY) News

When the PTY news mode is activated and the radio receives a PTY news code from the FM broadcasting news station, the actual playing mode will be interrupted by the FM broadcasting news station. Once the news broadcast is finished the unit returns to the previous mode.

### NOTE:

In some countries or regions, this service is not

available or the signal is too weak to receive.

To activate the PTY news function press the TA button for more than 2 seconds during FM mode. The display indicates PTY news for 3 seconds and a PTY icon.

### 1. PTY news seek

The radio enters PTY news seek mode by pressing the seek up/down (<< or >>) tuning button within 5 seconds after activating the PTY news function.

If the radio catches the desired PTY news station, the PTY NEWS appears on the display for 3 seconds and followed by the station name.

### 2. PTY news standby mode

- The PTY news standby mode can be activated in FM or CD mode.
- A PTY news interruption will be announced and the PTY NEWS will be displayed for 3 seconds, when the radio detects the same PTY news code between PTY news standby mode and the tuned station or EON stations. The display will then change to the PTY name of the interrupting station.
- When pressing the TA button for more than 2 seconds, the PTY news standby mode is switched off and PTY news icon disappears from the display.

### 3. PTY news interruption mode

- When the TA button is pressed during a PTY news interruption, the radio returns to the previous source. However, PTY news standby mode is kept.
- When the SRC button is pressed during a PTY news interruption, the radio changes to the CD mode. However, PTY news standby mode is kept.

If the radio band changes to the MW or LW, then the PTY news standby mode will be switched off.

#### User set up menu:

Push the power switch while pressing and holding the FM button.

Each time the  $\wedge$  or  $\vee$  button is pressed, TA VOL(ume) or ON VOL are selected.

Pressing the  $\gg$  or  $\ll$  button changes the volume level up or down respectively. After the desired levels have been set, the settings are memorized by pressing the power switch.

#### Auto retune:

If the last tuned station does not broadcast RDS/EON data while in CD mode, the radio will automatically retune to a station providing RDS/EON data. When the unit is returned to the radio mode, the previous station is selected.

Auto tuning is performed in the following cases:

- When no RDS data is received for over 25 seconds when the AF mode is on and the TA mode is off.
- When a traffic announcement interruption station cannot be received for over 25 seconds when the AF mode is off and the TA mode is on.
- When traffic announcement interruption RDS station cannot be received for over 25 seconds when both the AF and TA modes are on.

#### Compact disc (CD) player operation

Turn the ignition switch to the ACC or ON position and insert the compact disc into the slot with the label side facing up. The compact disc will be guided automatically into the slot and start playing.

If the radio is already operating, it will automatically turn off and the compact disc will play.

#### CAUTION:

**Do not force the compact disc into the slot. This could damage the player.**

$\ll$   $\gg$  **Track up/down:**

Press  $\gg$  button to change to the beginning of the next track. Sound is muted during this op-

eration and play resumes automatically.

Press the  $\ll$  button to change to the beginning of the current track. Sound is muted during this operation and play resumes automatically.

If either the  $\gg$  or  $\ll$  button is held for longer than 2 seconds, the track will continuously fast-forward (or rewind) with the audio output muted, until the button is released.

$\blacktriangle$  **CD EJECT:**

Press the eject button  $\blacktriangle$  to eject the compact disc.

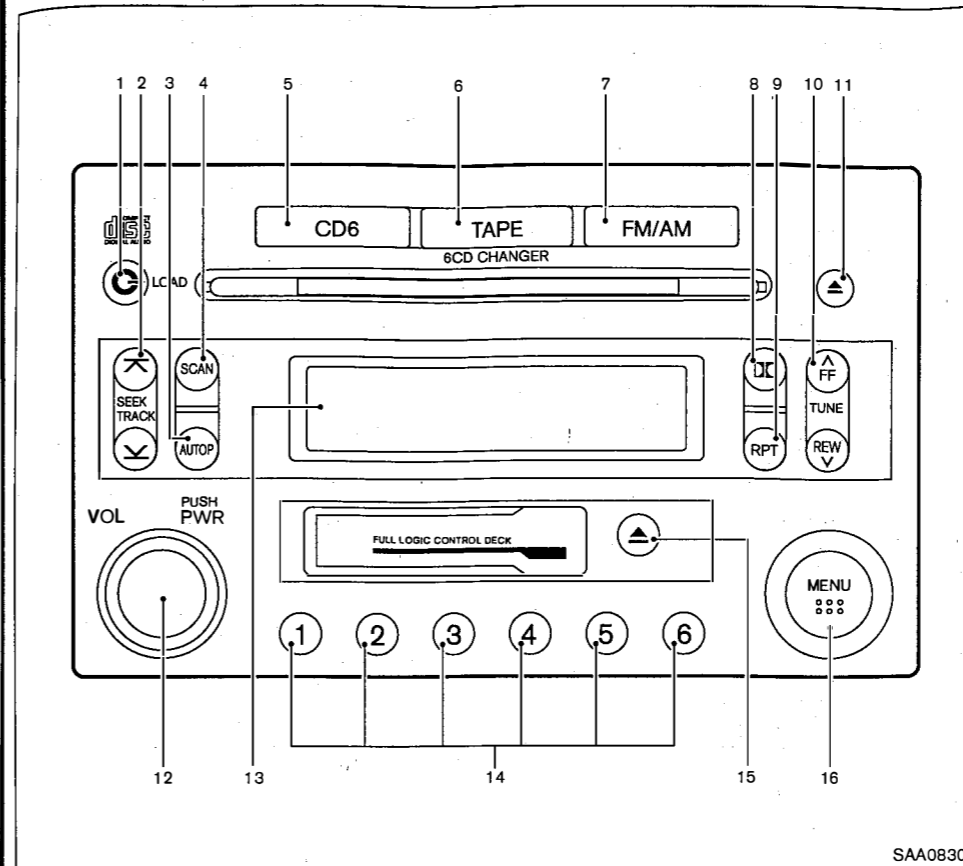

### FM-AM RADIO WITH CASSETTE TAPE PLAYER AND COMPACT DISC (CD) CHANGER

1. CD LOAD button
2. SEEK/APS REW, APS FF/TRACK ADJUSTING button
3. AUTOP (Automatic preset) button
4. SCAN tuning button
5. CD PLAY button
6. TAPE PLAY button
7. Radio band select button
8. DOLBY button
9. RPT (Repeat) play button
10. RADIO TUNE/FF-REW/AUDIO (Bass, treble, fader, balance) ADJUSTING button
11. CD EJECT button
12. ON-OFF/VOL (Volume) control knob
13. Audio/Clock display
14. Station and preset (radio)/CD insert or CD play select button
15. TAPE EJECT button
16. MENU (Bass, treble, fader, balance, clock) button

SAA0830

## Audio main operation

### Head unit:

The tape deck employs a permalloy head which allows for improved reproduction of high frequency ranges. Noise is also greatly reduced by the combined use of the Dolby NR (Noise Reduction) system. The auto loudness circuit enhances the low frequency range automatically in both radio reception and tape and CD playback.

### ON-OFF/Volume control:

Turn the ignition key to ACC or ON, and then push the ON-OFF/VOL (Volume) control knob while the system is off to call up the mode (radio, tape or CD) which was playing immediately before the system was turned off. When no CD or tape is loaded, the radio will come on. While the system is on, pushing the ON-OFF/VOL control knob turns the system off.





To turn the radio off, press the ON-OFF/VOL control knob.





Turn the ON-OFF/VOL control knob to adjust the volume.

### MENU button:

Press the MENU button to change the selecting mode as follows.

BASS → TREBLE → FADER → BALANCE →  
CLOCK ON/OFF (→ clock adjustment mode)

To adjust Bass, Treble, Fader and Balance, press the MENU button until the desired mode (BASS, TREBLE, FADER or BALANCE) appears in the display. Press the TUNE (  ,  ) or SEEK (  ,  ) button to adjust Bass and Treble to the desired level. Use the TUNE or SEEK button also to adjust Fader or Balance modes. Fader adjusts the sound level between the front and rear speakers and Balance adjusts the sound between the right and left speakers.



AUDIO MODE	AUDIO CONTROL ADJUSTING BUTTON		
	 or 	Center position	 or 
BASS (bass adjustment)	BAS -5	BAS 0	BAS +5
TREBLE (treble adjustment)	TRE -5	TRE 0	TRE +5
FADER (front/rear balance adjustment)	FAD R 5 (FADER Rear)	FAD 0	FAD F 5 (FADER Front)
BALANCE (left/right balance adjustment)	BAL L 5 (BALANCE Left)	BAL 0	BAL R 5 (BALANCE Right)

For clock adjustment, see "Clock" in the "Instruments and controls" section.

Once you have adjusted the sound quality to the desired level, press the MENU button repeatedly until the radio, cassette tape or CD display reappears. Otherwise, the radio, cassette tape or CD display will automatically reappear after about 10 seconds.

### Frequency range and step change operations (for Central/South America):

The frequency range and step of this radio can be changed to the Central/South American specification. To change the frequency range and step, proceed as follows:

1. Turn the audio unit once.
2. Push and hold the station select buttons 3, 4 and the TUNE down button .
3. Turn the audio unit on while the station select buttons 3, 4 and the TUNE down button  are being pushed. AM 530 is displayed.

The frequency range and step have now been changed to the Central/South American specification.

## Radio operation

### Radio band select:

Pushing the FM/AM button will change the band as follows:

AM → FM1 → FM2 → AM

When FM/AM button is pushed while the ignition switch is in the ACC or ON position, the radio will come on at the station last played.

The last station played will also come on when the ON-OFF/VOL control knob is pushed to ON.



If a compact disc or tape is playing when the FM/AM button is turned to ON, the compact disc or tape will automatically be turned off and the last radio station played will come on.

The FM stereo indicator ST will glow during FM stereo reception. When the stereo broadcast signal is weak, the radio will automatically change from stereo to monaural reception.

### TUNE (Tuning):



#### WARNING:

**The radio should not be tuned while driving so full attention may be given to vehicle operation.**

Use the TUNE button  or  for manual tuning. To move quickly through the channels,

hold either side of the TUNE button down for more than 0.5 second.

### SEEK tuning:

Pushing the SEEK button  or  tunes from high to low or low to high frequencies and stops at the next broadcasting station.

### SCAN tuning:

Pushing the SCAN tuning button tunes from low to high frequencies and stops at each broadcasting station for 5 seconds. Pushing the button again during this 5 second period will stop SCAN tuning and the radio will remain tuned to that station.

If the SCAN tuning button is not pushed within 5 seconds, SCAN tuning moves to the next station.

### Station memory operations:

Twelve stations can be set for the FM band (six for FM1, six for FM2) and six stations can be set for both the AM bands.

1. Tune to the desired station using the SEEK, SCAN or TUNE button.
2. Select the desired station and keep pushing any of the desired station/preset buttons (1 to 6) until a beep sound is heard. (The radio mutes when the station/preset button is pushed.)

3. The channel indicator will then come on and the sound will resume. Memorizing is now complete.

4. Other buttons can be set in the same manner.

**If the battery cable is disconnected, or if the fuse blows, the radio memory will be erased. In that case, reset the desired stations.**

### Automatic preset button:

To select the preset FM or AM, push the AUTOP button for less than 1.5 seconds.

To preset the station frequency automatically, push the AUTOP button for more than 1.5 seconds.

## Cassette tape player operation

Turn the ignition key to the ACC or ON position, and then lightly insert the cassette tape into the tape door. The cassette tape will be automatically pulled into the player. The radio or CD will turn off (if it is on) and the cassette tape will begin to play.

### CAUTION:

**Do not force the cassette tape into the tape door. This could cause player damage.**

If the system is turned off by pushing the ON-OFF/VOL control knob with the cassette





tape still in the player, the tape will resume playing when the system is turned back on.

#### TAPE PLAY:

- When the TAPE button is pushed with the system turned off and a tape loaded, the system will come on and the tape will play.
- When the TAPE button is pushed with either the radio or compact disc turned on and the tape loaded, the compact disc or the radio will automatically be turned off and the tape will play.
- When the TAPE button is pushed with the TAPE playing, the tape will play the program recorded on the reverse side.





**FF (Fast Forward), REW (Rewind):**



Push the  (fast forward) button to fast forward the tape. To rewind the tape, push the  (rewind) button. Either the FF or REW symbol illuminates on the right side of the display window. To stop the FF or REW function, press the  (fast forward) or  (rewind) again, or the TAPE button.



**APS (Automatic Program Search) FF, APS REW:**

When the  (APS FF) button is pushed while the tape is being played, the next program will start to play from the beginning. Push the

 (APS FF) button several times to skip through programs. The tape will advance the number of times the button is pushed (up to nine programs).

When the  (APS REW) button is pushed once, the program being played starts over from the beginning. Push the  (APS REW) button several times to skip back several selections. The tape will go back the number of times the button is pushed. Either the FF or REW symbol flashes on the display window while searching for the selection.

This system searches for the blank intervals between selections. If there is a blank interval within one program or there is no interval between programs, the system may not stop in the desired or expected location.

#### SCAN SCAN tuning:

Push the SCAN tuning button while playing a tape, and it stops at the next tape program for 5 seconds. Pushing the button again during this 5 second period will stop SCAN tuning and the tape program is continued. If the SCAN tuning button is not pushed within 5 seconds, SCAN tuning moves to the next tape program.

#### Dolby NR (Noise Reduction):

Push the Dolby NR  button for Dolby NR encoded tapes to reduce high frequency tape

noise. The indicator will come on.

Dolby noise reduction is manufactured under license from Dolby Laboratories Licensing Corporation. Dolby NR and the double-D symbol  are trademarks of Dolby Laboratories Licensing Corporation.

#### Metal or chrome tape usage:

The cassette player will be automatically set to high performance play when playing a metal or chrome cassette tape.



**TAPE EJECT:**

When this button is pushed with the tape loaded, the tape will be ejected.

When the tape is ejected while it is being played, the system will be turned off.

#### Compact disc (CD) changer operation

Turn the ignition key to the ACC or ON position, push the LOAD button and insert the compact disc into the slot with the label side facing up. The compact disc will be guided automatically into the slot and start playing.

After loading the disc, the number of tracks on the disc will appear on the display.

If the radio or tape is already operating, it will automatically turn off and the compact disc will play.

#### CAUTION:

- Do not force the compact disc into the slot. This could damage the player.
- Do not use 8 cm (3.1 in) discs.

If the system has been turned off while the compact disc was playing, pushing the ON-OFF/VOL control knob will start the compact disc.

#### LOAD CD LOAD:

To insert a CD in the CD changer, push the LOAD button for less than 1.5 seconds. Select the loading slot by pushing the CD insert select button (1 to 6), then insert the CD.

To insert 6 CDs to the CD changer in succession, push the LOAD button for more than 1.5 seconds.

The inserted slot numbers will illuminate on the display.

#### CD6 CD PLAY:



When the CD6 (CD play) button is pushed with the system off and the compact disc loaded, the system will turn on and the compact disc will start to play.

When the CD6 button is pushed with the compact disc loaded with the tape or the radio playing, the tape or radio will automatically be

turned off and the compact disc will start to play.





**FF (Fast Forward), REW (Rewind):**

When the  (fast forward) or  (rewind) button is pushed while the compact disc is being played, the compact disc will play while fast forwarding or rewinding. When the button is released, the compact disc will return to normal play speed.



**APS (Automatic Program Search) FF, APS REW:**

When the  (APS FF) button is pushed while the compact disc is being played, the next program from the present one will start to play from its beginning. Push several times to skip through programs. The compact disc will advance the number of times the button is pushed. (When the last program on the compact disc is skipped through, the first program will be played.) When the  (APS REW) button is pushed, the program being played returns to its beginning. Push several times to skip back through programs. The compact disc will go back the number of times the button is pushed.

#### CD PLAY select button:

To change CD, push the CD play select button (1 to 6).

#### SCAN SCAN tuning:

When the SCAN tuning button is pushed for less than 1.5 seconds while the CD is being played, the beginning of all the CD programs in each track will be played for 10 seconds in sequence.

When the SCAN tuning button is pushed for more than 1.5 seconds while the CD is being played, the first program in all the CDs will be played for 10 seconds.

Pushing the button again during this 10 second period will stop SCAN tuning.

If the SCAN tuning button is not pushed within 10 seconds, SCAN tuning moves to the next disc program.

#### RPT REPEAT (RPT):

When the RPT play button is pushed while the compact disc is being played, the play pattern can be changed as follows:

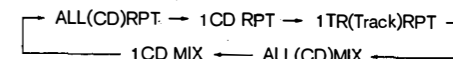

The display shows the following symbols.

(no mark): ALL CD RPT (Repeat)

1DISC: 1 CD RPT

1: 1 TR (Track) RPT

MIX: ALL CD MIX

1DISC MIX: 1 CD MIX



#### CD EJECT:

When the CD EJECT button is pushed with the compact disc loaded, the compact disc will be ejected.

To eject the disc selected by the CD select button, push the EJECT button for less than 1.5 seconds.

To eject all the discs in succession, push the EJECT button for more than 1.5 seconds.

When this button is pushed while the compact disc is being played, the compact disc will come out and the system will turn off.

**If the compact disc comes out and is not removed, it will be pulled back into the slot to protect it.**

#### CD IN indicator:

CD IN indicator (inserted slot number) appears on the display when the CD is loaded with the system on.

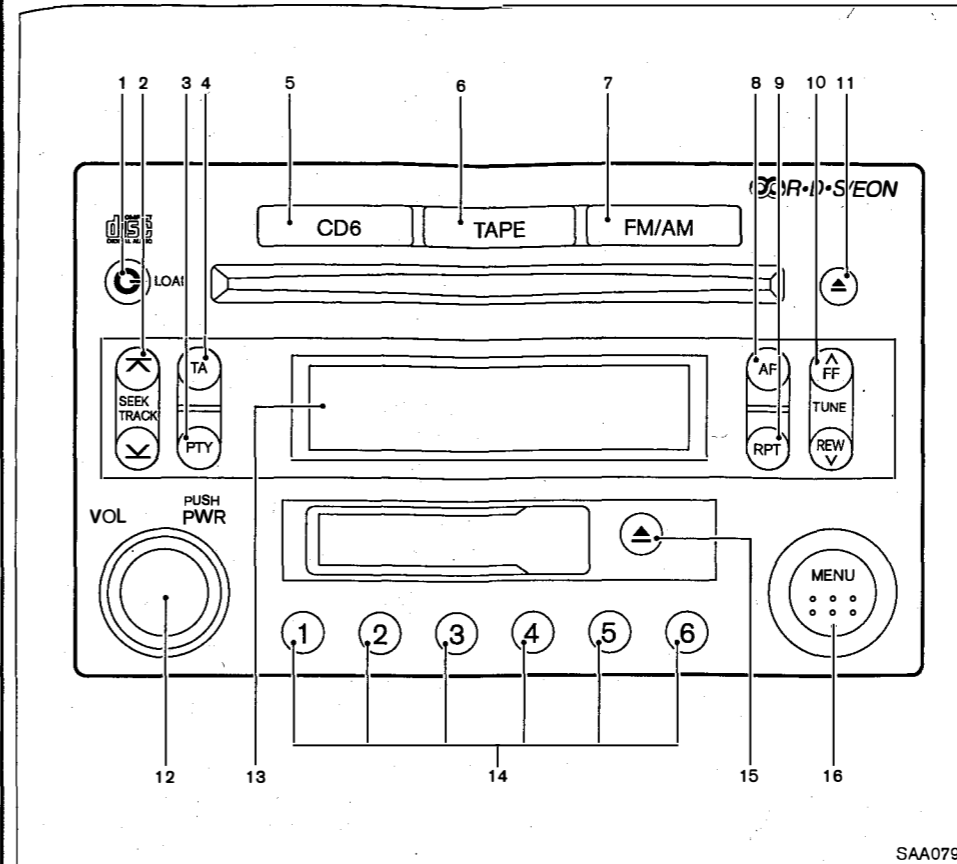

#### LW-MW-FM RADIO WITH CASSETTE TAPE PLAYER AND COMPACT DISC (CD) CHANGER

1. CD LOAD button
2. SEEK/APS REW, APS FF/TRACK ADJUSTING button
3. PTY (Program type) button
4. TA (Traffic announcement) button
5. CD PLAY button
6. TAPE PLAY button
7. Radio band select button
8. AF (Alternative frequency) button
9. RPT (Repeat) play button
10. RADIO TUNE/FF-REW/AUDIO (Bass, treble, fader, balance, SSV\* and Dolby) ADJUSTING button
11. CD EJECT button
12. ON-OFF/VOL (Volume) control knob
13. Audio display
14. Station and preset (radio)/CD insert or CD play select button
15. TAPE EJECT button
16. MENU (Bass, treble, fader, balance, SSV\*, and Dolby) button

\*: if so equipped



This unit is an electronic LW-MW-FM radio with cassette player and CD player with an anti-theft system and traffic announcement function.

Anti-theft system (without personal code)

This unit can only be activated when the ignition key for NATS is in the ACC or ON position.

Each radio is uniquely matched to the vehicle's immobilizer and therefore cannot be transferred to any other vehicle.

Anti-theft system (with personal code)

By using a personal 4-digit code known only to the vehicle owner, the possibility of the audio unit being stolen is effectively reduced, because without the code, the unit cannot be activated. When used normally, the unit is unlocked and accessible in the usual way.

If however, force is used to try and remove the unit, the anti-theft system activates and the unit locks. The only way it can be unlocked is by entering the personal code number known only by the owner. This code number cannot be altered and applies only to your vehicle. This code number is shown on a radio pass card. The radio pass card is installed in the glove box at the vehicle production site. Ask a NISSAN dealer for the location of your radio pass card.

**WARNING:**

**Keep the radio pass card in a safe place and refrain from keeping it in the vehicle. Contact a NISSAN dealer if you lose the radio pass card or forget the code number of your radio.**

**Unlocking the unit:**

**Read this section very carefully. It is important that the instructions are followed precisely.**

If the battery supply to the vehicle is interrupted by accident for some reason, the unit will lock.

To unlock the unit, proceed as follows:

1. Press the power/volume control knob to turn the unit on.
2. CODE IN is displayed.
3. Input your personal code by pressing the preset buttons (1 to 4).
4. Press the  $\wedge$  button.
5. If the entered code number is correct, the radio turns on. A radio frequency appears on the display.
6. If the entered code is incorrect, the unit becomes inoperable for 10 seconds for the first three attempts, then the code input mode is automatically set (CODE IN is displayed).

7. If the code is incorrect the fourth time, the unit becomes inoperable for 60 minutes and (----) is displayed. After 60 minutes, the code input mode is automatically set (CODE IN is displayed). If the above is repeated 17 times, the unit will lock permanently and you will need to contact a NISSAN dealer.

**Audio main operation**

**Head unit:**

The tape deck employs a permalloy head which allows for improved reproduction of high frequency ranges. Noise is also greatly reduced by the combined use of the Dolby NR (Noise Reduction) system. The auto loudness circuit enhances the low frequency range automatically in both radio reception and tape and CD playback.

**ON-OFF/Volume control:**

Turn the ignition key to ACC or ON, and then push the ON-OFF/VOL (Volume) control knob while the system is off to call up the mode (radio, tape or CD) which was playing immediately before the system was turned off. When no CD or tape is loaded, the radio will come on. While the system is on, pushing the ON-OFF/VOL control knob turns the system off.

Turn the ON-OFF/VOL control knob to adjust the volume. If your vehicle is equipped with

**Speed Sensitive control Volume (SSV)**, the audio volume will change as the driving speed changes.

**MENU button:**

Press the MENU button to change the selecting mode as follows.

BASS → TREBLE → FADER → BALANCE → SSV (if so equipped) → NR (when cassette is playing)

To adjust Bass, Treble, Fader and Balance, press the MENU button until the desired mode (BASS, TREBLE, FADER or BALANCE) appears in the display. Press the TUNE ( $\vee$ ,  $\wedge$ ) or SEEK ( $\searrow$ ,  $\nearrow$ ) button to adjust Bass and Treble to the desired level. Use the TUNE or SEEK button also to adjust Fader or Balance modes. Fader adjusts the sound level between the front and rear speakers and Balance adjusts the sound between the right and left speakers.

AUDIO MODE	AUDIO CONTROL ADJUSTING BUTTON		
	$\vee$ or $\searrow$	Center position	$\wedge$ or $\nearrow$
BASS (bass adjustment)	BAS -5	BAS 0	BAS +5
TREBLE (treble adjustment)	TRE -5	TRE 0	TRE +5
FADER (front/rear balance adjustment)	FAD R 5 (FADER Rear)	FAD 0	FAD F 5 (FADER Front)
BAL-ANCE (left/right balance adjustment)	BAL L 5 (BALANCE Left)	BAL 0	BAL R 5 (BALANCE Right)

To change the SSV mode to OFF, LOW, MID or HIGH, press the  $\vee$  or  $\wedge$  (TUNE) button. (if so equipped)

To change the NR (Dolby) mode to OFF or ON, press the  $\vee$  or  $\wedge$  (TUNE) button while cassette tape is playing. When Dolby is ON, the display indicates the  $\square\square$  mark.

Once you have adjusted the sound quality to the desired level, press the MENU button repeatedly until the radio, cassette tape or CD display reappears. Otherwise, the radio, cassette tape

or CD display will automatically reappear after about 10 seconds.

**Radio operation**

**FM/AM Radio band select/Auto store:**

Pushing the FM/AM button will change the band as follows:

FM → FM (AS) → MW → LW

When FM/AM button is pushed while the ignition switch is in the ACC or ON, the radio will come on at the station last played.

The last station played will also come on when the ON-OFF/VOL control knob is pushed to ON.

If a compact disc or tape is playing when the FM/AM button is turned to ON, the compact disc or tape will automatically be turned off and the last radio station played will come on.

During FM reception, when the FM/AM button is pressed for more than 1.5 seconds, stations are searched for automatically and the six stations with the strongest signals are automatically stored on FM.

The sound is muted until the auto store operation is completed, upon which preset channel 1 is automatically tuned in.





**TUNE (Tuning):**



**WARNING:**



The radio should not be tuned while driving so full attention may be given to vehicle operation.

Use the TUNE button  or  for manual tuning. To move quickly through the channels, hold either side of the TUNE button down for more than 0.5 second.

The frequency changes in steps of 100 kHz on the FM band, 9 kHz on the MW band, and 3 kHz on the LW band.



**SEEK tuning:**

When adjusting the broadcasting station frequency automatically, push the SEEK button  or . When the system detects a broadcasting station, it will stop at the station.

#### Station memory operations:

Twelve stations can be set for the FM band (six for FM, six for FM-AS) and six stations can be set for both the MW and LW bands.

1. Tune to the desired station using the SEEK or TUNE button.
2. Select the desired station and keep pushing any of the desired station/preset buttons (1 to 6) until a beep sound is heard. (The radio

mutes when the station/preset button is pushed.)

3. The channel indicator will then come on and the sound will resume. Memorizing is now complete.
4. Other buttons can be set in the same manner.

**If the battery cable is disconnected, or if the fuse blows, the radio memory will be erased. In that case, reset the desired stations.**

#### Radio data system (RDS)

##### Alternative Frequency (AF):

The AF function operates in the FM (radio) mode.

- When the AF button is pressed for less than 1.5 seconds, the AF function and the AF indicator turn on or off.
- When the AF button is pressed for more than 1.5 seconds, the REG (Region) function operates.

The following functions operate when the AF mode is on:

##### • Automatic switching function

This function compares the strengths of the signals of the stations on the AF (alternative frequency list) and selects the station with

the optimum reception conditions.

##### • Program information (PI) search

Program Information (PI) search begins automatically if no suitable station is found with the above auto switching follow function. The PI search function checks each RDS station with the same PI code. During this time the sound is muted and SEARCH is displayed. The PI search operation stops when a suitable station is found. If no station is found once all the frequencies have been searched, the radio returns to the previous frequency.

##### • Enhanced Other Network (EON) data update (This function also operates when the AF mode is off.)

When EON data is being received, this enables automatic retuning of other preset stations on the same network. Also, network linked services can be used.

#### RDS functions:

##### • Programme Service (PS) function (station name display function)

When an RDS station is tuned in with seek or manual tuning, the RDS data is received and the PS name is displayed immediately.

##### • Emergency broadcast interrupt function (ALARM INTERRUPTION — EBU SPEC FOR INFO)

When the radio receives PTY code 31 (an emergency broadcast code), the sound is interrupted, the emergency broadcast is heard, and PTY31 ALARM is displayed. The volume level at this time is the same as that for traffic announcements. Once the emergency broadcast is finished, the unit immediately returns to the previous source.

##### • REG (Regional) mode

This mode is turned on and off by pressing the AF button for more than 1.5 seconds during the FM mode. When the mode is turned on, the REG indicator comes on and all bits of the PI code are checked during the auto follow operation.

When the mode is turned off, the REG indicator turns off and all bits of the PI code except the area code are checked during the auto follow operation. When the same preset channel is called out while a regional station is tuned and the REG mode is off, another station in the same network is selected, if available.

#### Traffic announcement (TA):

- The TA function operates in the FM, tape and CD modes.

- The TA mode is selected when the TA button is pressed.

- The TA mode operates regardless of whether the AF mode is on or off.

- TA ON is displayed when the TA mode is turned on, and the TA indicator comes on. TA OFF is displayed when the TA mode is turned off, and the TA indicator turns off.

The following functions operate when the TA mode is on:

##### • Traffic announcement interrupt function

When a traffic announcement is received, the announcement is tuned in and the volume increases to the set level. TRAFFIC INFO is displayed.

Once the traffic announcement is finished, the unit returns to the source which was set before the traffic announcement started, and the volume returns to the previous level. For EON stations, the radio is interrupted by another EON station with traffic announcements.

The traffic announcement interrupt mode is cancelled if the TA button is pressed during a traffic announcement. The TA mode returned to the stand-by mode.

##### • Traffic announcement seek

The Traffic Programme (TP) seek mode is set

when the TA button is pressed when a station other than one broadcasting traffic announcements is tuned in. If no station providing traffic announcements (TP stations) is found once all the frequencies have been searched, the radio will return to the station tuned in before the TP seek mode was set.



#### PTY Program type:



When PTY button is pressed for less than 1.5 seconds during FM mode, the PTY name of the current tuned station is displayed. During this time if the PTY data code is zero, or the data is unreadable; the display will show NONE.

When this button is pressed for longer than 1.5 seconds during FM mode, the last preselected PTY name will be displayed for 3 seconds, and the radio enters the PTY selection mode.

#### 1. PTY selection mode

The PTY name can be selected and after 5 seconds of no key operation, the radio goes into the PTY interruption standby mode and the PTY name or frequency is displayed.

PTY name selection can be done by the TUNE button  or  in the PTY selection mode.

It is possible to shift the PTY name by one step, with one push of the TUNE button  or . If the TUNE button is pressed

for more than 0.5 second, the PTY name will step forwards or backwards sequentially every 0.5 second, until the TUNE button is released.

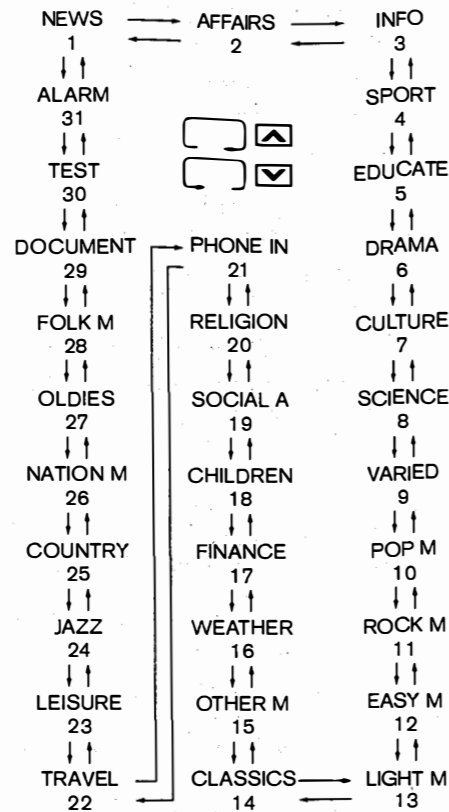

PTY name selection can also be achieved by pressing the preset buttons.

Initial PTY names are stored in the preset buttons; but these can be changed by pressing the preset buttons for more than 2 seconds when the desired PTY name is in the display.

### 2. PTY seek mode

The PTY news seek mode is selected by pressing the SEEK button or . During the PTY seek, the display indication will change cyclically every second between SEARCH PTY and the corresponding program type.

If the radio receives the desired PTY news station, the PTY name appears on the display for 3 seconds.

### 3. PTY standby mode

- The PTY standby mode can be activated in FM, tape and CD mode.
- A PTY interruption will be announced with a beep sound and the PTY name will be displayed for 3 seconds, when the radio detects the same PTY code between PTY standby mode and the tuned station or EON stations. The display will then change to the PTY name of the interrupting station.
- When pressing the PTY button for less than

1.5 seconds, the PTY standby mode is switched off and PTY indicator disappears from the display.

### 4. PTY interruption mode

When the PTY button is pressed during a PTY interruption mode, the radio returns to the previous source. However, PTY interruption standby mode is kept.

### Auto retune:

In the tape or CD mode, if the last tuned station does not broadcast RDS/EON data, the radio is automatically tuned to a station providing RDS/EON data. When the unit is returned to the radio mode, the previous station is selected.

Auto tuning is performed in the following cases:

- When no RDS data is received for over 25 seconds when the AF mode is on and the TA mode is off.
- When a traffic announcement interruption station cannot be received for over 25 seconds when the AF mode is off and the TA mode is on.
- When a traffic announcement interruption RDS station cannot be received for over 25 seconds when both the AF and TA modes are on.

### Cassette tape player operation

Turn the ignition key to ACC or ON, and then lightly insert the cassette tape into the tape door. The cassette tape will be automatically pulled into the player.

The radio or CD will turn off (if it is on) and the cassette tape will begin to play.

### CAUTION:

**Do not force the cassette tape into the tape door. This could cause player damage.**

If the system is turned off by pushing the ON-OFF/VOL control knob with the cassette tape still in the player, the tape will resume playing when the system is turned back on.

### TAPE PLAY:

- When the TAPE button is pushed with the system turned off and a tape loaded, the system will come on and the tape will play.
- When the TAPE button is pushed with either the radio or compact disc turned on and the tape loaded, the compact disc or the radio will automatically be turned off and the tape will play.
- When the TAPE button is pushed with the TAPE playing, the tape will play the program recorded on the reverse side.



Push the (fast forward) button to fast forward the tape. To rewind the tape, push the (rewind) button. Either the FF or REW symbol illuminates on the right side of the display window. To stop the FF or REW function, press the (fast forward) or (rewind) again, or the TAPE button.

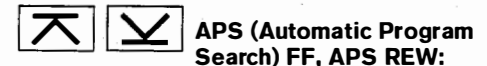

When the (APS FF) button is pushed while the tape is being played, the next program will start to play from the beginning. Push the (APS FF) button several times to skip through programs. The tape will advance the number of times the button is pushed (up to nine programs).

When the (APS REW) button is pushed once, the program being played starts over from the beginning. Push the (APS REW) button several times to skip back several selections. The tape will go back the number of times the button is pushed. Either the FF or REW symbol flashes on the display window while searching for the selection.

This system searches for the blank intervals between selections. If there is a blank interval within one program or there is no interval be-

tween programs, the system may not stop in the desired or expected location.

#### Dolby NR (Noise Reduction):

Dolby noise reduction is manufactured under license from Dolby Laboratories Licensing Corporation. Dolby NR and the double-D symbol  are trademarks of Dolby Laboratories Licensing Corporation.

#### Metal or chrome tape usage:

The cassette player will be automatically set to high performance play when playing a metal or chrome cassette tape.



#### TAPE EJECT:

When this button is pushed with the tape loaded, the tape will be ejected.

When the tape is ejected while it is being played, the system will be turned off.

#### Compact disc (CD) changer operation

Turn the ignition key to the ACC or ON position, push the LOAD button and insert the compact disc into the slot with the label side facing up. The compact disc will be guided automatically into the slot and start playing.

After loading the disc, the number of tracks on the disc will appear on the display.

If the radio or tape is already operating, it will

automatically turn off and the compact disc will play.

#### CAUTION:

- Do not force the compact disc into the slot. This could damage the player.

- Do not use 8 cm (3.1 in) discs.

If the system has been turned off while the compact disc was playing, pushing the ON-OFF/VOL control knob will start the compact disc.

#### LOAD CD LOAD:

To insert a CD in the CD changer, push the LOAD button for less than 1.5 seconds. Select the loading slot by pushing the CD insert select button (1 to 6), then insert the CD.

To insert 6 CDs to the CD changer in succession, push the LOAD button for more than 1.5 seconds.

The inserted slot numbers will illuminate on the display.

#### CD6 CD PLAY:



When the CD6 (CD play) button is pushed with the system off and the compact disc loaded, the system will turn on and the compact disc will start to play.

When the CD6 button is pushed with the com-

compact disc loaded with the tape or the radio playing, the tape or radio will automatically be turned off and the compact disc will start to play.





#### FF (Fast Forward), REW (Rewind):

When the  (fast forward) or  (rewind) button is pushed while the compact disc is being played, the compact disc will play while fast forwarding or rewinding. When the button is released, the compact disc will return to normal play speed.



#### APS (Automatic Program Search) FF, APS REW:

When the  (APS FF) button is pushed while the compact disc is being played, the program next to the present one will start to play from its beginning. Push several times to skip through programs. The compact disc will advance the number of times the button is pushed. (When the last program on the compact disc is skipped through, the first program will be played.) When the  (APS REW) button is pushed, the program being played returns to its beginning. Push several times to skip back through programs. The compact disc will go back the number of times the button is pushed.

#### CD PLAY select button:

To change CD, push the CD play select button (1 to 6).

#### RPT REPEAT (RPT):

When the RPT play button is pushed while the compact disc is played, the play pattern can be changed as follows:

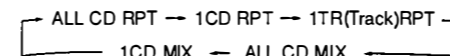

The display shows the following symbols.

(no mark): ALL CD RPT (Repeat)

1DISC: 1 CD RPT

1: 1 TR (Track) RPT

MIX: ALL CD MIX

1DISC MIX: 1 CD MIX



#### CD EJECT:

When the CD EJECT button is pushed with the compact disc loaded, the compact disc will be ejected.

To eject the disc selected by the CD select button, push the EJECT button for less than 1.5 seconds.

To eject all the discs in succession, push the EJECT button for more than 1.5 seconds.

When the EJECT button is pushed while the compact disc is being played, the compact disc will come out and the system will turn off.

If the compact disc comes out and is not removed, it will be pulled back into the slot to protect it.

If either of the following messages appear on the display, push the EJECT button:

- PUSH EJECT — Eject the disc, and insert it again.
- CHECK DISC — Eject the disc, and check whether it is inserted upside-down or damaged.

#### CD IN indicator:

CD IN indicator (inserted slot number) appears on the display when the CD is loaded with the system on.

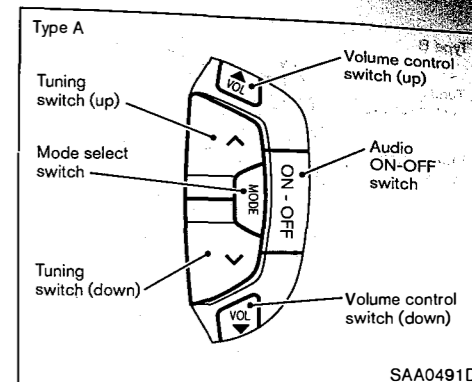

#### STEERING SWITCH FOR AUDIO CONTROL (if so equipped)

The audio system can be operated using the controls on the steering wheel. The availability of the steering switch functions depends on each audio unit.

#### Audio ON-OFF switch (for type A)

With the ignition switch turned to the ACC or ON position, push the ON-OFF switch to turn the audio system on or off.



#### Special switch (for type B)

Each time the special switch is pushed in the radio mode, the preset station (1 to 6) on each band (FM, MW or LW) is selected. To change

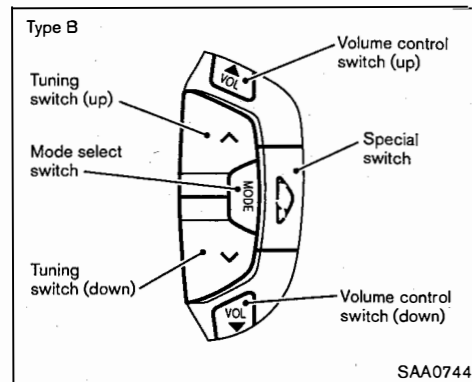

the band, use the FM/AM (radio band select) button of the radio.

#### Mode select switch

Push the mode select switch to change the mode in the sequence of radio (each band), tape, CD player/changer (if so equipped). When the tape or CD (in the player and/or changer) is loaded, the mode changes to tape or CD.

#### Volume control switch

Push the upper side or lower side of the switch to adjust the volume.

Upper side: Volume increases

Lower side: Volume decreases

#### Tuning switch (up or down)

##### Memory change (radio):

Push the tuning switch  $\wedge$  or  $\vee$  for less than 1.5 seconds to change the preset radio channels.

##### Seek tuning (radio):

Push the tuning switch  $\wedge$  or  $\vee$  for more than 1.5 seconds to seek the next or previous radio station.

##### APS (Automatic Program Search) FF, APS REW (tape, CD or CD changer):

Push the tuning switch  $\wedge$  or  $\vee$  for less than 1.5 seconds to return to the beginning of the present program or skip to the next program. Push several times to skip back or skip through programs.

This system searches for the blank intervals between selections. If there is a blank interval within one program or there is no interval between programs, the system may not stop in the desired or expected location.

##### FF REW (tape or CD changer):

Push the tuning switch  $\wedge$  or  $\vee$  for more than 1.5 seconds to rewind or fast forward the tape or to change the playing disc up or down.

To stop the FF or REW function, press the

switch you pushed for more than 1.5 seconds again.

## CAR PHONE OR CB RADIO

When installing a CB, ham radio or a car phone in your vehicle, be sure to observe the following cautions, otherwise the new equipment may adversely affect the Engine Control System and other electronic parts.

#### CAUTION:

- Keep the antenna as far away as possible from the Electronic Control Module.
- Keep the antenna wire at least 20 cm (8 in) away from the Engine Control harnesses. Do not route the antenna wire next to any harnesses.
- Adjust the antenna standing wave ratio as recommended by the manufacturer.
- Connect the ground wire from the radio chassis to the body.
- For details, consult a NISSAN dealer.

## 5 Starting and driving

Break-in schedule .....	5-2	<b>4x4</b> Four-wheel drive (4WD) .....	5-18
Before starting the engine .....	5-2	Transfer case shifting procedures .....	5-18
Precautions when starting and driving .....	5-3	Two-way lock free-running hubs .....	5-21
Exhaust gas (carbon monoxide) .....	5-3	Manual-lock free-running hubs .....	5-24
Three way catalyst .....	5-3	<b>4x4</b> Driving four-wheel drive (4WD) safely ....	5-26
Turbocharger system .....	5-4	<b>4x4</b> Tires of four-wheel drive (4WD) .....	5-27
Care when driving .....	5-4	Cruise control .....	5-27
Engine cold start period .....	5-4	Cruise control operations .....	5-28
Loading luggage .....	5-4	Precautions on cruise control .....	5-29
Driving in wet conditions .....	5-4	Parking .....	5-29
Driving in winter conditions .....	5-5	Trailer towing .....	5-31
Ignition switch .....	5-5	Operating precautions.....	5-31
Manual transmission .....	5-5	Maximum load limits (for Australia).....	5-31
Automatic transmission .....	5-6	Tire pressure.....	5-33
Key positions .....	5-6	Safety chains .....	5-33
NISSAN Anti-Theft System (NATS) .....	5-6	Trailer brakes .....	5-33
Starting the engine .....	5-7	Vehicle security .....	5-33
TB45E/TB48DE gasoline engines .....	5-7	Brake system.....	5-33
TB45S gasoline engine (with automatic choke) ....	5-7	Brake precautions .....	5-33
ZD30DDTi diesel engine .....	5-8	Anti-lock braking system (ABS).....	5-34
TD42/TD42Ti diesel engine (with throttle control knob) .....	5-9	Cold weather driving .....	5-35
Driving vehicle .....	5-10	Battery .....	5-35
Driving with manual transmission .....	5-10	Engine coolant .....	5-36
Driving with automatic transmission		Tire equipment .....	5-36
(5-speed models) .....	5-11	Special winter equipment .....	5-36
Driving with automatic transmission		Parking brake .....	5-36
(4-speed models) .....	5-14	Corrosion protection .....	5-36
		Winch .....	5-37
		Precautions on winch .....	5-37
		Winch operation .....	5-38

## BREAK-IN SCHEDULE

During the first 1,600 km (1,000 miles), follow these recommendations for the future reliability and economy of your new vehicle.

- Avoid driving for long periods at constant speed, either fast or slow.
- Do not accelerate at full throttle in any gear.
- Avoid quick starts.
- Avoid hard braking as much as possible.
- Do not tow a trailer for the first 800 km (500 miles).

## BEFORE STARTING THE ENGINE



### WARNING:

The driving characteristics of your vehicle can be changed remarkably by any additional load and its distribution as well as by adding optional equipment (trailer couplings, roof racks, etc.). Your driving style and speed have to be adjusted accordingly. **ESPECIALLY WHEN CARRYING HEAVY LOADS, YOUR SPEED MUST BE REDUCED ADEQUATELY.**

- Make sure the area around the vehicle is clear.
- Check fluid levels such as engine oil, coolant, brake and clutch fluid, and window washer fluid as frequently as possible, at least whenever you refuel.
- Check that all windows and lights are clean.
- Visually inspect tires for their appearance and condition. Also check tire pressure for proper inflation.
- Check that all doors are closed.
- Position seat and adjust head restraints.
- Adjust inside and outside mirrors.
- Fasten seat belts and ask all passengers to do likewise.

- Do not place hard or heavy objects on either the front or rear parcel shelf to prevent injury in the event of a sudden stop.
- Check the operation of warning lights when key is turned to the "ON" position.

## PRECAUTIONS WHEN STARTING AND DRIVING



### WARNING:

- Do not leave children or adults who would normally require the support of others alone in your vehicle. Pets should not be left alone either. They could accidentally injure themselves or others through inadvertent operation of the vehicle. Also, on hot, sunny days, temperatures in a closed vehicle could quickly become high enough to cause severe or possibly fatal injuries to people or animals.
- To prevent luggage or packages from sliding forward during braking, do not stack anything in the cargo area higher than the seatbacks.

### EXHAUST GAS (carbon monoxide)



### WARNING:

- Do not breathe exhaust gases; they contain colorless and odorless carbon monoxide. Carbon monoxide is dangerous. It can cause unconsciousness or death.
- If you suspect that exhaust fumes are entering the vehicle, drive with all windows fully open, and have the vehicle inspected immediately.

- Do not run the engine in closed spaces such as a garage for any longer than is absolutely necessary.
- Do not park the vehicle with the engine running for any extended length of time.
- When a vehicle has been stopped in an open area with its engine running for any significant length of time, turn the ventilator on to force outside air into the vehicle.
- Keep the back door closed while driving, otherwise exhaust gases could be drawn into the passenger compartment. If you must drive in this manner for some reason, take the following steps.
  1. Open all the windows.
  2. Set the air recirculation mode OFF and the fan control at the maximum position to circulate the air.

### THREE WAY CATALYST (if so equipped)

The three way catalyst is an emission control device, installed in the exhaust system. Exhaust gases in the three way catalyst are burned at high temperatures to help reduce pollutants.

### CAUTION:

- The exhaust gas and the exhaust system are very hot. While the engine is running, keep people or flammable materials away from the exhaust pipe.
- Do not stop or park the vehicle over flammable materials such as dry grass, waste paper or rags, as they may burn easily.
- When parking, ensure that people or inflammable materials are kept away from the exhaust pipe.

To help prevent damage

### CAUTION:

- Use UNLEADED GASOLINE ONLY. See "Recommended fuel/lubricants and capacities" in the "9. Technical information" for fuel recommendation. Leaded gasoline will seriously damage catalytic converters.
- Do not use leaded gasoline.

Deposits from leaded gasoline will seriously reduce the catalytic converter's ability to help reduce exhaust pollutants.
- Keep your engine tuned up. Malfunctions in the ignition, carburetion/fuel injection, or

electrical systems can cause overrich fuel flow into the converter, causing it to overheat. **Do not keep driving if the engine misfires, or if noticeable loss of performance or other unusual operating conditions are detected.** Have the vehicle inspected promptly by a NISSAN dealer.

- Avoid driving with an extremely low fuel level. Running out of fuel could cause the engine to misfire, damaging the catalytic converter.
- Do not race the engine while warming it up.
- Do not push or tow your vehicle to start the engine.

### TURBOCHARGER SYSTEM (if so equipped)

The turbocharger system uses engine oil for lubrication and cooling of its rotating components. The turbocharger turbine turns at extremely high speeds and it can reach an extremely high temperature. It is essential to maintain a clean supply of oil flowing through the turbocharger system. Therefore, a sudden interruption of oil supply may cause a malfunction in the turbocharger.

To ensure prolonged life and performance of the turbocharger, it is essential to comply with the following maintenance procedure:

#### CAUTION:

- **Change your engine oil according to the recommended intervals shown in a separate maintenance booklet. Use only the recommended engine oil.**
- **If the engine operated at high rpm for an extended period of time, let it idle for a few minutes prior to shutdown.**
- **Do not accelerate your engine to high rpm immediately after start.**

### CARE WHEN DRIVING

Driving your vehicle to fit the circumstances is essential for your safety and comfort. As a DRIVER, you should be the one who knows best how to drive in the given circumstances.

### ENGINE COLD START PERIOD

Due to the higher engine speeds when the engine is cold, extra caution must be exercised when selecting gear (automatic and manual) during the engine warm-up period after starting the engine.

### LOADING LUGGAGE

Loads and their distribution and the attachment of equipment (coupling devices, roof luggage carriers, etc.) will change the driving characteristics of the vehicle considerably. Driving style and speed must be changed according to the circumstances.

### DRIVING IN WET CONDITIONS

- Avoid starting off, accelerating and stopping suddenly.
- Avoid sharp turns or lane changes.
- Extra distance should be kept from the vehicle in front.
- When water covers the road surface in puddles, small streams, etc, **REDUCE SPEED** to prevent aquaplaning which will

cause skidding and loss of control.

Worn tires increase this risk.

### DRIVING IN WINTER CONDITIONS

- Drive sensitively.
- Avoid sudden steering actions.
- Extra distance should be kept from the vehicle in front.

### IGNITION SWITCH

**To lock the steering wheel, remove the key. To unlock the steering wheel, insert the key and turn it gently while rotating the steering wheel slightly right and left.**



#### WARNING:

**Never remove the key while driving. If the key is removed, the steering wheel will lock. This may cause the driver to lose control of the vehicle and could result in serious vehicle damage or personal injury.**

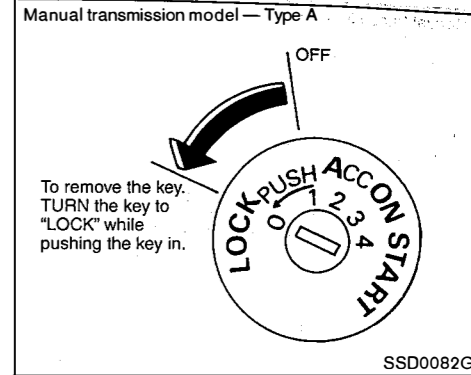

### MANUAL TRANSMISSION

#### Type A

The switch includes an anti-theft steering lock device.

The ignition key can only be removed when the switch is in the LOCK (Normal parking position) (0).

To turn the ignition key to "LOCK" from "ACC" or "ON", first turn the key to "OFF" and turn the key to "LOCK" while pushing the key in.

In order for the steering wheel to be locked, it must be turned about 1/6 of a turn clockwise from the straight up position.



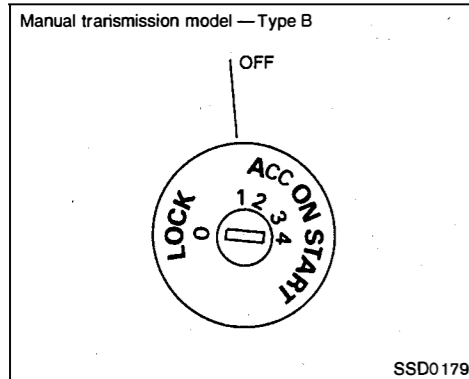

### Type B

The switch is part of the anti-theft steering lock device.

The ignition key can only be removed when the switch is in the LOCK (Normal parking position) (0).

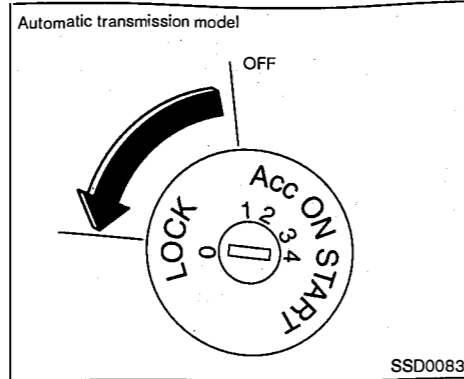

### AUTOMATIC TRANSMISSION

The ignition lock is designed so that the key cannot be turned to "LOCK" and removed until the selector lever is moved to the "P" position.

When removing the key from the ignition, make sure the selector lever is in the "P" position.

In order for the steering wheel to be locked, it must be turned about 1/6 of a turn clockwise from the straight up position.

### KEY POSITIONS

LOCK (Normal parking position) (0):

The ignition key can only be removed at this position.

### OFF (1):

The engine can be turned off without locking the steering wheel.

### ACC (Accessories) (2):

This position activates electrical accessories such as the radio when the engine is not running.

### ON (Normal operating position) (3):

This position turns on the ignition system and the electrical accessories.

### START (4):

This position activates the starter motor, starting the engine.

### NISSAN ANTI-THEFT SYSTEM (NATS)\* (if so equipped)

NATS will stop the engine if someone tries to start the engine without the registered key of NATS.

\*Immobilizer

If the engine fails to start using the registered NATS key, it may be due to interference caused by another NATS key, an automated toll road device or automated payment device on the key ring. Restart the engine using the following procedures:

(Except for TD42/TD42Ti engine models):

1. Leave the ignition switch in the ON position for approximately 5 seconds.
2. Turn the ignition switch to the OFF or LOCK position and wait approximately 5 seconds.
3. Repeat step 1 and 2 again.
4. Restart the engine while holding the device (which may have caused the interference) separate from the registered NATS key.

(For TD42/TD42Ti engine models):

1. Turn the ignition switch to "OFF".
2. Wait for 1 minute. The security indicator light will blink.
3. Turn the ignition switch to "ON" with a registered key. Do not start engine. Wait for 5 seconds.
4. Return the ignition switch to "OFF".
5. Repeat steps (3) and (4) twice (total of three cycles).
6. Start the engine.

If this procedure allows the engine to start, NISSAN recommends placing the registered NATS key on a separate key ring to avoid interference from other devices.

## STARTING THE ENGINE

### TB45E/TB48DE GASOLINE ENGINES

1. Apply the parking brake.
2. **Manual transmission:**

Move the gearshift lever to N (Neutral), and depress the clutch pedal to the floor while cranking the engine.

#### Automatic transmission:

Move the selector lever to P (Park) or N (Neutral). (P preferred)

**The starter is designed not to operate if the selector lever is in one of the driving positions.**

3. Crank the engine **with your foot off the accelerator pedal** by turning the ignition key to START. Release the key when the engine starts. If the engine starts, but fails to run, repeat the above procedure.

If the engine is very hard to start in extremely cold or hot weather, depress the accelerator pedal and hold it to help start the engine.

**Do not crank the engine for more than 15 seconds at a time. If the engine does not start, wait 10 seconds before cranking again, otherwise the starter could be damaged.**

### 4. Warm-up

Always allow the engine to idle for at least 30 seconds after starting. Drive at moderate speed for a short distance first, especially in cold weather.

### TB45S GASOLINE ENGINE (with automatic choke)

1. Apply the parking brake.
2. Move the gearshift lever to N (Neutral), and depress the clutch pedal to the floor while cranking the engine.
3. Start the engine for different conditions as listed below.

**Do not operate the starter for more than 15 seconds at a time. If the engine does not start, wait 10 seconds before cranking again, otherwise the starter could be damaged.**

— Cold engine —

1. Slowly depress the accelerator pedal to the floor and release it.

**DURING COLD WEATHER BELOW -18°C (0°F), FULLY DEPRESS AND RELEASE THE PEDAL TWO OR THREE TIMES.**

2. Crank the engine **with your foot off the**

**accelerator pedal** by turning the ignition key to START. Release the key when the engine starts.

If the engine starts, but fails to run, repeat the above procedure.

3. Allow the engine to idle for about 30 seconds.

4. **TAP THE ACCELERATOR PEDAL TO REDUCE THE ENGINE SPEED. The engine will then warm up at normal speed.**

**Do not leave the vehicle while the engine is warming up.**

— Warm engine —

1. Depress the accelerator pedal about halfway and hold it there. Do not pump the accelerator pedal.

2. Crank the engine by turning the ignition key to START.

3. Release the key and the accelerator pedal when the engine starts.

If the engine is flooded

1. Slowly depress the accelerator pedal to the floor.

2. Keeping the pedal depressed, crank the engine by turning the ignition key to START. If

the engine still does not start, repeat cranking (not over 15 seconds at a time) until the engine is clear of excess fuel.

**Do not pump the accelerator pedal.**

3. When the engine starts, release the pedal gradually as the engine speeds up.

**ZD30DDTi DIESEL ENGINE**

1. Apply the parking brake.

2. **Manual transmission:**

Move the gearshift lever to N (Neutral), and depress the clutch pedal to the floor while cranking the engine.

**Automatic transmission:**

Move the selector lever to P (Park) or N (Neutral). (P preferred)

**The starter is designed not to operate if the selector lever is in one of the driving positions.**

3. Start the engine for different conditions as listed below.

**Do not operate the starter for more than 20 seconds at a time. If the engine does not start, wait 20 seconds before cranking again, otherwise the starter could be damaged.**

— Cold engine (cold weather) —

**[Outside temperature is below 20°C (68°F)]:**

1. Turn the ignition key to ON and wait until the glow indicator light  goes out.

2. Immediately after the glow indicator light goes out, crank the engine by turning the ignition key to START. Release the key when the engine starts.

— Cold engine (not cold weather) —

**[Outside temperature is above 20°C (68°F)]:**

1. Turn the ignition key to ON and wait until the glow indicator light  goes out.

2. Crank the engine by turning the ignition key to START. Release the key when the engine starts.

3. Allow the engine to idle for about 30 seconds.

— Warm engine —

1. Turn the ignition key to ON and wait until the glow indicator light  goes out.

2. Crank the engine by turning the ignition key to START. Release the key when the engine starts.

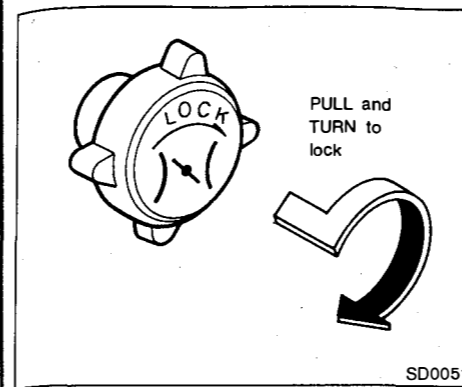

**TD42/TD42Ti DIESEL ENGINE (with throttle control knob)**

1. Apply the parking brake.

2. Move the gearshift lever to N (Neutral), and depress the clutch pedal to the floor while cranking the engine.

3. Start the engine for different conditions as listed below.

**Do not operate the starter for more than 20 seconds at a time. If the engine does not start, wait 20 seconds before cranking again, otherwise the starter could be damaged.**

— Cold engine (cold weather) —

**[Outside temperature is below 0°C (32°F)]:**

1. Turn the ignition key to ON and wait until the glow indicator light  goes out.

2. Immediately after the glow indicator light goes out, fully depress the accelerator pedal and crank the engine by turning the ignition key to START. Release the key and the accelerator pedal when the engine starts.

3. Adjust the throttle control knob until the engine runs smoothly.

4. After the engine has warmed up, turn the throttle control knob counterclockwise to return it to its original position.

● **Proper use of the throttle control knob will reduce start-up smoke.**

● **Do not drive the vehicle with the throttle control knob pulled out.**

— Cold engine (not cold weather) —

**[Outside temperature is above 0°C (32°F)]:**

1. Turn the ignition key to ON and wait until the glow indicator light  goes out.

2. Immediately after the glow indicator light goes out, depress the accelerator pedal halfway and crank the engine by turning the

ignition key to START. Release the key and the accelerator pedal when the engine starts.

3. Adjust the throttle control knob until the engine runs smoothly.

4. After the engine has warmed up, return the throttle control knob to its original position.

● **Do not drive the vehicle with the throttle control knob pulled out.**

— Warm engine —

1. Turn the ignition key to ON and wait until the glow indicator light  goes out.

2. Crank the engine by turning the ignition key to START. Release the key when the engine starts.

**If it is difficult to restart the engine immediately after it has been stopped because of high fuel temperature, lightly depress the accelerator pedal.**

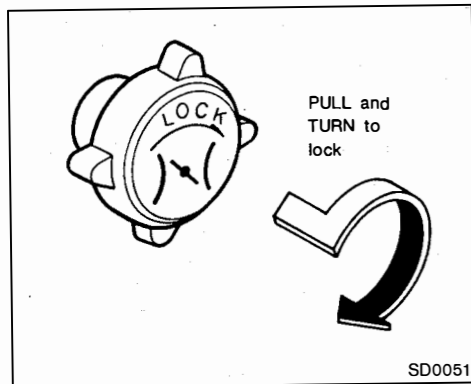

SD0051

### Throttle control knob

#### Alternative use:

The engine can be maintained at the desired speed without depressing the accelerator pedal.

Pull the knob and/or rotate it clockwise to hold it at the desired position.

**Avoid driving the vehicle with the throttle control knob pulled out.**

## DRIVING VEHICLE

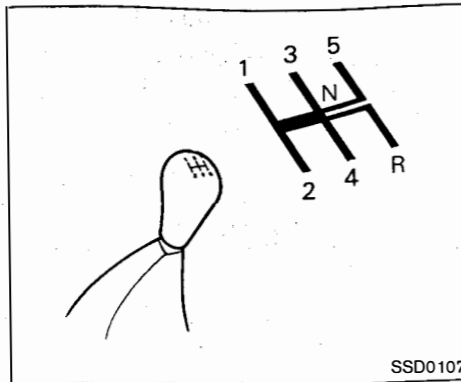

SSD01051

### DRIVING WITH MANUAL TRANSMISSION

#### Starting the vehicle

1. Depress the clutch pedal to the floor and move the shift lever to the "1" or "R" position.
2. Slowly depress the accelerator pedal, releasing the clutch pedal and parking brake at the same time.

#### Shifting

To change gears, or when up shifting or down shifting, depress the clutch pedal fully, shift into the appropriate gear, then release the clutch slowly and smoothly.

You cannot shift directly from 5th gear into R. First shift to N, then into R.

If it is difficult to move the shift lever into R or shift to N, then release the clutch pedal. Fully depress the clutch pedal again and shift into R or 1.

#### CAUTION:

- Do not rest your foot on the clutch pedal while driving. This may cause clutch damage.
- Stop your vehicle completely before shifting into R.
- When you are shifting from one gear to another, be certain to press the clutch pedal all the way to the floor to avoid clashing or chipping the gears.
- Avoid abrupt starts and acceleration for your safety.

When quick acceleration is required for some reason, shift to a lower gear and accelerate until the vehicle reaches the maximum speed in each gear. Do not exceed the speed limit of any gear. Pay special attention when accelerating or when shifting into a lower gear on slippery surfaces. Sudden acceleration or down shifting could cause the wheels to skid and result in loss of control.

### DRIVING WITH AUTOMATIC TRANSMISSION (5-speed models)

#### Starting the vehicle

After starting the engine, fully depress the foot brake pedal before shifting the selector lever to the R (Reverse), D (Drive) or Manual shift mode position. Be sure the vehicle is fully stopped before attempting to shift the selector lever.

The automatic transmission is designed so that the foot brake pedal **MUST** be depressed before shifting from P (Park) to any drive position while the ignition switch is ON.

1. Keep the foot brake pedal depressed and shift into a driving gear.
2. Release the parking brake and foot brake, then start the vehicle in motion.

#### CAUTION:

- Cold engine idle speed is high, so use caution when shifting into a forward or reverse gear before the engine has warmed up.
- Avoid revving up the engine while the vehicle is stopped. This could cause unexpected vehicle movement.

#### Driving precautions

- Never shift to P (Park) or R (Reverse) while the vehicle is moving.
- Start the engine in the P (Park) or N (Neutral) position. It will not start in any other selector position. If it does, have your vehicle checked by a NISSAN dealer.
- Shift into N (Neutral) position and apply the parking brake when at a standstill for longer than a short waiting period.
- Keep the engine at idling speed while shifting from N (Neutral) to any driving position.
- When stopped on an upgrade. Use your brakes (selector lever in the N position) to hold the vehicle in place to prevent overheating the transmission.

#### CAUTION: (When starting vehicle)

- **DEPRESS THE FOOT BRAKE PEDAL.** Shifting the selector lever to R (Reverse), D (Drive) or Manual shift mode position without depressing the brake pedal causes the vehicle to move slowly when the engine is running. Be sure the brake pedal is depressed fully and the

vehicle is stopped before shifting the selector lever.

- **MAKE SURE OF THE SELECTOR LEVER POSITION.**

Make sure the selector lever is in the desired position. D (Drive), Manual shift mode are used to move forward and R (Reverse) to back-up. Then release the parking brake and foot brake pedal. Depress the accelerator pedal to start the vehicle and merge with traffic. (Avoid abrupt starting and spinning the tires.) Avoid revving up the engine while the vehicle is stopped. (This could cause unexpected vehicle movement if the selector lever were in R, D, Manual shift mode position or damage the engine if in N or P.)

- **WARM THE ENGINE UP.**

Due to the higher idle speeds when the engine is cold, extra caution must be exercised when shifting the selector lever into the driving position immediately after starting the engine.

- **PARKING THE VEHICLE.**

Depress the foot brake pedal and, once the vehicle stops, move the selector lever into the P (Park) position, apply

the parking brake and release the foot brake pedal.

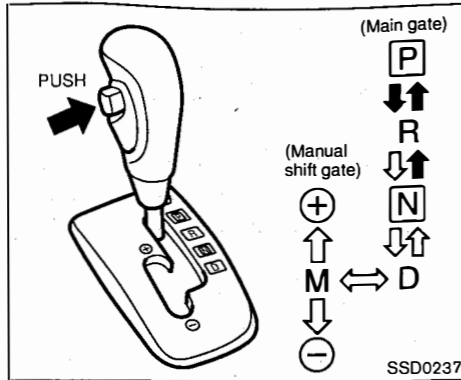

### Shifting

Push the button to shift into P or R. All other positions can be selected without pushing the button.

#### P (Park):

Use this position when the vehicle is parked or when starting the engine. Use this position together with the parking brake. When parking on a hill, first depress the foot brake pedal, apply the parking brake and then shift into the P position.

#### CAUTION:

**Use this position only when the vehicle is completely stopped.**

#### R (Reverse):

Use this position to back up. Shift into this position only after the vehicle has completely stopped.

#### N (Neutral):

Neither forward nor reverse gear is engaged. The engine can be started in this position. You may shift to N and restart a stalled engine while the vehicle is moving.

#### D (Drive):

Use this position for all normal forward driving.

#### Manual shift mode

When the selector lever is shifted from D to the manual shift gate with the vehicle stopped or while driving, the transmission enters the manual shift mode. Shift range can be selected manually.

In the manual shift mode, the shift range is displayed on the position indicator in the tachometer. When shifting the selector lever to the manual shift gate, the indicator first displays 4<sup>M</sup> (4th).

Shift ranges up or down one by one as follows:

1st → 2nd → 3rd → 4th → 5th  
 ← ← ← ← ←

- When shifting up, move the selector lever to the + (up) side. (Shifts to higher range.)

- When shifting down, move the selector lever to the - (down) side. (Shifts to lower range.)
- The transmission will automatically shift the gears between the 1st and the selected range. (For example, if you select the 3rd range, the transmission will shift up or down between the 1st and the 3rd gears.)
- Moving the selector lever rapidly to the same side twice will shift the ranges in succession.
- When canceling the manual shift mode, return the selector lever to the D position. The transmission returns to the normal driving mode.

- In the manual shift mode, the transmission may not shift to the selected gear. This helps maintain driving performance and reduces the chance of vehicle damage or loss of control.**
- In the manual shift mode, the transmission may shift up automatically over the selected range if the engine is revving up to the hazardous speed. When the vehicle speed decreases, the transmission automatically shifts down and shifts to 1st gear before the vehicle comes to a stop.**

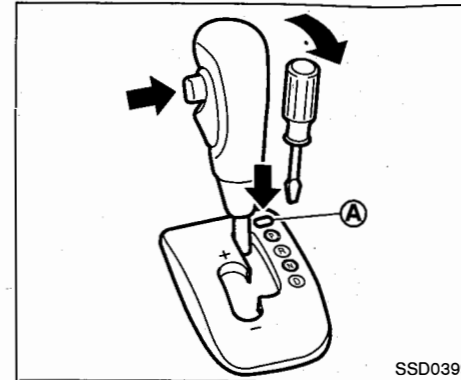

#### Shift lock release

If the battery charge is low, the selector lever may not be moved from the P (Park) position even with the brake pedal depressed and the selector lever button pushed.

To move the selector lever, push the shift lock release button (A) and selector lever button while the ignition switch is in the ACC position. Use a suitable tool to push the shift lock release button. The selector lever can be moved to N (Neutral).

If the lever cannot be moved out of P, have a NISSAN dealer check the automatic transmission system as soon as possible.

#### ! WARNING:

**If the selector lever cannot be moved from the P position while the engine is running and the brake pedal is depressed, the stop lights may not work. Malfunctioning stop lights could cause an accident injuring yourself and others.**

Accelerator downshift  
 — In D position —

For rapid passing or hill climbing, fully depress the accelerator pedal to the floor. This shifts the transmission down into the lower gear, depending on the vehicle speed.

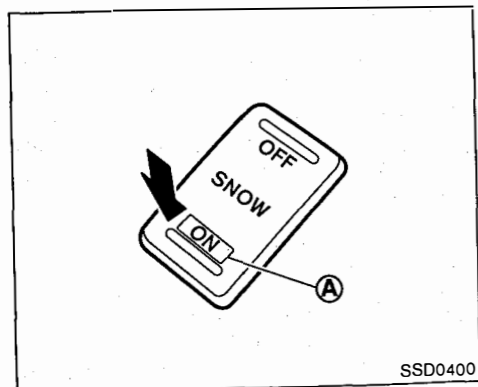

#### Automatic transmission mode switch (if so equipped)

To turn on the switch, push the lower side of it. The indicator light of the switch (A) will illuminate and the transmission shifts into the SNOW driving mode.

- This mode is used for standing starts on slippery (snowy, sandy) roads.
- When the selector lever is in the D position, the transmission shifts from 1st to 5th gear automatically from standing starts or when accelerating from low speed.

#### Fail-safe

When the fail-safe operation occurs, the auto-

matic transmission will be locked in 4th gear.

If the vehicle is driven under extreme conditions, such as excessive wheel spinning and subsequent hard braking, the fail-safe system may be activated. This will occur even if all electrical circuits are functioning properly. In this case, turn the ignition switch off and wait for 3 seconds. Then turn the ignition switch back to the ON position. The vehicle should return to its normal operating condition. If it does not return to its normal operating condition, have a NISSAN dealer check the transmission and repair it if necessary.

### DRIVING WITH AUTOMATIC TRANSMISSION (4-speed models)

#### Starting the vehicle

After starting the engine, fully depress the foot brake pedal before shifting the selector lever to the D, R, 2 or 1 position. Be sure the vehicle is fully stopped before attempting to shift the selector lever.

The automatic transmission is designed so that the foot brake pedal **MUST** be depressed before shifting from P (Park) to any drive position while the ignition switch is ON.

1. Keep the foot brake pedal depressed and shift into a driving gear.
2. Release the parking brake and foot brake, then start the vehicle gradually.

#### CAUTION:

- Cold engine idle speed is high, so use caution when shifting into a forward or reverse gear before the engine has warmed up.
- Avoid racing the engine while the vehicle is stopped. This could cause unexpected vehicle movement.

#### Driving precautions

- Never shift to P or R while the vehicle is moving.
- Start the engine in the P or N position. It will not start in any other selector position. If it does, have your vehicle checked by a NISSAN dealer.
- Shift into N position and apply the parking brake when at a standstill for longer than a short waiting period.
- Keep the engine at idling speed while shifting from N to any driving position.
- When stopped on an upgrade. Use your brakes (selector lever in the N position) to hold the vehicle in place to prevent overheating the transmission.

#### CAUTION: (When starting vehicle)

- DEPRESS THE FOOT BRAKE PEDAL.  
Shifting the selector lever to D, R, 2 or 1 without depressing the brake pedal causes the vehicle to move slowly when the engine is running. Be sure the brake pedal is depressed fully and the vehicle is stopped before shifting the selector lever.

- MAKE SURE OF THE SELECTOR LEVER POSITION.

Make sure the selector lever is in the desired position. D, 1, 2 are used to move forward and R to back-up. Then release the parking brake and foot brake pedal. Depress the accelerator pedal to start the vehicle and merge with traffic. (Avoid abrupt starting and spinning the tires.) Avoid revving up the engine while the vehicle is stopped. (This could cause unexpected vehicle movement if the selector lever were in D, R, 2 or 1 or damage the engine if in N or P.)

- WARM THE ENGINE UP.

Due to the higher idle speeds when the engine is cold, extra caution must be exercised when shifting the selector lever into the driving position immediately after starting the engine.

- PARKING THE VEHICLE.

Depress the foot brake pedal and, once the vehicle stops, move the selector lever into P, apply the parking brake and release the foot brake pedal.

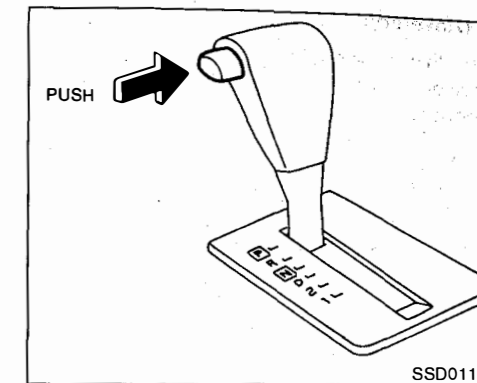

#### Shifting

Push the button to shift into P, R or from 2 to 1. All other positions can be selected without pushing the button.

#### P (Park):

Use this position when the vehicle is parked or when starting the engine. Use this position together with the parking brake. When parking on a hill, first depress the foot brake pedal, apply the parking brake and then shift into the P position.

#### CAUTION:

Use this position only when the vehicle is completely stopped.

### R (Reverse):

Use this position to back up. Shift into this position only after the vehicle has completely stopped.

### N (Neutral):

Neither forward nor reverse gear is engaged. The engine can be started in this position. You may shift to N and restart a stalled engine while the vehicle is moving.

### D (Drive):

Use this position for all normal forward driving.

### 2 (Second gear):

Use for hill climbing, effective engine braking on downhill grades or starting on slippery roads.

Do not downshift into the 2 position at speeds over 76 km/h (47 MPH). Do not exceed 76 km/h (47 MPH) in the 2 position.

### 1 (Low gear):

Use this position when climbing steep hills slowly or driving slowly through deep snow, sand or mud, or for maximum engine braking on steep downhill grades.

Do not shift into the 1 position at speeds over 38 km/h (24 MPH). Do not exceed 38 km/h (24 MPH) in the 1 position.

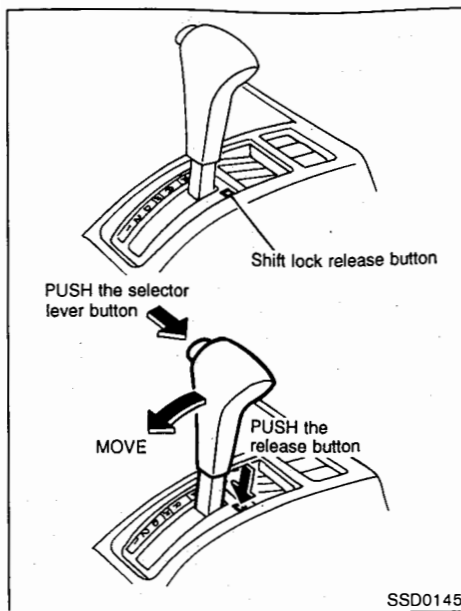

### Shift lock release

If the battery charge is low, the selector lever may not be moved from the P position even with the brake pedal depressed and the selector lever button pushed.

To move the selector lever, push the shift lock release button and selector lever button while

the ignition switch is in the ACC position. The selector lever can be moved to N (Neutral).

To push the shift lock release button, follow the procedure as illustrated.

If the selector lever cannot be moved out of P (Park), have a NISSAN dealer check the automatic transmission system as soon as possible.

### WARNING:

**If the selector lever cannot be moved from the P position while the engine is running and the brake pedal is depressed, the stop lights may not work. Malfunctioning stop lights could cause an accident injuring yourself and others.**

### Accelerator downshift — In "D" position —

For rapid passing or hill climbing, fully depress the accelerator pedal to the floor. This shifts the transmission down into second gear or first gear, depending on the vehicle speed.

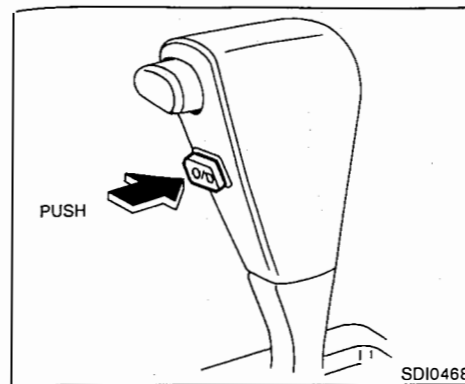

### Overdrive switch

ON: For normal driving, push the overdrive switch "ON  " with the selector lever in the "D" position. The transmission is upshifted into OVERDRIVE as the vehicle speed increases.

**The overdrive will not engage until the engine has warmed up.**

OFF: For driving up and down long slopes where engine "braking" would be advantageous, push the switch to the "OFF  " position. When cruising at a low speed or climbing a gentle slope, you may feel uncomfortable shift shocks as the transmission shifts between 3rd

and overdrive repeatedly. In this case, set the overdrive switch in the "OFF  " position. The O/D OFF indicator light will come on at this time.

When driving conditions change, reset the overdrive switch to the "ON  " position.

Remember not to drive at high speeds for extended periods of time with the overdrive switch set in the "OFF  " position. This reduces the fuel economy.

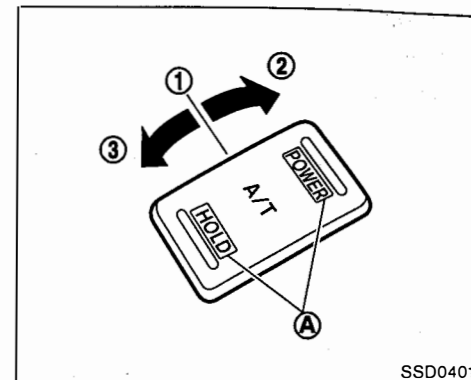

### Automatic transmission mode switch (if so equipped)

Three different driving pattern modes are available on this automatic transmission, ① AUTO, ② POWER and ③ HOLD. (A) : Indicator light. Each mode is designed to maximize driving performance under different driving conditions. These modes can be selected by pushing the mode switch (located on the center console) to the appropriate position, as shown above. For normal driving, use ① AUTO position.

### AUTO MODE:

This mode is used for economical driving:

- Automatically selects ECONOMY or

POWER pattern in response to accelerator pedal depression speed.

- Upshifts from 1st to 4th gear (or 3rd gear when OD switch is OFF) occur automatically.

#### POWER MODE:

This mode is used for rapid acceleration or uphill driving:

- Holds POWER pattern; the shifting speeds in each gear change to ones somewhat higher mode than those of the AUTO mode.
- Upshifts from 1st to 4th gear (or 3rd gear when OD switch is OFF) occur automatically.

#### HOLD MODE:

This mode is used for standing starts on slippery (snowy, sandy) roads:

- When the selector lever is in the D position, the transmission shifts from 2nd to 3rd gear (and 4th gear when OD switch is ON) automatically from standing starts or when accelerating from low speed. The transmission will not use the 1st gear, which will improve driveability in slippery conditions.
- When the selector lever is in the 2 position, 2nd gear is held.

#### Fail-safe

When the fail-safe operation occurs, the auto-

matic transmission will be locked in third gear.

**If the vehicle is driven under extreme conditions, such as excessive wheel spinning and subsequent hard braking, the fail-safe system may be activated. This will occur even if all electrical circuits are functioning properly. In this case, turn the ignition switch off and wait for 3 seconds. Then turn the ignition switch back to the ON position. The vehicle should return to its normal operating condition. If it does not return to its normal operating condition, have a NISSAN dealer check the transmission and repair it if necessary.**

### 4x4 FOUR-WHEEL DRIVE (4WD)

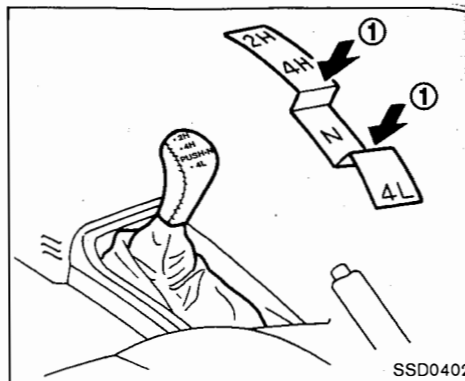

#### TRANSFER CASE SHIFTING PROCEDURES

When shifting from "4H" to "4L", or "4L" to "4H", depress ① the transfer shift lever.

The four-wheel drive (4WD) mode indicator light will come on when the "4H" or "4L" position is selected.

**2H** — (2WD, high range) Only the rear wheels are driven. Use when driving under the same conditions as standard 2WD vehicle.

**4H** — (4WD, high range) Four wheels are driven. Use when driving on roads where it is difficult to drive in the 2H position (for example, driving at

normal speeds on snow covered, muddy or sandy roads).

**4L** — (4WD, low range) Four wheels are driven. Use when climbing or descending steep hills, or during driving in sand, mud or deep snow. The "4L" position provides maximum power and traction. Avoid raising vehicle speed excessively, as the maximum speed in 5th gear is approximately 50 km/h (30 MPH).

**N (or between "4H" and "4L")** — No wheels are driven. Always keep the transfer shift lever out of the "N" (Neutral; between "4H" and "4L") position. Shift the lever quickly and smoothly when moving across the "N" position with the vehicle stopped.

#### CAUTION:

**Do not drive on dry hard surface roads in 4WD.**

**Driving on dry hard surfaces in "4H" or "4L" may cause unnecessary noise and tire wear. NISSAN recommends driving in the "2H" position under these conditions.**

#### ⚠ WARNING:

- When parking the vehicle, apply the parking brake and shift the transfer shift lever in the "2H", "4H" or "4L" position.
- Do not leave the transfer shift lever in

the "N" position. Otherwise, the vehicle could roll unexpectedly even if the manual transmission is in any gear or the automatic transmission in the "P" position.

Models without free-running hubs

TO SHIFT TRANSFER CASE:	SHIFT PROCEDURE FOR MODELS WITHOUT FREE-RUNNING HUBS
From "2H" to "4H"	Move the transfer shift lever to "4H". It is not necessary to depress the clutch pedal. Perform this operation when driving straight.
From "4H" to "2H"	Move the transfer shift lever to "2H". This can be done at any speed and it is not necessary to depress the clutch pedal. Perform this operation when driving straight.
From "4H" or "4L" to "4L" or "4H"	<ol style="list-style-type: none"> <li>1. Stop the vehicle.</li> <li>2. Depress the clutch pedal.</li> <li>3. Depress the transfer shift lever and move it to the desired "4L" or "4H" position.</li> </ol>
From "2H" to "4L"	<ol style="list-style-type: none"> <li>1. Stop the vehicle.</li> <li>2. Depress the clutch pedal.</li> <li>3. Depress the transfer shift lever and move it to "4L". Change gears quickly and smoothly.</li> </ol>
From "4L" to "2H"	<ol style="list-style-type: none"> <li>1. Stop the vehicle.</li> <li>2. Depress the clutch pedal.</li> <li>3. Depress the transfer shift lever and move it to "2H".</li> </ol>

For models with free-running hubs, see "Two-way lock free-running hubs" or "Manual-lock free-running hubs" later in this section.

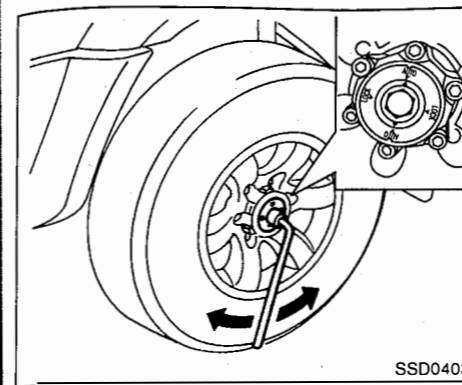

**TWO-WAY LOCK FREE-RUNNING HUBS (if so equipped)**

The two-way lock free-running hub (on the front wheels) is designed to allow you to select the "LOCK" or "AUTO" position. Before driving, set the free-running hubs to the desired position by turning the center bolts on the hubs with the wheel wrench.

Be sure to align the "inner ▲" mark with the "outer ▼" mark on the wheel hub.

The free-running hubs will make a clicking noise when engaging and disengaging. This is normal.

**CAUTION:**

**Do not drive your vehicle with the left and**

**right free-running hubs set to different positions.**

**LOCK position**

In this position, the front drive shafts are always engaged with the front wheels.

**AUTO position**

This position allows for automatic four-wheel drive engagement when the transfer shift lever is moved to the "4H" or "4L" position. Follow these operational cautions:

**CAUTION:**

- Accelerating the vehicle suddenly from a stop with the transfer shift lever in the "4H" or "4L" position may not engage the free-running hubs and may cause a clattering noise. If this occurs, release the accelerator pedal to reduce the engine speed. Continued use of the vehicle with this noise may damage the hub lock.
- If the free-running hubs make a clattering noise while driving with the transfer shift lever in the "2H" position, stop and move the vehicle about 2 to 3 meters (7 to 10 ft) in the opposite direction of travel.
- Under extremely cold conditions [below

-15°C (5°F)], when the vehicle is driven in 2WD at high speeds without first warming up the vehicle and gear oil, the axle shafts may rotate. This will cause the hubs to make a clattering noise. To avoid this, first drive in 4WD to warm up the vehicle and gear oil, and then shift to 2WD.

- When shifting from the "2H" to "4H" position while driving, do not stop the transfer shift lever movement midway. An incomplete shift or disengagement of only one hub lock may cause a clattering noise from the free-running hubs. Continued use of the vehicle with this noise may damage the hub lock. Shift to 4WD to stop the noise; unlock hubs as described.
- In cold weather, it may be necessary to reduce speed or stop the vehicle to shift from the "2H" to "4H" position.



TO SHIFT TRANSFER CASE:	SHIFT PROCEDURE FOR TWO-WAY LOCK FREE-RUNNING HUBS IN "AUTO" POSITION
From "2H" to "4H"	Move the transfer shift lever to "4H" at speeds below 40 km/h (25 MPH). It is not necessary to depress the clutch pedal. Perform this operation when driving straight.
From "4H" to "2H"	Move the transfer shift lever to "2H". This can be done at any speed up to 80 km/h (50 MPH) and it is not necessary to depress the clutch pedal (manual transmission models). Perform this operation when driving straight. <b>NOTE:</b> For 2WD operation, set the free-running hubs in the disengaged position. TWO-WAY LOCK hubs will not disengage until the vehicle is moved about 1 m (3 ft) in the opposite direction of travel: <ul style="list-style-type: none"> <li>• When driving forward, stop and move 1 m (3 ft) in reverse.</li> <li>• When backing up, stop and move 1 m (3 ft) forward, then move the vehicle about 1 m (3 ft) in reverse.</li> </ul> This will allow for better fuel economy, quieter ride and less component wear.
From "4H" or "4L" to "4L" or "4H"	<ol style="list-style-type: none"> <li>1. Stop the vehicle.</li> <li>2. Depress the clutch pedal (On automatic transmission models, place the selector lever in the "N" position).</li> <li>3. Depress the transfer shift lever and move it to the desired "4L" or "4H" position.</li> </ol> <b>NOTE:</b> On automatic transmission models, do not leave the transfer shift lever between the "4H" and "4L" positions. Stopping in this position may cause gear grinding when selecting another gear. Changing transfer case gear quickly and smoothly will eliminate this. If the transfer case is left in "N" for more than a few seconds and you have difficulty selecting another gear, turn off the engine, make the gear selection and restart the engine. <b>CAUTION:</b> With the engine running, do not place the transfer case in "N" and attempt to select "P" in the transmission.
From "2H" to "4L"	<ol style="list-style-type: none"> <li>1. Stop the vehicle.</li> <li>2. Depress the clutch pedal (On automatic transmission models, move the transmission selector lever to the "N" position).</li> <li>3. Depress the transfer shift lever and move it to "4L". Change gears quickly and smoothly.</li> </ol> <b>NOTE:</b> On automatic transmission models, sometimes, with the vehicle stopped, the transfer shift lever will not move directly from "2H" to "4L". When this occurs, follow the "NOTE" shown in shifting from "4H" or "4L" to "4L" or "4H".
From "4L" to "2H"	<ol style="list-style-type: none"> <li>1. Stop the vehicle.</li> <li>2. Depress the clutch pedal (On automatic transmission models, move the transmission selector lever to the "N" position).</li> <li>3. Depress the transfer shift lever and move it to "2H".</li> </ol> <b>NOTE:</b> Follow the "NOTE" shown in shifting from "4H" to "2H".

TO SHIFT TRANSFER CASE:	SHIFT PROCEDURE FOR TWO-WAY LOCK FREE-RUNNING HUBS IN "LOCK" POSITION
From "2H" to "4H"	Move the transfer shift lever to "4H". This can be done at any speed up to 80 km/h (50 MPH) and it is not necessary to depress the clutch pedal. Perform this operation when driving straight.
From "4H" to "2H"	Move the transfer shift lever to "2H". This can be done at any speed up to 80 km/h (50 MPH) and it is not necessary to depress the clutch pedal (manual transmission models). Perform this operation when driving straight. <b>NOTE:</b> For 2WD operation, set the free-running hubs in the AUTO position and move vehicle about 1 m (3 ft) in the opposite direction of travel for disengagement: <ul style="list-style-type: none"> <li>• When driving forward, stop and move 1 m (3 ft) in reverse.</li> <li>• When backing up, stop and move 1 m (3 ft) forward, then move the vehicle about 1 m (3 ft) in reverse.</li> </ul> This will allow for better fuel economy, quieter ride and less component wear.
From "4H" or "4L" to "4L" or "4H"	<ol style="list-style-type: none"> <li>1. Stop the vehicle.</li> <li>2. Depress the clutch pedal (On automatic transmission models, put the selector lever in the "N" position).</li> <li>3. Depress the transfer shift lever and move it to the desired "4L" or "4H" position.</li> </ol> <b>NOTE:</b> On automatic transmission models, do not leave the transfer shift lever between the "4H" and "4L" positions. Stopping in this position may cause gear grinding when selecting another gear. Changing transfer case gear quickly and smoothly will eliminate this. If the transfer case is left in "N" for more than a few seconds and you have difficulty selecting another gear, turn off the engine, make the gear selection and restart the engine. <b>CAUTION:</b> With the engine running, do not place the transfer case in "N" and attempt to select "P" in the transmission.
From "2H" to "4L"	<ol style="list-style-type: none"> <li>1. Stop the vehicle.</li> <li>2. Depress the clutch pedal (On automatic transmission models, move the transmission selector lever to the "N" position).</li> <li>3. Depress the transfer shift lever and move it to "4L". Change gears quickly and smoothly.</li> </ol> <b>NOTE:</b> On automatic transmission models, sometimes, with the vehicle stopped, the transfer shift lever will not move directly from "2H" to "4L". When this occurs follow the "NOTE" shown in shifting from "4H" or "4L" to "4L" or "4H".
From "4L" to "2H"	<ol style="list-style-type: none"> <li>1. Stop the vehicle.</li> <li>2. Depress the clutch pedal (On automatic transmission models, move the transmission selector lever to the "N" position).</li> <li>3. Depress the transfer shift lever and move it to "2H".</li> </ol> <b>NOTE:</b> Follow the "NOTE" shown in shifting from "4H" to "2H".

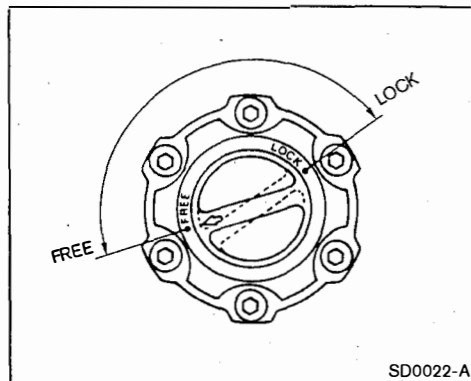

### MANUAL-LOCK FREE-RUNNING HUBS (if so equipped)

The manual-lock free-running hub (on the front wheels) is designed to allow you to engage or disengage the front drive shaft to the front wheels. Before driving, set the free-running hub to the desired position:

- For 2WD operation — Turn the knob to the FREE position.
- For 4WD operation — Turn the knob to the LOCK position.

Be sure to align the "◁" mark on the knob with the "●" mark on the wheel hub.

### CAUTION:

- Never drive in 4WD ("4H" or "4L" position) with the free-running hubs in the FREE position.
- Do not drive your vehicle with the left and right free-running hubs set to different positions.
- For the first 500 km (300 miles) it is recommended that you drive in 2WD ("2H" position), with the free-running hubs set in the LOCK position.
- To ensure proper lubrication of front drive components, drive in the LOCK position for at least 16 km (10 miles) each month.

TO SHIFT TRANSFER CASE:	SHIFT PROCEDURE FOR MANUAL-LOCK FREE-RUNNING HUBS
From "2H" to "4H"	<ol style="list-style-type: none"> <li>1. Stop the vehicle.</li> <li>2. Set free-running hubs in the LOCK position.</li> <li>3. Move the transfer shift lever to "4H". This can be done at any speed up to 80 km/h (50 MPH) and it is not necessary to depress the clutch pedal. Perform this operation when driving straight.</li> </ol>
From "4H" to "2H"	<p>Move the transfer shift lever to "2H". This can be done at any speed up to 80 km/h (50 MPH) and it is not necessary to depress the clutch pedal (manual transmission models). Perform this operation when driving straight.</p> <p><b>NOTE:</b> For 2WD operation, set the free-running hubs in the FREE position. This will allow for better fuel economy, quieter ride and less component wear.</p>
From "4H" or "4L" to "4L" or "4H"	<ol style="list-style-type: none"> <li>1. Stop the vehicle.</li> <li>2. Depress the clutch pedal (On automatic transmission models, put the selector lever in the "N" position).</li> <li>3. Depress the transfer shift lever and move it to the desired "4L" or "4H" position.</li> </ol> <p><b>NOTE:</b> On automatic transmission models, do not leave the transfer shift lever between the "4H" and "4L" positions. Stopping in this position may cause gear grinding when selecting another gear. Changing transfer case gear quickly and smoothly will eliminate this. If the transfer case is left in "N" for more than a few seconds and you have difficulty selecting another gear, turn off the engine, make the gear selection and restart the engine.</p> <p><b>CAUTION:</b> With the engine running, do not place the transfer case in "N" and attempt to select "P" in the transmission.</p>
From "2H" to "4L"	<ol style="list-style-type: none"> <li>1. Stop the vehicle.</li> <li>2. Set free-running hubs in the LOCK position.</li> <li>3. Depress the clutch pedal (On automatic transmission models, move the transmission selector lever to the "N" position).</li> <li>4. Depress the transfer shift lever and move it to "4L". Change gears quickly and smoothly.</li> </ol> <p><b>NOTE:</b> On automatic transmission models, sometimes, with the vehicle stopped, the transfer shift lever will not move directly from "2H" to "4L". When this occurs follow the "NOTE" shown in shifting from "4H" or "4L" to "4L" or "4H".</p>
From "4L" to "2H"	<ol style="list-style-type: none"> <li>1. Stop the vehicle.</li> <li>2. Depress the clutch pedal (On automatic transmission models, move the transmission selector lever to the "N" position).</li> <li>3. Depress the transfer shift lever and move it to "2H".</li> </ol> <p><b>NOTE:</b> Follow the "NOTE" shown in shifting from "4H" to "2H".</p>

## **4x4** DRIVING FOUR-WHEEL DRIVE (4WD) SAFELY

Your vehicle is designed for both normal and off-road use. It has a higher ground clearance and a narrower track to make it suitable for off-road use. These characteristics give the vehicle a higher center of gravity than ordinary passenger cars. An advantage of the higher ground clearance is a better view of your surroundings allowing you to anticipate problems. Observe the following precautions:

- Drive carefully when off the road and avoid dangerous areas.
- **Do not drive across steep slopes. Instead drive either straight up or straight down the slopes. Off-road vehicles can tip over sideways much more easily than they can forward or backward.**
- **Do not drive beyond the performance of the tires even with 4WD. Sudden acceleration, steering or braking may cause loss of control or the vehicle to stick in the road.**
- If at all possible, avoid sharp turning maneuvers, particularly at high speeds. Your 4WD vehicle has a higher center of gravity than a 2WD vehicle and can tip over more easily. The vehicle is not designed for cornering at

the same speeds as conventional 2WD vehicles any more than low-slung sports cars are designed to perform satisfactorily under off-road conditions. Failure to operate this vehicle correctly could result in loss of control and/or a rollover accident.

- Avoid raising the center of gravity by loading things on the roof or equipping the vehicle with tires larger than specified in this manual.
- Do not grip the inside or spokes of the steering wheel when driving off-road. The steering wheel could jerk and injure your hands. Instead drive with your fingers and thumbs on the outside of the rim.
- Before operating the vehicle, ensure that the driver and all passengers have their seat belts fastened.
- Always drive with the floor mats in place as the floor may become very hot. Particular care should be taken if you are barefoot.
- Lower your speed when encountering strong crosswinds. With its higher center of gravity, your NISSAN is more affected by gusty side winds. Slower speeds ensure better vehicle control.
- Be sure to check the brakes immediately after driving in mud or water. To dry the wet

brakes, see "Brake system" later in this section.

- Whenever you drive off-road through sand or mud or water as deep as the wheel hub, more frequent maintenance may be required. For details, refer to "Maintenance for off-road driving" in a separate maintenance booklet.
- Rinse the underside of the vehicle with fresh water after driving through mud or sand. Remove any brush or sticks that are trapped.
- Install the same size of winter tires on all four (4) wheels (such as studless tires) or install tire chains to the rear wheels when driving on slippery roads (e.g., after a snow) and drive carefully using 4WD.

## **4x4** TIRES OF FOUR-WHEEL DRIVE (4WD)

### CAUTION:

**Always use tires of the same size, brand, construction (bias, bias-belted or radial), and tread pattern on all four wheels. Failure to do so may result in a circumference difference between tires on the front and rear axles which will cause excessive tire wear and may damage the transmission, transfer case and differential gears.**

If excessive tire wear is found, it is recommended that all four tires be replaced with tires of the same size, brand, construction and tread pattern. The tire pressure and wheel alignment should also be checked and corrected as necessary. Contact a NISSAN dealer.

### Snow tires

If you install snow tires, they must also be the same size, brand, construction and tread pattern on all four wheels.

### CAUTION:

**ONLY use spare tires specified for each 4WD model.**

### Tire inflation pressure

Check the pressures in all tires, including the

spare, with a gauge periodically when at a service station. Adjust to the specified pressure if necessary. Tire pressures are shown on the tire placard affixed to the glove box or driver side center pillar.

### Tire rotation

NISSAN recommends that tires be rotated every 5,000 km (3,000 miles). Do not include the temporary spare tire in the tire rotation.

### Tire chain

**Tire chains must be installed only on the rear wheels and not on the front wheels.**

Do not drive with tire chains on paved roads which are clear of snow. Driving with chains in such conditions can cause damage to the various mechanisms of the vehicle due to over-stress. When driving on clear paved roads, be sure to change to 2WD.

## CRUISE CONTROL (if so equipped)



### WARNING:

**Do not use the cruise control when driving under the following conditions:**

- when it is not possible to keep the vehicle at set speed.
- in heavy traffic or in traffic that varies in speed.
- on winding or hilly roads.
- on slippery roads (rain, snow, ice, etc.)
- in very windy areas.

**Doing so could cause a loss of vehicle control and result in an accident.**

### CAUTION:

**On the manual transmission model, do not shift into N (Neutral) position without depressing the clutch pedal when the cruise control is on. This could cause engine damage. If you shift into neutral without depressing the pedal, depress the clutch pedal and turn the main switch off immediately.**

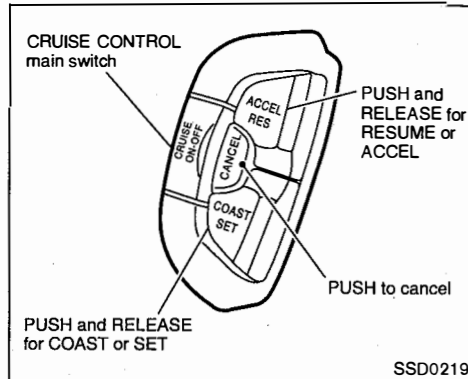

## CRUISE CONTROL OPERATIONS

The cruise control allows driving at speeds above 48 km/h (30 MPH) without your foot on the accelerator pedal.

**To turn on the cruise control**, push the main switch on. The cruise control on indicator light CRUISE will come on.

**To set at the cruising speed**, accelerate your vehicle to the desired speed, push the COAST/SET switch and release it. (The cruise set indicator light **SET** will come on.) Take your foot off the accelerator pedal. Your vehicle will maintain the set speed.

- **To pass another vehicle**, depress the ac-

celerator pedal. When you release the pedal, the vehicle will return to the previously set speed.

- The vehicle may not maintain the set speed when going up or down steep hills. If this happens, drive without the cruise control.

**To cancel the preset speed**, follow any of these three methods:

- Push the CANCEL switch; The SET indicator light will go out.
- Tap the brake pedal; The SET indicator light will go out.
- Turn the main switch off. Both the CRUISE and SET indicator lights will go out.

- If you depress the brake pedal while pushing the ACCEL/RES or COAST/SET switch and reset at the cruising speed, the cruise control will disengage. Turn the main switch off once and then turn it on again.

- The cruise control will automatically be cancelled if the vehicle slows down below approximately 13 km/h (8 MPH).

- Depress the clutch pedal (manual transmission), or move the selector lever to N position (automatic transmission). The SET indicator light will go out.

**To reset at a faster cruising speed**, follow

either of these three methods:

- Depress the accelerator pedal. When the vehicle attains the desired speed, push and release the COAST/SET switch.
- Push and hold the ACCEL/RES set switch. When the vehicle attains the speed you desire, release the switch.
- Push, then quickly release the ACCEL/RES set switch. Each time you do this, the set speed will increase by about 1.6 km/h (1 MPH).

**To reset at a slower cruising speed**, follow either of these three methods:

- Lightly tap the brake pedal. When the vehicle attains the desired speed, push the COAST/SET switch and release it.
- Push and hold the COAST/SET switch. Release the switch when the vehicle slows down to the desired speed.
- Push, then quickly release the COAST/SET switch. Each time you do this, the set speed will decrease by about 1.6 km/h (1 MPH).

**To resume the preset speed**, push and release the ACCEL/RES set switch. The vehicle will resume the last set cruising speed when the vehicle speed is over 48 km/h (30 MPH).

## PRECAUTIONS ON CRUISE CONTROL

- If the cruise control system malfunctions, it will cancel automatically. The SET indicator light will then blink to warn the driver.
- When the SET indicator light blinks, turn the cruise control main switch OFF and have the system checked by a NISSAN dealer.
- The SET indicator light may blink when the cruise control main switch is turned on while pushing the ACCEL/RES, COAST/SET, or CANCEL switch. To properly set the cruise control system, perform the preceding steps in the order indicated.

## PARKING

### ⚠ WARNING:

- **Do not stop or park the vehicle over flammable materials, such as dry grass, waste paper, or rags. They may ignite and cause a fire.**
-  The transfer shift lever must be in the 2H, 4H or 4L position and the parking brake must be applied to prevent the vehicle from rolling.
- **Never place the transfer shift lever in the N (Neutral) position, otherwise, the vehicle could roll unexpectedly even if the manual transmission is in gear or the automatic transmission is in the P (Park) position. This could result in serious personal injury or property damage.**
- **Never leave the engine running while vehicle is unattended.**
- **Never leave children unattended in the vehicle.**

1. Firmly apply the parking brake.

### 2. Manual transmission models:

Place the shift lever in the R (Reverse) position. When parking on an uphill grade, place the gearshift lever in the 1st position.

### Automatic transmission models:

Move the selector lever to the P (Park) position.

### ⚠ WARNING:

- **Safe parking procedures require that both the parking brake be set and the transmission placed into the P (Park) for automatic transmission models or in an appropriate gear for manual transmission models. Failure to do so could cause the vehicle to move unexpectedly or roll away and result in an accident.**
- **Make sure the automatic transmission selector lever has been pushed as far forward as it can go and cannot be moved without depressing the foot brake pedal.**
- **If the automatic transmission park warning light "ATP" is ON, this indicates that the automatic transmission P (Park) position will not function and the transfer shift lever is in the N position. Failure to engage the transfer shift lever in 2H, 4H or 4L could result in the vehicle moving unexpectedly, resulting in serious personal injury or property damage.**

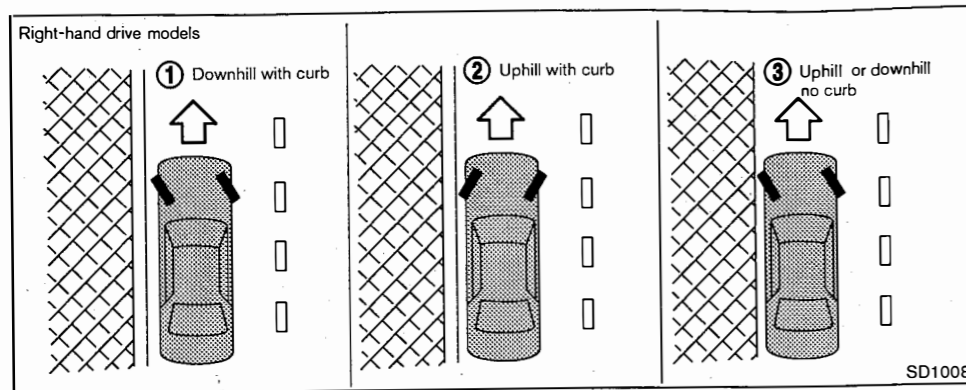
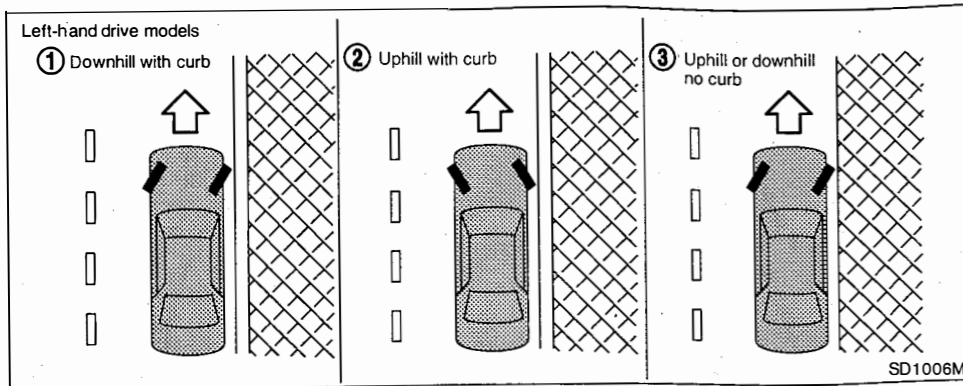

3. To help prevent the vehicle rolling into the street when parked on a sloping drive way, it is a good practice to turn the wheels as illustrated.

● **HEADED DOWNHILL WITH CURB: ①**

Turn the wheels into the curb and move the vehicle forward until the curb side wheel gently touches the curb.

● **HEADED UPHILL WITH CURB: ②**

Turn the wheels away from the curb and move the vehicle back until the curb side wheel gently touches the curb.

● **HEADED UPHILL OR DOWNHILL, NO CURB: ③**

Turn the wheels toward the side of the road so the vehicle will move away from the center of the road if it moves.

4. Turn the ignition key to the LOCK position and remove the key.

## TRAILER TOWING

Your new vehicle was designed to be used primarily to carry passengers and luggage.

Towing a trailer will place additional loads on your vehicle's engine, drive train, steering, braking and other systems. The towing of a trailer will exaggerate other conditions such as sway caused by crosswinds, rough road surfaces or passing trucks.

Your driving style and speed must be adjusted according to the circumstances. Before towing a trailer, see a NISSAN dealer for an explanation about the proper use of towing equipment.

## OPERATING PRECAUTIONS

- Avoid towing a trailer during the break-in period.
- Before driving, make sure that the lighting system of the trailer works properly.
- Observe the legal maximum speeds for trailer operation. (For example, below 100 km/h (62 MPH) for Europe.)
- Avoid abrupt starts, accelerations and stops.
- Avoid sharp turns and lane changes.
- Always drive your vehicle at a moderate speed.
- Take note of the trailer manufacturer's instructions.

● Choose proper coupling devices (trailer hitch, safety chain, roof carrier, etc.) for your vehicle and trailer.

● Never allow the total trailer load (trailer weight plus its cargo weight) to exceed the maximum set for the coupling device. See a NISSAN dealer for more information.

● The trailer must be loaded so that heavy goods are placed over the axle. The maximum allowable vertical load on the trailer hitch must not be exceeded.

● Have your vehicle serviced more often than at the intervals specified in a separate maintenance booklet.

- Trailer towing requires more fuel than under normal circumstances because of a considerable increase in traction power and resistance.
- Use the 4L position when starting out or driving up a steep slope.

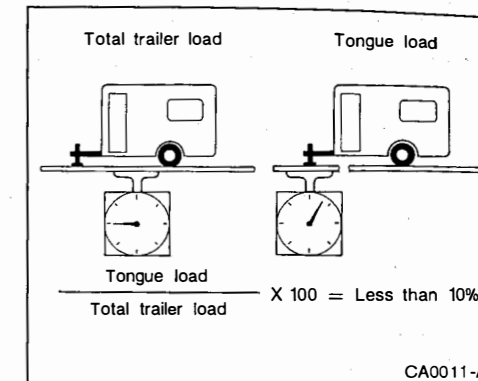

## MAXIMUM LOAD LIMITS (for Australia)

Maximum trailer loads (including tires and other loaded equipment):

1. Never allow the total trailer load to exceed:

### Wagon and Hardtop models:

- The maximum 750 kg (1,654 lb) for a trailer without brakes.
- ZD30DDTi engine/Manual Transmission (MT) model — The maximum 3,200 kg (7,056 lb) for a trailer with brakes.
- ZD30DDTi engine/Automatic Transmission (AT) model — The maximum 2,500 kg (5,513 lb) for a trailer with brakes.

lb) for a trailer with brakes.

- Except for ZD30DDTi engine model — The maximum 3,500 kg (7,718 lb) for a trailer with brakes.

#### Pickup model:

- The maximum 750 kg (1,654 lb) for a trailer without brakes.
- The maximum 3,200 kg (7,056 lb) for a trailer with brakes.

2. The total trailer load must be lower than the following three values even if it does not exceed the maximum permissible trailer loads.

- Towing capacity displayed on a tow-bar.
- Trailer's gross vehicle mass marked on a coupling body.
- Gross vehicle mass marked on a trailer data plate.

The maximum trailer load which can be towed by your vehicle depends on the towing equipment fitted to the vehicle. Therefore, it is important to not only have the correct equipment fitted but also to use it correctly. Towing loads greater than the value specified for your vehicle or using towing equipment which is not provided by NISSAN could seriously affect the handling and/or performance of your vehicle.

Vehicle damage resulting from improper towing procedures is not covered by NISSAN warranties. Information on trailer towing and the required equipment should be obtained from a NISSAN dealer.

#### Maximum tongue load

Never allow the tongue load to exceed 10% of the total trailer load. If the tongue load exceeds 10%, rearrange the cargo in the trailer.

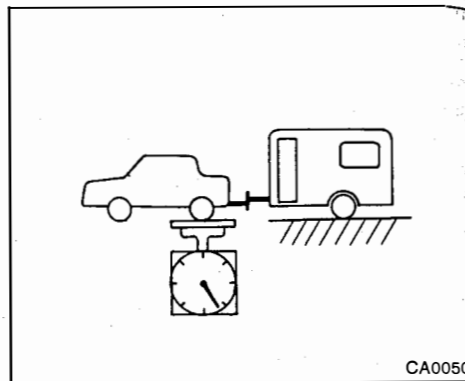

#### Maximum rear gross axle weight

The rear gross axle weight must not exceed the Gross Axle Weight Rating (GAWR).

#### GAWR:

##### Rear — Wagon and Hardtop models

1,800 kg (3,969 lb)

##### Rear — Pickup model

- 1,800 kg (3,969 lb) for coil spring suspension model
- 2,240 kg (4,939 lb) for leaf spring suspension model with 265/75R16 tires

- 2,270 kg (5,005 lb) for leaf spring suspension model with 7.50R16 or 235/85R16 tires

The trailer must be loaded so that heavy goods are placed over the axle.

#### TIRE PRESSURE

When towing a trailer, inflate the vehicle tires to the maximum recommended COLD tire pressure indicated on the tire placard (full loading shown on the tire placard).

#### SAFETY CHAINS

Always use a suitable chain between the vehicle and trailer. The chain should be crossed and should be attached to the hitch, not to the vehicle bumper or axle. Be sure to leave enough slack in the chain to permit turning corners.

#### TRAILER BRAKES

Ensure that trailer brakes are installed as required by local regulations. Also check that all other trailer equipment conforms to local regulations.

Always block the wheels on both the vehicle and trailer when parking. Apply the hand brake on the trailer if equipped. Parking on a steep slope is not recommended.

## VEHICLE SECURITY

When leaving your vehicle unoccupied:

- Always take the key with you — even when leaving the vehicle in your own garage.
- Close all windows completely and lock all doors.
- Always park your vehicle where it can be seen. Park in a well lit area during the night.
- If the security system is equipped, use it — even for a short period.
- Never leave children or pets in the vehicle unattended.
- Never leave valuables inside the vehicle. Always take valuables with you.
- Never leave the vehicle documents in the vehicle.
- Never leave articles on a roof rack. Remove them from the rack and keep and lock them in the luggage compartment or inside the vehicle.
- Never leave the spare key in the vehicle.

## BRAKE SYSTEM

The brake system has two separate hydraulic circuits. If one circuit malfunctions, you will still have braking ability at two wheels.

### BRAKE PRECAUTIONS

#### Vacuum assisted brakes

The brake booster aids braking by using engine vacuum. If the engine stops, you can stop the vehicle by depressing the foot brake pedal. However, greater foot pressure on the foot brake pedal will be required to stop the vehicle. The stopping distance will be longer.

If the engine is not running or is turned off while driving, the power assisted brakes will not function. Braking will be harder.



#### WARNING:

**Do not coast with the engine stopped.**

#### Using brakes

Avoid resting your foot on the foot brake pedal while driving. This will overheat the brakes, wear out the brake linings/pads faster, and increase fuel consumption.

To help reduce brake wear and to prevent the brakes from overheating, reduce speed and downshift to a lower gear before going down a slope or long grade. Overheated brakes may

reduce braking performance and could result in loss of vehicle control.

While driving on a slippery surface, be careful when braking, accelerating or downshifting. Abrupt braking or acceleration could cause the wheels to skid and result in an accident.

### Wet brakes

When the vehicle is washed or driven through water, the brakes may get wet. As a result, your braking distance will be longer and the vehicle may pull to one side during braking.

To dry the brakes, drive the vehicle at a safe speed while lightly depressing the brake pedal to heat up the brakes. Do this until the brakes return to normal. Avoid driving the vehicle at high speeds until the brakes function correctly.

### Driving uphill

When starting on a steep grade, it is sometimes difficult to operate both the brake and clutch. Apply the parking brake to hold the vehicle. Do not slip the clutch. When ready to start, slowly release the parking brake while depressing the accelerator pedal and releasing the clutch pedal.

### Driving downhill

The engine braking action is effective for controlling the vehicle while descending hills. For manual transmission model, the shift lever

should be placed in the lower speed position prior to descending. For 4-speed automatic transmission model, the "2" or "1" position should be selected. For 5-speed automatic transmission model, the manual shift mode should be selected.

Driving at the upland  
(diesel engine model except for high altitude specification model)

**ZD30DDTi engine model:** Avoid driving at an altitude higher than 3,000 m (9,843 ft).

**TD42 engine model:** Avoid driving at an altitude higher than 2,000 m (6,562 ft).

**TD42Ti engine model:** Avoid driving at an altitude higher than 1,800 m (5,906 ft).

It may cause loss of emission control effect and driveability, or hard to start the engine.

### ANTI-LOCK BRAKING SYSTEM (ABS)

#### **WARNING:**

- **The Anti-lock Braking System (ABS) is a sophisticated device, but it cannot prevent accidents resulting from careless or dangerous driving techniques. It can help maintain vehicle control during braking on slippery surfaces. Remember**

**that stopping distances on slippery surfaces will be longer than on normal surfaces even with ABS. Stopping distances may also be longer on rough, gravel or snow covered roads, or if you are using tire chains. Always maintain a safe distance from the vehicle in front of you. Ultimately, the driver is responsible for safety.**

- **Tire type and condition may also affect braking effectiveness.**
  - **When replacing tires, install the specified size of tires on all four wheels.**
  - **When installing a spare tire, make sure that it is the proper size and type as specified on the tire placard. (See "Tire placard" in the "9. Technical information" section.)**
  - **For detailed information, see "Tires and wheels" in the "8. Maintenance and do-it-yourself" section.**

The Anti-lock Braking System (ABS) controls the brakes so the wheels do not lock during hard braking or when braking on slippery surfaces. The system detects the rotation speed at each wheel and varies the brake fluid pressure to prevent each wheel from locking and sliding. By

preventing each wheel from locking, the system helps the driver maintain steering control and helps to minimize swerving and spinning on slippery surfaces.

**If a tire slips on rough roads for more than 40 seconds, the ABS warning light may come on. Turn the ignition switch to the ON position, restart the engine and drive the vehicle at speeds above 30 km/h (20 MPH). If the ABS warning light does not go out, have the vehicle checked at a NISSAN dealer.**

### Using system

Depress the brake pedal and hold it down. Depress the brake pedal with firm steady pressure, but do not pump the brakes. The ABS will operate to prevent the wheels from locking up. Steer the vehicle to avoid obstacles.

#### **WARNING:**

**Do not pump the brake pedal. Doing so may result in increased stopping distances.**

### Self-test feature

The ABS includes electronic sensors, electric pumps, hydraulic solenoids and a computer. The computer has a built-in diagnostic feature that tests the system each time you start the engine and move the vehicle at a low speed in forward

or reverse. When the self-test occurs, you may hear a "clunk" noise and/or feel a pulsation in the brake pedal. This is normal and does not indicate a malfunction. If the computer senses a malfunction, it switches the ABS off and illuminates the ABS warning light on the instrument panel. The brake system then operates normally, but without anti-lock assistance.

If the ABS warning light illuminates during the self-test or while driving, have the vehicle checked by a NISSAN dealer.

### Normal operation

The ABS operates at speeds above 5 to 10 km/h (3 to 6 MPH). The speed varies according to road conditions.

When the ABS senses that one or more wheels are close to locking up, the actuator rapidly applies and releases hydraulic pressure. This action is similar to pumping the brakes very quickly. You may feel a pulsation in the brake pedal and hear a noise from under the hood or feel a vibration from the actuator when it is operating. This is normal and indicates that the ABS is operating properly. However, the pulsation may indicate that road conditions are hazardous and extra care is required while driving.

## COLD WEATHER DRIVING

- **Wet ice (0°C, 32°F and freezing rain), very cold snow or ice can be slick and very hard to drive on. You will have a lot less traction or "grip" under these conditions. Try to avoid driving on wet ice until the road is salted or sanded.**
- **Whatever the condition, drive with caution and accelerate gently. If you accelerate too fast, the drive wheels will spin and will lose even more traction.**
- **Allow more stopping distance under these conditions. You will want to start braking sooner than on dry pavement.**
- **Allow greater following distances on slippery roads.**
- **Watch for slippery spots (glare ice). These may appear on an otherwise clear road in shaded areas. If you see a patch of ice ahead, brake before you are on it. Try not to brake while you are actually on the ice, and avoid any sudden steering maneuvers.**

### BATTERY

If the battery is not fully charged during extremely cold weather conditions, the battery fluid may freeze and damage the battery. To maintain maximum efficiency, the battery should be checked regularly. For details, see "Battery" in

the "8. Maintenance and do-it-yourself" section.

## ENGINE COOLANT

If the vehicle is to be left outside without anti-freeze, drain the cooling system by opening the drain plugs located under the radiator and on the engine block. Refill before operating the vehicle. See "Changing Engine Coolant" in the "8. Maintenance and do-it-yourself" section.

## TIRE EQUIPMENT

1. The SUMMER tires are of a tread design to provide superior performance on dry pavement. However, the performance of these tires will be substantially reduced in snowy and icy conditions. If you operate your vehicle on snowy or icy roads, NISSAN recommends the use on all four wheels of MUD & SNOW or ALL SEASON tires. Consult a NISSAN dealer for the tire type, size, speed rating and availability information.
2. For additional traction on icy roads, studded tires may be used. However, some countries, provinces and states prohibit their use. Check local, state and provincial laws before installing studded tires.

**Skid and traction capabilities of studded snow tires, on wet or dry surfaces, may be poorer than that of non-studded snow tires.**

3. Snow chains may be used if desired. Make sure they are of proper size for the tires on your vehicle and are installed according to the chain manufacturer's suggestions. Use chain tensioners when recommended by the tire chain manufacturer to ensure a tight fit. Loose end links of the tire chain must be secured or removed to prevent the possibility of whipping action damage to the fenders or undercarriage. In addition, drive at a reduced speed, otherwise, your vehicle may be damaged and/or vehicle handling and performance may be adversely affected.

## SPECIAL WINTER EQUIPMENT

It is recommended that the following items be carried in the vehicle during winter:

1. A scraper and stiff-bristled brush to remove ice and snow from the windows and wiper blades.
2. A sturdy, flat board to be placed under the jack to give it firm support.
3. A shovel to dig the vehicle out of snowdrifts.
4. Extra window washer fluid to refill the reservoir tank.

Engine block heater (if so equipped)



### WARNING:

**Do not use your heater with an ungrounded electrical system or two-pronged (cheater) adapters. You can be injured by an electrical shock if you use an ungrounded connection.**

## PARKING BRAKE

When parking in the area where the outside temperature is below 0°C (32°F), do not apply the parking brake to prevent it from freezing. For safe parking:

- Place the selector lever in the "P" (Park) position. (Automatic Transmission model)
- Place the shift lever in the "1" (1st) or "R" (Reverse) gear. (Manual Transmission model)
- Securely block the wheels.

## CORROSION PROTECTION

Chemicals used for road surface de-icing are extremely corrosive and will accelerate corrosion and the deterioration of underbody components such as the exhaust system, fuel and brake lines, brake cables, floor pan and fenders.

**In winter, the underbody must be cleaned periodically. For additional information, see "Corrosion protection" in the "7. Ap-**

**pearance and care" section of this Manual.**

For additional protection against rust and corrosion, which may be required in some areas, consult a NISSAN dealer.

## WINCH (if so equipped)

### PRECAUTIONS ON WINCH



### WARNING:

- Never use the winch in an operation where personal safety is endangered.
- Never use the winch for lifting or moving persons.

### CAUTION:

- When operating the winch, be sure not to touch the wire and winch body.
- In every winching situation make sure that the anchor you are using is able to withstand the load.

**Always stand clear of the winch cable and load while pulling.**

**Keep spectators and the operator at a safe distance. A flying cable and hook are dangerous.**

- Winching can be dangerous. Avoid hasty operation. Always give proper attention to the load, hook wire rope and winch.
- When anchoring the pulling vehicle, apply the parking brake, use the foot brake and block the wheels.
- If oil or grease comes into contact with

**any part of the brake assembly, completely clean before using the winch.**

- Before each winching operation, inspect the remote control lead for damage.

Wire safety

### CAUTION:

- Never apply a load above the following winch capacity and time limit.

Winch capacity		17,653
	N (kg, lb)	(1,800, 3,969)
Time limit	minute	2.5

- Do not extend the wire fully.
- When applying a load, be sure that the wire has left more than five turns at the right on the drum.
- When retrieving or spooling in wire rope, be sure to distribute the wire rope evenly and tightly on the drum.
- Always wind the wire on and take off from the lower side of the drum.

**Winding the wire on and off the upper side of the drum causes the brake to be inoperative.**

- Do not apply a heavy load abruptly to



the winch. The load should be increased gradually.

- Keep the wire straight, in line with the vehicle, when the winch is under a load.
- After each winching operation, check the wire for signs of wear, breakage or kinking. If necessary, replace the wire so the winch is ready for immediate use.

#### WINCH OPERATION

##### CAUTION:

- Keep the engine running while operating the winch. Avoid using the winch for extended periods of time.
- Do not use the winch where water can enter the control box (located above the winch).
- Shift the shift lever to the N position for a manual transmission model, and shift the selector lever to the P position for an automatic transmission model.
- Shift the transfer shift lever to the N position (between 4H and 4L position).

When the winch starts operating, white smoke may come from the motor. This is not abnormal. Smoke decreases with time.

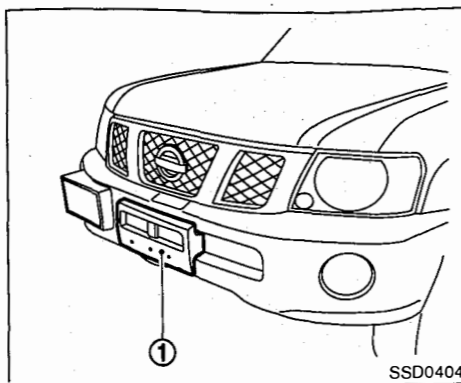

Type A

SSD0404

#### Winch cover

Remove the cover ① before using the winch.

##### CAUTION:

Be sure to attach the cover when the winch is not in use.

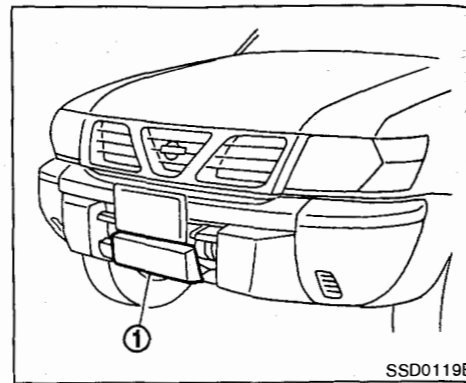

Type B

SSD0119B

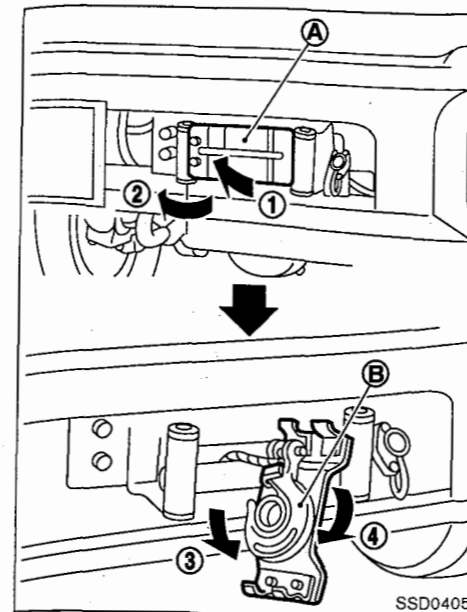

#### Hook holder

The winch hook is stored in the back side of the hook holder (A). To remove the holder, push it toward the left (1) and turn the drum roller outward (2). Then remove the holder (3). Turn and release (4) the hook (B) from the holder.

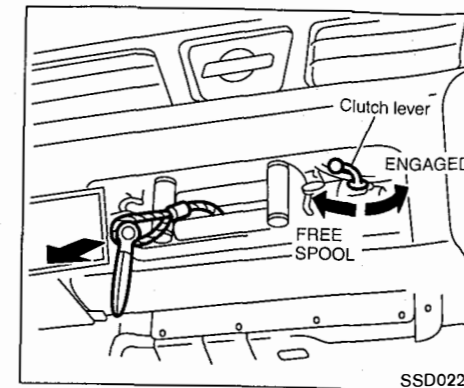

#### Clutch lever

##### FREE SPOOL position:

The drum can be turned by hand in this position. When extending the wire and rewinding it after use, select this position and turn the drum manually.

##### ENGAGED position:

In this position, electric motor power is transmitted to the drum by operating the remote control switch.

Before operating the winch with the remote control switch, be sure to turn the clutch lever to this position.

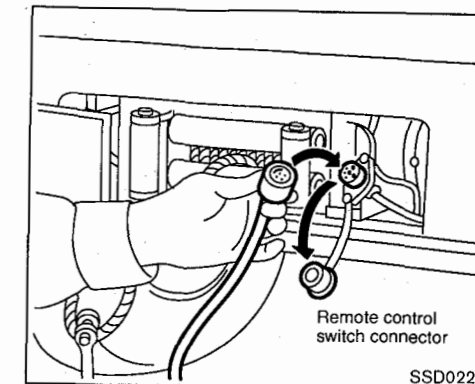

#### Remote control switch

Pull off the cap from the socket on the winch, and attach the remote control switch connector to it.

When the winch is not in use, disconnect the remote control switch. Then store it in a suitable area.

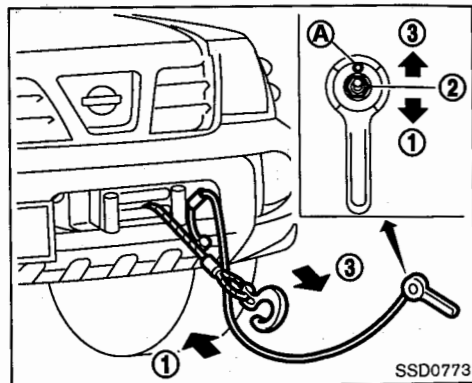

The greater the load, the sooner the brake activates.

The remote control switch has three positions: "WIND" ①, "NEUTRAL" ② and "UNWIND" ③. (A : Warning light)

When the switch is released from the "WIND" or "UNWIND" position, it will automatically return to the "NEUTRAL" position.

#### Automatic brake:

Any time the remote control switch is in the "NEUTRAL" position, the brake will automatically activate against a load.

Releasing the remote control switch from the "UNWIND" position under a load will not cause the brake to activate immediately. The wire will unwind approximately 10 cm (3.9 in) by inertia.

## 6 In case of emergency

Flat tire .....	6-2	Push starting .....	6-9
Stopping the vehicle .....	6-2	If your vehicle overheats .....	6-10
Preparing tools and spare tire .....	6-2	Fire extinguisher .....	6-10
Blocking wheels .....	6-5	Towing your vehicle .....	6-11
Removing the tire .....	6-5	Towing precautions .....	6-11
Installing spare tire.....	6-7	Towing recommended by NISSAN .....	6-11
Stowing the damaged tire and tools .....	6-8	Towing point .....	6-12
Jump starting .....	6-8	Pintle hook (if so equipped) .....	6-12

## FLAT TIRE

If you have a flat tire, follow the instructions below.

### STOPPING THE VEHICLE

1. Safely move the vehicle off the road away from traffic.
2. Turn on the hazard warning flashers.
3. Park on a level surface and apply the parking brake. Shift the manual transmission into R (Reverse) position [automatic transmission in P (Park)].



#### WARNING:

 The transfer shift lever must be in the 2H, 4H or 4L position to prevent the vehicle from rolling. Never place it in the N (Neutral) position.

4. Turn off the engine.
5. Have all passengers get out of the vehicle and stand in a safe place, away from traffic and clear of the vehicle.



#### WARNING:

- Make sure that the parking brake is securely applied and the manual transmission is shifted into the R (Reverse) position, or the automatic transmission into the P (Park) position.

- Never change tires when the vehicle is on a slope, ice or slippery areas. This is hazardous.
- Never change tires if oncoming traffic is close to your vehicle. Wait for professional road assistance.

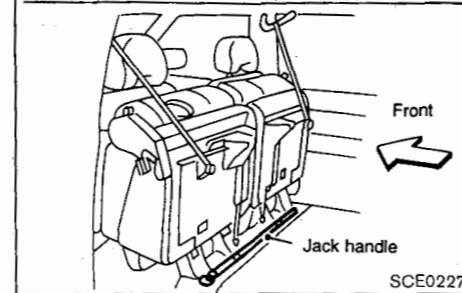
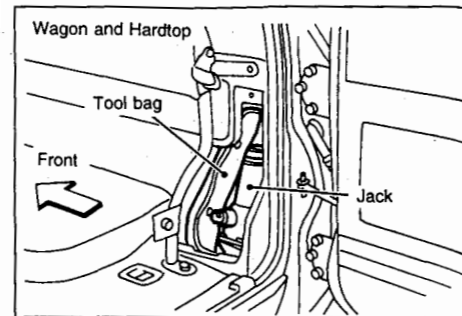

### PREPARING TOOLS AND SPARE TIRE

Remove jacking tools and spare tire from storage area.

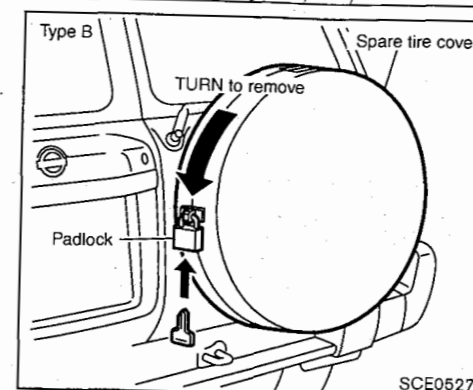
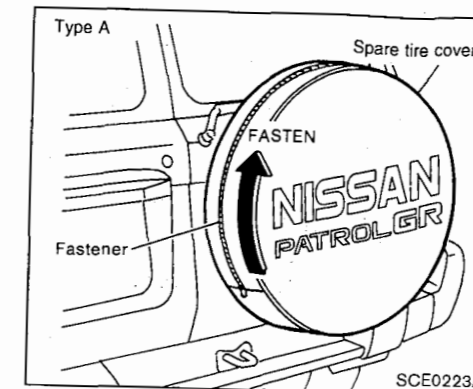
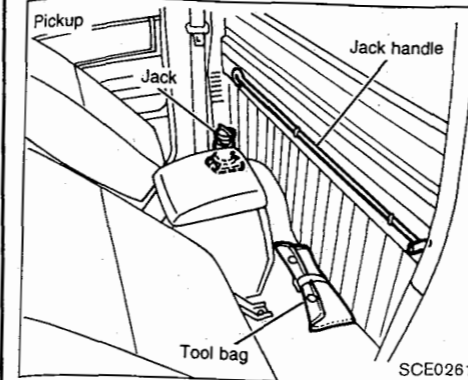

Removing the spare tire cover (if so equipped)

The spare tire cover cannot be removed or attached unless the spare tire is detached from the spare tire carrier.

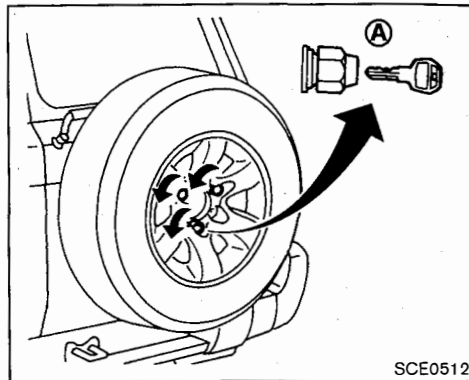

SCE0512

Wagon and Hardtop

### Removing the spare tire

#### Wagon and Hardtop models:

Loosen the three nuts to remove the spare tire from the back door.

If nut **A** is equipped with the key cylinder, unlock it using the key before removing.

When installing the tire, tighten securely.

#### Tightening torque of bolts:

50 to 68 N·m  
(5.1 to 6.9 kg-m, 37 to 50 ft-lb)

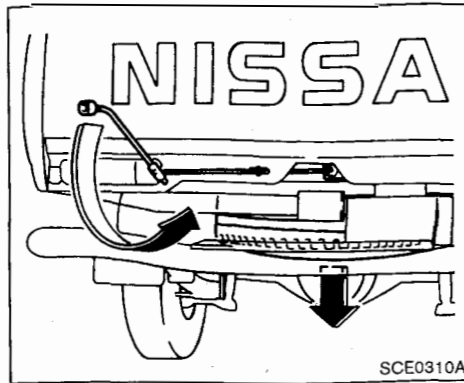

SCE0310A

Pickup — Type A

#### Pickup models:

##### Type A

Remove the spare tire using the jack rod and wheel nut wrench as shown.

- Be careful not to loosen the hanger bolt excessively; otherwise the hanger will fall suddenly.
- When installing the tire, tighten securely.

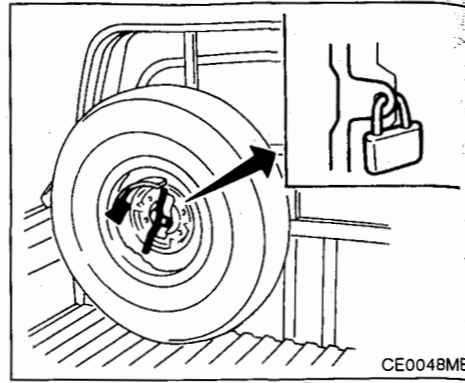

CE0048MB

Pickup — Type B

##### Type B

Remove the spare tire turning the handle as shown. (A padlock can be put on the handle.)

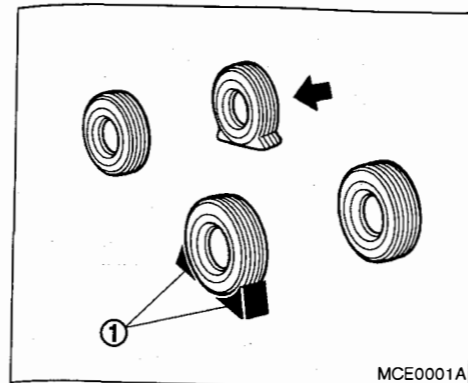

MCE0001A

### BLOCKING WHEELS

Place suitable blocks **1** at both the front and back of the wheel diagonally opposite the flat tire **←** to prevent the vehicle from moving when it is jacked up.



#### WARNING:

Be sure to block the wheel as the vehicle may move and could cause personal injury.

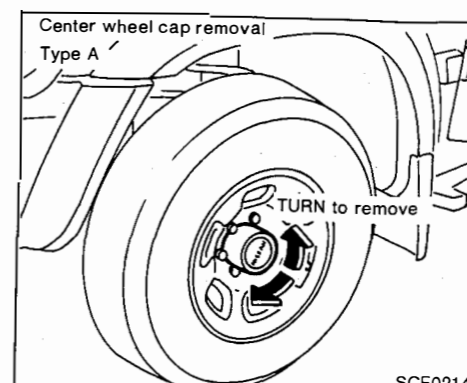

SCE0214

Center wheel cap removal  
Type A

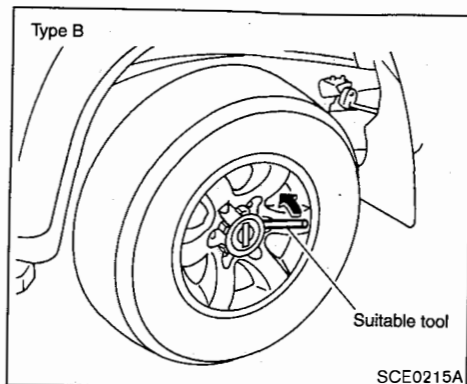

SCE0215A

Type B

Suitable tool

### REMOVING THE TIRE

Removing the wheel cap (if so equipped)

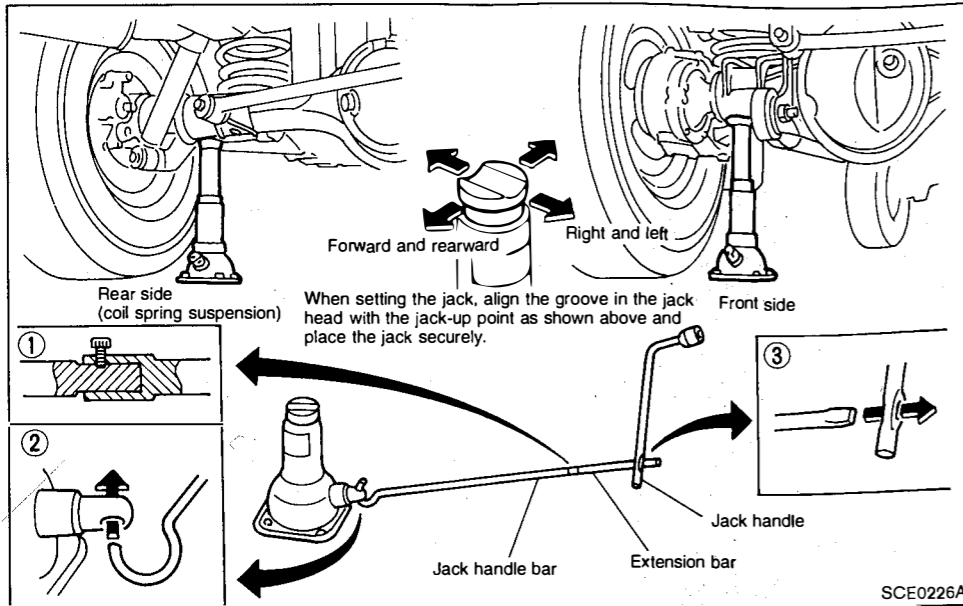

### Jacking up the vehicle

#### CAUTION:

Carefully read the caution label attached to the jack body and the following instructions.

1. Place the jack directly under the jack-up point as illustrated above.

#### **WARNING:**

The jack should be used on firm level ground. Be sure to block the wheel as instructed earlier in this section.

2. Loosen each wheel nut one or two turns by turning counterclockwise with the wheel nut wrench. **Do not remove the wheel nuts**

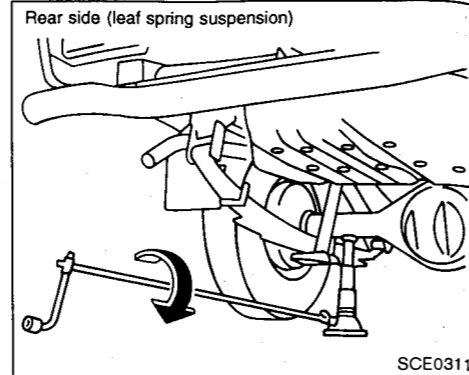

until the tire is off the ground.

3. Carefully raise the vehicle until the tire clears the ground.

#### **WARNING:**

- Do not get under a vehicle that is supported only by a jack: Use vehicle support stands.

- Use only the jack provided with your vehicle to lift the vehicle. Do not use the jack provided with another vehicle for your vehicle.

The jack is designed only for lifting your vehicle during a tire change.

- Use the correct jack up points; never use any other part of the vehicle for jack support.

- Never jack up the vehicle more than necessary.

- Never use blocks on or under the jack.

- Do not start or run engine while vehicle is on the jack, as it may cause the vehicle to move. This is especially true for vehicles with limited slip differential carriers or rear differential lock-up device.

- Do not allow passengers to stay in the vehicle while it is on the jack.

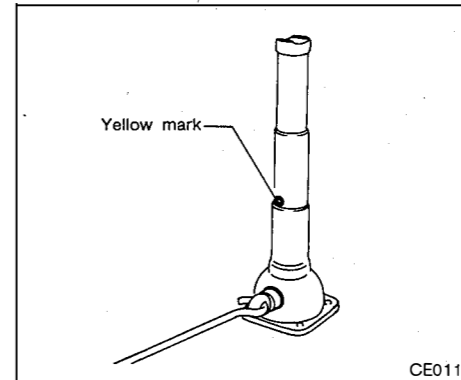

- Do not extend the jack further than the yellow mark which appears on the cylinder.

### Removing the tire

Remove the wheel nuts, and then remove the wheel. Do not remove the brake drum with the wheel.

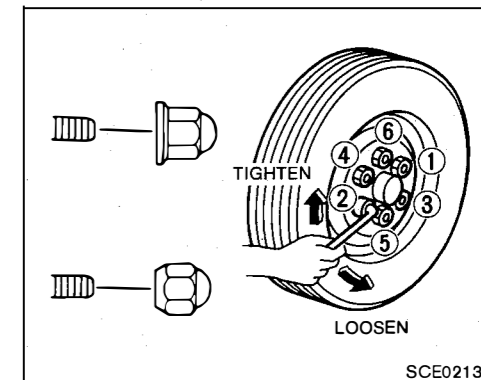

### INSTALLING SPARE TIRE

#### **WARNING:**

- Never use wheel nuts which are not provided with your vehicle. Incorrect wheel nuts or improperly tightened wheel nuts may cause the wheel to become loose or come off. This could cause an accident.

- Never use oil or grease on the wheel studs or nuts. This may cause the wheel nuts to become loose.

1. Clean any mud or dirt from the surface between the wheel and hub.

2. Carefully put the spare tire on and tighten the

wheel nuts with your fingers. Check that all the wheel nuts contact the wheel surface horizontally.

3. Tighten the wheel nuts alternately and evenly in the sequence illustrated (① - ⑥), more than 2 times with the wheel nut wrench, until they are tight.
4. Lower the vehicle slowly until the tire touches the ground.
5. Tighten the wheel nuts securely, with the wheel nut wrench, in the sequence illustrated.
6. Lower the vehicle completely.

**Tighten the wheel nuts to the specified torque with a torque wrench as soon as possible.**

**Wheel nut tightening torque:**  
133 N-m (14 kg-m, 98 ft-lb)

**The wheel nuts must be kept tightened to specification at all times. It is recommended that the wheel nuts be tightened to specification at each lubrication interval.**

**Adjust tire pressure to the COLD pressure.**

**COLD pressure:**

**After vehicle has been parked for three**

**hours or more or driven less than 1.6 km (1 mile).**

**COLD tire pressures are shown on the tire placard affixed to the glove box lid or driver side center pillar.**



**WARNING:**

**Retighten the wheel nuts when the vehicle has been driven for 1,000 km (600 miles) (also in cases of a flat tire, etc.).**

### STOWING THE DAMAGED TIRE AND TOOLS

Securely store the spare tire and jacking equipment in the vehicle.



**WARNING:**

**Always make sure that the spare tire and jacking equipment are properly secured after use. Such items can become dangerous projectiles in a serious accident.**

## JUMP STARTING

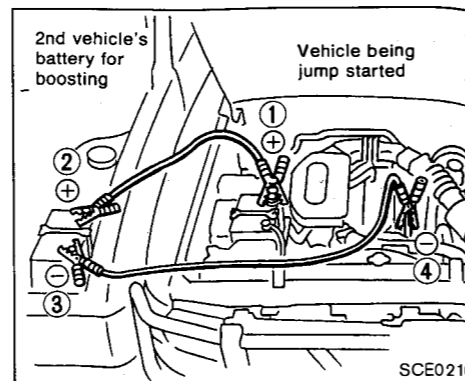

**CAUTION:**

**Use a battery rated at 12 volts for a booster.**

1. Remove vent caps on the battery (if so equipped). Cover the battery with an old cloth as shown.
2. Connect jumper cables in the sequence as illustrated.

**CAUTION:**

**An incorrect connection could result in damage to the charging system.**

3. Start the engine of the other vehicle and let it run for a few minutes. Keep the engine speed

at about 2,000 rpm, and start your engine in the normal manner.

4. After starting your engine, carefully disconnect the negative cable and then the positive cable.
5. Replace the vent caps (if so equipped).

## PUSH STARTING

**CAUTION:**

- **Automatic transmission models cannot be started by pushing. This may cause transmission damage.**
- **Three way catalyst or oxidation catalyst equipped models should not be started by pushing since the catalysts may be damaged.**
- **Never try to start the vehicle by towing it; when the engine starts, the forward surge could cause the vehicle to collide with the tow vehicle.**

Gasoline engine with manual transmission (except three way catalyst equipped models)

1. Turn the ignition switch to ON.
2. Hold the clutch pedal fully depressed and shift into second or third gear. Place the transfer shift lever in 2H and free-running hubs (if so equipped) in the AUTO or FREE position.
3. Hold the accelerator pedal about halfway.
4. Start pushing, and when the vehicle reaches a speed of about 16 km/h (10 MPH), slowly release the clutch pedal to start the engine.

Diesel engine with manual transmission (except ZD30DDTi engine models)

1. Turn the ignition switch to the OFF (not LOCK) position.
2. Hold the clutch pedal fully depressed and shift into second or third gear. Place the transfer shift lever in 2H and free-running hubs (if so equipped) in the AUTO or FREE position.
3. Hold the accelerator pedal fully depressed.
4. Start pushing, and when the vehicle reaches a speed of about 16 km/h (10 MPH), turn the ignition key to ON and slowly release the clutch pedal to start the engine.

## IF YOUR VEHICLE OVERHEATS



### WARNING:

To avoid the danger of being scalded, never remove the radiator cap while the engine is still hot.

1. Move the vehicle safely off the road, apply the parking brake and move the gearshift lever to neutral (automatic transmission "P").

### Do not stop the engine.

2. Turn off the air conditioner switch. Open all the windows, move the heater or air conditioner temperature control to "maximum hot" and fan control to "high speed".
3. Visually check drive belts for damage or looseness. Also check if the cooling fan is running. The radiator hoses and radiator should not leak water.



### WARNING:

Be careful not to allow your hands, hair or clothing to come into contact with the fan, belts, or other moving parts.

If coolant is leaking, the cooling fan belt is missing or loose, or the cooling fan does not run, stop the engine.

4. After the engine cools down, check the coolant level in the reservoir tank with the engine running. Add coolant to the reservoir tank if

necessary. Have your vehicle repaired at a NISSAN dealer.

## FIRE EXTINGUISHER (if so equipped)

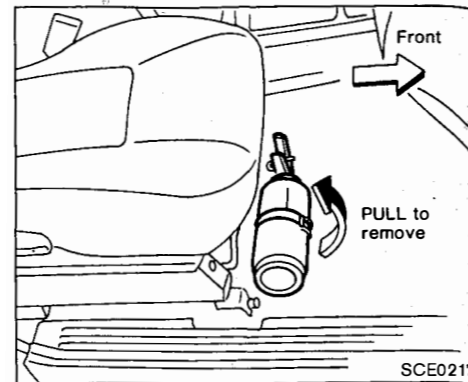

When you have to use the fire extinguisher, follow the instructions below.

1. Pull out the safety pin.
2. Point the nozzle at the base of fire.
3. Grip the lever.

## TOWING YOUR VEHICLE

When towing your vehicle, local regulations for towing must be followed. Incorrect towing equipment could damage your vehicle. To assure proper towing and to prevent accidental damage to your vehicle, NISSAN recommends that you have professional road assistance personnel tow your vehicle. It is advisable to have the professional road assistant carefully read the following precautions.

### TOWING PRECAUTIONS

Never tow four-wheel drive (4WD) model with any of the wheels on the ground as this may cause serious and expensive damage to the drive train.

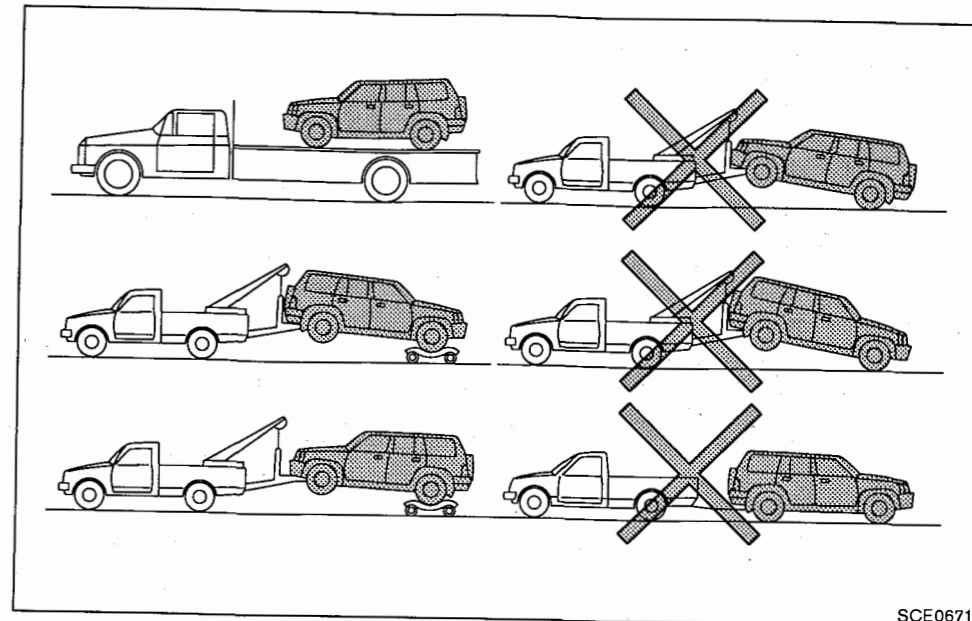

### TOWING RECOMMENDED BY NISSAN

NISSAN recommends that your vehicle be towed with all wheels off the ground as illustrated or place the vehicle on a flatbed truck.

### CAUTION:

Never tow 4WD model with any of the wheels on the ground. Doing so will cause serious and expensive damage to the powertrain.

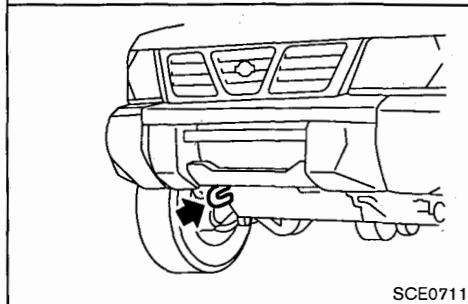
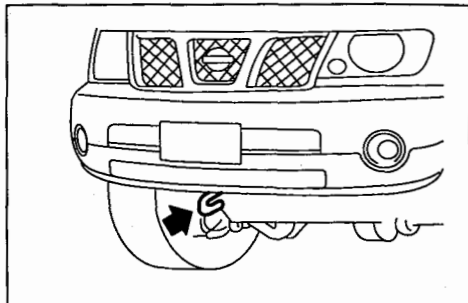

SCE0711

Front

### TOWING POINT

- Use the towing hooks **only**, not other parts of the vehicle. Otherwise, the vehicle body will be damaged.
- Use the towing hooks **only** to free a vehicle stuck in sand, snow, mud, etc. **Never** tow

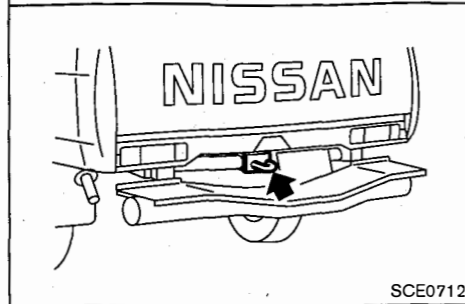
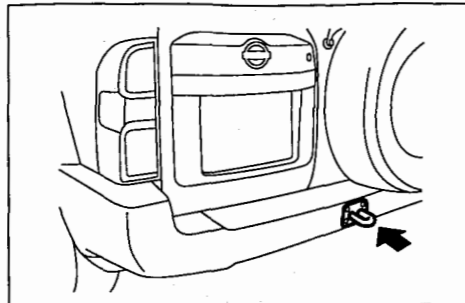

SCE0712

Rear

the vehicle for long distances using only the towing hooks.

- The towing hook is under tremendous force when used to free a stuck vehicle. Always pull the cable straight out from the front or rear of the vehicle. **Never** pull on the hook at a sideways angle.

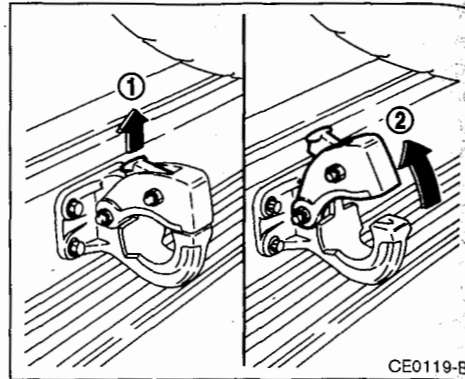

CE0119-B

### PINTLE HOOK (if so equipped)

- **Do not use the pintle hook for towing another vehicle, trailer, etc. This hook is designed for use only in an emergency, for example, when getting the vehicle out of the mud.**
- **Make sure to close the pintle hook before opening or closing the back door.**

## 7 Appearance and care

Cleaning exterior .....	7-2	Cleaning interior .....	7-3
Washing .....	7-2	Glass .....	7-4
Removing spots .....	7-2	Plastic parts .....	7-4
Waxing .....	7-2	Seat belts .....	7-4
Glass .....	7-2	Corrosion protection .....	7-5
Underbody .....	7-3	Most common factors contributing to vehicle	
Wheels .....	7-3	corrosion .....	7-5
Aluminum alloy wheels.....	7-3	Environmental factors influence the rate of	
Chrome parts .....	7-3	corrosion .....	7-5
		To protect your vehicle from corrosion .....	7-5



## CLEANING EXTERIOR

In order to maintain the appearance of your vehicle, it is important to take proper care of it.

In the following cases, please wash your vehicle as soon as possible to protect the paint surface.

- After a rainfall to prevent possible damage from acid rain
- After driving on coastal roads
- When things such as soot, bird droppings, tree sap, metal particles or bugs get on the paint surface
- When dust or mud builds up on the surface

Whenever possible, store or park your vehicle inside a garage or in a covered area.

When it is necessary to park outside, park in a shady area or protect the vehicle with a body cover.

**Be careful not to scratch the paint surface when putting on or removing the body cover.**

### WASHING

Wash dirt off with a wet sponge and plenty of water. Clean the vehicle thoroughly using a mild soap or detergent (a special vehicle soap or general purpose dish-washing liquid) mixed with clean, lukewarm (never hot) water.

### CAUTION:

- **Do not use strong household soap, strong chemical detergents, gasoline or solvents.**
- **Do not wash the vehicle in direct sunlight or while the vehicle body is hot, as the surface may become water-spotted.**
- **Avoid using tight-napped or rough cloths, such as washing mitts. Care must be taken when removing caked-on dirt or other foreign substances so that the paint surface is not scratched or damaged.**

Rinse the vehicle thoroughly with plenty of clean water.

Inside flanges, seams and folds on the doors, hatches and hood are particularly vulnerable to the effects of road salt. Therefore, these areas must be regularly cleaned. Take care that the drain holes in the lower edge of the door are open. Spray water under the body and in the wheel wells to loosen the dirt and wash away road salt.

A damp chamois can be used to dry the vehicle to avoid water spots.

### REMOVING SPOTS

Remove tar and oil spots, industrial dust, insects,

and tree sap as quickly as possible from the surface of the paint to avoid lasting damage or staining. Special cleaning products are available at a NISSAN dealer or any automotive accessory store.

### WAXING

Regular waxing protects the paintwork and helps to retain new vehicle appearance.

A NISSAN dealer can assist you in choosing the proper product.

- Wax your vehicle only after a thorough washing. Follow the instructions supplied with the wax.
- Do not use a wax containing any abrasives, cutting compounds or cleaners that may damage the vehicle finish.
- If the surface does not polish easily, use a "road tar" remover and wax again.

**Machine compounding or aggressive polishing on a base coat/clear coat paint finish may dull the finish or leave swirl marks.**

Only apply black wax or black shoe polish to the black urethane or polypropylene bumper.

### GLASS

Use glass cleaner to remove smoke and dust film

from the glass surfaces. It is normal for glass to become coated with a film after the vehicle is parked in the hot sun. Glass cleaner and a soft cloth will easily remove this film.

### UNDERBODY

In areas where road salt is used in winter, it is necessary to clean the underbody regularly in order to prevent dirt and salt from building up and causing corrosion on the underbody and suspension. Before the winter period and again in the spring, the underseal must be checked and, if necessary, re-treated.

### WHEELS

- Wash the wheels when washing the vehicle to maintain their appearance.
- Clean the inner side of the wheels when the wheel is changed or the underside of the vehicle is washed.
- Do not use abrasive cleaners when washing the wheels.
- Inspect wheel rims regularly for dents or corrosion. This may cause loss of pressure or damage the tire bead.
- NISSAN recommends that the road wheels be waxed to protect against road salt in areas where it is used during winter.

### ALUMINUM ALLOY WHEELS

Wash the wheels regularly with a sponge dampened in a mild soap solution, especially during winter in areas where road salt is used. The salt residue from road salt could discolor the wheels if it is not washed off regularly.

### CAUTION:

**Follow the directions below to avoid staining or discoloring the wheels:**

- **Do not use a cleaner that uses strong acid or alkali contents to clean the wheels.**
- **Do not apply wheel cleaners to the wheels when they are hot. The wheel temperature should be the same as ambient temperature.**
- **Rinse the wheel to completely remove the cleaner within 15 minutes after the cleaner is applied.**

### CHROME PARTS

Clean all chrome parts regularly with a non-abrasive chrome polish to maintain the finish.

## CLEANING INTERIOR

Occasionally remove loose dust from the interior trim, plastic parts and seats using a vacuum cleaner or soft bristled brush. Wipe the vinyl and leather surfaces with a clean, soft cloth dampened in mild soap solution, then wipe clean with a dry soft cloth.

Regular care and cleaning is required in order to maintain the appearance of the leather.

Before using any fabric protector, read the manufacturer's recommendations. Some fabric protectors contain chemicals that may stain or bleach the seat material.

Use a soft cloth dampened only with water to clean the meter and gauge lens covers.

### CAUTION:

- **Never use benzine, thinner, or any similar material.**
- **Small dirt particles can be abrasive and damaging to leather surfaces and should be removed promptly. Do not use saddle soap, car waxes, polishes, oils, cleaning fluids, solvents, detergents or ammonia-based cleaners as they damage the leather's natural finish.**
- **Never use fabric protectors unless recommended by the manufacturer.**
- **Do not use glass or plastic cleaner on**

meter or gauge lens covers. It may damage the lens covers.

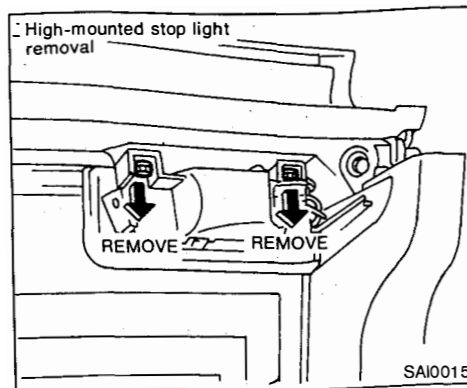

## GLASS

Use glass cleaner to remove smoke and dust film from the glass surfaces. It is normal for glass to become coated with a film after the vehicle is parked in the hot sun. Glass cleaner and a soft cloth will easily remove this film.

### CAUTION:

**When cleaning the inside of the window, do not use sharp-edged tools, abrasive cleaners or chlorine based disinfectant cleaners. They could damage electrical conductors or rear window defogger elements (if so equipped).**

## PLASTIC PARTS

Plastic parts can be cleaned with a mild soap solution. If the dirt cannot be easily removed, use a plastic cleaner. Do not use any solvents.

## SEAT BELTS

The seat belts can be cleaned by wiping them with a sponge dampened in a mild soap solution. Allow the belts to dry completely before using them. Do not allow wet belts to roll up in the retractor. NEVER use bleach, dye, or chemical solvents since these may severely weaken the seat belt webbing.

## CORROSION PROTECTION

### MOST COMMON FACTORS CONTRIBUTING TO VEHICLE CORROSION

1. The accumulation of moisture-retaining dirt and debris in body panel sections, cavities, and other areas.
2. Damage to paint and other protective coatings caused by gravel and stone chips or minor traffic accidents.

### ENVIRONMENTAL FACTORS INFLUENCE THE RATE OF CORROSION

#### Moisture

The accumulation of sand, dirt, and water on the underside of the body will accelerate corrosion. Floor covering which becomes wet will not dry satisfactorily in the vehicle and should be removed for drying to avoid the possibility of corrosion of the floor panels.

#### Relative humidity

Corrosion will be accelerated in areas of high relative humidity, especially those areas where the temperatures stay above freezing and where atmospheric pollution exists and road salt is used.

#### Temperature

A temperature increase will accelerate the rate of corrosion to those parts which are not well ventilated.

#### Air pollution

Industrial pollution, the presence of salt in the air in coastal areas, or heavy road salt use will accelerate the corrosion process. Road salt will also accelerate the disintegration of paint surfaces.

### TO PROTECT YOUR VEHICLE FROM CORROSION

- Wash and wax your vehicle often to keep the vehicle clean.
- Always check for minor damage to the paint and repair it as soon as possible.
- Keep drain holes at the bottom of the doors and tailgate open to avoid water accumulation.
- Check the underbody and inside the pick-box (Truck model). If any sand, dirt, or salt has accumulated, wash it off with water as soon as possible.

### CAUTION:

- **Never remove dirt, sand or other debris from the passenger compartment by**

**washing with a hose. Remove dirt with a vacuum cleaner or broom.**

- **Never allow water or other liquids to come in contact with electronic components inside the vehicle.**

Chemicals used for road surface de-icing are extremely corrosive. They accelerate corrosion and deterioration of underbody components such as the exhaust system, fuel and brake lines, brake cables, floor pan and fenders.

**In winter, the underbody must be cleaned periodically.**

For additional protection against rust and corrosion, which may be required in some areas, consult a NISSAN dealer.

## 8 Maintenance and do-it-yourself

Maintenance requirements .....	8-2	Spark plugs (gasoline engine model) .....	8-31
General maintenance .....	8-2	Replacing spark plugs .....	8-31
Explanation of general maintenance items .....	8-2	Platinum-tipped spark plug .....	8-31
Maintenance precautions .....	8-3	Air cleaner filter .....	8-31
Engine compartment check locations .....	8-5	Cyclone pre-air cleaner .....	8-33
TB45S engine model .....	8-5	Wiper blades .....	8-34
TB45E engine model .....	8-6	Cleaning .....	8-34
TB48DE engine model (Type A) .....	8-7	Replacing .....	8-34
TB48DE engine model (Type B) .....	8-8	Brake conditions .....	8-35
ZD30DDTi engine model (Type A) .....	8-9	Checking parking brake .....	8-35
ZD30DDTi engine model (Type B) .....	8-10	Checking brake pedal .....	8-35
TD42 engine model .....	8-11	Fuses .....	8-35
TD42Ti engine model .....	8-12	Engine compartment .....	8-36
Engine cooling system .....	8-13	Passenger compartment .....	8-37
Checking engine coolant level .....	8-14	Lights .....	8-38
Changing engine coolant .....	8-14	Headlights .....	8-38
Engine oil .....	8-17	Exterior lights .....	8-38
Checking engine oil level .....	8-17	Interior lights .....	8-39
Changing engine oil .....	8-17	Light location .....	8-40
Changing engine oil filter .....	8-19	Tires and wheels .....	8-48
Protect the environment .....	8-21	Tire inflation pressure .....	8-48
Fuel filter (diesel engine model) .....	8-21	Types of tires .....	8-48
Draining water .....	8-21	Tire chains .....	8-49
Bleeding the fuel system .....	8-22	Tire rotation .....	8-50
Automatic transmission fluid .....	8-23	Tire wear and damage .....	8-50
Power steering fluid .....	8-24	Tire age .....	8-50
Brake and clutch fluid .....	8-25	Changing wheels and tires .....	8-51
Window washer fluid .....	8-26	<b>4x4</b> Tires for four-wheel drive (4WD) model... ..	8-51
Battery .....	8-27	Wheel balance .....	8-51
Vehicle battery .....	8-27	<b>4x4</b> Clutch housing .....	8-51
Remote controller battery .....	8-28	Checking water entry .....	8-51
Drive belts .....	8-30	Knuckle flange .....	8-52
		Checking water entry .....	8-52

## MAINTENANCE REQUIREMENTS

Your new NISSAN has been designed to have minimum maintenance requirements with longer service intervals to save you both time and money. However, some day-to-day and regular maintenance is essential to maintain your NISSAN's good mechanical condition, as well as its emission and engine performance.

It is the owner's responsibility to make sure that scheduled maintenance, as well as general maintenance, is performed.

As the vehicle owner, you are the only one who can ensure that your vehicle receives the proper maintenance care. You are a vital link in the maintenance chain.

### Scheduled maintenance

For your convenience, the required scheduled maintenance items are described and listed in a separate maintenance booklet. You must refer to that booklet to ensure that necessary maintenance is performed on your NISSAN at regular intervals.

### General maintenance

General maintenance includes those items which should be checked during normal day-to-day operation of the vehicle. They are essential if your vehicle is to continue to operate properly. It is your responsibility to perform these procedures regularly as prescribed.

Performing general maintenance checks require minimal mechanical skill and only a few general automotive tools.

These checks or inspections can be done by yourself, a qualified technician or, if you prefer, your NISSAN dealer.

### Where to go for service

If maintenance service is required or your vehicle appears to malfunction, have the systems checked and tuned by a NISSAN dealer.

NISSAN technicians are well-trained specialists and are kept up to date with the latest service information through technical bulletins, service tips, and in-dealership training programs. They are completely qualified to work on NISSAN's vehicles **before** they work on your vehicle, rather than after they have worked on it.

You can be confident that NISSAN dealer's service department performs the best job to meet the maintenance requirements on our vehicle — in a reliable and economic way.

## GENERAL MAINTENANCE

During the normal day-to-day operation of the vehicle, general maintenance should be performed regularly as prescribed in this section. If you detect any unusual sounds, vibrations or smell, be sure to check for the cause or have a NISSAN dealer do it promptly. In addition, you should notify a NISSAN dealer if you think that repairs are required.

When performing any checks or maintenance work, closely observe "Maintenance precautions" later in this section.

### EXPLANATION OF GENERAL MAINTENANCE ITEMS

**Additional information on the following items with "\*" is found later in this section.**

#### Outside the vehicle

The maintenance items listed here should be performed from time to time, unless otherwise specified.

**Tires\*** Check the pressure with a gauge periodically when at a service station (including the spare) and adjust to the specified pressure if necessary. Check carefully for damage, cuts or excessive wear.

**Windshield/rear wiper blades\*** Check for cracks or wear if they do not wipe properly.

**Doors and engine hood** Check that all doors,

the engine hood and back door operate properly. Also ensure that all latches lock securely. Lubricate hinges and latches if necessary. Make sure that the secondary latch keeps the hood from opening when the primary latch is released.

When driving in areas using road salt or other corrosive materials, check for lubrication frequently.

**Lights\*** Make sure that the headlights, stop lights, tail lights, turn signal lights, and other lights are all operating properly and installed securely. Also check headlight aim.

**Tire rotation\*** Tires should be rotated every 5,000 km (3,000 miles) for 4WD vehicles.

#### Inside the vehicle

The maintenance items listed below should be checked on a regular basis, such as when performing periodic maintenance, cleaning the vehicle, etc.

**Warning/indicator lights and chimes** Make sure that all warning/indicator lights and chimes are operating properly.

**Steering wheel** Check for change in the steering conditions, such as excessive free play, hard steering or strange noises.

**Seat belts** Check that all parts of the seat belt system (e.g. buckles, anchors, adjusters and

retractors) operate properly and smoothly, and are installed securely. Check the belt webbing for cuts, fraying, wear or damage.

#### Under the hood and vehicle

The maintenance items listed here should be checked periodically e.g. each time you check the engine oil or refuel.

**Window washer fluid\*** Check that there is adequate fluid in the tank.

**Engine coolant level\*** Check the coolant level when the engine is cold.

**Engine oil level\*** Check the oil level after parking the vehicle on a level spot and turning off the engine.

**Brake and clutch fluid level\*** Make sure that the brake and clutch fluid level is between the MAX and MIN lines on the reservoir.

**Battery\*** Check the fluid level in each cell. It should be between the MAX and MIN lines.

## MAINTENANCE PRECAUTIONS

When performing any inspection or maintenance work on your vehicle, always take care to prevent serious accidental injury to yourself or damage to the vehicle. The following are general precautions which should be closely observed.

- **Park the vehicle on a level surface, apply the parking brake securely and block the wheels to prevent the vehicle from moving. For a manual transmission, move the shift lever to the N (Neutral) position. For an automatic transmission, move the selector lever to the P (Park) position.**
- **Be sure the ignition key is "OFF" or "LOCK" when performing any replacement or repair.**
- **Do not work under the engine hood while it is hot. Always turn off the engine and wait until it cools down.**
- **If you must work with the engine running, keep your hands, clothing, hair and tools away from moving fans, belts and any other moving parts.**
- **It is advisable to remove ties and any jewelry, such as rings, watches, etc. before working on your vehicle.**
- **If you must run the engine in an enclosed space such as a garage, be sure**

there is proper ventilation for exhaust gases.

- **Never get under the vehicle while it is supported only by a jack. If it is necessary to work under the vehicle, support it with safety stands.**
- **Keep smoking materials, flame and sparks away from fuel and battery.**
- **Never connect or disconnect either the battery or any transistorized component connector while the ignition is on.**
- **On gasoline engine models with the electronic fuel injection (Multiport fuel injection) system, the fuel filter or fuel lines should be serviced by a NISSAN dealer because the fuel lines are under high pressure even when the engine is off.**
- **Failure to follow these or other common sense guidelines may lead to serious injury or vehicle damage.**
- **Improperly disposed motor oil and/or other vehicle fluids can hurt the environment. Always conform to local regulations for disposal of vehicle fluid.**
- **Avoid direct contact with used engine oil.**

This "8. Maintenance and do-it-yourself" section gives instructions regarding only those items which are relatively easy for an owner to perform.

You should be aware that incomplete or improper servicing may result in operating difficulties or excessive emissions, and could affect your warranty coverage. **If in doubt about any servicing, have it done by a NISSAN dealer.**

## ENGINE COMPARTMENT CHECK LOCATIONS

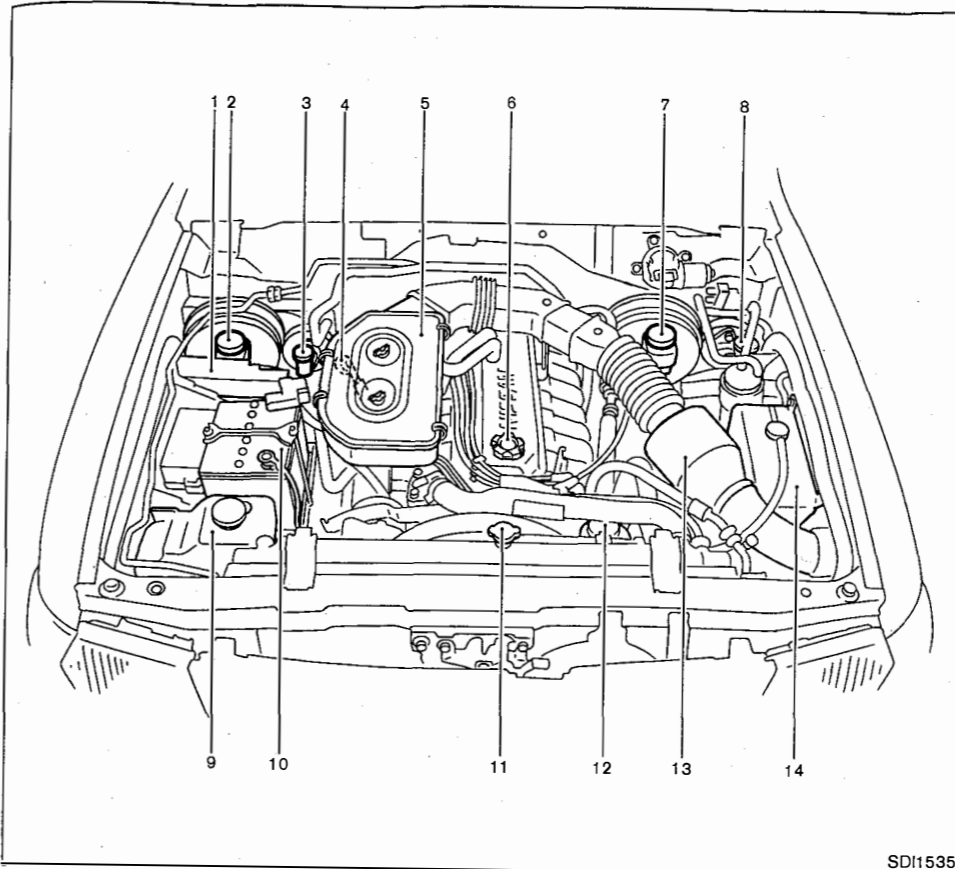

SD11535

### TB45S ENGINE MODEL

1. Fuse box
2. Brake fluid reservoir — RHD models
3. Clutch fluid reservoir (M/T) — RHD models
4. Engine oil dipstick
5. Air cleaner
6. Engine oil filler cap
7. Brake fluid reservoir — LHD models
8. Clutch fluid reservoir (M/T) — LHD models
9. Windshield washer tank
10. Battery
11. Radiator cap
12. Power steering fluid reservoir
13. Air cleaner cyclone (if so equipped)
14. Engine coolant reservoir

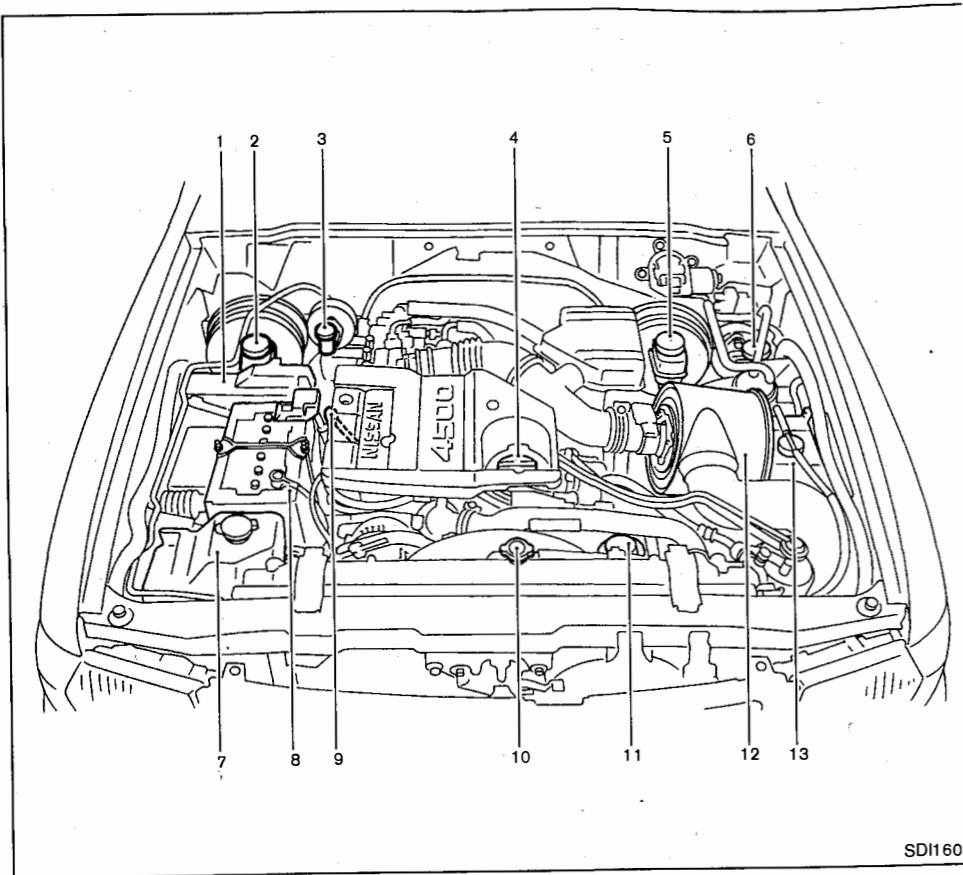

### TB45E ENGINE MODEL

1. Fuse box
2. Brake fluid reservoir — RHD models
3. Clutch fluid reservoir (M/T) — RHD models
4. Engine oil filler cap
5. Brake fluid reservoir — LHD models
6. Clutch fluid reservoir (M/T) — LHD models
7. Window washer fluid reservoir
8. Battery
9. Engine oil dipstick
10. Radiator cap
11. Power steering fluid reservoir
12. Air cleaner
13. Engine coolant reservoir

SDI1605

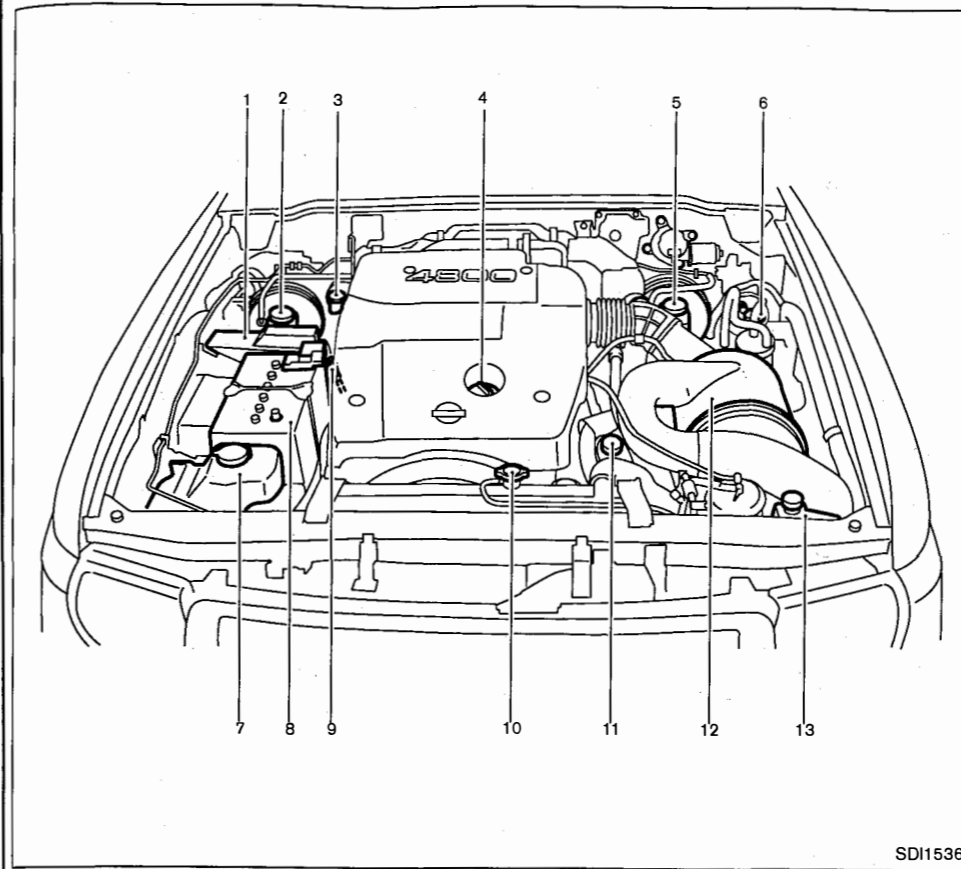

### TB48DE ENGINE MODEL (Type A)

1. Fuse box
2. Brake fluid reservoir — RHD models
3. Clutch fluid reservoir (M/T) — RHD models
4. Engine oil filler cap
5. Brake fluid reservoir — LHD models
6. Clutch fluid reservoir (M/T) — LHD models
7. Window washer fluid reservoir
8. Battery
9. Engine oil dipstick
10. Radiator cap
11. Power steering fluid reservoir
12. Air cleaner
13. Engine coolant reservoir

SDI1536

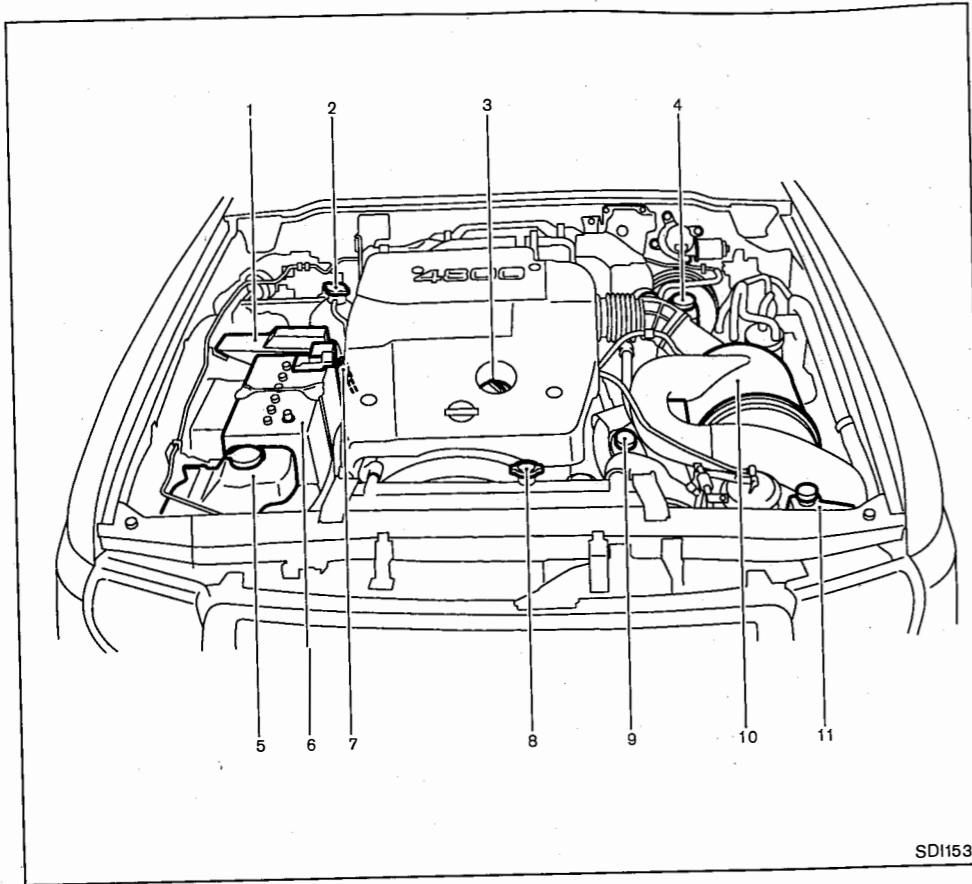

### TB48DE ENGINE MODEL (Type B)

1. Fuse box
2. Radiator cap (with pressure valve)
3. Engine oil filler cap
4. Brake fluid reservoir
5. Window washer fluid reservoir
6. Battery
7. Engine oil dipstick
8. Radiator cap (without pressure valve)
9. Power steering fluid reservoir
10. Air cleaner
11. Engine coolant reservoir

SDI1537

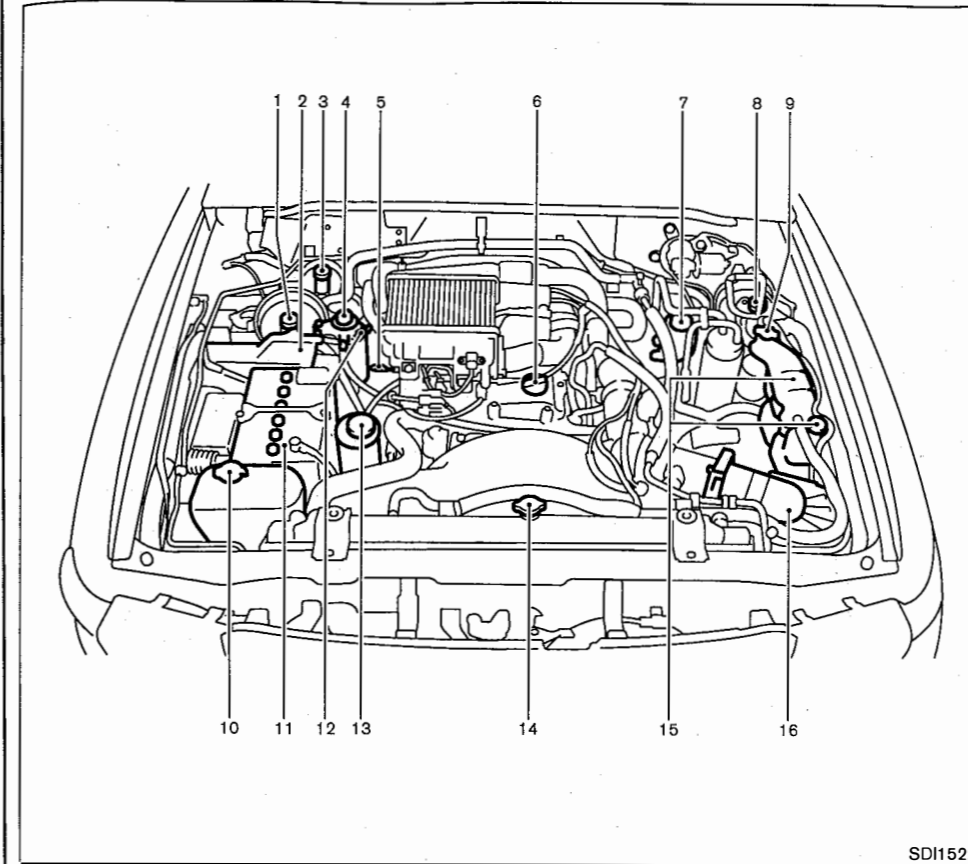

### ZD30DDTi ENGINE MODEL (Type A)

1. Brake fluid reservoir — RHD models
2. Fuse box
3. Clutch fluid reservoir (M/T) — RHD models
4. Fuel filter
5. Engine oil dipstick
6. Engine oil filler cap
7. Brake fluid reservoir — LHD models
8. Clutch fluid reservoir (M/T) — LHD models
9. Radiator cap (with pressure valve)
10. Window washer fluid reservoir
11. Battery\*
12. Automatic transmission fluid dipstick (A/T)
13. Power steering fluid reservoir
14. Radiator cap (without pressure valve)
15. Engine coolant reservoir
16. Air cleaner

\* Some models have another battery on the opposite side.

SDI1522

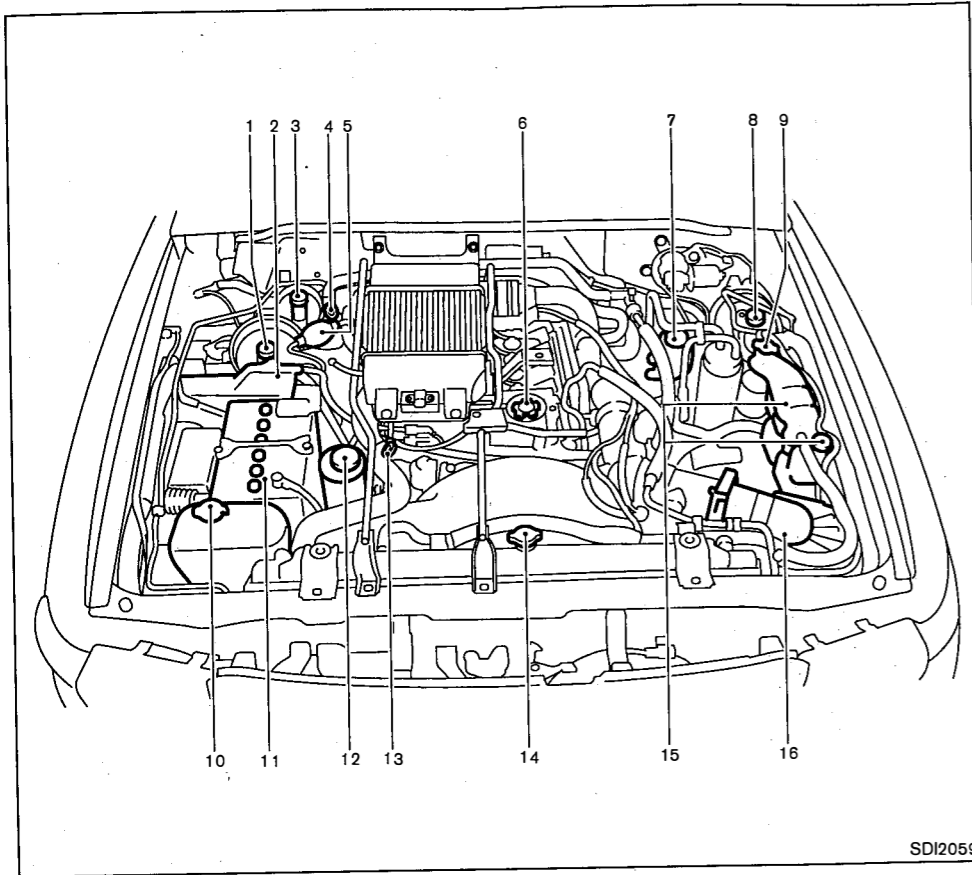

### ZD30DDTi ENGINE MODEL (Type B)

1. Brake fluid reservoir — RHD models
2. Fuse box
3. Clutch fluid reservoir (M/T) — RHD models
4. Automatic transmission fluid dipstick (A/T)
5. Fuel filter (priming pump)
6. Engine oil filler cap
7. Brake fluid reservoir — LHD models
8. Clutch fluid reservoir (M/T) — LHD models
9. Radiator cap (with pressure valve)
10. Window washer fluid reservoir
11. Battery\*
12. Power steering fluid reservoir
13. Engine oil dipstick
14. Radiator cap (without pressure valve)
15. Engine coolant reservoir
16. Air cleaner

\* Some models have another battery on the opposite side.

SDI2059

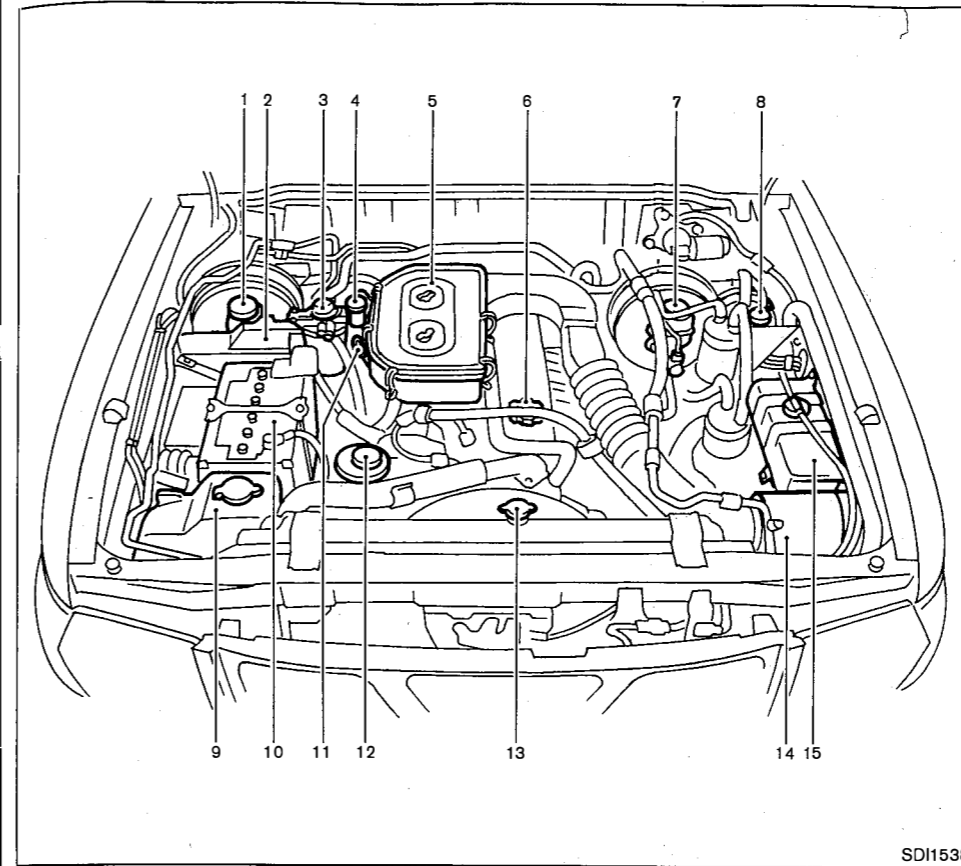

### TD42 ENGINE MODEL

1. Brake fluid reservoir — RHD models
2. Fuse box
3. Fuel filter
4. Clutch fluid reservoir (M/T) — RHD models
5. Air cleaner
6. Engine oil filler cap
7. Brake fluid reservoir — LHD models
8. Clutch fluid reservoir (M/T) — LHD models
9. Window washer fluid reservoir
10. Battery\*
11. Engine oil dipstick
12. Power steering fluid reservoir
13. Radiator cap
14. Cyclone air cleaner
15. Engine coolant reservoir

\* Some models have another battery on the opposite side.

SDI1538



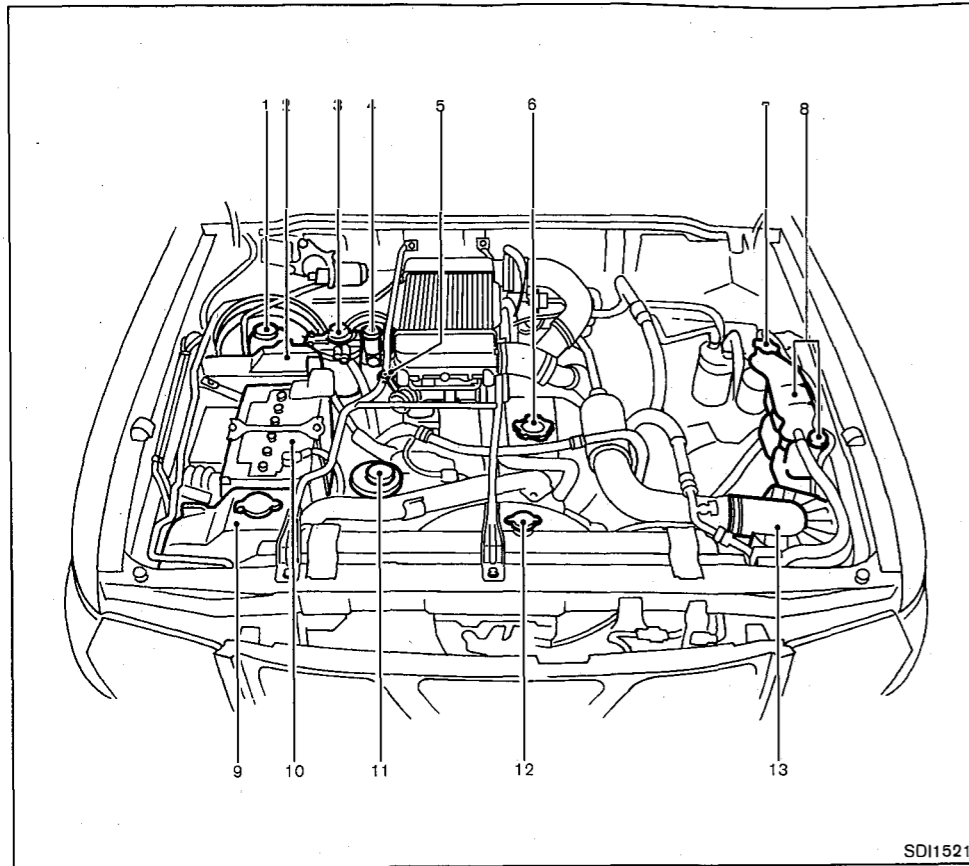

### TD42Ti ENGINE MODEL

1. Brake fluid reservoir
2. Fuse box
3. Fuel filter
4. Clutch fluid reservoir (M/T)
5. Engine oil dipstick
6. Engine oil filler cap
7. Radiator cap (with pressure valve)
8. Engine coolant reservoir
9. Window washer fluid reservoir
10. Battery
11. Power steering fluid reservoir
12. Radiator cap (without pressure valve)
13. Air cleaner

## ENGINE COOLING SYSTEM

The engine cooling system is filled at the factory with a high-quality, year-round and extended life engine coolant. The high quality engine coolant contains the specific solutions effective for the anti-corrosion and the anti-freeze function. Therefore, additional cooling system additives are not necessary.

### CAUTION:

- **For Europe**  
When adding or replacing coolant, be sure to use only **Genuine NISSAN Engine Coolant or equivalent in its quality. Genuine NISSAN Engine Coolant is pre-mixed (mixture ratio 50%) type coolant.**
- **Except for Europe**  
When adding or replacing coolant, be sure to use only a **Genuine NISSAN Engine Coolant or equivalent in its quality with the proper mixture ratio. Examples are shown below:**

Outside temperature down to		Composition	
°C	°F	Engine coolant (concentrated)	Demineralized water or distilled water
-15	5	30%	70%
-35	-30	50%	50%

The use of other types of engine coolant may damage your cooling system.

The radiator is equipped with a pressure cap. Use a NISSAN genuine cap or its equivalent when replacement is required.

### ⚠ WARNING:

- **Never remove the radiator cap when the engine is hot. Serious burns could be caused by high pressure fluid escaping from the radiator. Wait until the engine and radiator cool down. See precautions in "If your vehicle overheats" found in the "6. In case of emergency" section.**
- **Engine coolant is poisonous and should be stored carefully in marked containers out of the reach of children.**

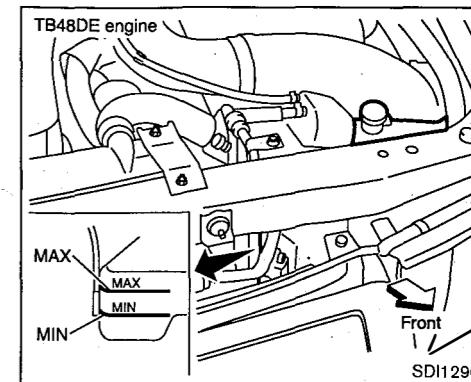
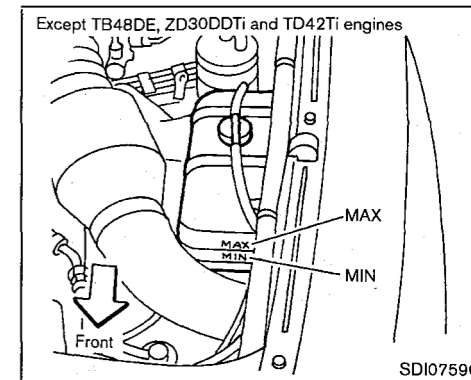

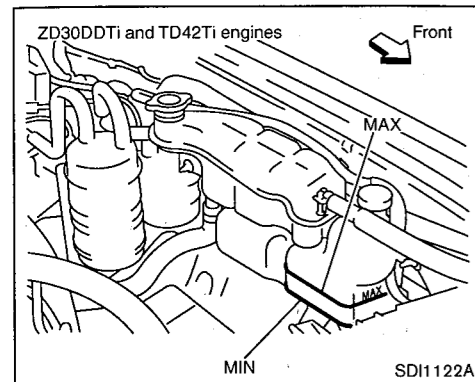

### CHECKING ENGINE COOLANT LEVEL

With coolant reservoir

Check the coolant level in the reservoir tank when the engine is cold. If the coolant level is below MIN, add coolant to the MAX level. If the reservoir tank is empty, check the coolant level in the radiator **when the engine is cold**. If there is insufficient coolant in the radiator, fill the radiator (upper engine coolant reservoir on ZD30DDTi, TD42Ti and TB48DE — Type B engines) with NISSAN Genuine Engine Coolant or equivalent up to the filler opening and also add it to the reservoir tank up to the MAX level.

### CAUTION:

If the cooling system frequently requires coolant, have it checked by a NISSAN dealer.

### CHANGING ENGINE COOLANT

- Major cooling system repairs should be performed by a NISSAN dealer. The service procedures can be found in the appropriate NISSAN Service Manual.
- Improper servicing can result in reduced heater performance and engine overheating.

### WARNING:

- To avoid the danger of being scalded, never change the coolant when the engine is hot.
- Never remove the radiator cap when the engine is hot. Serious burns could be caused by high pressure fluid escaping from the radiator.

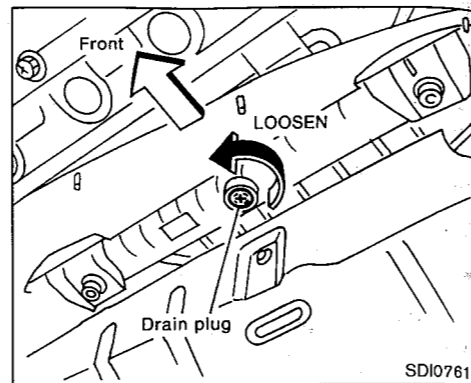

1. Move the heater or air conditioner temperature control to the maximum hot position.

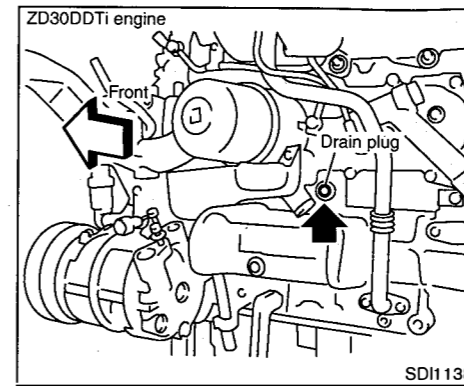
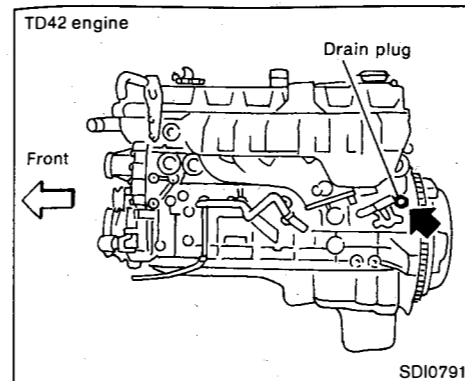
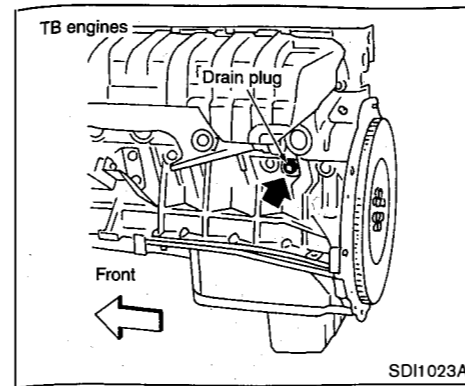

2. Open the radiator drain plug and the drain plug on the engine block.

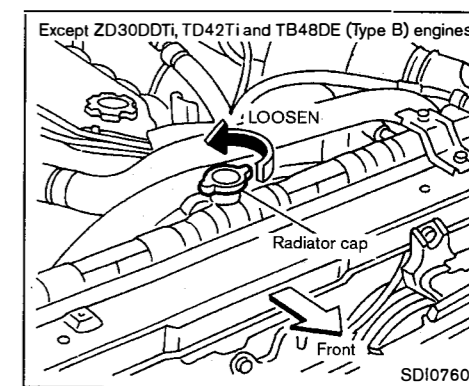

3. **Except ZD30DDTi, TD42Ti and TB48DE (Type B) engines:**  
Open the radiator cap.

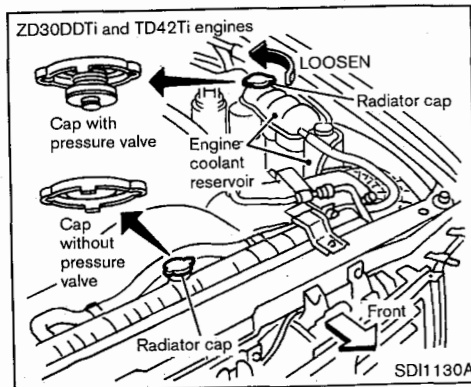

**For ZD30DDTi, TD42Ti and TB48DE (Type B) engines:**

Open the radiator cap on the engine coolant reservoir.

Two types of caps are used in the cooling system for these engines as shown. Use a NISSAN genuine cap or its equivalent when replacement is required.

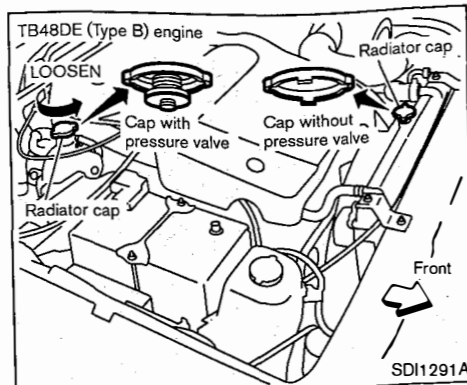

**WARNING:**

Make sure to install the cap with the pressure valve on the coolant reservoir tank. If the two types of caps are interchanged, overheating may occur.

4. Flush the cooling system by running fresh water through the radiator.
5. Securely close the radiator and engine block drain plugs.
6. See "Recommended fuel/lubricants and capacities" in the "9. Technical information" section for cooling system capacity. Fill the radiator slowly with the proper mixture of coolant and water. Fill the reservoir tank up to the MAX level. Then install the radiator cap.
7. Start the engine and warm it up until it reaches normal operating temperature. Then race the engine 2 or 3 times under no load. Watch the coolant temperature gauge for signs of overheating.
8. Stop the engine. After it completely cools down, refill the radiator up to the filler opening. Fill the reservoir tank up to the MAX level.
9. Check the drain plugs for any sign of leakage.

**ENGINE OIL**

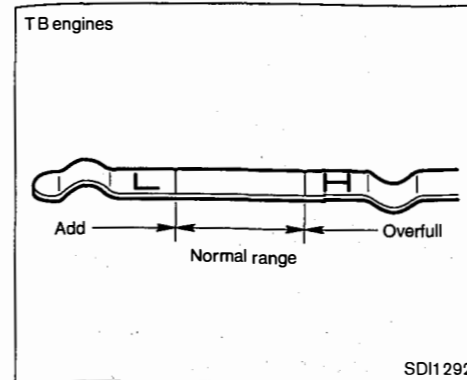

**CHECKING ENGINE OIL LEVEL**

1. Run the engine until it reaches operating temperature.
2. Turn off the engine. **Wait a few minutes for the oil to drain back into the oil pan.**
3. Remove the dipstick and wipe it clean. (See "Engine compartment check locations" earlier in this section for the location of the engine oil dipstick.) Reinsert it all the way.
4. Remove the dipstick again and check the oil level. It should be between the H and L marks (Gasoline engine) or between the cutout edges (Diesel engine). If the oil level is below the L mark/Low level, remove the oil filler cap

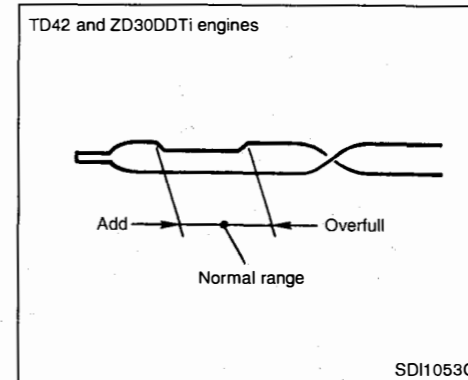

and pour recommended oil through the opening. **Do not overfill.**

5. Recheck oil level with dipstick.

**CAUTION:**

- Oil level should be checked regularly. Operating with insufficient amount of oil can damage the engine, and such damage is not covered by warranty.
- It is normal to add some oil between oil maintenance intervals or during the break-in period, depending on the severity of operating conditions.
- NISSAN recommends checking the oil level every 7,500 km (4,700 miles). (ZD30DDTi engine)

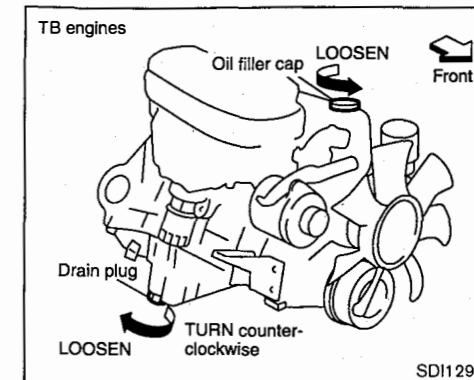

**CHANGING ENGINE OIL**

1. Run the engine until it reaches operating temperature, and then turn it off.
2. Place a large drain pan under the drain plug.
3. Remove the oil filler cap.
4. Remove the drain plug with a wrench and completely drain the oil.

If the oil filter is to be changed, remove and replace it at this time. See "Changing engine oil filter".

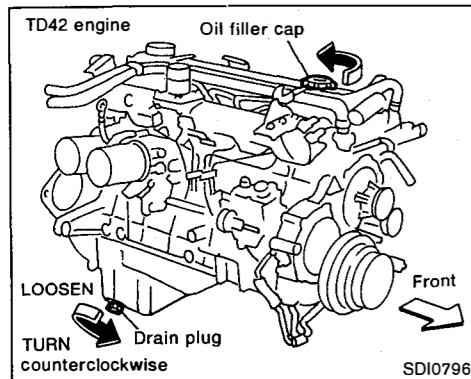

**WARNING:**

Be careful not to burn yourself, as the engine oil is hot.

**CAUTION:**

Waste oil must be disposed of properly. Check your local regulations.

- Clean and re-install the drain plug and a new washer. Securely tighten the drain plug with a wrench.

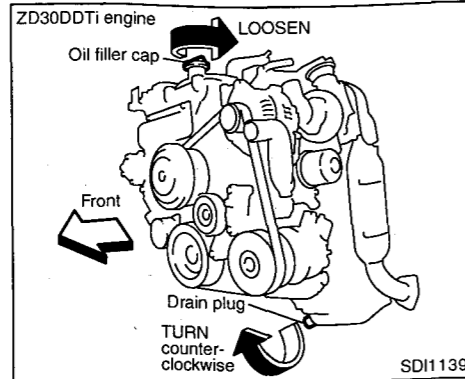

**Drain plug tightening torque:**

Except for ZD30DDTi engine:

29 to 39 N·m  
(3.0 to 4.0 kg-m,  
22 to 29 ft-lb)

For ZD30DDTi engine:

54 to 59 N·m  
(5.5 to 6.0 kg-m,  
40 to 43 ft-lb)

Do not use excessive force.

- Refill engine with recommended oil and install the cap securely.

See "Recommended fuel/lubricants and ca-

pacities" in the "9. Technical information" section for refill capacity.

- Start the engine.

Check for leakage around the drain plug. Correct as required.

- Turn the engine off and wait several minutes. Check the oil level with the dipstick. Add engine oil if necessary.



**WARNING:**

- Prolonged and repeated contact with used engine oil may cause skin cancer.
- Try to avoid direct skin contact with used oil. If skin contact is made, wash thoroughly with soap or hand cleaner as soon as possible.
- Keep used engine oil out of reach of children.

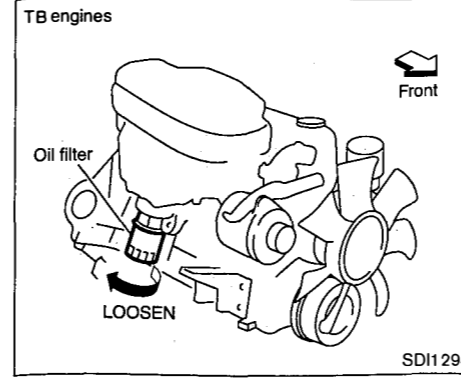

**CHANGING ENGINE OIL FILTER**

Except for ZD30DDTi engine

A used oil filter should be disposed of at a rubbish tip having proper facilities. We recommend having your oil filter changed by a NISSAN dealer.

- Turn the engine off.
- Loosen the oil filter with an oil filter wrench. (Depending on the engine model, a special cap type wrench may be required. See a NISSAN dealer if in doubt.) Remove the oil filter by turning it by hand.

Be careful not to burn yourself, as the engine oil may be hot.

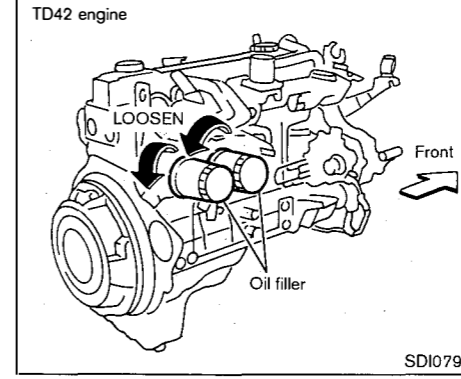

- Wipe the engine oil filter mounting surface with a clean rag.

Be sure to remove any old rubber gasket remaining on the mounting surface of the engine.

- Coat the rubber gasket on the new filter with engine oil.
- Screw in the oil filter until a slight resistance is felt, then tighten additionally more than 2/3 turn.
- Start the engine and check for leakage around the oil filter. Correct as required.
- Turn the engine off and wait several minutes. Check the oil level. Add engine oil if necessary.

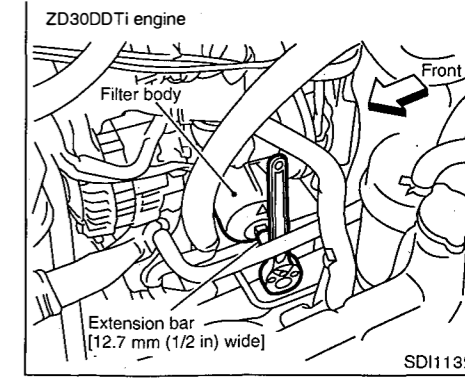

For ZD30DDTi engine (filter element)

A used oil filter should be disposed of at a rubbish tip having proper facilities. We recommend having your oil filter changed by a NISSAN dealer.

- Turn the engine off.
- Insert an extension bar 12.7-mm (1/2 inch) wide and the ratchet handle into the square hole in the filter body. Loosen about 4 turns.

Be careful not to burn yourself, as the engine oil may be hot.

- Drain oil by facing the ▲ mark upward on the lateral side of the filter body.

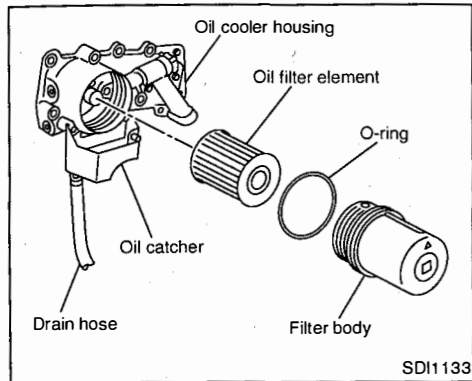

SD11133

Catch the oil drained from the drain hose in a container.

- About 500 ml (17.6 Imp fl oz) of oil will drain in about 3 minutes.
  - Oil is drained through the drain hose from the oil catcher to the underside of the vehicle.
4. Remove the filter body and remove the oil filter element.
- **If oil is spilled on the engine or the vehicle, thoroughly wipe it off.**
  - **Wipe off the oil remaining in the oil catcher.**  
(If there is oil leakage, it will be difficult to

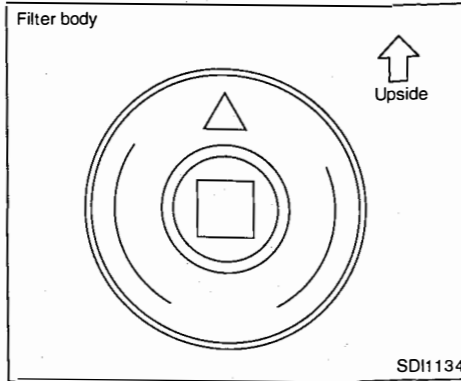

SD11134

judge whether the oil leaks from the engine or oil catcher.)

5. Remove the O-ring from the filter body. Push the O-ring toward one side with your hand and pinch the portion separated from the filter body.
- Do not use a wire or screwdriver as this could damage the filter body.**
6. Remove foreign materials thoroughly from the inside of the filter body and the O-ring mounting portion (body side and oil cooler side).
7. Install the oil filter element and O-ring to the filter body.

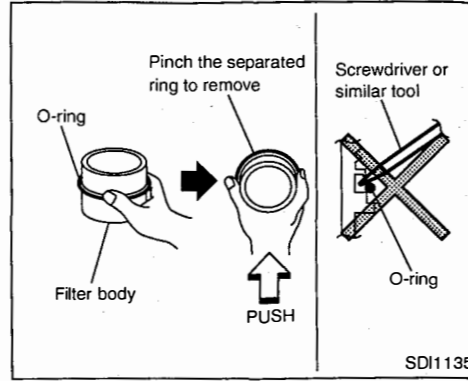

SD11135

- Securely fit the oil filter element into the filter body.

8. Install the filter body.

**Tightening torque:**  
**19.6 to 24.5 N·m**  
**(2.0 to 2.5 kg-m, 14 to 18 ft-lb)**

9. After warming up the engine, make sure there is no oil leakage.

## PROTECT THE ENVIRONMENT

It is illegal to pollute drains, water courses and soil. Use authorized waste collection facilities, including civic amenity sites and garages providing facilities for disposal of used oil and used oil filters. If in doubt, contact your local authority for advice on disposal.

**The regulations concerning the pollution of the environment will vary from country to country.**

## FUEL FILTER (diesel engine model) DRAINING WATER

Drain water in the fuel filter according to the maintenance log shown in a separate maintenance booklet.

### Warning light (if so equipped)

If the water in fuel filter warning light "☹" (and a chime — if so equipped) or the malfunction indicator light "⚠" illuminates while the engine is running, it may indicate that you need to immediately drain the water from the fuel filter.

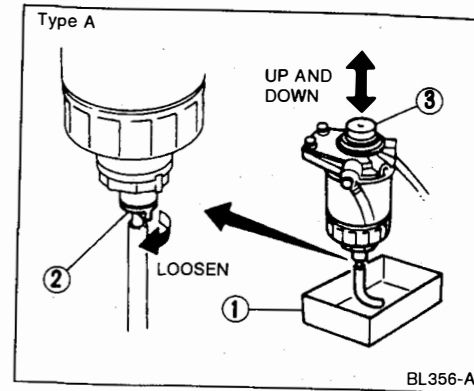

BL356-A

### Type A

1. Place a container (1) under the fuel filter.
2. Loosen the drain valve (2) 4 to 5 turns to drain the water. To avoid dropping it, do not loosen the drain valve too much. If water does not drain properly, move the priming pump (3) up and down.
3. After the water has been completely drained, close the drain valve (2).
4. Bleed any air from the fuel system. (See "Bleeding the fuel system".)

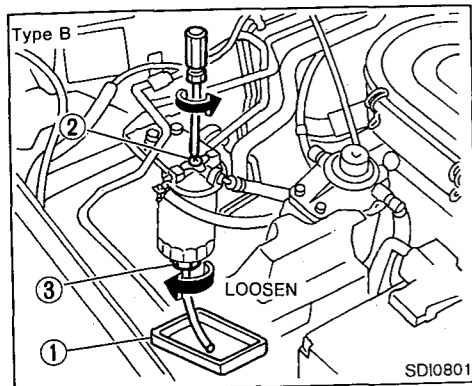

#### Type B

1. Place a container ① under the drain valve.
2. Loosen the drain support screw ② and drain valve ③ 4 to 5 turns to drain the water. To avoid dropping it, do not loosen the drain valve too much.
3. After the water has been completely drained, close the drain valve ③ and drain support screw ②.
4. Bleed any air from the fuel system. (Refer to "Bleeding the fuel system".)

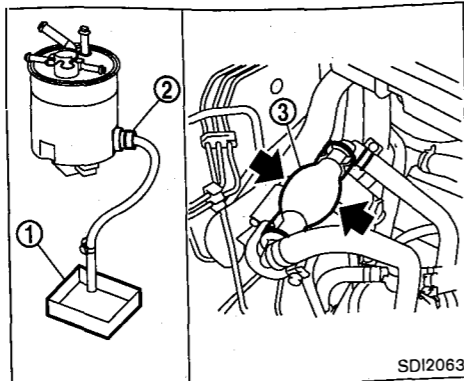

#### Type C

1. Place a container ① under the fuel filter.
2. Loosen the drain valve ② 4 to 5 turns (counterclockwise) to drain the water. To avoid dropping it, do not loosen the drain valve too much. If water does not drain properly, operate the priming pump ③.
3. After the water has been completely drained, close the drain valve ②.
4. Bleed any air from the fuel system. (See "Bleeding the fuel system".)

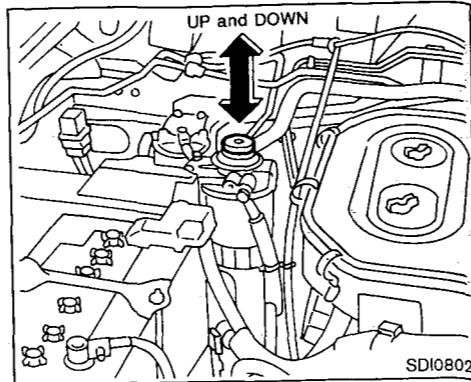

#### BLEEDING THE FUEL SYSTEM

##### Types A and B

Bleed air out of the fuel system after refilling an empty fuel tank by the following action:

1. Move the priming pump up and down until a resistance occurs, then stop the pumping.
2. Crank the engine until the engine starts. Do not crank the engine for more than 30 seconds.
3. If the engine does not start, stop cranking and repeat step 1 above.
4. If the engine does not operate smoothly after it has started, race it two or three times.

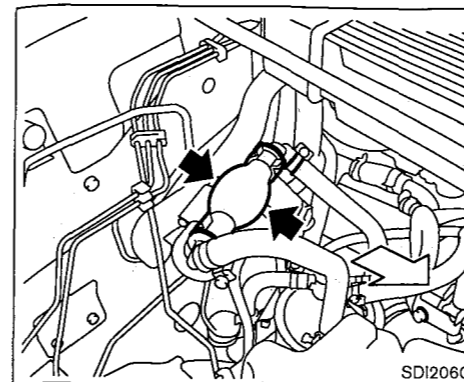

##### Type C

Bleed air out of the fuel system after refilling an empty fuel tank by the following action:

1. Squeeze the priming pump several times until there is a sudden resistance felt in the pressure, then stop.
2. Crank the engine until it starts. Do not crank the engine for more than 30 seconds.
3. If the engine does not start, stop cranking and repeat step 1 above.
4. If the engine does not operate smoothly after it has started, race it two or three times.

#### AUTOMATIC TRANSMISSION FLUID

For 5-speed transmission models

Contact a NISSAN dealer if checking or replacement is required.

##### CAUTION:

- Use only Genuine NISSAN Matic J ATF. Do not mix with other fluids.
- Using automatic transmission fluid other than Genuine NISSAN Matic J ATF will cause deterioration in driveability and automatic transmission durability, and may damage the automatic transmission, which is not covered by the warranty.

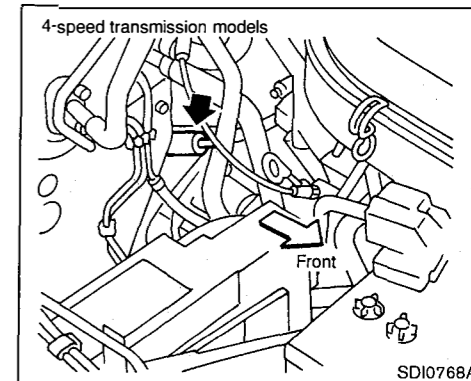

For 4-speed transmission models

##### ⚠ WARNING:

- When engine is running, keep hands and clothing away from any moving parts such as fan drive belt.
- Automatic transmission fluid is poisonous and should be stored carefully in marked containers out of the reach of children.

The fluid level should be checked using the "HOT" range on the dipstick at fluid temperatures between 50 and 80°C (122 and 176°F) after the vehicle has been driven approximately 5 minutes in urban areas after the engine is

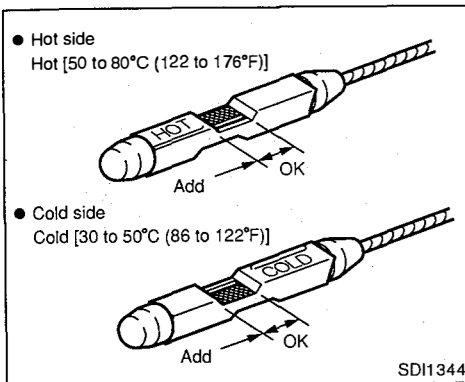

ately. You should wait until the fluid has cooled down (about 30 minutes).

- Remove the dipstick and wipe it clean with lint-free paper.
- Re-insert the dipstick into the charging pipe as far as it will go.
- Remove the dipstick and note the reading.

If the level is on the low side of either range, add fluid to the charging pipe.

**Do not overfill.**

**CAUTION:**

**Use Genuine NISSAN Matic D ATF or equivalent (if available).**

warmed up. The level can be checked at fluid temperatures between 30 and 50°C (86 and 122°F) using the "COLD" range on the dipstick for reference, after the engine is warmed up but before driving. However, the fluid level must be rechecked using the "HOT" range.

- Park the vehicle on a level surface and set the parking brake.
- Start the engine and then move the selector lever through each gear range, ending in "P".
- Check the fluid level with the engine idling.

**If the vehicle has been driven for a long time at high speeds, or in city traffic in hot weather, or if it is being used to pull a trailer, the fluid level cannot be read accu-**

## POWER STEERING FLUID

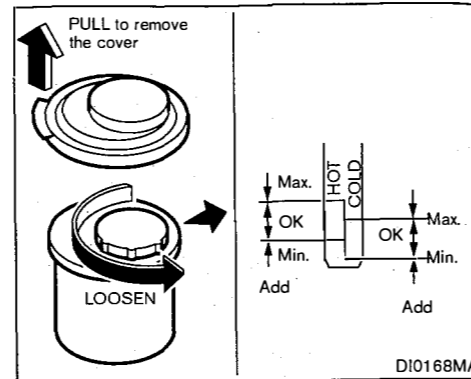

Check the fluid level.

The fluid level should be checked using the "HOT" range on the dipstick at fluid temperatures of 50 to 80°C (122 to 176°F) or using the "COLD" range on the dipstick at fluid temperatures of 0 to 30°C (32 to 86°F).

- **Do not overfill.**
- **The recommended fluid is Genuine NISSAN PSF or equivalent.**

**WARNING:**

**Power steering fluid is poisonous and should be stored carefully in marked containers out of the reach of children.**

## BRAKE AND CLUTCH FLUID

**WARNING:**

- **Use only new fluid from a sealed container. Old, inferior, or contaminated fluid may damage the brake and clutch systems. The use of improper fluids can damage the brake system and affect the vehicle's stopping ability.**
- **Clean the filler cap before removing.**
- **Brake fluid is poisonous and should be stored carefully in marked containers out of the reach of children.**

**CAUTION:**

**Do not spill the brake fluid on painted surfaces. This will damage the paint. If brake fluid is spilled, wash it off with plenty of water immediately.**

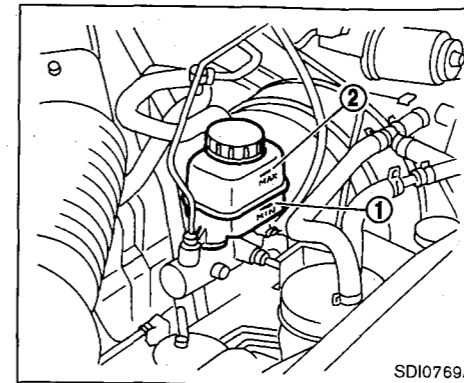

Brake fluid

Check the fluid level in each reservoir. If the fluid level is below the MIN. line ①, or the brake warning light comes on (for the brake fluid), add fluid\* up to the MAX. line ②. If fluid must be added frequently, the system should be thoroughly checked by a NISSAN dealer.

\* For Europe: DOT3 or DOT4 (U.S. FMVSS No. 116)\*1

\*1: Never mix DOT3 and DOT4. (DOT3 is filled at factory.)

Except for Europe: DOT3 (U.S. FMVSS No. 116)

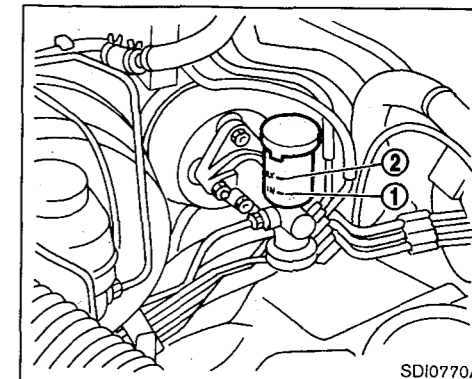

Clutch fluid

## WINDOW WASHER FLUID

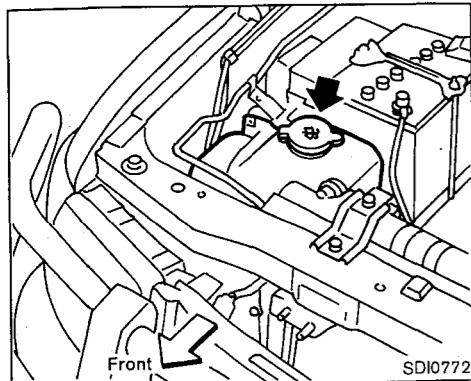

Check the fluid level in the reservoir tank and add fluid if necessary. Add a washer solvent to the washer fluid for better cleaning. In the winter season, add a windshield washer anti-freeze. Follow the manufacturer's instructions for the mixture ratio.

### CAUTION:

**Do not substitute engine anti-freeze coolant for window washer solution. This may result in damage to the paint.**



### WARNING:

**Anti-freeze is poisonous and should be stored carefully in marked containers out of the reach of children.**

## BATTERY

Caution symbols for battery			⚠ WARNING
①		No smoking, No exposed flames, No sparks	Never smoke around battery. Never expose battery to open flames or electrical sparks.
②		Shield eyes	Handle the battery cautiously. Always wear eye protection glasses to protect against explosion or battery acid.
③		Keep away from children	Never allow children to handle battery. Keep the battery out of the reach of children.
④		Battery acid	Do not allow battery fluid to contact your skin, eyes, fabrics, or painted surfaces. After handling the battery or battery cap, immediately wash your hands thoroughly. If the battery fluid gets into your eyes, or onto your skin or clothing, flush with water immediately for at least 15 minutes and seek medical attention. Battery fluid is acid. If the battery fluid gets into your eyes or onto your skin, it could cause loss of your eyesight or burns.
⑤		Note operating instructions	Before handling the battery, read this instruction carefully to ensure correct and safe handling.
⑥		Explosive gas	Hydrogen gas, generated by battery fluid, is explosive.

SDI1573

## VEHICLE BATTERY

- Keep the battery surface clean and dry. Any corrosion should be washed off with a solution of baking soda and water.
- Make certain the terminal connections are clean and securely tightened.
- If the vehicle is not to be used for 30 days or

longer, disconnect the "—" negative battery terminal cable to prevent discharge.



### WARNING:

**Do not operate the vehicle if the fluid in the battery is low. Low battery fluid can cause a higher load on the battery which can generate heat, reduce battery life, and in**

**some cases lead to an explosion.**



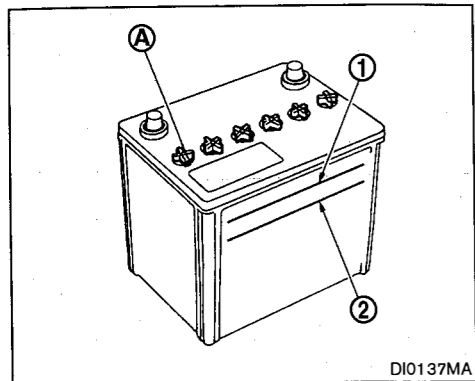

DI0137MA

Check the fluid level in each cell. It should be between the UPPER LEVEL ① and LOWER LEVEL ② lines.

If it is necessary to add fluid, add only distilled water to bring the level to the indicator in each filler opening. **Do not overfill.**

1. Remove the cell plugs (A) using a suitable tool.
2. Add distilled water up to the UPPER LEVEL ① line.

If the side of the battery is not clear, check the distilled water level by looking directly above the cell, as illustrated.

3. Tighten cell plugs.

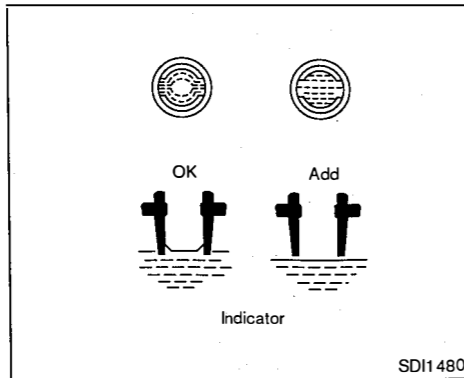

SDI1480

**CAUTION:**

**Do not overfill battery cells. Excessive electrolyte may leak out of the battery during charging, and cause paint damage.**

**Jump starting**

If jump starting is necessary, see the "In case of emergency" section. If the engine does not start by jump starting, the battery may have to be replaced. Contact a NISSAN dealer.

**REMOTE CONTROLLER BATTERY**

**Battery replacement**

**CAUTION:**

- Be careful not to allow children to swallow the battery and removed parts.
- An improperly disposed battery can harm the environment. Always confirm local regulations for battery disposal.

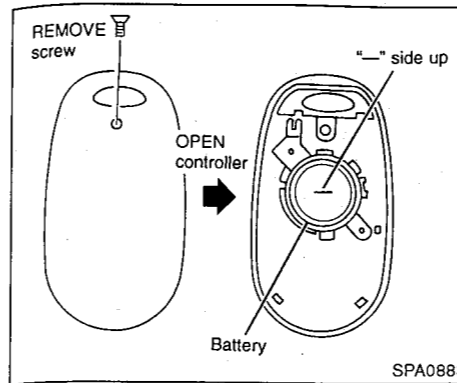

SPA0883

**Type A:**

To replace the battery:

1. Remove the screw and open the lid.
2. Replace the battery with a new one. Insert the battery as illustrated above.

Recommended battery: CR1620 or equivalent.

3. Close the lid securely and install the screw.
4. Push the LOCK button, then the UNLOCK button two or three times to check the multi-remote controller operation.

See a NISSAN dealer if you need any assistance for replacement.

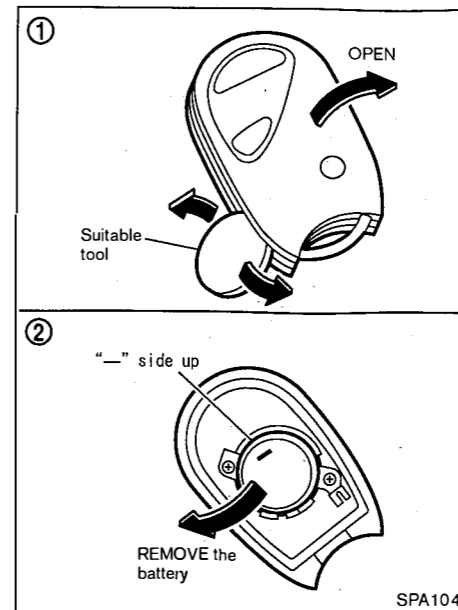

SPA1046

**Type B:**

To replace the battery:

1. Open the lid using a suitable tool.
2. Replace the battery with a new one. Recommended battery: CR2025 or equivalent
3. Close the lid securely.

4. Push the remote controller button two or three times to check its operation.

See a NISSAN dealer if you need any assistance for replacement.

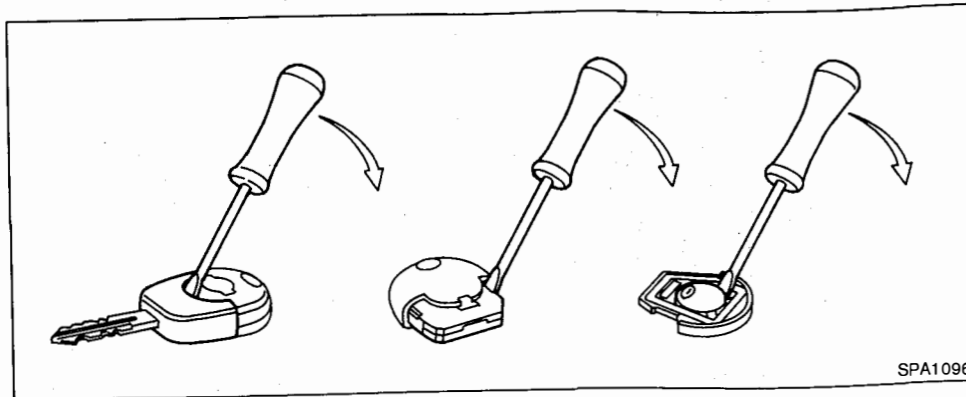

#### Type C:

To replace the battery:

1. Remove the old battery.
2. Fit the new battery, and carefully close the case.

Recommended battery: CR2025 or equivalent

**Make sure that the ⊕ side faces the bottom case.**

3. Push the LOCK button, then the UNLOCK button two or three times to check the remote controller operation.

See a NISSAN dealer if you need any assistance for replacement.

## DRIVE BELTS

Be sure the ignition switch is "OFF".

1. Visually inspect each belt for signs of unusual wear, cuts, fraying or looseness. If the belt is in poor condition or loose, have it replaced or adjusted by a NISSAN dealer.
2. Have the belts checked regularly for condition and tension.

## SPARK PLUGS (gasoline engine model)

### REPLACING SPARK PLUGS

If replacement is required, see a NISSAN dealer for servicing.



**WARNING:**  
Be sure the engine and ignition switch are off and that the parking brake is engaged securely.

#### CAUTION:

Be sure to use the correct wrench to remove the plugs. An incorrect wrench can cause damage.

Replace spark plugs according to the maintenance log shown in a separate maintenance booklet.

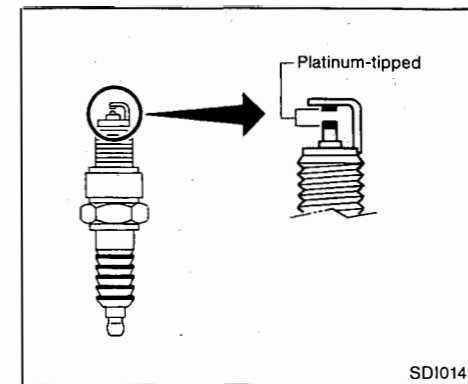

### PLATINUM-TIPPED SPARK PLUG (if so equipped)

It is not necessary to replace the platinum-tipped spark plugs as frequently as the conventional type spark plugs since they will last much longer. Follow the maintenance log but, do not reuse them by cleaning or regapping.

**Always replace with recommended platinum-tipped spark plugs.**

## AIR CLEANER FILTER



**WARNING:**  
Operating the engine with the air cleaner filter off can cause you or others to be burned. The air cleaner filter not only cleans the air, it stops flame if the engine backfires. If it is not there, and the engine backfires, you could be burned. Do not drive with it off, and be careful working on the engine when the air cleaner filter is off.

### Viscous paper type

The filter element should not be cleaned and reused as it is given a special treatment. We recommend it be replaced according to the maintenance log shown in a separate maintenance booklet. When replacing the filter, wipe the inside of the air cleaner housing and the cover with a damp cloth.

### Dry paper type

Check the filter element to see if it is dirty. If it is dirty, shake the element to remove dust. We recommend it be cleaned or replaced according to the maintenance log shown in a separate maintenance booklet. When cleaning or replacing the filter, wipe the inside of the air cleaner housing and the cover with a damp cloth.

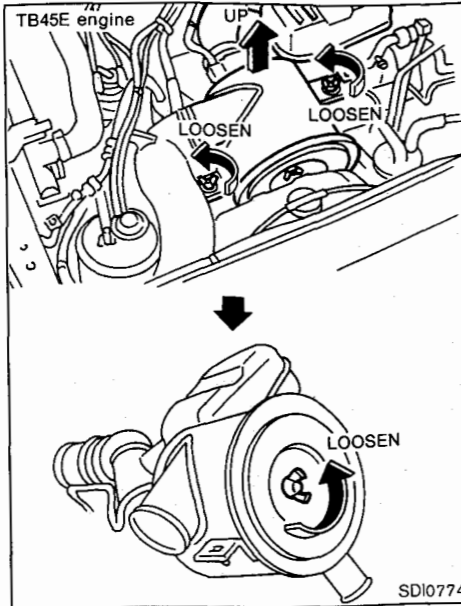
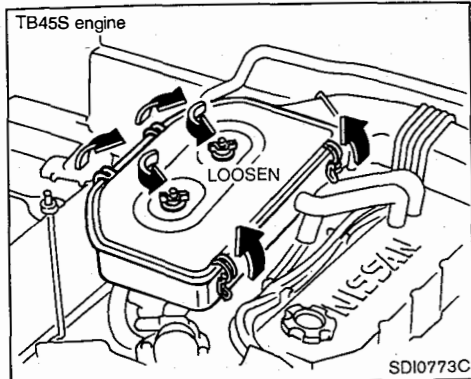

Tighten the nuts hand. Do not use any tools.

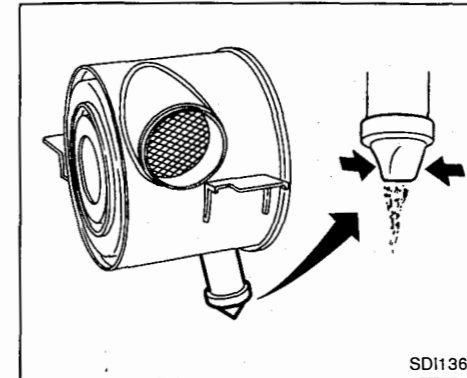
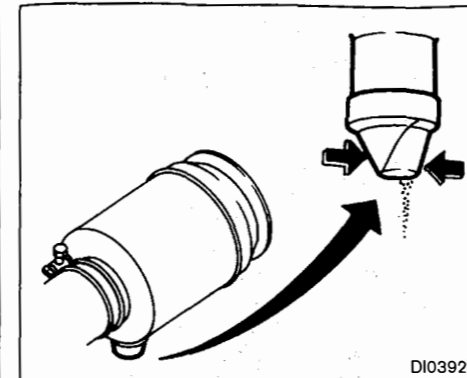
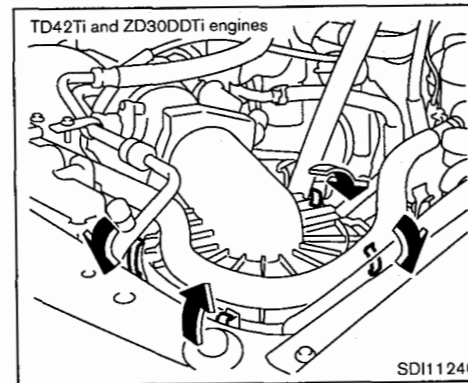
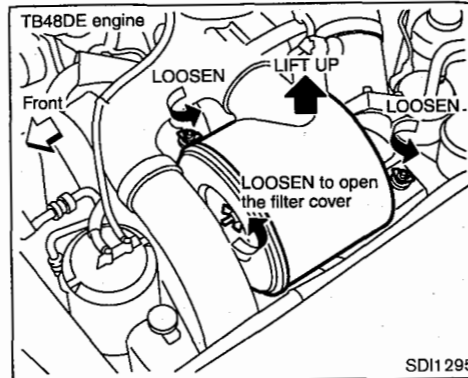
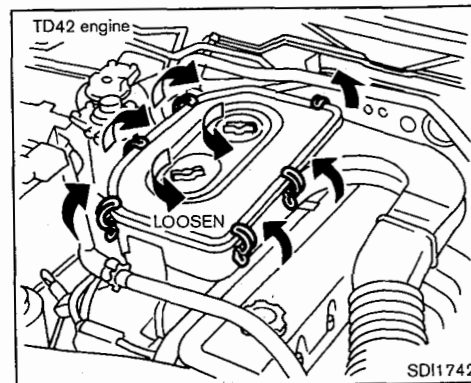

**CYCLONE PRE-AIR CLEANER (if so equipped)**

Periodically pinch the rubber cap located under the cyclone air cleaner (Type A) or the air cleaner (Type B) to remove dust from the cyclone.

## WIPER BLADES

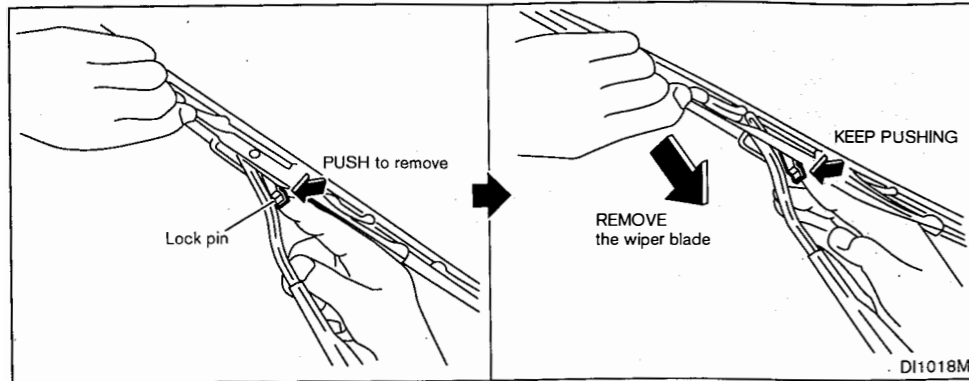

## CLEANING

If your windshield is not clear after using the windshield washer or if a wiper blade chatters when running, wax or other material may be on the blade or windshield.

Clean the outside of the windshield with a washer solution or a mild detergent. Your windshield is clean if beads do not form when rinsing with clear water.

Clean the blade by wiping it with a cloth soaked in a washer solution or a mild detergent. Then rinse the blade with clear water. If your windshield is still not clear after cleaning the blades and using the wiper, replace the blades.

## REPLACING

1. Pull the wiper arm.
2. Push the lock pin, then remove the wiper blade.
3. Insert the new wiper blade to the wiper arm until a click sounds.

### CAUTION:

**After wiper blade replacement, return the wiper arm to its original position. Otherwise it may be damaged when the engine hood is opened.**

**Make sure the wiper blade contacts the glass. Otherwise, the arm may be damaged from wind pressure.**

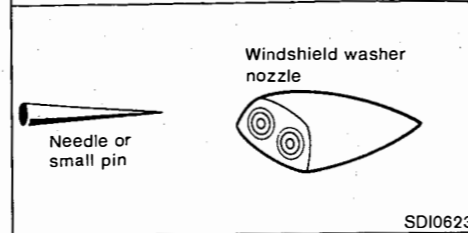
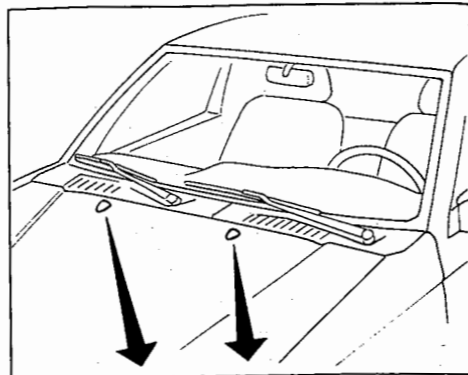

**If you wax the surface of the hood, be careful not to let wax get into the washer nozzle. This may cause clogging or improper windshield washer operation. If wax gets into the nozzle, remove it with a needle or small pin.**

## BRAKE CONDITIONS

### CHECKING PARKING BRAKE

Periodically check the holding ability of the parking brake by parking on a steep hill and holding the vehicle by using only the parking brake. If it does not hold satisfactorily, see a NISSAN dealer.

### CHECKING BRAKE PEDAL

If the brake pedal suddenly goes down further than normal, the pedal feels "spongy" or the vehicle seems to take longer to stop, see a NISSAN dealer.

## FUSES

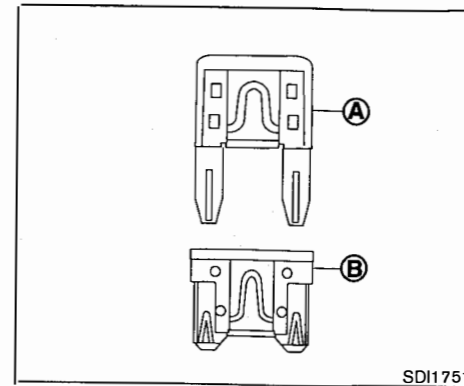

Some vehicles are equipped with engine compartment and passenger compartment fuse boxes that use only type **A** fuses. Other vehicles are equipped with type **A** fuses in the engine compartment fuse box and type **B** fuses in the passenger compartment fuse box.

Type **A** fuses are provided as spare fuses. They are stored in the passenger compartment fuse box.

Type **A** fuses can be installed in the engine compartment and passenger compartment fuse boxes.

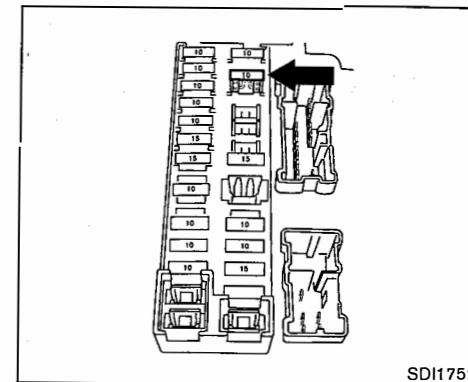

If a type **A** fuse is used to replace a type **B** fuse, the type **A** fuse will not be level with the fuse pocket as shown in the illustration. This will not affect the performance of the fuse. Make sure the fuse is installed in the fuse box securely.

Type **B** fuses cannot be installed in the underhood fuse boxes. Only use type **A** fuses in the underhood fuse boxes.

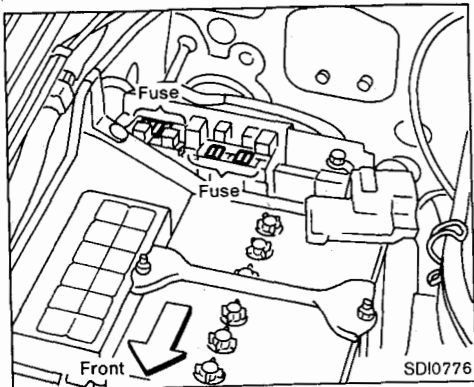

## ENGINE COMPARTMENT

### CAUTION:

**Never use a fuse of higher or lower amperage rating than that specified on the fuse box cover.**

If any electrical equipment does not operate, check for an open fuse.

1. Be sure the ignition switch and the headlight switch are "OFF".
2. Open the engine hood.
3. Remove the fuse box cover.
4. Remove the fuse with the fuse puller located in the passenger compartment fuse box.

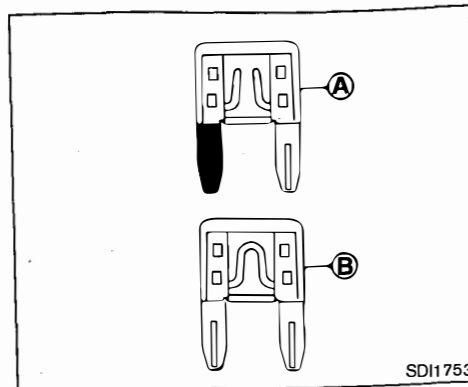

5. If the fuse is open (A), replace it with a new fuse (B).

If a new fuse opens again, have the electrical system checked and repaired by a NISSAN dealer.

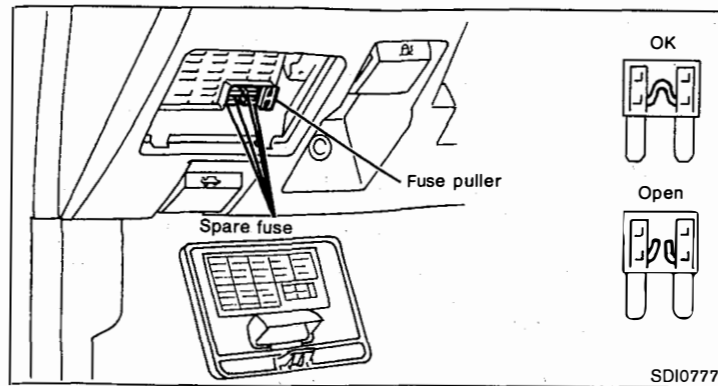

## PASSENGER COMPARTMENT

### CAUTION:

**Never use a fuse of higher or lower amperage rating than that specified on the fuse box cover.**

If any electrical equipment does not operate, check for an open fuse.

1. Be sure the ignition switch and the headlight switch are "OFF".
2. Remove the fuse box lid.
3. Remove the fuse with the fuse puller.
4. If the fuse is open (A), replace it with a new fuse (B).

If a new fuse opens again, have the electrical system checked and repaired by a NISSAN dealer.

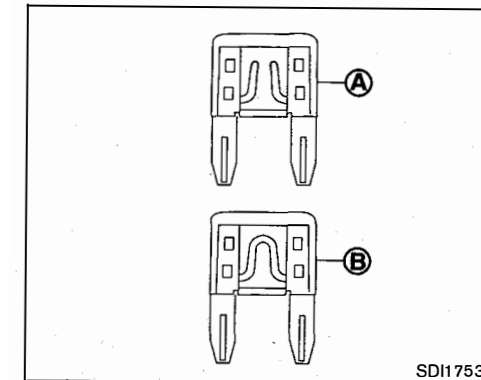

Type A

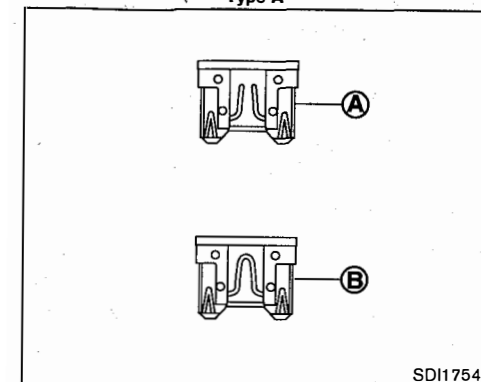

Type B

## LIGHTS

### HEADLIGHTS

#### Replacing

If replacement is required, see a NISSAN dealer.

#### Halogen headlight bulb:

The headlight is a halogen type which uses a replaceable headlight bulb. A bulb can be replaced inside the engine compartment without removing the headlight assembly.

#### CAUTION:

**High pressure halogen gas is sealed inside the halogen bulb. The bulb may break if the glass envelope is scratched or the bulb is dropped. Never touch the glass envelope.**

- **DO NOT TOUCH THE BULB.**
- **Use the same number and wattage as originally installed:**

**Wattage 60/55**

- **Aiming is usually not necessary after replacing the bulb. When aiming adjustment is necessary, contact a NISSAN dealer.**
- **Do not leave the bulb out of the headlight reflector for a long period of time as dust, moisture, smoke may enter the headlight body and affect the perfor-**

**mance of the headlight.**

#### Xenon headlight bulb (if so equipped):



**WARNING:**



**HIGH VOLTAGE**

**When xenon headlights are on, they produce a high voltage. To prevent an electric shock, never attempt to modify or disassemble (including the bulbs for high beam). Always have your xenon headlights replaced at a NISSAN dealer. For additional information, see "Headlight and turn signal switch" in the "2. Instruments and controls" section.**

Fog may temporarily form inside the lens of the exterior lights in the rain or in a car wash. A temperature difference between the inside and the outside of the lens causes the fog. This is not a malfunction. If large drops of water collect inside the lens, contact a NISSAN dealer.

### EXTERIOR LIGHTS

#### Wagon and Hardtop

Item	Wattage (W)
Front turn signal light	21
Front clearance light	5
Front fog light (if so equipped)	55
Side turn signal light (if so equipped)	5
Rear combination light (upper/lower)	
Turn signal	21
Stop/Tail	21/5
Back-up	21
Fog (if so equipped)	21
License plate light	5
High-mounted stop light	21

### Pickup

Item	Wattage (W)
Front combination light	
Turn signal	21
Clearance	5
Front fog light (if so equipped)	55
Side turn signal light (if so equipped)	5
Rear combination light	
Turn signal	21
Stop/Tail	21/5
Back-up	21
License plate light	10

### INTERIOR LIGHTS

Item	Wattage (W)
Room light	10
Personal light (if so equipped)	10

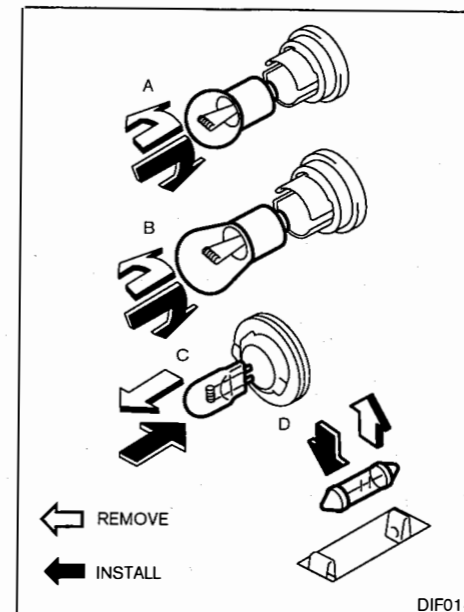

#### Replacement procedures

All other lights are either type A, B, C or D. When replacing a bulb, first remove the lens and/or cover.

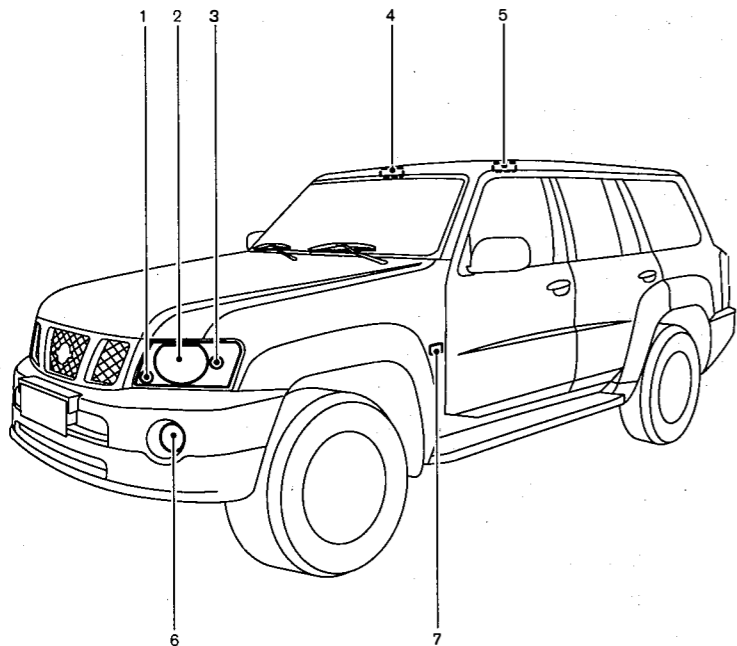

### LIGHT LOCATION

#### Wagon and Hardtop — Front

1. Front clearance light\*
2. Headlight\*
3. Front turn signal light\*
4. Personal light (if so equipped)
5. Room light
6. Front fog light (if so equipped)
7. Side turn signal light (if so equipped)

\*: See a NISSAN dealer for replacement.

SD11705

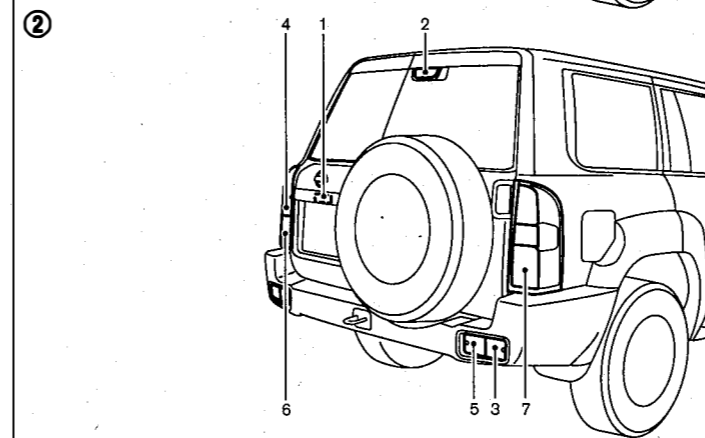
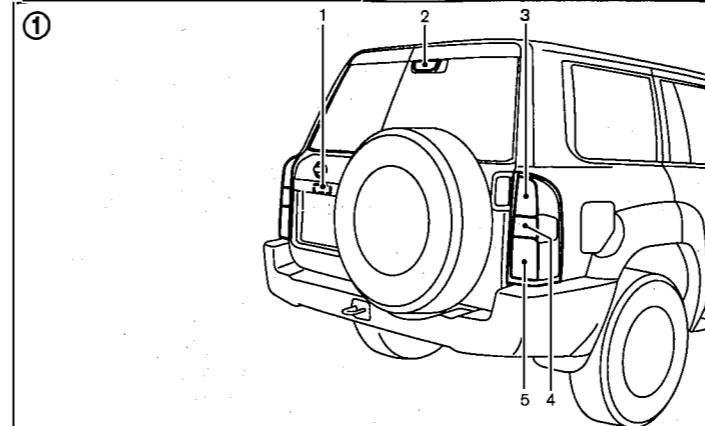

SD11687

#### Wagon and Hardtop — Rear

##### ① Type A:

1. License plate light
2. High-mounted stop light
3. Turn signal light
4. Back-up light
5. Stop/Tail light

##### ② Type B:

1. License plate light
2. High-mounted stop light
3. Turn signal light
4. Back-up light
5. Stop/Tail
6. Rear fog light (LHD model) (if so equipped)
7. Rear fog light (RHD model) (if so equipped)

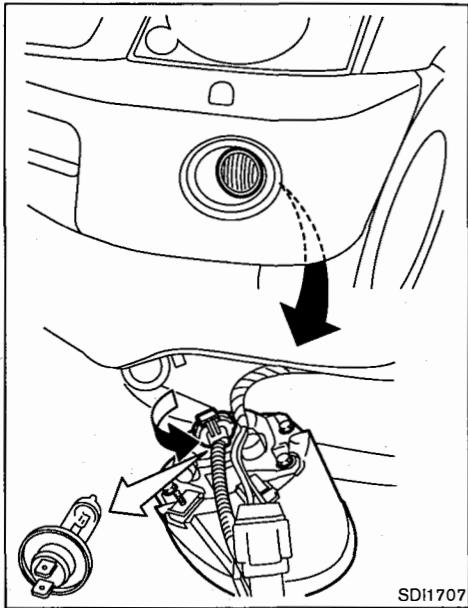

SDI1707

Front fog light

Remove the bulb from the back side.

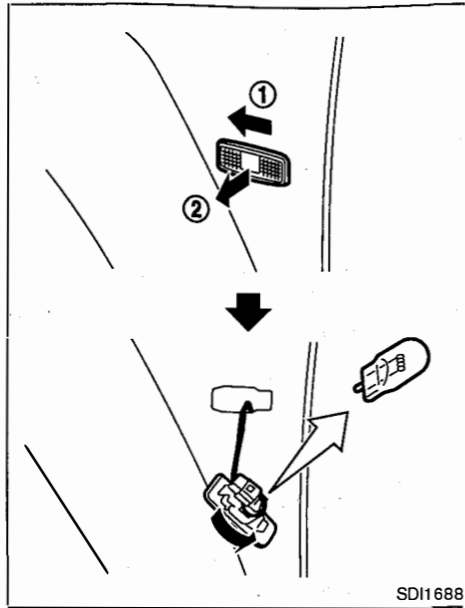

SDI1688

Side turn signal light

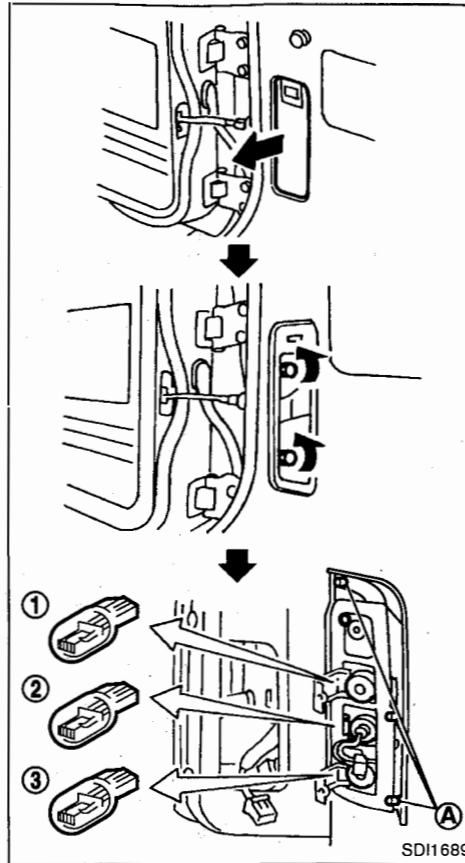

SDI1689

Rear combination light (upper)

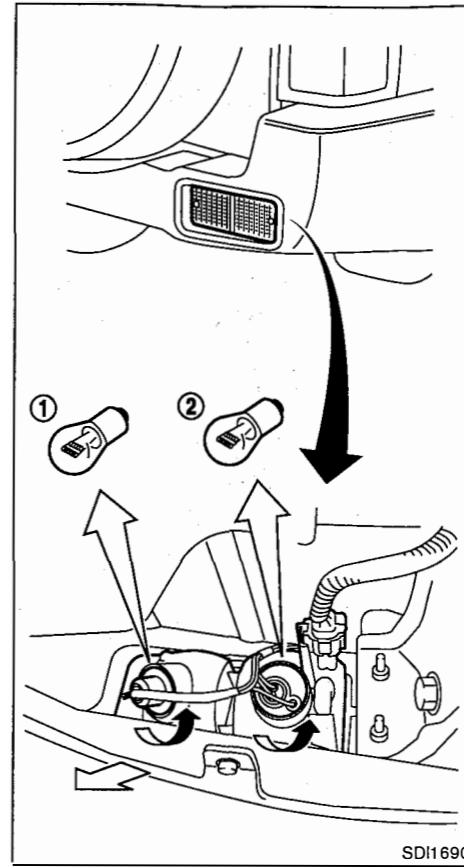

SDI1690

Rear combination light (lower)

The light unit is installed with the cotter pins **(A)**.

- ① Turn signal light
- ② Back-up light
- ③ Stop/Tail light or Rear fog light  
Depending on the vehicles, a reflector is equipped instead of a light bulb.

Remove the bulbs from the back side.

- ① Turn signal light
- ② Stop/Tail light



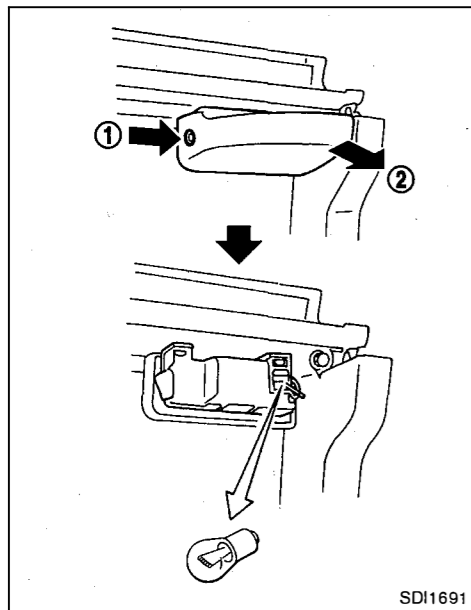

SDI1691

High-mounted stop light

- ① Push and remove the clip.
- ② Pull the unit as shown to remove.

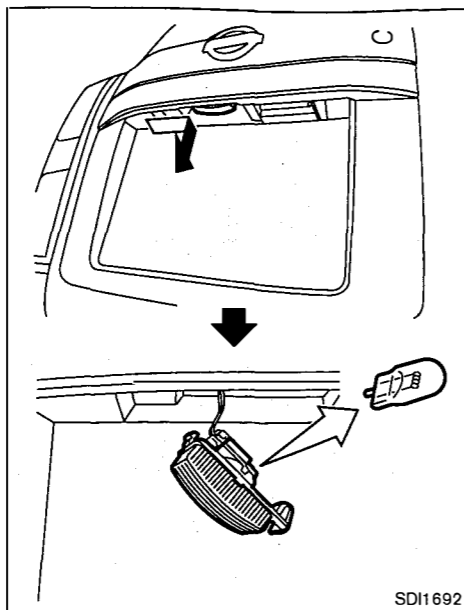

SDI1692

License plate light (Type A)

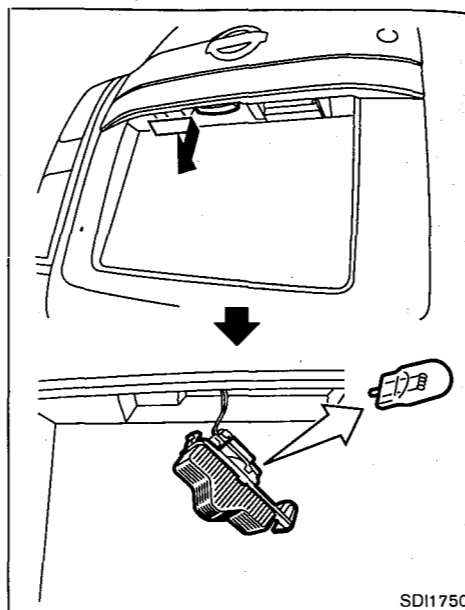

SDI1750

License plate light (Type B)

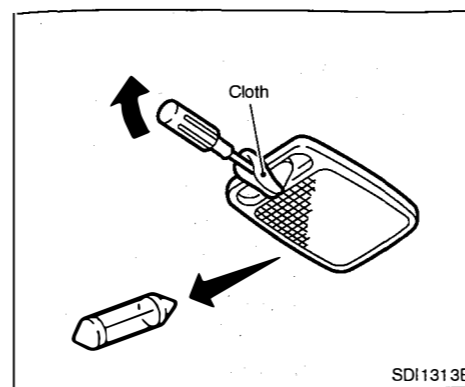

SDI1313B

Room light

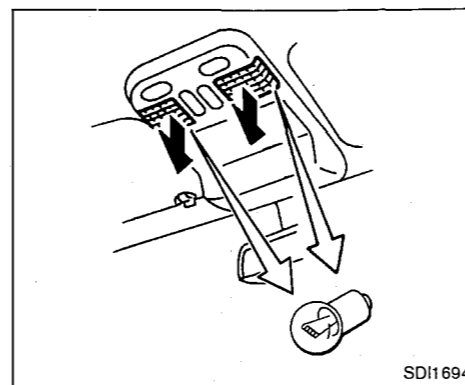

SDI1694

Personal light

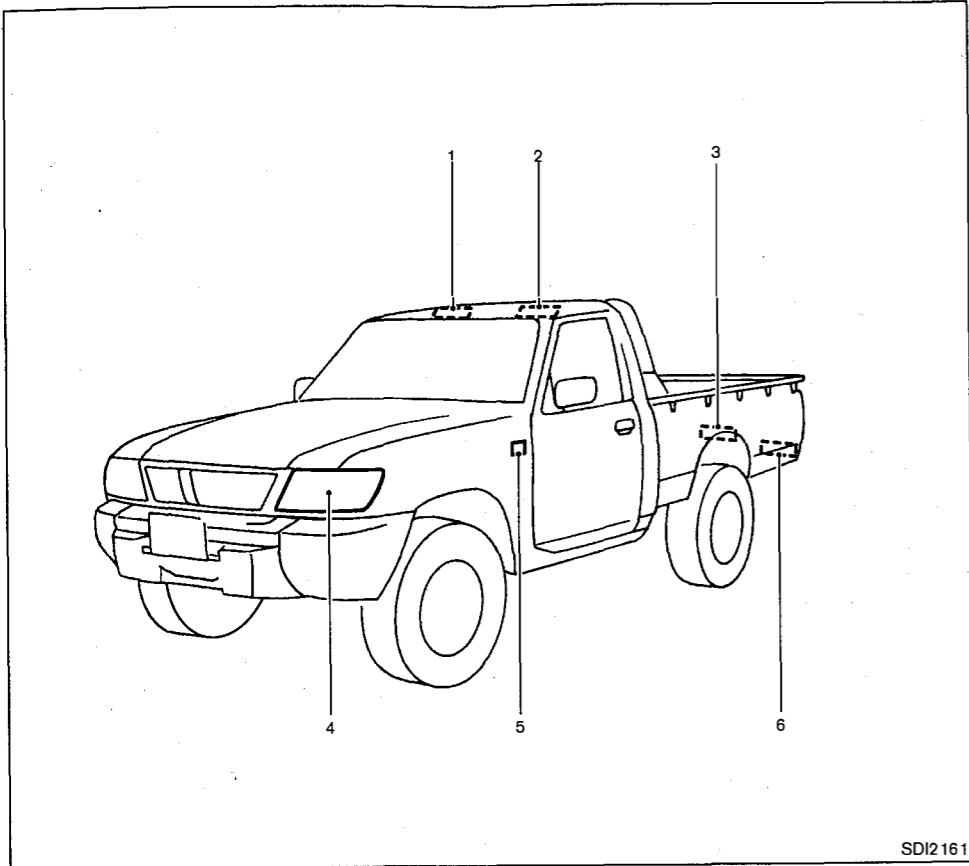

SDI2161

**Pickup**

1. Personal light (if so equipped)
2. Room light
3. License plate light\*1
4. Headlights and front combination light (Turn signal, Clearance)\*2
5. Side turn signal light (if so equipped)
6. Rear combination light (Turn signal, Stop/Tail, Back-up)

\*1: Rear body is an example.

\*2: See a NISSAN dealer for replacement.

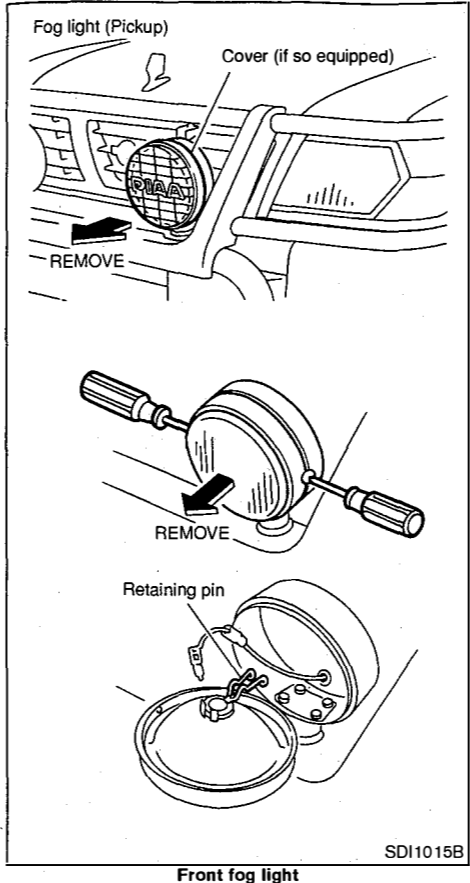

Front fog light

SDI1015B

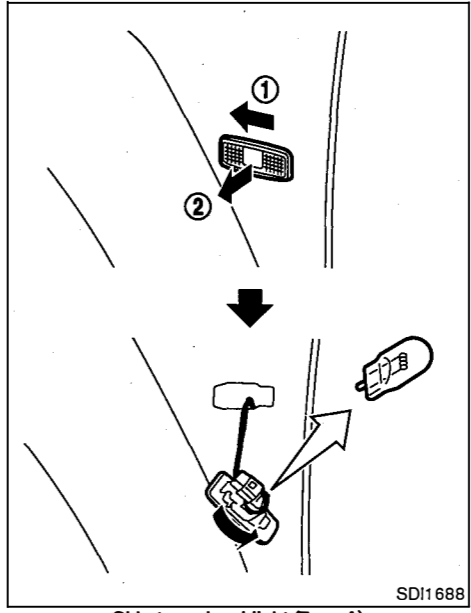

Side turn signal light (Type A)

SDI1688

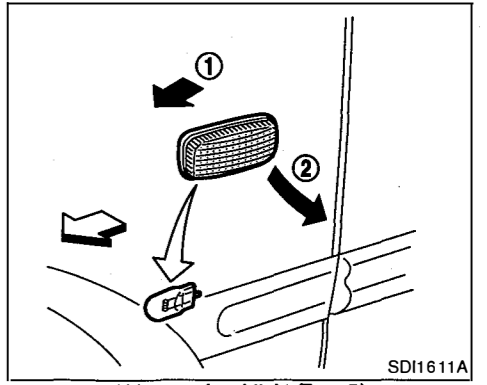

Side turn signal light (Type B)

SDI1611A

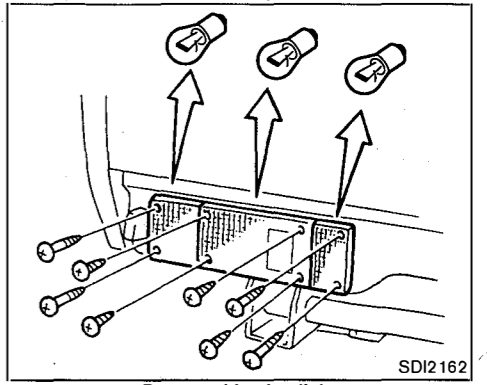

Rear combination light

SDI2162

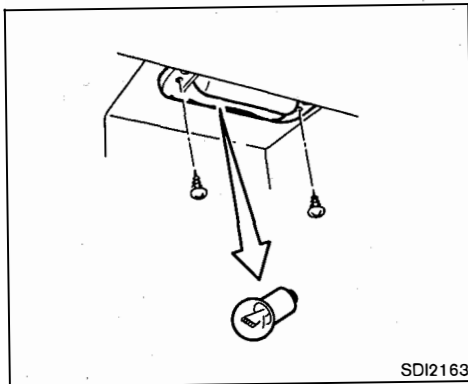

License plate light

SDI2163

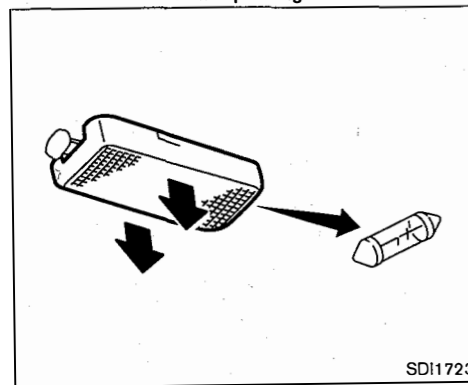

Room light

SDI1723

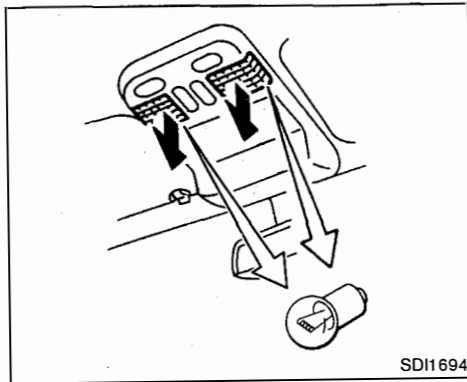

Personal light

SDI1694

## TIRES AND WHEELS

If you have a flat tire, see "6. In case of emergency" section.

### TIRE INFLATION PRESSURE

Periodically check the tire pressure (including spare). Tire pressure should be checked when tires are COLD. COLD tire pressures are shown on the tire placard affixed to the glove box lid or driver side center pillar.

#### CAUTION:

**Incorrect tire pressure may adversely affect tire life and vehicle handling.**

#### COLD pressure:

**After vehicle has been parked for three hours or more or driven less than 1.6 km (1 mile).**

Insufficient pressure can lead to an overheating of the tire and subsequent internal damage. At high speeds, this could result in tread separation and even bursting of the tire.

### TYPES OF TIRES

#### CAUTION:

**When changing or replacing tires, be sure all four tires are of the same type (i.e., Summer, All Season or Snow) and construction. A NISSAN dealer may be able to help you with information about tire type,**

**size, speed rating and availability. Replacement tires may have a lower speed rating than the factory equipped tires, and may not match the potential maximum vehicle speed. Never exceed the maximum speed rating of the tire.**

#### All season tires

NISSAN specifies All Season tires on some models to provide good performance for use all year around, including snowy and icy road conditions. All Season Tires are identified by "ALL SEASON" and/or "M&S" on the tire sidewall. Snow tires have better snow traction than All Season tires and may be more appropriate in some areas.

#### Summer tires

NISSAN specifies summer tires on some models to provide superior performance on dry roads. Summer tire performance in snow and ice will be substantially reduced. Summer tires do not have the tire traction rating "M&S" on the tire sidewall.

If you plan to operate your vehicle in snowy or icy conditions, NISSAN recommends the use of "SNOW" or "ALL SEASON" tires on all four wheels.

#### Snow tires

If snow tires are needed, it is necessary to select

tires equivalent in size and load rating to the original equipment tires. If you do not, it can adversely affect the safety and handling of your vehicle.

Generally, snow tires will have lower speed ratings than factory equipped tires and may not match the potential maximum vehicle speed. Never exceed the maximum speed rating of the tire.

For additional traction on icy roads, studded tires may be used. However, some provinces and states prohibit their use. Check local, state and provincial laws before installing studded tires. Skid and traction capabilities of studded snow tires, on wet or dry surfaces, may be poorer than that of non-studded snow tires.

### TIRE CHAINS

Use of tire chains is prohibited according to location. Check the local laws before installing tire chains. When installing tire chains, make sure they are of proper size for the tires on your vehicle and are installed according to the chain manufacturer's suggestions. Use chain tensioners when recommended by the tire chain manufacturer to ensure a tight fit. Loose end links of the tire chain must be secured or removed to prevent the possibility of whipping action damage to the fenders or undercarriage. In addition, drive at a reduced speed. Otherwise, your ve-

hicle may be damaged and/or vehicle handling and performance may be adversely affected.

**Tire chains must be installed only on the rear wheels and not on the front wheels.**

Do not drive with tire chains on paved roads which are clear of snow. Driving with chains in such conditions can cause damage to the various mechanisms of the vehicle due to over-stress. When driving on clear paved roads, be sure to change to 2WD.

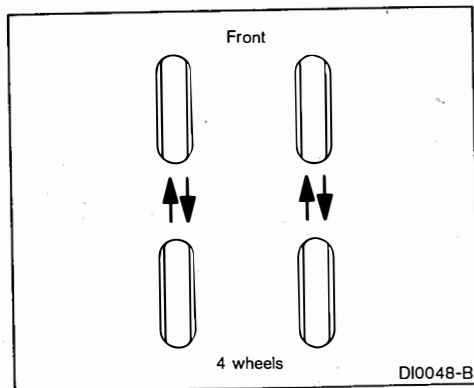

### TIRE ROTATION

NISSAN recommends that tires be rotated every 5,000 km (3,000 miles) for 4WD vehicles.

See "Flat tire" in the "6. In case of emergency" section for tire replacing procedures.



#### WARNING:

- After rotating the tires, adjust the tire pressure.
- Retighten the wheel nuts when the vehicle has been driven for the first 1,000 km (600 miles) (also in cases of a flat tire, etc.).

- Incorrect tire selection, fitting, care or maintenance can affect vehicle safety with risk of accident and injury. If in doubt, consult a NISSAN dealer or the tire manufacturer.

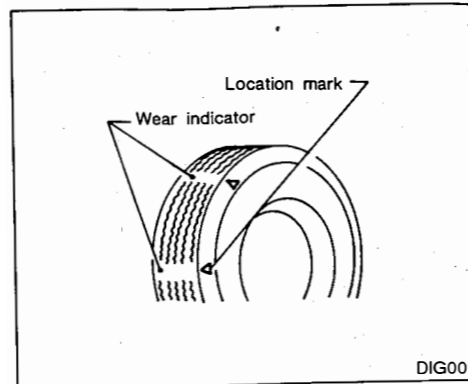

### TIRE WEAR AND DAMAGE

Tires should be periodically inspected for wear, cracking, bulging, or objects caught in the tread. If excessive wear, cracks, bulging, or deep cuts are found, the tire should be replaced.

The original tires have a built-in tread wear indicator. When the wear indicator is visible, the tire should be replaced.

### TIRE AGE

Remember tire age. Never use a tire over six years old, regardless of whether it has been used or not.

Tires degrade with age as well as the use they are subjected to, have your tires checked and

balanced frequently by a recognized tire agent. Report all accidents where the tire is knocked however minor.

### CHANGING WHEELS AND TIRES

When replacing a tire, use the same size and load carrying capacity as originally equipped. Recommended types and sizes are shown in "Tires and wheels" in the "9. Technical information" section. The use of tires other than those recommended or the mixed use of tires of different brands, construction (bias, bias-belted or radial), or tread patterns can adversely affect the ride, braking, handling, ground clearance, body-to-tire clearance, snow chain clearance, speedometer calibration, headlight aim and bumper height. **Some of these effects may lead to accidents and could result in serious personal injury.**

If the wheels are changed for any reason, always replace with wheels which have the same offset dimension. Wheels of a different offset could cause early tire wear, possibly degraded vehicle handling characteristics and/or interference with the brake discs/drums. Such interference can lead to decreased braking efficiency and/or early brake pad/shoe wear.



#### WARNING:

Do not install a deformed wheel or tire even if it has been repaired. Such wheels or tire could have structural damage and could fail without warning.

### 4x4 TIRES FOR FOUR-WHEEL DRIVE (4WD) MODEL

#### CAUTION:

Always use tires of the same size, brand, construction (bias, bias-belted or radial), and tread pattern on all four wheels. Failure to do so may result in a circumference difference between tires on the front and rear axles which will cause excessive tire wear and may damage the transmission, transfer case and differential gears.

**ONLY use spare tires specified for each four-wheel drive (4WD) model.**

### WHEEL BALANCE

Unbalanced wheels may affect vehicle handling and tire life. Even with regular use, wheels can get out of balance. Therefore, they should be balanced as required.

### 4x4 CLUTCH HOUSING

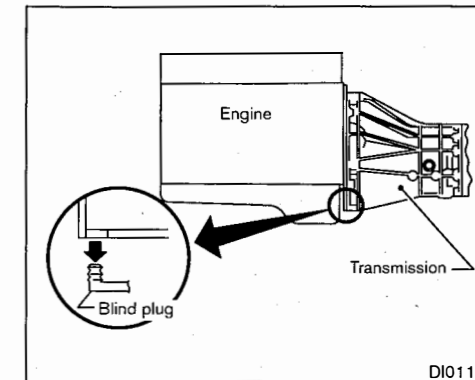

### CHECKING WATER ENTRY

Whenever you drive in deep water or mud, check water entry in the clutch housing by removing the blind plug at the bottom of the transmission case. After checking, be sure to reinstall the plug.

## KNUCKLE FLANGE

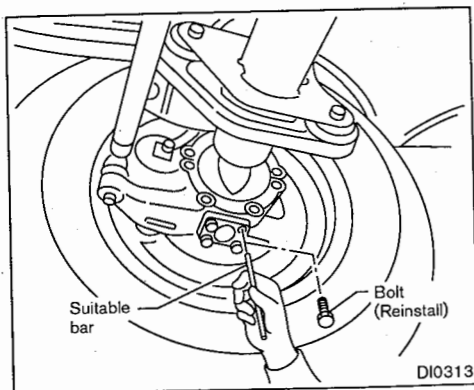

### CHECKING WATER ENTRY

Whenever you drive in deep water or mud, check for water entry in knuckle flange by removing one of the lower knuckle flange bearing cap bolts and probing with a suitable thin bar. After checking, be sure to reinstall the bolt with a tightening torque of 30 to 40 N·m (3.1 to 4.1 kg·m, 22 to 30 ft·lb).

## 9 Technical information

Recommended fuel/lubricants and capacities .....	9-2	Vehicle identification number (VIN) plate .....	9-12
Fuel recommendation .....	9-4	Vehicle identification number (chassis number)....	9-13
Recommended SAE viscosity number .....	9-4	Built date plate (for Australia) .....	9-13
Air conditioning system refrigerant and lubricant recommendations .....	9-5	Engine serial number .....	9-13
Engine .....	9-6	Tire placard .....	9-14
Tires and wheels.....	9-8	Air conditioner specification label .....	9-15
Dimensions .....	9-9	Rear license plate (for Europe) .....	9-15
When travelling or registered in another country .....	9-12	Radio approval number and information (for Europe) .....	9-15
Vehicle identification .....	9-12	For Europe.....	9-15
Vehicle identification plate .....	9-12		

## RECOMMENDED FUEL/ LUBRICANTS AND CAPACITIES

The following values are approximate capacities. The actual refill capacities may be a little different. When refilling, follow the procedure instructed in the "8. Maintenance and do-it-yourself" section to determine the proper refill capacity.

			Capacity (Approximate)				Recommended fuel and lubricants	
			Wagon and Hardtop		Pickup			
			Liter	Imp measure	Liter	Imp measure		
Fuel	Main tank	95	20-7/8 gal	90 or 95*2	19-3/4 or 20-7/8 gal*2	See "Fuel recommendation".		
	Sub tank*3	Gasoline Diesel	40 or 38*4 40 or 32*4	8-3/4 or 8-3/8*4 8-3/4 or 7*4	80		17-5/8 gal	
Engine oil (Refill)	With oil filter	TB45E/45S	7.6	6-3/4 qt	7.6	6-3/4 qt	Gasoline engine: Genuine NISSAN engine oil*1 API grade SE, SF, SG, SH, SJ, SL or SM*1 ILSAC grade GF-1, GF-2, GF-3, GF-4 or SG+*1 For Europe, ACEA A2 or A3*1 is also recommended. Diesel engine: Genuine NISSAN engine oil*1 (For Europe) API grade CF-4, ACEA B3 or B3/E3, or JASO DH-1*1, *5 (Except for Europe) API grade CC, CD, CE, CF, CF-4 or JASO DH-1*1 for TD42*10, and API grade CE, CF, CF-4 or JASO DH-1 for ZD30DDTi*1, *5	
		TB48DE	6.8	6 qt	—	—		
		TD42/TD42Ti	10.5	9-1/4 qt	10.5	9-1/4 qt		
		ZD30DDTi	8.2	7-1/4 qt	8.2	7-1/4 qt		
		TB45E/45S	7.3	6-3/8 qt	7.3	6-3/8 qt		
	Without oil filter	TB48DE	6.5	5-3/4 qt	—	—		
		TD42/TD42Ti	9.3	8-1/8 qt	9.3	8-1/8 qt		
		ZD30DDTi	7.7	6-4/5 qt	7.7	6-4/5 qt		
		Cooling system (with reservoir)	LHD	11.7	10-1/4 qt	12.0		10-5/8 qt
			RHD	12.6*8	11-1/8 qt*8			
With front heater	TB45E/45S	LHD	13.0	11-1/2 qt	—	—		
		RHD	10.9	9-5/8 qt	—	—		
	TB48DE*6	LHD	13.9*8	12-1/4 qt*8	—	—		
		RHD	13.2	11-5/8 qt	—	—		
	TD42	15.1	13-1/4 qt	15.1	13-1/4 qt			
	TD42Ti	14.7	13 qt	14.7	13 qt			
	ZD30DDTi*7	LHD	12.9	11-3/8 qt	—	—		
		RHD	14.0*8	12-3/8 qt*8	—	—		
Without front heater	TB45E/45S	11.0	9-5/8 qt	11.3	10 qt			
	TB48DE	12.5	11 qt	—	—			
	TD42	14.4	12-5/8 qt	14.4	12-5/8 qt			
	ZD30DDTi	12.0	10-5/8 qt	—	—			
						Genuine NISSAN Engine Coolant or equivalent in its quality*9		

\*1: For further details, see "Recommended SAE viscosity number".

\*2: For models with sub tank \*3: For Wagon and Pickup models \*4: For Australia \*5: Never use API CG-4.

\*6: For Europe, 0.8 liter (3/4 qt) should be added to each numerical value. \*7: For Europe, 0.3 liter (1/4 qt) should be added to each numerical value. \*8: With rear heater.

\*9: Use NISSAN Genuine Engine Coolant, or equivalent in its quality, in order to avoid possible aluminum corrosion within the engine cooling system caused by the use of non-genuine engine coolant.

Note that any repairs for the incidents within the engine cooling system while using non-genuine engine coolant may not be covered by the warranty even if such incidents occurred during the warranty period.

\*10: For Pickup models for South Africa, only API grade CF-4 or JASO DH-1 grade oil is recommended.

	Capacity (Approximate)		Recommended fuel and lubricants
	Liter	Imp measure	
Manual transmission gear oil	—	—	Genuine NISSAN Manual Transmission Fluid (MTF) HQ Multi 75W-85 or API GL-4, Viscosity SAE 75W-85
Differential gear oil (without limited slip differential)	—	—	Genuine NISSAN Differential Oil Hypoid Super GL-5 80W-90 or API GL-5*1
Differential gear oil (with limited slip differential)	—	—	Genuine NISSAN Differential Oil Hypoid LSD GL-5 80W-90 or equivalent
Transfer fluid	—	—	Genuine NISSAN Matic C ATF or equivalent*2 or API GL-4 Viscosity SAE 75W-90*1
Automatic transmission fluid (5-speed models)	Ask a NISSAN dealer for servicing.		Genuine NISSAN Matic J ATF*3
Automatic transmission fluid (4-speed models)			Genuine NISSAN Matic D ATF or equivalent (if available)
Power steering fluid	Refill to the proper fluid level according to the instructions in the "8. Maintenance and do-it-yourself" section		Genuine NISSAN PSF or equivalent*4 Genuine NISSAN brake fluid or equivalent DOT 3 or DOT 4 for Europe*5
Brake and clutch fluid			Genuine NISSAN brake fluid or equivalent DOT 3 except for Europe
Multi-purpose grease	—	—	NLGI No. 2 (Lithium soap base)
Propeller shaft grease	—	—	NLGI No. 2 (Molybdenum disulphide lithium soap base)
Air conditioning system refrigerant	—	—	HFC-134a (R-134a)
Air conditioning system lubricants	—	—	NISSAN A/C System Oil Type S or exact equivalent

\*1: For further details, see "Recommended SAE viscosity number".

\*2: Genuine NISSAN Matic D ATF or equivalent (if available).

\*3: **Using automatic transmission fluid other than Genuine NISSAN Matic J ATF will cause deterioration in driveability and automatic transmission durability, and may damage the automatic transmission, which is not covered by the warranty.**

\*4: DEXRON™ VI type ATF can be used.

\*5: Do not mix different type fluids (DOT 3 and DOT 4).

## FUEL RECOMMENDATION

### Gasoline engine

Models equipped with three way catalyst:

Unleaded gasoline of 91 octane (RON) or above.

#### CAUTION:

**Do not use leaded gasoline. Using leaded gasoline will damage the three way catalyst.**

Models not equipped with three way catalyst:

Unleaded or leaded gasoline of 91 octane (RON) or above.

Use unleaded fuel if instructed on the fuel filler lid.

### Diesel engine\*

Diesel fuel of above 45 cetane for TD42 and TD42Ti engines and at least 50 cetane for ZD30DDTi engine

\* If two types of diesel fuel are available, use summer or winter fuel properly according to the following temperature conditions.

- Above  $-7^{\circ}\text{C}$  ( $20^{\circ}\text{F}$ ) ... Summer type diesel fuel.

- Below  $-7^{\circ}\text{C}$  ( $20^{\circ}\text{F}$ ) ... Winter type diesel fuel.

#### CAUTION:

● **Do not use home heating oil, gasoline, or other alternate fuels in your diesel engine. The use of these can cause engine damage.**

● **Do not use summer fuel at temperatures below  $-7^{\circ}\text{C}$  ( $20^{\circ}\text{F}$ ). The cold temperatures will cause wax to form in the fuel. As a result, it may prevent the engine from running smoothly.**

● **Do not add gasoline or other alternate fuels to diesel fuel.**

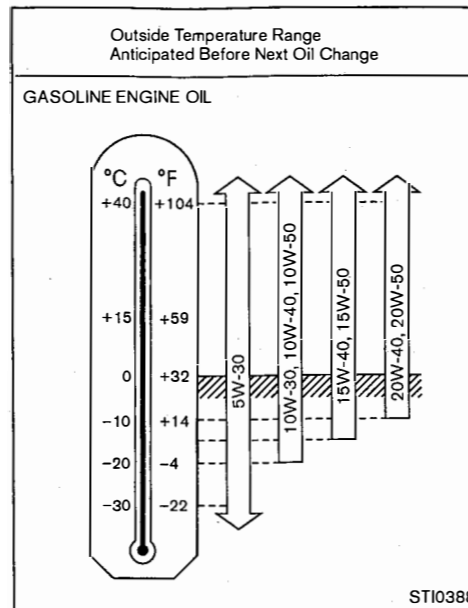

### RECOMMENDED SAE VISCOSITY NUMBER

Gasoline engine oil

**5W-30 is preferable.**

**If 5W-30 is not available, select the viscosity, from the chart, that is suitable for the outside temperature range.**

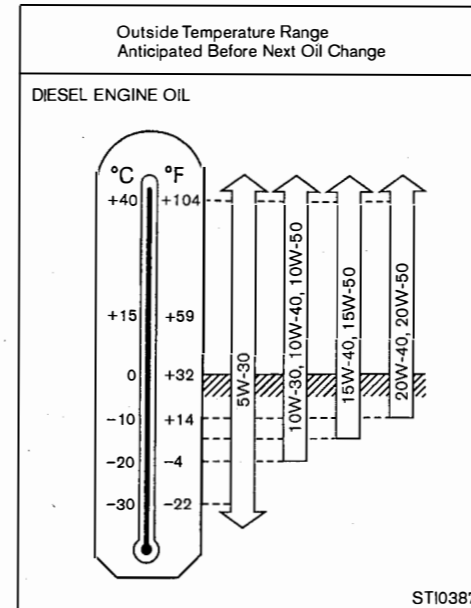

Diesel engine oil

**5W-30 is preferable. If 5W-30 is not available, select the viscosity, from the chart, that is suitable for the outside temperature range.**

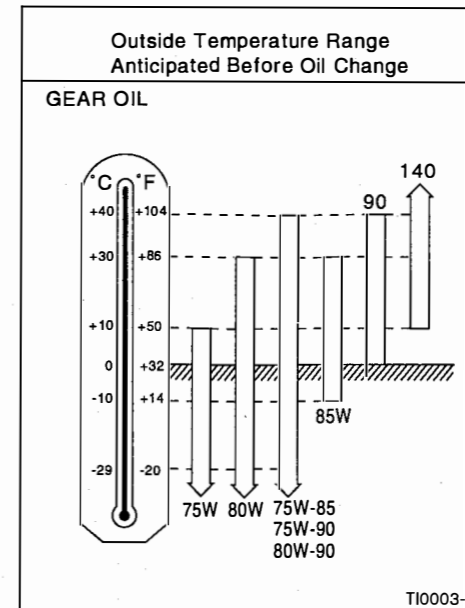

Gear oil

● **For cold and warm areas:**

**75W-90 for transfer and 80W-90 for differential are preferable.**

● **For hot areas:**

**90 for differential is suitable for ambient**

**temperatures below  $40^{\circ}\text{C}$  ( $104^{\circ}\text{F}$ ).**

- **For extremely hot areas and the Middle East:**

**140 for differential is preferable.**

### AIR-CONDITIONING SYSTEM REFRIGERANT AND LUBRICANT RECOMMENDATIONS

**The air conditioning system in this NISSAN vehicle must be charged with the refrigerant HFC-134a (R-134a) and the lubricant, NISSAN A/C System Oil Type S or the exact equivalents. Use of any other refrigerants or lubricants will cause severe damage and you will need to replace your vehicle's entire air conditioning system.**

The release of refrigerant into the atmosphere is not recommended. The new refrigerant HFC-134a (R-134a) in your NISSAN vehicle will not harm the earth's ozone layer. However it may contribute in a small part to global warming. NISSAN recommends that the refrigerant be recovered and recycled.

Contact a NISSAN dealer when servicing your air conditioning system.

## ENGINE

### Gasoline engine

Model	TB45S	TB45E	TB48DE (Type A)	TB48DE (Type B)
Type	Gasoline, 4-cycle	Gasoline, 4-cycle	Gasoline, 4-cycle	←
Cylinder arrangement	6-cylinder in-line	6-cylinder in-line	6-cylinder in-line	←
Bore x Stroke	mm (in) 99.5 x 96.0 (3.917 x 3.780)	99.5 x 96.0 (3.917 x 3.780)	99.5 x 102.0 (3.917 x 4.016)	←
Displacement	cm <sup>3</sup> (cu in) 4,479 (273.31)	4,479 (273.31)	4,759 (290.39)	←
Firing order	1-5-3-6-2-4	1-5-3-6-2-4	1-5-3-6-2-4	←
Idling speed	rpm			
M/T	650	650	675	—
A/T	—	—	675 (in "N" position)	←
Ignition timing (BTDC)	degree			
M/T	10°	5°	5°	—
A/T	—	—	5° (in "N" position)	10° (in "N" position)
Spark plugs			(Conventional)	(Platinum-tipped)
Standard type	BPR5E	BPR5E-11	LFR5A-11	PLFR5A-11
Hot type	BPR4E	BPR4E-11	LFR4A-11	PLFR4A-11
Cold type	BPR6E	BPR6E-11	LFR6A-11	PLFR6A-11
Spark plug gap	mm (in) 0.8 to 0.9 (0.031 to 0.035)	1.0 to 1.1 (0.039 to 0.043)	1.0 to 1.1 (0.039 to 0.043)	1.1 (0.043)
Camshaft operation	Timing chain	Timing chain	Timing chain	Timing chain

### Diesel engine

Model	TD42 and TD42Ti	ZD30DDTi
Type	Diesel, 4-cycle	Diesel, 4-cycle
Cylinder arrangement	6-cylinder in-line	4-cylinder in-line
Bore x Stroke	mm (in) 96.0 x 96.0 (3.780 x 3.780)	96.0 x 102.0 (3.780 x 4.016)
Displacement	cm <sup>3</sup> (cu in) 4,169 (254.39)	2,953 (180.19)
Firing order	1-4-2-6-3-5	1-3-4-2
Idling speed	rpm	
M/T	700	750
A/T	—	750 (in "N" position)
Camshaft operation	Timing gear	Timing chain



## TIRES AND WHEELS

### Wagon and Hardtop models

Road wheel						
Size	16 × 5.50F SDC	16 × 6JJ	16 × 6JJ	16 × 8JJ	17 × 8JJ	
Offset	mm (in)	15 (0.59)	35 (1.38)	25 (0.98)	10 (0.39)	10 (0.39)
Tire size	7.50R16-8PRLT	235/80R16 109S 235/80R16LT	235/85R16LT	265/70R16 112S 265/70R16LT 275/70R16 114H	275/65R17 114H	

### Pickup model

Road wheel						
Size	16 × 5.50F SDC		16 × 6.5JJ		16 × 8JJ	
Offset	mm (in)	15 (0.59)	30 (1.18)		10 (0.39)	
Tire size	7.50R16C 112/110R 7.50R16-8PRLT		LT235/85R16 114/111Q		LT265/75R16 112/109S	

## DIMENSIONS

### For Europe

Body type		Wagon	Hardtop
Overall length	mm (in)	5,145 (202.6)*1, *4	4,525 (178.1)*1, *4
		5,045 (198.6)*2	4,475 (176.2)*2
		5,095 (200.6)*3	4,620 (181.9)*3
Overall width	mm (in)	1,940 (76.4)*1, *3	1,940 (76.4)*1, *3
		1,840 (72.4)*2	1,840 (72.4)*2
Overall height	mm (in)	1,855 (73.0)	1,840 (72.4)
Front tread	mm (in)	1,605 (63.2)*1, *3	1,605 (63.2)*1, *3
		1,555 (61.2)*2	1,555 (61.2)*2
Rear tread	mm (in)	1,625 (64.0)*1, *3	1,625 (64.0)*1, *3
		1,575 (62.0)*2	1,575 (62.0)*2
Wheelbase	mm (in)	2,970 (116.9)	2,400 (94.5)

- \*1: For models equipped with 275/65R17 tires  
 \*2: For models equipped with 235/80R16 tires  
 \*3: For models equipped with 265/70R16 tires  
 \*4: 50 mm (1.97 in) is added with spare tire cover.

For Australia

Body type		Wagon	Pickup
Overall length	mm (in)	5,050 (198.8)*1, *6	4,940 (194.5)*7
		4,950 (194.9)*2, *3	5,115 (201.4)*8
Overall width	mm (in)	1,940 (76.4)*1	1,840 (72.4)*3, *5
		1,840 (72.4)*2, *3	1,940 (76.4)*4
Overall height	mm (in)	1,855 (73.0)*1, *2	1,875 (73.8)*3, *4, *7
		1,875 (73.8)*3	1,870 (73.6)*5, *7
Front tread	mm (in)	1,605 (63.2)*1	1,595 (62.8)*3
		1,555 (61.2)*2	1,605 (63.2)*4
		1,595 (62.8)*3	1,565 (61.6)*5
Rear tread	mm (in)	1,625 (64.0)*1	1,615 (63.6)*3, *7
		1,575 (62.0)*2	1,625 (64.0)*4, *7
		1,615 (63.6)*3	1,585 (62.4)*5, *7
			1,505 (59.3)*3, *8
		1,515 (59.6)*4, *8	1,475 (58.1)*5, *8
Wheelbase	mm (in)	2,970 (116.9)	2,970 (116.9)

\*1: For models equipped with 275/70R16 tires, 275/65R17 tires or 265/70R16 tires

\*2: For models equipped with 235/80R16 tires

\*3: For models equipped with 7.50R16 tires

\*4: For models equipped with LT265/75R16 tires

\*5: For models equipped with LT235/85R16 tires

\*6: On front spoiler equipped models, 30 mm (1.18 in) is added.

\*7: Rear coil spring suspension

\*8: Rear leaf spring suspension

Except for Europe and Australia

Body type		Wagon	Hardtop	Pickup
Overall length*1	mm (in)	5,075 (199.8)*2, *6	4,505 (177.4)*2, *6	5,100 (200.8)
		5,040 (198.4)*3, *7	4,460 (175.6)*4, *8	5,130 (202.0)*11
		5,030 (198.0)*4, *8	4,510 (177.6)*5, *9	5,220 (205.5)*12
		5,080 (200.0)*5, *9		5,295 (208.5)*13
				5,175 (203.7)*15
Overall width	mm (in)	1,940 (76.4)*2, *5	1,940 (76.4)*2, *5	1,840 (72.4)
		1,840 (72.4)*3, *4	1,840 (72.4)*4	1,880 (74.0)*14
Overall height	mm (in)	1,855 (73.0)*2, *4, *5	1,840 (72.4)*2, *4	1,865 (73.4)
		1,875 (73.8)*3		1,860 (73.2)*15
Front tread	mm (in)	1,605 (63.2)*2, *5		
		1,595 (62.8)*3	1,605 (63.2)*2, *5	1,595 (62.8)
		1,555 (61.2)*4	1,555 (61.2)*4	1,565 (61.6)*15
Rear tread*10	mm (in)	1,625 (64.0)*2, *5	1,625 (64.0)*2, *5	1,505 (59.3)
		1,615 (63.6)*3	1,575 (62.0)*4	1,475 (58.1)*15
		1,575 (62.0)*4		
Wheelbase	mm (in)	2,970 (116.9)	2,400 (94.5)	2,970 (116.9)

\*1: On front spoiler equipped models, 30 mm (1.18 in) is added to the overall length. With winch, 15 mm (0.59 in) is added. For Pickup models, the guard bar adds 75 mm (2.95 in) to the overall length.

\*2: For models equipped with 265/70R16 tires

\*3: For models equipped with 7.50R16 tires

\*4: For models equipped with 235/80R16 tires

\*5: For models equipped with 275/70R16 tires or 275/65R17 tires

\*6: 20 mm (0.79 in) is added with pintle hook, and 55 mm (2.17 in) is added with spare tire cover.

\*7: 90 mm (3.54 in) is added with spare tire cover.

\*8: 100 mm (3.94 in) is added with spare tire cover.

\*9: 15 mm (0.59 in) is added with pintle hook, and 30 mm (1.18 in) is added with spare tire cover.

\*10: On drum brake equipped Wagon or Hardtop models, 5 mm (0.20 in) is subtracted from the rear tread.

\*11: For South Africa, Namibia and Botswana (models equipped with front side resin bumper)

\*12: For models equipped with rear step bumper

\*13: For models equipped with front guard bar and rear step bumper

\*14: With front guard bar

\*15: For models equipped with TD42Ti engine

## WHEN TRAVELLING OR REGISTERED IN ANOTHER COUNTRY

When planning to travel in another country, you should first find out if the fuel available is suitable for your vehicle's engine.

Using fuel with too low an octane/cetane rating may cause engine damage. Therefore, avoid taking your vehicle to areas where appropriate fuel is not available.

When transferring the registration of your vehicle to another country, state, province or district, check with the local authorities that the vehicle complies with the requirements and it may not be possible to adapt the vehicle. In some cases, a vehicle cannot meet the legal requirements and in others it may be necessary to modify the vehicle to meet local laws and regulations.

The laws and regulations for motor vehicle emission control and safety standards vary according to the country, state, province or district; therefore, vehicle specifications may differ.

When any vehicle is to be taken into another country, state, province or district and registered, its modifications, transportation, and registration are the responsibility of the user. NISSAN is not responsible for any inconvenience that may result.

## VEHICLE IDENTIFICATION

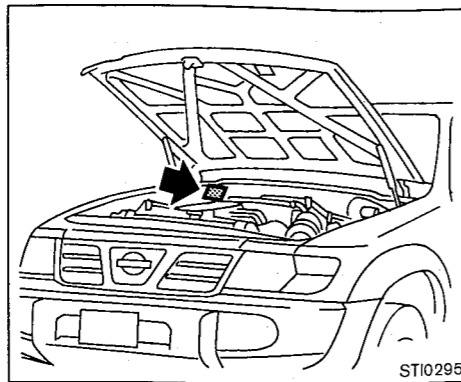

### VEHICLE IDENTIFICATION PLATE

The plate is affixed as shown.

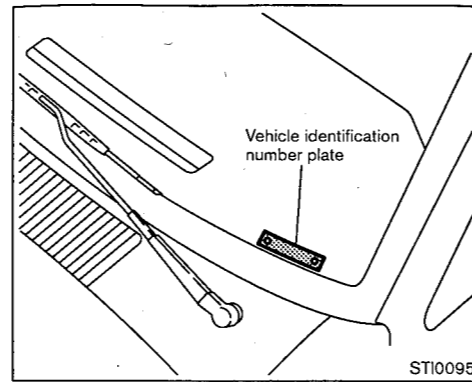

### VEHICLE IDENTIFICATION NUMBER (VIN) PLATE (if so equipped)

The vehicle identification number plate is attached as shown. This number is the identification for your vehicle and is used in the vehicle registration.

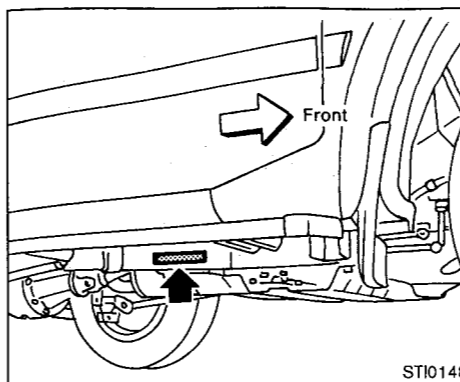

### VEHICLE IDENTIFICATION NUMBER (chassis number)

The number is stamped as shown.

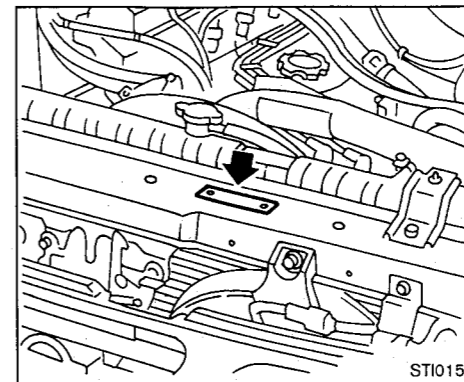

### BUILT DATE PLATE (for Australia)

Built date means the calendar months and the year in which the body shell and power train sub-assemblies are conjoined and the vehicle is driven or moved from the production line.

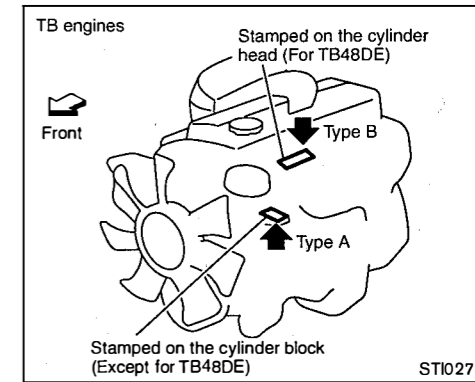

### ENGINE SERIAL NUMBER

The number is stamped on the engine as shown.

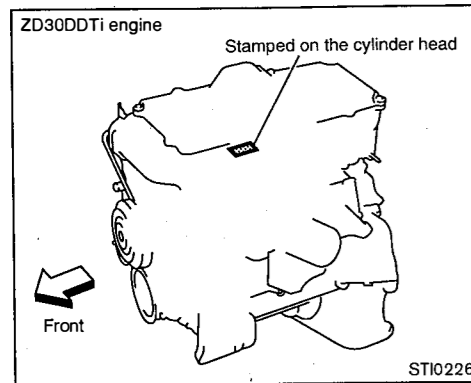
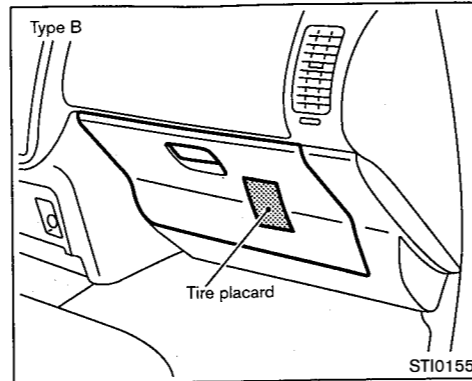
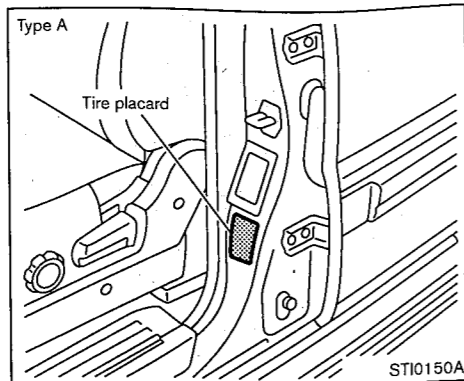
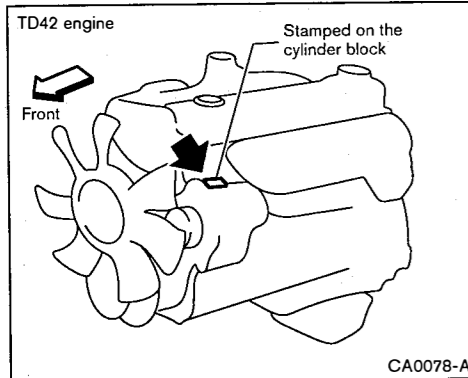

### TIRE PLACARD

The cold tire pressure is shown on the tire placard.

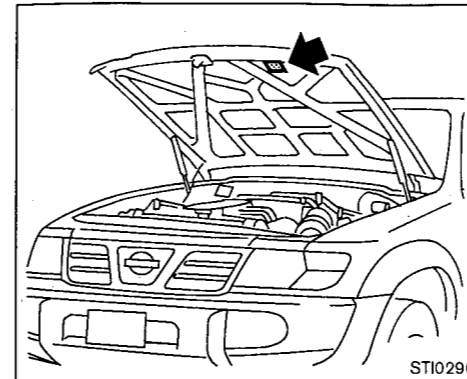

### AIR CONDITIONER SPECIFICATION LABEL (if so equipped)

This label is affixed to the underside of the engine hood as shown.

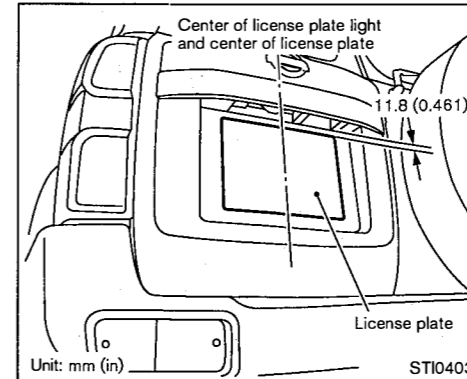

### REAR LICENSE PLATE (for Europe)

Install the license plate as shown for the proper visibility.

The upper edge of the license plate should be located 11.8 mm (0.461 in) below the lower edge of the finisher rubber of the back door handle.

### RADIO APPROVAL NUMBER AND INFORMATION (for Europe)

**SIEMENS**  
5WK4 8042  
f = 134.2 kHz  
Siemens AG  
93009 Regensburg  
NISSAN STEP 5.6

Siemens AG  
134 kHz  
Step 5.6



Siemens AG  
134 kHz  
5WK4 750



Siemens AG  
134 kHz  
5WK4 630



MCW 129/95 11/1998

STI0284

### FOR EUROPE

### NISSAN Anti-Theft System (NATS) immobilizer

Your vehicle is equipped with one of the immobilizer systems shown above.

See also NATS control unit additional approval numbers.

Siemens AG  
93049 Regensburg  
5WK4 865  
433,92 MHz

CEPT LPD-I  
nr.DGPGF/4/2/03/339175/  
SG/0001014 del 06/04/98

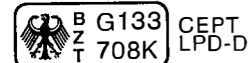

IRLTRA 24/5/60/49  
IS-2833-00  
CEPT LPD-DK 9802  
CEPT LPD-GR.YME  
SRD MPT 1340 GB  
Ue 980009  
RTT/D/X 1593  
MCW 129/95 29/1997  
ICP-010TC-98  
E D.G.TEL. 08 98 01 22  
BAKOM 98.0069.K.P  
Ref.No:3K43D/3R1B9/SPLS/RX-9/98

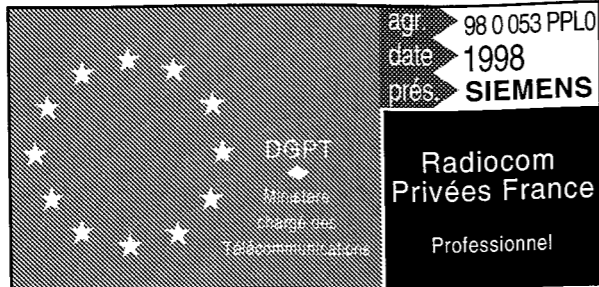

agr 98 0 053 PPL0  
date 1998  
prés SIEMENS

Radiocom  
Privées France  
Professionnel

ST10257

Remote keyless entry system

9-16 Technical information

# 10 Index

A	
Adjusting the time .....	2-35
Air bag	
Air bag warning labels .....	1-47
Air bag warning light .....	1-47
Driver air bag system .....	1-44
Front and side air bag system .....	1-38
Air cleaner filter .....	8-31
Air conditioner	
Air conditioner filter .....	4-6
Air conditioner specification label .....	9-15
Automatic air conditioner .....	4-10
Heater and air conditioner .....	4-6
Manual air conditioner .....	4-7
Servicing air conditioner .....	4-14
Air conditioning system refrigerant and lubricant recommendations .....	9-5
Aluminum alloy wheels .....	7-3
AM radio .....	4-18
Antenna .....	4-16
Anti-lock braking system (ABS) .....	5-34
Armrest .....	1-10
Ashtrays and cigarette lighter .....	2-37
Audible reminders .....	2-21
Audio operation precautions .....	4-15
Audio system .....	4-15
Automatic	
Automatic air conditioner .....	4-10
Automatic transmission .....	8-23
Automatic transmission fluid .....	8-23
Driving with automatic transmission... ..	5-11, 5-14

B	
Back door .....	3-17
Battery .....	5-35, 8-27
Before starting the engine .....	5-2
Bleeding the fuel system .....	8-22
Blocking wheels .....	6-5
Brake	
Brake and clutch fluid .....	8-25
Brake conditions .....	8-35
Brake precautions .....	5-33
Brake system .....	5-33
Checking brake pedal .....	8-35
Checking parking brake .....	8-35
Parking brake .....	3-24, 5-36
Trailer brakes .....	5-33
Break-in schedule .....	5-2
Built date plate .....	9-13

C	
Car phone or CB radio .....	4-53
Card holder .....	2-40
Care when driving .....	5-4
Cargo net .....	3-21
Center mark on seat belts .....	1-15
Changing	
Changing engine coolant .....	8-14
Changing engine oil .....	8-17
Changing engine oil filter .....	8-19
Changing wheels and tires .....	8-51
Checking brake pedal .....	8-35

Checking bulbs .....	2-16
Checking engine coolant level .....	8-14
Checking engine oil level .....	8-17
Checking parking brake .....	8-35
Checking water entry .....	8-51, 8-52
Child restraint	
Child restraint anchorage .....	1-37
Child restraints .....	1-21
Installation of child restraint system .....	1-26
Precautions on child restraints usage .....	1-21
Universal child restraints for front passenger seat and rear seats .....	1-23
Child safety .....	1-13
Child safety back door lock .....	3-19
Child safety rear door lock .....	3-8
Chrome parts .....	7-3
Cleaning exterior .....	7-3
Cleaning interior .....	7-3
Clock .....	2-34
<b>4x4</b> Clutch housing .....	8-51
Cold weather driving .....	5-35
Compact disc	
FM-AM radio with cassette tape player and compact disc (CD) changer .....	4-37
FM-AM radio with cassette tape player and compact disc (CD) player .....	4-25
LW-MW-FM radio with cassette tape player and compact disc (CD) changer .....	4-43
LW-MW-FW radio with compact disc (CD) player .....	4-31
Compass display .....	2-15
Console box .....	2-39
Cool box .....	4-14

Coolant	
Changing engine coolant .....	8-14
Checking engine coolant level.....	8-14
Engine coolant.....	5-36
Engine coolant temperature gauge.....	2-10
Corrosion protection .....	5-36, 7-5
Cruise control.....	5-27
Cruise control operations.....	5-28
Cup holders.....	2-42
Cyclone pre-air cleaner .....	8-33

## D

"DAY/NIGHT" button.....	4-4
Defogger switch.....	2-24
Dimensions .....	9-9
Display screen .....	4-2
Door locks.....	3-4
Double sun visor.....	3-25
Draining water.....	8-21
Drive belts.....	8-30
Driver air bag system .....	1-44

Driving	
Care when driving.....	5-4
Cold weather driving .....	5-35
<b>4x4</b> Driving four-wheel drive (4WD)	
safely.....	5-26
Driving in wet conditions.....	5-4
Driving in winter conditions.....	5-5
Driving vehicle .....	5-10
Driving with automatic transmission...	5-11, 5-14
Driving with manual transmission .....	5-10
Precautions when starting and driving .....	5-3

	<b>E</b>	
Engine.....		9-6
Before starting the engine.....		5-2
Changing engine coolant .....		8-14
Changing engine oil.....		8-17
Changing engine oil filter .....		8-19
Checking engine coolant level.....		8-14
Checking engine oil level .....		8-17
Engine cold start period.....		5-4
Engine compartment check locations.....		8-5
Engine coolant.....		5-36
Engine coolant temperature gauge.....		2-10
Engine cooling system .....		8-13
Engine oil.....		8-17
Engine serial number .....		9-13
Starting the engine .....		5-7
Environmental factors influence the rate of		
corrosion .....		7-5
Exhaust gas.....		5-3
Explanation of general maintenance items.....		8-2
Exterior lights.....		8-38

## F

Filter	
Air cleaner filter.....	8-31
Air conditioner filter .....	4-6
Changing engine oil filter .....	8-19
Fuel filter .....	8-21
Fire extinguisher.....	6-10
Flat tire.....	6-2
Fluid	
Automatic transmission fluid.....	8-23
Brake and clutch fluid .....	8-25
Power steering fluid .....	8-24
Window washer fluid.....	8-26

FM-AM radio.....	4-19
FM-AM radio with cassette tape player and	
compact disc (CD) changer.....	4-37
FM-AM radio with cassette tape player and	
compact disc (CD) player.....	4-25
FM-AM/MW-SW-FM radio with cassette tape	
player .....	4-23
Fog light switch .....	2-29
<b>4x4</b> Four-wheel drive .....	5-18
Front and side air bag system.....	1-38
Front fog lights.....	2-29
Front seats.....	1-3
Front ventilators.....	4-5
Fuel	
Bleeding the fuel system.....	8-22
Fuel filler cap.....	3-16, 3-17
Fuel filler lid.....	3-15
Fuel filter .....	8-21
Fuel gauge.....	2-11
Fuel recommendation.....	9-4
Opening fuel filler lid .....	3-15
Recommended fuel/lubricants and	
capacities.....	9-2
Sub fuel tank transfer switch.....	2-31
Fuses.....	8-35

## G

Gauge	
Engine coolant temperature gauge.....	2-10
Fuel gauge.....	2-11
Meters and gauges.....	2-8
General maintenance.....	8-2
Glass.....	7-2, 7-4
Glove box .....	2-39

## H

Hazard warning flasher switch.....	2-31
Head restraints .....	1-10
Headlight	
Headlight aiming control switch.....	2-27
Headlight and turn signal switch.....	2-25
Headlight cleaner switch .....	2-29
Headlight switch .....	2-27
Headlights.....	8-38
Xenon headlights.....	2-25
Heat switch.....	4-12
Heated seats .....	2-33
Heater and air conditioner.....	4-6
Hood.....	3-15
Hooks .....	3-21
Horn.....	2-31

## I

If your vehicle overheats.....	6-10
Ignition switch.....	5-5
Indicator lights.....	2-19
Injured persons .....	1-15
Inside rearview mirror.....	3-25
Installation of child restraint system .....	1-26
Installing spare tire .....	6-7
Instrument brightness control .....	2-12
Instrument center box .....	2-39
Instrument panel.....	2-2
Integrated key fob/remote control system.....	3-10
Interior lights .....	2-47, 8-39

## J

Jump starting.....	6-8
--------------------	-----

## K

Key positions.....	5-6
Keys.....	3-2
Knuckle flange.....	8-52

## L

Light	
Air bag warning light .....	1-47
Exterior lights .....	8-38
Fog light switch.....	2-29
Front fog lights.....	2-29
Headlight aiming control switch .....	2-27
Headlight and turn signal switch.....	2-25
Headlight cleaner switch .....	2-29
Headlight switch.....	2-27
Headlights.....	8-38
Indicator lights .....	2-19
Interior lights.....	2-47, 8-39
Light location .....	8-40
Lights .....	8-38
Personal light.....	2-48
Rear fog light.....	2-30
Room light.....	2-47
Vanity mirror light.....	2-49
Warning lights .....	2-16
Warning/indicator lights and audible	
reminders .....	2-16
Xenon headlights.....	2-25

Loading luggage .....	5-4
Lock	
Anti-lock braking system (ABS).....	5-34
Blocking wheels .....	6-5
Child safety back door lock.....	3-19
Child safety rear door lock .....	3-8
Door locks.....	3-4

Locking back door.....	3-18
Locking with inside lock knob .....	3-6
Locking with key.....	3-5
Locking with power door lock switch.....	3-7
Manual-lock free-running hubs .....	5-24
Rear differential lock-up switch .....	2-32
Super lock system .....	3-4
Two-way lock free-running hubs .....	5-21
Luggage hooks .....	3-22
Luggage side finisher hook .....	3-21
LW-MW-FM radio with cassette tape player	
and compact disc (CD) changer .....	4-43
LW-MW-FW radio with compact disc (CD)	
player .....	4-31

## M

Maintenance	
Explanation of general maintenance items .....	8-2
General maintenance.....	8-2
Maintenance precautions.....	8-3
Maintenance requirements.....	8-2
Seat belt maintenance.....	1-21
Manual air conditioner.....	4-7
Manual transmission.....	5-5
Manual windows.....	2-43
Manual-lock free-running hubs .....	5-24
Maximum load limits .....	5-31
Meters and gauges .....	2-8
Mirror	
Inside rearview mirror .....	3-25
Mirrors.....	3-25
Outside rearview mirrors .....	3-26
Vanity mirror light.....	2-49
Most common factors contributing to vehicle	
corrosion .....	7-5
MW-SW radio with cassette tape player.....	4-21

**N**

NISSAN Anti-Theft System (NATS)... 3-3, 3-13, 5-6

**O****Oil**

Changing engine oil.....	8-17
Changing engine oil filter.....	8-19
Checking engine oil level.....	8-17
Engine oil.....	8-17
Opening back door.....	3-18
Opening fuel filler lid.....	3-15
Operating precautions.....	5-31
Outside rearview mirrors.....	3-26
Outside temperature display.....	2-13
Outside temperature display and compass.....	2-13
Overheat	
If your vehicle overheats.....	6-10

**P**

Parking.....	5-29
Checking parking brake.....	8-35
Parking brake.....	3-24, 5-36
Personal light.....	2-48
Pintle hook.....	6-12
Plastic parts.....	7-4
Platinum-tipped spark plug.....	8-31
Power	
Locking with power door lock switch.....	3-7
Power outlet.....	2-38
Power steering fluid.....	8-24
Power windows.....	2-44
Precautions	
Audio operation precautions.....	4-15

Brake precautions.....	5-33
Maintenance precautions.....	8-3
Operating precautions.....	5-31
Precautions on child restraints usage.....	1-21
Precautions on cruise control.....	5-29
Precautions on seat belt usage.....	1-11
Precautions on winch.....	5-37
Precautions when starting and driving.....	5-3
Safety precautions.....	4-2
Towing precautions.....	6-11
Pregnant women.....	1-14
Preparing tools and spare tire.....	6-2
Protect the environment.....	8-21
Push starting.....	6-9

**R**

Radio	
AM radio.....	4-18
Car phone or CB radio.....	4-53
FM-AM radio.....	4-19
FM-AM radio with cassette tape player and compact disc (CD) changer.....	4-37
FM-AM radio with cassette tape player and compact disc (CD) player.....	4-25
FM-AM/MW-SW-FM radio with cassette tape player.....	4-23
LW-MW-FM radio with cassette tape player and compact disc (CD) changer.....	4-43
LW-MW-FW radio with compact disc (CD) player.....	4-31
MW-SW radio with cassette tape player.....	4-21
Radio approval number and information.....	9-15
Rear cooler.....	4-13
Rear differential lock-up switch.....	2-32
Rear fog light.....	2-30
Rear heater.....	4-13
Rear license plate.....	9-15

Rear seats.....	1-6
Rear stabilizer release switch.....	2-33
Rear ventilators.....	4-6
Rear window wiper and washer switch.....	2-23
Recommended fuel/lubricants and capacities.....	9-2
Recommended SAE viscosity number.....	9-4
Remote controller battery.....	8-28
Remote keyless entry system.....	3-8
Removing spots.....	7-2
Removing the tire.....	6-5
Replacing spark plugs.....	8-31
Resetting the time.....	2-36
Roof rack.....	3-23
Room light.....	2-47

**S**

Safety	
Child safety.....	1-13
Child safety back door lock.....	3-19
Child safety rear door lock.....	3-8
Safety chains.....	5-33
Safety precautions.....	4-2
Seat	
3rd seats.....	1-8
Center mark on seat belts.....	1-15
Front seats.....	1-3
Heated seats.....	2-33
Precautions on seat belt usage.....	1-11
Rear seats.....	1-6
Seat belt maintenance.....	1-21
Seat belts.....	1-11, 7-4
Seatback tray.....	2-40
Seats.....	1-2
Three-point type seat belts.....	1-15
Two-point type seat belts.....	1-20

Universal child restraints for front passenger seat and rear seats.....	1-23
Seat belt	
Center mark on seat belts.....	1-15
Precautions on seat belt usage.....	1-11
Seat belt maintenance.....	1-21
Seat belts.....	1-11, 7-4
Three-point type seat belts.....	1-15
Two-point type seat belts.....	1-20
Security system.....	3-12
Servicing air conditioner.....	4-14
Spark plugs.....	8-31
Special winter equipment.....	5-36
Speedometer and odometer.....	2-8
Starting	
Before starting the engine.....	5-2
Jump starting.....	6-8
Precautions when starting and driving.....	5-3
Push starting.....	6-9
Starting the engine.....	5-7
Steering	
Power steering fluid.....	8-24
Steering switch for audio control.....	4-51
Steering wheel.....	3-24
Stopping the vehicle.....	6-2
Storage.....	2-38
Stowing the damaged tire and tools.....	6-8
Sub fuel tank transfer switch.....	2-31
Sun visors.....	3-25
Sunglasses holder.....	2-41
Sunroof.....	2-46
Super lock system.....	3-4
Supplemental restraint system.....	1-38
Switch	
Fog light switch.....	2-29
Hazard warning flasher switch.....	2-31
Headlight aiming control switch.....	2-27
Headlight and turn signal switch.....	2-25

Headlight cleaner switch.....	2-29
Headlight switch.....	2-27
Heat switch.....	4-12
Ignition switch.....	5-5
Locking with power door lock switch.....	3-7
Rear differential lock-up switch.....	2-32
Rear stabilizer release switch.....	2-33
Rear window wiper and washer switch.....	2-23
Steering switch for audio control.....	4-51
Sub fuel tank transfer switch.....	2-31
Turn signal switch.....	2-27
Windshield deicer switch.....	2-25
Windshield wiper and washer switch.....	2-22
Wiper and washer switch.....	2-22

**T**

Tachometer.....	2-9
Tailgate.....	3-23
Theft warning.....	3-12
Three way catalyst.....	5-3
Tilt operation.....	3-24
Timing chain/gear.....	9-6
Tire	
Changing wheels and tires.....	8-51
Flat tire.....	6-2
Installing spare tire.....	6-7
Preparing tools and spare tire.....	6-2
Removing the tire.....	6-5
Stowing the damaged tire and tools.....	6-8
Tire age.....	8-50
Tire chains.....	8-49
Tire equipment.....	5-36
Tire inflation pressure.....	8-48
Tire placard.....	9-14
Tire pressure.....	5-33
Tire rotation.....	8-50

Tire wear and damage.....	8-50
Tires and wheels.....	8-48, 9-8
4x4 Tires for four-wheel drive (4WD) model.....	8-51
4x4 Tires of four-wheel drive.....	5-27
Types of tires.....	8-48
To protect your vehicle from corrosion.....	7-5
Tonneau cover.....	3-19
Towing	
Stowing the damaged tire and tools.....	6-8
Towing point.....	6-12
Towing precautions.....	6-11
Towing recommended by NISSAN.....	6-11
Towing your vehicle.....	6-11
Trailer towing.....	5-31
Trailer brakes.....	5-33
Trailer towing.....	5-31
Transfer case shifting procedures.....	5-18
Transmission	
Automatic transmission.....	5-6
Automatic transmission fluid.....	8-23
Driving with automatic transmission.....	5-11, 5-14
Driving with manual transmission.....	5-10
Manual transmission.....	5-5
Turbocharger system.....	5-4
Turn signal switch.....	2-27
Two-way lock free-running hubs.....	5-21
Types of tires.....	8-48

**U**

Underbody.....	7-3
Universal child restraints for front passenger seat and rear seats.....	1-23
Using integrated keyfob/remote control system.....	3-11
Using remote keyless entry system.....	3-9

**V**

Vanity mirror light ..... 2-49  
 Vehicle battery ..... 8-27  
 Vehicle identification ..... 9-12  
     Vehicle identification number ..... 9-13  
     Vehicle identification number plate ..... 9-12  
     Vehicle identification plate ..... 9-12  
 Vehicle security ..... 5-33  
 Ventilators ..... 4-5

**W**

Wagon and hardtop models ..... 2-2  
 Warning  
     Air bag warning labels ..... 1-47  
     Air bag warning light ..... 1-47  
     Hazard warning flasher switch ..... 2-31  
     Theft warning ..... 3-12  
     Warning lights ..... 2-16  
     Warning/indicator lights and audible reminders ..... 2-16  
 Washer switch  
     Rear window wiper and washer switch ..... 2-23  
     Windshield wiper and washer switch ..... 2-22  
     Wiper and washer switch ..... 2-22  
 Washing ..... 7-2  
 Waxing ..... 7-2  
 Wheel balance ..... 8-51  
 Wheels ..... 7-3  
 When travelling or registered in another country ..... 9-12  
 Winch ..... 5-37  
 Winch operation ..... 5-38  
 Window  
     Manual windows ..... 2-43  
     Power windows ..... 2-44

Rear window wiper and washer switch ..... 2-23  
 Window washer fluid ..... 8-26  
 Windows ..... 2-43  
 Windshield deicer switch ..... 2-25  
 Windshield wiper and washer switch ..... 2-22  
 Wiper  
     Rear window wiper and washer switch ..... 2-23  
     Windshield wiper and washer switch ..... 2-22  
     Wiper and washer switch ..... 2-22  
     Wiper blades ..... 8-34

**X**

Xenon headlights ..... 2-25

**GAS STATION INFORMATION**

**RECOMMENDED FUEL**

Gasoline engine

Models equipped with three way catalyst:

Unleaded gasoline of 91 octane (RON) or above

**CAUTION:**

**Do not use leaded gasoline. Using leaded gasoline will damage the three way catalyst.**

Models not equipped with three way catalyst:

Unleaded or leaded gasoline of 91 octane (RON) or above

Use unleaded fuel if instructed on the fuel filler lid.

Diesel engine\*

Diesel fuel of above 45 cetane for TD42 and TD42Ti engines and at least 50 cetane for ZD30DDTi engine

\*: For further details, see "Fuel recommendation" in the "9. Technical information" section.

**RECOMMENDED ENGINE OIL**

Gasoline engine

Genuine NISSAN engine oil

**For Europe:**

API grade SE, SF, SG, SH, SJ, SL or SM  
 ACEA A2 or A3  
 ILSAC grade GF-1, GF-2, GF-3, GF-4 or SG+

**Except Europe:**

API grade SE, SF, SG, SH, SJ, SL or SM  
 ILSAC grade GF-1, GF-2, GF-3, GF-4 or SG+

Diesel engine

Genuine NISSAN engine oil

**TD42 and TD42Ti engines:**

API grade CC, CD, CE, CF or CF-4\*  
 JASO DH-1

\*For Pickup models for South Africa: API grade CF-4 or JASO DH-1 only

**ZD30DDTi engine:**

For Europe ... API grade CF-4 (Never use API CG-4 oil.), ACEA B3 or B3/E3 or JASO DH-1

Except for Europe ... API grade CE, CF or CF-4 (Never use API CG-4 oil.), JASO DH-1

For further details, see "Recommended SAE

viscosity number" in the "9. Technical information" section.

**TIRE COLD PRESSURE**

See tire placard affixed to the glove box or driver side center pillar.



## QUICK REFERENCE

(page)

- In case of emergency ..... 6-1  
(Flat tire, engine will not start,  
overheating, towing)
- How to start the engine ..... 5-1
- How to read the meters and  
gauges ..... 2-1
- Maintenance and do-it-yourself ..... 8-1
- Technical information ..... 9-1

## SECURITY INFORMATION

As the owner of this vehicle, a number of important codes have been supplied to you that you may require in case your radio needs to be repaired or in case you need to duplicate a NATS key.

Please fill in the allocated areas for the radio security code (if so equipped) and key code. See "AUDIO SYSTEM" in the "4. Display screen, heater and air conditioner, and audio system" section for information about the radio security code. For the key code, see "KEYS" in the "3. Pre-driving checks and adjustments" section. Remove the page from this manual and keep it in a safe place, **not in the vehicle.**

When selling your vehicle, we kindly request you to hand over the page to the buyer.

## SECURITY INFORMATION

Radio security code  
(if so equipped)

--	--	--	--

Key code

--	--	--	--	--

Remove the page from the manual and keep it in a safe place, **not in the vehicle.**

When selling your vehicle, we kindly request you to hand over this page to the buyer.