

SECTION **BRM**  
BODY REPAIR

A  
B  
C  
D  
E  
F  
G  
H  
I  
J  
L  
M  
N  
O  
P

CONTENTS

<b>REGULAR GRADE</b>	
<b>VEHICLE INFORMATION</b> .....	2
<b>BODY EXTERIOR PAINT COLOR</b> .....	2
Body Exterior Paint Color .....	2
<b>PRECAUTION</b> .....	3
<b>REPAIRING HIGH STRENGTH STEEL</b> .....	3
High Strength Steel (HSS) .....	3
Handling of Ultra High Strength Steel Plate Parts.....	5
<b>PREPARATION</b> .....	6
<b>REPAIRING MATERIAL</b> .....	6
Foam Repair .....	6
<b>BODY COMPONENT PARTS</b> .....	8
Underbody Component Parts .....	8
Body Component Parts .....	10
<b>REMOVAL AND INSTALLATION</b> .....	12
<b>CORROSION PROTECTION</b> .....	12
Description .....	12
Undercoating .....	12
Stone Guard Coat .....	13
Body Sealing .....	14
<b>BODY CONSTRUCTION</b> .....	18
Body Construction .....	18
Rear Fender Hemming Process .....	19
<b>REPLACEMENT OPERATIONS</b> .....	21
Description .....	21
Radiator Core Support .....	23
Hoodledge .....	23
Hoodledge (Partial Replacement) .....	25
Front Side Member .....	27
Front Side Member (Partial Replacement) .....	29
Front Pillar .....	30
Center Pillar .....	33
Outer Sill (Partial Replacement) .....	37
Outer Sill .....	38
Rear Fender (LH) .....	41
Rear Fender (RH) .....	45
Rear Panel .....	49
Rear Floor Rear .....	49
Rear Side Member Extension .....	50
<b>SERVICE DATA AND SPECIFICATIONS (SDS)</b> .....	52
<b>BODY ALIGNMENT</b> .....	52
Body Center Marks .....	52
Description .....	53
Engine Compartment .....	53
Underbody .....	55
Passenger Compartment .....	58
Rear Body .....	60
<b>LOCATION OF PLASTIC PARTS</b> .....	62
Precautions for Plastics .....	62
Location of Plastic Parts .....	63
<b>Krom</b>	
<b>SPEC CHANGE INFORMATION</b> .....	65
<b>BODY EXTERIOR PAINT COLOR</b> .....	65
Body Exterior Paint Color (Krom) .....	65
<b>SERVICE DATA AND SPECIFICATIONS (SDS)</b> .....	66
<b>LOCATION OF PLASTIC PARTS</b> .....	66
Precautions for Plastics .....	66
Location of Plastic Parts (Krom) .....	67

BRM

# BODY EXTERIOR PAINT COLOR

< VEHICLE INFORMATION >

[REGULAR GRADE]

## VEHICLE INFORMATION

### BODY EXTERIOR PAINT COLOR

#### Body Exterior Paint Color

INFOID:000000005094276

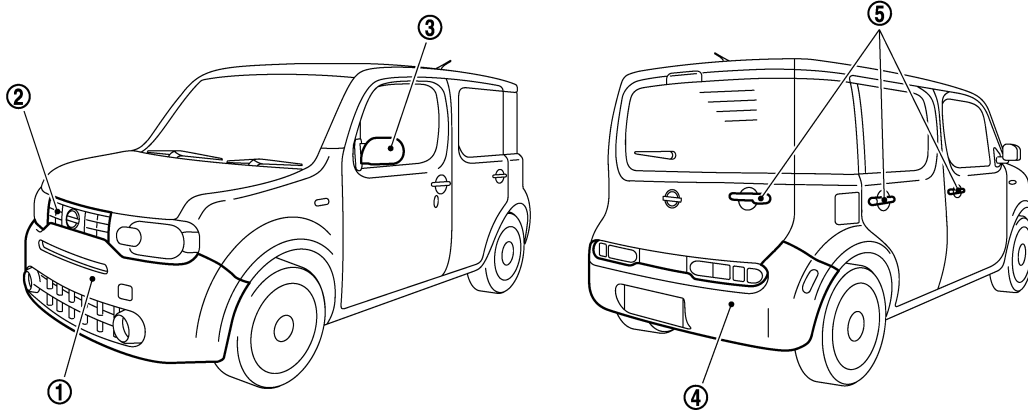

JSKIA1176ZZ

Component		Color code	BAY4	BJAC*	BKH3	BKY0	BK21	BL50*	BQX1	BRAH*	
		Description	Red	Yellowish Green	Black	Silver	Gray	Brownish Purple	White	Blue	
		Paint type <sup>note</sup>	PM	PM	2S	M	FPM	P	3P	PM	
		Hard clear coat	-	-	-	-	-	-	-	-	-
1	Front bumper fascia	Body color	BAY4	BJAC	BKH3	BKY0	BK21	BL50	BQX1	BRAH	
2	Front grille	Dark Gray	LX15	LX15	LX15	LX15	LX15	LX15	LX15	LX15	
3	Door outside mirror	Cover	Body color	BAY4	BJAC	BKH3	BKY0	BK21	BL50	BQX1	BRAH
			Material color	-	-	-	-	-	-	-	-
4	Rear bumper fascia	Body color	BAY4	BJAC	BKH3	BKY0	BK21	BL50	BQX1	BRAH	
5	Door outside handle	Body color	BAY4	BJAC	BKH3	BKY0	BK21	BL50	BQX1	BRAH	

**NOTE:**

- 2S: Solid + Clear
  - CS: Color clear solid
  - M: Metallic
  - P: 2-Coat pearl
  - 3P: 3-Coat pearl
  - FPM: Iron oxide pearl
  - RPM: Multi flex color
  - TPM: Titanium pearl metallic
  - TM: Micro titanium metallic
  - PM: Pearl metallic
- \*: Except for standard grade for USA

PRECAUTION

REPAIRING HIGH STRENGTH STEEL

High Strength Steel (HSS)

INFOID:000000005094277

High strength steel is used for body panels in order to reduce vehicle weight. Accordingly, precautions in repairing automotive bodies made of high strength steel are described below:

Tensile strength	Major applicable parts
370 - 590 MPa	<ul style="list-style-type: none"> <li>• Front strut housing</li> <li>• Side dash</li> <li>• Lower dash crossmember assembly</li> <li>• Lower dash crossmember reinforcement (Component part)</li> <li>• Center front floor</li> <li>• 2nd and 3rd crossmember (Front floor component part)</li> <li>• Front side member assembly</li> <li>• Front side member closing plate assembly</li> <li>• Front suspension mounting bracket</li> <li>• Rear seat crossmember</li> <li>• Center rear crossmember assembly</li> <li>• Rear side member assembly</li> <li>• Front pillar brace</li> <li>• Center pillar reinforcement</li> <li>• Inner side roof rail complete</li> <li>• Inner center pillar</li> <li>• Inner rear pillar (Component part)</li> <li>• Lower inner rear pillar</li> <li>• Back pillar assembly (Component part)</li> <li>• Rear panel assembly (Component part)</li> <li>• Front side member front assembly</li> <li>• Rear bumper stay</li> <li>• Other reinforcements</li> </ul>
780 - 1350 MPa	<ul style="list-style-type: none"> <li>• Inner sill</li> <li>• Front side member rear extension (Front floor component part)</li> <li>• Outer side roof rail reinforcement</li> <li>• Outer sill reinforcement</li> <li>• Inner center rear bumper reinforcement assembly</li> </ul>

A  
B  
C  
D  
E  
F  
G  
H  
I  
J  
BRM

Read the following precautions when repairing HSS:

- Additional points to consider
  - The repair of reinforcements (such as side members) by heating is not recommended, because it may weaken the component. When heating is unavoidable, never heat HSS parts above 550°C (1,022°F). Verify heating temperature with a thermometer. (Crayon-type and other similar type thermometer are appropriate.)

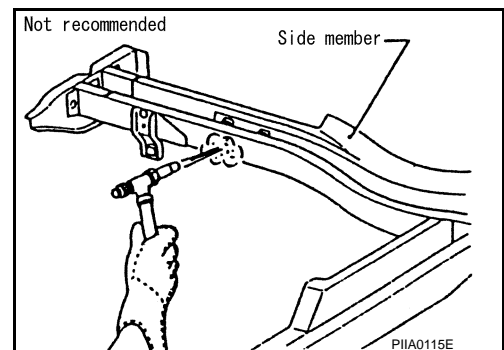

L  
M  
N  
O  
P

# REPAIRING HIGH STRENGTH STEEL

[REGULAR GRADE]

## < PRECAUTION >

- When straightening body panels, use caution in pulling any HSS panel. Because HSS is very strong, pulling may cause deformation in adjacent sections of the body. In this case, increase the number of measuring points, and carefully pull the HSS panel.
- When cutting HSS panels, avoid gas (torch) cutting if possible. Instead, use a saw to avoid weakening surrounding areas due to heat. If gas (torch) cutting is unavoidable, allow a minimum margin of 50 mm (1.97 in).

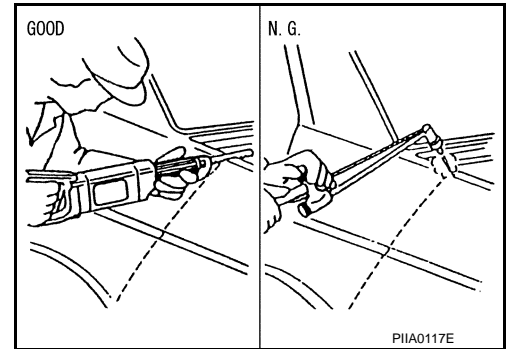

- When welding HSS panels, use spot welding whenever possible in order to minimize weakening surrounding areas due to heat. If spot welding is impossible, use MIG. welding. Do not use gas (torch) for welding because it is inferior in welding strength.

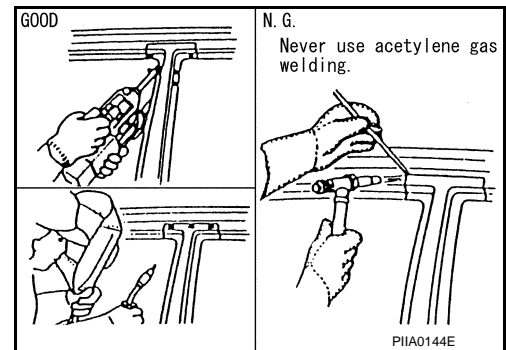

- Spot welding on HSS panels is harder than that of an ordinary steel panel. Therefore, when cutting spot welds on a HSS panel, use a low speed high torque drill (1,000 to 1,200 rpm) to increase drill bit durability and facilitate the operation.

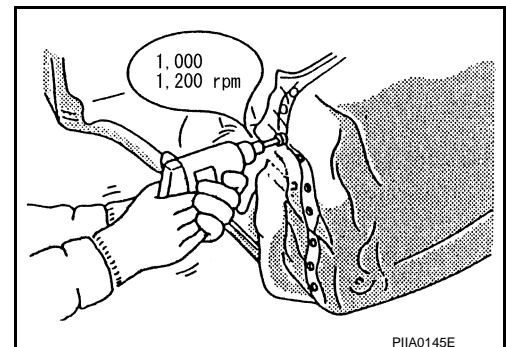

## 2. Precautions in spot welding HSS

This work should be performed under standard working conditions. Always note the following when spot welding HSS:

- The electrode tip diameter must be sized properly according to the metal thickness.

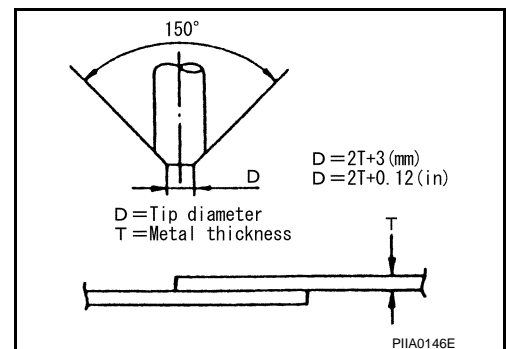

# REPAIRING HIGH STRENGTH STEEL

[REGULAR GRADE]

## < PRECAUTION >

- The panel surfaces must fit flush to each other, leaving no gaps.

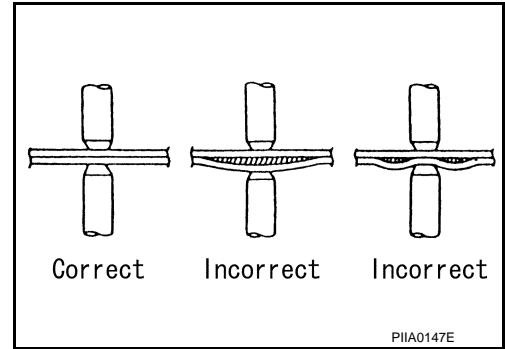

- Follow the specifications for the proper welding pitch.

Unit: mm (in)

Thickness (T)	Minimum pitch (L)
0.6 (0.024)	10 (0.39) or more
0.8 (0.031)	12 (0.47) or more
1.0 (0.039)	18 (0.71) or more
1.2 (0.047)	20 (0.79) or more
1.6 (0.063)	27 (1.06) or more
1.8 (0.071)	31 (1.22) or more

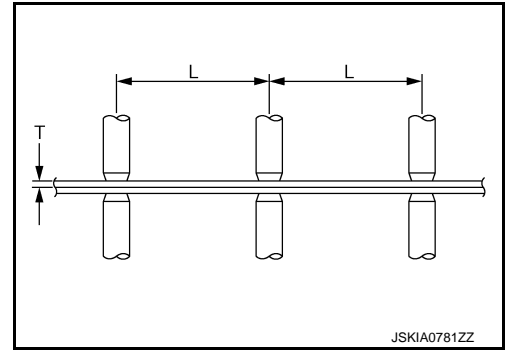

## Handling of Ultra High Strength Steel Plate Parts

INFOID:000000005094278

### PROHIBITION OF CUT AND CONNECTION

Never cut and joint the lower lock pillar reinforcement (center pillar reinforcement inside frame parts) because its material is high strength steel plate (ultra high strength steel plate). The center pillar reinforcement must be replaced if this part is damaged.

A  
B  
C  
D  
E  
F  
G  
H  
I  
J

BRM

L  
M  
N  
O  
P

**PREPARATION**

**REPAIRING MATERIAL**

**Foam Repair**

INFOID:000000005094279

During factory body assembly, foam insulators are installed in certain body panels and locations around the vehicle. Use the following procedure(s) to replace any factory-installed foam insulators.

**URETHANE FOAM APPLICATIONS**

Use commercially available Urethane foam for sealant (foam material) repair of material used on vehicle.

**<Urethane foam for foaming agent>**

**3M™ Automix™ Flexible Foam 08463 or equivalent**

Read instructions on product for fill procedures.

Example of foaming agent filling operation procedure

1. Fill procedures after installation of service part.
  - a. Eliminate foam material remaining on vehicle side.
  - b. Clean area after eliminating form insulator and foam material.
  - c. Install service part.
  - d. Insert nozzle into hole near fill area and fill foam material or fill enough to close gap with the service part.

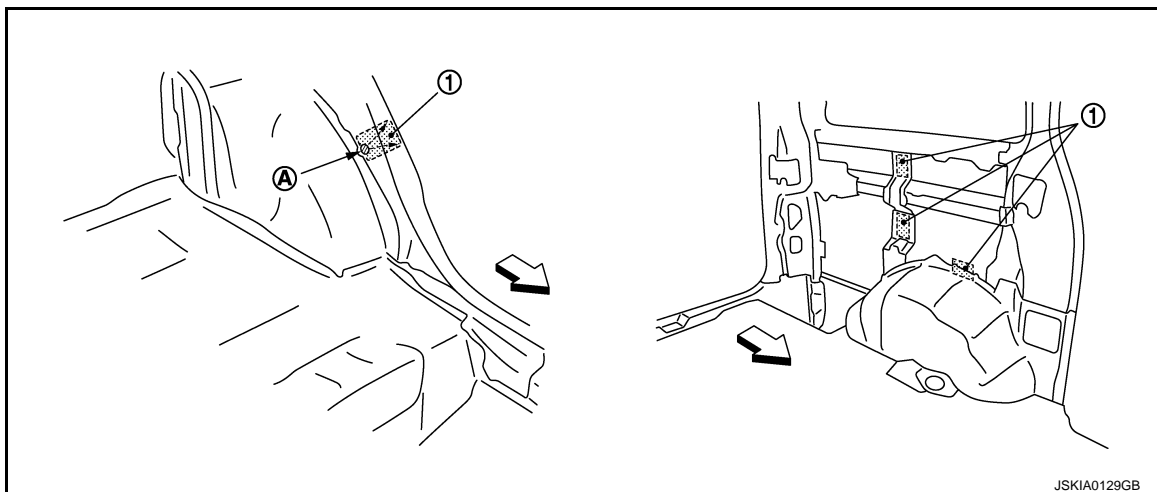

- 1. Urethane foam
- A. Nozzle insert hole
- ↙: Vehicle front

2. Fill procedures before installation of service part.
  - a. Eliminate foam material remaining on vehicle side.
  - b. Clean area after eliminating foam insulator and foam material.
  - c. Fill foam material on wheelhouse outer side.

# REPAIRING MATERIAL

< PREPARATION >

[REGULAR GRADE]

- 1. Urethane foam
- A. Fill while avoiding flange area

←: Vehicle front

**NOTE:**

Fill enough to close gap with service part while avoiding flange area.

- d. Install service part.

**NOTE:**

Refer to label for information on working times.

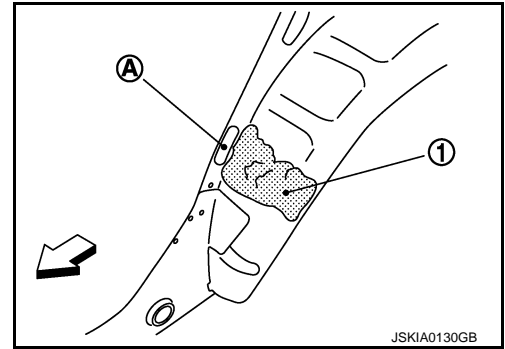

A  
B  
C  
D  
E  
F  
G  
H  
I  
J  
L  
M  
N  
O  
P

BRM

# BODY COMPONENT PARTS

< PREPARATION >

[REGULAR GRADE]

## BODY COMPONENT PARTS

### Underbody Component Parts

INFOID:000000005094280

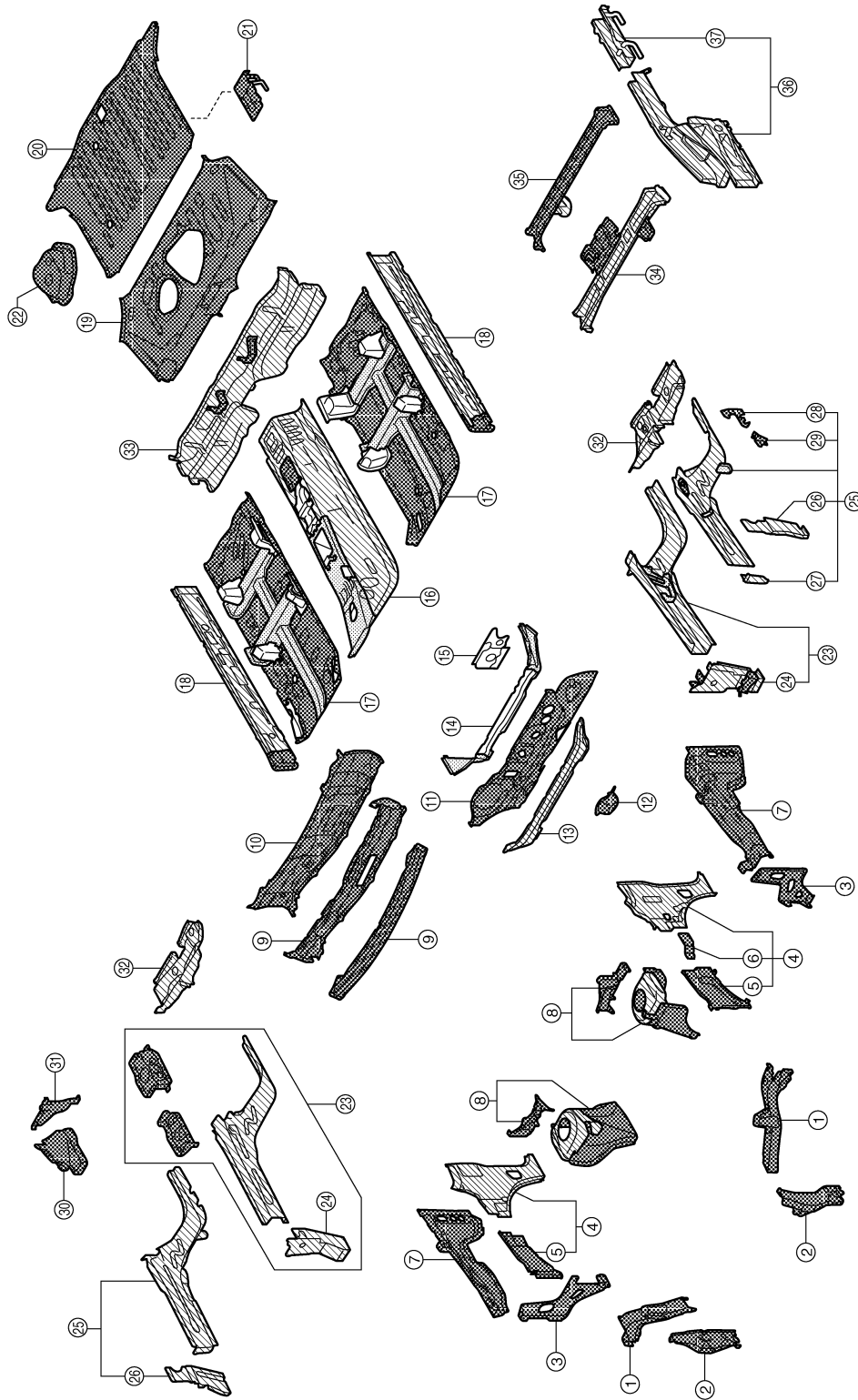

JSKIA117ZZ

- |   |   |                                   |
|---|---|-----------------------------------|
| 1. Side radiator core support (RH & LH) | 2. Side radiator core reinforcement (RH & LH) | 3. Hoodledge connector (RH & LH)  |
| 4. Side dash (RH & LH)                  | 5. Upper hoodledge (RH & LH)                  | 6. Hoodledge reinforcement gusset |



# BODY COMPONENT PARTS

< PREPARATION >

[REGULAR GRADE]

- |  |   |  |   |
|--|---|--|---|
| 7. Hoodledge reinforcement (RH & LH)                   | 8. Front strut housing (RH & LH)                | 9. Cowl top                              |   |
| 10. Upper dash assembly                                | 11. Lower dash                                  | 12. Steering hole patch                  | A |
| 13. Lower dash crossmember assembly                    | 14. Lower dash crossmember reinforcement        | 15. Lower dash reinforcement             |   |
| 16. Center front floor                                 | 17. Front floor (RH & LH)                       | 18. Inner sill (RH & LH)                 | B |
| 19. Rear floor front                                   | 20. Rear floor rear                             | 21. Center rear member assembly          |   |
| 22. Rear floor rear cover                              | 23. Front side member assembly (RH & LH)        | 24. Outer add on frame bracket (RH & LH) | C |
| 25. Front side member closing plate assembly (RH & LH) | 26. Add on frame bracket (RH & LH)              | 27. Tie down hook reinforcement          |   |
| 28. Front side closing plate reinforcement             | 29. Front side rear closing reinforcement       | 30. Lower front hoodledge                | D |
| 31. Strut housing reinforcement                        | 32. Front suspension mounting bracket (RH & LH) | 33. Rear seat crossmember                |   |
| 34. Center rear crossmember assembly                   | 35. 7th crossmember                             | 36. Rear side member assembly (RH & LH)  | E |
| 37. Rear side member extension (RH & LH)               |   |  | F |

 Both sided anti-corrosive precoated steel sections

 High strength steel (HSS) sections

 Both sided anti-corrosive steel and HSS sections

**NOTE:**

For the parts without a number described in the figure, it is supplied only with the assembly part that the part is included with.

A  
B  
C  
D  
E  
F  
G  
H  
I  
J  
L  
M  
N  
O  
P

**BRM**

# BODY COMPONENT PARTS

< PREPARATION >

[REGULAR GRADE]

## Body Component Parts

INFOID:000000005094281

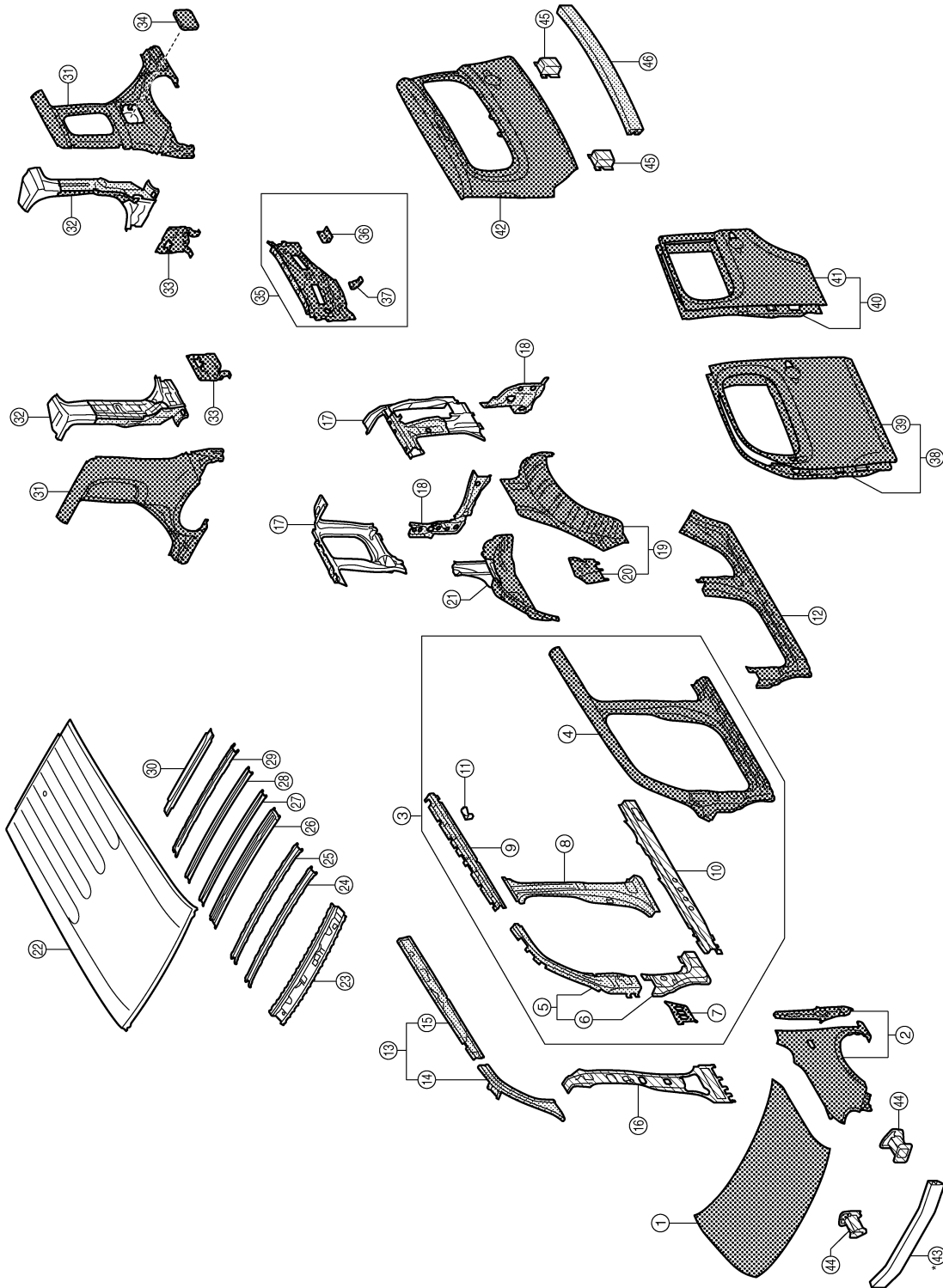

JSKIA1178ZZ

- |   |  |   |
|---|--|---|
| 1. Hood                                       | 2. Front fender (RH & LH)                | 3. Side body assembly (RH & LH)                 |
| 4. Outer front side body (RH & LH)            | 5. Front pillar brace (RH & LH)          | 6. Lower front pillar hinge brace (RH & LH)     |
| 7. Lower front pillar reinforcement (RH & LH) | 8. Center pillar reinforcement (RH & LH) | 9. Outer side roof rail reinforcement (RH & LH) |

# BODY COMPONENT PARTS

< PREPARATION >

[REGULAR GRADE]

- |   |  |  |   |
|---|--|--|---|
| 10. Outer sill reinforcement (RH & LH)              | 11. Seat belt anchor reinforcement             | 12. Outer sill (RH & LH)                           |   |
| 13. Inner side roof rail complete (RH & LH)         | 14. Upper inner front pillar (RH & LH)         | 15. Inner side roof rail (RH & LH)                 | A |
| 16. Inner center pillar (RH & LH)                   | 17. Inner rear pillar (RH & LH)                | 18. Lower inner rear pillar (RH & LH)              |   |
| 19. Outer rear wheelhouse (RH & LH)                 | 20. Outer rear wheelhouse extension (RH & LH)  | 21. Inner rear wheelhouse (RH & LH)                | B |
| 22. Roof  | 23. Front roof rail                            | 24. Roof bow No. 1                                 |   |
| 25. Roof bow No. 2                                  | 26. Center roof reinforcement                  | 27. Roof bow No. 3                                 | C |
| 28. Roof bow No. 4                                  | 29. Roof bow No. 5                             | 30. Rear roof rail                                 |   |
| 31. Rear fender assembly (RH & LH)                  | 32. Back pillar assembly (RH & LH)             | 33. Rear combination lamp base extension (RH & LH) | D |
| 34. Fuel filler lid                                 | 35. Rear panel assembly                        | 36. Upper rear bumper retainer                     |   |
| 37. Rear side bumper bracket                        | 38. Front door assembly (RH & LH)              | 39. Outer front door panel (RH & LH)               | E |
| 40. Rear door assembly (RH & LH)                    | 41. Outer rear door panel (RH & LH)            | 42. Back door                                      |   |
| 43. Front bumper armature assembly                  | 44. Front side member front assembly (RH & LH) | 45. Rear bumper stay (RH & LH)                     | F |
| 46. Inner center rear bumper reinforcement assembly |  |  |   |

 Both sided anti-corrosive pre-coated steel sections

 High strength steel (HSS) sections

 Both sided anti-corrosive steel and HSS sections

\*: Aluminum portion

**NOTE:**

For the parts without a number described in the figure, it is supplied only with the assembly part that the part is included with.

A  
B  
C  
D  
E  
F  
G  
H  
I  
J  
L  
M  
N  
O  
P

**BRM**

## REMOVAL AND INSTALLATION

### CORROSION PROTECTION

#### Description

INFOID:000000005094290

To provide improved corrosion prevention, the following anti-corrosive measures have been implemented in NISSAN production plants. When repairing or replacing body panels, it is necessary to use the same anti-corrosive measures.

#### Anti-Corrosive Precoated Steel (Galvannealed Steel)

To improve reparability and corrosion resistance, a new type of anti-corrosive precoated steel sheet is adopted replacing conventional zinc-coated steel sheet.

Galvannealed steel is electroplated and heated to form Zinc-iron alloy, which provides excellent and long term corrosion resistance with cationic electrodeposition primer.

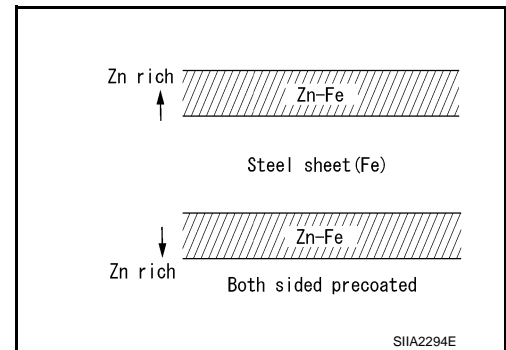

NISSAN genuine parts are fabricated from galvannealed steel. Therefore, it is recommended that NISSAN genuine parts or an equivalent be used for panel replacement to maintain the anti-corrosive performance built into the vehicle at the factory.

#### Phosphate Coating Treatment and Cationic Electrodeposition Primer

A phosphate coating treatment and a cationic electrodeposition primer, which provide excellent corrosion protection, are applied to all body components.

#### **CAUTION:**

**Confine paint removal during welding operation to an absolute minimum.**

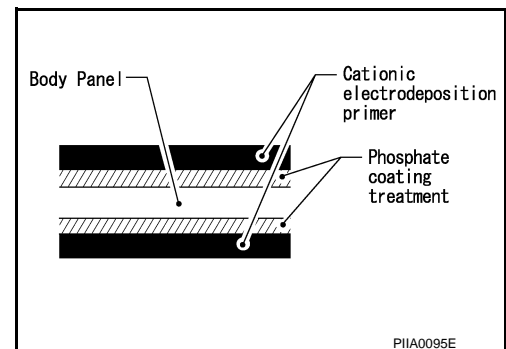

NISSAN genuine parts are also treated in the same manner. Therefore, it is recommended that NISSAN genuine parts or an equivalent be used for panel replacement to maintain anti-corrosive performance built into the vehicle at the factory.

#### Undercoating

INFOID:000000005094291

The underside of the floor and wheelhouse are undercoated to prevent rust, vibration, noise and stone chipping. Therefore, when such a panel is replaced or repaired, apply undercoating to that part. Use an undercoating which is rust resistant, soundproof, vibration-proof, shock-resistant, adhesive, and durable.

#### Precautions in Undercoating

1. Never apply undercoating to any place unless specified (such as the areas above the muffler and three way catalyst that are subjected to heat).
2. Never undercoat the exhaust pipe or other parts that become hot.
3. Never undercoat rotating parts.
4. Apply bitumen wax after applying undercoating.
5. After putting seal on the vehicle, put undercoating on it.

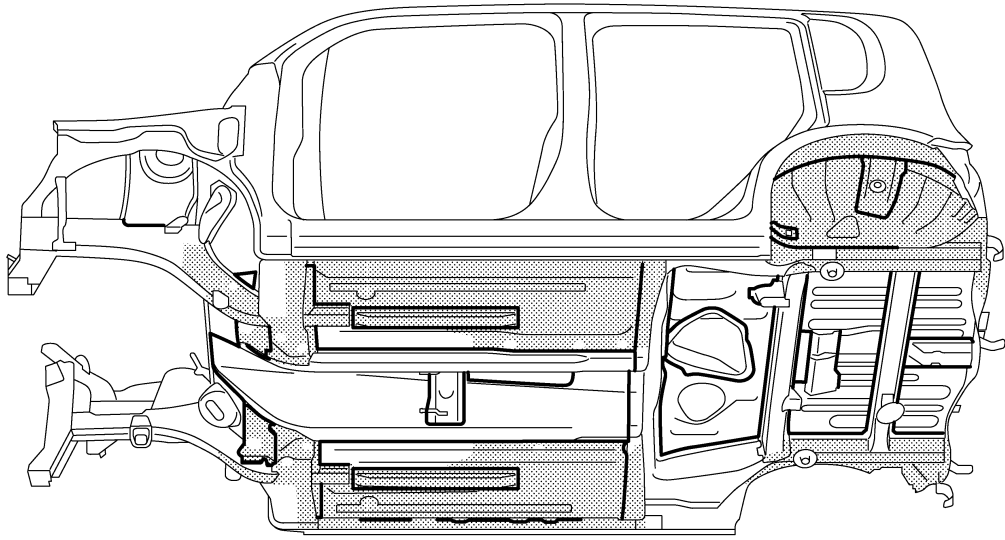

JSKIA1181ZZ

: Undercoated areas

: Sealed portions

## Stone Guard Coat

INFOID:000000005129230

To prevent damage caused by stones, the lower outer body panel (fender, door, etc.) have an additional layer of Stone Guard Coating over the ED primer coating. When replacing or repairing these panels, apply Stone Guard coating to the same portions as before. Use a coating which is rust preventive, durable, shock-resistant and has a long shelf life.

BRM

# CORROSION PROTECTION

< REMOVAL AND INSTALLATION >

[REGULAR GRADE]

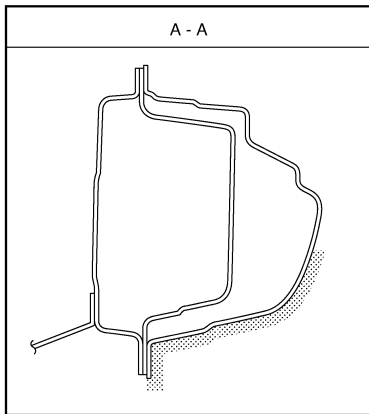
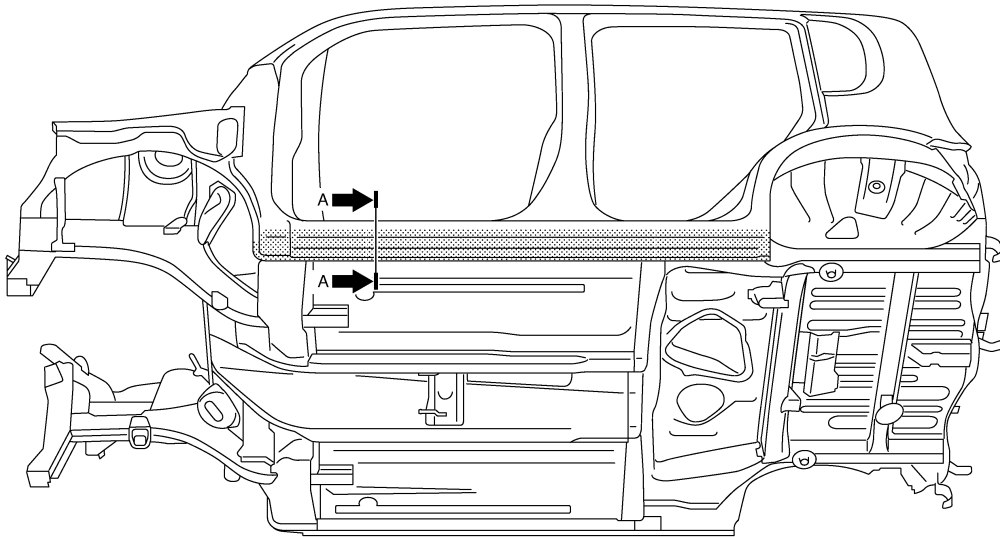

JSKIA1182ZZ

 : Stone guard coated portions

## Body Sealing

INFOID:000000005094292

The following figure shows the areas that are sealed at the factory. Sealant that is applied to these areas should be smooth and free from cuts or gaps. Care should be taken not to apply an excess amount of sealant and not to allow other unaffected parts to come into contact with the sealant.

# CORROSION PROTECTION

< REMOVAL AND INSTALLATION >

[REGULAR GRADE]

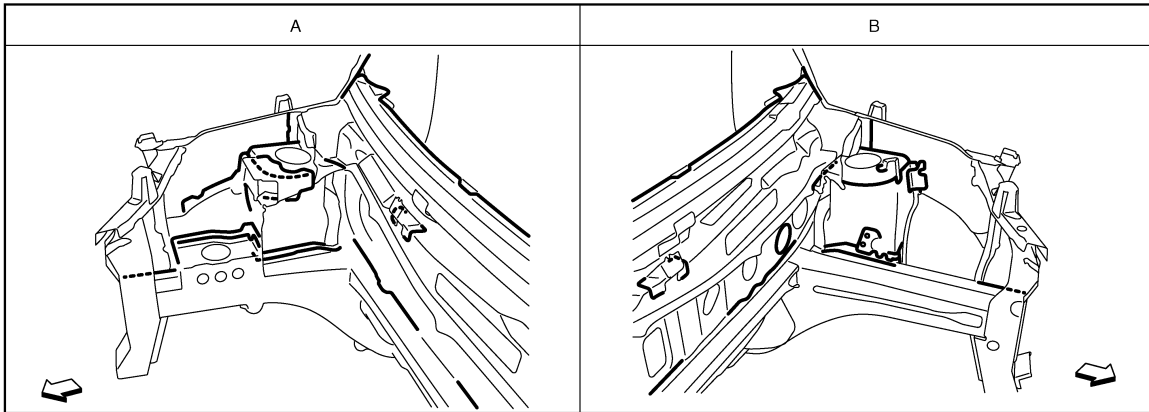
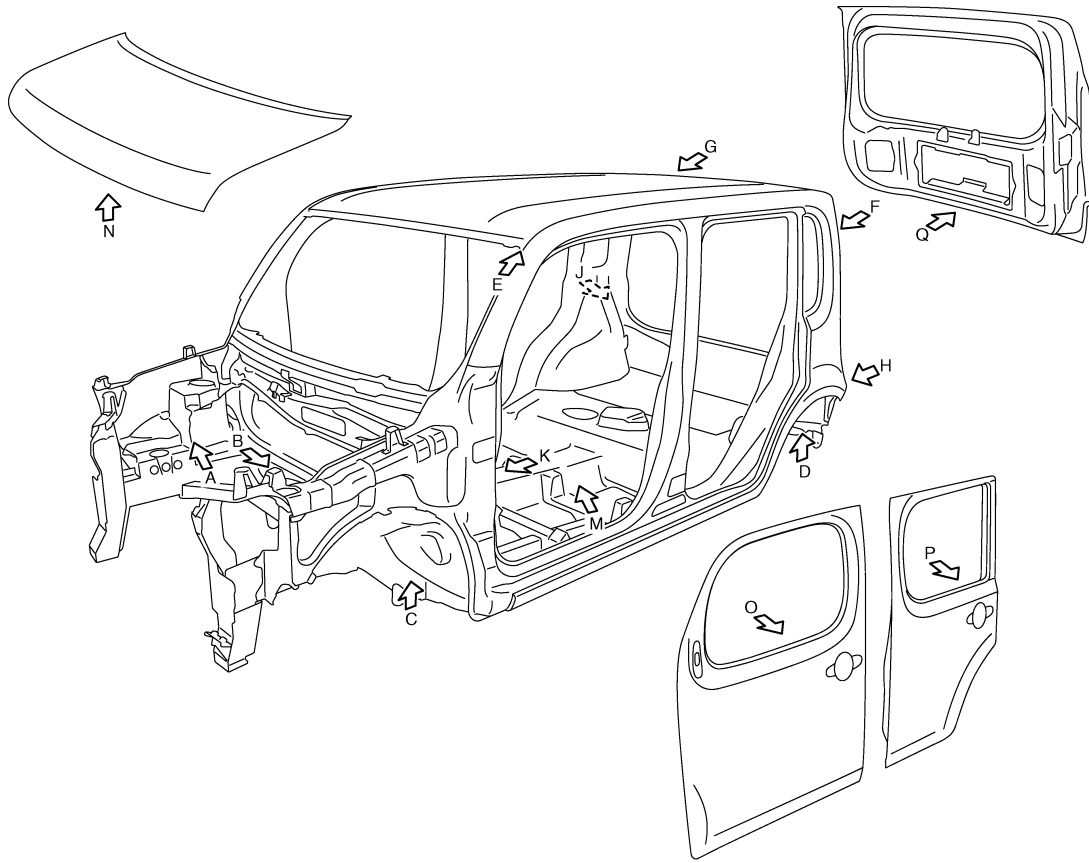

JSKIA1183ZZ

←: Vehicle front

—: Sealed portions

A  
B  
C  
D  
E  
F  
G  
H  
I  
J  
K  
L  
M  
N  
O  
P

BRM

# CORROSION PROTECTION

< REMOVAL AND INSTALLATION >

[REGULAR GRADE]

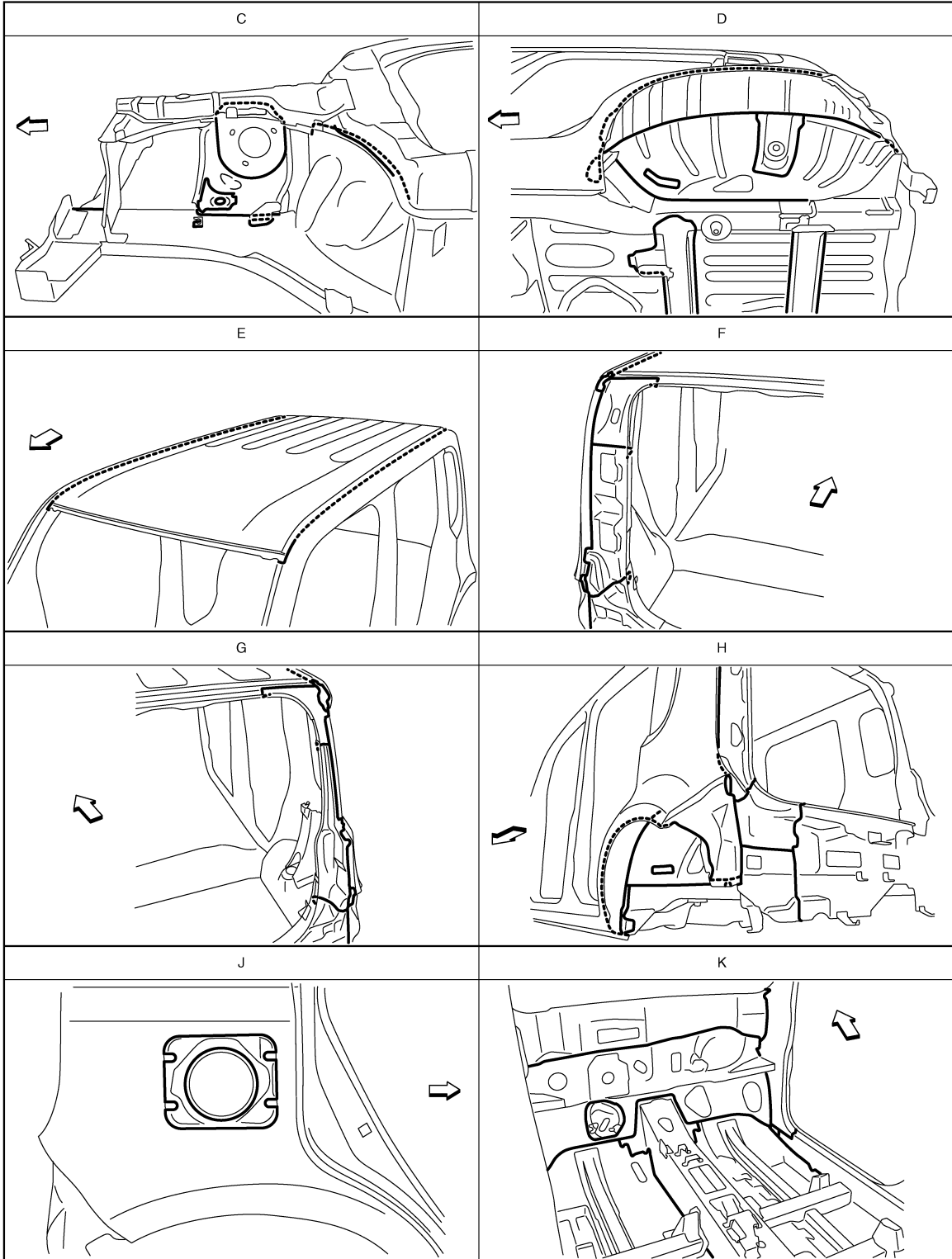

JSKIA1184ZZ

↔: Vehicle front

—: Sealed portions



# CORROSION PROTECTION

< REMOVAL AND INSTALLATION >

[REGULAR GRADE]

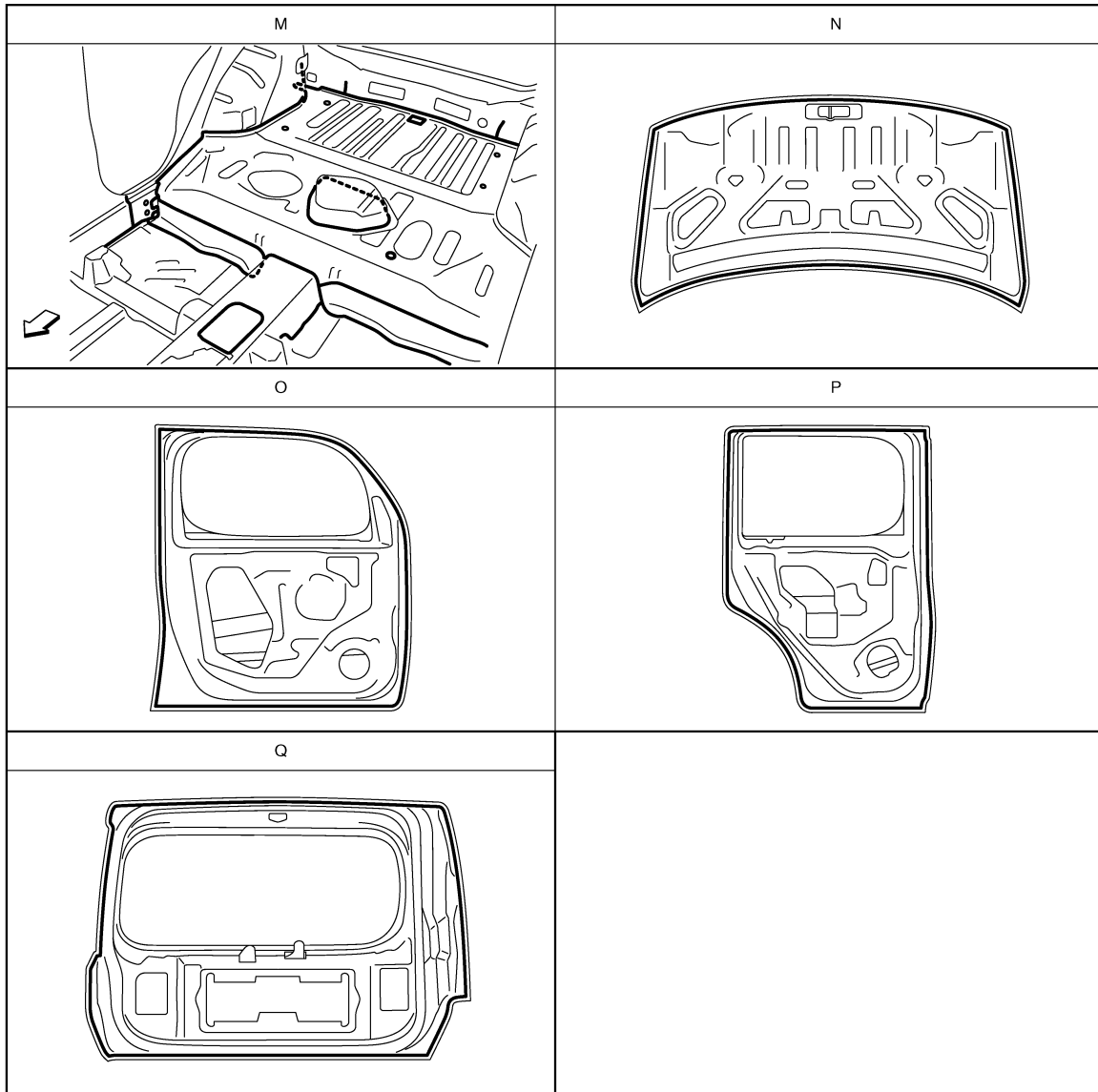

A  
B  
C  
D  
E  
F  
G  
H  
I  
J  
L  
M  
N  
O  
P

BRM

JSKIA1185ZZ

←: Vehicle front  
—: Sealed portions

# BODY CONSTRUCTION

< REMOVAL AND INSTALLATION >

[REGULAR GRADE]

## BODY CONSTRUCTION

### Body Construction

INFOID:000000005094293

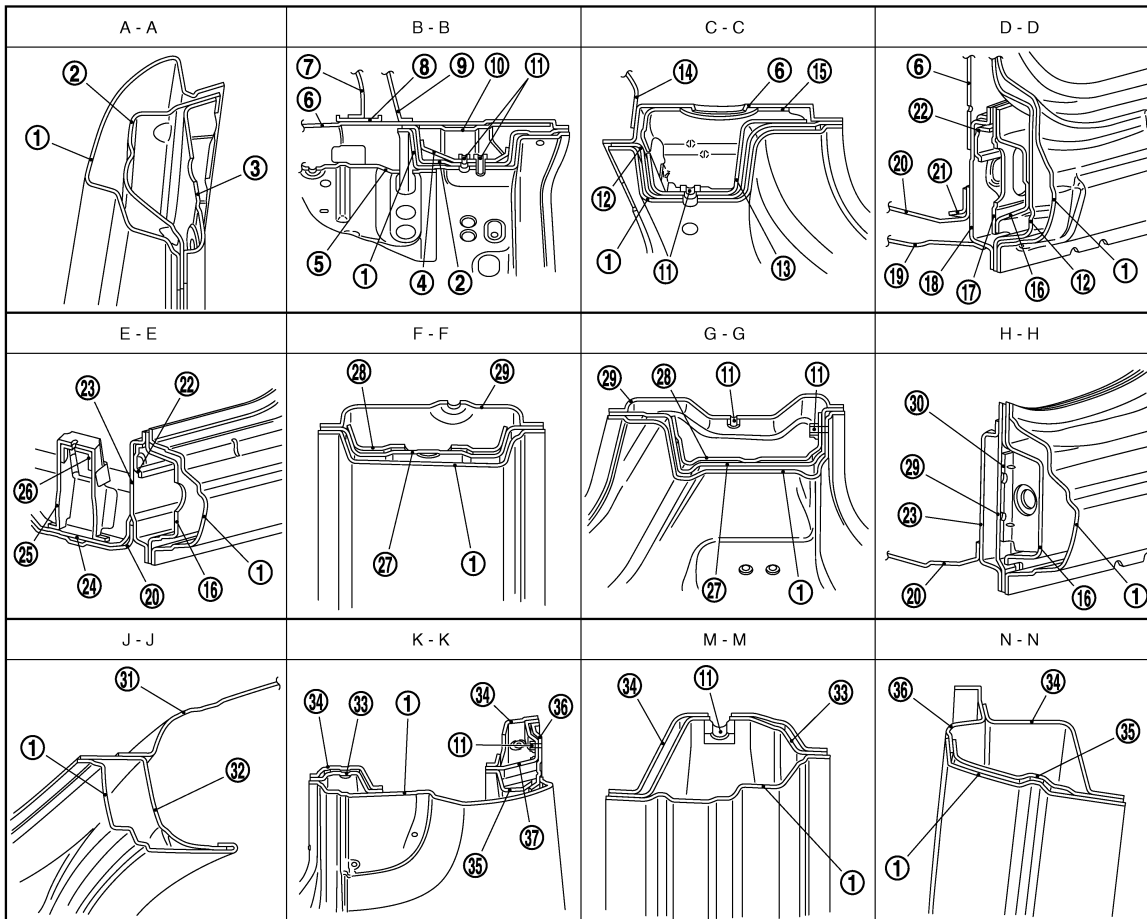
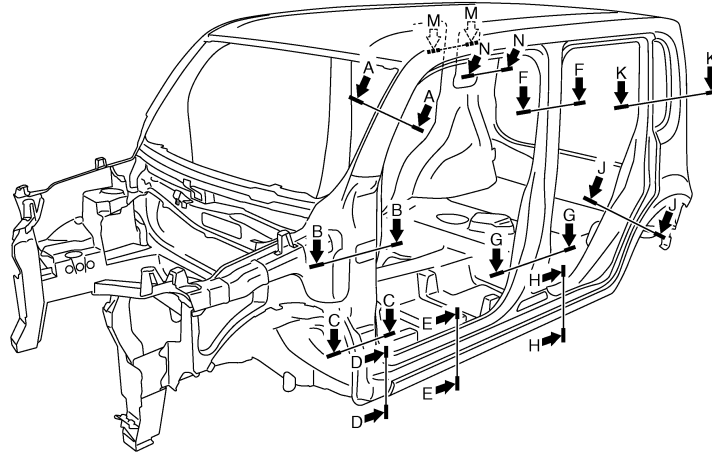

- 1. Outer side body
- 4. Upper hinge plate
- 7. Cowl top

- 2. Outer front pillar reinforcement
- 5. Hoodledge reinforcement
- 8. Cowl top stay

- 3. Upper inner front pillar
- 6. Side dash
- 9. Upper dash

JSKIA1186ZZ

# BODY CONSTRUCTION

## < REMOVAL AND INSTALLATION >

[REGULAR GRADE]

- |                                      |  |                                      |
|--------------------------------------|--|--------------------------------------|
| 10. Inner front pillar reinforcement | 11. Weld nut                                   | 12. Lower front pillar hinge brace   |
| 13. Lower hinge plate                | 14. Lower dash                                 | 15. Inner front pillar reinforcement |
| 16. Outer sill reinforcement         | 17. Lower front pillar reinforcement           | 18. Inner sill                       |
| 19. Front outrigger                  | 20. Front floor                                | 21. Front floor reinforcement        |
| 22. Inner sill reinforcement         | 23. Inner sill                                 | 24. 2nd crossmember                  |
| 25. Outer front seat mount bracket   | 26. Outer front seat mount front reinforcement | 27. Center pillar reinforcement      |
| 28. Lower lock pillar reinforcement  | 29. Inner center pillar                        | 30. Outer sill brace                 |
| 31. Inner rear wheelhouse            | 32. Outer rear wheelhouse                      | 33. Rear pillar seat belt anchor     |
| 34. Inner rear pillar                | 35. Back pillar reinforcement                  | 36. Lower outer back pillar          |
| 37. Upper hinge brace                |  |                                      |

## Rear Fender Hemming Process

INFOID:000000005094294

1. A wheel arch is to be installed and hemmed over the left and right outer wheel houses.
2. In order to hem the wheel arch, it is necessary to repair any damaged or defaced parts around outer wheel house.

### CAUTION:

**Ensure that the area that is to be glued around the outer wheelhouse is undamaged or defaced.**

### PROCEDURE OF THE HEMMING PROCESS

- Peel off old bonding material on the surface of the outer wheelhouse and clean thoroughly.
- Peel off a primer coat in the specified area where new adhesive is to be applied on rear fender (the replacing part).
- Apply new adhesive to both specified areas of the outer wheelhouse and rear fender.

**<Adhesive> 3M™ Automix™ Panel Bonding Adhesive 08115 or equivalent**

- Attach rear fender to the body of the car, and weld the required part except the hemming part.

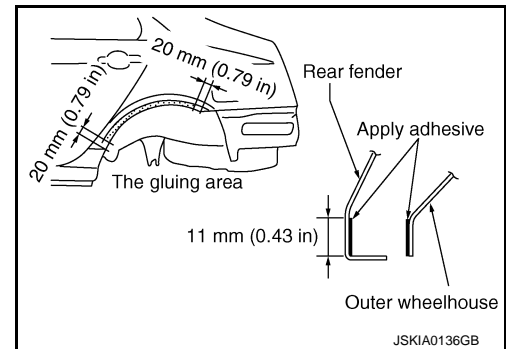

- Bend the welded part starting from the center of the wheel arch gradually with a hammer and a dolly. (Also hem the end of the flange.)
- Hemming with a hammer is conducted to an approximate angle of 80 degrees.

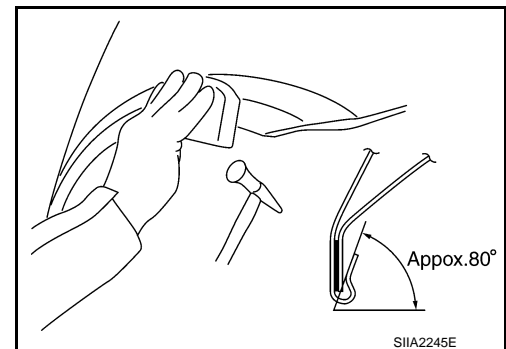

- Starting from the center, hem the wheel arch gradually, using slight back and forth motion with a hemming tool.

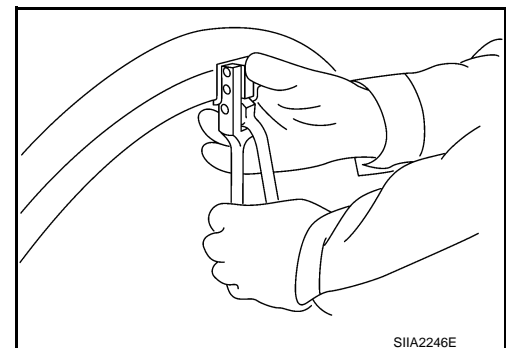

A  
B  
C  
D  
E  
F  
G  
H  
I  
J  
BRM  
L  
M  
N  
O  
P

## BODY CONSTRUCTION

< REMOVAL AND INSTALLATION >

[REGULAR GRADE]

- Seal up the area around the hemmed end of the flange.

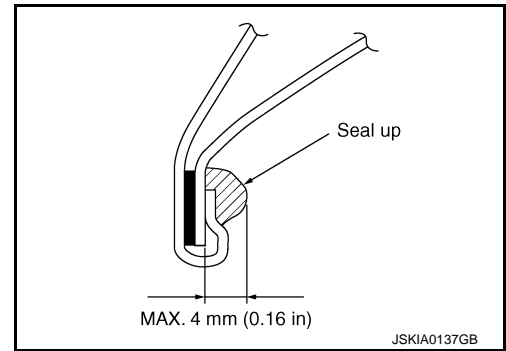

# REPLACEMENT OPERATIONS

< REMOVAL AND INSTALLATION >

[REGULAR GRADE]





## REPLACEMENT OPERATIONS

### Description

INFOID:000000005094295

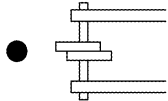
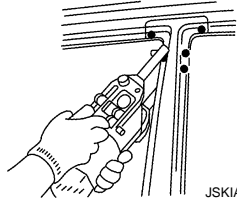
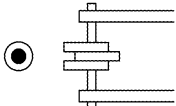
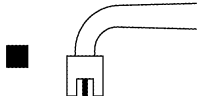
- This section is prepared for technicians who have attained a high level of skill and experience in repairing collision-damaged vehicles and also use modern service tools and equipment. Persons unfamiliar with body repair techniques should not attempt to repair collision-damaged vehicles by using this section.
- Technicians are also encouraged to read the Body Repair Manual (Fundamentals) in order to ensure that the original functions and quality of the vehicle are maintained. The Body Repair Manual (Fundamentals) contains additional information, including cautions and warnings, that are not including in this manual. Technicians should refer to both manuals to ensure proper repair.
- Please note that this information is prepared for worldwide usage, and as such, certain procedures might not apply in some regions or countries.

The symbols used in this section for welding operations are shown below.

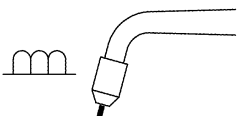
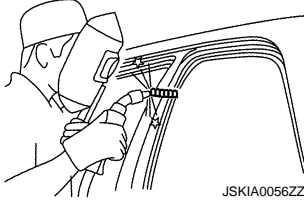
Symbol marks	Description	
 <p>JSKIA0049ZZ</p>	2-spot welds	 <p>JSKIA0053ZZ</p>
 <p>JSKIA0050ZZ</p>	3-spot welds	
 <p>JSKIA0051ZZ</p>	MIG plug weld	 <p>JSKIA0054ZZ</p> <p>For 3 panels plug weld method</p> <div style="display: flex; flex-direction: column; align-items: center;"> <div data-bbox="1144 1438 1307 1480"> <p>■ A </p> </div> <div data-bbox="1144 1533 1307 1575"> <p>■ B </p> </div> </div> <p>JSKIA0055ZZ</p>
 <p>JSKIA0052ZZ</p>	MIG seam weld / Point weld	 <p>JSKIA0056ZZ</p>

A  
B  
C  
D  
E  
F  
G  
H  
I  
J  
L  
M  
N  
O  
P

BRM

# REPLACEMENT OPERATIONS

## < REMOVAL AND INSTALLATION >

[REGULAR GRADE]

- Front pillar butt joint can be determined anywhere within shaded area as shown in the figure. The best location for the butt joint is at position A due to the construction of the vehicle.

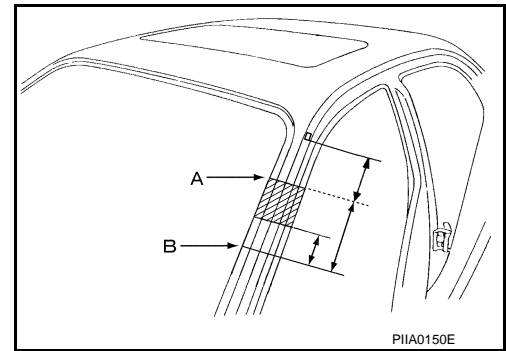

- Determine cutting position and record distance from the locating indent. Use this distance when cutting the service part. Cut outer front pillar over 60 mm (2.36 in) above the inner front pillar cut position.

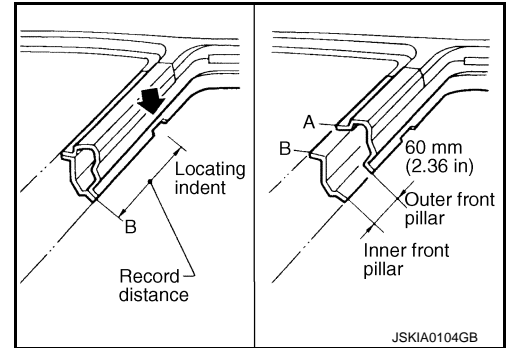

- Prepare a cutting jig to make outer pillar easier to cut. Also, this will permit the service part to be accurately cut at the joint position.

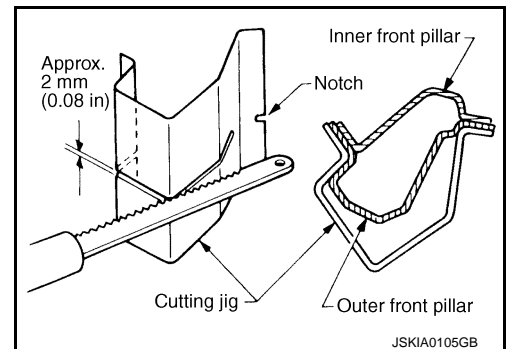

- An example of cutting operation using a cutting jig is as per the following.

1. Mark cutting lines.  
A: Cut position of outer pillar  
B: Cut position of inner pillar
2. Align cutting line with notch on jig. Clamp jig to pillar.
3. Cut outer pillar along groove of jig (at position A).
4. Remove jig and cut remaining portions.
5. Cut inner pillar at position B in same manner.

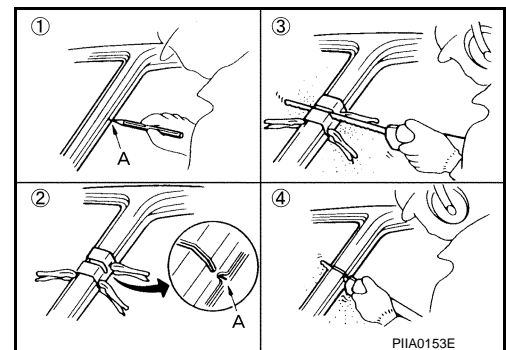

# REPLACEMENT OPERATIONS

< REMOVAL AND INSTALLATION >

[REGULAR GRADE]

## Radiator Core Support

INFOID:000000005094296

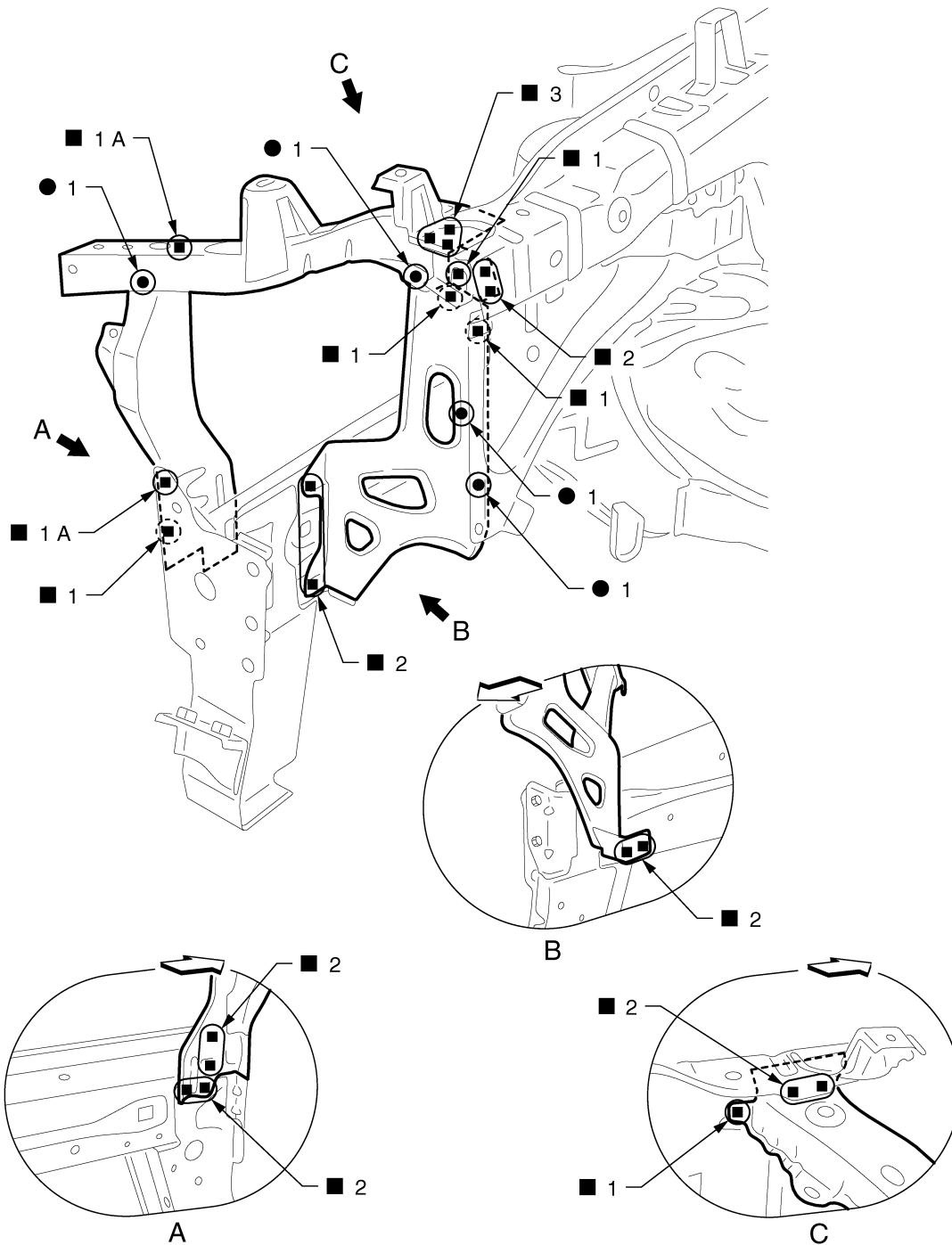

A  
B  
C  
D  
E  
F  
G  
H  
I  
J  
K  
L  
M  
N  
O  
P

BRM

← Vehicle front

( ): Weld the parts onto the back of the component part.

Replacement parts

- Side radiator core support (LH)
- Side radiator core reinforcement (LH)
- Hoodledge connector (LH)

## Hoodledge

INFOID:000000005094297

Work after radiator core support is removed.

# REPLACEMENT OPERATIONS

< REMOVAL AND INSTALLATION >

[REGULAR GRADE]

Remove the front side closing plate reinforcement (reusable) and front side rear closing reinforcement (reusable).

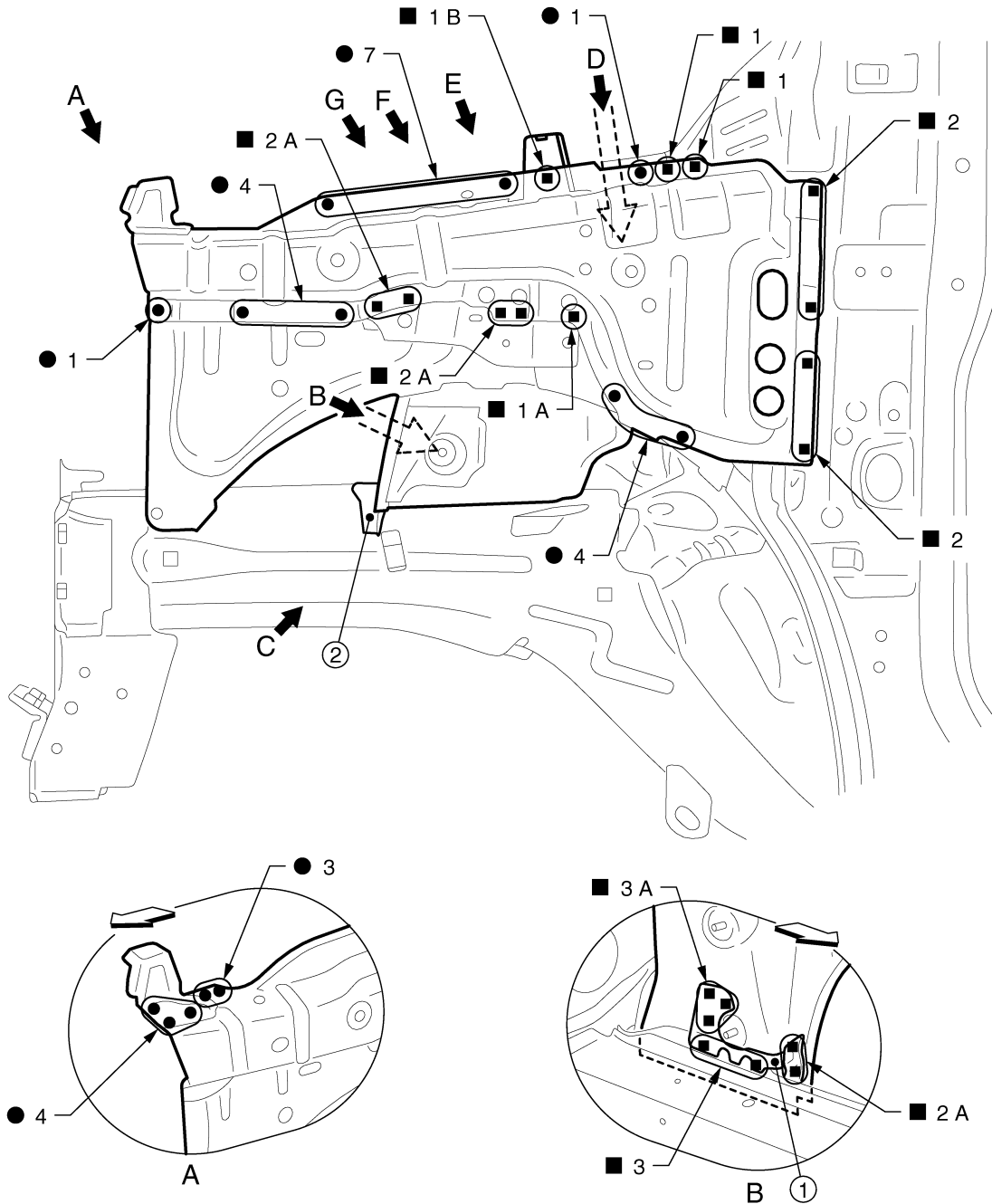

JSKIA1151ZZ

- 1. Front side closing plate reinforcement
- 2. Front side rear closing reinforcement

←: Vehicle front

Replacement parts

- Upper hoodledge (LH)
- Hoodledge reinforcement (LH)
- Front strut housing (LH)
- Hoodledge reinforcement gusset



# REPLACEMENT OPERATIONS

< REMOVAL AND INSTALLATION >

[REGULAR GRADE]

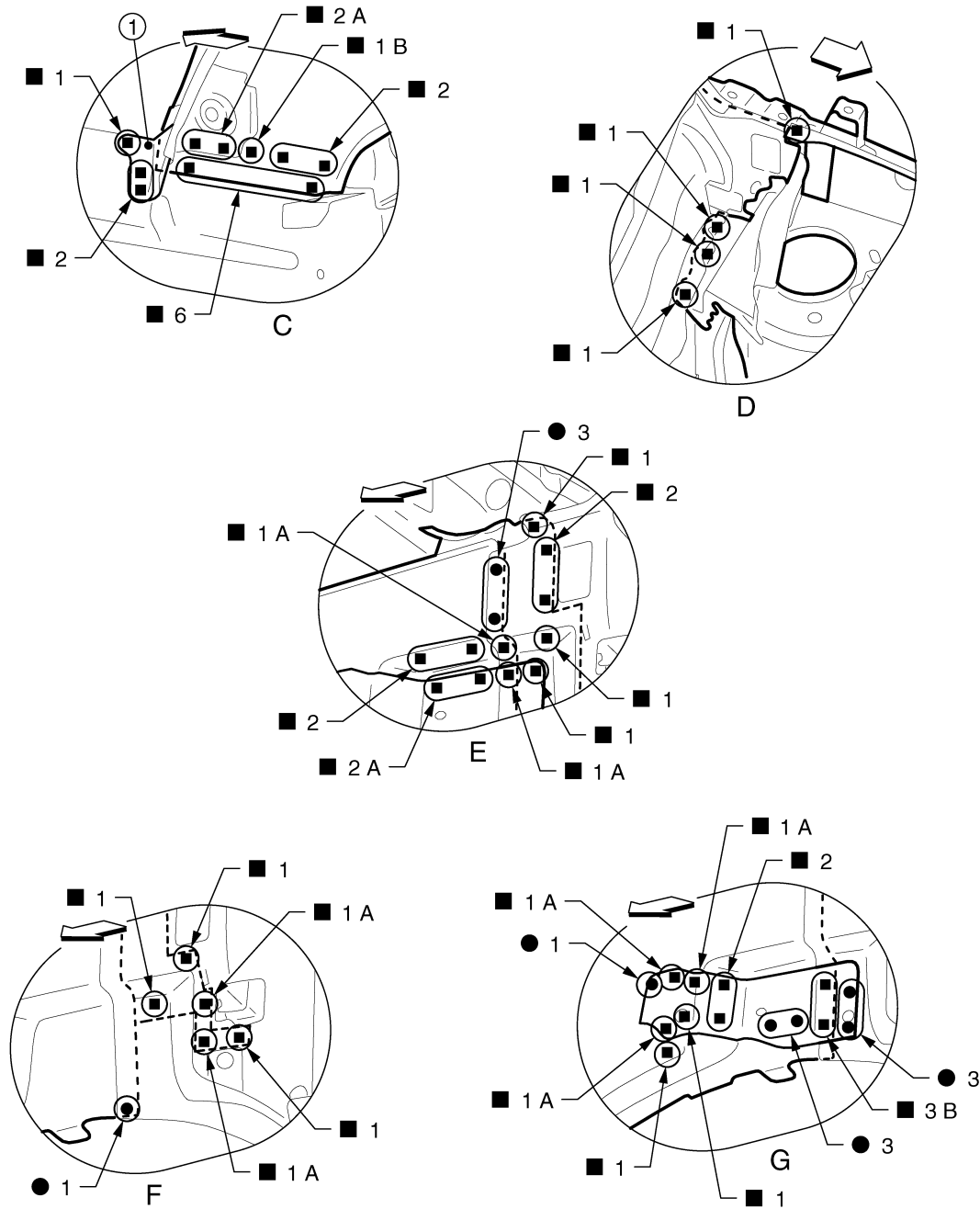

- 1. Front side rear closing reinforcement
- ↔: Vehicle front

View E and G: Before installing hoodledge reinforcement  
 View F: Before installing hoodledge reinforcement and hoodledge reinforcement gusset

## Hoodledge (Partial Replacement)

Work after radiator core support is removed.

JSKIA1152ZZ

INFOID:000000005128474

A  
B  
C  
D  
E  
F  
G  
H  
I  
J  
K  
L  
M  
N  
O  
P

BRM

# REPLACEMENT OPERATIONS

< REMOVAL AND INSTALLATION >

[REGULAR GRADE]

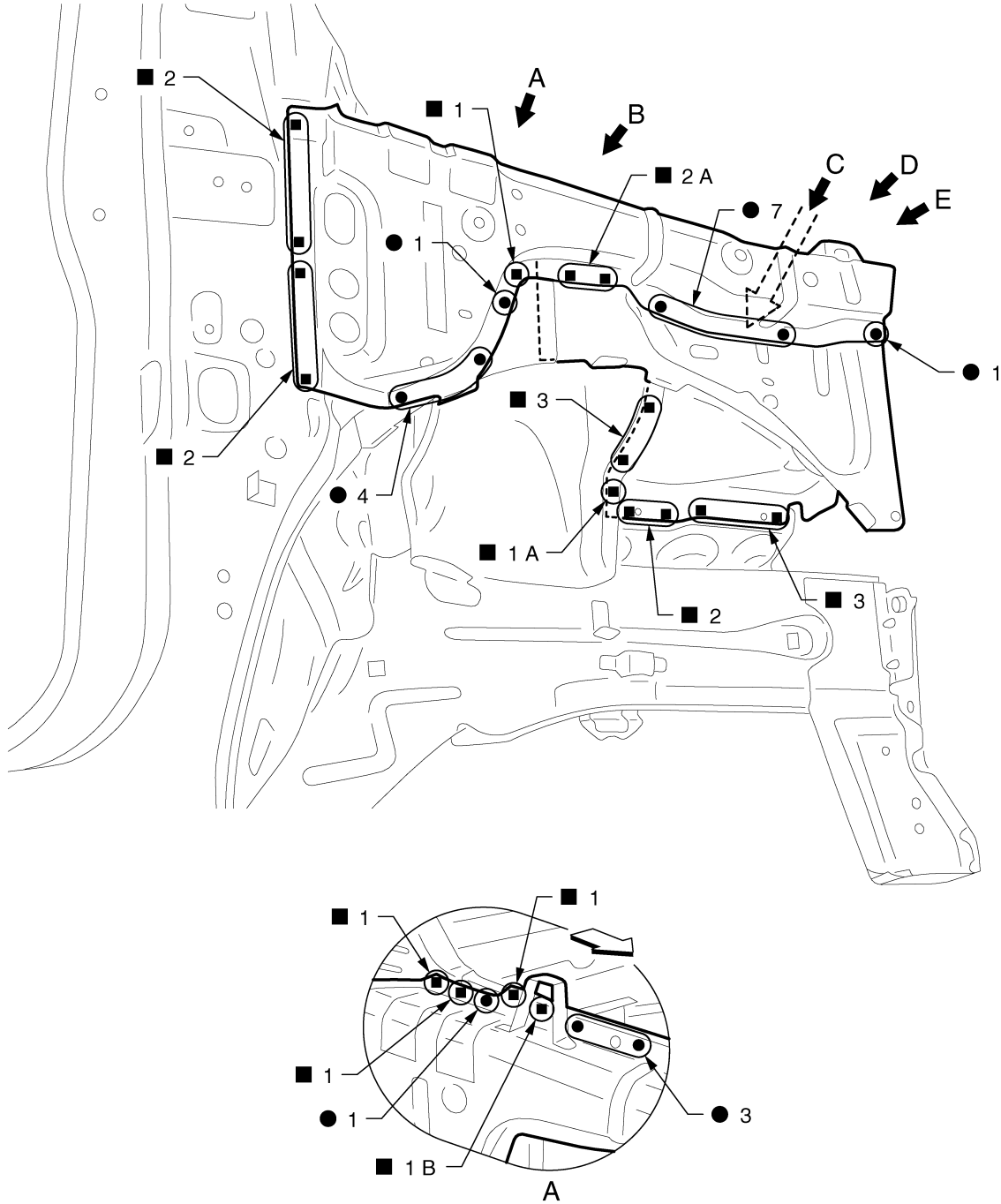

JSKIA1153ZZ

←: Vehicle front

Replacement parts

● Upper hoodledge (RH)

● Hoodledge reinforcement (RH)

● Lower front hoodledge

# REPLACEMENT OPERATIONS

< REMOVAL AND INSTALLATION >

[REGULAR GRADE]

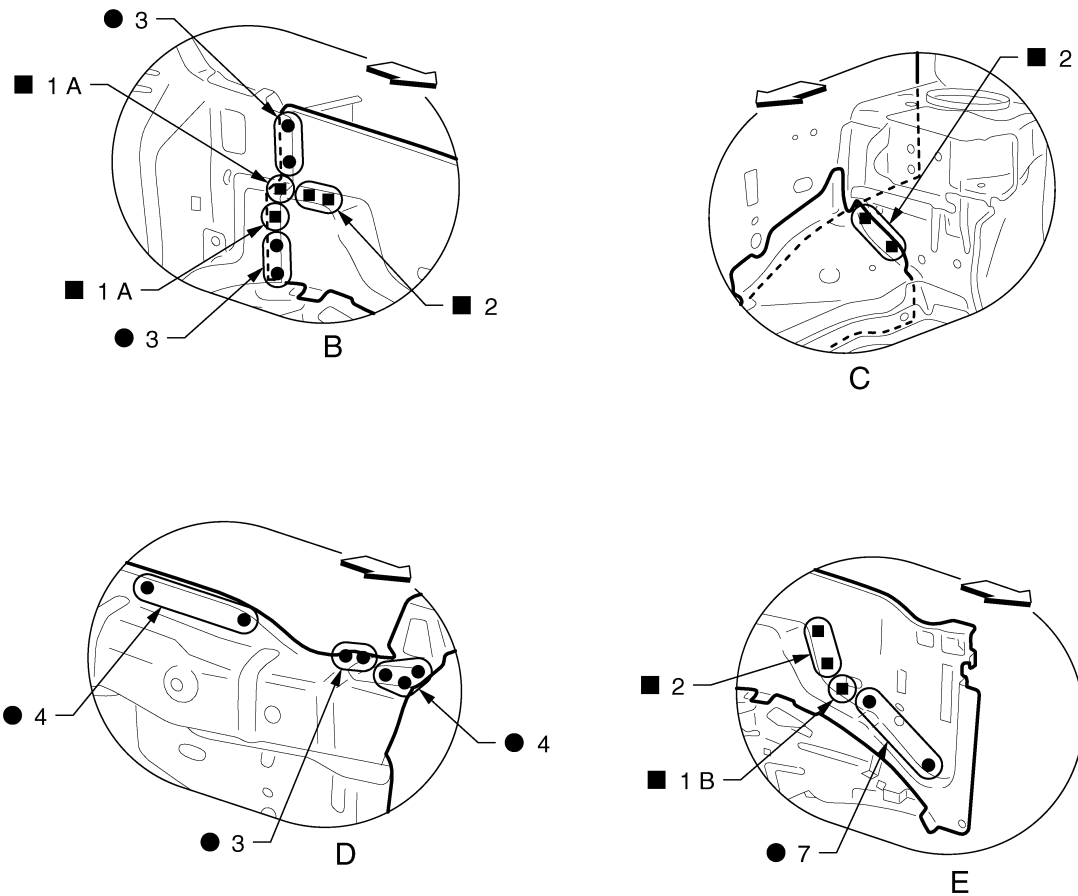

A  
B  
C  
D  
E  
F  
G  
H  
I  
J

BRM

L  
M  
N  
O  
P

JSKIA1154ZZ

←: Vehicle front

View B and E: Before installing hoodledge reinforcement

## Front Side Member

INFOID:000000005094298

Work after radiator core support and hoodledge are removed.  
Remove the front side closing plate reinforcement (reusable) and front side rear closing reinforcement (reusable) from the service part "front side member closing plate assembly" for easier installation of hoodledge.

# REPLACEMENT OPERATIONS

< REMOVAL AND INSTALLATION >

[REGULAR GRADE]

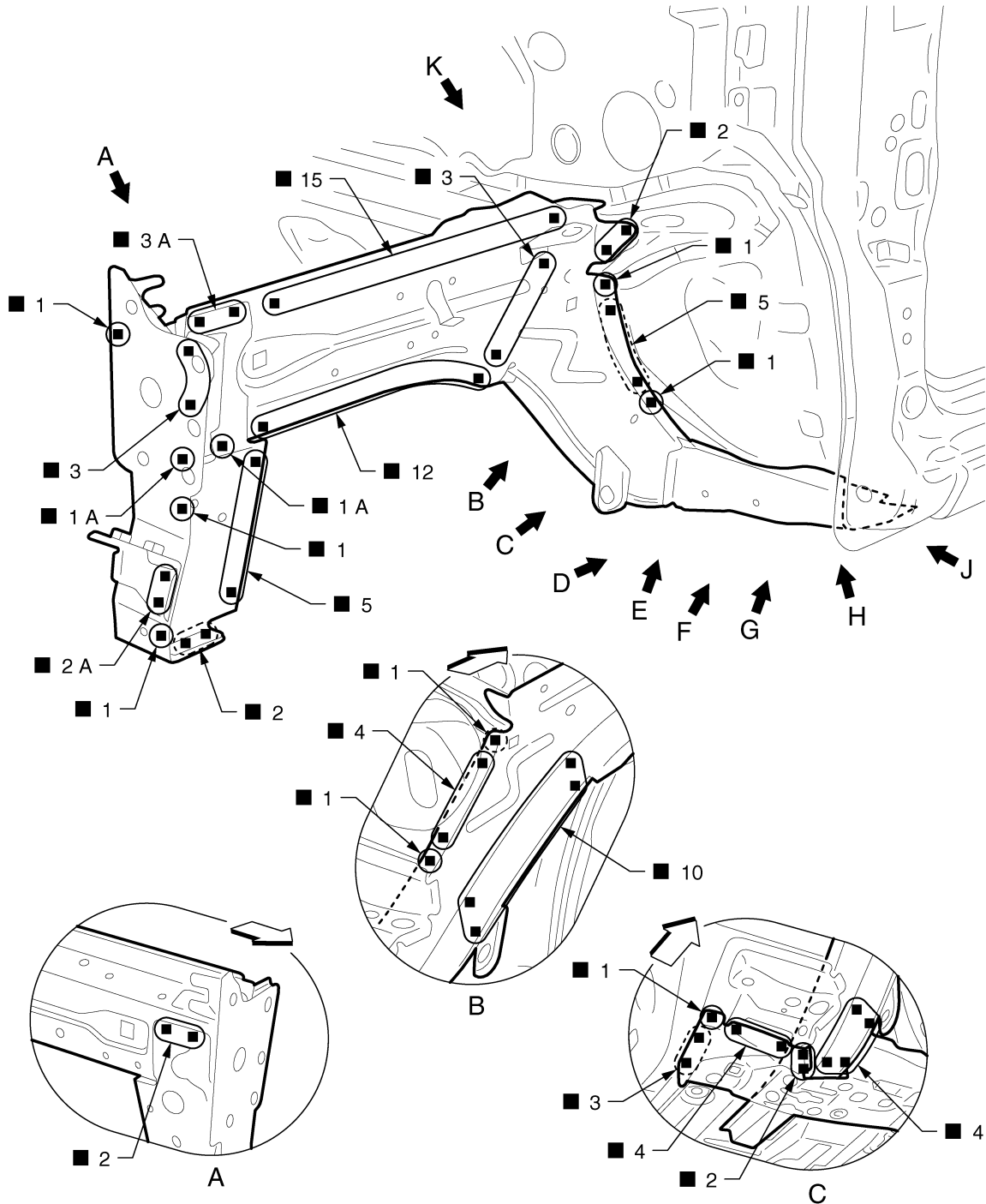

JSKIA1155ZZ

← Vehicle front

○ Weld the parts onto the back of the component part.

Replacement parts

- Front side member assembly (LH)
- Front side member closing plate assembly (LH)
- Front suspension mounting bracket (LH)

# REPLACEMENT OPERATIONS

< REMOVAL AND INSTALLATION >

[REGULAR GRADE]

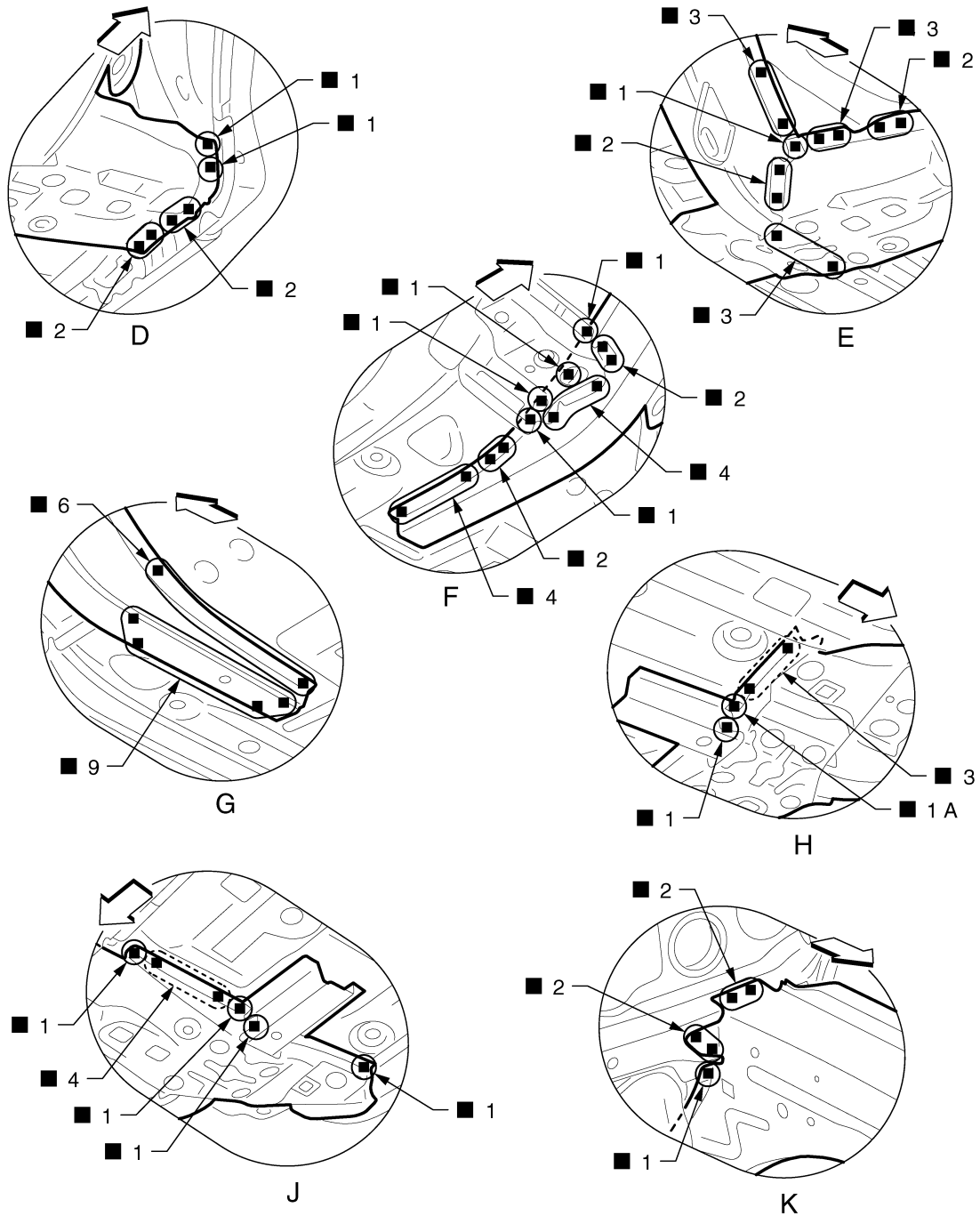

← Vehicle front

○: Weld the parts onto the back of the component part.

View F and G: Before installing front suspension mounting bracket  
**Front Side Member (Partial Replacement)**

Work after radiator core support is removed.

JSKIA1156ZZ

INFOID:000000005094299

A  
B  
C  
D  
E  
F  
G  
H  
I  
J  
K  
L  
M  
N  
O  
P

**BRM**

# REPLACEMENT OPERATIONS

< REMOVAL AND INSTALLATION >

[REGULAR GRADE]

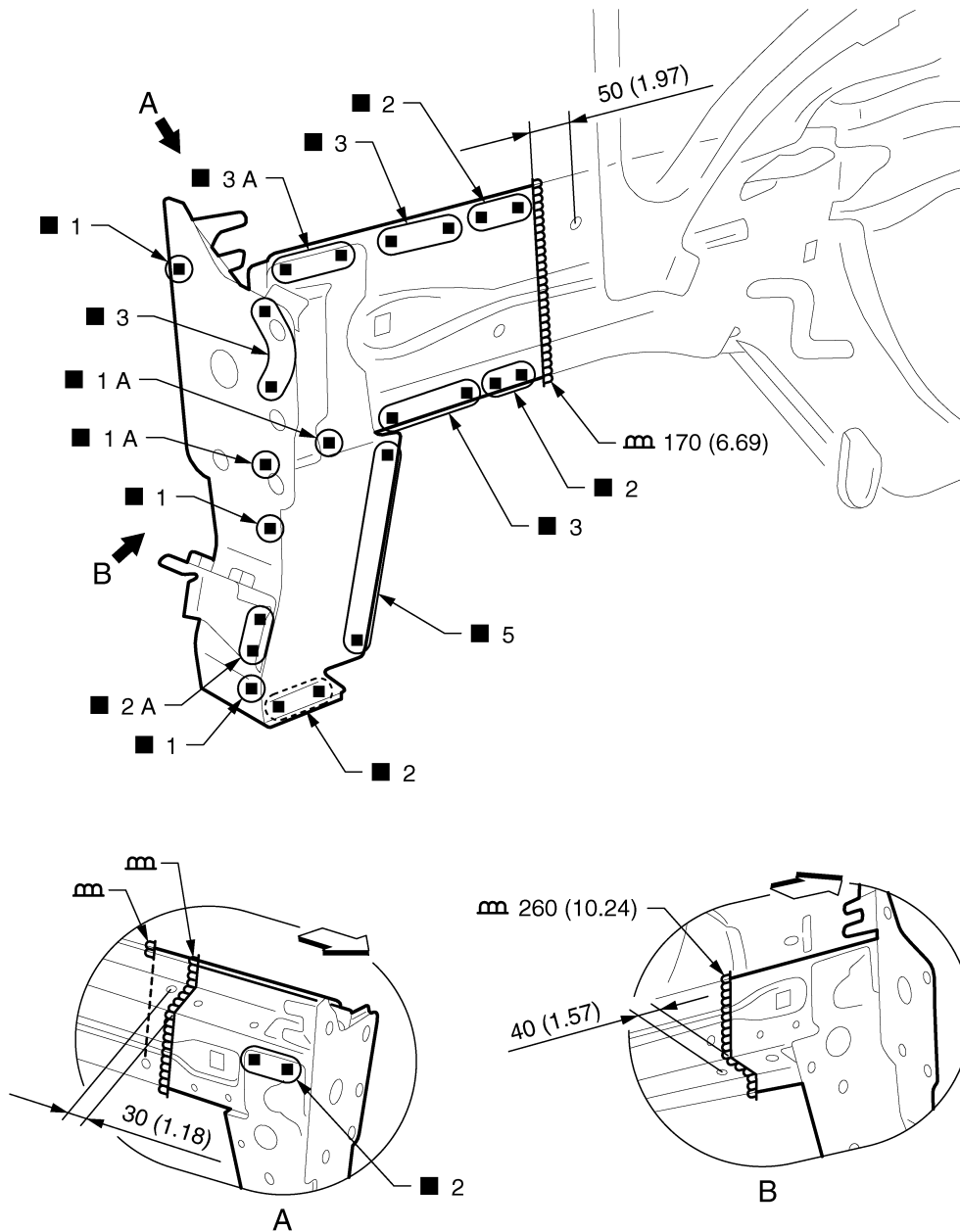

JSKIA1157GB

Unit: mm (in)

↔: Vehicle front

○: Weld the parts onto the back of the component part.

Replacement parts

- Front side member assembly (LH)
- Front side member closing plate assembly (LH)

## Front Pillar

INFOID:000000005094301

Work after hoodledge reinforcement is removed.

# REPLACEMENT OPERATIONS

< REMOVAL AND INSTALLATION >

[REGULAR GRADE]

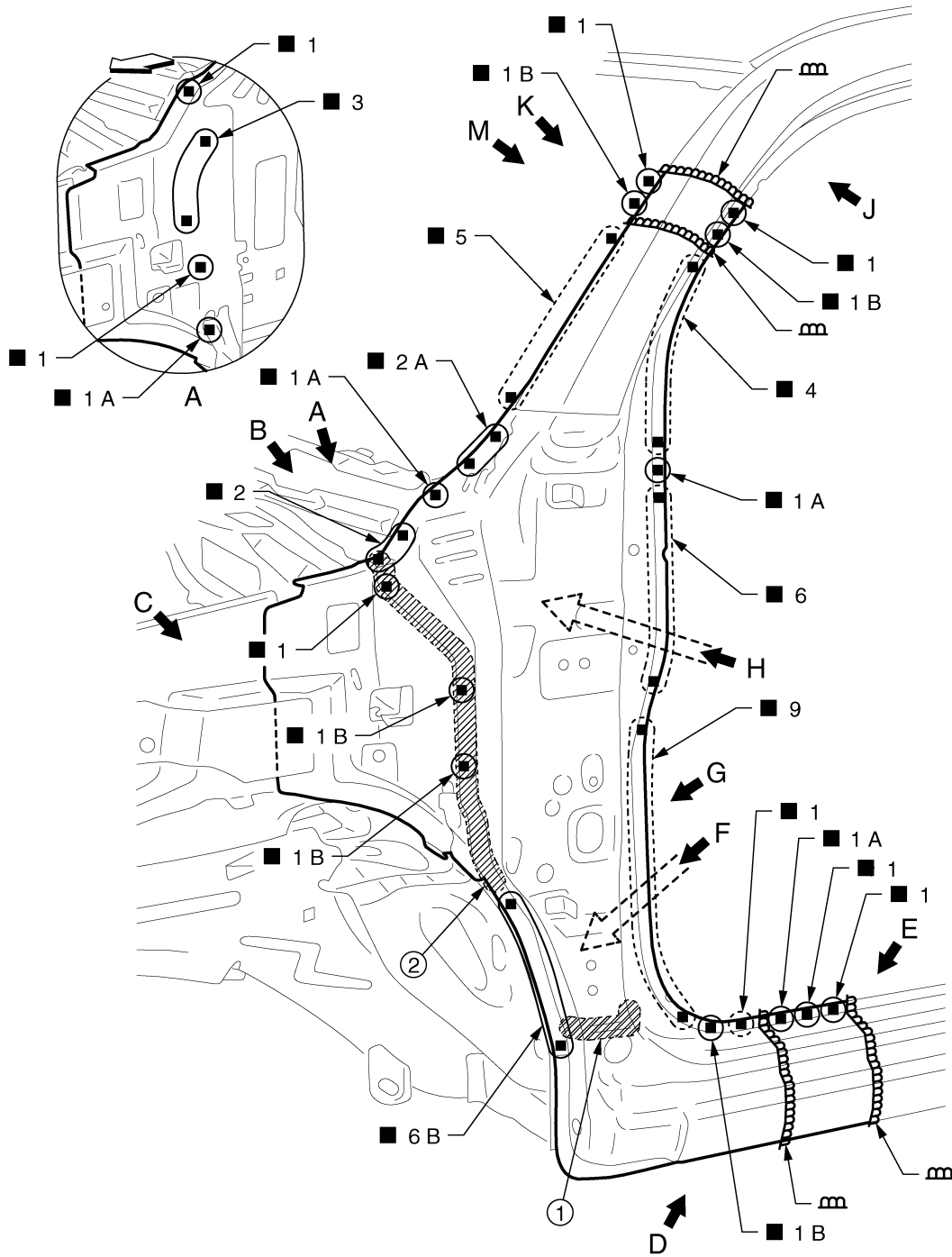

JSKIA1158ZZ

1. Urethane foam

2. Body sealing

⇐: Vehicle front

⊙: Weld the parts onto the back of the component part.

Replacement parts

● Side body assembly (LH)

● Side dash (LH)

● Upper inner front pillar (LH)

View A: Before installing side body assembly

A  
B  
C  
D  
E  
F  
G  
H  
I  
J  
K  
L  
M  
N  
O  
P

BRM

# REPLACEMENT OPERATIONS

< REMOVAL AND INSTALLATION >

[REGULAR GRADE]

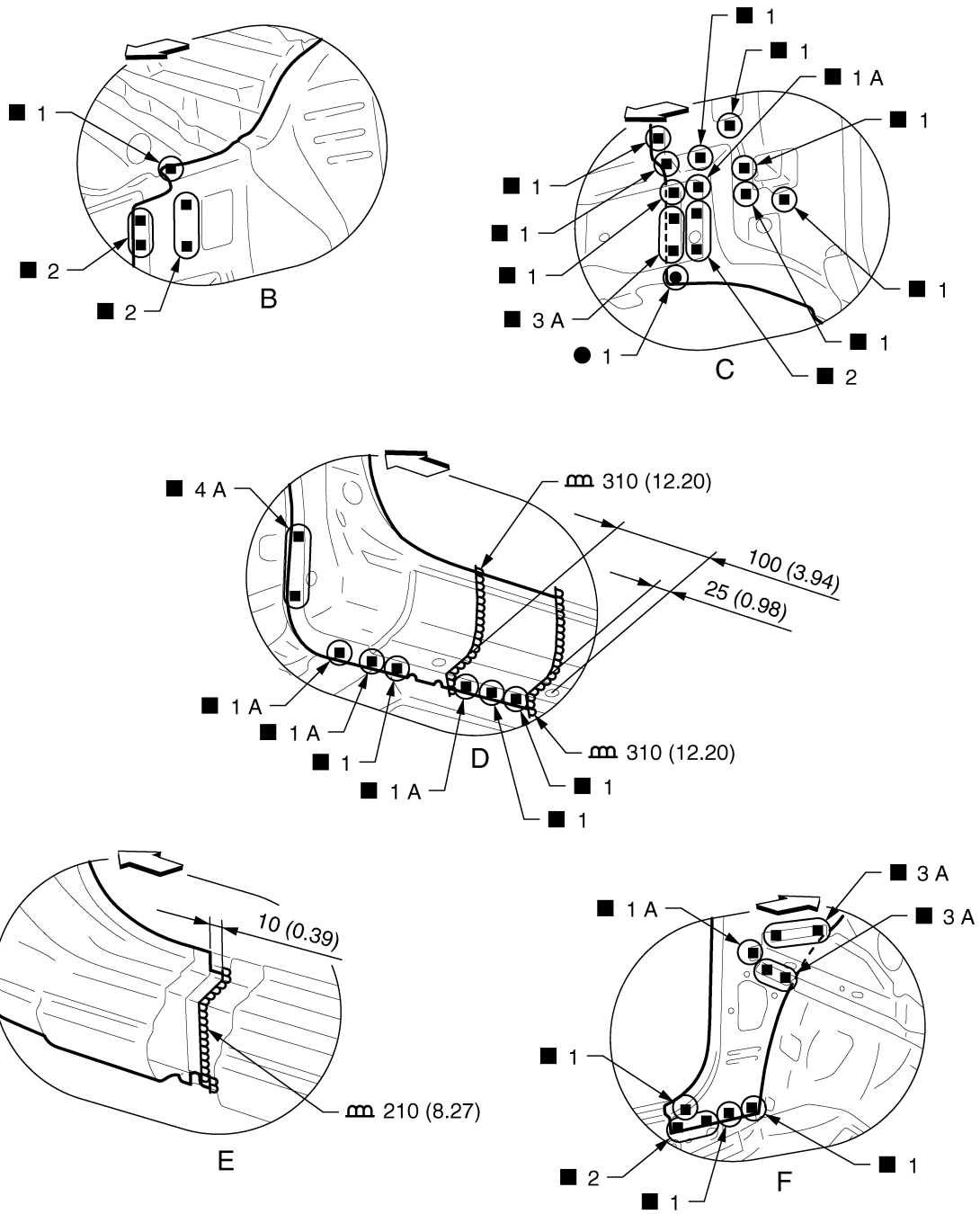

JSKIA1159GB

Unit: mm (in)

↔: Vehicle front

View E: Before installing outer front side body



# REPLACEMENT OPERATIONS

< REMOVAL AND INSTALLATION >

[REGULAR GRADE]

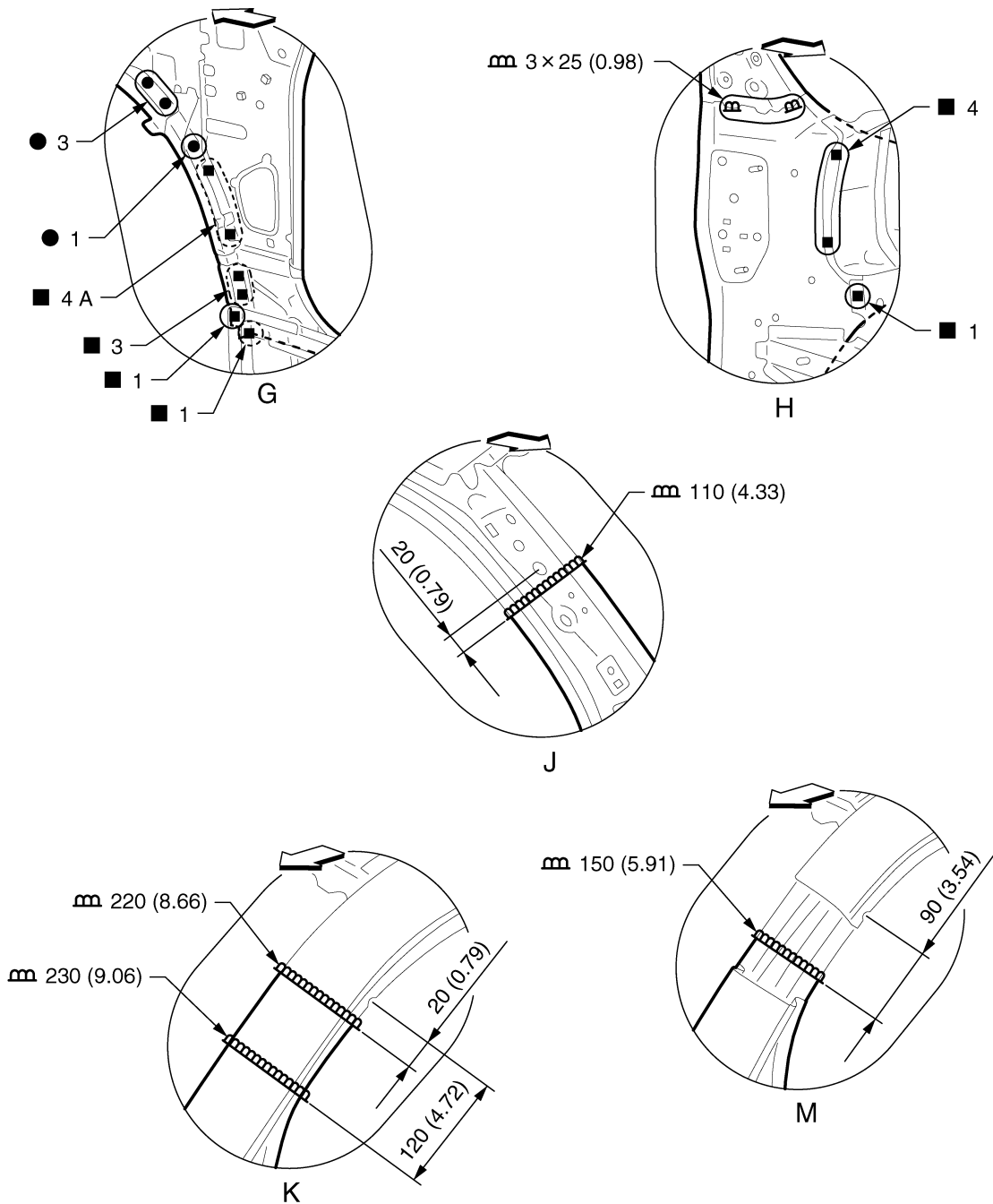

Unit: mm (in)

↔: Vehicle front

○: Weld the parts onto the back of the component part.

View G: Before installing side body assembly

View M: Before installing outer front side body

## Center Pillar

INFOID:000000005128475

Never cut and joint the lower lock pillar reinforcement, because it is made of ultra high strength steel plate. Remove the reusable area of the outer front side body (see View J and K) from the vehicle for easier installation.

A  
B  
C  
D  
E  
F  
G  
H  
I  
J  
K  
L  
M  
N  
O  
P

BRM

# REPLACEMENT OPERATIONS

< REMOVAL AND INSTALLATION >

[REGULAR GRADE]

Install the inner center pillar to the side body assembly as shown in the figure for repairing the hidden welding point "View M".

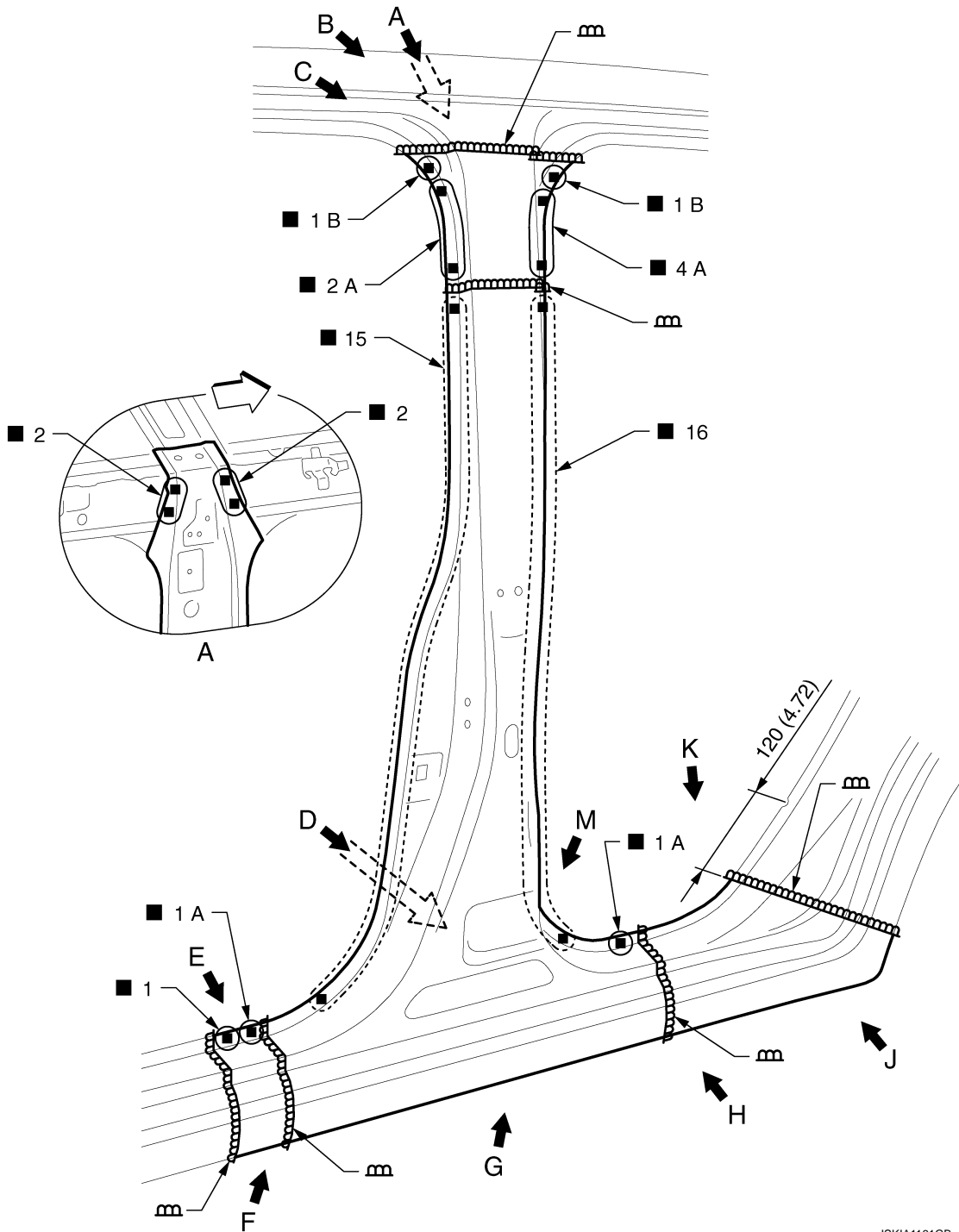

JSKIA1161GB

Unit: mm (in)

↔ Vehicle front

(○): Weld the parts onto the back of the component part.

Replacement parts

- Side body assembly (LH)
- Inner center pillar (LH)

# REPLACEMENT OPERATIONS

< REMOVAL AND INSTALLATION >

[REGULAR GRADE]

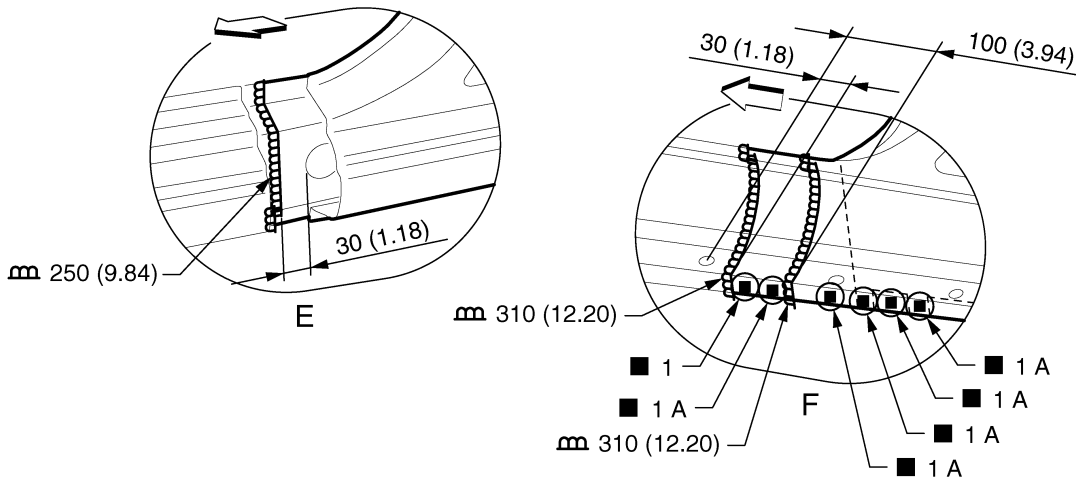
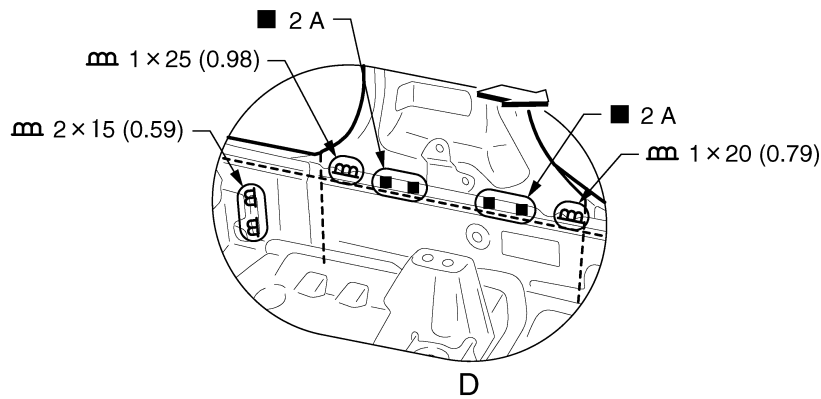
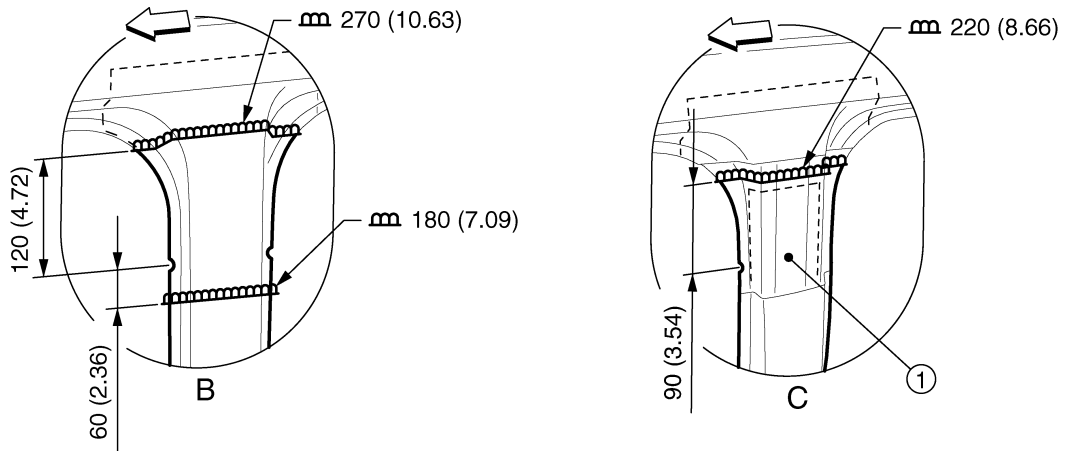

JSKIA1162GB

1. Lower lock pillar reinforcement (ultra high strength steel plate)

Unit: mm (in)

↔: Vehicle front

View C and E: Before installing outer front side body

A  
B  
C  
D  
E  
F  
G  
H  
I  
J  
K  
L  
M  
N  
O  
P

BRM

# REPLACEMENT OPERATIONS

< REMOVAL AND INSTALLATION >

[REGULAR GRADE]

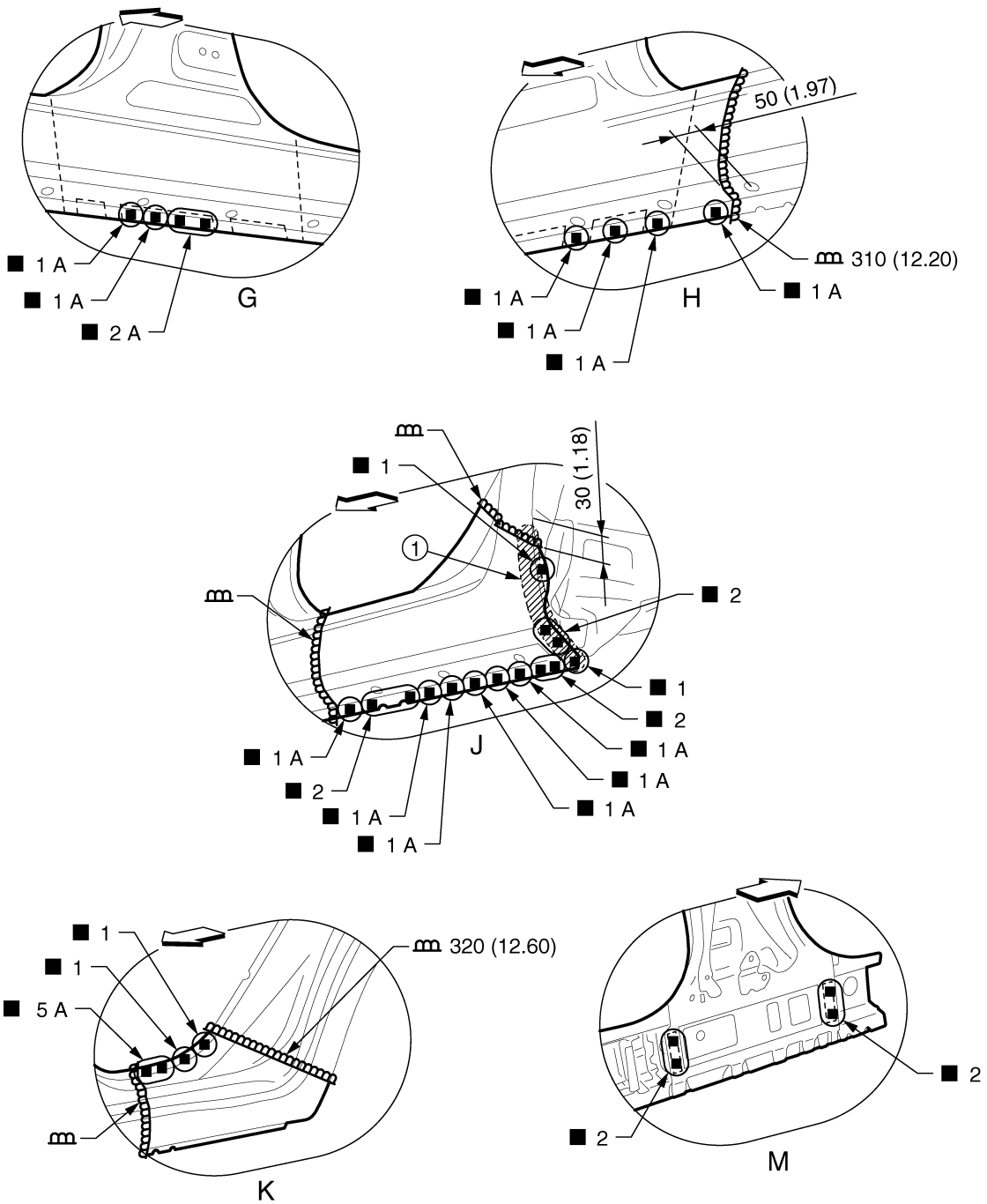

JSKIA1163GB

1. Body sealing

Unit: mm (in)

↔: Vehicle front

View M: Inner center pillar (replacement parts) and side body assembly (replacement parts)

# REPLACEMENT OPERATIONS

< REMOVAL AND INSTALLATION >

[REGULAR GRADE]

## Outer Sill (Partial Replacement)

INFOID:000000005094302

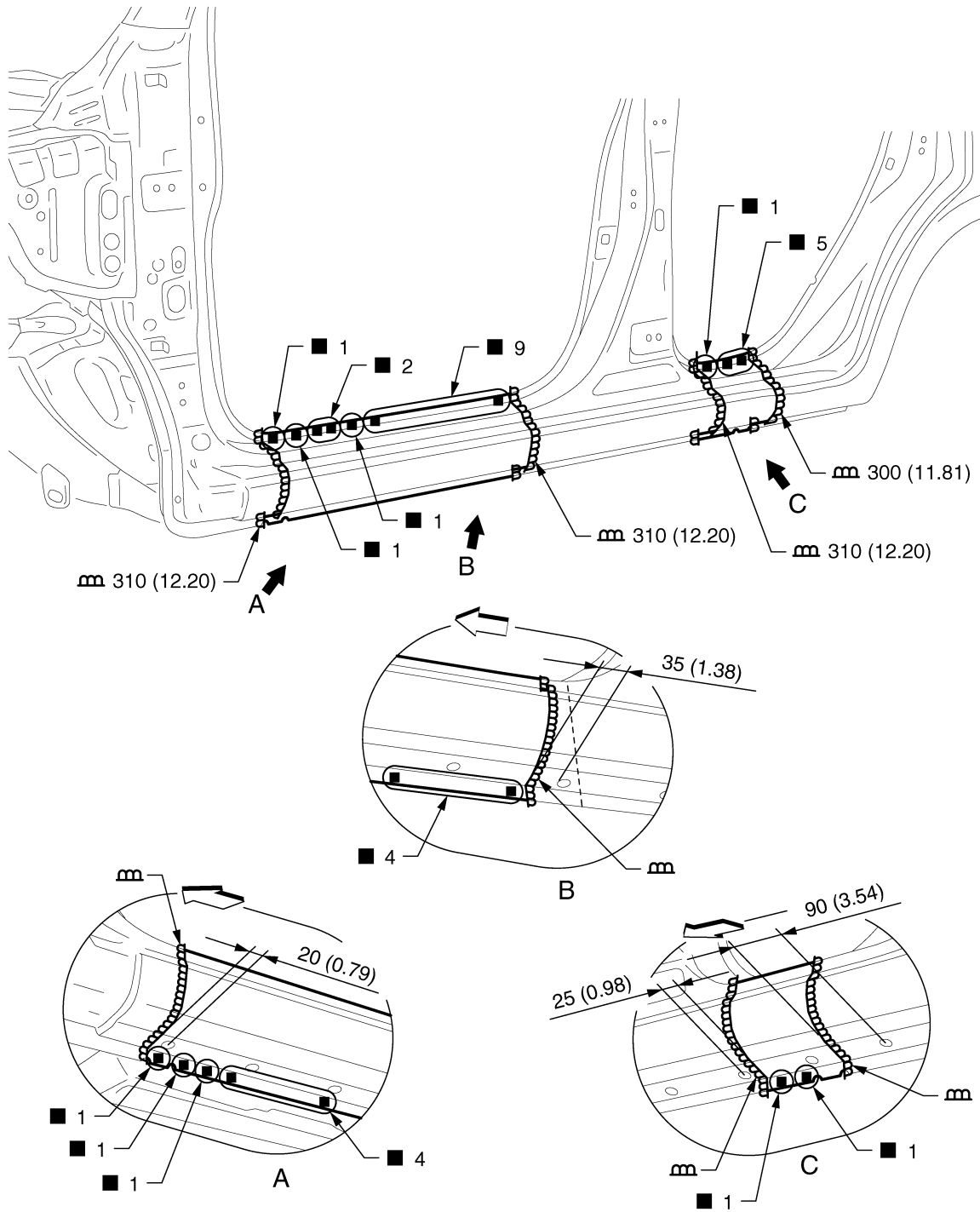

Unit: mm (in)

◀: Vehicle front

Replacement parts

- Outer sill (LH)

A  
B  
C  
D  
E  
F  
G  
H  
I  
J  
K  
L  
M  
N  
O  
P

BRM

JSKIA1164GB

# REPLACEMENT OPERATIONS

< REMOVAL AND INSTALLATION >

[REGULAR GRADE]

## Outer Sill

INFOID:000000005094304

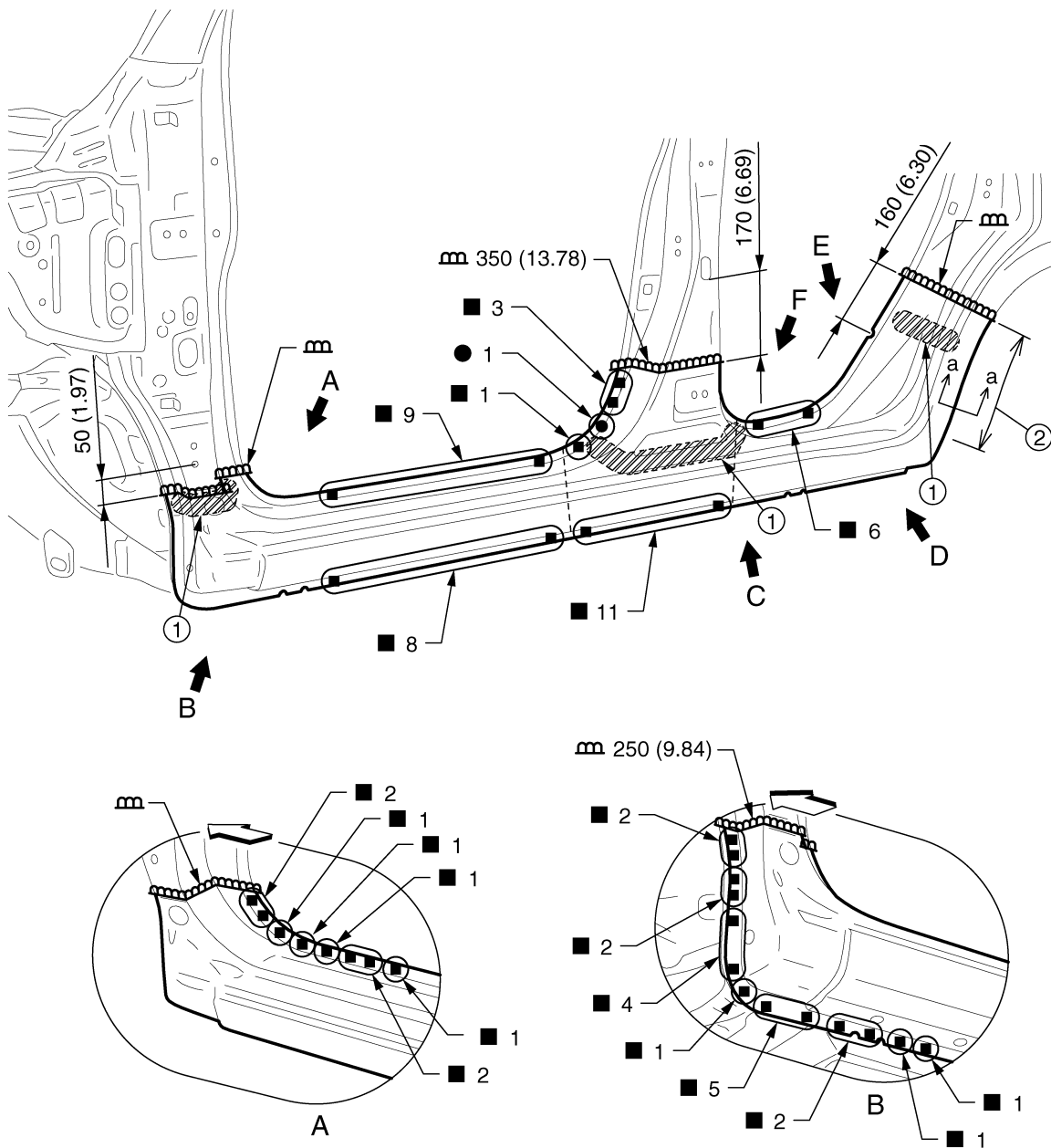

JSKIA1165GB

1. Urethane foam

2. Hemming portion

Unit: mm (in)

◁: Vehicle front

Replacement parts

● Outer sill (LH)

# REPLACEMENT OPERATIONS

< REMOVAL AND INSTALLATION >

[REGULAR GRADE]

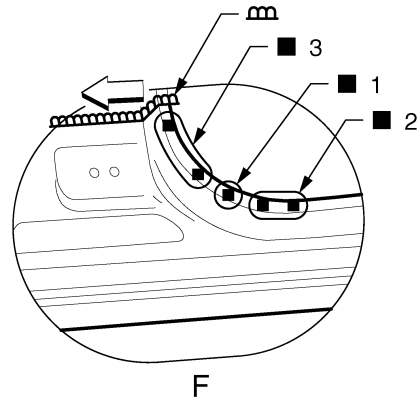
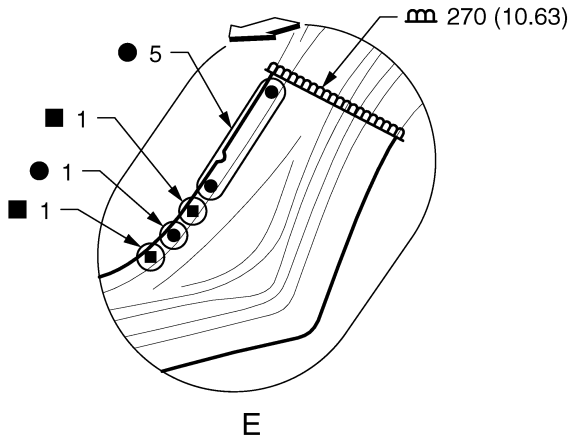
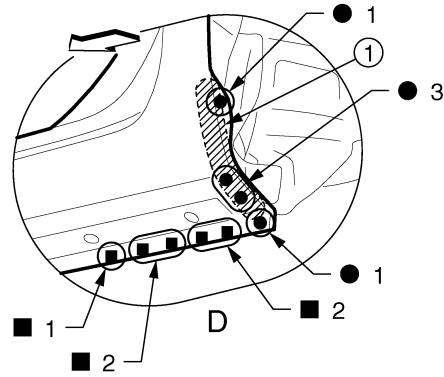
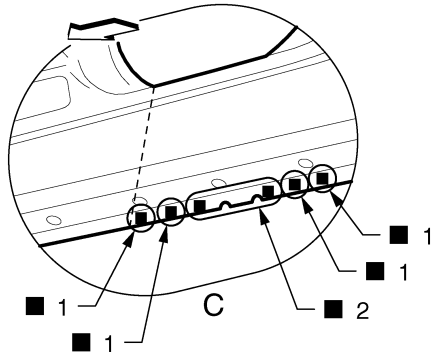

- 1. Body sealing
- Unit: mm (in)
- ←: Vehicle front

POINT

A  
B  
C  
D  
E  
F  
G  
H  
I  
J  
L  
M  
N  
O  
P

BRM

JSKIA1166GB

## REPLACEMENT OPERATIONS

< REMOVAL AND INSTALLATION >

[REGULAR GRADE]

- Perform the hemming to the flange of wheelarch after applying the adhesive.
- Apply the sealing to the flange end.
- Refer to [BRM-19. "Rear Fender Hemming Process"](#).

1. Outer rear wheelhouse
2. Rear fender
3. Adhesive
4. Sealant

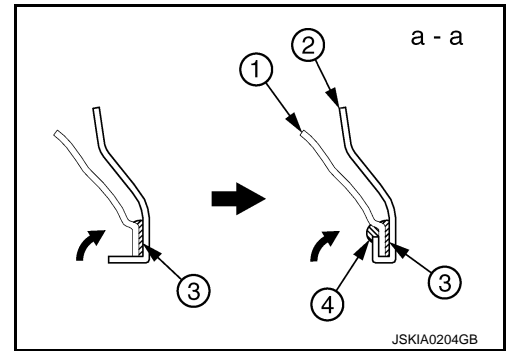



# REPLACEMENT OPERATIONS

< REMOVAL AND INSTALLATION >

[REGULAR GRADE]

## Rear Fender (LH)

INFOID:000000005094305

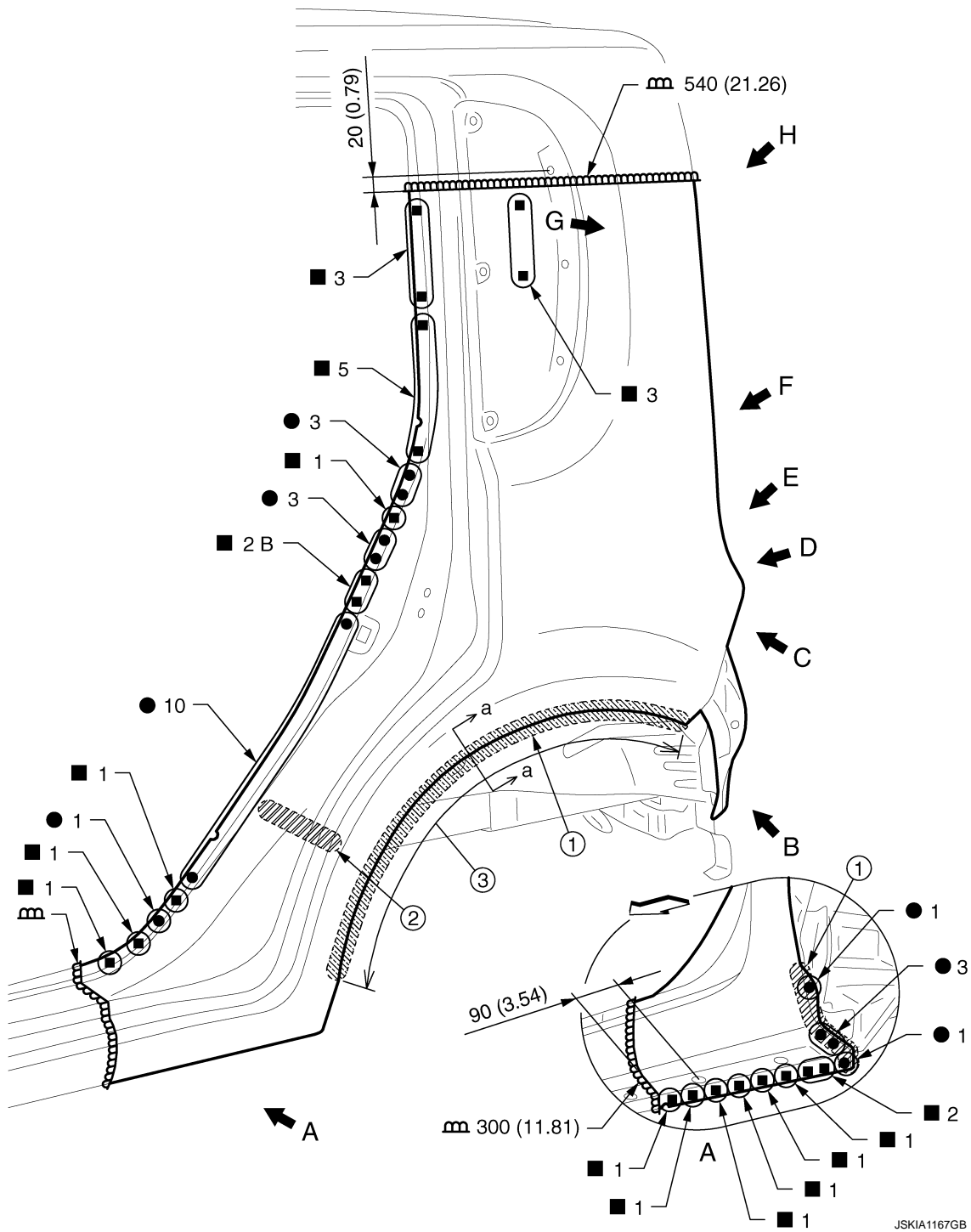

1. Adhesive

2. Urethane foam

3. Hemming portion

Unit: mm (in)

↔: Vehicle front

Replacement parts

● Rear fender assembly (LH)

● Back pillar assembly (LH)

JSKIA1167GB

A  
B  
C  
D  
E  
F  
G  
H  
I  
J  
K  
L  
M  
N  
O  
P

BRM

# REPLACEMENT OPERATIONS

< REMOVAL AND INSTALLATION >

[REGULAR GRADE]

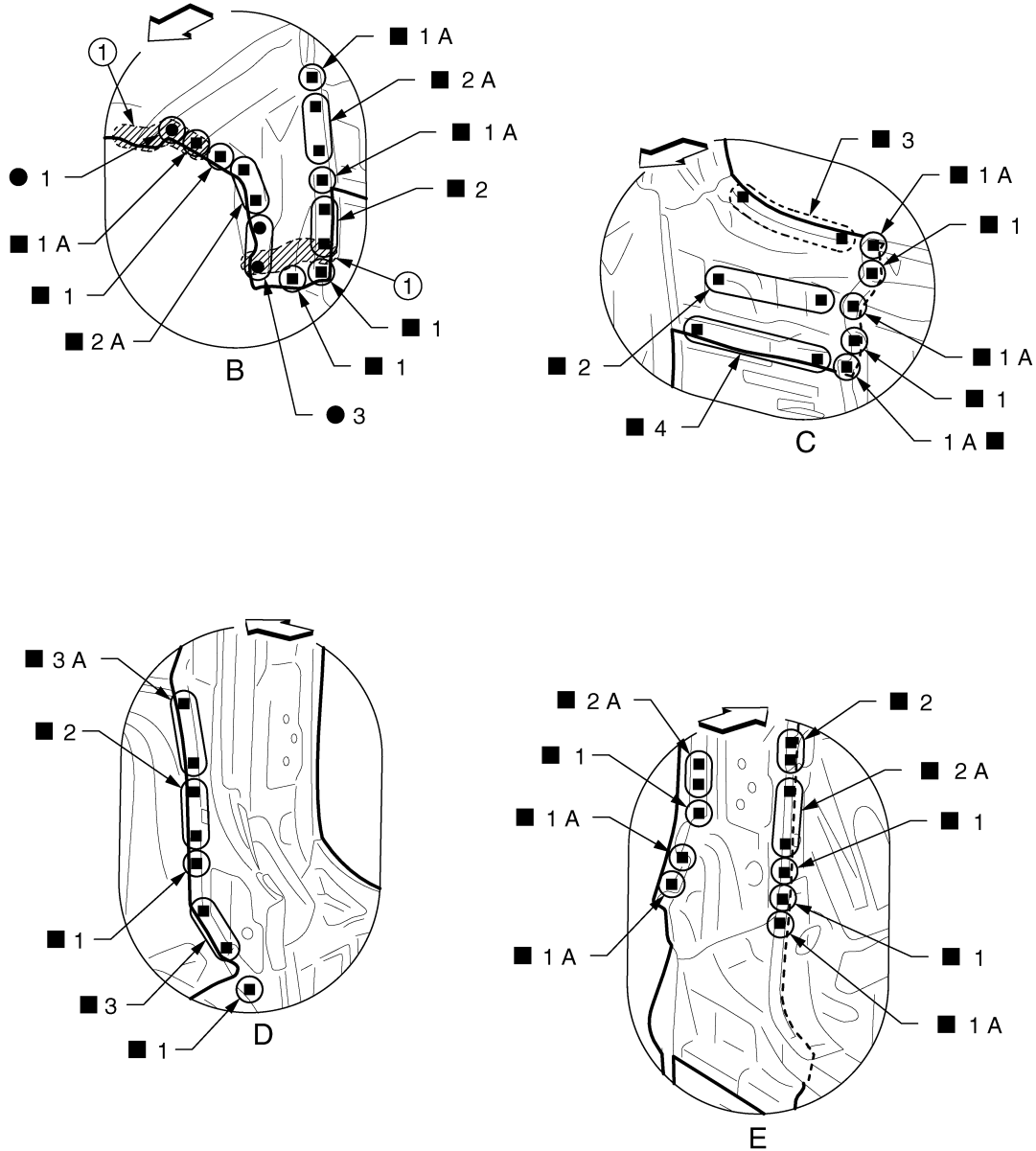

1. Body sealing

↔: Vehicle front

○: Weld the parts onto the back of the component part.

View D: Before installing rear fender assembly

JSKIA1168ZZ

# REPLACEMENT OPERATIONS

< REMOVAL AND INSTALLATION >

[REGULAR GRADE]

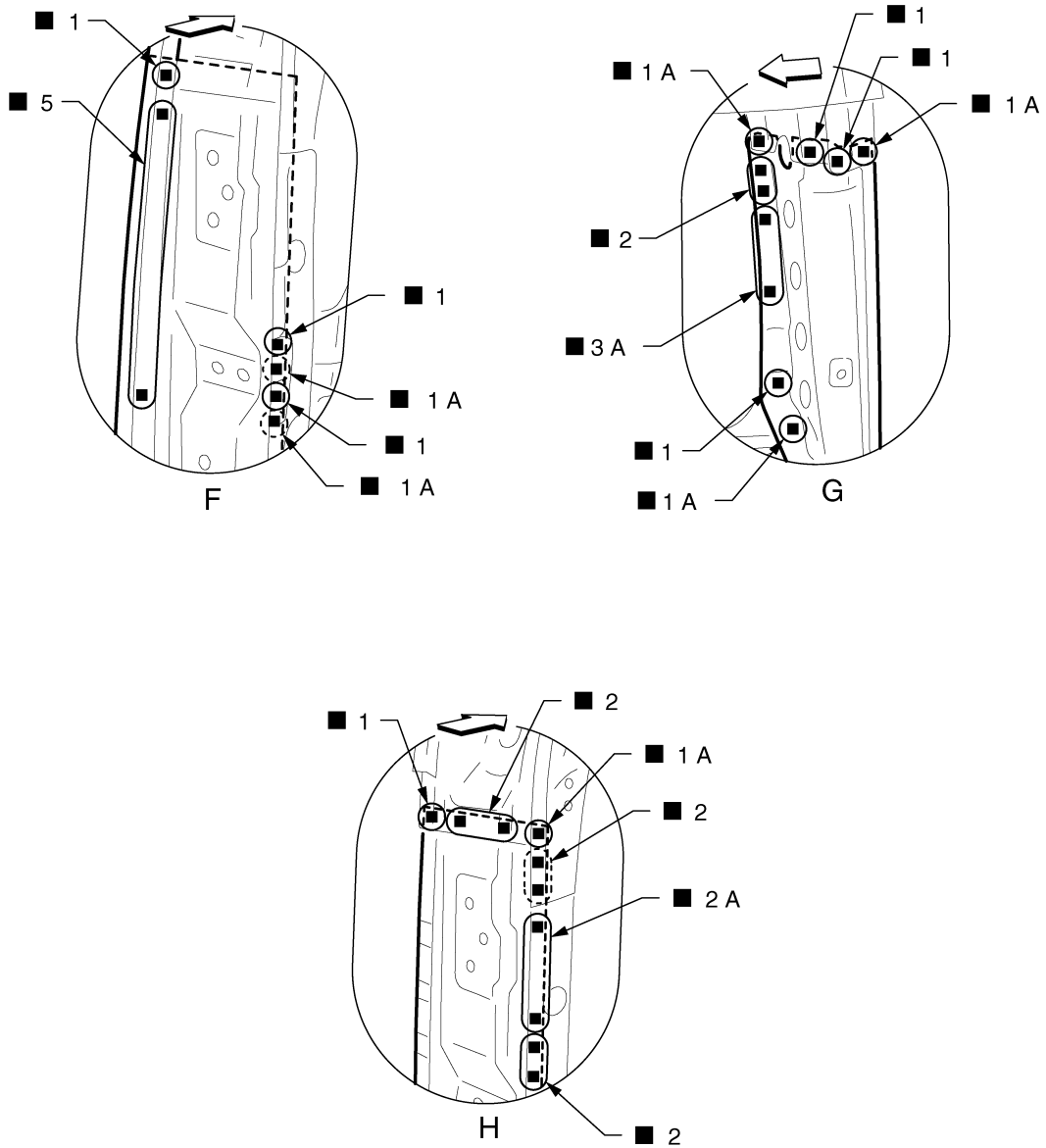

←: Vehicle front

○: Weld the parts onto the back of the component part.

View G and H: Before installing rear fender assembly

POINT

JSKIA1169ZZ

A  
B  
C  
D  
E  
F  
G  
H  
I  
J  
K  
L  
M  
N  
O  
P

BRM

## REPLACEMENT OPERATIONS

< REMOVAL AND INSTALLATION >

[REGULAR GRADE]

- Perform the hemming to the flange of wheelarch after applying the adhesive.
- Apply the sealing to the flange end.
- Refer to [BRM-19. "Rear Fender Hemming Process"](#).

1. **Outer rear wheelhouse**
2. **Rear fender**
3. **Adhesive**
4. **Sealant**

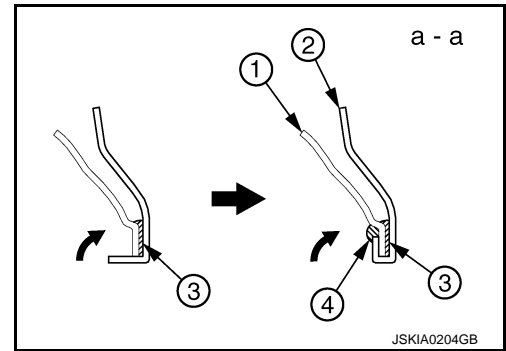

# REPLACEMENT OPERATIONS

< REMOVAL AND INSTALLATION >

[REGULAR GRADE]

## Rear Fender (RH)

INFOID:000000005128476

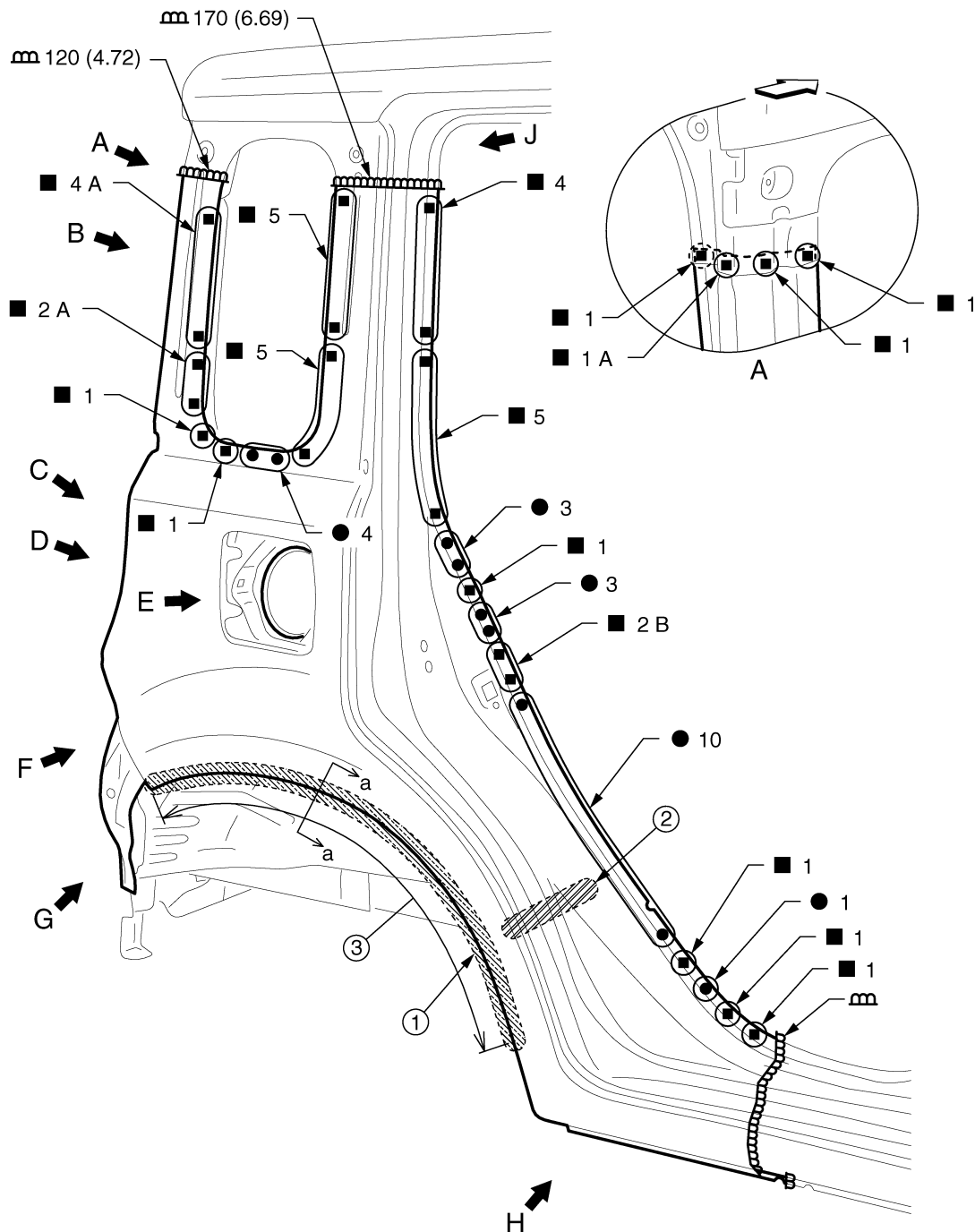

A  
B  
C  
D  
E  
F  
G  
H  
I  
J  
K  
L  
M  
N  
O  
P

BRM

- 1. Adhesive
- 2. Urethane foam
- 3. Hemming portion

Unit: mm (in)

←: Vehicle front

○: Weld the parts onto the back of the component part.

Replacement parts

- Rear fender assembly (RH)
- Back pillar assembly (RH)

View A: Before installing rear fender assembly

JSKIA1170GB

# REPLACEMENT OPERATIONS

< REMOVAL AND INSTALLATION >

[REGULAR GRADE]

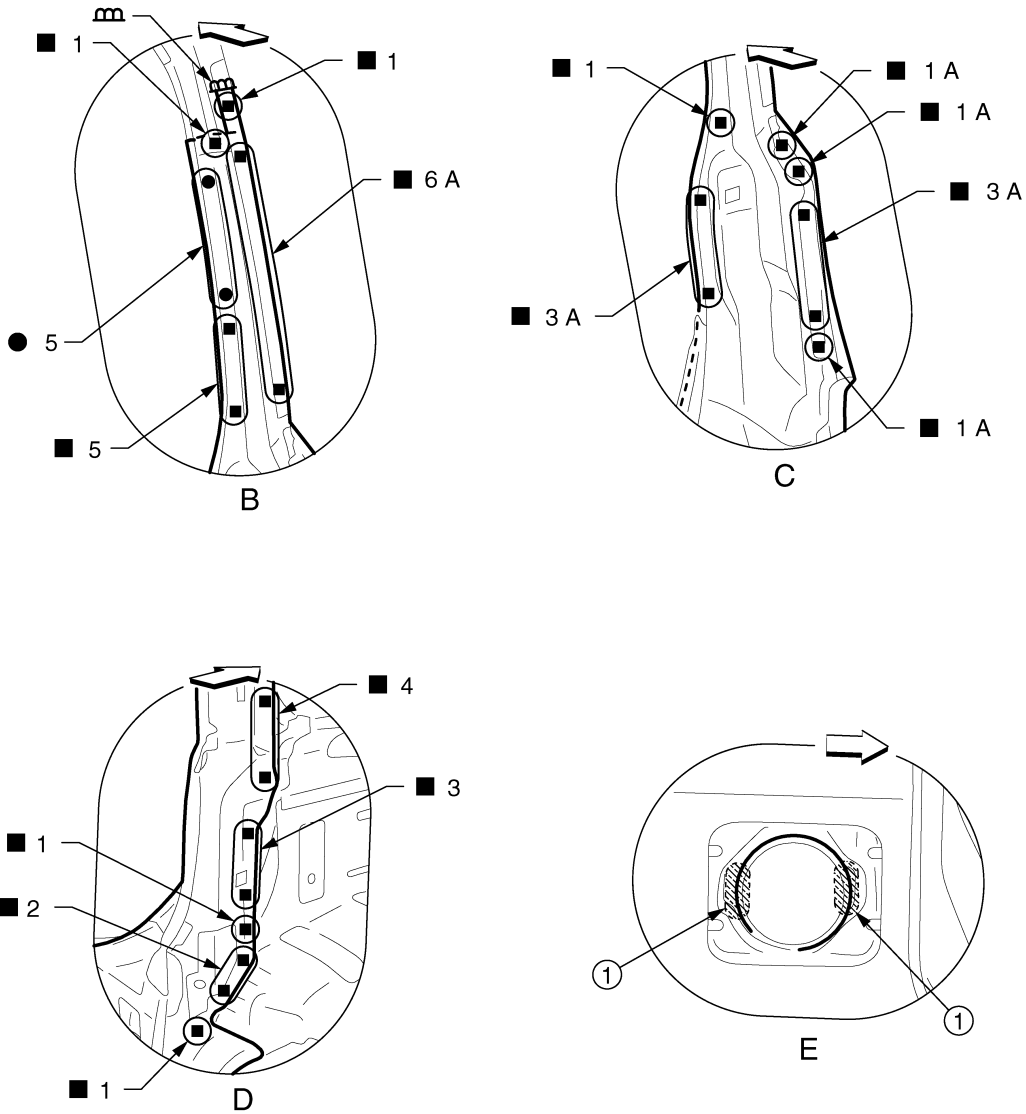

- 1. Adhesive
- ⇐: Vehicle front

View D: Before installing rear fender assembly

JSKIA1171ZZ

# REPLACEMENT OPERATIONS

< REMOVAL AND INSTALLATION >

[REGULAR GRADE]

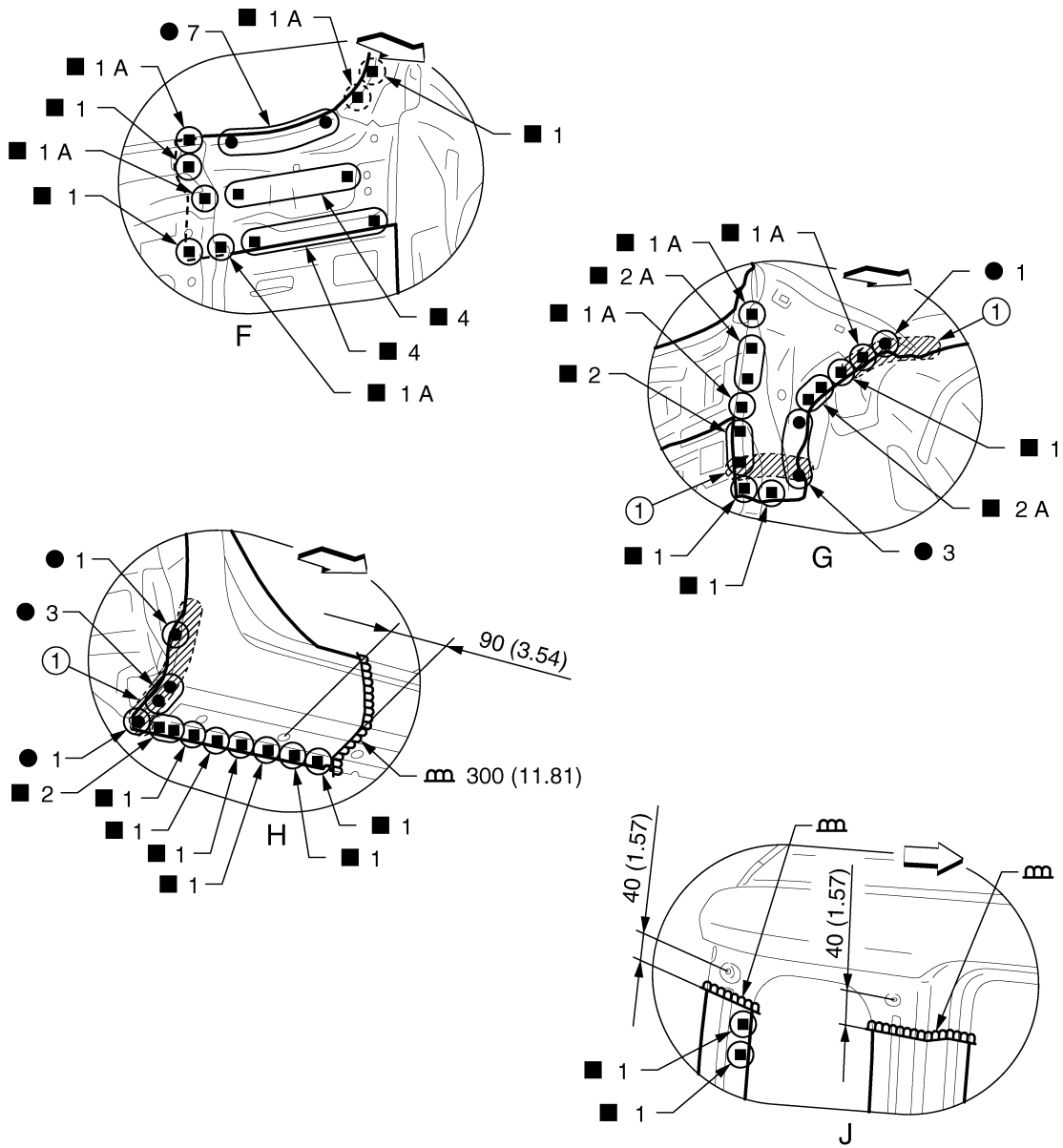

1. Body sealing

Unit: mm (in)

↔: Vehicle front

⊕: Weld the parts onto the back of the component part.

POINT

A  
B  
C  
D  
E  
F  
G  
H  
I  
J  
K  
L  
M  
N  
O  
P

BRM

JSKIA1172GB

## REPLACEMENT OPERATIONS

### < REMOVAL AND INSTALLATION >

[REGULAR GRADE]

- Perform the hemming to the flange of wheelarch after applying the adhesive.
- Apply the sealing to the flange end.
- Refer to [BRM-19. "Rear Fender Hemming Process"](#).

1. **Outer rear wheelhouse**
2. **Rear fender**
3. **Adhesive**
4. **Sealant**

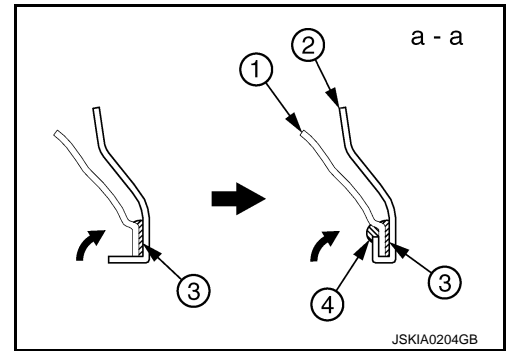



# REPLACEMENT OPERATIONS

< REMOVAL AND INSTALLATION >

[REGULAR GRADE]

## Rear Panel

INFOID:000000005094307

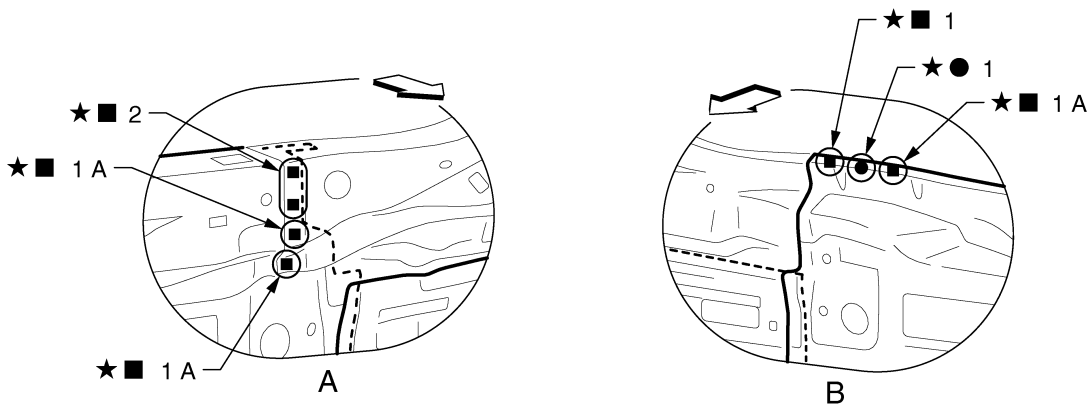
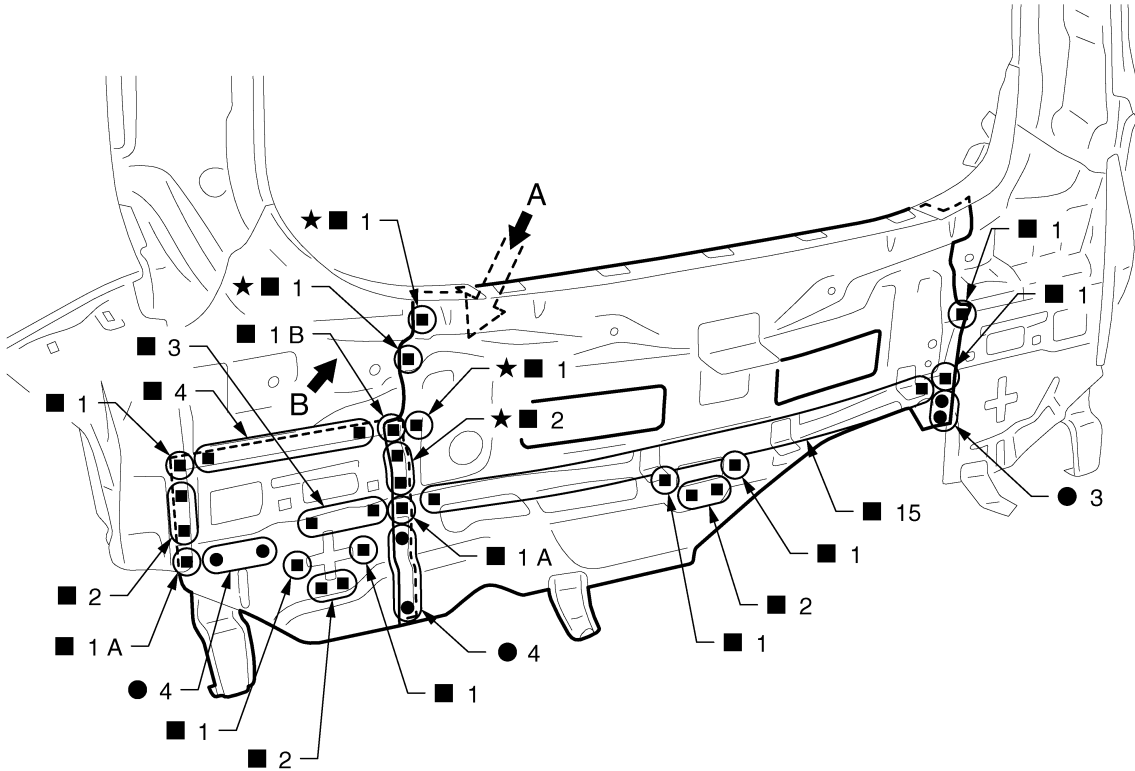

JSKIA1173ZZ

⇐: Vehicle front

★: An equivalent welding portion with the same dimensions is on the opposite side.

Replacement parts

● Rear panel assembly

● Rear combination lamp base extension (LH)

## Rear Floor Rear

INFOID:000000005094308

Work after rear panel is removed.

A  
B  
C  
D  
E  
F  
G  
H  
I  
J  
BRM  
L  
M  
N  
O  
P

# REPLACEMENT OPERATIONS

< REMOVAL AND INSTALLATION >

[REGULAR GRADE]

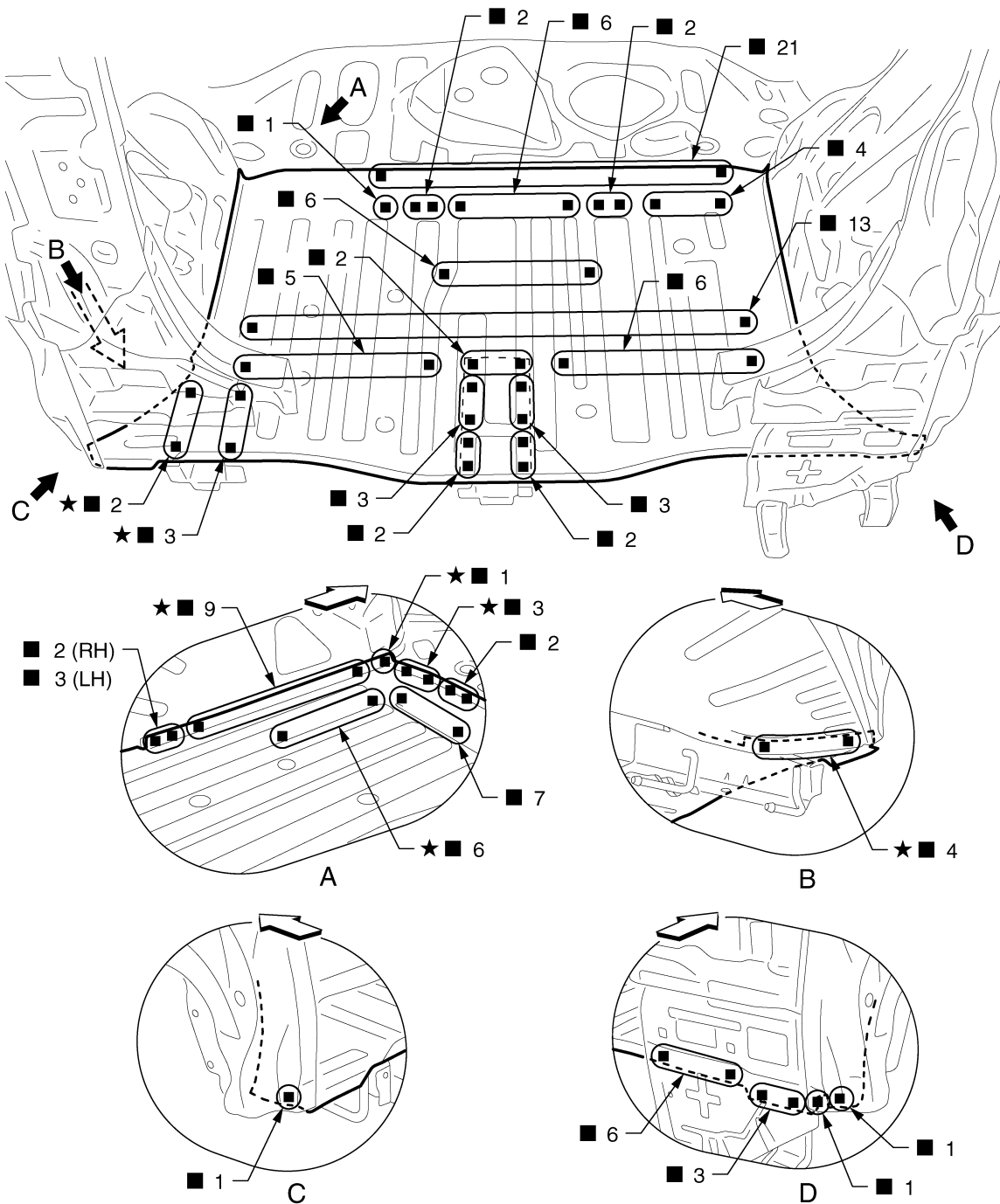

JSKIA1174GB

↔: Vehicle front

★: An equivalent welding portion with the same dimensions is on the opposite side.

Replacement parts

- Rear floor rear

## Rear Side Member Extension

INFOID:000000005094309

Work after rear panel is removed.  
Remove the welding point (a) for easier installation.

# REPLACEMENT OPERATIONS

< REMOVAL AND INSTALLATION >

[REGULAR GRADE]

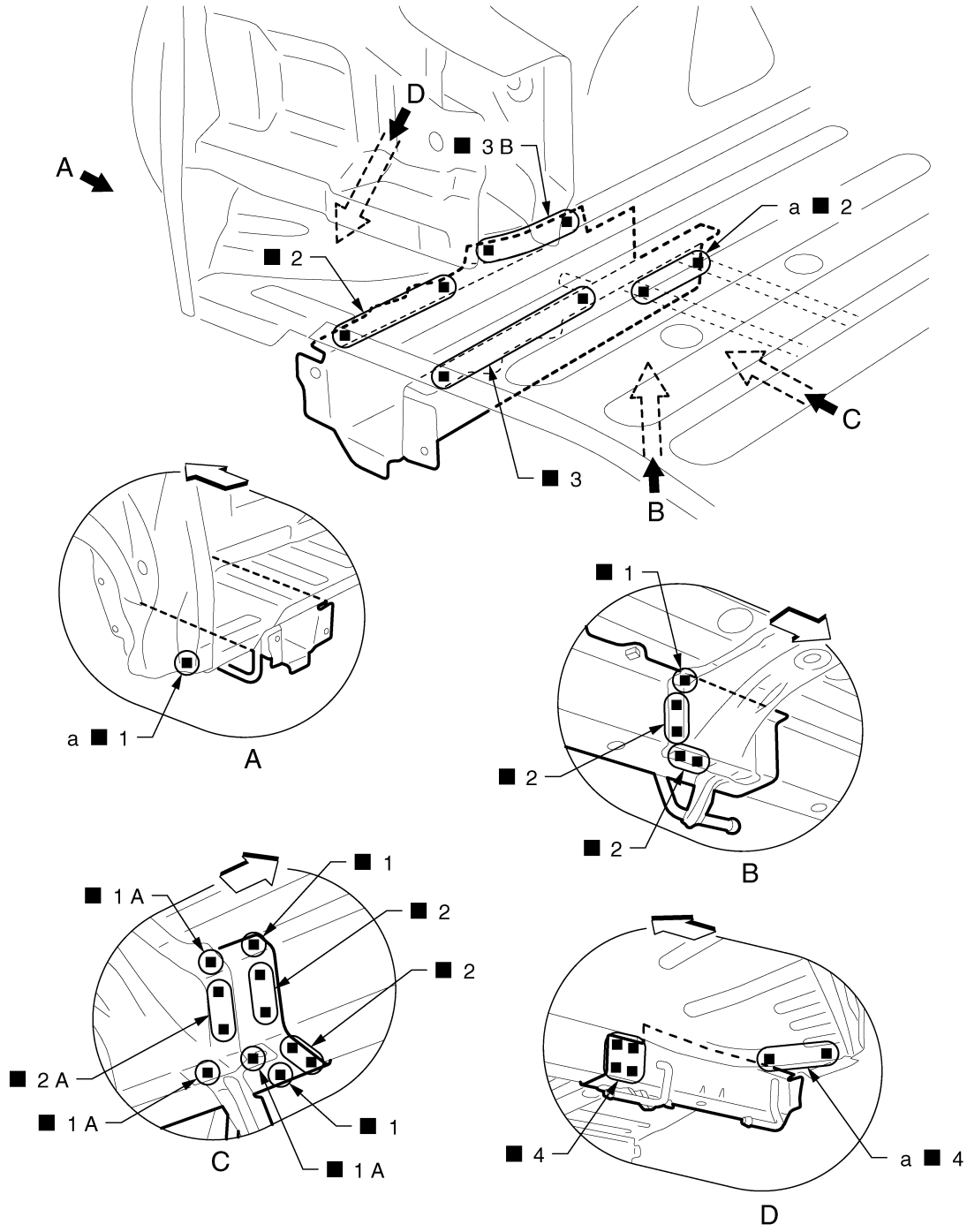

JSKIA1175ZZ

- ←: Vehicle front
- Replacement parts
- Rear side member extension (LH)

A  
B  
C  
D  
E  
F  
G  
H  
I  
J  
BRM  
L  
M  
N  
O  
P

# BODY ALIGNMENT

< SERVICE DATA AND SPECIFICATIONS (SDS)

[REGULAR GRADE]

## SERVICE DATA AND SPECIFICATIONS (SDS)

### BODY ALIGNMENT

#### Body Center Marks

INFOID:000000005094282

A mark is placed on each part of the body to indicate the vehicle center. When repairing the vehicle frame (members, pillars, etc.) damaged by an accident which it enables more accurate and effective repair by using these marks together with body alignment specifications.

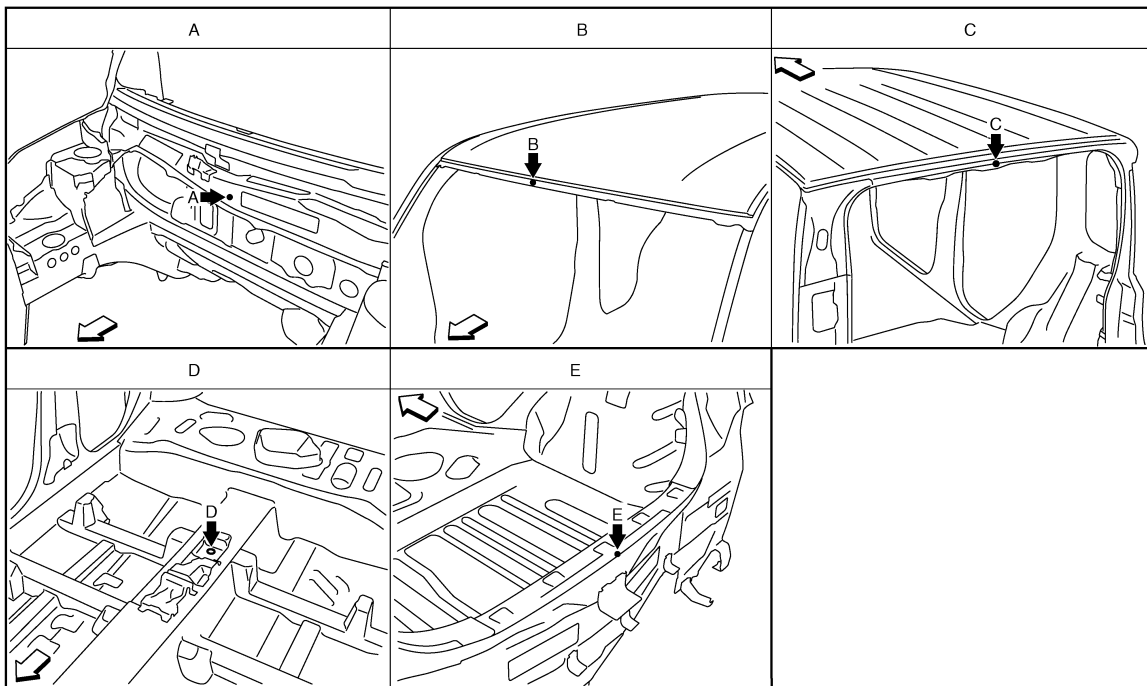
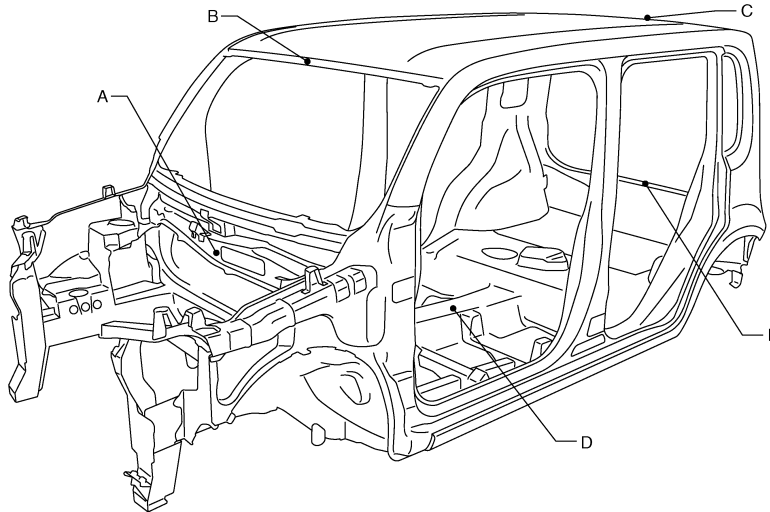

JSKIA1141ZZ

↶ : Vehicle front

Unit: mm (in)

Points	Portion	Marks
A	Cowl top	Embossment
B	Front roof	Embossment
C	Rear roof	Indent

# BODY ALIGNMENT

< SERVICE DATA AND SPECIFICATIONS (SDS)

[REGULAR GRADE]

Points	Portion	Marks
D	Parking brake reinforcement	Hole $\phi 12$ (0.47)
E	Rear panel	Indent

## Description

INFOID:000000005094283

- All dimensions indicated in the figures are actual.
- When using a tracking gauge, adjust both pointers to equal length. Then check the pointers and gauge itself to make sure there is no free play.
- When a measuring tape is used, check to be sure there is no elongation, twisting or bending.
- Measurements should be taken at the center of the mounting holes.
- An asterisk (\*) following the value at the measuring point indicates that the measuring point on the other side is symmetrically the same value.
- The coordinates of the measurement points are the distances measured from the standard line of "X", "Y" and "Z".
- "Z": Imaginary base line [200 mm (7.87 in) below datum line ("0Z" at design plan)]

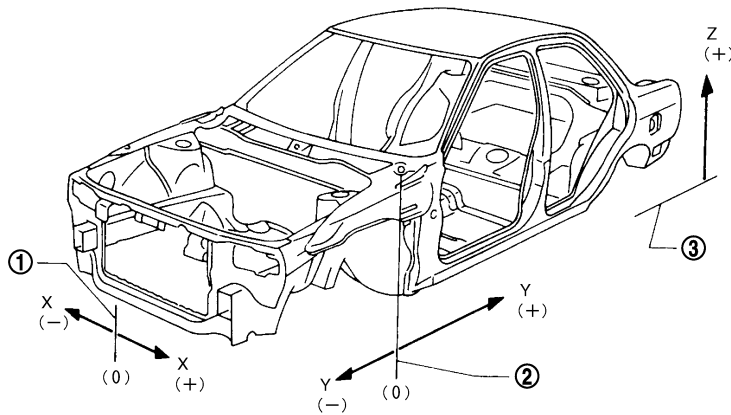

JSKIA0073GB

1. Vehicle center

2. Front axle center

3. Imaginary base line

## Engine Compartment

INFOID:000000005094284

### Measurement

Dimensions marked with "\*" indicate symmetrically identical dimensions on both the right and left hand of the vehicle.

A  
B  
C  
D  
E  
F  
G  
H  
I  
J  
L  
M  
N  
O  
P

BRM

# BODY ALIGNMENT

< SERVICE DATA AND SPECIFICATIONS (SDS)

[REGULAR GRADE]

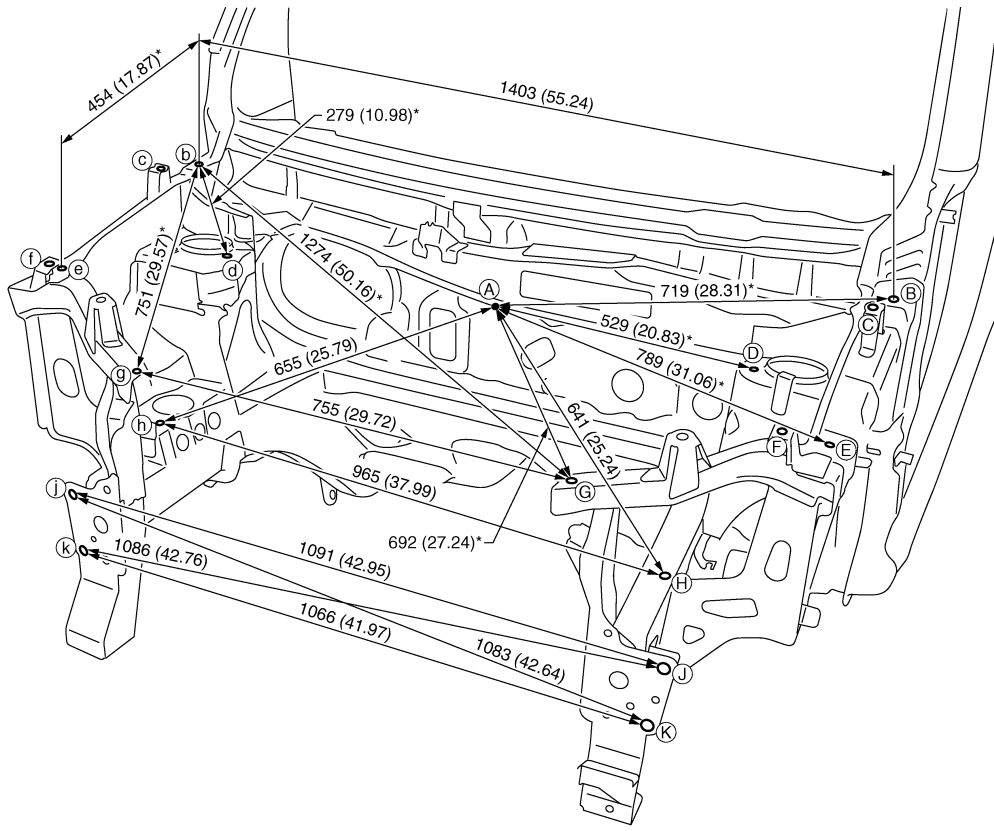

JSKIA1142GB

Unit: mm (in)

«The others»

Unit: mm (in)

Point	Dimension	Memo	Point	Dimension	Memo	Point	Dimension	Memo	Point	Dimension	Memo
A - C	711 (27.99)*		B - d	1238 (48.74)*		C - c	1377 (54.21)		F - f	1297 (51.06)	
A - F	800 (31.50)*		B - e	1473 (57.99)*		D - d	1037 (40.83)				
B - C	159 (6.26)*		B - F	547 (21.54)*		E - e	1400 (55.12)				

## Measurement Points

# BODY ALIGNMENT

< SERVICE DATA AND SPECIFICATIONS (SDS)

[REGULAR GRADE]

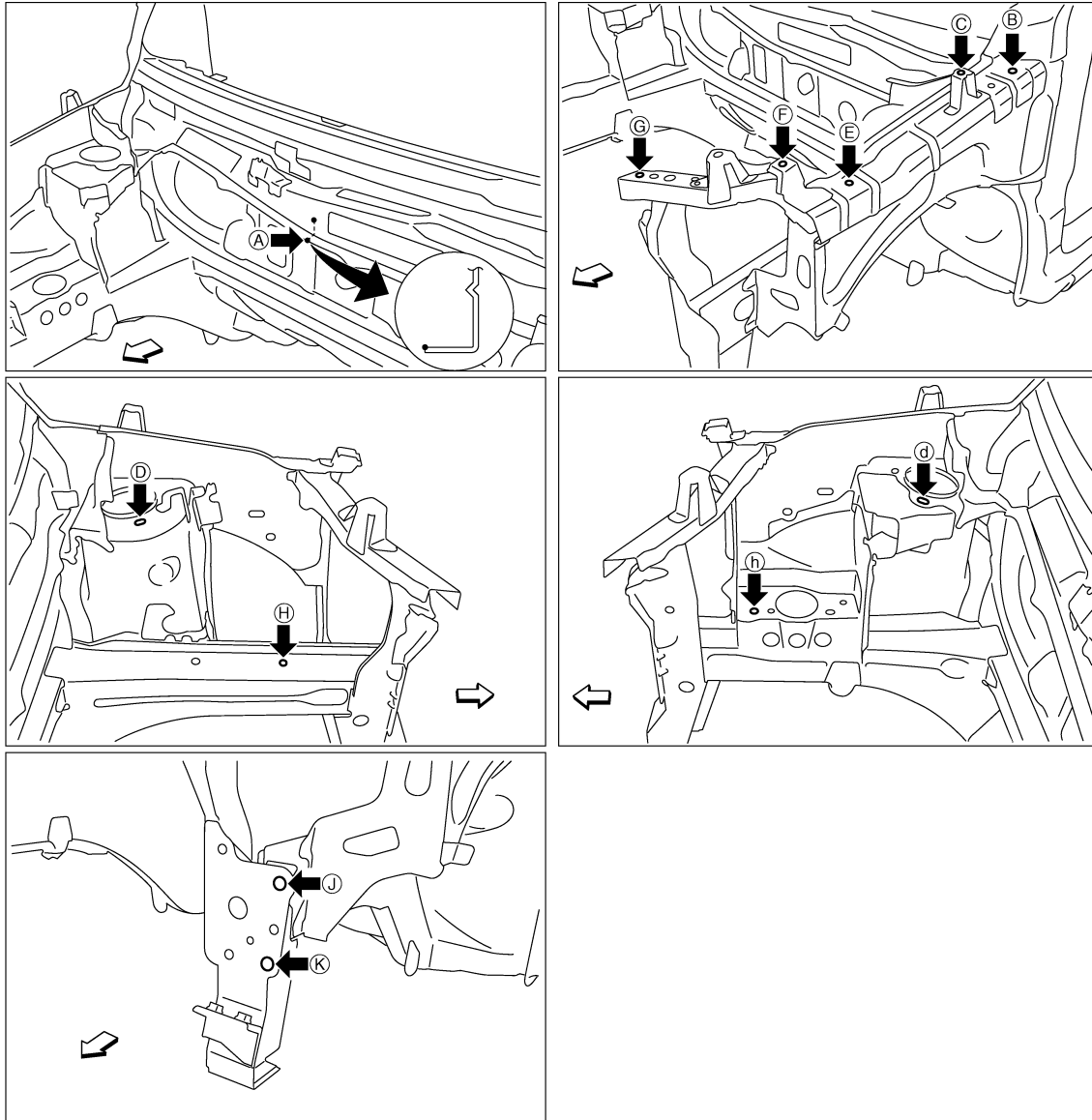

A  
B  
C  
D  
E  
F  
G  
H  
I  
J

**BRM**

L  
M

JSKIA1143ZZ

↶ : Vehicle front

Unit: mm (in)

Point	Material	Point	Material
A	Cowl top flange end of center positioning mark	G, g	Upper radiator core support hole center $\phi 9$ (0.35)
B, b	Hood hinge installing hole center $\phi 11$ (0.43)	H	Front side member hole center $\phi 11$ (0.43)
C, c, F, f	Front fender installing hole center $\phi 7$ (0.28)	h	Engine mounting bracket hole center $\phi 11$ (0.43)
D, d	Front strut installing hole center 11×16 (0.43×0.63)	J, j	Front side member reinforcement extension hole center J: $\phi 14$ (0.55) j: 10×14 (0.39×0.55)
E, e	Hoodledge reinforcement hole center $\phi 12$ (0.47)	K, k	Front side member connector hole center $\phi 16$ (0.63)

N  
O  
P

## Underbody

INFOID:000000005094285

## Measurement

# BODY ALIGNMENT

< SERVICE DATA AND SPECIFICATIONS (SDS)

[REGULAR GRADE]

Dimensions marked with "\*" indicate symmetrically identical dimensions on both the right and left hand of the vehicle.

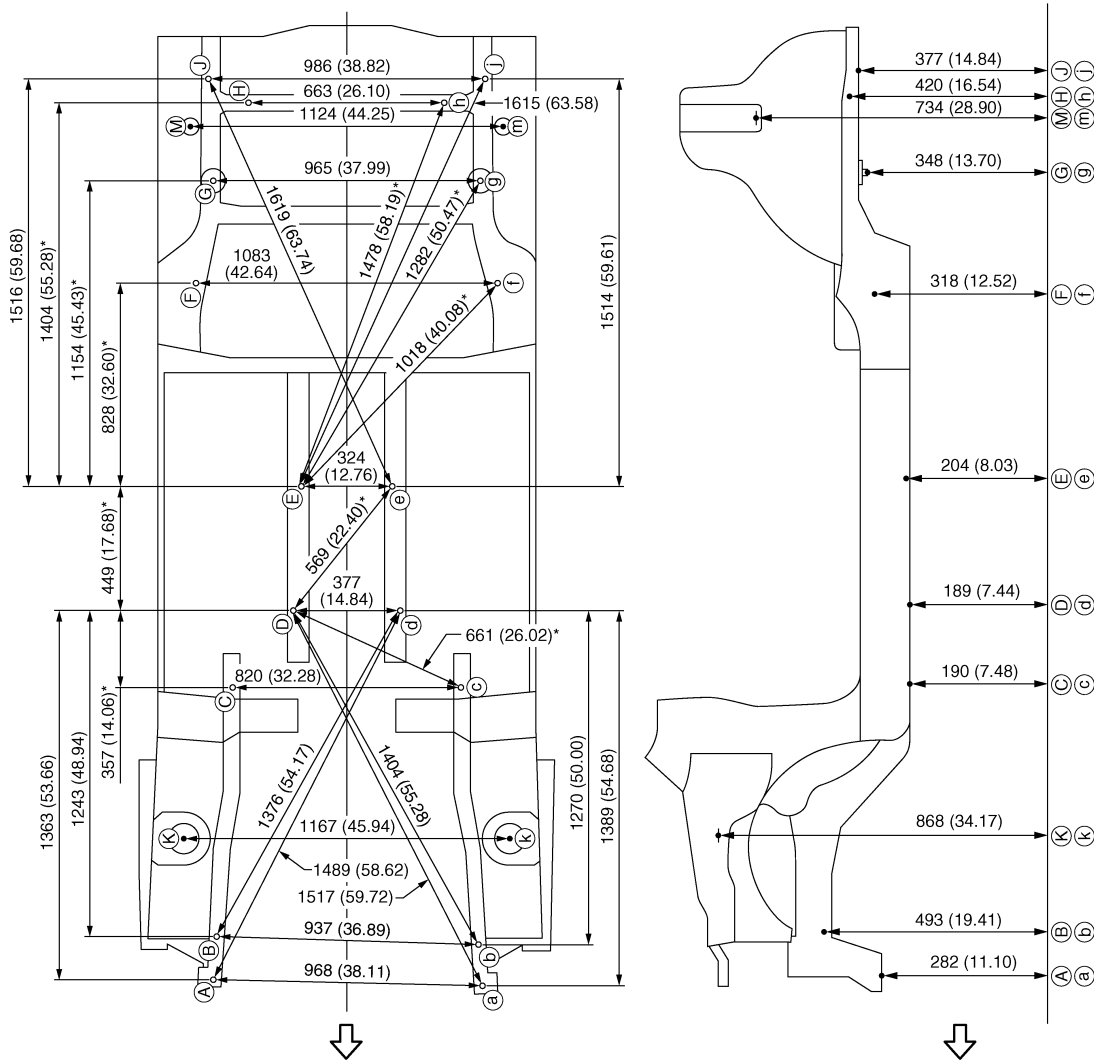

JSKIA1144GB

Unit: mm (in)

↔ : Vehicle front

## Measurement Points



# BODY ALIGNMENT

< SERVICE DATA AND SPECIFICATIONS (SDS)

[REGULAR GRADE]

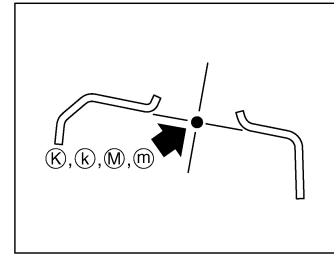
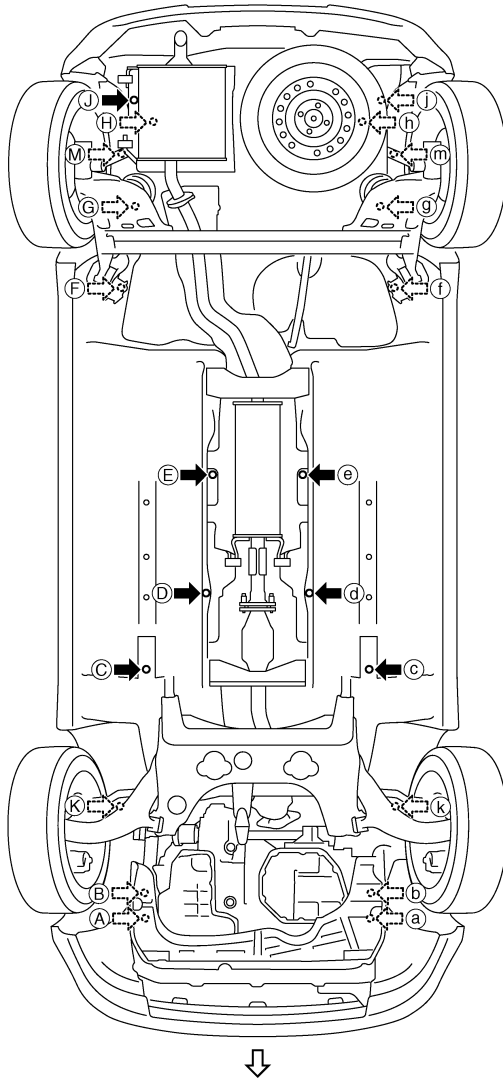

JSKIA1145ZZ

↶ : Vehicle front

Unit: mm (in)

Points	Coordinates			Remarks	Points	Coordinates			Remarks
	X	Y	Z			X	Y	Z	
A	476.0 (18.740)	-502.0 (-19.764)	282.0 (11.102)	Hole $\phi$ 11 (0.43)	G, g	$\pm$ 482.3 ( $\pm$ 18.988)	2374.2 (93.472)	348.3 (13.713)	Hole $\phi$ 12 (0.47)
a	-492.0 (-19.370)	-525.0 (-20.669)	282.0 (11.102)	Hole $\phi$ 11 (0.43)	H	331.3 (13.043)	2651.5 (104.390)	419.8 (16.528)	Hole $\phi$ 16 (0.63)
B	462.4 (18.205)	-346.0 (-13.622)	492.8 (19.402)	Hole $\phi$ 16 (0.63)	h	-331.3 (-13.043)	2651.5 (104.390)	419.8 (16.528)	Hole 16×18 (0.63×0.71)
b	-474.7 (-18.689)	-372.0 (-14.646)	492.8 (19.402)	Hole $\phi$ 16 (0.63)	J	498.0 (19.606)	2743.0 (107.992)	376.8 (14.835)	Hole $\phi$ 16 (0.63)
C, c	$\pm$ 410.0 ( $\pm$ 16.142)	547.0 (21.535)	190.2 (7.488)	Hole $\phi$ 16 (0.63)	j	-487.5 (-19.193)	2743.0 (107.992)	376.8 (14.835)	Hole 17×16 (0.67×0.63)
D, d	$\pm$ 188.7 ( $\pm$ 7.429)	827.5 (32.579)	189.0 (7.441)	Hole $\phi$ 8 (0.31)	K, k	$\pm$ 583.6 ( $\pm$ 22.976)	6.6 (0.260)	868.0 (34.173)	Hole $\phi$ 98 (3.86)

A  
B  
C  
D  
E  
F  
G  
H  
I  
J  
K  
L  
M  
N  
O  
P

BRM

# BODY ALIGNMENT

< SERVICE DATA AND SPECIFICATIONS (SDS)

[REGULAR GRADE]

Points	Coordinates			Remarks	Points	Coordinates			Remarks
	X	Y	Z			X	Y	Z	
E, e	±162.0 (±6.378)	1275.0 (50.197)	204.0 (8.031)	Hole $\phi$ 21 (0.83)	M, m	±561.9 (±22.122)	2569.2 (101.149)	734.4 (28.913)	Hole $\phi$ 20 (0.79)
F, f	±541.3 (±21.311)	2002.4 (78.834)	318.0 (12.520)	Hole $\phi$ 16 (0.63)					

## Passenger Compartment

INFOID:000000005094286

### Measurement

Dimensions marked with "\*" indicate symmetrically identical dimensions on both the right and left hand of the vehicle.

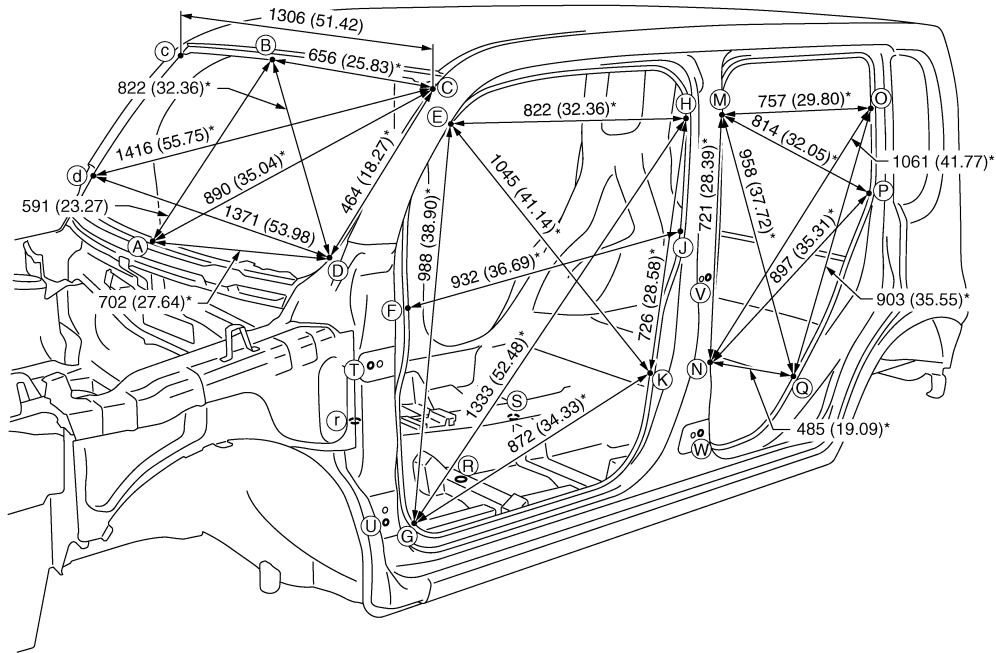

JSKIA1146GB

Unit: mm (in)

«The others»

# BODY ALIGNMENT

< SERVICE DATA AND SPECIFICATIONS (SDS)

[REGULAR GRADE]

Unit: mm (in)

Point	Dimension	Memo	Point	Dimension	Memo	Point	Dimension	Memo	Point	Dimension	Memo
E - e	1367 (53.82)		J - j	1385 (54.53)		O - o	1340 (52.76)		S - N	778 (30.63)*	
E - g	1689 (66.50)*		K - k	1368 (53.86)		O - q	1627 (64.05)*		S - O	1571 (61.85)*	
E - h	1607 (63.27)*		M - m	1392 (54.80)		P - p	1371 (53.98)		S - P	1407 (55.39)*	
E - k	1721 (67.76)*		M - n	1554 (61.18)*		Q - q	1367 (53.82)		S - Q	961 (37.83)*	
F - f	1346 (52.99)		M - o	1562 (61.50)*		R - E	1291 (50.83)*		T - V	1159 (45.63)*	
F - j	1653 (65.08)*		M - p	1603 (63.11)*		R - F	988 (38.90)*		T - W	1207 (47.52)*	
G - g	1373 (54.06)		M - q	1680 (66.14)*		R - G	712 (28.03)*		U - V	1213 (47.76)*	
G - h	1921 (75.63)*		N - n	1361 (53.58)		R - H	1275 (50.20)*		U - W	1106 (43.54)*	
G - k	1624 (63.94)*		N - o	1717 (67.60)*		R - J	1008 (39.68)*				
H - h	1394 (54.88)		N - p	1634 (64.33)*		R - K	687 (27.05)*				
H - k	1560 (61.42)*		N - q	1448 (57.01)*		S - M	1278 (50.31)*				

## Measurement Points

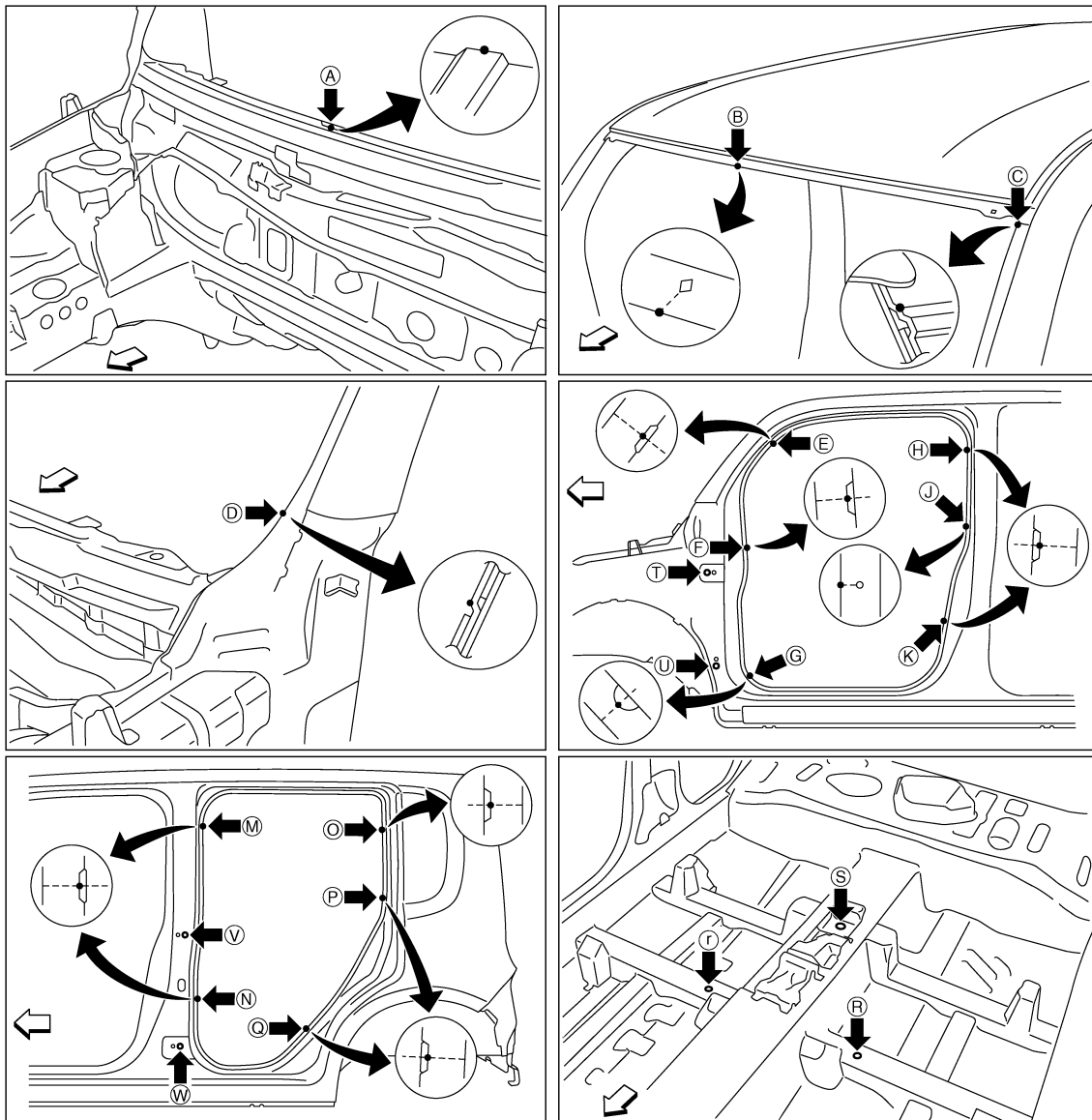

A  
B  
C  
D  
E  
F  
G  
H  
I  
J  
L  
M  
N  
O  
P

BRM

JSKIA1147ZZ

# BODY ALIGNMENT

< SERVICE DATA AND SPECIFICATIONS (SDS)

[REGULAR GRADE]

↶ : Vehicle front

Unit: mm (in)

Point	Material	Point	Material
A	Cowl top flange	J, j	Center pillar flange
B	Roof flange end of center positioning mark	O, o, P, p, Q, q	Rear fender indent
C, c	Front pillar joggle	R, r	2nd crossmember hole center 12×14 (0.47×0.55)
D, d	Upper inner front pillar joggle	S	Parking brake reinforcement hole center of center positioning mark $\phi 12$ (0.47)
E, e, F, f, G, g	Front pillar indent	T, t, U, u, V, v, W, w	Door hinge installing hole center T, t, U, u, W, w: $\phi 12$ (0.47) V, v: $\phi 9$ (0.35)
H, h, K, k, M, m, N, n	Center pillar indent		

## Rear Body

INFOID:000000005094287

### Measurement

Dimensions marked with "\*" indicate symmetrically identical dimensions on both the right and left hand of the vehicle.

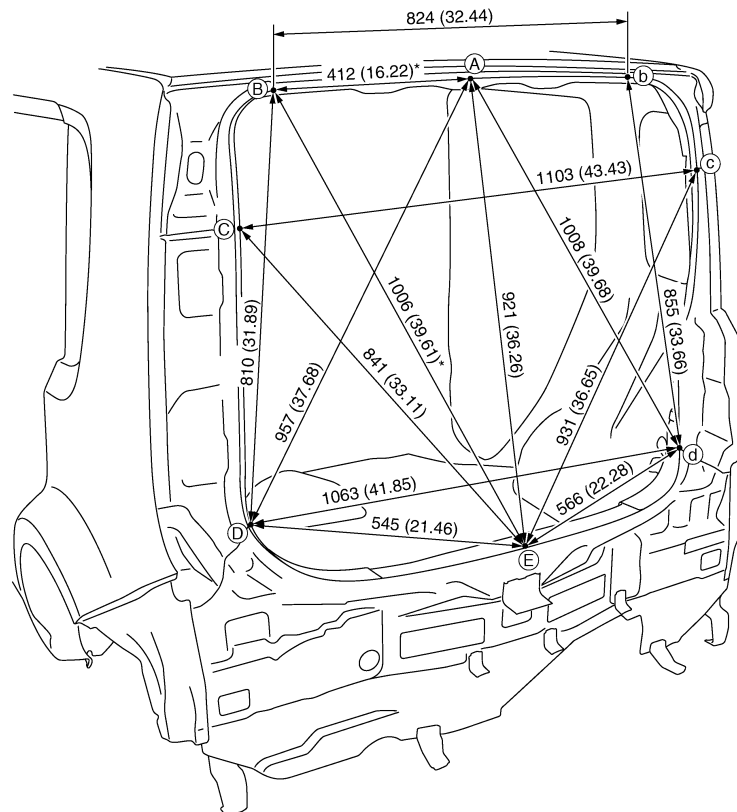

JSKIA1148GB

Unit: mm (in)

«The others»

# BODY ALIGNMENT

< SERVICE DATA AND SPECIFICATIONS (SDS)

[REGULAR GRADE]

Unit: mm (in)

Point	Dimension	Memo	Point	Dimension	Memo	Point	Dimension	Memo	Point	Dimension	Memo
A - C	566 (22.28)		b - C	952 (37.48)		C - D	555 (21.85)		c - D	1261 (49.65)	
A - c	631 (24.84)		B - d	1277 (50.28)		c - d	639 (25.16)				
B - c	1028 (40.47)		b - D	1227 (48.31)		C - d	1210 (47.64)				

## Measurement Points

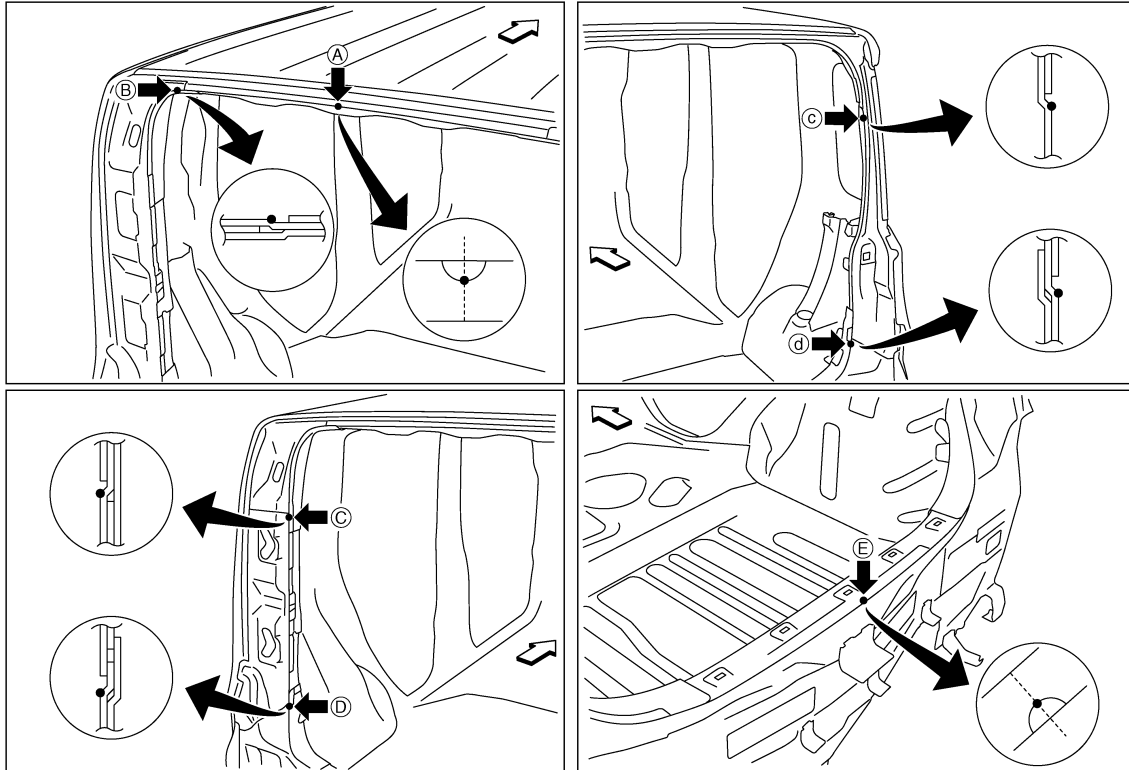

JSKIA1149ZZ

↶ : Vehicle front

Point	Material	Point	Material
A	Roof flange end of center positioning mark	D, d	Rear combination lamp base joggle
B, b	Upper outer back pillar joggle	E	Rear panel indent of center positioning mark
C, c	Lower outer back pillar joggle		

# LOCATION OF PLASTIC PARTS

< SERVICE DATA AND SPECIFICATIONS (SDS)

[REGULAR GRADE]

## LOCATION OF PLASTIC PARTS

### Precautions for Plastics

INFOID:000000005094288

Abbreviation	Material name	Heatresisting temperature °C (°F)	Resistance to gasoline and solvents	Other cautions
PE	Polyethylene	60 (140)	Gasoline and most solvents are harmless if applied for a very short time (wipe out quickly).	Flammable
ABS	Acrylonitrile Butadiene Styrene	80 (176)	Avoid gasoline and solvents.	—
EPM/EPDM	Ethylene Propylene (Diene) copolymer	80 (176)	Gasoline and most solvents are harmless if applied for a very short time (wipe out quickly).	Flammable
PS	Polystyrene	80 (176)	Avoid solvents.	Flammable
PVC	Poly Vinyl Chloride	80 (176)	Gasoline and most solvents are harmless if applied for a very short time (wipe out quickly).	Poisonous gas is emitted when burned.
TPO	Thermoplastic Olefine	80 (176)	↑	Flammable
AAS	Acrylonitrile Acrylic Styrene	85 (185)	Avoid gasoline and solvents.	—
PMMA	Poly Methyl Methacrylate	85 (185)	↑	—
EVAC	Ethylene Vinyl Acetate	90 (194)	↑	—
PP	Polypropylene	90 (194)	Gasoline and most solvents are harmless if applied for a very short time (wipe out quickly).	Flammable, avoid battery acid.
PUR	Polyurethane	90 (194)	Avoid gasoline and solvents.	—
UP	Unsaturated Polyester	90 (194)	↑	Flammable
ASA	Acrylonitrile Styrene Acrylate	100 (212)	↑	Flammable
PPE	Poly Phenylene Ether	110 (230)	↑	—
TPU	Thermoplastic Urethane	110 (230)	↑	—
PBT+PC	Poly Butylene Terephthalate + Polycarbonate	120 (248)	↑	Flammable
PC	Polycarbonate	120 (248)	↑	—
POM	Poly Oxymethylene	120 (248)	↑	Avoid battery acid.
PA	Polyamide	140 (284)	↑	Avoid immersing in water.
PBT	Poly Butylene Terephthalate	140 (284)	↑	—
PAR	Polyarylate	180 (356)	↑	—
PET	Polyethylene terephthalate	180 (356)	↑	—
PEI	Polyetherimide	200 (392)	↑	—

**CAUTION:**

- When repairing and painting a portion of the body adjacent to plastic parts, consider their characteristics (influence of heat and solvent) and remove them if necessary or take suitable measures to protect them.
- Plastic parts should be repaired and painted using methods suiting the materials' characteristics.

# LOCATION OF PLASTIC PARTS

< SERVICE DATA AND SPECIFICATIONS (SDS)

[REGULAR GRADE]

## Location of Plastic Parts

INFOID:000000005094289

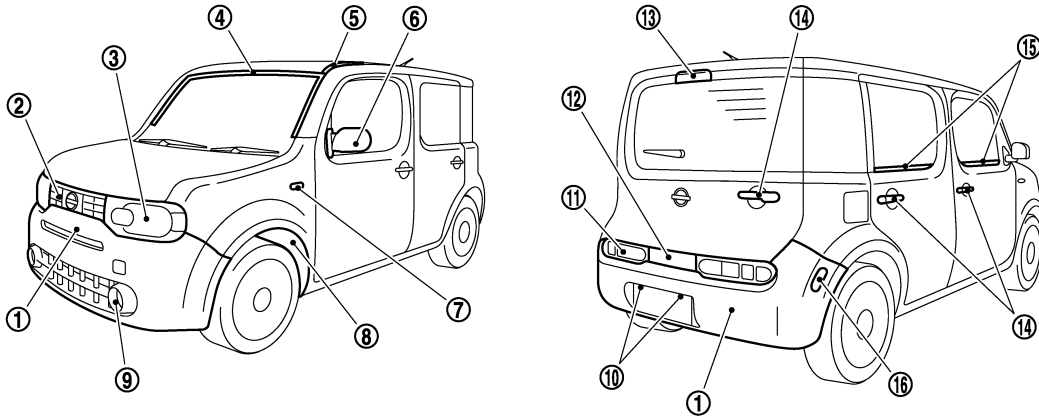

JSKIA1179ZZ

Component		Material	Component		Material		
1	Bumper fascia	PP + EPM	10	License plate lamp	Lens	PMMA	
2	Front grille	ABS			Housing	PC	
3	Front combination lamp	Lens	11	Rear combination lamp	Lens	PMMA	
		Housing			PP	Housing	ASA
4	Windshield molding	PVC	12	Back door finisher	Lens	PMMA	
5	Roof side molding	PVC			Housing	ASA	
6	Door outside mirror	Cover (Material color)	13	High mount stop lamp	Lens	PC	
		Cover (Body color)			ABS	Housing	PC
		Base			PBT + PET + Glass fiber	14 Door outside handle	
7	Side turn signal lamp	Lens	PMMA	15 Door outside molding		PVC + Stainless	
		Housing	PC + ABS	16	Rear side marker lamp	Lens	PMMA
8	Front fender protector	PP	Housing			ASA	
9	Front fog lamp	Lens	Glass				
		Housing	PBT + ASA + Glass fiber				

A  
B  
C  
D  
E  
F  
G  
H  
I  
J  
K  
L  
M  
N  
O  
P

BRM

# LOCATION OF PLASTIC PARTS

< SERVICE DATA AND SPECIFICATIONS (SDS)

[REGULAR GRADE]

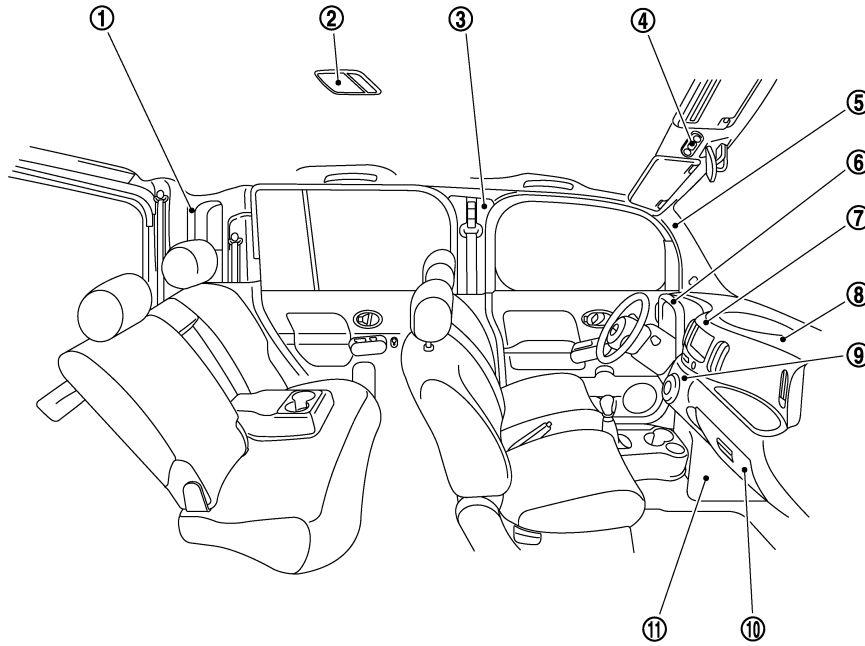

JSKIA1180ZZ

Component		Material	Component		Material
1	Rear pillar finisher	PP	6	Cluster lid A	PP
2	Room lamp	PC	7	Cluster lid C	PC + ABS
	Lens	PP	8	Instrument panel	PP
3	Center pillar garnish	PP	9	Air conditioner control finisher	PC + ABS
4	Map lamp	PC	10	Glove box	PP
	Lens	PA	11	Instrument lower cover	PP
5	Front pillar garnish	PP			



# BODY EXTERIOR PAINT COLOR

[Krom]

< SPEC CHANGE INFORMATION >

## SPEC CHANGE INFORMATION

### BODY EXTERIOR PAINT COLOR

Body Exterior Paint Color (Krom)

INFOID:000000005156116

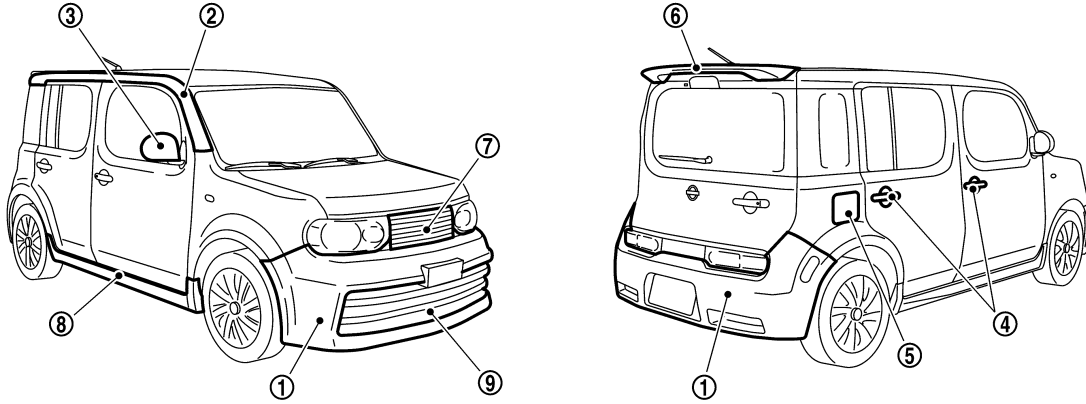

JKKIA0009ZZ

Component		Color code	BQX1	BK21	BKH3	BL50	
		Description	White	Gray	Black	Brownish Purple	
		Paint type <sup>note</sup>	3P	FPM	2S	P	
		Hard clear coat	-	-	-	-	
1	Bumper fascia	Body color	BQX1	BK21	BKH3	BL50	
2	Front pillar finisher	Body color	BQX1	BK21	BKH3	BL50	
3	Door outside mirror	Cover	Body color	BQX1	BK21	BKH3	BL50
4	Door outside handle	Body color	BQX1	BK21	BKH3	BL50	
5	Fuel filler lid	Body color	BQX1	BK21	BKH3	BL50	
6	Roof spoiler	Body color	BQX1	BK21	BKH3	BL50	
7	Front grille	Chromium plate	Cr	Cr	Cr	Cr	
8	Side sill extensions	Body color	BQX1	BK21	BKH3	BL50	
9	Bumper grille	Chromium plate	Cr	Cr	Cr	Cr	

**NOTE:**

- 2S: Solid + Clear
- CS: Color clear solid
- M: Metallic
- P: 2-Coat pearl
- 3P: 3-Coat pearl
- FPM: Iron oxide pearl
- RPM: Multi flex color
- TPM: Titanium pearl metallic
- TM: Micro titanium metallic
- PM: Pearl metallic

A  
B  
C  
D  
E  
F  
G  
H  
I  
J  
L  
M  
N  
O  
P

BRM

# LOCATION OF PLASTIC PARTS

< SERVICE DATA AND SPECIFICATIONS (SDS)

[Krom]

## SERVICE DATA AND SPECIFICATIONS (SDS)

### LOCATION OF PLASTIC PARTS

#### Precautions for Plastics

INFOID:000000005185540

Abbreviation	Material name	Heatresisting temperature °C (°F)	Resistance to gasoline and solvents	Other cautions
PE	Polyethylene	60 (140)	Gasoline and most solvents are harmless if applied for a very short time (wipe out quickly).	Flammable
ABS	Acrylonitrile Butadiene Styrene	80 (176)	Avoid gasoline and solvents.	—
EPM/EPDM	Ethylene Propylene (Diene) copolymer	80 (176)	Gasoline and most solvents are harmless if applied for a very short time (wipe out quickly).	Flammable
PS	Polystyrene	80 (176)	Avoid solvents.	Flammable
PVC	Poly Vinyl Chloride	80 (176)	Gasoline and most solvents are harmless if applied for a very short time (wipe out quickly).	Poisonous gas is emitted when burned.
TPO	Thermoplastic Olefine	80 (176)	↑	Flammable
AAS	Acrylonitrile Acrylic Styrene	85 (185)	Avoid gasoline and solvents.	—
PMMA	Poly Methyl Methacrylate	85 (185)	↑	—
EVAC	Ethylene Vinyl Acetate	90 (194)	↑	—
PP	Polypropylene	90 (194)	Gasoline and most solvents are harmless if applied for a very short time (wipe out quickly).	Flammable, avoid battery acid.
PUR	Polyurethane	90 (194)	Avoid gasoline and solvents.	—
UP	Unsaturated Polyester	90 (194)	↑	Flammable
ASA	Acrylonitrile Styrene Acrylate	100 (212)	↑	Flammable
PPE	Poly Phenylene Ether	110 (230)	↑	—
TPU	Thermoplastic Urethane	110 (230)	↑	—
PBT+PC	Poly Butylene Terephthalate + Polycarbonate	120 (248)	↑	Flammable
PC	Polycarbonate	120 (248)	↑	—
POM	Poly Oxymethylene	120 (248)	↑	Avoid battery acid.
PA	Polyamide	140 (284)	↑	Avoid immersing in water.
PBT	Poly Butylene Terephthalate	140 (284)	↑	—
PAR	Polyarylate	180 (356)	↑	—
PET	Polyethylene terephthalate	180 (356)	↑	—
PEI	Polyetherimide	200 (392)	↑	—

**CAUTION:**

- When repairing and painting a portion of the body adjacent to plastic parts, consider their characteristics (influence of heat and solvent) and remove them if necessary or take suitable measures to protect them.
- Plastic parts should be repaired and painted using methods suiting the materials' characteristics.

# LOCATION OF PLASTIC PARTS

< SERVICE DATA AND SPECIFICATIONS (SDS)

[Krom]

## Location of Plastic Parts (Krom)

INFOID:000000005156115

A  
B  
C  
D  
E  
F  
G  
H  
I  
J  
BRM  
L  
M  
N  
O  
P

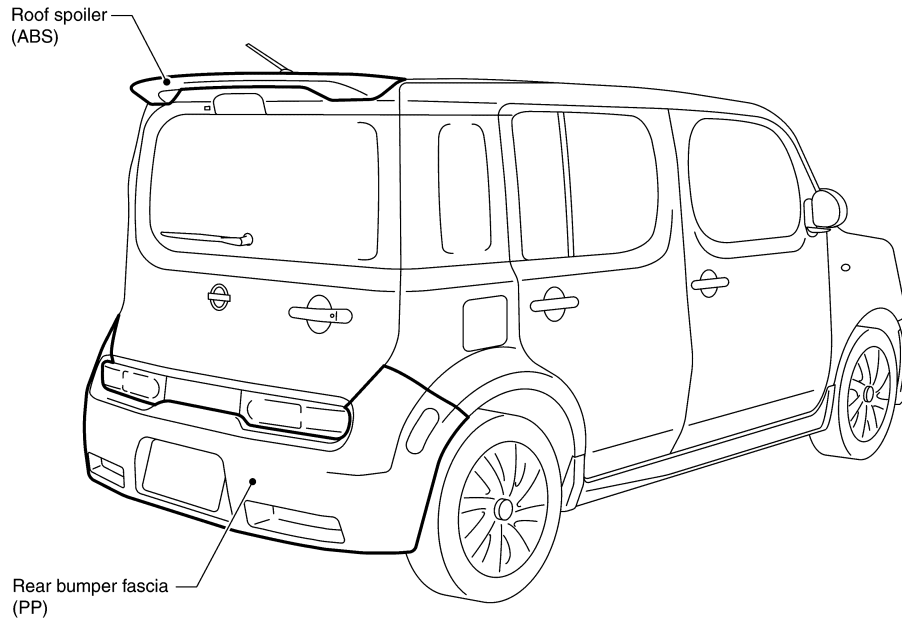
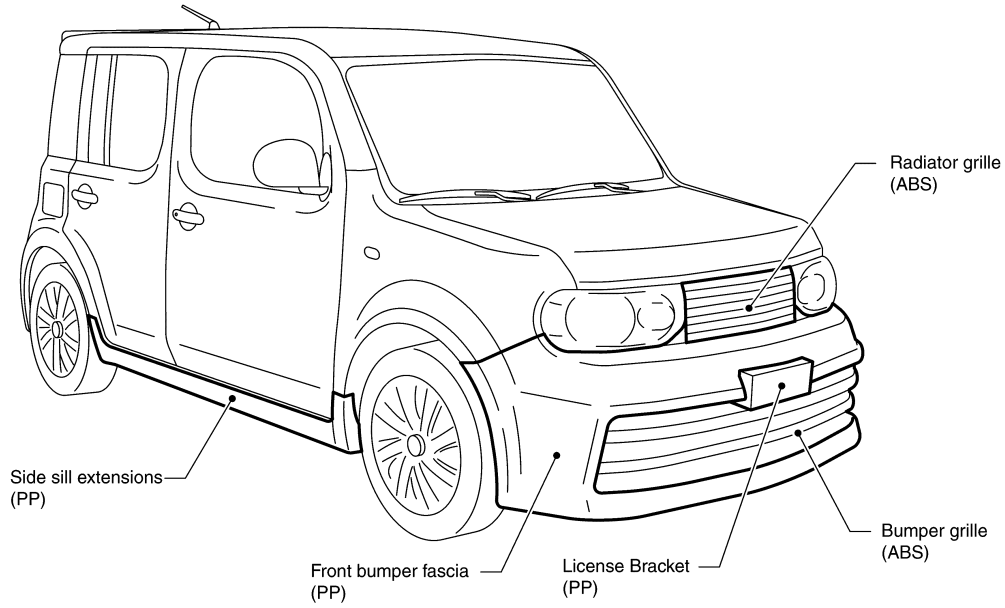

JKKIA0008GB