

SECTION **DEF**
DEFOGGER

A
B
C
D
E
F
G
H
I
J
K
DEF
M
N
O
P

CONTENTS

BASIC INSPECTION	4	WITHOUT INTELLIGENT KEY	17
DIAGNOSIS AND REPAIR WORK FLOW	4	WITHOUT INTELLIGENT KEY : Diagnosis De-	17
Work Flow	4	WITHOUT INTELLIGENT KEY : CONSULT-III	19
SYSTEM DESCRIPTION	5	Function (IPDM E/R)	19
REAR WINDOW DEFOGGER SYSTEM	5	DTC/CIRCUIT DIAGNOSIS	21
System Diagram	5	POWER SUPPLY AND GROUND CIRCUIT	21
System Description	5	BCM (BODY CONTROL SYSTEM) (WITH INTEL-	21
Component Parts Location	6	LIGENT KEY SYSTEM)	21
Component Description	6	BCM (BODY CONTROL SYSTEM) (WITH INTEL-	21
DIAGNOSIS SYSTEM (BCM) (WITH INTELLI-	7	LIGENT KEY SYSTEM) : Diagnosis Procedure	21
GENENT KEY SYSTEM)	7	BCM (BODY CONTROL SYSTEM) (WITHOUT IN-	21
COMMON ITEM	7	TELLIGENT KEY SYSTEM)	21
COMMON ITEM : CONSULT-III Function (BCM -	7	BCM (BODY CONTROL SYSTEM) (WITHOUT	21
COMMON ITEM)	7	INTELLIGENT KEY SYSTEM) : Diagnosis Proce-	21
REAR WINDOW DEFOGGER	8	dure	21
REAR WINDOW DEFOGGER : CONSULT-III	8	IPDM E/R (WITH INTELLIGENT KEY SYSTEM)	22
Function (BCM - REAR DEFOGGER)	8	IPDM E/R (WITH INTELLIGENT KEY SYSTEM) :	22
DIAGNOSIS SYSTEM (BCM) (WITHOUT IN-	10	Diagnosis Procedure	22
TELLIGENT KEY SYSTEM)	10	IPDM E/R (WITHOUT INTELLIGENT KEY SYS-	23
COMMON ITEM	10	TEM)	23
COMMON ITEM : CONSULT-III Function (BCM -	10	IPDM E/R (WITHOUT INTELLIGENT KEY SYS-	23
COMMON ITEM)	10	TEM) : Diagnosis Procedure	23
REAR WINDOW DEFOGGER	11	REAR WINDOW DEFOGGER SWITCH	25
REAR WINDOW DEFOGGER : CONSULT-III	11	WITH AUTO A/C	25
Function (BCM - REAR DEFOGGER)	11	WITH AUTO A/C : Description	25
DIAGNOSIS SYSTEM (IPDM E/R)	13	WITH AUTO A/C : Component Function Check	25
WITH INTELLIGENT KEY	13	WITH AUTO A/C : Diagnosis Procedure	25
WITH INTELLIGENT KEY : Diagnosis Description	13	WITH AUTO A/C : Component Inspection	26
.....	13	WITHOUT AUTO A/C	26
WITH INTELLIGENT KEY : CONSULT-III Func-	15	WITHOUT AUTO A/C : Description	26
tion (IPDM E/R)	15	WITHOUT AUTO A/C : Component Function	26
		Check	26
		WITHOUT AUTO A/C : Diagnosis Procedure	26

WITHOUT AUTO A/C : Component Inspection	27	WITH INTELLIGENT KEY : Reference Value	44
WITHOUT A/C	28	WITH INTELLIGENT KEY : Wiring Diagram -	
WITHOUT A/C : Description	28	BCM -	65
WITHOUT A/C : Component Function Check	28	WITH INTELLIGENT KEY : Fail-safe	69
WITHOUT A/C : Diagnosis Procedure	28	WITH INTELLIGENT KEY :	
WITHOUT A/C : Component Inspection	29	DTC Inspection Priority Chart	71
		WITH INTELLIGENT KEY : DTC Index	73
REAR WINDOW DEFOGGER RELAY	30	WITHOUT INTELLIGENT KEY	75
Description	30	WITHOUT INTELLIGENT KEY : Reference Value...	75
Component Function Check	30	WITHOUT INTELLIGENT KEY : Wiring Diagram -	
Diagnosis Procedure	30	BCM -	91
		WITHOUT INTELLIGENT KEY : Fail-safe	94
		WITHOUT INTELLIGENT KEY : DTC Index	95
REAR WINDOW DEFOGGER	31	IPDM E/R (INTELLIGENT POWER DISTRI-	
Description	31	BUTION MODULE ENGINE ROOM)	97
Component Function Check	31	WITH INTELLIGENT KEY	97
Diagnosis Procedure	31	WITH INTELLIGENT KEY : Reference Value	97
Component Inspection	32	WITH INTELLIGENT KEY : Wiring Diagram —	
		IPDM E/R —	104
		WITH INTELLIGENT KEY : Fail-Safe	108
		WITH INTELLIGENT KEY : DTC Index	110
DOOR MIRROR DEFOGGER	34	WITHOUT INTELLIGENT KEY	110
Description	34	WITHOUT INTELLIGENT KEY : Reference Value.	110
Component Function Check	34	WITHOUT INTELLIGENT KEY : Wiring Diagram	
Diagnosis Procedure	34	— IPDM E/R —	117
		WITHOUT INTELLIGENT KEY : Fail-Safe	120
		WITHOUT INTELLIGENT KEY : DTC Index	122
DRIVER SIDE DOOR MIRROR DEFOGGER ...	35	SYMPTOM DIAGNOSIS	123
Description	35	REAR WINDOW DEFOGGER DOES NOT	
Component Function Check	35	OPERATE	123
Diagnosis Procedure	35	Diagnosis Procedure	123
		REAR WINDOW DEFOGGER AND DOOR	
		MIRROR DEFOGGER DO NOT OPERATE. ...	124
		Diagnosis Procedure	124
PASSENGER SIDE DOOR MIRROR DEFOG-		REAR WINDOW DEFOGGER DOES NOT	
GER	36	OPERATE BUT BOTH DOOR MIRROR DE-	
Description	36	FOGGERS OPERATE.	125
Component Function Check	36	Diagnosis Procedure	125
Diagnosis Procedure	36	DOOR MIRROR DEFOGGER DOES NOT OP-	
		ERATE	126
REAR WINDOW DEFOGGER ON SIGNAL	37	BOTH SIDES	126
WITH AUTO A/C	37	BOTH SIDES : Description	126
WITH AUTO A/C : Description	37	BOTH SIDES : Diagnosis Procedure	126
WITH AUTO A/C : Component Function Check	37	DRIVER SIDE	126
WITH AUTO A/C : Diagnosis Procedure	37	DRIVER SIDE : Description	126
		DRIVER SIDE : Diagnosis Procedure	126
WITHOUT AUTO A/C	37	PASSENGER SIDE	126
WITHOUT AUTO A/C : Description	37	PASSENGER SIDE : Description	126
WITHOUT AUTO A/C : Component Function		PASSENGER SIDE : Diagnosis Procedure	126
Check	37		
WITHOUT AUTO A/C : Diagnosis Procedure	37		
WITHOUT A/C	38		
WITHOUT A/C : Description	38		
WITHOUT A/C : Component Function Check	38		
WITHOUT A/C : Diagnosis Procedure	38		
REAR WINDOW DEFOGGER SYSTEM	39		
Wiring Diagram - DEFOGGER CONTROL SYS-			
TEM -	39		
ECU DIAGNOSIS INFORMATION	44		
BCM (BODY CONTROL MODULE)	44		
WITH INTELLIGENT KEY	44		

ON IS NOT DISPLAYED WHEN PRESSING REAR WINDOW DEFOGGER SWITCH BUT IT IS OPERATED	128
Diagnosis Procedure	128
PRECAUTION	129
PRECAUTIONS	129
Precaution for Supplemental Restraint System (SRS) "AIR BAG" and "SEAT BELT PRE-TENSIONER"	129

Precaution Necessary for Steering Wheel Rotation after Battery Disconnect	129
REMOVAL AND INSTALLATION	131
FILAMENT	131
Inspection and Repair	131
CONDENSER	133
Exploded View	133
Removal and Installation	133

A
B
C
D
E
F
G
H
I
J
K
DEF
M
N
O
P

DEF

DIAGNOSIS AND REPAIR WORK FLOW

< BASIC INSPECTION >

BASIC INSPECTION

DIAGNOSIS AND REPAIR WORK FLOW

Work Flow

INFOID:000000005049247

DETAILED FLOW

1.OBTAIN INFORMATION ABOUT SYMPTOM

Interview the customer to obtain the malfunction information (conditions and environment when the malfunction occurred) as much as possible when the customer brings the vehicle in.

>> GO TO 2.

2.CHECK FOR DTC

Perform self diagnosis with CONSULT-III

Is any DTC detected?

YES-1 >> BCM: Refer to [DEF-73. "WITH INTELLIGENT KEY : DTC Index"](#)(With intelligent Key system),[DEF-95. "WITHOUT INTELLIGENT KEY : DTC Index"](#) (Without intelligent Key system).

YES-2 >> IPDM E/R: Refer to [DEF-110. "WITH INTELLIGENT KEY : DTC Index"](#).(With intelligent Key system), [DEF-122. "WITHOUT INTELLIGENT KEY : DTC Index"](#)(Without intelligent Key system).

NO >> GO TO 3.

3.REPRODUCE THE MALFUNCTION INFORMATION

Check the malfunction on the vehicle that the customer describes.

Inspect the relation of the symptoms and the condition when the symptoms occur.

>> GO TO 4.

4.IDENTIFY THE MALFUNCTIONING SYSTEM WITH "SYMPTOM DIAGNOSIS"

Use "Symptom diagnosis" from the symptom inspection result in step 3. Then identify where to start performing the diagnosis based on possible causes and symptoms.

>> GO TO 5.

5.IDENTIFY MALFUNCTIONING PARTS WITH "COMPONENT DIAGNOSIS"

Perform the diagnosis with "Component diagnosis" of the applicable system.

>> GO TO 6.

6.REPAIR OR REPLACE THE MALFUNCTIONING PARTS

Repair or replace the specified malfunctioning parts.

>> GO TO 7.

7.FINAL CHECK

Check that malfunctions are not reproduced when obtaining the malfunction information from the customer, referring to the symptom inspection result in step 3.

Are all malfunctions corrected?

YES >> INSPECTION END

NO >> GO TO 4.

REAR WINDOW DEFOGGER SYSTEM

< SYSTEM DESCRIPTION >

SYSTEM DESCRIPTION

REAR WINDOW DEFOGGER SYSTEM

System Diagram

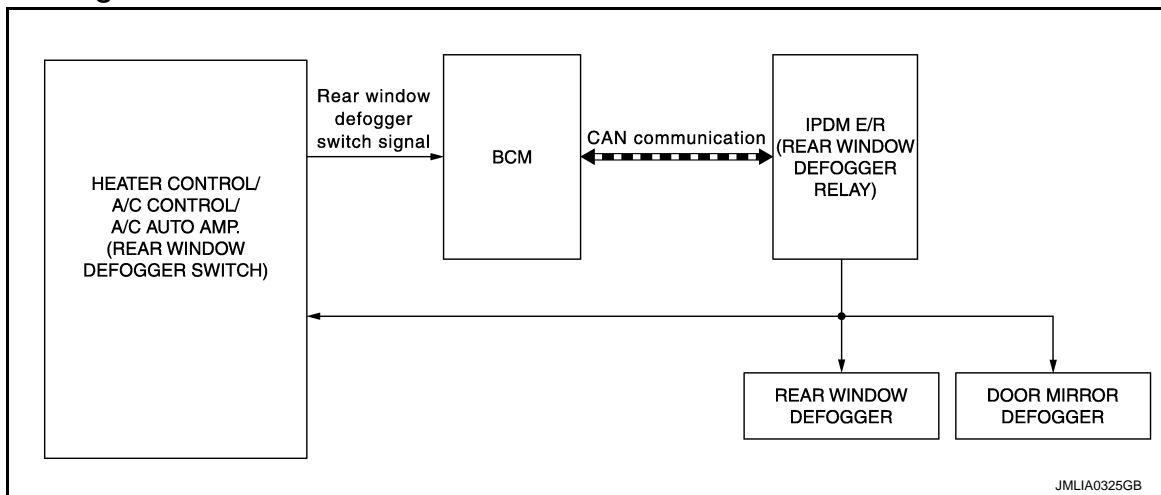

System Description

INFOID:000000005049249

OPERATION DESCRIPTION

- BCM detects that the rear window defogger switch turns ON when the ignition switch is ON, and then transmits the rear window defogger switch signal to IPDM E/R via CAN communication for approximately 15 minutes.
- IPDM E/R turns rear window defogger relay ON when it receives the rear window defogger switch signal.
- The power is supplied to the rear window defogger and door mirror defogger* when the rear window defogger relay turns ON.
- When rear window defogger is activated, indicator lamp on rear window defogger switch turns ON.

*: For cold areas

TIMER FUNCTION

- BCM transmits the rear window defogger switch signal to IPDM E/R for approximately 15 minutes when the rear window defogger switch is turned ON while ignition switch is ON. Then, IPDM E/R activates rear window defogger and door mirror defogger*.
- The timer is cancelled if the rear window defogger switch is pressed again during timer operation. BCM stops the output of rear window defogger switch signal. The same action occurs during timer operation if the ignition switch is OFF.

*: For cold areas

REAR WINDOW DEFOGGER SYSTEM

< SYSTEM DESCRIPTION >

Component Parts Location

INFOID:000000005049250

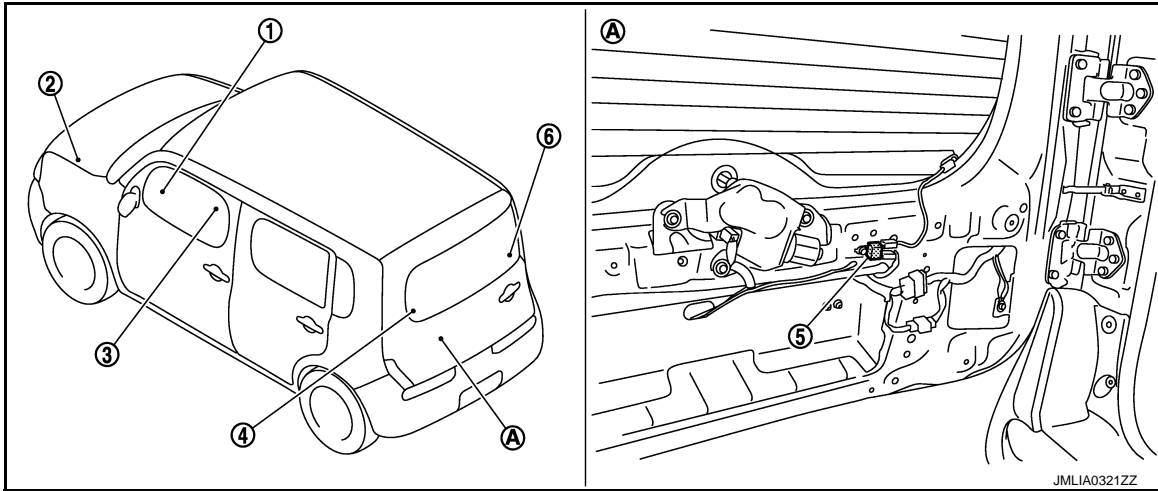

- | | | |
|--|---|---|
| <p>1. BCM</p> <ul style="list-style-type: none"> • With Intelligent Key system: M68, M70
Refer to BCS-9, "Component Parts Location" • Without Intelligent Key system: M65, M67
Refer to BCS-88, "Component Parts Location" | <p>2. IPDM E/R E11, E12, E13
Refer to PCS-6, "Component Parts Location"</p> | <p>3. • A/C auto amp.: M50, M51 (rear window defogger switch)
Refer to HAC-14, "Component Parts Location"</p> <ul style="list-style-type: none"> • A/C control: M53 (rear window defogger switch)
Refer to HAC-160, "Component Part Location" • Heater control: M28 (rear window defogger switch)
Refer to HAC-238, "Component Part Location" |
| <p>4. Rear window defogger connector D201</p> <p>A. Behind back door finisher lower</p> | <p>5. Condenser D103, D202</p> | <p>6. Rear window defogger connector D104</p> |

Component Description

INFOID:000000005049251

BCM	<ul style="list-style-type: none"> • Rear window defogger switch operation is transmitted to IPDM E/R via CAN communication • Performs the timer control of rear window defogger
Rear window defogger relay	Operates the rear window defogger with the control signal from IPDM E/R
IPDM E/R	BCM controls rear window defogger relay via CAN communication, and then operates rear window defogger
<ul style="list-style-type: none"> • A/C auto amp. (With AUTO A/C models) • A/C control (Without AUTO A/C models) • Heater control (Without A/C models) 	<ul style="list-style-type: none"> • The rear window defogger switch is installed • Turns the indicator lamp ON when detecting the operation of rear window defogger
Rear window defogger	Heats the heating wire with the power supply from the rear window defogger relay to prevent the rear window from fogging up
Door mirror defogger*	Heats the heating wire with the power supply from the rear window defogger relay to prevent the door mirror from fogging up

*: For cold areas

DIAGNOSIS SYSTEM (BCM) (WITH INTELLIGENT KEY SYSTEM)

< SYSTEM DESCRIPTION >

DIAGNOSIS SYSTEM (BCM) (WITH INTELLIGENT KEY SYSTEM) COMMON ITEM

COMMON ITEM : CONSULT-III Function (BCM - COMMON ITEM)

INFOID:000000005158219

APPLICATION ITEM

CONSULT-III performs the following functions via CAN communication with BCM.

Diagnosis mode	Function Description
Work Support	Changes the setting for each system function.
Self Diagnostic Result	Displays the diagnosis results judged by BCM.
CAN Diag Support Monitor	Monitors the reception status of CAN communication viewed from BCM. Refer to CONSULT-III operation manual.
Data Monitor	The BCM input/output signals are displayed.
Active Test	The signals used to activate each device are forcibly supplied from BCM.
Ecu Identification	The BCM part number is displayed.
Configuration	<ul style="list-style-type: none"> Read and save the vehicle specification. Write the vehicle specification when replacing BCM.

SYSTEM APPLICATION

BCM can perform the following functions for each system.

NOTE:

It can perform the diagnosis modes except the following for all sub system selection items.

x: Applicable item

System	Sub system selection item	Diagnosis mode		
		Work Support	Data Monitor	Active Test
Door lock	DOOR LOCK	x	x	x
Rear window defogger	REAR DEFOGGER		x	x
Warning chime	BUZZER		x	x
Interior room lamp timer	INT LAMP	x	x	x
Exterior lamp	HEAD LAMP	x	x	x
Wiper and washer	WIPER	x	x	x
Turn signal and hazard warning lamps	FLASHER	x	x	x
Automatic air conditioner	AIR CONDITONER		x	x
<ul style="list-style-type: none"> Intelligent Key system Engine start system 	INTELLIGENT KEY	x	x	x
Combination switch	COMB SW		x	
Body control system	BCM	x		
NVIS - NATS	IMMU	x	x	x
Interior room lamp battery saver	BATTERY SAVER	x	x	x
Back door	TRUNK		x	
Vehicle security system	THEFT ALM	x	x	x
RAP system	RETAINED PWR		x	
Signal buffer system	SIGNAL BUFFER		x	x
TPMS	TPMS (AIR PRESSURE MONITOR)	x	x	x

FREEZE FRAME DATA (FFD)

The BCM records the following vehicle condition at the time a particular DTC is detected, and displays on CONSULT-III.

DIAGNOSIS SYSTEM (BCM) (WITH INTELLIGENT KEY SYSTEM)

< SYSTEM DESCRIPTION >

CONSULT screen item	Indication/Unit	Description	
Vehicle Speed	km/h	Vehicle speed of the moment a particular DTC is detected	
Odo/Trip Meter	km	Total mileage (Odometer value) of the moment a particular DTC is detected	
Vehicle Condition	SLEEP>LOCK	Power position status of the moment a particular DTC is detected	While turning BCM status from low power consumption mode to normal mode (Power supply position is "LOCK")
	SLEEP>OFF		While turning BCM status from low power consumption mode to normal mode (Power supply position is "OFF".)
	LOCK>ACC		While turning power supply position from "LOCK" to "ACC"
	ACC>ON		While turning power supply position from "ACC" to "IGN"
	RUN>ACC		While turning power supply position from "RUN" to "ACC" (Vehicle is stopping and selector lever is except P position.)
	CRANK>RUN		While turning power supply position from "CRANKING" to "RUN" (From cranking up the engine to run it)
	RUN>URGENT		While turning power supply position from "RUN" to "ACC" (Emergency stop operation)
	ACC>OFF		While turning power supply position from "ACC" to "OFF"
	OFF>LOCK		While turning power supply position from "OFF" to "LOCK"
	OFF>ACC		While turning power supply position from "OFF" to "ACC"
	ON>CRANK		While turning power supply position from "IGN" to "CRANKING"
	OFF>SLEEP		While turning BCM status from normal mode (Power supply position is "OFF".) to low power consumption mode
	LOCK>SLEEP		While turning BCM status from normal mode (Power supply position is "LOCK".) to low power consumption mode
	LOCK		Power supply position is "LOCK" (Ignition switch OFF with steering is locked.)
	OFF		Power supply position is "OFF" (Ignition switch OFF with steering is unlocked.)
	ACC		Power supply position is "ACC" (Ignition switch ACC)
	ON		Power supply position is "IGN" (Ignition switch ON with engine stopped)
ENGINE RUN	Power supply position is "RUN" (Ignition switch ON with engine running)		
CRANKING	Power supply position is "CRANKING" (At engine cranking)		
IGN Counter	0 - 39	<p>The number of times that ignition switch is turned ON after DTC is detected</p> <ul style="list-style-type: none"> • The number is 0 when a malfunction is detected now. • The number increases like 1 → 2 → 3...38 → 39 after returning to the normal condition whenever ignition switch OFF → ON. • The number is fixed to 39 until the self-diagnosis results are erased if it is over 39. 	

REAR WINDOW DEFOGGER

REAR WINDOW DEFOGGER : CONSULT-III Function (BCM - REAR DEFOGGER)

INFOID:000000005049253

DATA MONITOR

Monitor Item	Description
PUSH SW	Indicates [ON/OFF] condition of push switch.
REAR DEF SW	This is displayed even when it is not equipped.

ACTIVE TEST

DIAGNOSIS SYSTEM (BCM) (WITH INTELLIGENT KEY SYSTEM)

< SYSTEM DESCRIPTION >

Test Item	Description
REAR DEFOGGER	This test is able to check rear window defogger operation. Rear window defogger operates when "ON" on CONSULT-III screen is touched.

A

B

C

D

E

F

G

H

I

J

K

DEF

M

N

O

P

DIAGNOSIS SYSTEM (BCM) (WITHOUT INTELLIGENT KEY SYSTEM)

< SYSTEM DESCRIPTION >

DIAGNOSIS SYSTEM (BCM) (WITHOUT INTELLIGENT KEY SYSTEM) COMMON ITEM

COMMON ITEM : CONSULT-III Function (BCM - COMMON ITEM)

INFOID:000000005158218

APPLICATION ITEM

CONSULT-III performs the following functions via CAN communication with BCM.

Diagnosis mode	Function Description
Work Support	Changes the setting for each system function.
Self Diagnostic Result	Displays the diagnosis results judged by BCM.
CAN Diag Support Monitor	Monitors the reception status of CAN communication viewed from BCM. Refer to CONSULT-III operation manual.
Data Monitor	The BCM input/output signals are displayed.
Active Test	The signals used to activate each device are forcibly supplied from BCM.
Ecu Identification	The BCM part number is displayed.
Configuration	<ul style="list-style-type: none"> Read and save the vehicle specification. Write the vehicle specification when replacing BCM.

SYSTEM APPLICATION

BCM can perform the following functions for each system.

NOTE:

It can perform the diagnosis modes except the following for all sub system selection items.

×: Applicable item

System	Sub system selection item	Diagnosis mode		
		Work Support	Data Monitor	Active Test
Door lock	DOOR LOCK	×	×	×
Rear window defogger	REAR DEFOGGER		×	×
Warning chime	BUZZER		×	×
Interior room lamp timer	INT LAMP	×	×	×
Exterior lamp	HEAD LAMP	×	×	×
Wiper and washer	WIPER	×	×	×
Turn signal and hazard warning lamps	FLASHER	×	×	×
Automatic air conditioner	AIR CONDITONER		×	×
<ul style="list-style-type: none"> Intelligent Key system Engine start system 	INTELLIGENT KEY	×	×	×
Combination switch	COMB SW		×	
Body control system	BCM	×		
NVIS - NATS	IMMU	×	×	×
Interior room lamp battery saver	BATTERY SAVER	×	×	×
Back door	TRUNK		×	
Vehicle security system	THEFT ALM	×	×	×
RAP system	RETAINED PWR		×	
Signal buffer system	SIGNAL BUFFER		×	×
TPMS	TPMS (AIR PRESSURE MONITOR)	×	×	×

FREEZE FRAME DATA (FFD)

The BCM records the following vehicle condition at the time a particular DTC is detected, and displays on CONSULT-III.

DIAGNOSIS SYSTEM (BCM) (WITHOUT INTELLIGENT KEY SYSTEM)

< SYSTEM DESCRIPTION >

CONSULT screen item	Indication/Unit	Description		
Vehicle Speed	km/h	Vehicle speed of the moment a particular DTC is detected		A
Odo/Trip Meter	km	Total mileage (Odometer value) of the moment a particular DTC is detected		B
Vehicle Condition	SLEEP>LOCK	Power position status of the moment a particular DTC is detected	While turning BCM status from low power consumption mode to normal mode (Power supply position is "LOCK")	C
	SLEEP>OFF		While turning BCM status from low power consumption mode to normal mode (Power supply position is "OFF".)	D
	LOCK>ACC		While turning power supply position from "LOCK" to "ACC"	E
	ACC>ON		While turning power supply position from "ACC" to "IGN"	F
	RUN>ACC		While turning power supply position from "RUN" to "ACC" (Vehicle is stopping and selector lever is except P position.)	G
	CRANK>RUN		While turning power supply position from "CRANKING" to "RUN" (From cranking up the engine to run it)	H
	RUN>URGENT		While turning power supply position from "RUN" to "ACC" (Emergency stop operation)	I
	ACC>OFF		While turning power supply position from "ACC" to "OFF"	J
	OFF>LOCK		While turning power supply position from "OFF" to "LOCK"	K
	OFF>ACC		While turning power supply position from "OFF" to "ACC"	DEF
	ON>CRANK		While turning power supply position from "IGN" to "CRANKING"	
	OFF>SLEEP		While turning BCM status from normal mode (Power supply position is "OFF".) to low power consumption mode	
	LOCK>SLEEP		While turning BCM status from normal mode (Power supply position is "LOCK".) to low power consumption mode	
	LOCK		Power supply position is "LOCK" (Ignition switch OFF with steering is locked.)	
	OFF		Power supply position is "OFF" (Ignition switch OFF with steering is unlocked.)	
	ACC		Power supply position is "ACC" (Ignition switch ACC)	
ON	Power supply position is "IGN" (Ignition switch ON with engine stopped)			
ENGINE RUN	Power supply position is "RUN" (Ignition switch ON with engine running)			
CRANKING	Power supply position is "CRANKING" (At engine cranking)			
IGN Counter	0 - 39	The number of times that ignition switch is turned ON after DTC is detected <ul style="list-style-type: none"> • The number is 0 when a malfunction is detected now. • The number increases like 1 → 2 → 3...38 → 39 after returning to the normal condition whenever ignition switch OFF → ON. • The number is fixed to 39 until the self-diagnosis results are erased if it is over 39. 		M

REAR WINDOW DEFOGGER

REAR WINDOW DEFOGGER : CONSULT-III Function (BCM - REAR DEFOGGER)

INFOID:000000005049333

DATA MONITOR

Monitor Item	Description
IGN ON SW	Indicates [ON/OFF] condition of ignition switch in ON position.
ACC ON SW	Indicates [ON/OFF] condition of ignition switch in ACC position.
REAR DEF SW	Displays "Press (ON)/other (OFF)" status determined with the rear window defogger switch.

ACTIVE TEST

DIAGNOSIS SYSTEM (BCM) (WITHOUT INTELLIGENT KEY SYSTEM)

< SYSTEM DESCRIPTION >

Test Item	Description
REAR DEFOGGER	This test is able to check rear window defogger operation. Rear window defogger operates when "ON" on CONSULT-III screen is touched.

DIAGNOSIS SYSTEM (IPDM E/R)

< SYSTEM DESCRIPTION >

DIAGNOSIS SYSTEM (IPDM E/R) WITH INTELLIGENT KEY

WITH INTELLIGENT KEY : Diagnosis Description

INFOID:000000005158329

AUTO ACTIVE TEST

Description

In auto active test mode, the IPDM E/R sends a drive signal to the following systems to check their operation.

- Oil pressure warning lamp
- Rear window defogger
- Front wiper (LO, HI)
- Parking lamps
- Side marker lamp
- License plate lamps
- Tail lamps
- Front fog lamps
- Headlamps (LO, HI)
- A/C compressor (magnet clutch)
- Cooling fan

Operation Procedure

1. Close the hood and lift the wiper arms from the windshield. (Prevent windshield damage due to wiper operation)

NOTE:

When auto active test is performed with hood opened, sprinkle water on windshield beforehand.

2. Turn the ignition switch OFF.
3. Turn the ignition switch ON, and within 20 seconds, press the driver door switch 10 times. Then turn the ignition switch OFF.

CAUTION:

Close passenger door.

4. Turn the ignition switch ON within 10 seconds. After that the horn sounds once and the auto active test starts.
5. The oil pressure warning lamp starts blinking when the auto active test starts.
6. After a series of the following operations is repeated 3 times, auto active test is completed.

NOTE:

When auto active test mode has to be cancelled halfway through test, turn the ignition switch OFF.

CAUTION:

- If auto active test mode cannot be actuated, check door switch system. Refer to [DLK-55, "Component Function Check"](#).
- Do not start the engine.

Inspection in Auto Active Test Mode

When auto active test mode is actuated, the following 6 steps are repeated 3 times.

Operation sequence	Inspection location	Operation
A	Oil pressure warning lamp	Blinks continuously during operation of auto active test
1	Rear window defogger	10 seconds
2	Front wiper	LO for 5 seconds → HI for 5 seconds
3	<ul style="list-style-type: none"> • Parking lamps • Side marker lamps • License plate lamps • Tail lamps • Front fog lamps 	10 seconds
4	Headlamps	LO for 10 seconds → HI ON ↔ OFF 5 times

DIAGNOSIS SYSTEM (IPDM E/R)

< SYSTEM DESCRIPTION >

Operation sequence	Inspection location	Operation
5	A/C compressor (magnet clutch)	ON ⇔ OFF 5 times
6	Cooling fan	LO for 5 seconds → HI for 5 seconds

Concept of auto active test

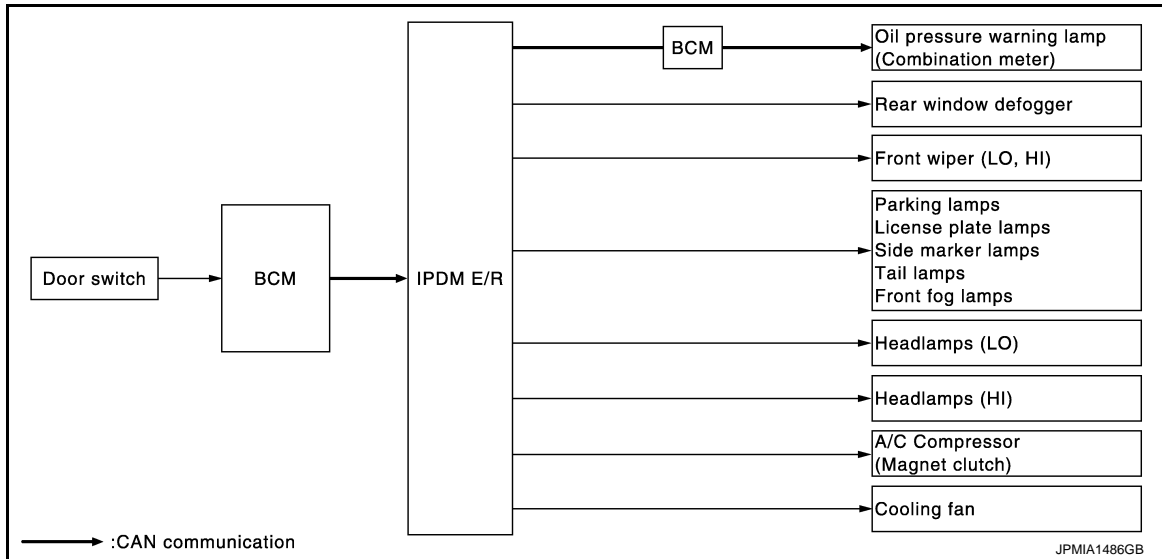

- IPDM E/R starts the auto active test with the door switch signals transmitted by BCM via CAN communication. Therefore, the CAN communication line between IPDM E/R and BCM is considered normal if the auto active test starts successfully.
- The auto active test facilitates troubleshooting if any systems controlled by IPDM E/R cannot be operated.

Diagnosis chart in auto active test mode

Symptom	Inspection contents	Possible cause
Rear window defogger does not operate	Perform auto active test. Does the rear window defogger operate?	YES BCM signal input circuit
		NO <ul style="list-style-type: none"> • Rear window defogger • Rear window defogger ground circuit • Harness or connector between IPDM E/R and rear window defogger • IPDM E/R
Any of the following components do not operate <ul style="list-style-type: none"> • Parking lamps • Side marker lamps • License plate lamps • Tail lamps • Front fog lamps • Headlamps (HI, LO) • Front wiper (HI, LO) 	Perform auto active test. Does the applicable system operate?	YES BCM signal input circuit
		NO <ul style="list-style-type: none"> • Lamp or motor • Lamp or motor ground circuit • Harness or connector between IPDM E/R and applicable system • IPDM E/R
A/C compressor does not operate	Perform auto active test. Does the magnet clutch operate?	YES <ul style="list-style-type: none"> • A/C amp. signal input circuit • CAN communication signal between A/C amp. and ECM • CAN communication signal between ECM and IPDM E/R
		NO <ul style="list-style-type: none"> • Magnet clutch • Harness or connector between IPDM E/R and magnet clutch • IPDM E/R

DIAGNOSIS SYSTEM (IPDM E/R)

< SYSTEM DESCRIPTION >

Symptom	Inspection contents		Possible cause
Oil pressure warning lamp does not operate	Perform auto active test. Does the oil pressure warning lamp blink?	YES	<ul style="list-style-type: none"> • Harness or connector between IPDM E/R and oil pressure switch • Oil pressure switch • IPDM E/R
		NO	<ul style="list-style-type: none"> • CAN communication signal between IPDM E/R and BCM • CAN communication signal between BCM and combination meter • Combination meter
Cooling fan does not operate	Perform auto active test. Does the cooling fan operate?	YES	<ul style="list-style-type: none"> • ECM signal input circuit • CAN communication signal between ECM and IPDM E/R
		NO	<ul style="list-style-type: none"> • Cooling fan motor • Harness or connector between IPDM E/R and cooling fan motor • IPDM E/R

WITH INTELLIGENT KEY : CONSULT-III Function (IPDM E/R)

INFOID:000000005158330

APPLICATION ITEM

CONSULT-III performs the following functions via CAN communication with IPDM E/R.

Diagnosis mode	Description
Ecu Identification	Allows confirmation of IPDM E/R part number.
Self Diagnostic Result	Displays the diagnosis results judged by IPDM E/R.
Data Monitor	Displays the real-time input/output data from IPDM E/R input/output data.
Active Test	IPDM E/R can provide a drive signal to electronic components to check their operations.
CAN Diag Support Monitor	The results of transmit/receive diagnosis of CAN communication can be read.

SELF DIAGNOSTIC RESULT

Refer to [PCS-33, "DTC Index"](#).

DATA MONITOR

Monitor item

Monitor Item [Unit]	MAIN SIGNALS	Description
MOTOR FAN REQ [1/2/3/4]	×	Displays the value of the cooling fan speed request signal received from ECM via CAN communication.
AC COMP REQ [Off/On]	×	Displays the status of the A/C compressor request signal received from ECM via CAN communication.
TAIL&CLR REQ [Off/On]	×	Displays the status of the position light request signal received from BCM via CAN communication.
HL LO REQ [Off/On]	×	Displays the status of the low beam request signal received from BCM via CAN communication.
HL HI REQ [Off/On]	×	Displays the status of the high beam request signal received from BCM via CAN communication.
FR FOG REQ [Off/On]	×	Displays the status of the front fog light request signal received from BCM via CAN communication.
FR WIP REQ [Stop/1LOW/Low/Hi]	×	Displays the status of the front wiper request signal received from BCM via CAN communication.

DIAGNOSIS SYSTEM (IPDM E/R)

< SYSTEM DESCRIPTION >

Monitor Item [Unit]	MAIN SIG- NALS	Description
WIP AUTO STOP [STOP P/ACT P]	×	Displays the status of the front wiper auto stop signal judged by IPDM E/R.
WIP PROT [Off/BLOCK]	×	Displays the status of the front wiper fail-safe operation judged by IPDM E/R.
IGN RLY1 -REQ [Off/On]		Displays the status of the ignition switch ON signal received from BCM via CAN communication.
IGN RLY [Off/On]	×	Displays the status of the ignition relay judged by IPDM E/R.
PUSH SW [Off/On]		Displays the status of the push-button ignition switch judged by IPDM E/R.
INTER/NP SW [Off/On]		Displays the status of the clutch interlock switch (M/T models) or shift position (CVT models) judged by IPDM E/R.
ST RLY CONT [Off/On]		Displays the status of the starter relay status signal received from BCM via CAN communication.
IHBT RLY -REQ [Off/On]		Displays the status of the starter control relay signal received from BCM via CAN communication.
ST/INHI RLY [Off/ ST ON/INHI ON/UNKWN]		Displays the status of the starter relay and starter control relay judged by IPDM E/R.
DETENT SW [Off/On]		Displays the status of the CVT shift selector (detention switch) judged by IPDM E/R.
S/L RLY -REQ [Off/On]		Displays the status of the steering lock relay signal received from BCM via CAN communication.
S/L STATE [LOCK/UNLOCK/UNKWN]		Displays the status of the steering lock judged by IPDM E/R.
DTRL REQ [Off/On]		Displays the status of the daytime running light request signal received from BCM via CAN communication. NOTE: This item is monitored only the vehicle with daytime running light system.
OIL P SW [Open/Close]		Displays the status of the oil pressure switch judged by IPDM E/R.
HOOD SW [Off/On]		NOTE: The item is indicated, but not monitored.
THFT HRN REQ [Off/On]		Displays the status of the theft warning horn request signal received from BCM via CAN communication.
HORN CHIRP [Off/On]		Displays the status of the horn reminder signal received from BCM via CAN communication.

ACTIVE TEST

Test item

Test item	Operation	Description
HORN	On	Operates horn relay for 20 ms.
FRONT WIPER	Off	OFF
	Lo	Operates the front wiper relay.
	Hi	Operates the front wiper relay and front wiper high relay.
MOTOR FAN	1	OFF
	2	Operates the cooling fan relay (LO operation).
	3	Operates the cooling fan relay (HI operation).
	4	

DIAGNOSIS SYSTEM (IPDM E/R)

< SYSTEM DESCRIPTION >

Test item	Operation	Description
EXTERNAL LAMPS	Off	OFF
	TAIL	Operates the tail lamp relay.
	Lo	Operates the headlamp low relay.
	Hi	Operates the headlamp low relay and ON/OFF the headlamp high relay at 1 second intervals.
	Fog	Operates the front fog lamp relay.

WITHOUT INTELLIGENT KEY

WITHOUT INTELLIGENT KEY : Diagnosis Description

INFOID:000000005190389

AUTO ACTIVE TEST

Description

In auto active test mode, the IPDM E/R sends a drive signal to the following systems to check their operation.

- Oil pressure warning lamp
- Rear window defogger
- Front wiper (LO, HI)
- Parking lamps
- Side marker lamp
- License plate lamps
- Tail lamps
- Front fog lamps
- Headlamps (LO, HI)
- A/C compressor (magnet clutch)
- Cooling fan

Operation Procedure

1. Close the hood and lift the wiper arms from the windshield. (Prevent windshield damage due to wiper operation)
NOTE:
 When auto active test is performed with hood opened, sprinkle water on windshield beforehand.
2. Turn the ignition switch OFF.
3. Turn the ignition switch ON, and within 20 seconds, press the driver door switch 10 times. Then turn the ignition switch OFF.
CAUTION:
Close passenger door.
4. Turn the ignition switch ON within 10 seconds. After that the horn sounds once and the auto active test starts.
5. The oil pressure warning lamp starts blinking when the auto active test starts.
6. After a series of the following operations is repeated 3 times, auto active test is completed.

NOTE:

When auto active test mode has to be cancelled halfway through test, turn the ignition switch OFF.

CAUTION:

- If auto active test mode cannot be actuated, check door switch system. Refer to [DLK-55, "Component Function Check"](#).
- Do not start the engine.

Inspection in Auto Active Test Mode

When auto active test mode is actuated, the following 6 steps are repeated 3 times.

Operation sequence	Inspection location	Operation
A	Oil pressure warning lamp	Blinks continuously during operation of auto active test
1	Rear window defogger	10 seconds
2	Front wiper	LO for 5 seconds → HI for 5 seconds

DIAGNOSIS SYSTEM (IPDM E/R)

< SYSTEM DESCRIPTION >

Operation sequence	Inspection location	Operation
3	<ul style="list-style-type: none"> • Parking lamps • Side marker lamps • License plate lamps • Tail lamps • Front fog lamps 	10 seconds
4	Headlamps	LO for 10 seconds → HI ON ↔ OFF 5 times
5	A/C compressor (magnet clutch)	ON ↔ OFF 5 times
6	Cooling fan	LO for 5 seconds → HI for 5 seconds

Concept of auto active test

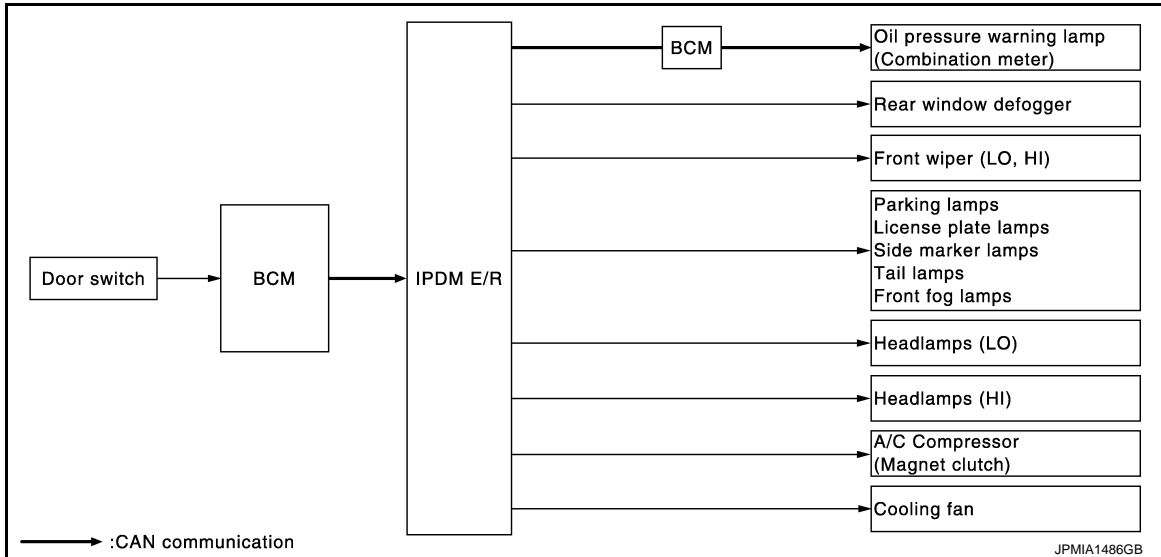

- IPDM E/R starts the auto active test with the door switch signals transmitted by BCM via CAN communication. Therefore, the CAN communication line between IPDM E/R and BCM is considered normal if the auto active test starts successfully.
- The auto active test facilitates troubleshooting if any systems controlled by IPDM E/R cannot be operated.

Diagnosis chart in auto active test mode

Symptom	Inspection contents	Possible cause
Rear window defogger does not operate	Perform auto active test. Does the rear window defogger operate?	YES BCM signal input circuit
		NO <ul style="list-style-type: none"> • Rear window defogger • Rear window defogger ground circuit • Harness or connector between IPDM E/R and rear window defogger • IPDM E/R
Any of the following components do not operate <ul style="list-style-type: none"> • Parking lamps • Side marker lamps • License plate lamps • Tail lamps • Front fog lamps • Headlamps (HI, LO) • Front wiper (HI, LO) 	Perform auto active test. Does the applicable system operate?	YES BCM signal input circuit
		NO <ul style="list-style-type: none"> • Lamp or motor • Lamp or motor ground circuit • Harness or connector between IPDM E/R and applicable system • IPDM E/R

DIAGNOSIS SYSTEM (IPDM E/R)

< SYSTEM DESCRIPTION >

Symptom	Inspection contents	Possible cause
A/C compressor does not operate	Perform auto active test. Does the magnet clutch operate?	YES <ul style="list-style-type: none"> • A/C amp. signal input circuit • CAN communication signal between A/C amp. and ECM • CAN communication signal between ECM and IPDM E/R
		NO <ul style="list-style-type: none"> • Magnet clutch • Harness or connector between IPDM E/R and magnet clutch • IPDM E/R
Oil pressure warning lamp does not operate	Perform auto active test. Does the oil pressure warning lamp blink?	YES <ul style="list-style-type: none"> • Harness or connector between IPDM E/R and oil pressure switch • Oil pressure switch • IPDM E/R
		NO <ul style="list-style-type: none"> • CAN communication signal between IPDM E/R and BCM • CAN communication signal between BCM and combination meter • Combination meter
Cooling fan does not operate	Perform auto active test. Does the cooling fan operate?	YES <ul style="list-style-type: none"> • ECM signal input circuit • CAN communication signal between ECM and IPDM E/R
		NO <ul style="list-style-type: none"> • Cooling fan motor • Harness or connector between IPDM E/R and cooling fan motor • IPDM E/R

WITHOUT INTELLIGENT KEY : CONSULT-III Function (IPDM E/R)

INFOID:000000005190390

APPLICATION ITEM

CONSULT-III performs the following functions via CAN communication with IPDM E/R.

Diagnosis mode	Description
Ecu Identification	Allows confirmation of IPDM E/R part number.
Self Diagnostic Result	Displays the diagnosis results judged by IPDM E/R.
Data Monitor	Displays the real-time input/output data from IPDM E/R input/output data.
Active Test	IPDM E/R can provide a drive signal to electronic components to check their operations.
CAN Diag Support Monitor	The results of transmit/receive diagnosis of CAN communication can be read.

SELF DIAGNOSTIC RESULT

Refer to [PCS-63, "DTC Index"](#).

DATA MONITOR

Monitor item

Monitor Item [Unit]	MAIN SIGNALS	Description
MOTOR FAN REQ [1/2/3/4]	×	Displays the value of the cooling fan speed request signal received from ECM via CAN communication.
AC COMP REQ [Off/On]	×	Displays the status of the A/C compressor request signal received from ECM via CAN communication.

DIAGNOSIS SYSTEM (IPDM E/R)

< SYSTEM DESCRIPTION >

Monitor Item [Unit]	MAIN SIG- NALS	Description
TAIL&CLR REQ [Off/On]	×	Displays the status of the position light request signal received from BCM via CAN communication.
HL LO REQ [Off/On]	×	Displays the status of the low beam request signal received from BCM via CAN communication.
HL HI REQ [Off/On]	×	Displays the status of the high beam request signal received from BCM via CAN communication.
FR FOG REQ [Off/On]	×	Displays the status of the front fog light request signal received from BCM via CAN communication.
FR WIP REQ [Stop/1LOW/Low/Hi]	×	Displays the status of the front wiper request signal received from BCM via CAN communication.
WIP AUTO STOP [STOP P/ACT P]	×	Displays the status of the front wiper auto stop signal judged by IPDM E/R.
WIP PROT [Off/BLOCK]	×	Displays the status of the front wiper fail-safe operation judged by IPDM E/R.
IGN RLY [Off/On]	×	Displays the status of the ignition relay judged by IPDM E/R.
INTER/NP SW [Off/On]		Displays the status of the shift position (CVT models) judged by IPDM E/R.
ST RLY-REQ [Off/On]		Displays the status of the starter relay status signal received from BCM via CAN communication.
DTRL REQ [Off/On]		Displays the status of the daytime running light request signal received from BCM via CAN communication. NOTE: This item is monitored only the vehicle with daytime running light system.
OIL P SW [Open/Close]		Displays the status of the oil pressure switch judged by IPDM E/R.
HOOD SW [Off/On]		NOTE: The item is indicated, but not monitored.
THFT HRN REQ [Off/On]		Displays the status of the theft warning horn request signal received from BCM via CAN communication.
HORN CHIRP [Off/On]		Displays the status of the horn reminder signal received from BCM via CAN communication.

ACTIVE TEST

Test item

Test item	Operation	Description
HORN	On	Operates horn relay for 20 ms.
	Off	OFF
FRONT WIPER	Lo	Operates the front wiper relay.
	Hi	Operates the front wiper relay and front wiper high relay.
MOTOR FAN	1	OFF
	2	Operates the cooling fan relay (LO operation).
	3	Operates the cooling fan relay (HI operation).
	4	
EXTERNAL LAMPS	Off	OFF
	TAIL	Operates the tail lamp relay.
	Lo	Operates the headlamp low relay.
	Hi	Operates the headlamp low relay and ON/OFF the headlamp high relay at 1 second intervals.
	Fog	Operates the front fog lamp relay.

POWER SUPPLY AND GROUND CIRCUIT

< DTC/CIRCUIT DIAGNOSIS >

DTC/CIRCUIT DIAGNOSIS

POWER SUPPLY AND GROUND CIRCUIT

BCM (BODY CONTROL SYSTEM) (WITH INTELLIGENT KEY SYSTEM)

BCM (BODY CONTROL SYSTEM) (WITH INTELLIGENT KEY SYSTEM) : Diagnosis Procedure

INFOID:000000005158214

1. CHECK FUSE AND FUSIBLE LINK

Check that the following fuse and fusible link are not blown.

Signal name	Fuse and fusible link No.
Battery power supply	G
	8

Is the fuse fusing?

YES >> Replace the blown fuse or fusible link after repairing the affected circuit if a fuse or fusible link is blown.

NO >> GO TO 2.

2. CHECK POWER SUPPLY CIRCUIT

1. Turn ignition switch OFF.
2. Disconnect BCM connectors.
3. Check voltage between BCM harness connector and ground.

Terminals		Voltage (Approx.)
(+)	(-)	
BCM		Ground Battery voltage
Connector	Terminal	
M70	70	
	57	

Is the measurement value normal?

YES >> GO TO 3.

NO >> Repair harness or connector.

3. CHECK GROUND CIRCUIT

Check continuity between BCM harness connector and ground.

BCM		Ground	Continuity
Connector	Terminal		
M70	67		Existed

Does continuity exist?

YES >> INSPECTION END

NO >> Repair harness or connector.

BCM (BODY CONTROL SYSTEM) (WITHOUT INTELLIGENT KEY SYSTEM)

BCM (BODY CONTROL SYSTEM) (WITHOUT INTELLIGENT KEY SYSTEM) : Diagnosis Procedure

INFOID:000000005158215

1. CHECK FUSES AND FUSIBLE LINK

Check that the following fuses and fusible link are not fusing.

POWER SUPPLY AND GROUND CIRCUIT

< DTC/CIRCUIT DIAGNOSIS >

Signal name	Fuses and fusible link No.
Battery power supply	8
	G
ACC power supply	20
Ignition power supply	2

Is the fuse fusing?

YES >> Replace the blown fuse or fusible link after repairing the affected circuit if a fuse or fusible link is blown.

NO >> GO TO 2.

2.CHECK POWER SUPPLY CIRCUIT

1. Turn ignition switch OFF.
2. Disconnect BCM connectors.
3. Check voltage between BCM harness connector and ground.

Terminals		(-)	Ignition switch position		
BCM			OFF	ACC	ON
Connector	Terminal				
M67	70	Ground	Battery voltage	Battery voltage	Battery voltage
	57		Battery voltage	Battery voltage	Battery voltage
M65	11		Approx. 0 V	Battery voltage	Battery voltage
	38		Approx. 0 V	Approx. 0 V	Battery voltage

Is the measurement value normal?

YES >> GO TO 3.

NO >> Repair harness or connector.

3.CHECK GROUND CIRCUIT

Check continuity between BCM harness connector and ground.

BCM		Ground	Continuity
Connector	Terminal		
M67	67		Existed

Does continuity exist?

YES >> INSPECTION END

NO >> Repair harness or connector.

IPDM E/R (WITH INTELLIGENT KEY SYSTEM)

IPDM E/R (WITH INTELLIGENT KEY SYSTEM) : Diagnosis Procedure

INFOID:000000005158216

1.CHECK FUSES AND FUSIBLE LINK

Check that the following IPDM E/R fuses or fusible links are not blown.

Signal name	Fuses and fusible link No.
Battery power supply	C
	D
	J

Is the fuse fusing?

POWER SUPPLY AND GROUND CIRCUIT

< DTC/CIRCUIT DIAGNOSIS >

- YES >> Replace the blown fuse or fusible link after repairing the affected circuit if a fuse or fusible link is blown.
- NO >> GO TO 2.

2.CHECK POWER SUPPLY CIRCUIT

1. Turn the ignition switch OFF.
2. Disconnect IPDM E/R connector.
3. Check voltage between IPDM E/R harness connector and the ground.

Terminals		Voltage (Approx.)
(+)	(-)	
IPDM E/R		Battery voltage
Connector	Terminal	
E9	1	
	2	
E10	8	

Is the measurement value normal?

- YES >> GO TO 3.
- NO >> Repair the harness or connector.

3.CHECK GROUND CIRCUIT

Check continuity between IPDM E/R harness connectors and the ground.

IPDM E/R		Ground	Continuity
Connector	Terminal		
E11	9		Existed
E12	19		

Does continuity exist?

- YES >> INSPECTION END
- NO >> Repair the harness or connector.

IPDM E/R (WITHOUT INTELLIGENT KEY SYSTEM)

IPDM E/R (WITHOUT INTELLIGENT KEY SYSTEM) : Diagnosis Procedure

INFOID:000000005158217

DEF

1.CHECK FUSES AND FUSIBLE LINK

Check that the following IPDM E/R fuses or fusible links are not blown.

Signal name	Fuses and fusible link No.
Battery power supply	C
	D
	J

Is the fuse fusing?

- YES >> Replace the blown fuse or fusible link after repairing the affected circuit if a fuse or fusible link is blown.
- NO >> GO TO 2.

2.CHECK POWER SUPPLY CIRCUIT

1. Turn the ignition switch OFF.
2. Disconnect IPDM E/R connector.
3. Check voltage between IPDM E/R harness connector and the ground.

POWER SUPPLY AND GROUND CIRCUIT

< DTC/CIRCUIT DIAGNOSIS >

Terminals		(-)	Voltage (Approx.)
(+) IPDM E/R			
Connector	Terminal	Ground	Battery voltage
E9	1		
	2		
E10	8		

Is the measurement value normal?

YES >> GO TO 3.

NO >> Repair the harness or connector.

3. CHECK IGNITION POWER SUPPLY CIRCUIT

1. Turn the ignition switch ON.
2. Check voltage between IPDM E/R harness connector and the ground.

Terminals		(-)	Voltage (Approx.)
(+) IPDM E/R			
Connector	Terminal	Ground	Battery voltage
E12	18		

Is the measurement value normal?

YES >> GO TO 4.

NO >> Repair the harness or connector.

4. CHECK GROUND CIRCUIT

1. Turn the ignition switch OFF.
2. Check continuity between IPDM E/R harness connectors and the ground.

IPDM E/R		Ground	Continuity
Connector	Terminal		Existed
E11	9		Existed
E12	19		

Does continuity exist?

YES >> INSPECTION END

NO >> Repair the harness or connector.

REAR WINDOW DEFOGGER SWITCH

< DTC/CIRCUIT DIAGNOSIS >

REAR WINDOW DEFOGGER SWITCH WITH AUTO A/C

WITH AUTO A/C : Description

INFOID:000000005071704

- The rear window defogger is operated by turning the rear window defogger switch ON.
- The indicator lamp in the rear window defogger illuminates when the rear window defogger is operating.

WITH AUTO A/C : Component Function Check

INFOID:000000005071700

1. CHECK FUNCTION

Check (REAR DEF SW) in BCM "DATA MONITOR" mode using CONSULT-III when rear window defogger switch is ON.

Is the inspection result normal?

- YES >> Rear window defogger switch function is OK.
 NO >> Refer to [DEF-25, "WITH AUTO A/C : Diagnosis Procedure"](#)

WITH AUTO A/C : Diagnosis Procedure

INFOID:000000005049258

1. CHECK BCM OUTPUT SIGNAL

1. Turn ignition switch OFF.
2. Disconnect A/C auto amp. connector.
3. Check signal between A/C auto amp. harness connector and ground using oscilloscope.

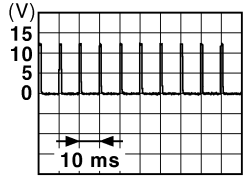
(+)		(-)	Voltage (V) (Approx.)
A/C auto amp.			
Connector	Terminal		
M51	33	Ground	 <p style="text-align: right;">JPMA0012GB</p>

Is the inspection result normal?

- YES >> GO TO 3.
 NO >> GO TO 2.

2. CHECK REAR WINDOW DEFOGGER SWITCH CIRCUIT

1. Disconnect BCM connector.
2. Check continuity between BCM harness connector and A/C auto amp. harness connector.

BCM		A/C auto amp.		Continuity
Connector	Terminal	Connector	Terminal	
M68	15	M51	33	Existed

3. Check continuity between BCM harness connector and ground.

BCM		Ground	Continuity
Connector	Terminal		
M68	15		Not existed

Is the inspection result normal?

- YES >> Replace BCM. Refer to [BCS-82, "Removal and Installation"](#).
 NO >> Repair or replace harness.

A
B
C
D
E
F
G
H
I
J
K

DEF

M
N
O
P

REAR WINDOW DEFOGGER SWITCH

< DTC/CIRCUIT DIAGNOSIS >

3.CHECK GROUND CIRCUIT

Check continuity between A/C auto amp. harness connector and ground.

A/C auto amp.		Ground	Continuity
Connector	Terminal		
M50	16		Existed

Is the inspection result normal?

- YES >> GO TO 4.
NO >> Repair or replace harness.

4.CHECK REAR WINDOW DEFOGGER SWITCH

Refer to [DEF-26, "WITH AUTO A/C : Component Inspection"](#).

Is the inspection result normal?

- YES >> GO TO 5.
NO >> Replace A/C auto amp. Refer to [HAC-144, "Removal and Installation"](#).

5.CHECK INTERMITTENT INCIDENT

Refer to [GI-34, "Intermittent Incident"](#).

Is the inspection result normal?

>> INSPECTION END

WITH AUTO A/C : Component Inspection

INFOID:000000005049259

1.CHECK REAR WINDOW DEFOGGER SWITCH

1. Turn ignition switch OFF.
2. Disconnect A/C auto amp. connector.
3. Check continuity between A/C auto amp. terminals.

A/C auto amp.		Condition	Continuity
Terminal			
16	33	Rear window defogger switch	Pressed Existed
			Released Not existed

Is the inspection result normal?

- YES >> INSPECTION END
NO >> Replace A/C auto amp. Refer to [HAC-144, "Removal and Installation"](#).

WITHOUT AUTO A/C

WITHOUT AUTO A/C : Description

INFOID:000000005071705

- The rear window defogger is operated by turning the rear window defogger switch ON.
- The indicator lamp in the rear window defogger illuminates when the rear window defogger is operating.

WITHOUT AUTO A/C : Component Function Check

INFOID:000000005071701

1.CHECK FUNCTION

Check (REAR DEF SW) in BCM "DATA MONITOR" mode using CONSULT-III when rear window defogger switch is ON.

Is the inspection result normal?

- YES >> Rear window defogger switch function is OK.
NO >> Refer to [DEF-26, "WITHOUT AUTO A/C : Diagnosis Procedure"](#)

WITHOUT AUTO A/C : Diagnosis Procedure

INFOID:000000005049262

1.CHECK BCM OUTPUT SIGNAL

REAR WINDOW DEFOGGER SWITCH

< DTC/CIRCUIT DIAGNOSIS >

1. Turn ignition switch OFF.
2. Disconnect A/C control connector.
3. Check voltage between A/C control harness connector and ground.

A
B
C

(+)		(-)	Voltage (V) (Approx.)
A/C control			
Connector	Terminal	Ground	12
M53	5		

Is the inspection result normal?

- YES >> GO TO 3.
NO >> GO TO 2.

D

2.CHECK REAR WINDOW DEFOGGER SWITCH CIRCUIT

1. Disconnect BCM connector.
2. Check continuity between BCM harness connector and A/C control harness connector.

E
F

BCM		A/C control		Continuity
Connector	Terminal	Connector	Terminal	
M65	10	M53	5	Existed

3. Check continuity between BCM harness connector and ground.

G

BCM		Ground	Continuity
Connector	Terminal		
M65	10		Not existed

H

Is the inspection result normal?

- YES >> Replace BCM. Refer to [BCS-82, "Removal and Installation"](#).
NO >> Repair or replace harness.

I

3.CHECK GROUND CIRCUIT

Check continuity between A/C control harness connector and ground.

J

A/C control		Ground	Continuity
Connector	Terminal		
M53	15		Existed

K

Is the inspection result normal?

- YES >> GO TO 4.
NO >> Repair or replace harness.

M

4.CHECK REAR WINDOW DEFOGGER SWITCH

Refer to [DEF-27, "WITHOUT AUTO A/C : Component Inspection"](#).

Is the inspection result normal?

- YES >> GO TO 5.
NO >> Replace A/C control. Refer to [HAC-222, "Removal and Installation"](#).

N

5.CHECK INTERMITTENT INCIDENT

Refer to [GI-34, "Intermittent Incident"](#).

Is the inspection result normal?

>> INSPECTION END

O

P

WITHOUT AUTO A/C : Component Inspection

INFOID:000000005049263

1.CHECK REAR WINDOW DEFOGGER SWITCH

1. Turn ignition switch OFF.
2. Disconnect A/C control connector.

REAR WINDOW DEFOGGER SWITCH

< DTC/CIRCUIT DIAGNOSIS >

3. Check continuity between A/C control terminals.

A/C control		Condition	Continuity
Terminal			
5	15	Rear window defogger switch	Pressed Existed
			Released Not existed

Is the inspection result normal?

YES >> INSPECTION END

NO >> Replace A/C control. Refer to [HAC-222, "Removal and Installation"](#).

WITHOUT A/C

WITHOUT A/C : Description

INFOID:000000005129801

- The rear window defogger is operated by turning the rear window defogger switch ON.
- The indicator lamp in the rear window defogger illuminates when the rear window defogger is operating.

WITHOUT A/C : Component Function Check

INFOID:000000005129803

1.CHECK FUNCTION

Check (REAR DEF SW) in BCM "DATA MONITOR" mode using CONSULT-III when rear window defogger switch is ON.

Is the inspection result normal?

YES >> Rear window defogger switch function is OK.

NO >> Refer to [DEF-28, "WITHOUT A/C : Diagnosis Procedure"](#)

WITHOUT A/C : Diagnosis Procedure

INFOID:000000005129805

1.CHECK BCM OUTPUT SIGNAL

1. Turn ignition switch OFF.
2. Disconnect heater control connector.
3. Check voltage between heater control harness connector and ground.

(+)		(-)	Voltage (V) (Approx.)
Heater control			
Connector	Terminal		
M28	5	Ground	12

Is the inspection result normal?

YES >> GO TO 3.

NO >> GO TO 2.

2.CHECK REAR WINDOW DEFOGGER SWITCH CIRCUIT

1. Disconnect BCM connector.
2. Check continuity between BCM harness connector and heater control harness connector.

BCM		Heater control		Continuity
Connector	Terminal	Connector	Terminal	
M65	10	M28	5	Existed

3. Check continuity between BCM harness connector and ground.

BCM		Ground	Continuity
Connector	Terminal		
M65	10		Not existed

Is the inspection result normal?

REAR WINDOW DEFOGGER SWITCH

< DTC/CIRCUIT DIAGNOSIS >

- YES >> Replace BCM. Refer to [BCS-148. "Removal and Installation"](#).
 NO >> Repair or replace harness.

3.CHECK GROUND CIRCUIT

Check continuity between heater control harness connector and ground.

Heater control		Ground	Continuity
Connector	Terminal		
M28	15		Existed

Is the inspection result normal?

- YES >> GO TO 4.
 NO >> Repair or replace harness.

4.CHECK REAR WINDOW DEFOGGER SWITCH

Refer to [DEF-29. "WITHOUT A/C : Component Inspection"](#).

Is the inspection result normal?

- YES >> GO TO 5.
 NO >> Replace heater control. Refer to [HAC-280. "Removal and Installation"](#).

5.CHECK INTERMITTENT INCIDENT

Refer to [GI-34. "Intermittent Incident"](#).

Is the inspection result normal?

>> INSPECTION END

WITHOUT A/C : Component Inspection

INFOID:000000005129806

1.CHECK REAR WINDOW DEFOGGER SWITCH

1. Turn ignition switch OFF.
2. Disconnect heater control connector.
3. Check continuity between heater control terminals.

Heater control		Condition	Continuity
Terminal			
5	15	Rear window defogger switch	Pressed
			Released
			Existed
			Not existed

Is the inspection result normal?

- YES >> INSPECTION END
 NO >> Replace heater control. Refer to [HAC-280. "Removal and Installation"](#).

A
B
C
D
E
F
G
H
I
J
K
M
N
O
P

DEF

REAR WINDOW DEFOGGER RELAY

< DTC/CIRCUIT DIAGNOSIS >

REAR WINDOW DEFOGGER RELAY

Description

INFOID:000000005049264

The rear window defogger is operated by turning the rear window defogger switch ON.

Component Function Check

INFOID:000000005071702

1.CHECK FUNCTION

1. Perform IPDM E/R Active Test ("REAR DEFOGGER") using CONSULT-III.
2. Touch "ON".
3. Check that the rear window heating wire is getting warmer.

Is the inspection result normal?

- YES >> Rear window defogger relay function is OK.
NO >> Refer to [DEF-30, "Diagnosis Procedure"](#)

Diagnosis Procedure

INFOID:000000005049266

1.CHECK FUSE

1. Turn ignition switch OFF.
2. Check the 15A fuse (No. 41 and No. 42 located in IPDM E/R).

Is the inspection result normal?

- YES >> GO TO 2.
NO >> Replace the blown fuse after repairing the affected circuit if a fuse is blown.

2.CHECK IPDM E/R OUTPUT SIGNAL

1. Perform IPDM E/R Active Test ("REAR DEFOGGER") using CONSULT-III.
2. Touch "ON".
3. Check voltage between IPDM E/R harness connector and ground.

(+)		(-)	CONSULT-III Active Test condition	Voltage (V) (Approx.)	
IPDM E/R					
Connector	Terminal				
E11	13	Ground	REAR DEFOGGER	ON	Battery voltage
				OFF	0

Is the inspection result normal?

- YES >> INSPECTION END
NO >> Replace IPDM E/R. Refer to [PCS-35, "Removal and Installation"](#).

REAR WINDOW DEFOGGER

< DTC/CIRCUIT DIAGNOSIS >

REAR WINDOW DEFOGGER

Description

INFOID:000000005049267

Heats the heating wire with the power supply from the rear window defogger relay to prevent the rear window from fogging up.

Component Function Check

INFOID:000000005071703

1.CHECK FUNCTION

1. Perform IPDM E/R Active Test ("REAR DEFOGGER") using CONSULT-III.
2. Touch "ON".
3. Check that the rear window heating wire is getting warmer.

Is the inspection result normal?

- YES >> Rear window defogger relay function is OK.
 NO >> Refer to [DEF-30, "Diagnosis Procedure"](#)

Diagnosis Procedure

INFOID:000000005049269

1.CHECK REAR WINDOW DEFOGGER POWER SUPPLY CIRCUIT

1. Turn ignition switch OFF.
2. Disconnect rear window defogger connector.
3. Turn ignition switch ON.
4. Check voltage between rear window defogger harness connector and ground.

(+)		(-)	Condition	Voltage (V) (Approx.)
Connector	Terminal			
D201	1	Ground	Rear window defogger switch	ON OFF
				Battery voltage 0

Is the inspection result normal?

- YES >> GO TO 2.
 NO >> GO TO 4.

2.CHECK REAR WINDOW DEFOGGER GROUND CIRCUIT

1. Turn ignition switch OFF.
2. Check continuity between rear window defogger harness connector and ground.

Rear window defogger		Ground	Continuity
Connector	Terminal		
D104	2		Existed

Is the inspection result normal?

- YES >> GO TO 3.
 NO >> Repair or replace harness.

3.CHECK FILAMENT

Refer to [DEF-131, "Inspection and Repair"](#).

Is the inspection result normal?

- YES >> GO TO 5.
 NO >> Repair filament.

4.CHECK REAR WINDOW DEFOGGER POWER SUPPLY CIRCUIT 1

1. Turn ignition switch OFF.
2. Disconnect condenser connector.
3. Check continuity between condenser harness connector and rear window defogger harness connector.

REAR WINDOW DEFOGGER

< DTC/CIRCUIT DIAGNOSIS >

Condenser		Rear window defogger		Continuity
Connector	Terminal	Connector	Terminal	
D202	2	D201	1	Existed

4. Check continuity between condenser connector and ground.

Condenser		Ground	Continuity
Connector	Terminal		
D202	2		Not existed

Is the inspection result normal?

YES >> GO TO 5.

NO >> Repair or replace harness.

5.CHECK REAR WINDOW DEFOGGER POWER SUPPLY CIRCUIT 2

1. Disconnect IPDM E/R connectors.
2. Check continuity between IPDM E/R harness connector and condenser harness connector.

IPDM E/R		Condenser		Continuity
Connector	Terminal	Connector	Terminal	
E11	13	D103	1	Existed

3. Check continuity between IPDM E/R connector and ground.

IPDM E/R		Ground	Continuity
Connector	Terminal		
E11	13		Not existed

Is the inspection result normal?

YES >> GO TO 6.

NO >> Repair or replace harness.

6.CHECK CONDENSER

Refer to [DEF-32. "Component Inspection"](#).

Is the inspection result normal?

YES >> GO TO 7.

NO >> Replace condenser. Refer to [DEF-133. "Removal and Installation"](#).

7.CHECK INTERMITTENT INCIDENT

Refer to [GI-34. "Intermittent Incident"](#)

Is the inspection result normal?

YES >> INSPECTION END

NO >> Repair or replace harness or connector.

Component Inspection

INFOID:000000005071706

1.CHECK CONDENSER

1. Turn ignition switch OFF.
2. Disconnect condenser connector.
3. Check continuity between condenser connector and ground part of condenser.

Condenser		Ground part of condenser	Continuity
Connector	Terminal		
D103	1		Not existed
D202	2		

4. Check continuity between condenser terminals.

REAR WINDOW DEFOGGER

< DTC/CIRCUIT DIAGNOSIS >

Condenser				Continuity
Connector	Terminal	Connector	Terminal	
D103	1	D202	2	Existed

Is the inspection result normal?

YES >> INSPECTION END

NO >> Replace condenser. Refer to [DEF-133. "Removal and Installation"](#).

A
B
C
D
E
F
G
H
I
J
K
DEF
M
N
O
P

DEF

DOOR MIRROR DEFOGGER

< DTC/CIRCUIT DIAGNOSIS >

DOOR MIRROR DEFOGGER

Description

INFOID:000000005049311

Heats the heating wire with the power supply from the rear window defogger relay to prevent the door mirror from fogging up.

Component Function Check

INFOID:000000005049312

1.CHECK DOOR MIRROR DEFOGGER

1. Perform IPDM E/R Active Test ("REAR DEFOGGER") using CONSULT-III.
2. Touch "ON".
3. Check that both side door mirror glass is getting warmer.

Is the inspection result normal?

- YES >> Door mirror defogger is OK.
NO >> Refer to [DEF-34, "Diagnosis Procedure"](#)

Diagnosis Procedure

INFOID:000000005049313

1.CHECK FUSE

1. Turn ignition switch OFF.
2. Check 10A fuse [No.5, located in fuse block (J/B)].

Is the inspection result normal?

- YES >> GO TO 2.
NO >> Replace the blown fuse after repairing the affected circuit if a fuse is blown.

2.CHECK DOOR MIRROR DEFOGGER CIRCUIT

1. Disconnect IPDM E/R connector and door mirror (both sides) connector.
2. Check continuity between IPDM E/R harness connector and door mirror (driver side) harness connector.

IPDM E/R		Door mirror (driver side)		Continuity
Connector	Terminal	Connector	Terminal	
E11	13	D3	3	Existed

3. Check continuity between IPDM E/R harness connector and ground.

IPDM E/R		Ground	Continuity
Connector	Terminal		
E11	13		Not existed

Is the inspection result normal?

- YES >> GO TO 3.
NO >> Repair or replace harness.

3.CHECK INTERMITTENT INCIDENT

Check intermittent incident.

Refer to [GI-34, "Intermittent Incident"](#).

>> INSPECTION END

DRIVER SIDE DOOR MIRROR DEFOGGER

< DTC/CIRCUIT DIAGNOSIS >

DRIVER SIDE DOOR MIRROR DEFOGGER

Description

INFOID:000000005049314

Heats the heating wire with the power supply from the rear window defogger relay to prevent the door mirror from fogging up.

Component Function Check

INFOID:000000005049315

1.CHECK DRIVER SIDE DOOR MIRROR DEFOGGER

1. Perform IPDM E/R Active Test ("REAR DEFOGGER") using CONSULT-III.
2. Touch "ON".
3. Check that the driver side door mirror glass is getting warmer.

Is the inspection result normal?

- YES >> Driver side door mirror defogger is OK.
 NO >> Refer to [DEF-35, "Diagnosis Procedure"](#)

Diagnosis Procedure

INFOID:000000005049316

1.CHECK POWER SUPPLY CIRCUIT

1. Turn ignition switch OFF.
2. Disconnect door mirror (driver side) connector.
3. Turn ignition switch ON.
4. Check voltage between door mirror (driver side) harness connector and ground.

(+)		(-)	Condition	Voltage (V) (Approx.)
Door mirror (driver side) Connector	Terminal			
D3	3	Ground	Rear window defogger switch	ON Battery voltage
			OFF 0	

Is the inspection result normal?

- YES >> GO TO 2.
 NO >> Repair or replace harness.

2.CHECK GROUND CIRCUIT

1. Turn ignition switch OFF.
2. Check continuity between door mirror (driver side) harness connector and ground.

Door mirror (driver side)		Ground	Continuity
Connector	Terminal		
D3	2		Existed

Is the inspection result normal?

- YES >> Replace door mirror glass (driver side). Refer to [MIR-17, "GLASS MIRROR : Disassembly and Assembly"](#)
 NO >> Repair or replace harness.

A
B
C
D
E
F
G
H
I
J
K
M
N
O
P

DEF

PASSENGER SIDE DOOR MIRROR DEFOGGER

< DTC/CIRCUIT DIAGNOSIS >

PASSENGER SIDE DOOR MIRROR DEFOGGER

Description

INFOID:000000005049317

Heats the heating wire with the power supply from the rear window defogger relay to prevent the door mirror from fogging up.

Component Function Check

INFOID:000000005049318

1.CHECK PASSENGER SIDE DOOR MIRROR DEFOGGER

1. Perform IPDM E/R Active Test ("REAR DEFOGGER") using CONSULT-III.
2. Touch "ON".
3. Check that the passenger side door mirror glass is getting warmer.

Is the inspection result normal?

- YES >> Passenger side door mirror defogger is OK.
NO >> Refer to [DEF-36, "Diagnosis Procedure"](#)

Diagnosis Procedure

INFOID:000000005049319

1.CHECK POWER SUPPLY CIRCUIT

1. Turn ignition switch OFF.
2. Disconnect door mirror (passenger side) connector.
3. Turn ignition switch ON.
4. Check voltage between door mirror (passenger side) harness connector and ground.

(+)		(-)	Condition		Voltage (V) (Approx.)
Door mirror (passenger side) Connector	Terminal				
D23	3	Ground	Rear window defogger switch	ON	Battery voltage
				OFF	0

Is the inspection result normal?

- YES >> GO TO 2.
NO >> Repair or replace harness.

2.CHECK GROUND CIRCUIT

1. Turn ignition switch OFF.
2. Check continuity between door mirror (passenger side) harness connector and ground.

Door mirror (passenger side)		Ground	Continuity
Connector	Terminal		
D23	2		Existed

Is the inspection result normal?

- YES >> Replace door mirror glass (passenger side). Refer to [MIR-17, "GLASS MIRROR : Disassembly and Assembly"](#)
NO >> Repair or replace harness.

REAR WINDOW DEFOGGER ON SIGNAL

< DTC/CIRCUIT DIAGNOSIS >

REAR WINDOW DEFOGGER ON SIGNAL WITH AUTO A/C

WITH AUTO A/C : Description

INFOID:000000005049271

Turns the indicator lamp in the rear window defogger switch ON when operating the rear window defogger.

WITH AUTO A/C : Component Function Check

INFOID:000000005049272

1.CHECK REAR WINDOW DEFOGGER ON SIGNAL

Check that the indicator lamps of rear window defogger switch are illuminated when turning the rear window defogger switch ON.

Is the inspection result normal?

- OK >> Rear window defogger ON signal is OK.
- NG >> Refer to [DEF-37, "WITH AUTO A/C : Diagnosis Procedure"](#).

WITH AUTO A/C : Diagnosis Procedure

INFOID:000000005049273

1.CHECK REAR WINDOW DEFOGGER INDICATOR LAMPS ON SIGNAL

1. Turn ignition switch OFF.
2. Disconnect A/C auto amp. connector.
3. Turn ignition switch ON.
4. Check voltage between A/C auto amp. harness connector ground.

A/C auto amp.		Ground	Condition		Voltage (V) (Approx.)
Connector	Terminal		Rear window defogger switch		
M51	27			ON	
			OFF		0

Is the inspection result normal?

- YES >> Replace A/C auto amp. Refer to [HAC-144, "Removal and Installation"](#).
- NO >> Repair or replace harness.

WITHOUT AUTO A/C

WITHOUT AUTO A/C : Description

INFOID:000000005049274

Turns the indicator lamp in the rear window defogger switch ON when operating the rear window defogger.

WITHOUT AUTO A/C : Component Function Check

INFOID:000000005049275

1.CHECK REAR WINDOW DEFOGGER ON SIGNAL

Check that the indicator lamps of rear window defogger switch are illuminated when turning the rear window defogger switch ON.

Is the inspection result normal?

- OK >> Rear window defogger ON signal is OK.
- NG >> Refer to [DEF-37, "WITHOUT AUTO A/C : Diagnosis Procedure"](#).

WITHOUT AUTO A/C : Diagnosis Procedure

INFOID:000000005049276

1.CHECK REAR WINDOW DEFOGGER INDICATOR LAMPS ON SIGNAL

1. Turn ignition switch OFF.
2. Disconnect A/C control connector.
3. Turn ignition switch ON.
4. Check voltage between A/C control harness connector ground.

REAR WINDOW DEFOGGER ON SIGNAL

< DTC/CIRCUIT DIAGNOSIS >

A/C control		Ground	Condition		Voltage (V) (Approx.)
Connector	Terminal				
M53	4		Rear window defogger switch	ON	Battery voltage
				OFF	0

Is the inspection result normal?

- YES >> Replace A/C control. Refer to [HAC-222. "Removal and Installation"](#).
NO >> Repair or replace harness.

WITHOUT A/C

WITHOUT A/C : Description

INFOID:000000005129807

Turns the indicator lamp in the rear window defogger switch ON when operating the rear window defogger.

WITHOUT A/C : Component Function Check

INFOID:000000005129808

1.CHECK REAR WINDOW DEFOGGER ON SIGNAL

Check that the indicator lamps of rear window defogger switch are illuminated when turning the rear window defogger switch ON.

Is the inspection result normal?

- OK >> Rear window defogger ON signal is OK.
NG >> Refer to [DEF-38. "WITHOUT A/C : Diagnosis Procedure"](#).

WITHOUT A/C : Diagnosis Procedure

INFOID:000000005129809

1.CHECK REAR WINDOW DEFOGGER INDICATOR LAMPS ON SIGNAL

1. Turn ignition switch OFF.
2. Disconnect heater control connector.
3. Turn ignition switch ON.
4. Check voltage between heater control harness connector ground.

Heater control		Ground	Condition		Voltage (V) (Approx.)
Connector	Terminal				
M28	4		Rear window defogger switch	ON	Battery voltage
				OFF	0

Is the inspection result normal?

- YES >> Replace heater control. Refer to [HAC-280. "Removal and Installation"](#).
NO >> Repair or replace harness.

REAR WINDOW DEFOGGER SYSTEM

< DTC/CIRCUIT DIAGNOSIS >

DEFOGGER









Connector No. B6	WIRE TO WIRE M02MW-LC		Terminal No. 2	Color of Wire R	Signal Name [Specification] -
Connector No. B19	WIRE TO WIRE M02MW-LC		Terminal No. 1	Color of Wire R	Signal Name [Specification] -
Connector No. D2	WIRE TO WIRE M10DFW-CS		Terminal No. 4	Color of Wire G	Signal Name [Specification] -
Connector No. D3	DOOR MIRROR (DRIVER SIDE) TH08MW-NH		Terminal No. 2	Color of Wire B	Signal Name [Specification] -
Connector No. D21	WIRE TO WIRE NH10FW-CS10		Terminal No. 9	Color of Wire R	Signal Name [Specification] -
Connector No. D23	DOOR MIRROR (PASSENGER SIDE) TH08MW-NH		Terminal No. 2	Color of Wire B	Signal Name [Specification] -
Connector No. D101	WIRE TO WIRE M02MW-LC		Terminal No. 1	Color of Wire R	Signal Name [Specification] -
Connector No. D03	CONDENSER P01FB-A		Terminal No. 1	Color of Wire R	Signal Name [Specification] -

JCLWM3542GB

REAR WINDOW DEFOGGER SYSTEM

< DTC/CIRCUIT DIAGNOSIS >

DEFOGGER

Connector No. D104	Connector Name REAR WINDOW DEFOGGER	Connector Type P01FE-A	 2	Signal Name [Specification]	Terminal No. 2	Color of Wire B	Signal Name [Specification]	Terminal No. 1	Color of Wire R	Signal Name [Specification]	Terminal No. 1	Color of Wire B	Signal Name [Specification]
Connector No. D123	Connector Name WIRE TO WIRE	Connector Type M02FW-LC	 1 2	Signal Name [Specification]	Terminal No. 1	Color of Wire R	Signal Name [Specification]	Terminal No. 1	Color of Wire R	Signal Name [Specification]	Terminal No. 1	Color of Wire B	Signal Name [Specification]
Connector No. D126	Connector Name WIRE TO WIRE	Connector Type M04FW-LC	 2 1 4 3	Signal Name [Specification]	Terminal No. 1	Color of Wire R	Signal Name [Specification]	Terminal No. 1	Color of Wire R	Signal Name [Specification]	Terminal No. 1	Color of Wire B	Signal Name [Specification]
Connector No. D201	Connector Name REAR WINDOW DEFOGGER	Connector Type P01FB-A	 1	Signal Name [Specification]	Terminal No. 1	Color of Wire B	Signal Name [Specification]	Terminal No. 1	Color of Wire B	Signal Name [Specification]	Terminal No. 1	Color of Wire B	Signal Name [Specification]
Connector No. D202	Connector Name CONDENSER	Connector Type P01FE-A	 2	Signal Name [Specification]	Terminal No. 2	Color of Wire B	Signal Name [Specification]	Terminal No. 1	Color of Wire R	Signal Name [Specification]	Terminal No. 1	Color of Wire B	Signal Name [Specification]
Connector No. E11	Connector Name IPDM E/R (INTELLIGENT POWER DISTRIBUTION MODULE ENGINE ROOM)	Connector Type M06FB-LC	 10 9 13	Signal Name [Specification]	Terminal No. 9	Color of Wire B/W	Signal Name [Specification]	Terminal No. 19	Color of Wire B/W	Signal Name [Specification]	Terminal No. 19	Color of Wire B/W	Signal Name [Specification]
Connector No. E12	Connector Name IPDM E/R (INTELLIGENT POWER DISTRIBUTION MODULE ENGINE ROOM)	Connector Type NS08FB-CS	 22 21 19 18	Signal Name [Specification]	Terminal No. 19	Color of Wire B/W	Signal Name [Specification]	Terminal No. 19	Color of Wire B/W	Signal Name [Specification]	Terminal No. 19	Color of Wire B/W	Signal Name [Specification]
Connector No. E13	Connector Name IPDM E/R (INTELLIGENT POWER DISTRIBUTION MODULE ENGINE ROOM)	Connector Type TH12FW-NH	 28 27 26 25 24 31 30 33	Signal Name [Specification]	Terminal No. 26	Color of Wire P	Signal Name [Specification]	Terminal No. 26	Color of Wire P	Signal Name [Specification]	Terminal No. 26	Color of Wire P	Signal Name [Specification]
Terminal No. 2	Color of Wire B	Signal Name [Specification]	Terminal No. 13	Color of Wire W	Signal Name [Specification]	Terminal No. 13	Color of Wire W	Terminal No. 27	Color of Wire L	Signal Name [Specification]	Terminal No. 27	Color of Wire L	Signal Name [Specification]

A
B
C
D
E
F
G
H
I
J
K
DEF
M
N
O
P

REAR WINDOW DEFOGGER SYSTEM

< DTC/CIRCUIT DIAGNOSIS >

DEFOGGER

Connector No. E105	WIRE TO WIRE TH80WV-CS1F-TM4		Terminal No. 80	Color of Wire P	Signal Name [Specification]	Terminal No. 4	Color of Wire G/R	Signal Name [Specification]
Connector Name			81	L		5	W/L	
Connector Type			91	W		15	B	
			96	LG				
Connector No. M28	HEATER CONTROL TH18FW-NH		Terminal No. 4	R	Signal Name [Specification]	Terminal No. 4	R	Signal Name [Specification]
Connector Name			5	W/L		5	W/L	
Connector Type			15	B		15	B	
Connector No. M22	WIRE TO WIRE NH10WV-CS10		Terminal No. 9	G/R	Signal Name [Specification]	Terminal No. 4	R	Signal Name [Specification]
Connector Name			14	B		5	W/L	
Connector Type						15	B	
Connector No. M4	DATA LINK CONNECTOR BD18FW		Terminal No. 6	L	Signal Name [Specification]	Terminal No. 4	R	Signal Name [Specification]
Connector Name			14	P		5	W/L	
Connector Type						15	B	
Connector No. M53	A/C CONTROL TH18FW-NH		Terminal No. 9	G/R	Signal Name [Specification]	Terminal No. 4	R	Signal Name [Specification]
Connector Name			14	B		5	W/L	
Connector Type						15	B	
Connector No. M51	A/C AUTO AMP. TK18FGY		Terminal No. 27	R	Signal Name [Specification]	Terminal No. 4	R	Signal Name [Specification]
Connector Name			33	W/L	REAR WINDOW DEFOGGER F/B SIGNAL	5	W/L	
Connector Type					REAR WINDOW DEFOGGER ON SIGNAL	15	B	
Connector No. M60	A/C AUTO AMP. TK20FGY		Terminal No. 16	B	Signal Name [Specification]	Terminal No. 4	R	Signal Name [Specification]
Connector Name					GROUND	5	W/L	
Connector Type						15	B	
Connector No. M40	WIRE TO WIRE NS10WV-CS		Terminal No. 4	G/R	Signal Name [Specification]	Terminal No. 4	R	Signal Name [Specification]
Connector Name			10	B		5	W/L	
Connector Type						15	B	

JCLWM3544GB

REAR WINDOW DEFOGGER SYSTEM

< DTC/CIRCUIT DIAGNOSIS >

DEFOGGER

Connector No.	M70
Connector Name	ECM (BODY CONTROL MODULE) (WITH INTELLIGENT KEY)
Connector Type	FEA09FB-FHA6-SA



Terminal No.	Color of Wire	Signal Name [Specification]
67	B	GND
70	Y	BAT (F/L)

Connector No.	M68
Connector Name	ECM (BODY CONTROL MODULE) (WITH INTELLIGENT KEY)
Connector Type	THA9FB-NH



Terminal No.	Color of Wire	Signal Name [Specification]
15	W/L	REAR WINDOW DEFOGGER SW
38	O	IGN F/B
39	L	CAN-H
40	P	CAN-L

Connector No.	M67
Connector Name	ECM (BODY CONTROL MODULE) (WITHOUT INTELLIGENT KEY)
Connector Type	FEA09FB-FHA6-SA



Terminal No.	Color of Wire	Signal Name [Specification]
67	B	GND
70	Y	BAT (F/L)

Connector No.	M89
Connector Name	WIRE TO WIRE
Connector Type	MD4FW-LC



Terminal No.	Color of Wire	Signal Name [Specification]
2	R	-

Connector No.	M65
Connector Name	ECM (BODY CONTROL MODULE) (WITHOUT INTELLIGENT KEY)
Connector Type	THA9FW-NH



Terminal No.	Color of Wire	Signal Name [Specification]
10	W/L	REAR WINDOW DEFOGGER SW
38	O	IGN
39	L	CAN-H
40	P	CAN-L

Connector No.	M77
Connector Name	WIRE TO WIRE
Connector Type	THB0FW-CS16-TM4

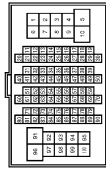

Terminal No.	Color of Wire	Signal Name [Specification]
80	P	-
81	L	-
91	R	-
96	Y	-

JCLWM3545GB

A
B
C
D
E
F
G
H
I
J
K
DEF
M
N
O
P

BCM (BODY CONTROL MODULE)

< ECU DIAGNOSIS INFORMATION >

ECU DIAGNOSIS INFORMATION

BCM (BODY CONTROL MODULE) WITH INTELLIGENT KEY

WITH INTELLIGENT KEY : Reference Value

INFOID:000000005133230

VALUES ON THE DIAGNOSIS TOOL

CONSULT-III MONITOR ITEM

Monitor Item	Condition	Value/Status
FR WIPER HI	Other than front wiper switch HI	Off
	Front wiper switch HI	On
FR WIPER LOW	Other than front wiper switch LO	Off
	Front wiper switch LO	On
FR WASHER SW	Front washer switch OFF	Off
	Front washer switch ON	On
FR WIPER INT	Other than front wiper switch INT/AUTO	Off
	Front wiper switch INT/AUTO	On
FR WIPER STOP	Front wiper is not in STOP position	Off
	Front wiper is in STOP position	On
INT VOLUME	Wiper intermittent dial is in a dial position 1 - 7	Wiper intermittent dial position
RR WIPER ON	Other than rear wiper switch ON	Off
	Rear wiper switch ON	On
RR WIPER INT	Other than rear wiper switch INT	Off
	Rear wiper switch INT	On
RR WASHER SW	Rear washer switch OFF	Off
	Rear washer switch ON	On
RR WIPER STOP	Rear wiper is in STOP position	Off
	Rear wiper is not in STOP position	On
TURN SIGNAL R	Other than turn signal switch RH	Off
	Turn signal switch RH	On
TURN SIGNAL L	Other than turn signal switch LH	Off
	Turn signal switch LH	On
TAIL LAMP SW	Other than lighting switch 1ST and 2ND	Off
	Lighting switch 1ST or 2ND	On
HI BEAM SW	Other than lighting switch HI	Off
	Lighting switch HI	On
HEAD LAMP SW 1	Other than lighting switch 2ND	Off
	Lighting switch 2ND	On
HEAD LAMP SW 2	Other than lighting switch 2ND	Off
	Lighting switch 2ND	On
PASSING SW	Other than lighting switch PASS	Off
	Lighting switch PASS	On
AUTO LIGHT SW	Other than lighting switch AUTO	Off
	Lighting switch AUTO	On

BCM (BODY CONTROL MODULE)

< ECU DIAGNOSIS INFORMATION >

Monitor Item	Condition	Value/Status	
FR FOG SW	Front fog lamp switch OFF	Off	A
	Front fog lamp switch ON	On	
DOOR SW-DR	Driver door closed	Off	B
	Driver door opened	On	
DOOR SW-AS	Passenger door closed	Off	C
	Passenger door opened	On	
DOOR SW-RR	Rear RH door closed	Off	D
	Rear RH door opened	On	
DOOR SW-RL	Rear LH door closed	Off	E
	Rear LH door opened	On	
DOOR SW-BK	Back door closed	Off	F
	Back door opened	On	
CDL LOCK SW	Other than power door lock switch LOCK	Off	G
	Power door lock switch LOCK	On	
CDL UNLOCK SW	Other than power door lock switch UNLOCK	Off	H
	Power door lock switch UNLOCK	On	
KEY CYL LK-SW	Other than driver door key cylinder LOCK position	Off	I
	Driver door key cylinder LOCK position	On	
KEY CYL UN-SW	Other than driver door key cylinder UNLOCK position	Off	J
	Driver door key cylinder UNLOCK position	On	
HAZARD SW	Hazard switch is OFF	Off	K
	Hazard switch is ON	On	
REAR DEF SW	Rear window defogger switch OFF	Off	
	Rear window defogger switch ON	On	
TR/BD OPEN SW	NOTE: The item is indicated, but not monitored.	Off	
TRNK/HAT MNTR	NOTE: The item is indicated, but not monitored.	Off	
FAN ON SIG	Blower fan OFF	Off	DEF
	Blower fan ON	On	
AIR COND SW	Air conditioner OFF (A/C switch indicator OFF)	Off	
	Air conditioner ON (A/C switch indicator ON)	On	M
RKE-LOCK	LOCK button of the key is not pressed	Off	
	LOCK button of the key is pressed	On	
RKE-UNLOCK	UNLOCK button of the key is not pressed	Off	N
	UNLOCK button of the key is pressed	On	
RKE-TR/BD	BACK DOOR OPEN button of the key is not pressed	Off	O
	BACK DOOR OPEN button of the key is pressed	On	
RKE-PANIC	PANIC button of the key is not pressed	Off	P
	PANIC button of the key is pressed	On	
RKE-MODE CHG	LOCK/UNLOCK button of the key is not pressed and held simultaneously	Off	
	LOCK/UNLOCK button of the key is pressed and held simultaneously	On	
OPTI SEN (DTCT)	Bright outside of the vehicle	Close to 5 V	
	Dark outside of the vehicle	Close to 0 V	

BCM (BODY CONTROL MODULE)

< ECU DIAGNOSIS INFORMATION >

Monitor Item	Condition	Value/Status
OPTI SEN (FILT)	Bright outside of the vehicle (Lighting switch AUTO)	Close to 5 V
	Dark outside of the vehicle (Lighting switch AUTO)	Close to 1.50 V
OPTICAL SENSOR	NOTE: The item is indicated, but not monitored.	Off
RAIN SENSOR	NOTE: The item is indicated, but not monitored.	Off
REQ SW -DR	Driver door request switch is not pressed	Off
	Driver door request switch is pressed	On
REQ SW -AS	Passenger door request switch is not pressed	Off
	Passenger door request switch is pressed	On
REQ SW -RR	NOTE: The item is indicated, but not monitored.	Off
REQ SW -RL	NOTE: The item is indicated, but not monitored.	Off
REQ SW -BD/TR	Back door request switch is not pressed	Off
	Back door request switch is pressed	On
PUSH SW	Push-button ignition switch (push switch) is not pressed	Off
	Push-button ignition switch (push switch) is pressed	On
CLUCH SW	NOTE: The item is indicated, but not monitored.	Off
BRAKE SW 1	The brake pedal is not depressed	Off
	The brake pedal is depressed	On
BRAKE SW 2	The brake pedal is depressed when No. 7 fuse is blown	Off
	The brake pedal is not depressed when No. 7 fuse is blown, or No. 7 fuse is normal	On
DETE/CANCL SW	Selector lever in P position	Off
	Selector lever in any position other than P	On
SFT PN/N SW	Selector lever in any position other than P and N	Off
	Selector lever in P or N position	On
S/L -LOCK	Steering is locked	Off
	Steering is unlocked	On
S/L -UNLOCK	Steering is unlocked	Off
	Steering is locked	On
S/L RELAY-F/B	Steering is unlocked	Off
	Steering is locked	On
UNLK SEN -DR	Driver door is locked	Off
	Driver door is unlocked	On
PUSH SW -IPDM	Push-button ignition switch (push-switch) is not pressed	Off
	Push-button ignition switch (push-switch) is pressed	On
IGN RLY1 -F/B	Ignition switch in OFF or ACC position	Off
	Ignition switch in ON position	On
DETE SW -IPDM	Selector lever in any position other than P	Off
	Selector lever in P position	On
SFT PN -IPDM	Selector lever in any position other than P and N	Off
	Selector lever in P or N position	On

BCM (BODY CONTROL MODULE)

< ECU DIAGNOSIS INFORMATION >

Monitor Item	Condition	Value/Status	
SFT P -MET	Selector lever in any position other than P	Off	A
	Selector lever in P position	On	
SFT N -MET	Selector lever in any position other than N	Off	B
	Selector lever in N position	On	
ENGINE STATE	Engine stopped	Stop	
	While the engine stalls	Stall	C
	At engine cranking	Crank	
	Engine running	Run	D
S/L LOCK-IPDM	Steering is locked	Off	
	Steering is unlocked	On	E
S/L UNLK-IPDM	Steering is unlocked	Off	
	Steering is locked	On	F
S/L RELAY-REQ	Steering is unlocked	Off	
	Steering is locked	On	
VEH SPEED 1	While driving	Equivalent to speedometer reading	G
VEH SPEED 2	While driving	Equivalent to speedometer reading	
DOOR STAT-DR	Driver door is locked	LOCK	H
	Wait with selective UNLOCK operation (5 seconds)	READY	
	Driver door is unlocked	UNLOCK	I
DOOR STAT-AS	Passenger door is locked	LOCK	
	Wait with selective UNLOCK operation (5 seconds)	READY	J
	Passenger door is unlocked	UNLOCK	
ID OK FLAG	Steering is locked	Reset	
	Steering is unlocked	Set	K
PRMT ENG STRT	The engine start is prohibited	Reset	
	The engine start is permitted	Set	
PRMT RKE STRT	NOTE: The item is indicated, but not monitored.	Reset	DEF
RKE OPE COUN1	During the operation of the key	Operation frequency of the key	
RKE OPE COUN2	NOTE: The item is indicated, but not monitored.	—	M
CONFIRM ID ALL	The key ID that the key slot receives is not recognized by any key ID registered to BCM.	Yet	N
	The key ID that the key slot receives is recognized by any key ID registered to BCM.	Done	
CONFIRM ID4	The key ID that the key slot receives is not recognized by the fourth key ID registered to BCM.	Yet	O
	The key ID that the key slot receives is recognized by the fourth key ID registered to BCM.	Done	P
CONFIRM ID3	The key ID that the key slot receives is not recognized by the third key ID registered to BCM.	Yet	
	The key ID that the key slot receives is recognized by the third key ID registered to BCM.	Done	

BCM (BODY CONTROL MODULE)

< ECU DIAGNOSIS INFORMATION >

Monitor Item	Condition	Value/Status
CONFIRM ID2	The key ID that the key slot receives is not recognized by the second key ID registered to BCM.	Yet
	The key ID that the key slot receives is recognized by the second key ID registered to BCM.	Done
CONFIRM ID1	The key ID that the key slot receives is not recognized by the first key ID registered to BCM.	Yet
	The key ID that the key slot receives is recognized by the first key ID registered to BCM.	Done
NOT REGISTERED	BCM detects registered key ID, or BCM does not detect key ID.	ID OK
	BCM detects non-registration key ID.	ID NG
TP 4	The ID of fourth key is not registered to BCM	Yet
	The ID of fourth key is registered to BCM	Done
TP 3	The ID of third key is not registered to BCM	Yet
	The ID of third key is registered to BCM	Done
TP 2	The ID of second key is not registered to BCM	Yet
	The ID of second key is registered to BCM	Done
TP 1	The ID of first key is not registered to BCM	Yet
	The ID of first key is registered to BCM	Done
AIR PRESS FL	Ignition switch ON (Only when the signal from the transmitter is received)	Air pressure of front LH tire
AIR PRESS FR	Ignition switch ON (Only when the signal from the transmitter is received)	Air pressure of front RH tire
AIR PRESS RR	Ignition switch ON (Only when the signal from the transmitter is received)	Air pressure of rear RH tire
AIR PRESS RL	Ignition switch ON (Only when the signal from the transmitter is received)	Air pressure of rear LH tire
ID REGST FL1	ID of front LH tire transmitter is registered	Done
	ID of front LH tire transmitter is not registered	Yet
ID REGST FR1	ID of front RH tire transmitter is registered	Done
	ID of front RH tire transmitter is not registered	Yet
ID REGST RR1	ID of rear RH tire transmitter is registered	Done
	ID of rear RH tire transmitter is not registered	Yet
ID REGST RL1	ID of rear LH tire transmitter is registered	Done
	ID of rear LH tire transmitter is not registered	Yet
WARNING LAMP	Tire pressure indicator OFF	Off
	Tire pressure indicator ON	On
BUZZER	Tire pressure warning alarm is not sounding	Off
	Tire pressure warning alarm is sounding	On

BCM (BODY CONTROL MODULE)

< ECU DIAGNOSIS INFORMATION >

TERMINAL LAYOUT

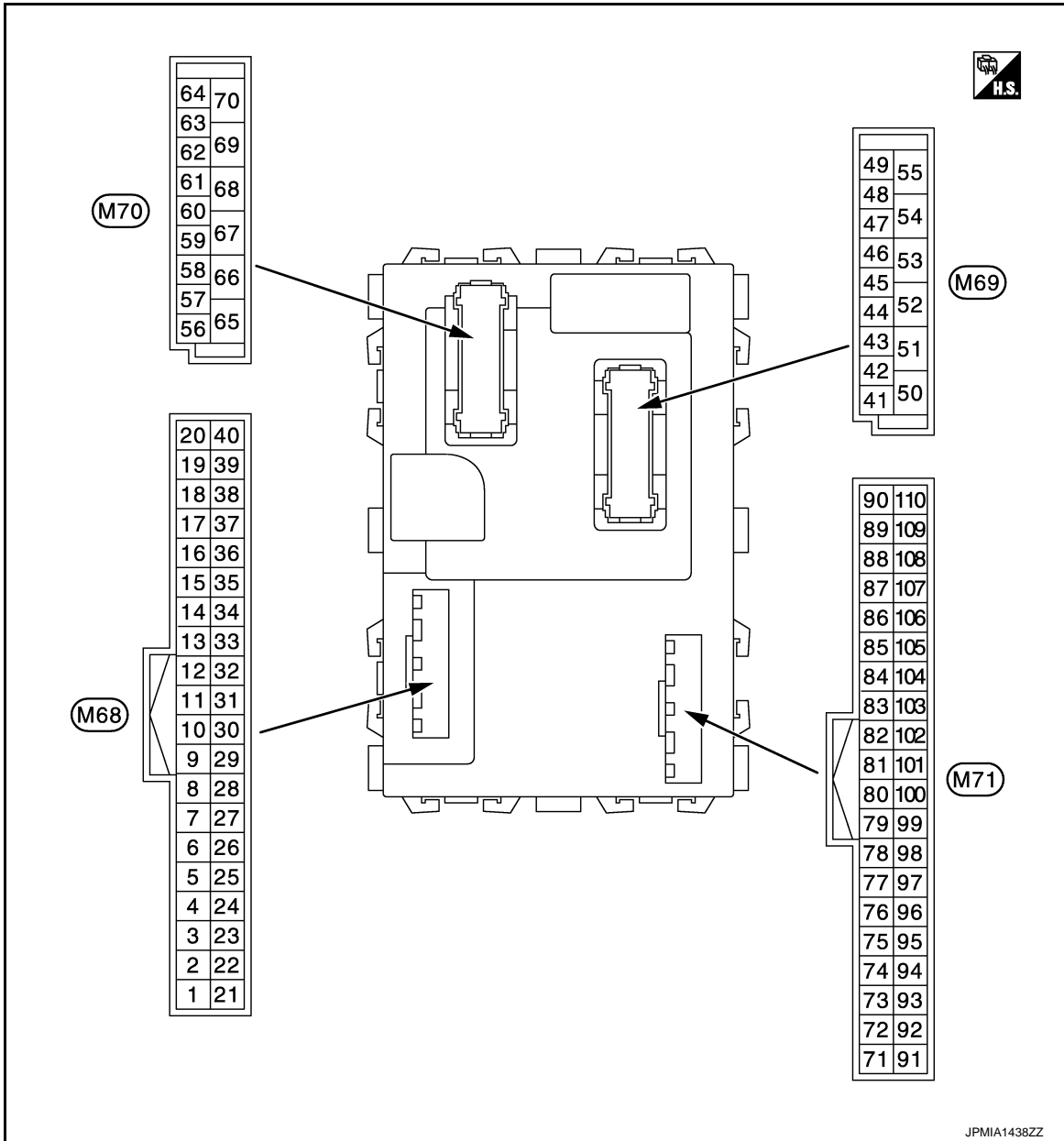

NOTE:

- Connector color
- M68, M70: Black
- M69, M71: White

PHYSICAL VALUES

A
B
C
D
E
F
G
H
I
J
K

DEF

M
N
O
P

BCM (BODY CONTROL MODULE)

< ECU DIAGNOSIS INFORMATION >

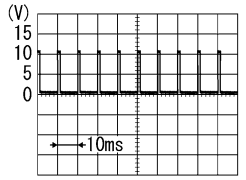
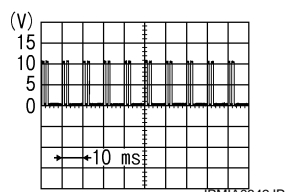
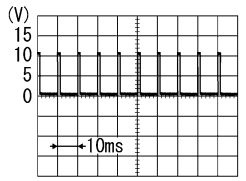
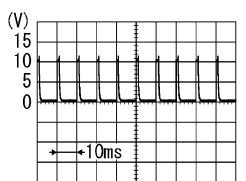
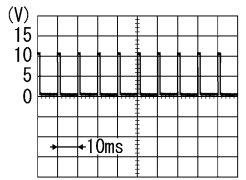
Terminal No. (Wire color)		Description		Condition	Value (Approx.)		
+	-	Signal name	Input/ Output				
2 (BR/W)	Ground	Combination switch INPUT 5	Input	Combination switch (Wiper intermit- tent dial 4)	All switch OFF	0 V	
					Turn signal switch RH		
					Lighting switch HI		
					Lighting switch 1ST		1.0 V
					Lighting switch 2ND		
3 (GR)	Ground	Combination switch INPUT 4	Input	Combination switch (Wiper intermit- tent dial 4)	All switch OFF	0 V	
					Turn signal switch LH		
					Lighting switch PASS		
					Lighting switch 2ND		1.0 V
					Front fog lamp switch ON		
4 (L/Y)	Ground	Combination switch INPUT 3	Input	Combination switch (Wiper intermit- tent dial 4)	All switch OFF	0 V	
					Front wiper switch LO		
					Front wiper switch MIST		
					Front wiper switch INT		
					Lighting switch AUTO		1.0 V

BCM (BODY CONTROL MODULE)

< ECU DIAGNOSIS INFORMATION >

Terminal No. (Wire color)		Description		Condition	Value (Approx.)	
+	-	Signal name	Input/ Output			
5 (G)	Ground	Combination switch INPUT 2	Input	Combination switch	All switch OFF (Wiper intermittent dial 4)	0 V
					Front washer switch (Wiper intermittent dial 4)	
					Rear washer ON (Wiper intermittent dial 4)	
					Any of the condition below with all switch OFF <ul style="list-style-type: none"> • Wiper intermittent dial 1 • Wiper intermittent dial 5 • Wiper intermittent dial 6 	
Rear wiper switch ON (Wiper intermittent dial 4)		0.8 V				
6 (L/R)	Ground	Combination switch INPUT 1	Input	Combination switch	All switch OFF (Wiper intermittent dial 4)	0 V
					Front wiper switch HI (Wiper intermittent dial 4)	
					Rear wiper switch INT (Wiper intermittent dial 4)	
					Wiper intermittent dial 3 (All switch OFF)	
					Any of the condition below with all switch OFF <ul style="list-style-type: none"> • Wiper intermittent dial 1 • Wiper intermittent dial 2 	
Any of the condition below with all switch OFF <ul style="list-style-type: none"> • Wiper intermittent dial 6 • Wiper intermittent dial 7 		0.8 V				

A
B
C
D
E
F
G
H
I
J
K
DEF
M
N
O
P

BCM (BODY CONTROL MODULE)

< ECU DIAGNOSIS INFORMATION >

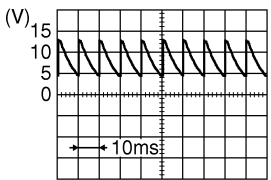
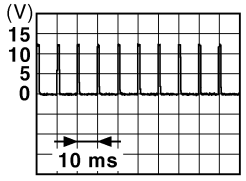
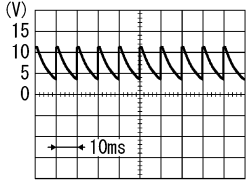
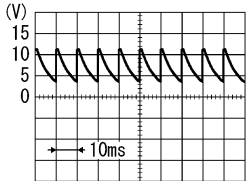
Terminal No. (Wire color)		Description		Condition		Value (Approx.)
+	-	Signal name	Input/ Output			
7 (W/R)	Ground	Door key cylinder switch UNLOCK	Input	Door key cylin- der switch	NEUTRAL position	 <small>JPMIA0587GB</small> 8.0 - 8.5 V
					UNLOCK position	0 V
8 (W/B)	Ground	Door key cylinder switch LOCK	Input	Door key cylin- der switch	NEUTRAL position	12 V
					LOCK position	0 V
9 (R)	Ground	Stop lamp switch 1	Input	Stop lamp switch	OFF (Brake pedal is not depressed)	0 V
					ON (Brake pedal is de- pressed)	Battery voltage
10 (V/W)	Ground	Tire pressure warn- ing check switch	Input	Ignition switch OFF	 <small>JPMIA0012GB</small> 1.0 - 1.5 V	
					0 V	
11 (L/Y)	Ground	ACC feedback	Input	Ignition switch OFF	0 V	
				Ignition switch ACC or ON	Battery voltage	
12 (SB)	Ground	Passenger door switch	Input	Passenger door switch	 <small>PKIB4960J</small> 7.0 - 8.0 V	
					ON (When passenger door opened)	0 V
13 (GR/L)	Ground	Rear RH door switch	Input	Rear RH door switch	 <small>PKIB4960J</small> 7.0 - 8.0 V	
					ON (When rear RH door opened)	0 V
14 (L/B)	Ground	Optical sensor	Input	Ignition switch ON	When bright outside of the vehicle	Close to 5 V
					When dark outside of the vehicle	Close to 0 V

BCM (BODY CONTROL MODULE)

< ECU DIAGNOSIS INFORMATION >

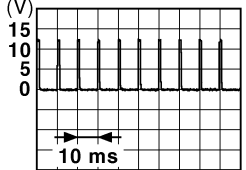
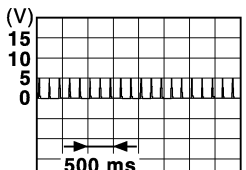
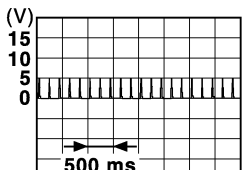
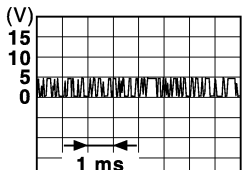
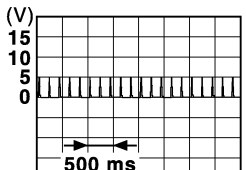
Terminal No. (Wire color)		Description		Condition		Value (Approx.)
+	-	Signal name	Input/ Output			
15 (W/L)	Ground	Rear window defogger switch	Input	Rear window defogger switch	Not pressed	 <small>JPMIA0012GB</small> 1.0 - 1.5 V
				Rear window defogger switch	Pressed	0 V
17 (R/G)	Ground	Optical sensor power supply	Output	Ignition switch	OFF, ACC	0 V
					ON	5 V
18 (V)	Ground	Receiver and sensor ground	Input	Ignition switch ON		0 V
19 (BR)	Ground	Remote keyless entry receiver power supply	Output	Ignition switch OFF		 <small>JMKIA3838GB</small>
20 (G/Y)	Ground	Remote keyless entry receiver communication	Input	Waiting		 <small>JMKIA3838GB</small>
				Signal receiving		 <small>JMKIA3841GB</small>
21 (P/L)	Ground	NATS antenna amp.	Input/ Output	During waiting	Ignition switch is pressed while inserting the key into the key slot.	Just after pressing ignition switch. Pointer of tester should move.
22 (W/G)	Ground	Remote keyless entry receiver RSSI	Input	Waiting		0 V
				Signal receiving		 <small>JMKIA3838GB</small>

A
B
C
D
E
F
G
H
I
J
K
DEF
M
N
O
P

BCM (BODY CONTROL MODULE)

< ECU DIAGNOSIS INFORMATION >

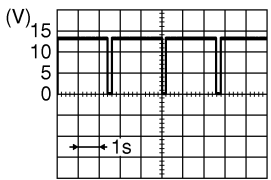
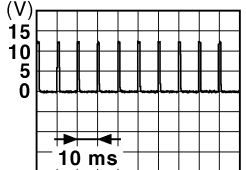
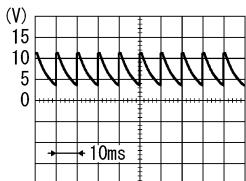
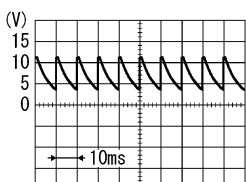
Terminal No. (Wire color)		Description		Condition	Value (Approx.)		
+	-	Signal name	Input/ Output				
23 (R/Y)	Ground	Security indicator lamp	Output	Security indicator	ON	0 V	
				Blinking (Ignition switch OFF)	 <p style="text-align: center;">12.0 V</p>		
				OFF	Battery voltage		
24* (GR/R)	Ground	Dongle link	Input/ Output	Ignition switch OFF		5 V	
25 (LG)	Ground	NATS antenna amp.	Input/ Output	During waiting	Ignition switch is pressed while inserting the key into the key slot.	Just after pressing ignition switch. Pointer of tester should move.	
27 (Y/G)	Ground	A/C switch	Input	Air conditioner	OFF (A/C switch indicator: OFF)	 <p style="text-align: center;">1.0 - 1.5 V</p>	
				ON (A/C switch indicator: ON)	0 V		
28 (G/W)	Ground	Blower fan switch	Input	Blower fan	OFF	0 V	
				ON	 <p style="text-align: center;">7.0 - 8.0 V</p>		
29 (L/W)	Ground	Hazard switch	Input	Hazard switch	OFF	12 V	
				ON	0 V		
31 (G/B)	Ground	Front door lock assembly driver side (Unlock sensor)	Input	Driver door	LOCK status (Unlock sensor switch OFF)	 <p style="text-align: center;">7.0 - 8.0 V</p>	
				UNLOCK status (Unlock sensor switch ON)	0 V		

BCM (BODY CONTROL MODULE)

< ECU DIAGNOSIS INFORMATION >

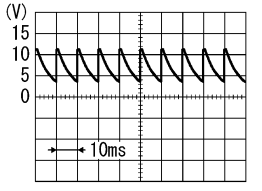
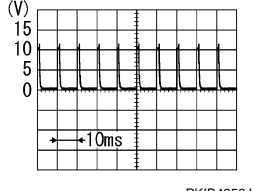
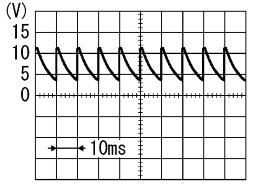
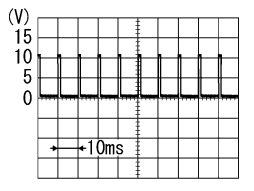
Terminal No. (Wire color)		Description		Condition	Value (Approx.)
+	-	Signal name	Input/ Output		
32 (LG)	Ground	Combination switch OUTPUT 5	Output	Combination switch	All switch OFF (Wiper intermittent dial 4)
					Front fog lamp switch ON (Wiper intermittent dial 4)
					Rear wiper switch ON (Wiper intermittent dial 4)
					Any of the condition below with all switch OFF <ul style="list-style-type: none"> • Wiper intermittent dial 1 • Wiper intermittent dial 2 • Wiper intermittent dial 6 • Wiper intermittent dial 7
					 <p style="text-align: center;">7.0 - 8.0 V</p>
					 <p style="text-align: center;">1.0 V</p>
33 (Y/L)	Ground	Combination switch OUTPUT 4	Output	Combination switch	All switch OFF (Wiper intermittent dial 4)
					Lighting switch 1ST (Wiper intermittent dial 4)
					Lighting switch AUTO (Wiper intermittent dial 4)
					Rear wiper switch INT (Wiper intermittent dial 4)
					 <p style="text-align: center;">7.0 - 8.0 V</p>
					 <p style="text-align: center;">1.2 V</p>

A
B
C
D
E
F
G
H
I
J
K
DEF
M
N
O
P

BCM (BODY CONTROL MODULE)

< ECU DIAGNOSIS INFORMATION >

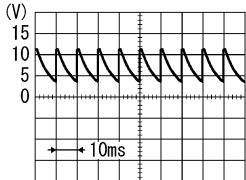
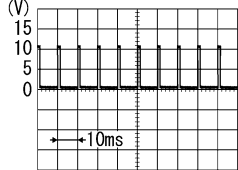
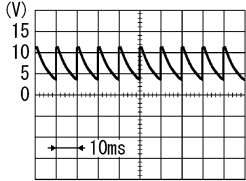
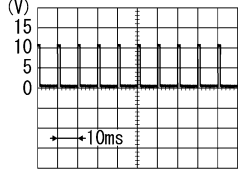
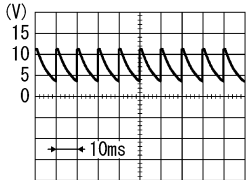
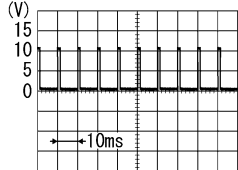
Terminal No. (Wire color)		Description		Condition	Value (Approx.)	
+	-	Signal name	Input/ Output			
34 (W)	Ground	Combination switch OUTPUT 3	Output	Combination switch	All switch OFF (Wiper intermittent dial 4)	 <p style="text-align: right;">PKIB4960J</p> <p style="text-align: center;">7.0 - 8.0 V</p>
					Lighting switch 2ND (Wiper intermittent dial 4)	 <p style="text-align: right;">PKIB4958J</p> <p style="text-align: center;">1.2 V</p>
					Lighting switch HI (Wiper intermittent dial 4)	
					Rear washer switch ON (Wiper intermittent dial 4)	
Any of the condition below with all switch OFF						
<ul style="list-style-type: none"> • Wiper intermittent dial 1 • Wiper intermittent dial 2 • Wiper intermittent dial 3 						
35 (R/L)	Ground	Combination switch OUTPUT 2	Output	Combination switch (Wiper intermit- tent dial 4)	All switch OFF	 <p style="text-align: right;">PKIB4960J</p> <p style="text-align: center;">7.0 - 8.0 V</p>
					Lighting switch 2ND	 <p style="text-align: right;">PKIB4958J</p> <p style="text-align: center;">1.2 V</p>
					Lighting switch PASS	
					Front wiper switch INT	
Front wiper switch HI						
36 (L/O)	Ground	Combination switch OUTPUT 1	Output	Combination switch (Wiper intermit- tent dial 4)	All switch OFF	 <p style="text-align: right;">PKIB4960J</p> <p style="text-align: center;">7.0 - 8.0 V</p>
					Turn signal switch RH	 <p style="text-align: right;">PKIB4958J</p> <p style="text-align: center;">1.2 V</p>
					Turn signal switch LH	
					Front wiper switch LO (Front wiper switch MIST)	
Front washer switch ON						

BCM (BODY CONTROL MODULE)

< ECU DIAGNOSIS INFORMATION >

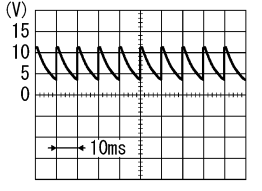
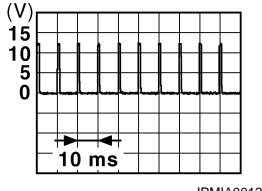
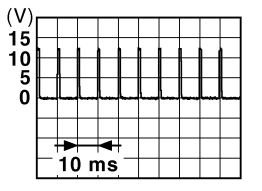
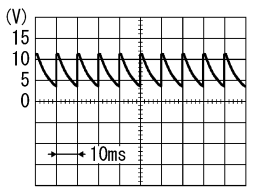
Terminal No. (Wire color)		Description		Condition	Value (Approx.)	
		Signal name	Input/ Output			
+	-					
37 (G/O)	Ground	Selector lever P position switch	Input	Selector lever	P position	0 V
					Any position other than P	12 V
38 (O)	Ground	IGN feedback	Input	Ignition switch	OFF or ACC	0 V
					ON	Battery voltage
39 (L)	Ground	CAN-H	Input/ Output	—	—	
40 (P)	Ground	CAN-L	Input/ Output	—	—	
43 (W)	Ground	Back door switch	Input	Back door switch	OFF (When back door closed)	 PKIB4960J 9.5 - 10.0 V
					ON (When back door opened)	0 V
44 (LG)	Ground	Rear wiper stop position	Input	Ignition switch ON	Rear wiper stop position	12 V
					Any position other than rear wiper stop position	0 V
45 (GR)	Ground	Door lock and unlock switch LOCK	Input	Door lock and unlock switch	NEUTRAL position	 JPMA0012GB 1.0 - 1.5 V
					LOCK position	0 V
46 (BR)	Ground	Door lock and unlock switch UNLOCK	Input	Door lock and unlock switch	NEUTRAL position	 JPMA0012GB 1.0 - 1.5 V
					UNLOCK position	0 V
47 (BR/Y)	Ground	Driver door switch	Input	Driver door switch	OFF (When driver door closed)	 PKIB4960J 7.0 - 8.0 V
					ON (When driver door opened)	0 V

A
B
C
D
E
F
G
H
I
J
K
DEF
M
N
O
P

BCM (BODY CONTROL MODULE)

< ECU DIAGNOSIS INFORMATION >

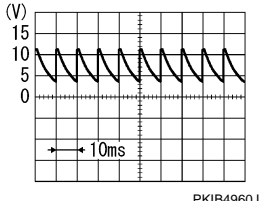
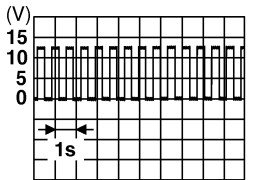
Terminal No. (Wire color)		Description		Condition		Value (Approx.)
+	-	Signal name	Input/ Output			
48 (W/G)	Ground	Rear LH door switch	Input	Rear LH door switch	OFF (When rear LH door closed)	 7.0 - 8.0 V
					ON (When rear door LH opened)	0 V
49 (Y)	Ground	Luggage room lamp	Output	Luggage room lamp switch DOOR position	Back door is closed (Back door lamp turns OFF)	12 V
					Back door is opened (Back door lamp turns ON)	0 V
54 (L/W)	Ground	Rear wiper	Output	Rear wiper	OFF (Stopped)	0 V
					ON (Activated)	12 V
55 (G)	Ground	Rear door UNLOCK	Output	Rear door	UNLOCK (Actuator is activated)	12 V
					Other than UNLOCK (Actuator is not activated)	0 V
56 (L)	Ground	Interior room lamp power supply	Output		Interior room lamp battery saver is activated. (Cuts the interior room lamp power supply)	0 V
					Interior room lamp battery saver is not activated. (Outputs the interior room lamp power supply)	12 V
57 (Y)	Ground	Battery power supply	Input	Ignition switch OFF		Battery voltage
59 (G)	Ground	Passenger door UNLOCK	Output	Passenger door	UNLOCK (Actuator is activated)	12 V
					Other than UNLOCK (Actuator is not activated)	0 V
60 (W/B)	Ground	Turn signal LH	Output	Ignition switch ON	Turn signal switch OFF	0 V
					Turn signal switch LH	 6.0 V

BCM (BODY CONTROL MODULE)

< ECU DIAGNOSIS INFORMATION >

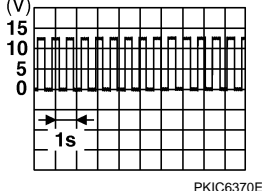
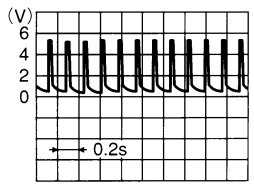
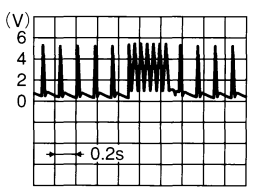
Terminal No. (Wire color)		Description		Condition	Value (Approx.)	
+	-	Signal name	Input/ Output			
61 (W/L)	Ground	Turn signal RH	Output	Ignition switch OFF	0 V	
				Ignition switch ON	Turn signal switch RH	 6.0 V
63 (BR)	Ground	Interior room lamp timer control	Output	Interior room lamp OFF	12 V	
				Interior room lamp ON	0 V	
65 (V)	Ground	All doors LOCK	Output	All doors LOCK (Actuator is activated)	12 V	
				All doors Other than LOCK (Actuator is not activated)	0 V	
66 (L/B)	Ground	Driver door UN-LOCK	Output	Driver door UNLOCK (Actuator is activated)	12 V	
				Driver door Other than UNLOCK (Actuator is not activated)	0 V	
67 (B)	Ground	Ground	Output	Ignition switch ON	0 V	
68 (L)	Ground	P/W power supply (IGN)	Output	Ignition switch ON	12 V	
69 (L/W)	Ground	P/W power supply (BAT)	Output	Ignition switch OFF	12 V	
70 (Y)	Ground	Battery power supply	Input	Ignition switch OFF	Battery voltage	
71 (R)	Ground	Tire pressure receiver communication	Input/ Output	Ignition switch ON	Standby state	 OCC3881D
				Ignition switch ON	When receiving the signal from the transmitter	 OCC3880D
72 (R/W)	Ground	Back door lock actuator relay control	Output	Back door LOCK (Actuator is activated)	0 V	
				Back door Other than LOCK (Actuator is not activated)	Battery voltage	
75 (SB)	Ground	Driver door request switch	Input	Driver door request switch ON (Pressed)	0 V	
				Driver door request switch OFF (Not pressed)	12 V	

A
B
C
D
E
F
G
H
I
J
K
DEF
M
N
O
P

BCM (BODY CONTROL MODULE)

< ECU DIAGNOSIS INFORMATION >

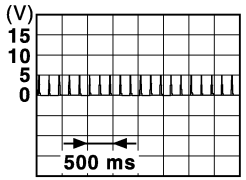
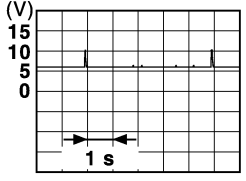
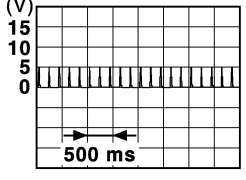
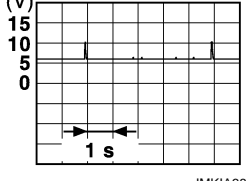
Terminal No. (Wire color)		Description		Condition		Value (Approx.)
+	-	Signal name	Input/ Output			
76 (G)	Ground	Passenger door re- quest switch	Input	Passenger door re- quest switch	ON (Pressed)	0 V
					OFF (Not pressed)	12 V
77 (W)	Ground	Back door request switch	Input	Back door re- quest switch	ON (Pressed)	0 V
					OFF (Not pressed)	12 V
78 (LG)	Ground	Driver door antenna (+)	Output	When the driver door request switch is operat- ed with ignition switch OFF	When Intelligent Key is not in the antenna detec- tion area	 <small>JMKIA3838GB</small>
					When Intelligent Key is in the antenna detection area	 <small>JMKIA3839GB</small>
79 (V)	Ground	Driver door antenna (-)	Output	When the driver door request switch is operat- ed with ignition switch OFF	When Intelligent Key is not in the antenna detec- tion area	 <small>JMKIA3838GB</small>
					When Intelligent Key is in the antenna detection area	 <small>JMKIA3839GB</small>

BCM (BODY CONTROL MODULE)

< ECU DIAGNOSIS INFORMATION >

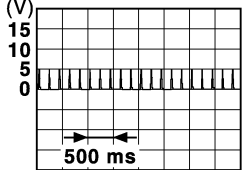
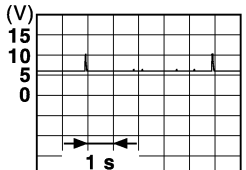
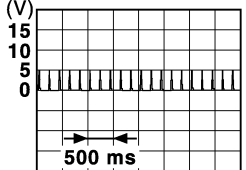
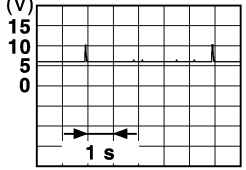
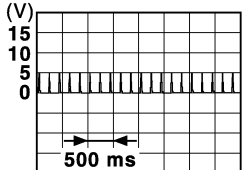
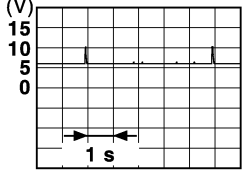
Terminal No. (Wire color)		Description		Condition	Value (Approx.)
+	-	Signal name	Input/ Output		
80 (BR/Y)	Ground	Passenger door antenna (+)	Output	When Intelligent Key is not in the antenna detection area	 <p style="text-align: right; font-size: small;">JMkia3838GB</p>
				When the passenger door request switch is operated with ignition switch OFF	 <p style="text-align: right; font-size: small;">JMkia3839GB</p>
81 (L/Y)	Ground	Passenger door antenna (-)	Output	When Intelligent Key is not in the antenna detection area	 <p style="text-align: right; font-size: small;">JMkia3838GB</p>
				When the passenger door request switch is operated with ignition switch OFF	 <p style="text-align: right; font-size: small;">JMkia3839GB</p>
82 (W/B)	Ground	Back door antenna (+)	Output	When Intelligent Key is not in the antenna detection area	 <p style="text-align: right; font-size: small;">JMkia3838GB</p>
				When the back door request switch is operated with ignition switch OFF	 <p style="text-align: right; font-size: small;">JMkia3839GB</p>

A
B
C
D
E
F
G
H
I
J
K
DEF
M
N
O
P

BCM (BODY CONTROL MODULE)

< ECU DIAGNOSIS INFORMATION >

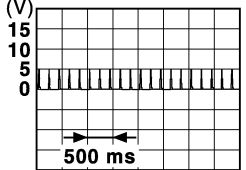
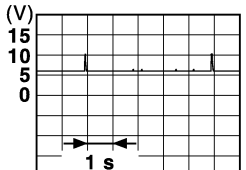
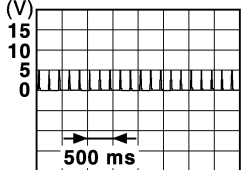
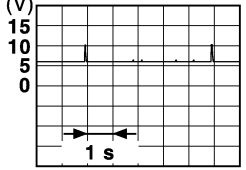
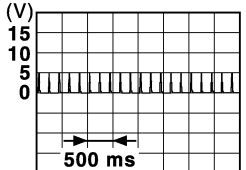
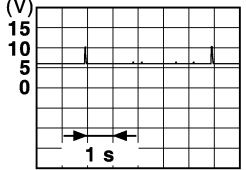
Terminal No. (Wire color)		Description		Condition	Value (Approx.)
+	-	Signal name	Input/ Output		
83 (B/W)	Ground	Back door antenna (-)	Output	When the back door request switch is operated with ignition switch OFF	 <p style="text-align: right; font-size: small;">JMkia3838GB</p>
				When Intelligent Key is in the antenna detection area	 <p style="text-align: right; font-size: small;">JMkia3839GB</p>
84 (Y/G)	Ground	Room antenna (+) (Instrument panel)	Output	Ignition switch OFF	 <p style="text-align: right; font-size: small;">JMkia3838GB</p>
				When Intelligent Key is in the antenna detection area	 <p style="text-align: right; font-size: small;">JMkia3839GB</p>
85 (Y/L)	Ground	Room antenna (-) (Instrument panel)	Output	Ignition switch OFF	 <p style="text-align: right; font-size: small;">JMkia3838GB</p>
				When Intelligent Key is in the antenna detection area	 <p style="text-align: right; font-size: small;">JMkia3839GB</p>

BCM (BODY CONTROL MODULE)

< ECU DIAGNOSIS INFORMATION >

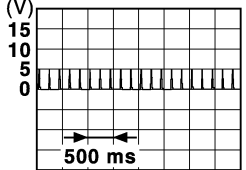
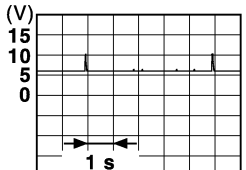
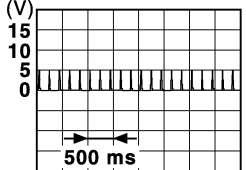
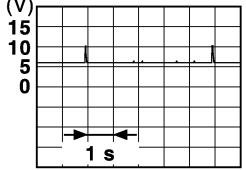
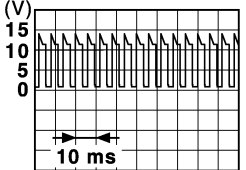
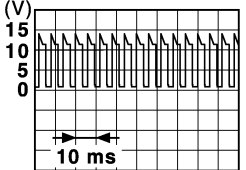
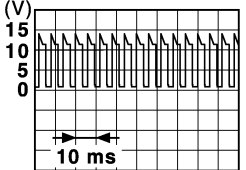
Terminal No. (Wire color)		Description		Condition	Value (Approx.)				
+	-	Signal name	Input/ Output						
86 (P)	Ground	Luggage room antenna (+)	Output	Ignition switch OFF	 <p style="text-align: right; font-size: small;">JMkia3838GB</p>				
				When Intelligent Key is in the antenna detection area	 <p style="text-align: right; font-size: small;">JMkia3839GB</p>				
87 (L)	Ground	Luggage room antenna (-)	Output	Ignition switch OFF	 <p style="text-align: right; font-size: small;">JMkia3838GB</p>				
				When Intelligent Key is in the antenna detection area	 <p style="text-align: right; font-size: small;">JMkia3839GB</p>				
90 (W/L)	Ground	Push-button ignition switch illumination	Output	Push-button ignition switch illumination	<table border="0" style="width: 100%;"> <tr> <td style="width: 50%;">ON</td> <td style="text-align: center;">12 V</td> </tr> <tr> <td style="width: 50%;">OFF</td> <td style="text-align: center;">0 V</td> </tr> </table>	ON	12 V	OFF	0 V
ON	12 V								
OFF	0 V								
91 (Y)	Ground	ACC/ON indicator lamp	Output	Ignition switch	<table border="0" style="width: 100%;"> <tr> <td style="width: 50%;">OFF</td> <td style="text-align: center;">Battery voltage</td> </tr> <tr> <td style="width: 50%;">ACC or ON</td> <td style="text-align: center;">0.5 V</td> </tr> </table>	OFF	Battery voltage	ACC or ON	0.5 V
OFF	Battery voltage								
ACC or ON	0.5 V								
92 (BR/R)	Ground	Push-button ignition switch illumination ground	Output	Tail lamp	<table border="0" style="width: 100%;"> <tr> <td style="width: 50%;">OFF</td> <td style="text-align: center;">0 V</td> </tr> <tr> <td style="width: 50%;">ON</td> <td style="text-align: center;"> <p>NOTE: When the illumination brightening/dimming level is in the neutral position</p>  <p style="text-align: right; font-size: small;">JPMIA1554GB</p> </td> </tr> </table>	OFF	0 V	ON	<p>NOTE: When the illumination brightening/dimming level is in the neutral position</p>  <p style="text-align: right; font-size: small;">JPMIA1554GB</p>
OFF	0 V								
ON	<p>NOTE: When the illumination brightening/dimming level is in the neutral position</p>  <p style="text-align: right; font-size: small;">JPMIA1554GB</p>								

A
B
C
D
E
F
G
H
I
J
K
DEF
M
N
O
P

BCM (BODY CONTROL MODULE)

< ECU DIAGNOSIS INFORMATION >

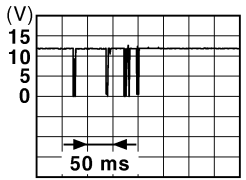
Terminal No. (Wire color)		Description		Condition		Value (Approx.)
		Signal name	Input/ Output			
+	-					
93 (GR/W)	Ground	Intelligent Key warn- ing buzzer	Output	Intelligent Key warning buzzer	Sounding	0 V
					Not sounding	12 V
94 (Y/R)	Ground	Steering lock unit communication	Input/ Output	Steering lock	LOCK status	12 V
					LOCK or UNLOCK	
					For 15 seconds after UN- LOCK	12 V
					15 seconds or later after UNLOCK	0 V
JMkia0066GB						
95 (W/G)	Ground	Steering lock unit power supply	Output	Ignition switch	OFF or ACC	12 V
					ON	0 V
96 (BR/W)	Ground	ACC relay control	Output	Ignition switch	OFF	0 V
					ACC or ON	12 V
97 (L/R)	Ground	Starter relay control	Output	Ignition switch ON	When selector lever is in P or N position	Battery voltage
					When selector lever is not in P or N position	0 V
98 (BR)	Ground	Ignition relay (IPDM E/R) control	Output	Ignition switch	OFF or ACC	12 V
					ON	0 V
99 (W/R)	Ground	Ignition relay control	Output	Ignition switch	OFF or ACC	0 V
					ON	12 V
100 (L/O)	Ground	Push-button ignition switch (push switch)	Input	Push-button ig- nition switch (push switch)	Pressed	0 V
					Not pressed	12 V
102 (G)	Ground	Selector lever P/N position	Input	Selector lever	P or N position	Battery voltage
					Except P and N positions	0 V
104 (Y/R)	Ground	CVT shift selector (detention switch) power supply	Output	Ignition switch ON		12 V
105 (B/O)	Ground	Stop lamp switch 2	Input	Ignition switch OFF		Battery voltage
106 (Y/B)	Ground	Blower fan motor re- lay control	Output	Ignition switch	OFF or ACC	0 V
					ON	12 V
107 (L/W)	Ground	Steering lock condi- tion No. 1	Input	Steering lock	LOCK status	0 V
					UNLOCK status	12 V
108 (P/L)	Ground	Steering lock condi- tion No. 2	Input	Steering lock	LOCK status	12 V
					UNLOCK status	0 V
110 (BR/W)	Ground	Tire pressure receiv- er power supply	Output	Ignition switch	OFF or ACC	0 V
					ON	5 V

*: For Canada

BCM (BODY CONTROL MODULE)

< ECU DIAGNOSIS INFORMATION >

WITH INTELLIGENT KEY : Wiring Diagram - BCM -

INFOID:000000005133231

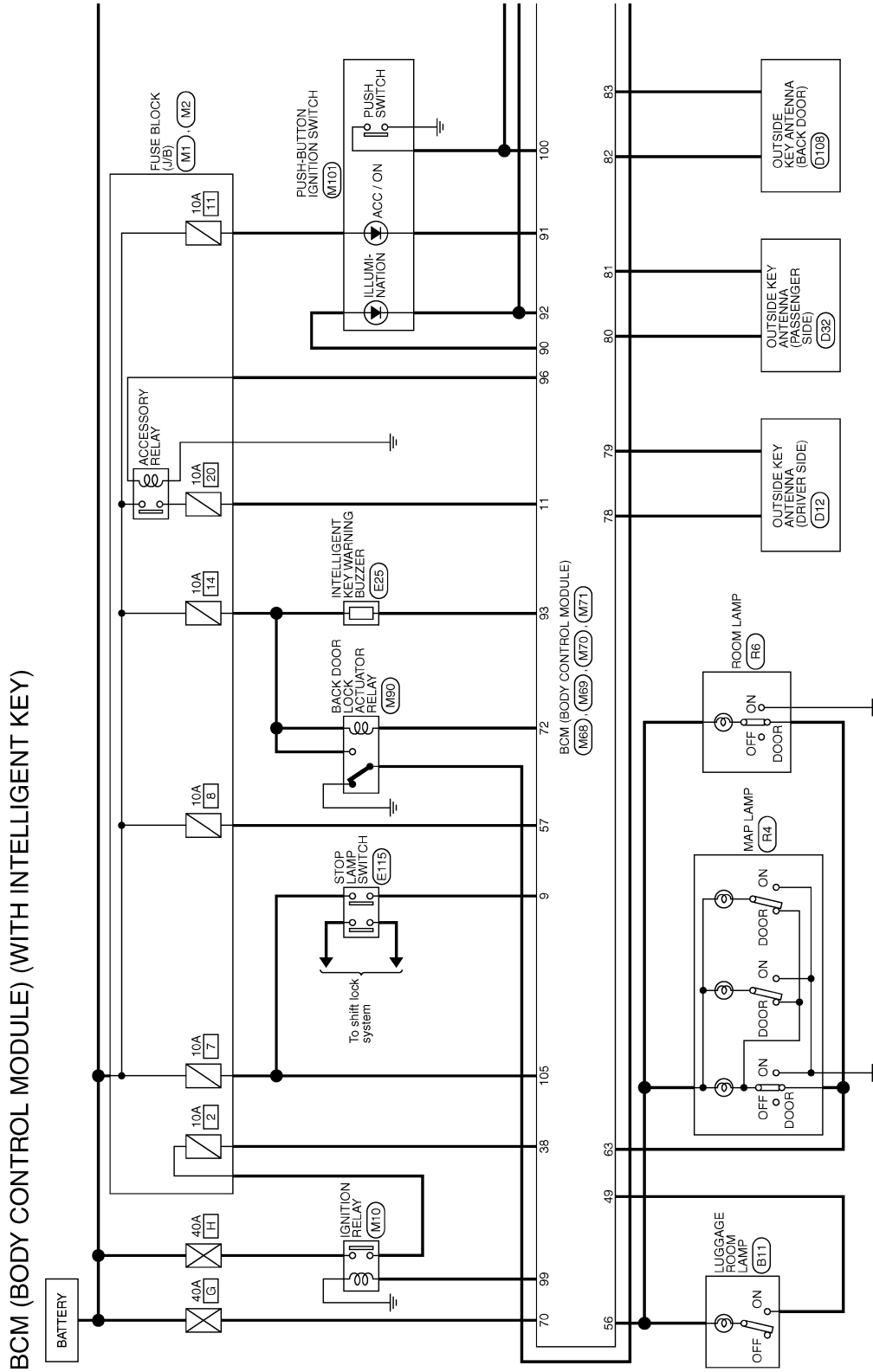

A
B
C
D
E
F
G
H
I
J
K
DEF
M
N
O
P

BCM (BODY CONTROL MODULE)

< ECU DIAGNOSIS INFORMATION >

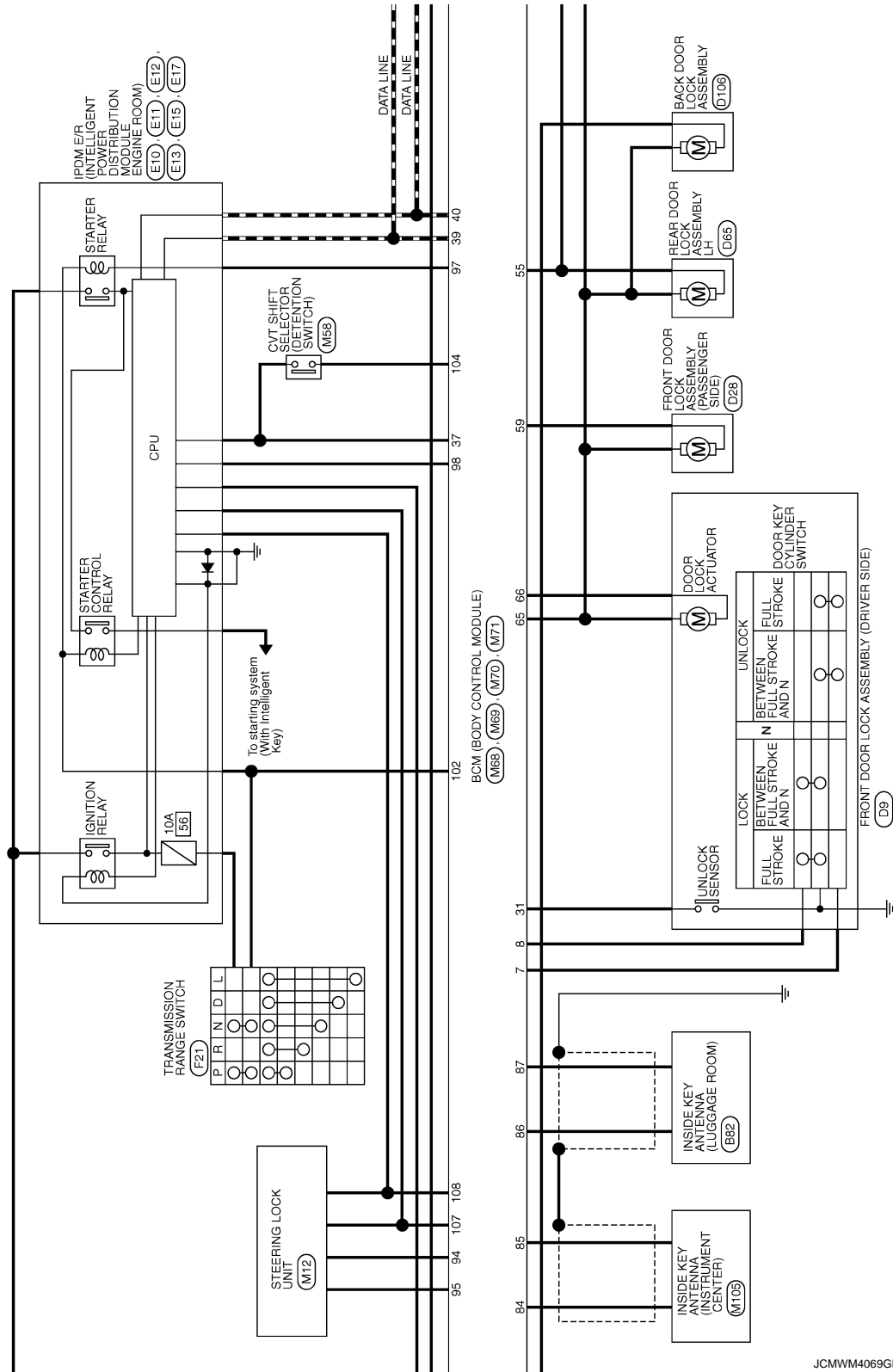

JCMWM4069GB

BCM (BODY CONTROL MODULE)

< ECU DIAGNOSIS INFORMATION >

For Canada

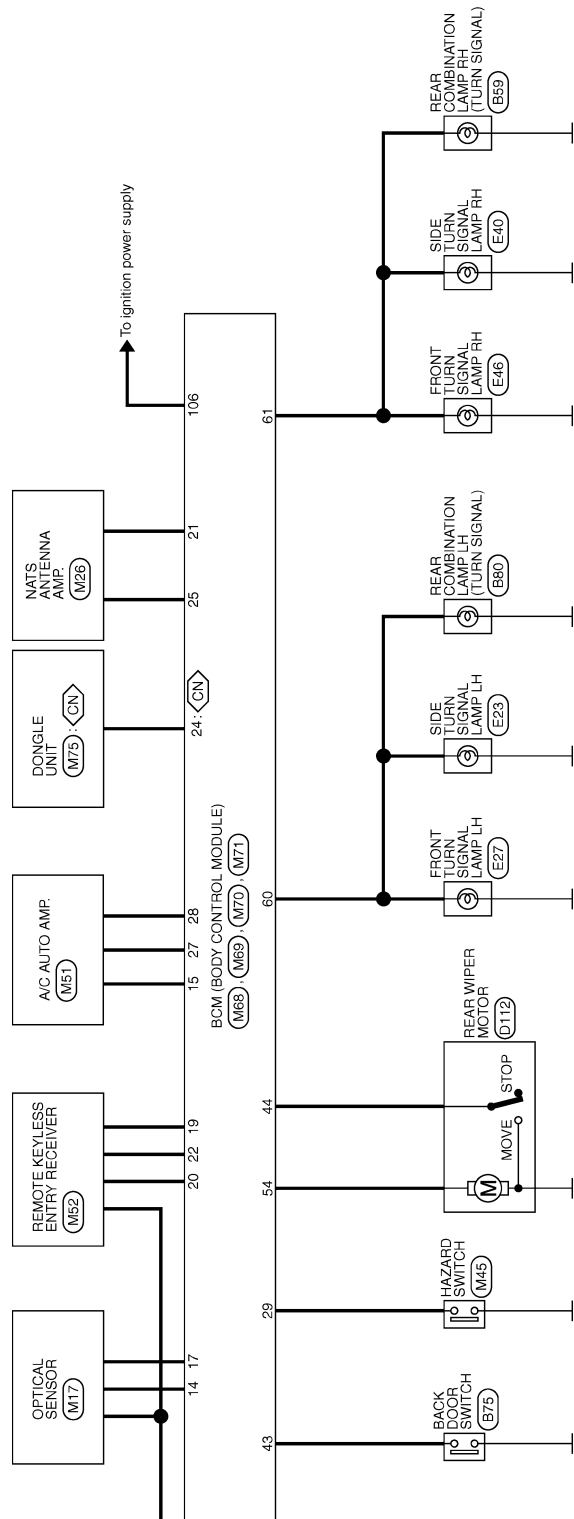

JCMWM4071GB

BCM (BODY CONTROL MODULE)

< ECU DIAGNOSIS INFORMATION >

BCM (BODY CONTROL MODULE) (WITH INTELLIGENT KEY)

Connector No.	M27
Connector Name	COMBINATION SWITCH
Connector Type	TH16FW-NH

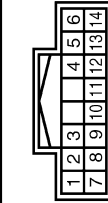

Connector No.	M68
Connector Name	BCM (BODY CONTROL MODULE) (WITH INTELLIGENT KEY)
Connector Type	TH4QFP-NH

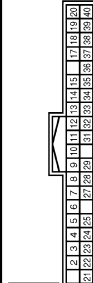

Terminal No.	Color of Wire	Signal Name [Specification]
2	GR	INPUT 4
5	L/Y	INPUT 3
7	W	OUTPUT 3
8	BR/W	INPUT 5
9	R/L	OUTPUT 2
10	Y/L	OUTPUT 4
11	L/O	OUTPUT 1
12	L/R	INPUT 1
13	LG	OUTPUT 5
14	G	INPUT 2

Terminal No.	Color of Wire	Signal Name [Specification]
2	BR/W	COMBI SW INPUT 5
3	GR	COMBI SW INPUT 4
4	L/Y	COMBI SW INPUT 3
5	G	COMBI SW INPUT 2
6	L/R	COMBI SW INPUT 1
7	W/R	KEY CYL UNLOCK SW
8	W/B	KEY CYL LOCK SW
9	R	STOP LAMP SW 1
10	V/W	TIRE PRESS WARNING CHECK SW
11	L/Y	ACC F/B
12	SB	PASSENGER DOOR SW

Connector No.	M70
Connector Name	BCM (BODY CONTROL MODULE) (WITH INTELLIGENT KEY)
Connector Type	FEA09FW-FHA6-SA

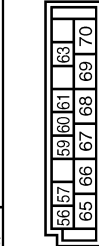

Terminal No.	Color of Wire	Signal Name [Specification]
56	L	INTERIOR ROOM LAMP POWER SUPPLY
57	Y	BAT (FUSE)
58	G	PASSENGER DOOR UNLOCK OUTPUT
60	W/B	TURN SIGNAL LH OUTPUT
61	W/L	TURN SIGNAL RH OUTPUT
63	BR	ROOM LAMP TIMER CONTROL
65	V	ALL DOOR LOCK OUTPUT
66	L/B	DRIVER DOOR UNLOCK OUTPUT
67	B	GND
68	L	POWER WINDOW POWER SUPPLY(GN)
69	L/W	POWER WINDOW POWER SUPPLY(BAT)

Terminal No.	Color of Wire	Signal Name [Specification]
13	GR/L	REAR RH DOOR SW
14	L/B	OPTICAL SENSOR
15	W/L	REAR WINDOW DEFROGGER SW
17	R/G	OPTICAL SENSOR POWER SUPPLY
18	V	RECEIVER SENSOR GND
19	BR	KEYLESS ENTRY RECEIVER POWER SUPPLY
20	G/Y	KEYLESS ENTRY RECEIVER COMM
21	P/L	NATS ANTENNA AMP
22	W/G	KEYLESS ENTRY RECEIVER RSSI
23	R/Y	SECURITY INDICATOR LAMP
24	GR/R	DOUBLE LINK
25	LG	NATS ANTENNA AMP
27	Y/G	A/C SW
28	G/W	BLOWER FAN SW
29	L/W	HAZARD SW
31	G/B	DR DOOR UNLOCK SENSOR
32	LG	COMBI SW OUTPUT 5
33	Y/L	COMBI SW OUTPUT 4
34	W	COMBI SW OUTPUT 3
35	R/L	COMBI SW OUTPUT 2
36	L/O	COMBI SW OUTPUT 1
37	G/O	SHIFT P
38	O	IGN F/B
39	L	CAN-H
40	P	CAN-L

Connector No.	M71
Connector Name	BCM (BODY CONTROL MODULE) (WITH INTELLIGENT KEY)
Connector Type	TH4QFP-NH

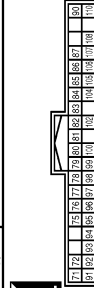

Terminal No.	Color of Wire	Signal Name [Specification]
71	R	TIRE PRESS RECEIVER COMM
72	R/W	BK DR LOCK ACT RELAY CONT
75	SB	DRIVER DOOR REQUEST SW
76	G	PASSENGER DOOR REQUEST SW
77	W	BACK DOOR REQUEST SW
78	LG	DRIVER DOOR ANT+
79	V	DRIVER DOOR ANT-
80	BR/Y	PASSENGER DOOR ANT-
81	L/Y	PASSENGER DOOR ANT+
82	W/B	BACK DOOR ANT-
83	B/W	BACK DOOR ANT+

Connector No.	M69
Connector Name	BCM (BODY CONTROL MODULE) (WITH INTELLIGENT KEY)
Connector Type	FEA09FW-FHA6-SA

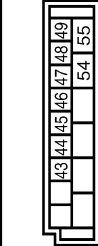

Terminal No.	Color of Wire	Signal Name [Specification]
43	W	BACK DOOR SW
44	LG	REAR WIPER STOP POSITION
45	GR	CENTRAL DOOR LOCK SW
46	BR	CENTRAL DOOR UNLOCK SW
47	BR/Y	DRIVER DOOR SW
48	W/G	REAR LH DOOR SW
49	Y	LUGGAGE ROOM LAMP OUTPUT
54	L/W	REAR WIPER OUTPUT
55	G	REAR DOOR UNLOCK OUTPUT

Terminal No.	Color of Wire	Signal Name [Specification]
84	Y/G	ROOM ANT-
85	Y/L	ROOM ANT+
86	P	LUGGAGE ROOM ANT-
87	L	LUGGAGE ROOM ANT+
90	W/L	PUSH-BUTTON IGNITION SW ILL POWER
91	Y	ACC/GN IND
92	BR/R	PUSH-BUTTON IGNITION SW ILL GND
93	GR/W	T-KEY WARN BUZZER
94	Y/R	S/L UNIT COMM
95	W/G	S/L UNIT POWER SUPPLY
96	BR/W	ACC RELAY CONT
97	L/R	STARTER RELAY CONT
98	BR	IGN RELAY (UP/DW E/R) CONT
99	W/R	IGN RELAY CONT
100	L/O	PUSH SW
102	G	SHIFT N/P
104	Y/R	CVT SHIFT SELECTOR POWER SUPPLY
105	B/O	STOP LAMP SW 2
106	Y/B	BLOWER FAN MOTOR RELAY CONT
107	L/W	S/L CONDITION 1
108	P/L	S/L CONDITION 2
110	BR/W	TIRE PRESS POWER SUPPLY

WITH INTELLIGENT KEY : Fail-safe

FAIL-SAFE CONTROL BY DTC
BCM performs fail-safe control when any DTC are detected.

A B C D E F G H I J K DEF M N O P

BCM (BODY CONTROL MODULE)

< ECU DIAGNOSIS INFORMATION >

Display contents of CONSULT	Fail-safe	Cancellation
B2013: ID DISCORD BCM-S/L	Inhibit engine cranking	When communication between BCM and steering lock unit are communicated normally.
B2014: CHAIN OF S/L-BCM	Inhibit engine cranking	When communication between BCM and steering lock unit are communicated normally.
B2192: ID DISCORD BCM-ECM	Inhibit engine cranking	Erase DTC
B2193: CHAIN OF BCM-ECM	Inhibit engine cranking	Erase DTC
B2195: ANTI-SCANNING	Inhibit engine cranking	Ignition switch ON → OFF
B2196: DONGLE NG	Inhibit engine cranking	Erase DTC
B2198: NATS ANTENNA AMP	Inhibit engine cranking	Erase DTC
B2557: VEHICLE SPEED	Inhibit steering lock	When the following CAN signal status (vehicle speed signal) becomes consistent <ul style="list-style-type: none"> • Vehicle speed signal (ABS) • Vehicle speed signal (Meter)
B2601: SHIFT POSITION	Inhibit steering lock	500 ms after the following signal reception status becomes consistent <ul style="list-style-type: none"> • Selector lever P position switch signal • P range signal (CAN)
B2602: SHIFT POSITION	Inhibit steering lock	5 seconds after the following BCM recognition conditions are fulfilled <ul style="list-style-type: none"> • Ignition switch is in the ON position • Selector lever P position switch signal: Except P position (battery voltage) • Vehicle speed: 4 km/h (2.5 MPH) or more
B2603: SHIFT POSI STATUS	Inhibit steering lock	500 ms after any of the following BCM recognition conditions are fulfilled <ul style="list-style-type: none"> • Status 1 <ul style="list-style-type: none"> - Ignition switch is in the ON position - Selector lever P position switch signal: Except P position (12 V) - Selector lever P/N position signal: Except P and N positions (0 V) • Status 2 <ul style="list-style-type: none"> - Ignition switch is in the ON position - Selector lever P position switch signal: P position (0 V) - Selector lever P/N position signal: P or N positions (12 V)
B2604: PNP/CLUTCH SW	Inhibit steering lock	500 ms after any of the following BCM recognition conditions are fulfilled <ul style="list-style-type: none"> • Status 1 <ul style="list-style-type: none"> - Ignition switch is in the ON position - Selector lever P/N position signal: P or N position (12 V) - Shift position signal (CAN): P or N position • Status 2 <ul style="list-style-type: none"> - Ignition switch is in the ON position - Selector lever P/N position signal: Except P and N positions (0 V) - Shift position signal (CAN): Except P and N position
B2605: PNP/CLUTCH SW	Inhibit steering lock	500 ms after any of the following BCM recognition conditions are fulfilled <ul style="list-style-type: none"> • Status 1 <ul style="list-style-type: none"> - Power position: IGN - Selector lever P/N position signal: Except P and N positions (0 V) - Interlock/PNP switch signal (CAN): OFF • Status 2 <ul style="list-style-type: none"> - Ignition switch is in the ON position - Selector lever P/N position signal: P or N position (12 V) - Interlock/PNP switch signal (CAN): ON
B2608: STARTER RELAY	Inhibit engine cranking	500 ms after the following signal communication status becomes consistent <ul style="list-style-type: none"> • Starter motor relay control signal • Starter relay status signal (CAN)
B2609: S/L STATUS	<ul style="list-style-type: none"> • Inhibit engine cranking • Inhibit steering lock 	When the following steering lock conditions agree <ul style="list-style-type: none"> • BCM steering lock control status • Steering lock condition No. 1 signal status • Steering lock condition No. 2 signal status
B260B: STEERING LOCK UNIT	Inhibit steering lock	Erase DTC

BCM (BODY CONTROL MODULE)

< ECU DIAGNOSIS INFORMATION >

Display contents of CONSULT	Fail-safe	Cancellation
B260D: STEERING LOCK UNIT	Inhibit steering lock	Erase DTC
B260F: ENG STATE SIG LOST	Inhibit engine cranking	When any of the following conditions are fulfilled <ul style="list-style-type: none"> Power position changes to ACC Receives engine status signal (CAN)
B2612: S/L STATUS	<ul style="list-style-type: none"> Inhibit engine cranking Inhibit steering lock 	When any of the following conditions are fulfilled <ul style="list-style-type: none"> Steering lock unit status signal (CAN) is received normally The BCM steering lock control status matches the steering lock status recognized by the steering lock unit status signal (CAN from IPDM E/R)
B2619: BCM	Inhibit engine cranking	1 second after the steering lock unit power supply output control inside BCM becomes normal
B26EF: STRG LCK RELAY OFF	Inhibit engine cranking	When the following conditions are fulfilled <ul style="list-style-type: none"> Steering lock relay signal (CAN): ON Steering lock unit status signal (CAN): ON
B26F0: STRG LCK RELAY ON	Inhibit engine cranking	When the following conditions are fulfilled <ul style="list-style-type: none"> Steering lock relay signal (CAN): OFF Steering lock unit status signal (CAN): OFF
B26F1: IGN RELAY OFF	Inhibit engine cranking	When the following conditions are fulfilled <ul style="list-style-type: none"> Ignition switch ON signal (CAN: Transmitted from BCM): ON Ignition switch ON signal (CAN: Transmitted from IPDM E/R): ON
B26F2: IGN RELAY ON	Inhibit engine cranking	When the following conditions are fulfilled <ul style="list-style-type: none"> Ignition switch ON signal (CAN: Transmitted from BCM): OFF Ignition switch ON signal (CAN: Transmitted from IPDM E/R): OFF
B26F3: START CONT RLY ON	Inhibit engine cranking	When the following conditions are fulfilled <ul style="list-style-type: none"> Starter control relay signal (CAN: Transmitted from BCM): OFF Starter control relay signal (CAN: Transmitted from IPDM E/R): OFF
B26F4: START CONT RLY OFF	Inhibit engine cranking	When the following conditions are fulfilled <ul style="list-style-type: none"> Starter control relay signal (CAN: Transmitted from BCM): ON Starter control relay signal (CAN: Transmitted from IPDM E/R): ON
B26F7: BCM	Inhibit engine cranking by Intelligent Key system	When room antenna and luggage room antenna functions normally
U0415: VEHICLE SPEED	Inhibit steering lock	When vehicle speed signal (Meter) (CAN) is received normally

HIGH FLASHER OPERATION

BCM detects the turn signal lamp circuit status by the current value.

BCM increases the turn signal lamp blinking speed if the bulb or harness open is detected with the turn signal lamp operating.

NOTE:

The blinking speed is normal while activating the hazard warning lamp.

REAR WIPER MOTOR PROTECTION

BCM detects the rear wiper stopping position according to the rear wiper stop position signal.

When the rear wiper stop position signal does not change for more than 5 seconds while driving the rear wiper, BCM stops power supply to protect the rear wiper motor.

Condition of cancellation

1. More than 1 minute is passed after the rear wiper stop.
2. Turn rear wiper switch OFF.
3. Operate the rear wiper switch or rear washer switch.

WITH INTELLIGENT KEY : DTC Inspection Priority Chart

INFOID:000000005133233

If some DTCs are displayed at the same time, perform inspections one by one based on the following priority chart.

BCM (BODY CONTROL MODULE)

< ECU DIAGNOSIS INFORMATION >

Priority	DTC
1	B2562: LOW VOLTAGE
2	<ul style="list-style-type: none"> • U1000: CAN COMM CIRCUIT • U1010: CONTROL UNIT (CAN)
3	<ul style="list-style-type: none"> • B2192: ID DISCORD BCM-ECM • B2193: CHAIN OF BCM-ECM • B2195: ANTI-SCANNING • B2196: DONGLE NG • B2198: NATS ANTENNA AMP
4	<ul style="list-style-type: none"> • B2013: ID DISCORD BCM-S/L • B2014: CHAIN OF S/L-BCM • B2553: IGNITION RELAY • B2555: STOP LAMP • B2556: PUSH-BTN IGN SW • B2557: VEHICLE SPEED • B2601: SHIFT POSITION • B2602: SHIFT POSITION • B2603: SHIFT POSI STATUS • B2604: PNP/CLUTCH SW • B2605: PNP/CLUTCH SW • B2608: STARTER RELAY • B2609: S/L STATUS • B260B: STEERING LOCK UNIT • B260C: STEERING LOCK UNIT • B260D: STEERING LOCK UNIT • B260F: ENG STATE SIG LOST • B2612: S/L STATUS • B2614: BCM • B2615: BCM • B2616: BCM • B2618: BCM • B2619: BCM • B261A: PUSH-BTN IGN SW • B26E9: LOCK MALFUNCTION • B26EF: STRG LCK RELAY OFF • B26F0: STRG LCK RELAY ON • B26F1: IGN RELAY OFF • B26F2: IGN RELAY ON • B26F3: START CONT RLY ON • B26F4: START CONT RLY OFF • B26F5: STRG LCK STS SW • B26F6: BCM • B26F7: BCM • B26F8: BCM • B26FC: KEY REGISTRATION • C1729: VHCL SPEED SIG ERR • U0415: VEHICLE SPEED

BCM (BODY CONTROL MODULE)

< ECU DIAGNOSIS INFORMATION >

Priority	DTC	
5	<ul style="list-style-type: none"> • C1704: LOW PRESSURE FL • C1705: LOW PRESSURE FR • C1706: LOW PRESSURE RR • C1707: LOW PRESSURE RL • C1708: [NO DATA] FL • C1709: [NO DATA] FR • C1710: [NO DATA] RR • C1711: [NO DATA] RL • C1712: [CHECKSUM ERR] FL • C1713: [CHECKSUM ERR] FR • C1714: [CHECKSUM ERR] RR • C1715: [CHECKSUM ERR] RL • C1716: [PRESSDATA ERR] FL • C1717: [PRESSDATA ERR] FR • C1718: [PRESSDATA ERR] RR • C1719: [PRESSDATA ERR] RL • C1720: [CODE ERR] FL • C1721: [CODE ERR] FR • C1722: [CODE ERR] RR • C1723: [CODE ERR] RL • C1724: [BATT VOLT LOW] FL • C1725: [BATT VOLT LOW] FR • C1726: [BATT VOLT LOW] RR • C1727: [BATT VOLT LOW] RL • C1734: CONTROL UNIT 	A B C D E F G
6	<ul style="list-style-type: none"> • B2621: INSIDE ANTENNA • B2622: INSIDE ANTENNA 	H
7	<ul style="list-style-type: none"> • B2626: OUTSIDE ANTENNA • B2627: OUTSIDE ANTENNA • B2628: OUTSIDE ANTENNA 	I

WITH INTELLIGENT KEY : DTC Index

INFOID:000000005133234

NOTE:

The details of time display are as follows.

- CRNT: A malfunction is detected now.
- PAST: A malfunction was detected in the past.

IGN counter is displayed on Freeze Frame Data. For details of Freeze Frame Data, refer to [BCS-18, "COMMON ITEM : CONSULT-III Function \(BCM - COMMON ITEM\)"](#).

CONSULT display	Fail-safe	Freeze Frame Data •Vehicle Speed •Odo/Trip Meter •Vehicle Condition	Intelligent Key warning lamp ON	Tire pressure monitor warning lamp ON	Reference page
No DTC is detected. further testing may be required.	—	—	—	—	—
U1000: CAN COMM	—	—	—	—	BCS-39
U1010: CONTROL UNIT (CAN)	—	—	—	—	BCS-40
U0415: VEHICLE SPEED	×	—	×	—	BCS-41
B2013: ID DISCORD BCM-S/L	×	×	×	—	SEC-45
B2014: CHAIN OF S/L-BCM	×	×	×	—	SEC-46
B2192: ID DISCORD BCM-ECM	×	—	—	—	SEC-35
B2193: CHAIN OF BCM-ECM	×	—	—	—	SEC-37
B2195: ANTI-SCANNING	×	—	—	—	SEC-38
B2196: DONGLE NG	×	—	—	—	SEC-39

BCM (BODY CONTROL MODULE)

< ECU DIAGNOSIS INFORMATION >

CONSULT display	Fail-safe	Freeze Frame Data •Vehicle Speed •Odo/Trip Meter •Vehicle Condition	Intelligent Key warning lamp ON	Tire pressure monitor warning lamp ON	Reference page
B2198: NATS ANTENNA AMP	×	—	—	—	SEC-41
B2553: IGNITION RELAY	—	×	×	—	PCS-78
B2555: STOP LAMP	—	×	×	—	SEC-49
B2556: PUSH-BTN IGN SW	—	×	×	—	SEC-51
B2557: VEHICLE SPEED	×	×	×	—	SEC-53
B2562: LOW VOLTAGE	—	×	—	—	BCS-42
B2601: SHIFT POSITION	×	×	×	—	SEC-54
B2602: SHIFT POSITION	×	×	×	—	SEC-57
B2603: SHIFT POSI STATUS	×	×	×	—	SEC-60
B2604: PNP/CLUTCH SW	×	×	×	—	SEC-65
B2605: PNP/CLUTCH SW	×	×	×	—	SEC-68
B2608: STARTER RELAY	×	×	×	—	SEC-70
B2609: S/L STATUS	×	×	×	—	SEC-72
B260B: STEERING LOCK UNIT	×	×	×	—	SEC-75
B260C: STEERING LOCK UNIT	—	×	×	—	SEC-76
B260D: STEERING LOCK UNIT	×	×	×	—	SEC-77
B260F: ENG STATE SIG LOST	×	×	×	—	SEC-78
B2612: S/L STATUS	×	×	×	—	SEC-79
B2614: BCM	—	×	×	—	PCS-80
B2615: BCM	—	×	×	—	PCS-83
B2616: BCM	—	×	×	—	PCS-86
B2618: BCM	—	×	×	—	PCS-89
B2619: BCM	×	×	×	—	SEC-82
B261A: PUSH-BTN IGN SW	—	×	×	—	PCS-90
B2621: INSIDE ANTENNA	—	×	—	—	DLK-44
B2622: INSIDE ANTENNA	—	×	—	—	DLK-46
B2626: OUTSIDE ANTENNA	—	×	—	—	DLK-48
B2627: OUTSIDE ANTENNA	—	×	—	—	DLK-50
B2628: OUTSIDE ANTENNA	—	×	—	—	DLK-52
B26E9: LOCK MALFUNCTION	—	×	× (Turn ON for 15 seconds)	—	SEC-83
B26EF: STRG LCK RELAY OFF	×	×	×	—	SEC-84
B26F0: STRG LCK RELAY ON	×	×	×	—	SEC-86
B26F1: IGN RELAY OFF	×	×	×	—	PCS-92
B26F2: IGN RELAY ON	×	×	×	—	PCS-95
B26F3: START CONT RLY ON	×	×	×	—	SEC-87
B26F4: START CONT RLY OFF	×	×	×	—	SEC-88
B26F5: STRG LCK STS SW	—	×	×	—	SEC-90
B26F6: BCM	—	×	×	—	PCS-98
B26F7: BCM	×	×	×	—	SEC-93
B26F8: BCM	—	×	×	—	SEC-94

BCM (BODY CONTROL MODULE)

< ECU DIAGNOSIS INFORMATION >

CONSULT display	Fail-safe	Freeze Frame Data •Vehicle Speed •Odo/Trip Meter •Vehicle Condition	Intelligent Key warning lamp ON	Tire pressure monitor warning lamp ON	Reference page
B26FC: KEY REGISTRATION	—	×	×	—	SEC-95
C1704: LOW PRESSURE FL	—	—	—	×	WT-16
C1705: LOW PRESSURE FR	—	—	—	×	
C1706: LOW PRESSURE RR	—	—	—	×	
C1707: LOW PRESSURE RL	—	—	—	×	
C1708: [NO DATA] FL	—	—	—	×	WT-18
C1709: [NO DATA] FR	—	—	—	×	
C1710: [NO DATA] RR	—	—	—	×	
C1711: [NO DATA] RL	—	—	—	×	
C1712: [CHECKSUM ERR] FL	—	—	—	×	WT-21
C1713: [CHECKSUM ERR] FR	—	—	—	×	
C1714: [CHECKSUM ERR] RR	—	—	—	×	
C1715: [CHECKSUM ERR] RL	—	—	—	×	
C1716: [PRESSDATA ERR] FL	—	—	—	×	WT-24
C1717: [PRESSDATA ERR] FR	—	—	—	×	
C1718: [PRESSDATA ERR] RR	—	—	—	×	
C1719: [PRESSDATA ERR] RL	—	—	—	×	
C1720: [CODE ERR] FL	—	—	—	×	WT-26
C1721: [CODE ERR] FR	—	—	—	×	
C1722: [CODE ERR] RR	—	—	—	×	
C1723: [CODE ERR] RL	—	—	—	×	
C1724: [BATT VOLT LOW] FL	—	—	—	×	WT-29
C1725: [BATT VOLT LOW] FR	—	—	—	×	
C1726: [BATT VOLT LOW] RR	—	—	—	×	
C1727: [BATT VOLT LOW] RL	—	—	—	×	
C1729: VHCL SPEED SIG ERR	—	—	—	×	WT-32
C1734: CONTROL UNIT	—	—	—	×	WT-34

WITHOUT INTELLIGENT KEY

WITHOUT INTELLIGENT KEY : Reference Value

INFOID:0000000005133235

VALUES ON THE DIAGNOSIS TOOL

Monitor Item	Condition	Value/Status
IGN ON SW	Ignition switch OFF or ACC	Off
	Ignition switch ON	On
KEY ON SW	Mechanical key is removed from key cylinder	Off
	Mechanical key is inserted to key cylinder	On
CDL LOCK SW	Door lock/unlock switch does not operate	Off
	Press door lock/unlock switch to the lock side	On
CDL UNLOCK SW	Door lock/unlock switch does not operate	Off
	Press door lock/unlock switch to the unlock side	On

BCM (BODY CONTROL MODULE)

< ECU DIAGNOSIS INFORMATION >

Monitor Item	Condition	Value/Status
DOOR SW-DR	Driver's door closed	Off
	Driver's door opened	On
DOOR SW-AS	Passenger door closed	Off
	Passenger door opened	On
DOOR SW-RR	Rear RH door closed	Off
	Rear RH door opened	On
DOOR SW-RL	Rear LH door closed	Off
	Rear LH door opened	On
BACK DOOR SW	Back door closed	Off
	Back door opened	On
LOCK STATUS	NOTE: The item is indicated, but not monitored.	Off
ACC ON SW	Ignition switch OFF	Off
	Ignition switch ACC or ON	On
KEYLESS LOCK	"LOCK" button of key fob is not pressed	Off
	"LOCK" button of key fob is pressed	On
KEYLESS UNLOCK	"UNLOCK" button of key fob is not pressed	Off
	"UNLOCK" button of key fob is pressed	On
SHOCK SENSOR	NOTE: The item is indicated, but not monitored.	NORMAL
KEY CYL LK-SW	Other than driver door key cylinder LOCK position	Off
	Driver door key cylinder LOCK position	On
KEY CYL UN-SW	Other than driver door key cylinder UNLOCK position	Off
	Driver door key cylinder UNLOCK position	On
VEHICLE SPEED	While driving	Equivalent to speedometer reading
REAR DEF SW	Rear window defogger switch OFF	Off
	Rear window defogger switch ON	On
REVERSE SW CAN	NOTE: The item is indicated, but not used.	Off
		On
TAIL LAMP SW	Lighting switch OFF	Off
	Lighting switch 1ST	On
FR FOG SW	Front fog lamp switch OFF	Off
	Front fog lamp switch ON	On
BUCKLE SW	The seat belt (driver side) is fastened. [Seat belt switch (driver side) OFF]	Off
	The seat belt (driver side) is unfastened. [Seat belt switch (driver side) ON]	On
TRNK/HAT MNTR	NOTE: The item is indicated, but not monitored.	Off
ACC SW	Ignition switch OFF	Off
	Ignition switch ACC or ON	On
KYLS TRNK/HAT	NOTE: The item is indicated, but not monitored.	Off
KEYLESS PANIC	PANIC button of key fob is not pressed	Off
	PANIC button of key fob is pressed	On
HI BEAM SW	Lighting switch OFF	Off
	Lighting switch HI	On

BCM (BODY CONTROL MODULE)

< ECU DIAGNOSIS INFORMATION >

Monitor Item	Condition	Value/Status	
HEAD LAMP SW 1	Lighting switch OFF	Off	A
	Lighting switch 2ND	On	
HEAD LAMP SW 2	Lighting switch OFF	Off	B
	Lighting switch 2ND	On	
AUTO LIGHT SW	Lighting switch OFF	Off	C
	Lighting switch AUTO	On	
PASSING SW	Other than lighting switch PASS	Off	D
	Lighting switch PASS	On	
RR FOG SW	NOTE: The item is indicated, but not monitored.	Off	
TURN SIGNAL R	Turn signal switch OFF	Off	E
	Turn signal switch RH	On	
TURN SIGNAL L	Turn signal switch OFF	Off	F
	Turn signal switch LH	On	
PKB SW	Parking brake switch is OFF	Off	G
	Parking brake switch is ON	On	
ENGINE RUN	Engine stopped	Off	H
	Engine running	On	
OPTI SEN (DTCT)	Bright outside of the vehicle	Close to 5 V	I
	Dark outside of the vehicle	Close to 0 V	
OPTI SEN (FILT)	Bright outside of the vehicle (Lighting switch AUTO)	Close to 5 V	J
	Dark outside of the vehicle (Lighting switch AUTO)	Close to 1.50 V	
LIG SEN COND	NOTE: The item is indicated, but not monitored.	OFF	K
IGN SW CAN	Ignition switch OFF or ACC	Off	
	Ignition switch ON	On	
FR WIPER HI	Front wiper switch OFF	Off	
	Front wiper switch HI	On	
FR WIPER LOW	Front wiper switch OFF	Off	DEF
	Front wiper switch LO	On	
FR WIPER INT	Front wiper switch OFF	Off	
	Front wiper switch INT	On	M
FR WASHER SW	Front washer switch OFF	Off	
	Front washer switch ON	On	
INT VOLUME	Wiper intermittent dial is in a dial position 1 - 7	1 - 7	N
FR WIPER STOP	Any position other than front wiper stop position	Off	
	Front wiper stop position	On	O
RR WIPER ON	Rear wiper switch OFF	Off	
	Rear wiper switch ON	On	
RR WIPER INT	Rear wiper switch OFF	Off	P
	Rear wiper switch INT	On	
RR WASHER SW	Rear washer switch OFF	Off	
	Rear washer switch ON	On	
RR WIPER STOP	Rear wiper stop position	Off	
	Other than rear wiper stop position	On	

BCM (BODY CONTROL MODULE)

< ECU DIAGNOSIS INFORMATION >

Monitor Item	Condition	Value/Status
RAIN SENSOR	NOTE: The item is indicated, but not monitored.	Off
HAZARD SW	Hazard switch OFF	Off
	Hazard switch ON	On
FAN ON SIG	Blower control dial OFF	Off
	Other than blower control dial OFF	On
AIR COND SW	<ul style="list-style-type: none"> • Air conditioner OFF (A/C switch indicator OFF) (Automatic air conditioner) • A/C switch OFF (Manual air conditioner) 	Off
	<ul style="list-style-type: none"> • Air conditioner ON (A/C switch indicator ON) (Automatic air conditioner) • A/C switch ON (Manual air conditioner) 	On
THERMO AMP NOTE: At models with automatic air conditioner this item is not monitored.	Ignition switch ON	Off
	Evaporator is extremely low temperature	On
FR DEF SW	Other than A/C mode defroster ON position	Off
	A/C mode defroster ON position	On
KEYLESS TRUNK	NOTE: The item is indicated, but not monitored.	Off
TRNK OPNR SW	NOTE: The item is indicated, but not monitored.	Off
TRNK OPN MNTR	NOTE: The item is indicated, but not monitored.	Off
HOOD SW	Close the hood	Off
	Open the hood	On
TRANSPONDER	Other than the ignition switch is ON by key registered to BCM.	Off
	The ignition switch is ON by key registered to BCM.	On
INTELLI KEY	NOTE: The item is indicated, but not used.	Off
AUTO RELOCK	NOTE: The item is indicated, but not monitored.	Off
OIL PRESS SW	<ul style="list-style-type: none"> • Ignition switch OFF or ACC • Engine running 	Off
	Ignition switch ON	On
BRAKE SW	Brake pedal is not depressed	Off
	Brake pedal is depressed	On

BCM (BODY CONTROL MODULE)

< ECU DIAGNOSIS INFORMATION >

TERMINAL LAYOUT

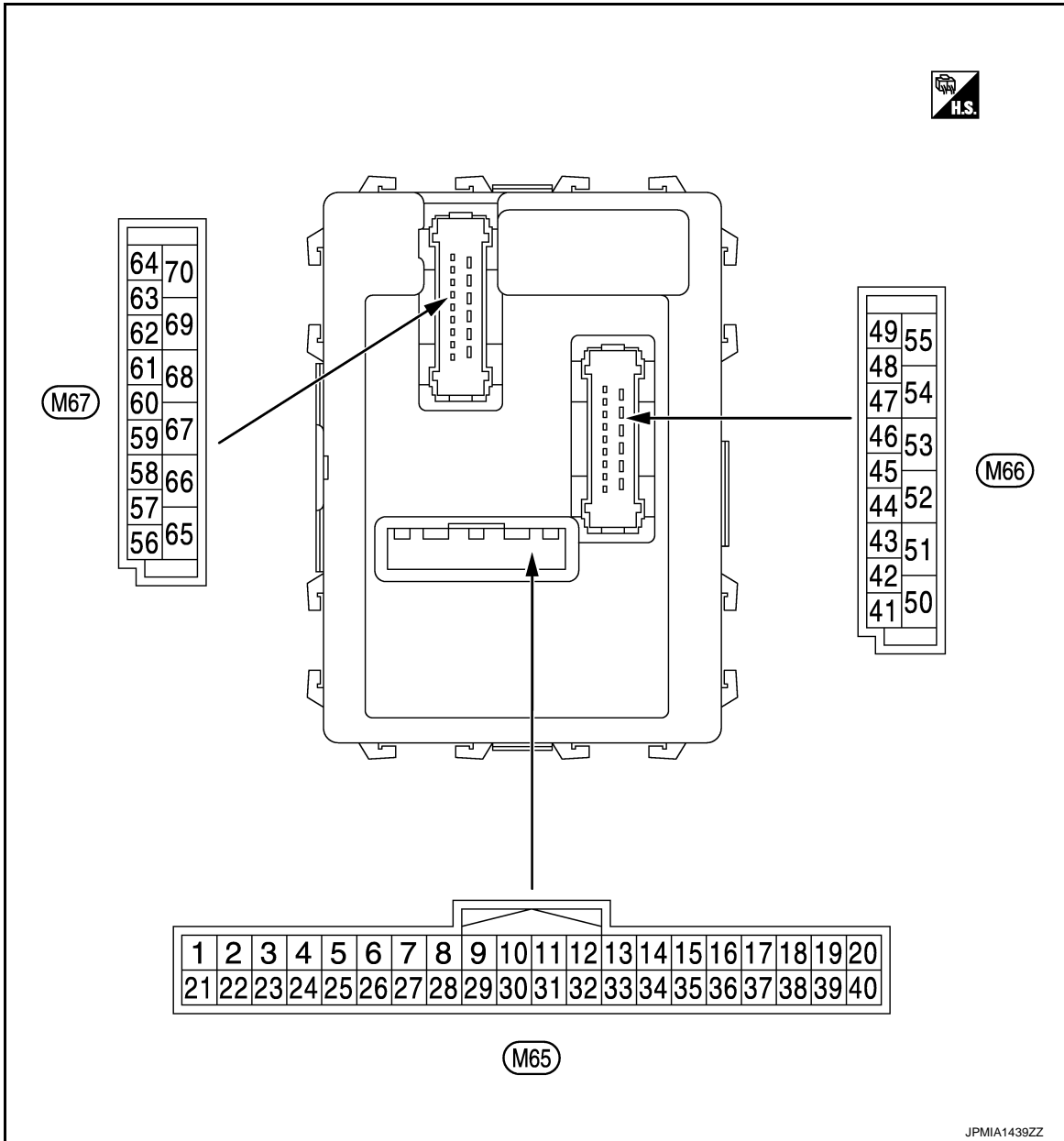

NOTE:

- M65, M66: White
- M67: Black

PHYSICAL VALUES

A
B
C
D
E
F
G
H
I
J
K
DEF
M
N
O
P

BCM (BODY CONTROL MODULE)

< ECU DIAGNOSIS INFORMATION >

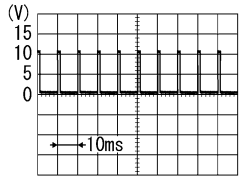
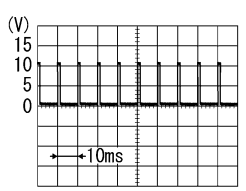
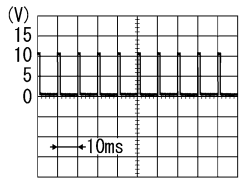
Terminal No. (Wire color)		Description		Condition	Value (Approx.)	
+	-	Signal name	Input/ Output			
2 (BR/W)	Ground	Combination switch INPUT 5	Input	Combination switch (Wiper intermit- tent dial 4)	All switch OFF	0 V
					Turn signal switch RH	
					Lighting switch HI	
					Lighting switch 1ST	
					Lighting switch 2ND	
3 (GR)	Ground	Combination switch INPUT 4	Input	Combination switch (Wiper intermit- tent dial 4)	All switch OFF	0 V
					Turn signal switch LH	
					Lighting switch PASS	
					Lighting switch 2ND	
					Front fog lamp switch ON	
4 (L/Y)	Ground	Combination switch INPUT 3	Input	Combination switch (Wiper intermit- tent dial 4)	All switch OFF	0 V
					Front wiper switch LO	
					Front wiper switch MIST	
					Front wiper switch INT	
					Lighting switch AUTO	

BCM (BODY CONTROL MODULE)

< ECU DIAGNOSIS INFORMATION >

Terminal No. (Wire color)		Description		Condition	Value (Approx.)	
+	-	Signal name	Input/ Output			
5 (G)	Ground	Combination switch INPUT 2	Input	Combination switch	All switch OFF (Wiper intermittent dial 4)	0 V
					Front washer switch (Wiper intermittent dial 4)	
					Rear washer switch ON (Wiper intermittent dial 4)	
					Any of the condition below with all switch OFF <ul style="list-style-type: none"> • Wiper intermittent dial 1 • Wiper intermittent dial 5 • Wiper intermittent dial 6 	
Rear wiper switch ON (Wiper intermittent dial 4)		0.8 V				
6 (L/R)	Ground	Combination switch INPUT 1	Input	Combination switch	All switch OFF (Wiper intermittent dial 4)	0 V
					Front wiper switch HI (Wiper intermittent dial 4)	
					Rear wiper switch INT (Wiper intermittent dial 4)	
					Wiper intermittent dial 3 (All switch OFF)	
					Any of the condition below with all switch OFF <ul style="list-style-type: none"> • Wiper intermittent dial 1 • Wiper intermittent dial 2 	
Any of the condition below with all switch OFF <ul style="list-style-type: none"> • Wiper intermittent dial 6 • Wiper intermittent dial 7 		0.8 V				

A
B
C
D
E
F
G
H
I
J
K
DEF
M
N
O
P

BCM (BODY CONTROL MODULE)

< ECU DIAGNOSIS INFORMATION >

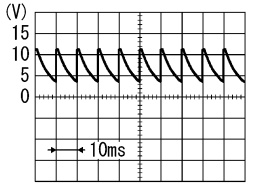
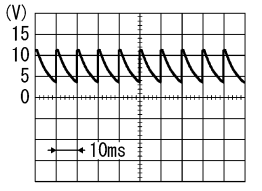
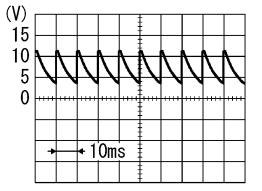
Terminal No. (Wire color)		Description		Condition		Value (Approx.)
+	-	Signal name	Input/ Output			
7 (W/R)	Ground	Door key cylinder switch UNLOCK	Input	Door key cylin- der switch	NEUTRAL position	 7.0 - 8.0 V
					UNLOCK position	0 V
8 (W/B)	Ground	Door key cylinder switch LOCK	Input	Door key cylin- der switch	NEUTRAL position	12 V
					LOCK position	0 V
9 (R)	Ground	Stop lamp switch	Input	Stop lamp switch	OFF (Brake pedal is not depressed)	0 V
					ON (Brake pedal is de- pressed)	Battery voltage
10 (W/L)	Ground	Rear window defog- ger switch	Input	Rear window defogger switch	OFF (Not pressed)	12 V
					ON (Pressed)	0 V
11 (L/Y)	Ground	Ignition switch ACC	Input	Ignition switch OFF	0 V	
				Ignition switch ACC or ON	Battery voltage	
12 (SB)	Ground	Passenger door switch	Input	Passenger door switch	OFF (When passenger door closed)	 7.0 - 8.0 V
					ON (When passenger door opened)	0 V
13 (GR/L)	Ground	Rear RH door switch	Input	Rear RH door switch	OFF (When rear RH door closed)	 7.0 - 8.0 V
					ON (When rear RH door opened)	0 V
14 (L/B)	Ground	Optical sensor	Input	Ignition switch ON	When bright outside of the vehicle	Close to 5 V
				When dark outside of the vehicle	Close to 0 V	

BCM (BODY CONTROL MODULE)

< ECU DIAGNOSIS INFORMATION >

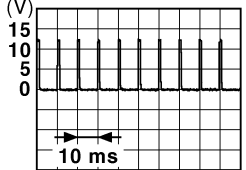
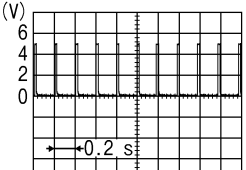
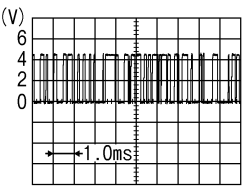
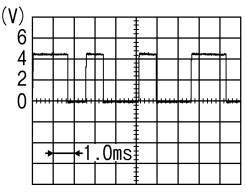
Terminal No. (Wire color)		Description		Condition		Value (Approx.)
+	-	Signal name	Input/ Output			
15 (V/W)	Ground	Tire pressure warning check switch	Input	Ignition switch OFF		 <small>JPMIA0012GB</small> 1.0 - 1.5 V
17 (R/G)	Ground	Optical sensor power supply	Output	Ignition switch	OFF, ACC	0 V
					ON	5 V
18 (V)	Ground	Receiver and sensor ground	Input	Ignition switch ON		0 V
19 (BR)	Ground	Remote keyless entry receiver power supply	Input	Ignition switch OFF	Insert mechanical key into ignition key cylinder	0 V
					Remove mechanical key from ignition key cylinder (Any door opened)	5 V
					Remove mechanical key from ignition key cylinder (Any door closed)	 <small>JPMIA0338JP</small>
20 (G/Y)	Ground	Remote keyless entry receiver communication	Input	Ignition switch OFF	Insert mechanical key into ignition key cylinder	0 V
					Waiting	 <small>PIIB7728J</small>
					Signal receiving	 <small>PIIB7729J</small>
21 (P/L)	Ground	Immobilizer antenna (Clock)	Input/ Output	During waiting	Ignition switch is pressed while inserting the key into the key slot.	Just after pressing ignition switch. Pointer of tester should move.

A
B
C
D
E
F
G
H
I
J
K
DEF
M
N
O
P

BCM (BODY CONTROL MODULE)

< ECU DIAGNOSIS INFORMATION >

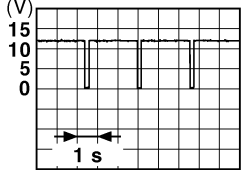
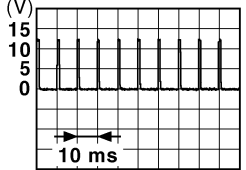
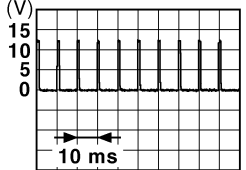
Terminal No. (Wire color)		Description		Condition		Value (Approx.)
+	-	Signal name	Input/ Output			
23 (R/Y)	Ground	Security indicator	Input	Security indicator	ON	0 V
					Blinking (Ignition switch OFF)	 <p style="text-align: right; font-size: small;">JPMIA0014GB</p>
					OFF	12 V
24 (GR/R)	Ground	Dongle link	Input/ Output	Ignition switch OFF		5 V
25 (LG)	Ground	Immobilizer antenna (Rx, Tx)	Input/ Output	During waiting	Ignition switch is pressed while inserting the key into the key slot.	Just after pressing ignition switch. Pointer of tester should move.
26*1 (GR)	Ground	Thermo control amp.	Input	Ignition switch ON		0 V
				Evaporator is extremely low temperature		12 V
27 (Y/G)*2 (Y/R)*3	Ground	A/C switch (Automatic air conditioner)	Input	A/C	OFF (A/C switch indicator: OFF)	 <p style="text-align: right; font-size: small;">JPMIA0012GB</p>
				ON (A/C switch indicator: ON)	0 V	
		A/C switch (Manual air conditioner)	A/C switch	OFF	 <p style="text-align: right; font-size: small;">JPMIA0012GB</p>	
					ON	0 V

BCM (BODY CONTROL MODULE)

< ECU DIAGNOSIS INFORMATION >

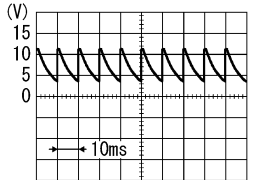
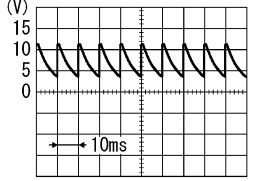
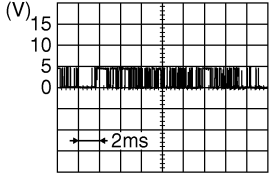
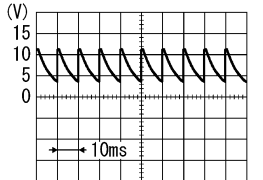
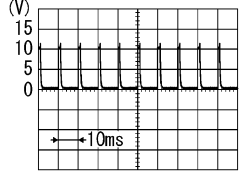
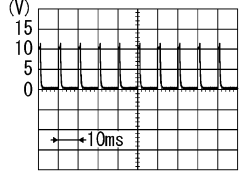
Terminal No. (Wire color)		Description		Condition	Value (Approx.)
		Signal name	Input/ Output		
+	-				
28 (G/W)	Ground	Blower fan switch (Automatic air conditioner)	Input	Blower fan switch OFF	0 V
				Blower fan switch ON	 <small>PKIB4960J</small> 7.0 - 8.0 V
		Blower fan switch (Manual air conditioner)	Fan switch	Blower fan switch OFF	 <small>PKIB4960J</small> 7.0 - 8.0 V
		Blower fan switch ON	Fan switch	0 V	
29 (L/W)	Ground	Hazard switch	Input	Hazard switch OFF	Battery voltage
				Hazard switch ON	0 V
31 (G/Y)	Ground	Front defroster switch	Input	Ignition switch ON	0 V
				Other than A/C mode defroster ON position	 <small>JPMIA0589GB</small> 8.0 - 9.0 V
32 (LG)	Ground	Combination switch OUTPUT 5	Output	Combination switch	 <small>PKIB4960J</small> 7.0 - 8.0 V
				All switch OFF (Wiper intermittent dial 4)	 <small>PKIB4956J</small> 1.0 V
				Rear wiper switch ON (Wiper intermittent dial 4)	 <small>PKIB4956J</small> 1.0 V
				Any of the condition below with all switch OFF	<ul style="list-style-type: none"> • Wiper intermittent dial 1 • Wiper intermittent dial 2 • Wiper intermittent dial 6 • Wiper intermittent dial 7

A
B
C
D
E
F
G
H
I
J
K
DEF
M
N
O
P

BCM (BODY CONTROL MODULE)

< ECU DIAGNOSIS INFORMATION >

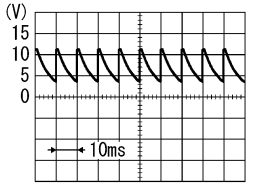
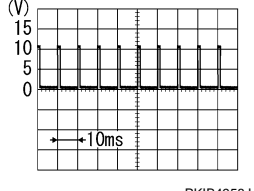
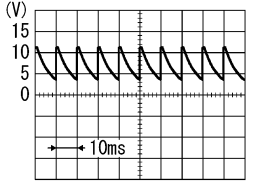
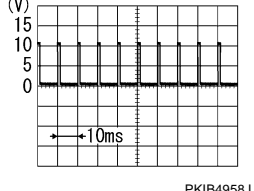
Terminal No. (Wire color)		Description		Condition	Value (Approx.)	
+	-	Signal name	Input/ Output			
33 (Y/L)	Ground	Combination switch OUTPUT 4	Output	Combination switch	All switch OFF (Wiper intermittent dial 4)	 7.0 - 8.0 V
					Lighting switch 1ST (Wiper intermittent dial 4)	 1.2 V
					Lighting switch AUTO (Wiper intermittent dial 4)	
					Rear wiper switch INT (Wiper intermittent dial 4)	
Any of the condition below with all switch OFF						
<ul style="list-style-type: none"> • Wiper intermittent dial 1 • Wiper intermittent dial 5 • Wiper intermittent dial 6 						
34 (W)	Ground	Combination switch OUTPUT 3	Output	Combination switch	All switch OFF (Wiper intermittent dial 4)	 7.0 - 8.0 V
					Lighting switch 2ND (Wiper intermittent dial 4)	 1.2 V
					Lighting switch HI (Wiper intermittent dial 4)	
					Rear washer switch ON (Wiper intermittent dial 4)	
Any of the condition below with all switch OFF						
<ul style="list-style-type: none"> • Wiper intermittent dial 1 • Wiper intermittent dial 2 • Wiper intermittent dial 3 						

BCM (BODY CONTROL MODULE)

< ECU DIAGNOSIS INFORMATION >

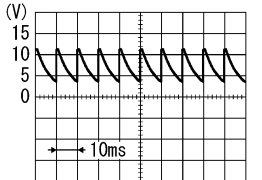
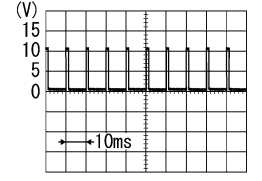
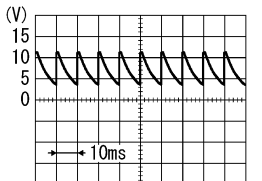
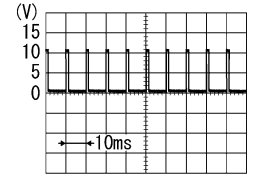
Terminal No. (Wire color)		Description		Condition	Value (Approx.)	
+	-	Signal name	Input/ Output			
35 (R/L)	Ground	Combination switch OUTPUT 2	Output	Combination switch (Wiper intermit- tent dial 4)	All switch OFF	 <p style="text-align: center;">7.0 - 8.0 V</p>
					Lighting switch 2ND	 <p style="text-align: center;">1.2 V</p>
					Lighting switch PASS	
					Front wiper switch INT	
Front wiper switch HI						
36 (L/O)	Ground	Combination switch OUTPUT 1	Output	Combination switch (Wiper intermit- tent dial 4)	All switch OFF	 <p style="text-align: center;">7.0 - 8.0 V</p>
					Turn signal switch RH	 <p style="text-align: center;">1.2 V</p>
					Turn signal switch LH	
					Front wiper switch LO (Front wiper switch MIST)	
Front washer switch ON						
37 (R/W)	Ground	Key switch	Input	Insert mechanical key into ignition key cylinder	Battery voltage	
				Remove mechanical key from ignition key cylinder	0 V	
38 (O)	Ground	Ignition switch ON	Input	Ignition switch OFF or ACC	0 V	
				Ignition switch ON	Battery voltage	
39 (L)	Ground	CAN-H	Input/ Output	—	—	
40 (P)	Ground	CAN-L	Input/ Output	—	—	

A
B
C
D
E
F
G
H
I
J
K
DEF
M
N
O
P

DEF

BCM (BODY CONTROL MODULE)

< ECU DIAGNOSIS INFORMATION >

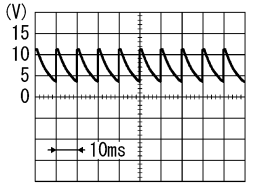
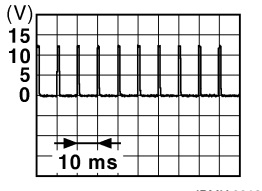
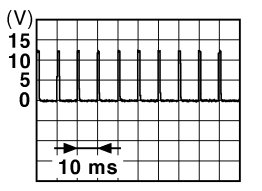
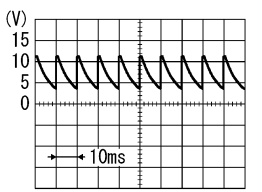
Terminal No. (Wire color)		Description		Condition	Value (Approx.)
+	-	Signal name	Input/ Output		
43 (W)	Ground	Back door switch	Input	Back door switch	 <p style="text-align: center;">7.0 - 8.0 V</p>
				OFF (When back door closed)	0 V
44 (LG)	Ground	Rear wiper stop position	Input	Ignition switch ON	12 V
				Rear wiper stop position	0 V
45 (GR)	Ground	Door lock and unlock switch LOCK	Input	Door lock and unlock switch	 <p style="text-align: center;">1.0 - 1.5 V</p>
				NEUTRAL position	0 V
46 (BR)	Ground	Door lock and unlock switch UNLOCK	Input	Door lock and unlock switch	 <p style="text-align: center;">1.0 - 1.5 V</p>
				NEUTRAL position	0 V
47 (BR/Y)	Ground	Driver door switch	Input	Driver door switch	 <p style="text-align: center;">7.0 - 8.0 V</p>
				OFF (When driver door closed)	0 V
				ON (When driver door opened)	0 V

BCM (BODY CONTROL MODULE)

< ECU DIAGNOSIS INFORMATION >

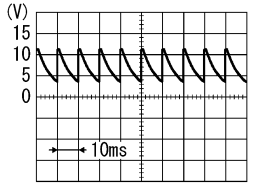
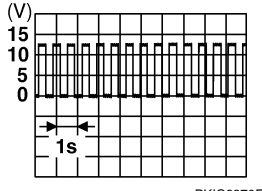
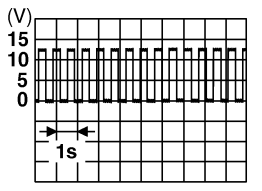
Terminal No. (Wire color)		Description		Condition	Value (Approx.)	
+	-	Signal name	Input/ Output			
48 (W/G)	Ground	Rear LH door switch	Input	Rear LH door switch	OFF (When rear LH door closed)	 7.0 - 8.0 V
				Rear LH door switch	ON (When rear LH door opened)	0 V
49 (Y)	Ground	Luggage room lamp	Output	Luggage room lamp switch	Back door is closed (Back door lamp turns OFF)	12 V
				DOOR position	Back door is opened (Back door lamp turns ON)	0 V
50*1 (SB)	Ground	A/C indicator	Output	A/C indicator	OFF	12 V
				A/C indicator	ON	0 V
54 (L/W)	Ground	Rear wiper	Output	Ignition switch	Rear wiper switch OFF	0 V
				ON	Rear wiper switch ON	12 V
56 (L)	Ground	Interior room lamp power supply	Output	Interior room lamp battery saver is activated. (Cuts the interior room lamp power supply)	Interior room lamp battery saver is activated. (Cuts the interior room lamp power supply)	0 V
				Interior room lamp battery saver is not activated. (Outputs the interior room lamp power supply)	Interior room lamp battery saver is not activated. (Outputs the interior room lamp power supply)	12 V
57 (Y)	Ground	Battery power supply	Input	Ignition switch OFF	Battery voltage	
59 (L/B)	Ground	Driver door UNLOCK	Output	Driver door	UNLOCK (Actuator is activated)	12 V
				Driver door	Other than UNLOCK (Actuator is not activated)	0 V
60 (W/B)	Ground	Turn signal LH	Output	Ignition switch ON	Turn signal switch OFF	0 V
				Ignition switch ON	Turn signal switch LH	 6.0 V
61 (W/L)	Ground	Turn signal RH	Output	Ignition switch ON	Turn signal switch OFF	0 V
				Ignition switch ON	Turn signal switch RH	 6.0 V

A
B
C
D
E
F
G
H
I
J
K
DEF
M
N
O
P

BCM (BODY CONTROL MODULE)

< ECU DIAGNOSIS INFORMATION >

Terminal No. (Wire color)		Description		Condition		Value (Approx.)
		Signal name	Input/ Output			
+	-					
63 (BR)	Ground	Interior room lamp timer control	Output	Interior room lamp	OFF	12 V
					ON	0 V
65 (V)	Ground	All doors LOCK	Output	All doors	LOCK (Actuator is activated)	12 V
					Other then LOCK (Actuator is not activated)	0 V
66 (G)	Ground	Passenger door and rear door UNLOCK	Output	Passenger door and rear door	UNLOCK (Actuator is activated)	12 V
					Other then UNLOCK (Actuator is not activated)	0 V
67 (B)	Ground	Ground	Output	Ignition switch ON		0 V
68 (L)	Ground	P/W power supply (IGN)	Output	Ignition switch ON		12 V
69 (L/W)	Ground	P/W power supply (BAT)	Output	Ignition switch OFF		12 V
70 (Y)	Ground	Battery power supply	Input	Ignition switch OFF		Battery voltage

- *1: Only manual air conditioner
- *2: Automatic air conditioner
- *3: Manual air conditioner

BCM (BODY CONTROL MODULE)

< ECU DIAGNOSIS INFORMATION >

WITHOUT INTELLIGENT KEY : Wiring Diagram - BCM -

INFOID:000000005133236

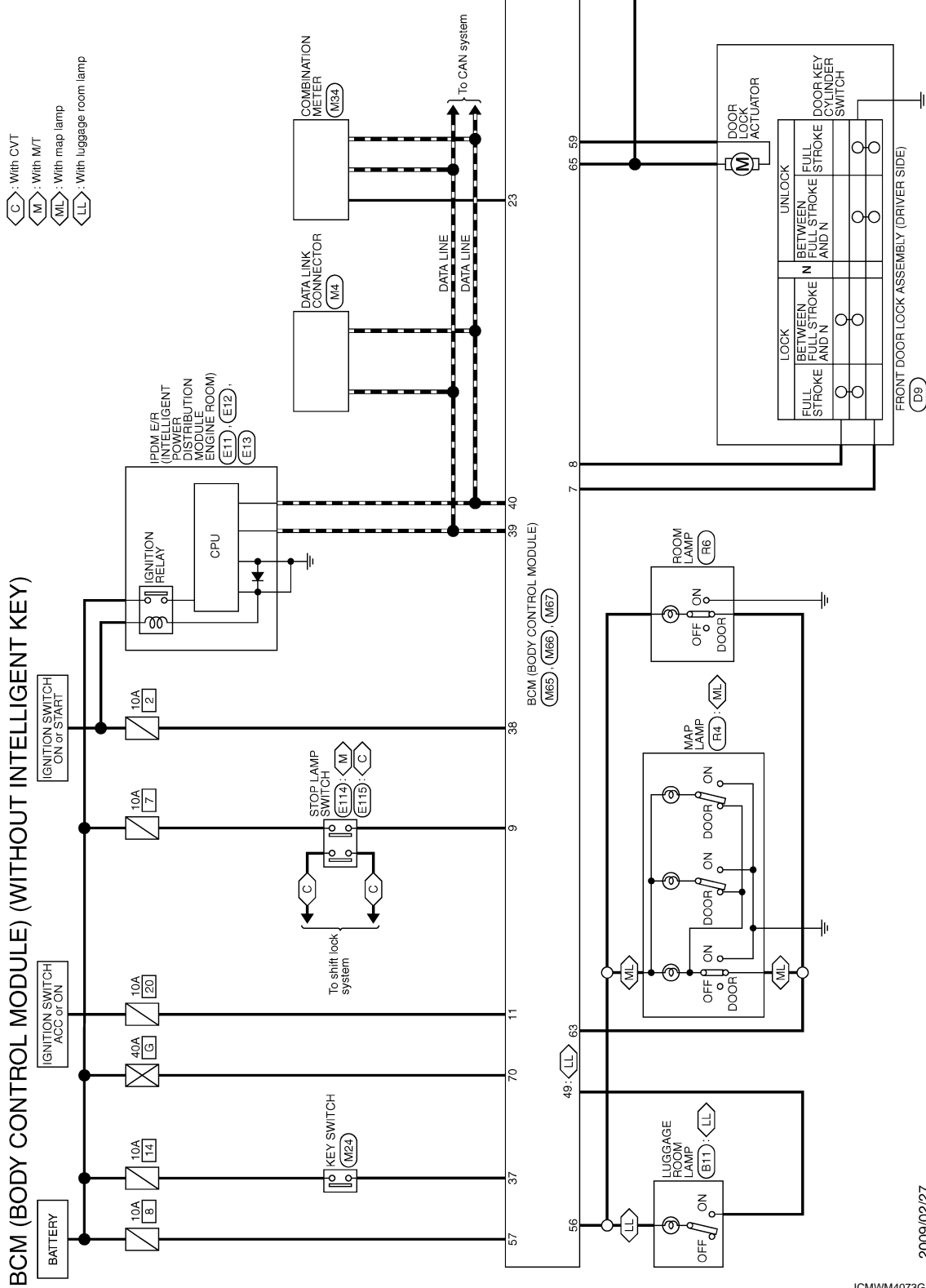

2009/02/27

JCMWM4073GB

A
B
C
D
E
F
G
H
I
J
K
DEF
M
N
O
P

BCM (BODY CONTROL MODULE)

< ECU DIAGNOSIS INFORMATION >

- AA: With auto A/C
- MA: With manual A/C
- OA: Without A/C
- XA: Except with auto A/C
- AL: With auto light system

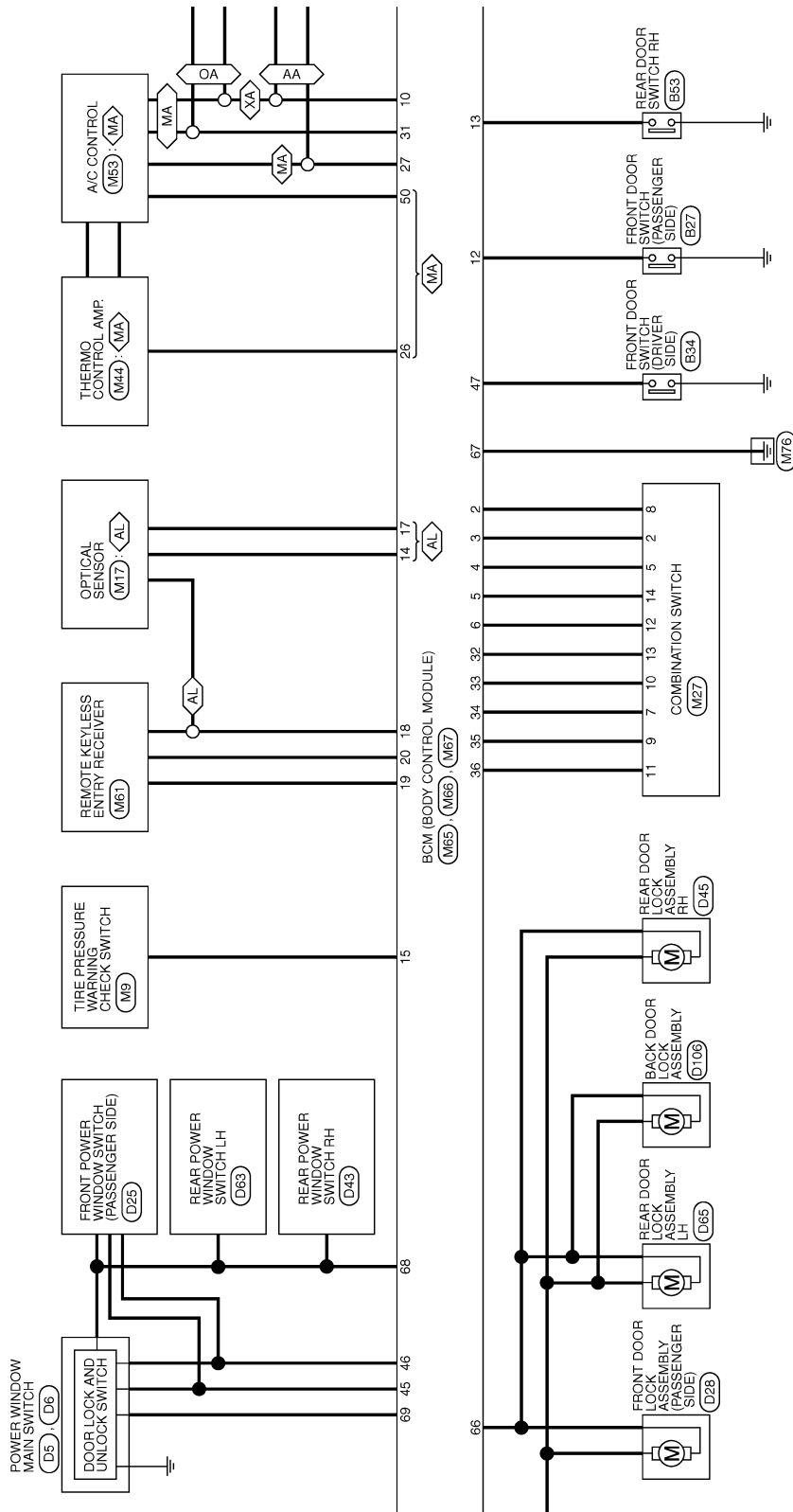

JCMWM4074GB

BCM (BODY CONTROL MODULE)

< ECU DIAGNOSIS INFORMATION >

- : For Canada
- : With auto A/C
- : Without A/C
- : Except with auto A/C

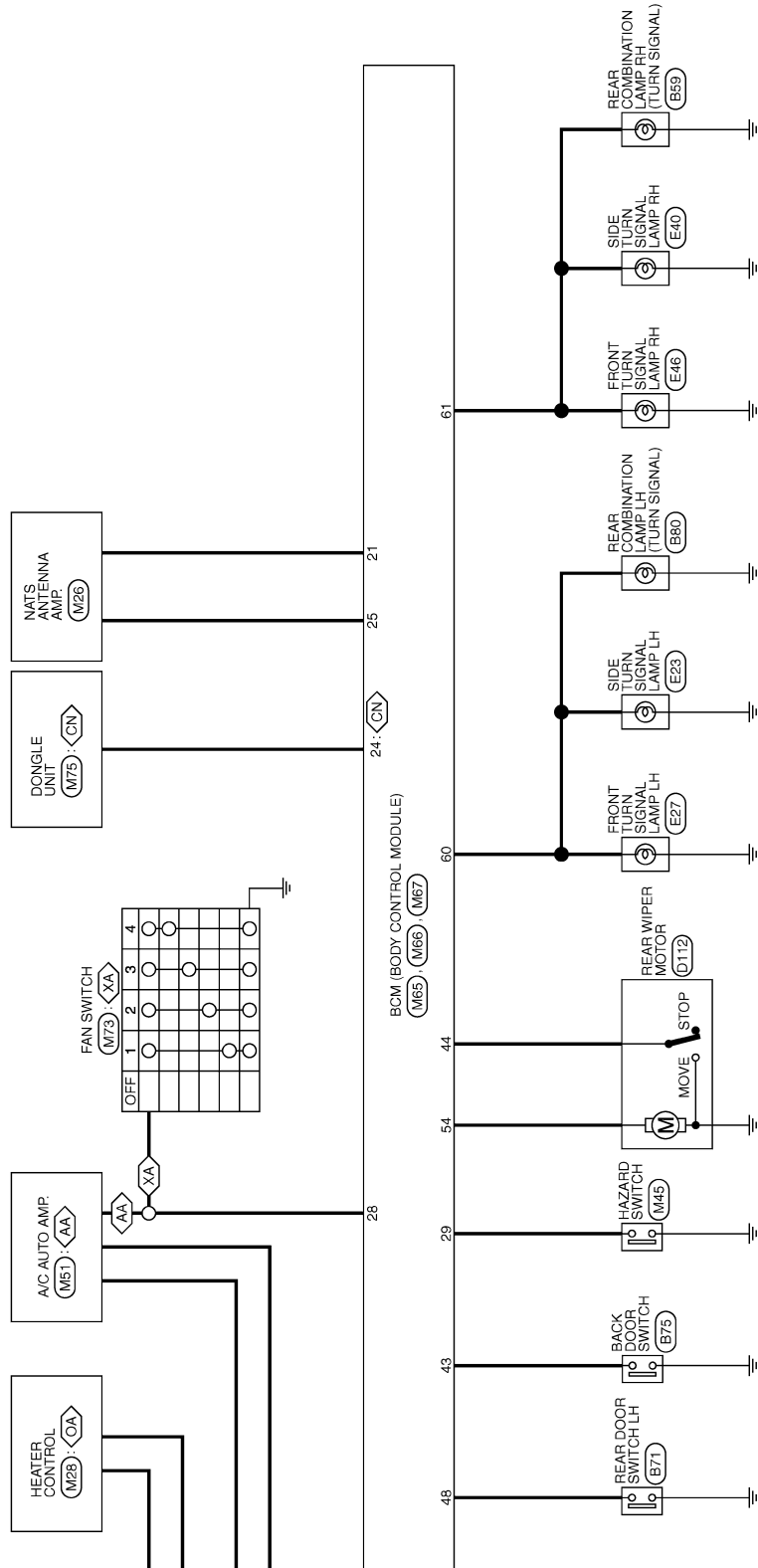

JCMWM4075GB

A
B
C
D
E
F
G
H
I
J
K
DEF
M
N
O
P

BCM (BODY CONTROL MODULE)

< ECU DIAGNOSIS INFORMATION >

40	P	CAN-L
----	---	-------

13	GR/L	REAR RH DOOR SW
14	L/B	OPTICAL SENSOR
15	V/W	TIRE PRESS WARNING CHECK SW
17	R/G	OPTICAL SENSOR POWER SUPPLY
18	V	RECEIVER SENSOR GND
19	BR	KEYLESS ENTRY RECEIVER POWER SUPPLY
20	G/Y	KEYLESS ENTRY RECEIVER COMM
21	P/L	NATS ANTENNA AMP
23	R/Y	SECURITY INDICATOR LAMP
24	GR/R	DOUBLE LINK
25	LG	NATS ANTENNA AMP
26	GR	THERMO CONTROL AMP
27	Y/G	A/C SW(With auto A/C)
28	Y/R	A/C SW(With manual A/C)
29	G/W	BLOWER FAN SW
31	L/W	HAZARD SW
32	G/Y	FR DEFROSTER SW
32	LG	COMBI SW OUTPUT 5
33	Y/L	COMBI SW OUTPUT 4
34	W	COMBI SW OUTPUT 3
35	R/L	COMBI SW OUTPUT 2
36	L/O	COMBI SW OUTPUT 1
37	R/W	KEY SWITCH
38	O	IGN
39	L	CAN-H

70	Y	BAT (F/L)
----	---	-----------

BCM (BODY CONTROL MODULE) (WITHOUT INTELLIGENT KEY)

Connector No.	M65
Connector Name	BCM (BODY CONTROL MODULE) (WITHOUT INTELLIGENT KEY)
Connector Type	TH46FW-NH



1	2	3	4	5	6	7	8	9	10	11	12	13	14	15	16	17	18	19	20	21	22	23	24	25	26	27	28	29	30	31	32	33	34	35	36	37	38	39	40
---	---	---	---	---	---	---	---	---	----	----	----	----	----	----	----	----	----	----	----	----	----	----	----	----	----	----	----	----	----	----	----	----	----	----	----	----	----	----	----

Terminal No.	Color of Wire	Signal Name [Specification]
2	BR/W	COMBI SW INPUT 5
3	GR	COMBI SW INPUT 4
4	L/Y	COMBI SW INPUT 3
5	G	COMBI SW INPUT 2
6	L/R	COMBI SW INPUT 1
7	W/R	KEY CYL UNLOCK SW
8	W/B	KEY CYL LOCK SW
9	R	STOP LAMP SW
10	W/L	REAR WINDOW DEFROGGER SW
11	L/Y	ACC
12	SB	PASSENGER DOOR SW

Connector No.	M67
Connector Name	BCM (BODY CONTROL MODULE) (WITHOUT INTELLIGENT KEY)
Connector Type	FEA09FB-FHA6-SA



56	57	58	59	60	61	62	63	64	65	66	67	68	69	70
----	----	----	----	----	----	----	----	----	----	----	----	----	----	----

Terminal No.	Color of Wire	Signal Name [Specification]
56	L	INTERIOR ROOM LAMP POWER SUPPLY
57	Y	BAT FUSE
59	L/B	DRIVER DOOR UNLOCK OUTPUT
60	W/B	TURN SIGNAL LH OUTPUT
61	W/L	TURN SIGNAL RH OUTPUT
63	BR	ROOM LAMP TIMER CONTROL
65	V	ALL DOOR LOCK OUTPUT
66	G	PASSENGER DOOR REAR DOOR UNLOCK OUTPUT
67	B	GND
68	L	POWER WINDOW POWER SUPPLY (IGN)
69	L/W	POWER WINDOW POWER SUPPLY (BAT)

Connector No.	M27
Connector Name	COMBINATION SWITCH
Connector Type	TH16FW-NH



1	2	3	4	5	6	7	8	9	10	11	12	13	14
---	---	---	---	---	---	---	---	---	----	----	----	----	----

Terminal No.	Color of Wire	Signal Name [Specification]
2	GR	INPUT 4
5	L/Y	INPUT 3
7	W	OUTPUT 3
8	BR/W	INPUT 5
9	R/L	OUTPUT 2
10	Y/L	OUTPUT 4
11	L/O	OUTPUT 1
12	L/R	INPUT 1
13	LG	OUTPUT 5
14	G	INPUT 2

Connector No.	M66
Connector Name	BCM (BODY CONTROL MODULE) (WITHOUT INTELLIGENT KEY)
Connector Type	FEA09FW-FHA6-SA



43	44	45	46	47	48	49	50	51	52	53	54
----	----	----	----	----	----	----	----	----	----	----	----

Terminal No.	Color of Wire	Signal Name [Specification]
43	W	BACK DOOR SW
44	LG	REAR WIPER STOP POSITION
45	GR	CENTRAL DOOR LOCK SW
46	BR	CENTRAL DOOR UNLOCK SW
47	BR/Y	DRIVER DOOR SW
48	W/G	REAR LH DOOR SW
49	Y	LUGGAGE ROOM LAMP
50	SB	A/C INDICATOR OUTPUT
54	L/W	REAR WIPER OUTPUT

JCMWM4076GB

INFOID:000000005133237

WITHOUT INTELLIGENT KEY : Fail-safe

FAIL-SAFE CONTROL BY DTC

BCM performs fail-safe control when any DTC are detected.

BCM (BODY CONTROL MODULE)

< ECU DIAGNOSIS INFORMATION >

Display contents of CONSULT	Fail-safe	Cancellation
B2190: NATS ANTENNA AMP	Inhibit engine cranking	Erase DTC
B2191: DIFFERENCE OF KEY	Inhibit engine cranking	Erase DTC
B2192: ID DISCORD BCM-ECM	Inhibit engine cranking	Erase DTC
B2193: CHAIN OF BCM-ECM	Inhibit engine cranking	Erase DTC
B2195: ANTI SCANNING	Inhibit engine cranking	Ignition switch ON → OFF
B2196: DONGLE NG	Inhibit engine cranking	Erase DTC

REAR WIPER MOTOR PROTECTION

BCM detects the rear wiper stopping position according to the rear wiper auto stop signal.

When the rear wiper auto stop signal does not change more than 5 seconds while driving the rear wiper, BCM stops power supply to protect the rear wiper motor.

Condition of cancellation

1. Pass more than 1 minute after the rear wiper stop.
2. Turn rear wiper switch OFF.
3. Operate the rear wiper switch or rear washer switch.

HIGH FLASHER OPERATION

BCM detects the turn signal lamp circuit status by the current value.

BCM increases the turn signal lamp blinking speed if the bulb or harness open is detected with the turn signal lamp operating.

NOTE:

The blinking speed is normal while activating the hazard warning lamp.

WITHOUT INTELLIGENT KEY : DTC Index

INFOID:000000005133238

NOTE:

Details of time display

- CRNT: Displays when there is a malfunction now or after returning to the normal condition until turning ignition switch OFF → ON again.
- 1 - 39: Displayed if any previous malfunction is present when current condition is normal. It increases like 1 → 2 → 3...38 → 39 after returning to the normal condition whenever ignition switch OFF → ON. The counter remains at 39 even if the number of cycles exceeds it. It is counted from 1 again when turning ignition switch OFF → ON after returning to the normal condition if the malfunction is detected again.

CONSULT display	Fail-safe	Tire pressure monitor warning lamp ON	Reference
U1000: CAN COMM	—	—	BCS-116
U1010: CONTROL UNIT (CAN)	—	—	BCS-117
B2190: NATS ANTENNA AMP	×	—	SEC-217
B2191: DIFFERENCE OF KEY	×	—	SEC-220
B2192: ID DISCORD BCM-ECM	×	—	SEC-221
B2193: CHAIN OF BCM-ECM	×	—	SEC-223
B2195: ANTI SCANNING	×	—	SEC-224
B2196: DONGLE NG	×	—	SEC-225
C1704: LOW PRESSURE FL	—	×	WT-16
C1705: LOW PRESSURE FR	—	×	
C1706: LOW PRESSURE RR	—	×	
C1707: LOW PRESSURE RL	—	×	

BCM (BODY CONTROL MODULE)

< ECU DIAGNOSIS INFORMATION >

CONSULT display	Fail-safe	Tire pressure monitor warning lamp ON	Reference
C1708: [NO DATA] FL	—	×	WT-18
C1709: [NO DATA] FR	—	×	
C1710: [NO DATA] RR	—	×	
C1711: [NO DATA] RL	—	×	
C1712: [CHECKSUM ERR] FL	—	×	WT-21
C1713: [CHECKSUM ERR] FR	—	×	
C1714: [CHECKSUM ERR] RR	—	×	
C1715: [CHECKSUM ERR] RL	—	×	
C1716: [PRESS DATA ERR] FL	—	×	WT-24
C1717: [PRESS DATA ERR] FR	—	×	
C1718: [PRESS DATA ERR] RR	—	×	
C1719: [PRESS DATA ERR] RL	—	×	
C1720: [CODE ERR] FL	—	×	WT-26
C1721: [CODE ERR] FR	—	×	
C1722: [CODE ERR] RR	—	×	
C1723: [CODE ERR] RL	—	×	
C1724: [BATT VOLT LOW] FL	—	×	WT-29
C1725: [BATT VOLT LOW] FR	—	×	
C1726: [BATT VOLT LOW] RR	—	×	
C1727: [BATT VOLT LOW] RL	—	×	
C1729: VHCL SPEED SIG ERR	—	×	WT-32
C1734: CONTROL UNIT	—	×	WT-34
C1735: IGN CIRCUIT OPEN	—	—	BCS-118

IPDM E/R (INTELLIGENT POWER DISTRIBUTION MODULE ENGINE ROOM)

< ECU DIAGNOSIS INFORMATION >

IPDM E/R (INTELLIGENT POWER DISTRIBUTION MODULE ENGINE ROOM)

WITH INTELLIGENT KEY

WITH INTELLIGENT KEY : Reference Value

INFOID:000000005133239

VALUES ON THE DIAGNOSIS TOOL

Monitor Item	Condition		Value/Status
MOTOR FAN REQ	Engine idle speed	Changes depending on engine coolant temperature, air conditioner operation status, vehicle speed, etc.	1/2/3/4
AC COMP REQ	Engine running	A/C switch OFF	Off
		A/C switch ON (Compressor is operating)	On
TAIL&CLR REQ	Lighting switch OFF		Off
	Lighting switch 1ST, 2ND, HI or AUTO (Light is illuminated)		On
HL LO REQ	Lighting switch OFF		Off
	Lighting switch 2ND, HI or AUTO (Light is illuminated)		On
HL HI REQ	Lighting switch OFF		Off
	Lighting switch HI		On
FR FOG REQ	Lighting switch 2ND or AUTO (Light is illuminated)	Front fog lamp switch OFF	Off
		Front fog lamp switch ON	On
FR WIP REQ	Ignition switch ON	Front wiper switch OFF	Stop
		Front wiper switch INT	1LOW
		Front wiper switch LO	Low
		Front wiper switch HI	Hi
WIP AUTO STOP	Ignition switch ON	Front wiper stop position	STOP P
		Any position other than front wiper stop position	ACT P
WIP PROT	Ignition switch ON	Front wiper operates normally	Off
		Front wiper stops at fail-safe operation	BLOCK
IGN RLY1 -REQ	Ignition switch OFF or ACC		Off
	Ignition switch ON		On
IGN RLY	Ignition switch OFF or ACC		Off
	Ignition switch ON		On
PUSH SW	Release the push-button ignition switch		Off
	Press the push-button ignition switch		On
INTER/NP SW	Ignition switch ON	<ul style="list-style-type: none"> Selector lever in any position other than P or N (CVT models) Release clutch pedal (M/T models) 	Off
		<ul style="list-style-type: none"> Selector lever in P or N position (CVT models) Depress clutch pedal (M/T models) 	On
ST RLY CONT	Ignition switch ON		Off
	At engine cranking		On

IPDM E/R (INTELLIGENT POWER DISTRIBUTION MODULE ENGINE ROOM)

< ECU DIAGNOSIS INFORMATION >

Monitor Item	Condition	Value/Status
IHBT RLY -REQ	Ignition switch ON	Off
	At engine cranking	On
ST/INHI RLY	Ignition switch ON	Off
	At engine cranking	INHI ON → ST ON
	The status of starter relay or starter control relay cannot be recognized by the battery voltage malfunction, etc. when the starter relay is ON and the starter control relay is OFF	UNKWN
DETENT SW	Ignition switch ON <ul style="list-style-type: none"> • Pull the selector lever with selector lever in P position • Selector lever in any position other than P 	Off
	Release the selector lever with selector lever in P position NOTE: Fixed On for M/T models	On
S/L RLY -REQ	None of the conditions below are present	Off
	<ul style="list-style-type: none"> • Open the driver door after the ignition switch is turned OFF (for a few seconds) • Press the push-button ignition switch when the steering lock is activated 	On
S/L STATE	Steering lock is activated	LOCK
	Steering lock is deactivated	UNLOCK
	[DTC: B210A] is detected	UNKWN
DTRL REQ NOTE: This item is monitored only on the vehicle with the daytime running light system.	Not operation	Off
	Daytime running light system is operated.	On
OIL P SW	Ignition switch OFF, ACC or engine running	Open
	Ignition switch ON	Close
HOOD SW	NOTE: The item is indicated, but not monitored.	Off
THFT HRN REQ	Not operation	Off
	<ul style="list-style-type: none"> • Panic alarm is activated • Horn is activated with VEHICLE SECURITY (THEFT WARNING) SYSTEM 	On
HORN CHIRP	Not operating	Off
	Door locking with Intelligent Key (horn chirp mode)	On

IPDM E/R (INTELLIGENT POWER DISTRIBUTION MODULE ENGINE ROOM)

< ECU DIAGNOSIS INFORMATION >

TERMINAL LAYOUT

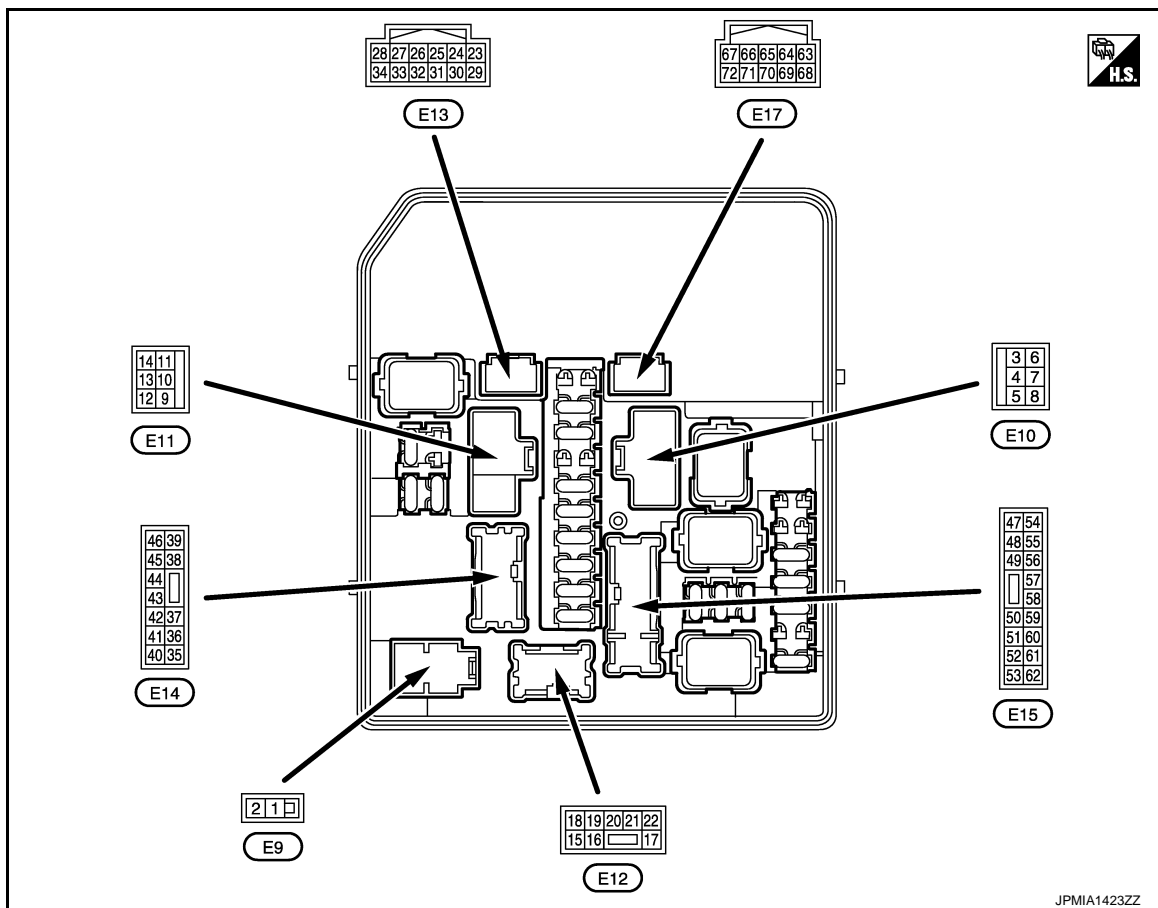

PHYSICAL VALUES

Terminal NO. (Wire color)		Description		Condition	Value (Approx.)
+	-	Signal name	Input/ Output		
1 (R)	Ground	Battery power supply	Input	Ignition switch OFF	Battery voltage
2 (G)	Ground	Battery power supply	Input	Ignition switch OFF	Battery voltage
3 (BR)	Ground	Starter motor	Output	Ignition switch ON	0 V
				At engine cranking	Battery voltage
4 (P)	Ground	Battery power supply	Input	Ignition switch OFF	Battery voltage
5 (LG)	Ground	Cooling fan relay-1 power supply	Output	Cooling fan OFF	0 V
				Cooling fan operated	Battery voltage
7 (Y)	Ground	Cooling fan relay-2 power supply	Output	Cooling fan OFF	0 V
				Cooling fan LO operated	9.0 V
				Cooling fan HI operated	Battery voltage
8 (V)	Ground	Battery power supply	Input	Ignition switch OFF	Battery voltage
9 (B/W)	Ground	Ground	—	Ignition switch ON	0 V
10 (L)	Ground	Cooling fan motor ground	Output	Cooling fan OFF	0 V
				Cooling fan LO operated	5.0 V
				Cooling fan HI operated	0 V

IPDM E/R (INTELLIGENT POWER DISTRIBUTION MODULE ENGINE ROOM)

< ECU DIAGNOSIS INFORMATION >

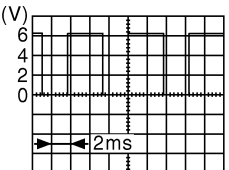
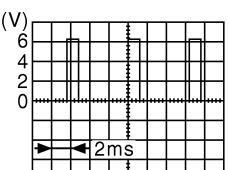
Terminal NO. (Wire color)		Description		Condition		Value (Approx.)
+	-	Signal name	Input/ Output			
13 (W)	Ground	Rear window defogger	Output	Ignition switch OFF	Rear window defogger switch OFF	0 V
				Ignition switch ON	Rear window defogger switch ON	Battery voltage
19 (B/W)	Ground	Ground	—	Ignition switch ON		0 V
21 (W)	Ground	Front fog lamp (RH)	Output	Lighting switch 2ND OFF	Front fog lamp switch OFF	0 V
				Lighting switch 2ND ON	Front fog lamp switch ON	Battery voltage
22 (V)	Ground	Front fog lamp (LH)	Output	Lighting switch 2ND OFF	Front fog lamp switch OFF	0 V
				Lighting switch 2ND ON	Front fog lamp switch ON	Battery voltage
24 (G)	Ground	Oil pressure switch	Input	Ignition switch ON	Engine stopped	0 V
				Ignition switch ON	Engine running	Battery voltage
25 (Y)	Ground	Front wiper auto stop	Input	Ignition switch ON	Front wiper stop position	0 V
				Ignition switch ON	Any position other than front wiper stop position	Battery voltage
26 (P)	Ground	CAN-L	Input/ Output	—		—
27 (L)	Ground	CAN-H	Input/ Output	—		—
28*1 (P)	Ground	Daytime running light relay-1 control	Output	Daytime running light deactivated		0 V
				Daytime running light activated		Battery voltage
30 (SB)	Ground	Starter relay control	Output	At engine cranking		0 V
				Ignition switch ON		Battery voltage
31 (W)	Ground	Fuel pump relay control	Output	<ul style="list-style-type: none"> • Approximately 1 second after turning the ignition switch ON • Engine running 		0 - 1.5 V
				Approximately 1 second or more after turning the ignition switch ON		Battery voltage
33 (O)	Ground	Power generation command signal	Output	Ignition switch ON		Battery voltage
				40 % is set on "ACTIVE TEST", "ALTERNATOR DUTY" of "ENGINE"		 <p style="text-align: right;">JPMA0002GB</p>
				80 % is set on "ACTIVE TEST", "ALTERNATOR DUTY" of "ENGINE"		 <p style="text-align: right;">JPMA0003GB</p>

IPDM E/R (INTELLIGENT POWER DISTRIBUTION MODULE ENGINE ROOM)

< ECU DIAGNOSIS INFORMATION >

Terminal NO. (Wire color)		Description		Condition	Value (Approx.)		
+	-	Signal name	Input/ Output				
34 (R)	Ground	Horn relay control	Output	The horn is deactivated	Battery voltage	A	
				The horn is activated	0 V	B	
36 (O)	Ground	Parking lamp (LH)	Output	Ignition switch ON	0 V	C	
				Lighting switch OFF	Battery voltage		
37 (V)	Ground	Parking lamp (RH)	Output	Ignition switch ON	0 V	D	
				Lighting switch OFF	Battery voltage		
38 (G)	Ground	Tail lamp (RH) & illuminations	Output	Ignition switch ON	0 V	E	
				Lighting switch OFF	Battery voltage		
39 (V)	Ground	Front wiper HI	Output	Ignition switch ON	0 V	F	
				Lighting switch OFF	Battery voltage		
40 (R)	Ground	ECM relay control	Output	Ignition switch OFF (More than a few seconds after turning ignition switch OFF)	Battery voltage	G	
				<ul style="list-style-type: none"> Ignition switch ON Ignition switch OFF (For a few seconds after turning ignition switch OFF) 	0 - 1.5 V	H	
41 (SB)	Ground	Tail lamp (LH) & license plate lamps	Output	Ignition switch ON	0 V	I	
				Lighting switch OFF	Battery voltage		
42 (W)	Ground	Steering lock unit power supply	Output	Ignition switch ACC or ON	0 V	J	
				Ignition switch ON	A few seconds after opening the driver door	Battery voltage	
				Ignition switch LOCK	Press the push-button ignition switch	Battery voltage	K
43 (G)	Ground	ECM relay power supply	Output	Ignition switch OFF (More than a few seconds after turning ignition switch OFF)	0 V	DEF	
				<ul style="list-style-type: none"> Ignition switch ON Ignition switch OFF (For a few seconds after turning ignition switch OFF) 	Battery voltage	M	
44 (P)	Ground	ECM relay power supply	Output	Ignition switch OFF (More than a few seconds after turning ignition switch OFF)	0 V	N	
				<ul style="list-style-type: none"> Ignition switch ON Ignition switch OFF (For a few seconds after turning ignition switch OFF) 	Battery voltage	O	
45 (Y)	Ground	TCM power supply	Output	Ignition switch OFF	Battery voltage	P	
46 (O)	Ground	Front wiper LO	Output	Ignition switch ON	0 V		
				Front wiper switch OFF	Battery voltage		

IPDM E/R (INTELLIGENT POWER DISTRIBUTION MODULE ENGINE ROOM)

< ECU DIAGNOSIS INFORMATION >

Terminal NO. (Wire color)		Description		Condition		Value (Approx.)
+	-	Signal name	Input/ Output			
47 (BR)	Ground	Transmission range switch ^{*2}	Input	Select lever in any position other than P or N (Ignition switch ON)		0 V
				Select lever P or N (Ignition switch ON)		Battery voltage
		Clutch interlockk switch ^{*3}		Release the clutch pedal		0 V
				Depress the clutch pedal		Battery voltage
49 (W)	Ground	Headlamp HI (RH)	Output	Ignition switch ON	Lighting switch OFF	0 V
					<ul style="list-style-type: none"> Lighting switch HI Lighting switch PASS 	Battery voltage
				Daytime running light activated ^{*1}		7.0 V
50 (GR)	Ground	Headlamp HI (LH)	Output	Ignition switch ON	Lighting switch OFF	0 V
					<ul style="list-style-type: none"> Lighting switch HI Lighting switch PASS 	Battery voltage
				Daytime running light activated ^{*1}		7.0 V
51 (R)	Ground	Headlamp LO (LH)	Output	Ignition switch ON	Lighting switch OFF	0 V
					Lighting switch 2ND	Battery voltage
52 (P)	Ground	Headlamp LO (RH)	Output	Ignition switch ON	Lighting switch OFF	0 V
		Daytime running light relay-2 ^{*1}			Lighting switch 2ND	Battery voltage
54 (GR)	Ground	Throttle control motor relay power supply	Output	Ignition switch OFF (More than a few seconds after turning ignition switch OFF)		0 V
				<ul style="list-style-type: none"> Ignition switch ON Ignition switch OFF (For a few seconds after turning ignition switch OFF) 		Battery voltage
55 (P)	Ground	Fuel pump power supply	Output	Approximately 1 second or more than after turning the ignition switch ON		0 V
				<ul style="list-style-type: none"> Approximately 1 second after turning the ignition switch ON Engine running 		Battery voltage
56 (SB)	Ground	A/C relay power supply	Output	Engine running	A/C switch OFF	0 V
					A/C switch ON (A/C compressor is operating)	Battery voltage
57 (G)	Ground	Throttle control motor relay control	Output	Ignition switch ON → OFF		0 - 1.0 V ↓ Battery voltage ↓ 0 V
				Ignition switch ON		0 - 1.0 V
58 (R) ^{*2} (Y) ^{*3}	Ground	Ignition relay power supply	Output	Ignition switch OFF		0 V
				Ignition switch ON		Battery voltage
59 (Y)	Ground	Ignition relay power supply	Output	Ignition switch OFF		0 V
				Ignition switch ON		Battery voltage
60 (V)	Ground	Ignition relay power supply	Output	Ignition switch OFF		0 V
				Ignition switch ON		Battery voltage

IPDM E/R (INTELLIGENT POWER DISTRIBUTION MODULE ENGINE ROOM)

< ECU DIAGNOSIS INFORMATION >

Terminal NO. (Wire color)		Description		Condition		Value (Approx.)
+	-	Signal name	Input/ Output			
61 (W)	Ground	Ignition relay power supply	Output	Ignition switch OFF		0 V
				Ignition switch ON		Battery voltage
62 (L)	Ground	Ignition relay power supply	Output	Ignition switch OFF		0 V
				Ignition switch ON		Battery voltage
64*2 (R)	Ground	CVT shift selector (Detention switch)	Input	Ignition switch ON	Select lever P	0 V
					Select lever in any position other than P	Battery voltage
65 (Y)	Ground	Steering lock unit condition-1	Input	Steering lock is activated		0 V
				Steering lock is deactivated		Battery voltage
66 (L)	Ground	Push-button ignition switch	Input	Press the push-button ignition switch		0 V
				Release the push-button ignition switch		Battery voltage
68 (W)	Ground	Steering lock unit condition-2	Input	Steering lock is activated		Battery voltage
				Steering lock is deactivated		0 V
69 (O)	Ground	Ignition relay monitor	Input	Ignition switch OFF or ACC		Battery voltage
				Ignition switch ON		0 V

*1: With daytime running light system

*2: CVT models

*3: M/T models

A
B
C
D
E
F
G
H
I
J
K
DEF
M
N
O
P



IPDM E/R (INTELLIGENT POWER DISTRIBUTION MODULE ENGINE ROOM)

< ECU DIAGNOSIS INFORMATION >

WITH INTELLIGENT KEY : Wiring Diagram — IPDM E/R —

INFOID:000000005133240

IPDM E/R (INTELLIGENT POWER DISTRIBUTION MODULE ENGINE ROOM) (WITH INTELLIGENT KEY)

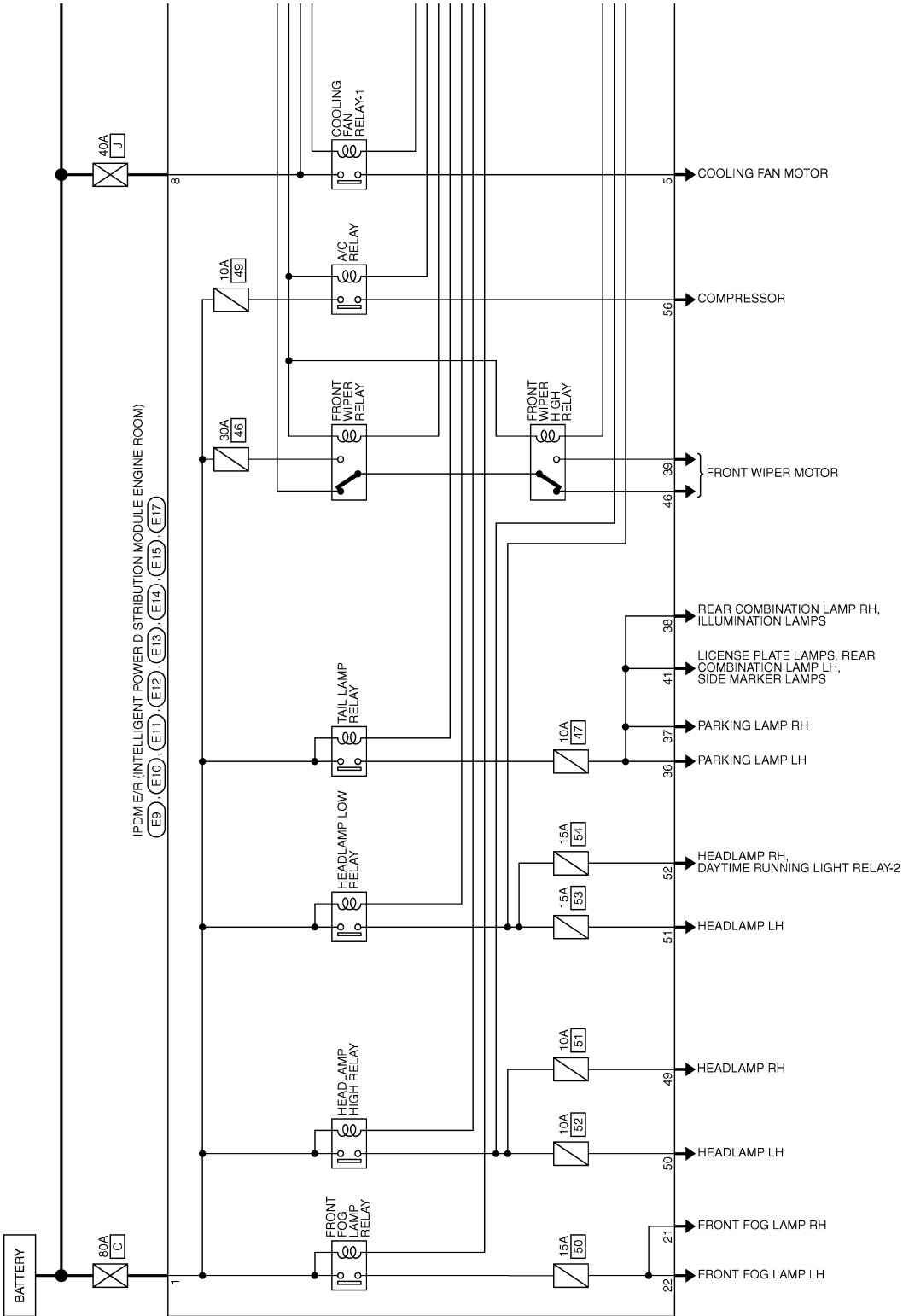

2009/02/27

JCMWM4080GB

IPDM E/R (INTELLIGENT POWER DISTRIBUTION MODULE ENGINE ROOM)

< ECU DIAGNOSIS INFORMATION >

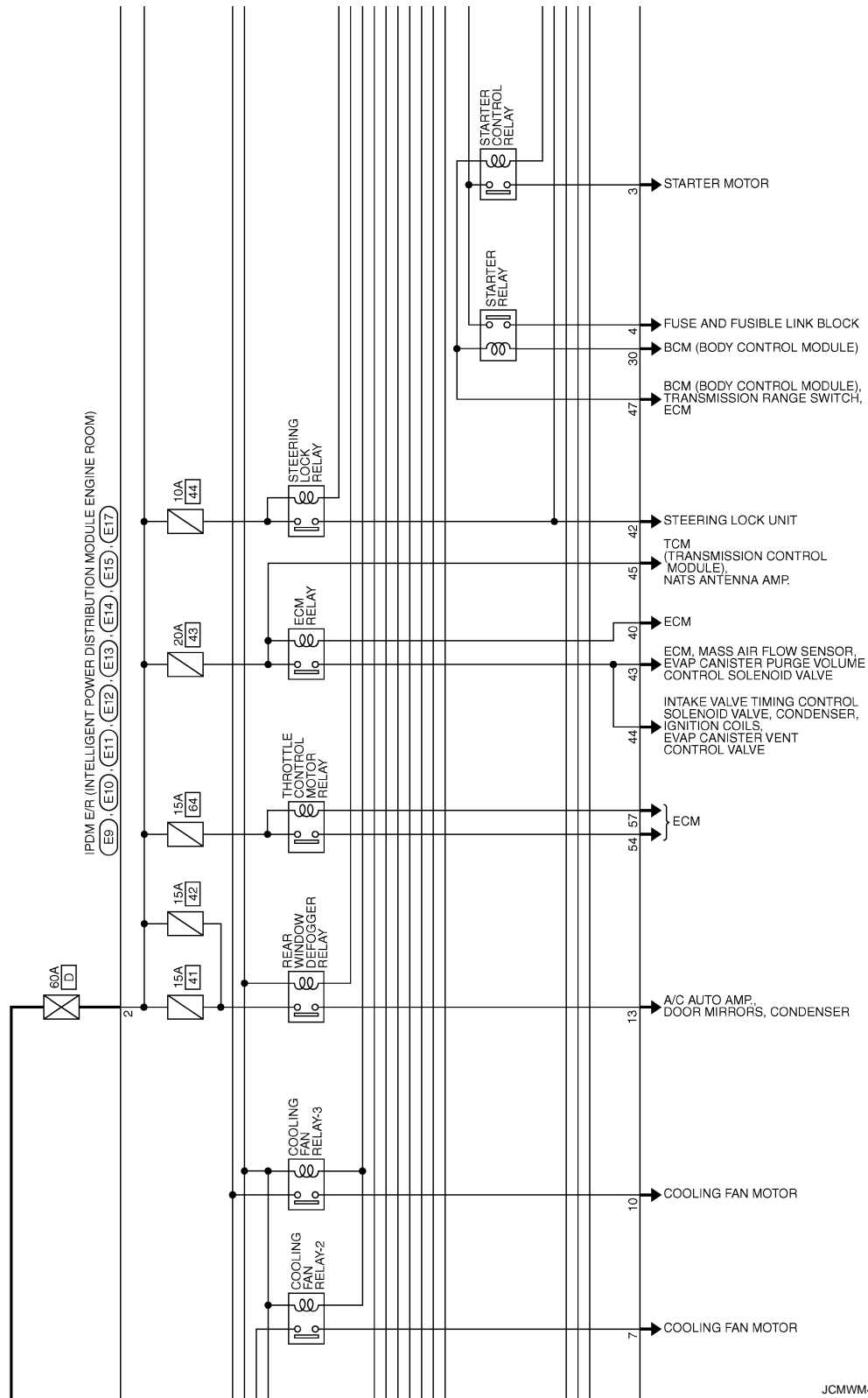

JCMWM4081GB

A
B
C
D
E
F
G
H
I
J
K
DEF
M
N
O
P

IPDM E/R (INTELLIGENT POWER DISTRIBUTION MODULE ENGINE ROOM)

< ECU DIAGNOSIS INFORMATION >

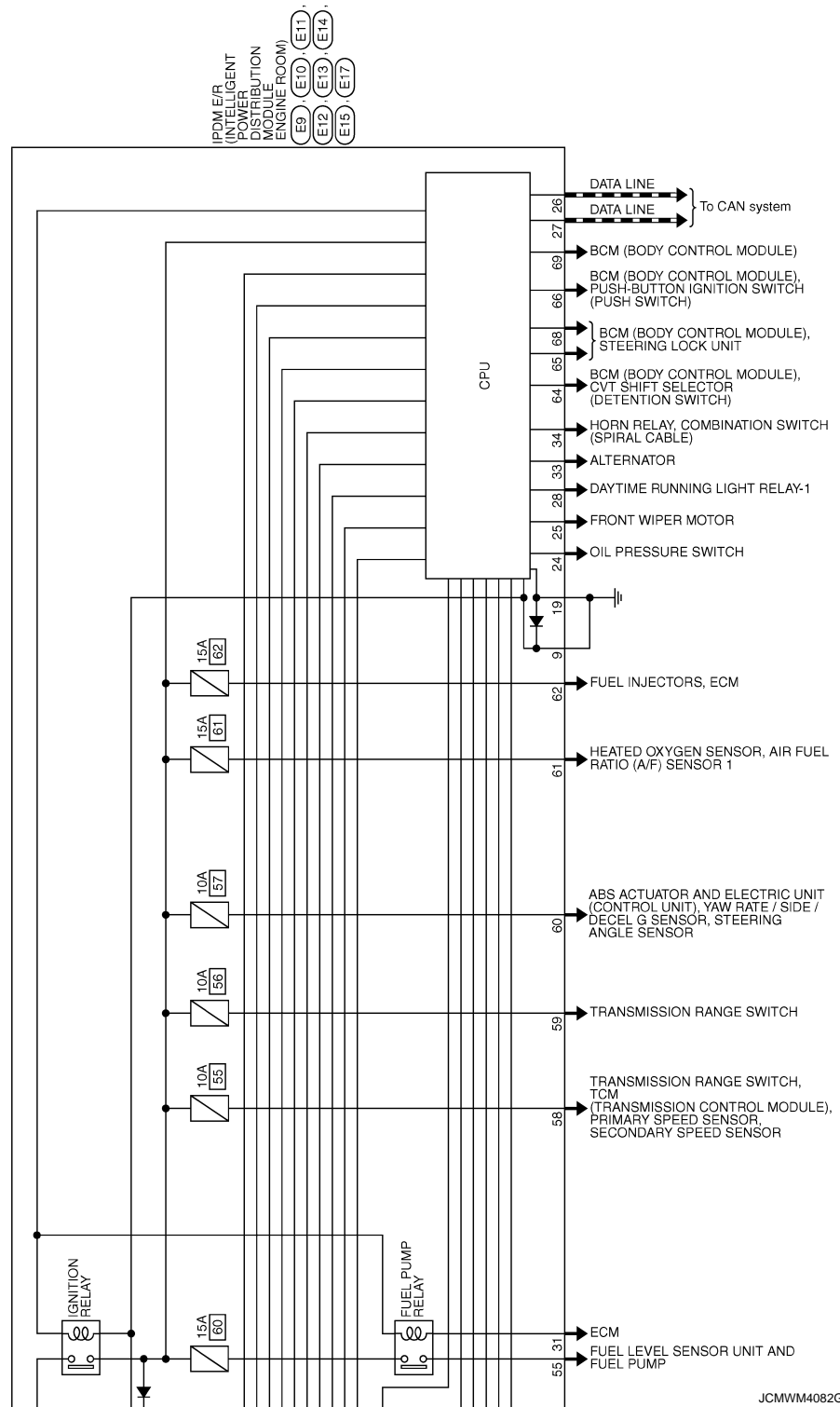

IPDM E/R (INTELLIGENT POWER DISTRIBUTION MODULE ENGINE ROOM)

< ECU DIAGNOSIS INFORMATION >

IPDM E/R (INTELLIGENT POWER DISTRIBUTION MODULE ENGINE ROOM) (WITH INTELLIGENT KEY)

Connector No.	E12
Connector Name	IPDM E/R (INTELLIGENT POWER DISTRIBUTION MODULE ENGINE ROOM)
Connector Type	NS33FBR-CS



22	21	19	18
----	----	----	----

Terminal No.	Color of Wire	Signal Name [Specification]
19	B/W	-
21	W	-
22	V	-

Connector No.	E11
Connector Name	IPDM E/R (INTELLIGENT POWER DISTRIBUTION MODULE ENGINE ROOM)
Connector Type	MSDFE-LC



10	9
13	

Terminal No.	Color of Wire	Signal Name [Specification]
9	B/W	-
10	L	-
13	W	-

Connector No.	E10
Connector Name	IPDM E/R (INTELLIGENT POWER DISTRIBUTION MODULE ENGINE ROOM)
Connector Type	MSDFW-LC



5	4	3
8	7	6

Terminal No.	Color of Wire	Signal Name [Specification]
3	BR	-
4	P	-
5	LG	-
7	Y	-
8	V	-

Connector No.	E9
Connector Name	IPDM E/R (INTELLIGENT POWER DISTRIBUTION MODULE ENGINE ROOM)
Connector Type	LC2FE-MC



1	2
---	---

Terminal No.	Color of Wire	Signal Name [Specification]
1	R	-
2	G	-

Connector No.	E15
Connector Name	IPDM E/R (INTELLIGENT POWER DISTRIBUTION MODULE ENGINE ROOM)
Connector Type	NS18FW-CS



52	51	50	49	47				
62	61	60	59	58	57	56	55	54

Terminal No.	Color of Wire	Signal Name [Specification]
60	V	-
61	W	-
62	L	-

Connector No.	E14
Connector Name	IPDM E/R (INTELLIGENT POWER DISTRIBUTION MODULE ENGINE ROOM)
Connector Type	NS12FBR-CS



39	38	37	36			
46	45	44	43	42	41	40

Connector No.	E13
Connector Name	IPDM E/R (INTELLIGENT POWER DISTRIBUTION MODULE ENGINE ROOM)
Connector Type	TH12FW-NH



28	27	26	25	24
34	33	31	30	

Terminal No.	Color of Wire	Signal Name [Specification]
39	O	-
37	V	-
38	G	-
39	V	-
40	R	-
41	SB	-
42	W	-
43	G	-
44	P	-
45	Y	-
46	O	-

Terminal No.	Color of Wire	Signal Name [Specification]
47	BR	-
49	W	-
50	GR	-
51	R	-
52	P	-
54	GR	-
55	P	-
56	SB	-
57	G	-
58	R	-
59	Y	-

Terminal No.	Color of Wire	Signal Name [Specification]
36	O	-
37	V	-
38	G	-
39	V	-
40	R	-
41	SB	-
42	W	-
43	G	-
44	P	-
45	Y	-
46	O	-

Terminal No.	Color of Wire	Signal Name [Specification]
24	G	-
25	Y	-
26	P	-
27	L	-
28	P	-
30	SB	-
31	W	-
33	O	-
34	R	-

JCMWM4083GB

A
B
C
D
E
F
G
H
I
J
K
DEF
M
N
O
P

IPDM E/R (INTELLIGENT POWER DISTRIBUTION MODULE ENGINE ROOM) (WITH INTELLIGENT KEY)

Connector No.	E17
Connector Name	IPDM E/R (INTELLIGENT POWER DISTRIBUTION MODULE ENGINE ROOM)
Connector Type	TH10FB-NH

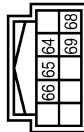

Terminal No.	Color of Wire	Signal Name [Specification]
64	R	-
65	Y	-
66	L	-
68	W	-
68	O	-

JCMWM4084GB

INFOID:000000005133241

WITH INTELLIGENT KEY : Fail-Safe

CAN COMMUNICATION CONTROL

When CAN communication with ECM and BCM is impossible, IPDM E/R performs fail-safe control. After CAN communication recovers normally, it also returns to normal control.

If No CAN Communication Is Available With ECM

IPDM E/R (INTELLIGENT POWER DISTRIBUTION MODULE ENGINE ROOM)

< ECU DIAGNOSIS INFORMATION >

Control part	Fail-safe operation
Cooling fan	<ul style="list-style-type: none"> The cooling fan relay-1, the cooling fan relay-2 and the cooling fan relay-3 turn ON when the ignition switch is turned ON (Cooling fan HI operation) The cooling fan relay-1, the cooling fan relay-2 and the cooling fan relay-3 turn OFF when the ignition switch is turned OFF
A/C compressor	A/C relay OFF
Alternator	Outputs the power generation command signal (PWM signal) 0%

If No CAN Communication Is Available With BCM

Control part	Fail-safe operation
Headlamp	<ul style="list-style-type: none"> Turns ON the headlamp low relay when the ignition switch is turned ON Turns OFF the headlamp low relay when the ignition switch is turned OFF Headlamp high relay OFF Daytime running light relay OFF*
<ul style="list-style-type: none"> Parking lamps Side marker lamps License plate lamps Illuminations Tail lamps 	<ul style="list-style-type: none"> Turns ON the tail lamp relay when the ignition switch is turned ON Turns OFF the tail lamp relay when the ignition switch is turned OFF
Front wiper	<ul style="list-style-type: none"> The status just before activation of fail-safe control is maintained until the ignition switch is turned OFF while the front wiper is operating at LO or HI speed. The wiper is operated at LO speed until the ignition switch is turned OFF if the fail-safe control is activated while the front wiper is set in the INT mode and the front wiper motor is operating.
Front fog lamps	Front fog lamp relay OFF
Horn	Horn OFF
Ignition relay	The status just before activation of fail-safe is maintained.
Starter motor	Starter control relay OFF
Steering lock unit	Steering lock relay OFF

*: With daytime running light system

IGNITION RELAY MALFUNCTION DETECTION FUNCTION

- IPDM E/R monitors the voltage at the contact circuit and excitation coil circuit of the ignition relay inside it.
- IPDM E/R judges the ignition relay error if the voltage differs between the contact circuit and the excitation coil circuit.
- If the ignition relay cannot turn OFF due to contact seizure, it activates the tail lamp relay for 10 minutes to alert the user to the ignition relay malfunction when the ignition switch is turned OFF.

Voltage judgment		IPDM E/R judgment	Operation
Ignition relay contact side	Ignition relay excitation coil side		
ON	ON	Ignition relay ON normal	—
OFF	OFF	Ignition relay OFF normal	—
ON	OFF	Ignition relay ON stuck	<ul style="list-style-type: none"> Detects DTC "B2098: IGN RELAY ON" Turns ON the tail lamp relay for 10 minutes
OFF	ON	Ignition relay OFF stuck	Detects DTC "B2099: IGN RELAY OFF"

FRONT WIPER CONTROL

IPDM E/R detects front wiper stop position by a front wiper stop position signal. When a front wiper stop position signal is in the conditions listed below, IPDM E/R stops power supply to wiper after repeating a front wiper 10 seconds activation and 20 seconds stop five times.

IPDM E/R (INTELLIGENT POWER DISTRIBUTION MODULE ENGINE ROOM)

< ECU DIAGNOSIS INFORMATION >

Ignition switch	Front wiper switch	Front wiper stop position signal
ON	OFF	The front wiper stop position signal (stop position) cannot be input for 10 seconds.
	ON	The front wiper stop position signal does not change for 10 seconds.

NOTE:

This operation status can be confirmed on the IPDM E/R “Data Monitor” that displays “BLOCK” for the item “WIP PROT” while the wiper is stopped.

STARTER MOTOR PROTECTION FUNCTION

IPDM E/R turns OFF the starter control relay to protect the starter motor when the starter control relay remains active for 90 seconds.

WITH INTELLIGENT KEY : DTC Index

INFOID:000000005133242

NOTE:

- The details of time display are as follows.
 - CRNT: A malfunction is detected now.
 - PAST: A malfunction was detected in the past.
- IGN counter is displayed on FFD (Freeze Frame data).
 - The number is 0 when is detected now.
 - The number increases like 1 → 2 ... 38 → 39 after returning to the normal condition whenever IGN OFF → ON.
 - The number is fixed to 39 until the self-diagnosis results are erased if it is over 39.

×: Applicable

CONSULT display	Fail-safe	Refer to
No DTC is detected. further testing may be required.	—	—
U1000: CAN COMM CIRCUIT	×	PCS-16
B2098: IGN RELAY ON	×	PCS-17
B2099: IGN RELAY OFF	—	PCS-18
B2108: STRG LCK RELAY ON	—	SEC-96
B2109: STRG LCK RELAY OFF	—	SEC-97
B210A: STRG LCK STATE SW	—	SEC-98
B210B: START CONT RLY ON	—	SEC-101
B210C: START CONT RLY OFF	—	SEC-102
B210D: STARTER RELAY ON	—	SEC-103
B210E: STARTER RELAY OFF	—	SEC-104
B210F: INTRLCK/PNP SW ON	—	SEC-106
B2110: INTRLCK/PNP SW OFF	—	SEC-108

WITHOUT INTELLIGENT KEY

WITHOUT INTELLIGENT KEY : Reference Value

INFOID:000000005133243

VALUES ON THE DIAGNOSIS TOOL

Monitor Item	Condition		Value/Status
MOTOR FAN REQ	Engine idle speed	Changes depending on engine coolant temperature, air conditioner operation status, vehicle speed, etc.	1/2/3/4

IPDM E/R (INTELLIGENT POWER DISTRIBUTION MODULE ENGINE ROOM)

< ECU DIAGNOSIS INFORMATION >

Monitor Item	Condition		Value/Status	
AC COMP REQ	Engine running	A/C switch OFF	Off	A
		A/C switch ON (Compressor is operating)	On	
TAIL&CLR REQ	Lighting switch OFF		Off	B
	Lighting switch 1ST, 2ND, HI or AUTO (Light is illuminated)		On	
HL LO REQ	Lighting switch OFF		Off	C
	Lighting switch 2ND, HI or AUTO (Light is illuminated)		On	
HL HI REQ	Lighting switch OFF		Off	D
	Lighting switch HI		On	
FR FOG REQ	Lighting switch 2ND or AUTO (Light is illuminated)	Front fog lamp switch OFF	Off	
		Front fog lamp switch ON	On	E
FR WIP REQ	Ignition switch ON	Front wiper switch OFF	Stop	
		Front wiper switch INT	1LOW	F
		Front wiper switch LO	Low	
		Front wiper switch HI	Hi	
WIP AUTO STOP	Ignition switch ON	Front wiper stop position	STOP P	G
		Any position other than front wiper stop position	ACT P	
WIP PROT	Ignition switch ON	Front wiper operates normally	Off	H
		Front wiper stops at fail-safe opera- tion	BLOCK	
IGN RLY	Ignition switch OFF or ACC		Off	I
	Ignition switch ON		On	
INTER/NP SW	Ignition switch ON	Selector lever in any position other than P or N (CVT models)	Off	J
		Selector lever in P or N position (CVT models)	On	
ST RLY -REQ	Ignition switch OFF or ACC		Off	K
	Ignition switch ON		On	
DTRL REQ NOTE: This item is monitored only on the vehicle with the daytime running light system.	Not operation		Off	DEF
	Daytime running light system is operated.		On	
OIL P SW	Ignition switch OFF, ACC or engine running		Open	M
	Ignition switch ON		Close	
HOOD SW	NOTE: The item is indicated, but not monitored.		Off	N
THFT HRN REQ	Not operation		Off	O
	<ul style="list-style-type: none"> Panic alarm is activated Horn is activated with VEHICLE SECURITY (THEFT WARNING) SYS- TEM 		On	
HORN CHIRP	Not operating		Off	P
	Door locking with key fob (horn chirp mode)		On	

IPDM E/R (INTELLIGENT POWER DISTRIBUTION MODULE ENGINE ROOM)

< ECU DIAGNOSIS INFORMATION >

TERMINAL LAYOUT

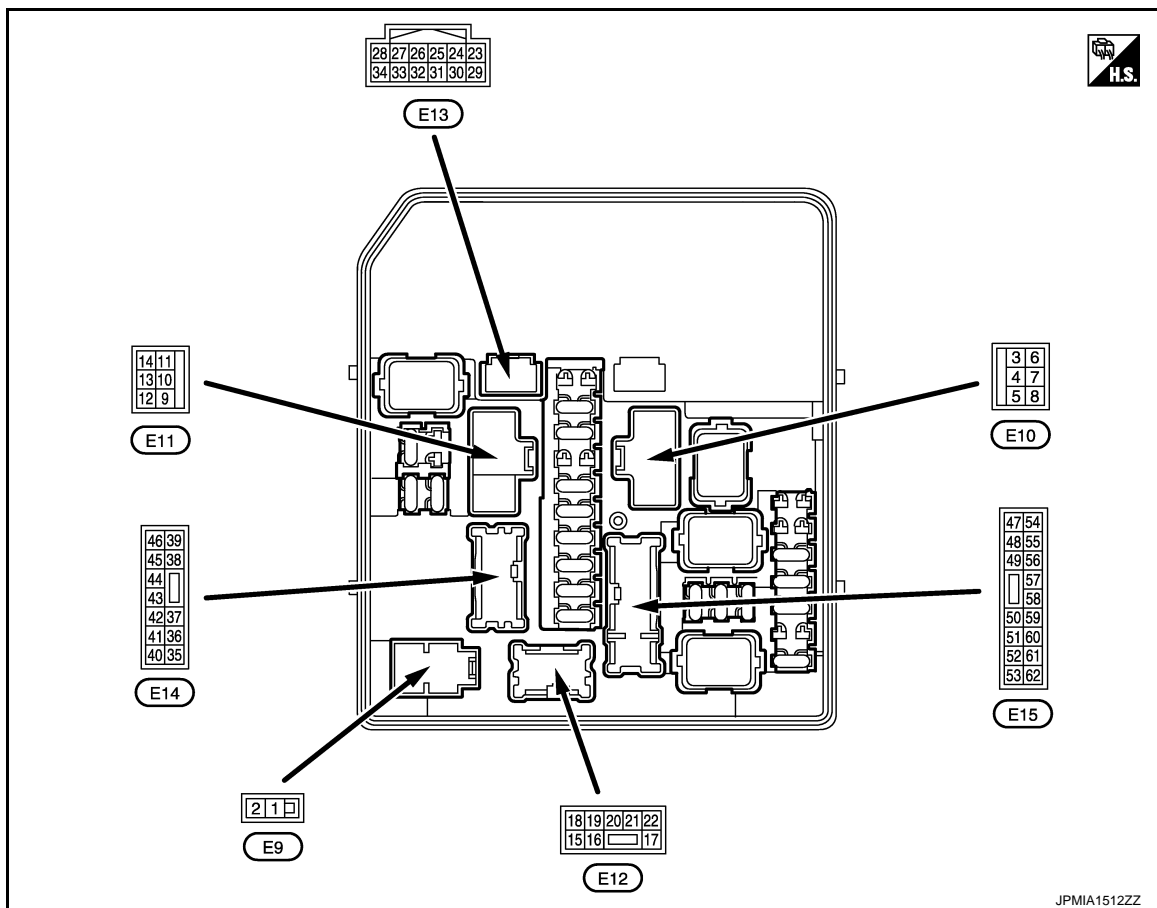

PHYSICAL VALUES

Terminal NO. (Wire color)		Description		Condition	Value (Approx.)
+	-	Signal name	Input/ Output		
1 (R)	Ground	Battery power supply	Input	Ignition switch OFF	Battery voltage
2 (G)	Ground	Battery power supply	Input	Ignition switch OFF	Battery voltage
3 (BR)	Ground	Starter motor	Output	Ignition switch ON	0 V
				At engine cranking	Battery voltage
5 (LG)	Ground	Cooling fan relay-1 power supply	Output	Cooling fan OFF	0 V
				Cooling fan operated	Battery voltage
6 (SB)	Ground	Ignition switch START	Output	Any position other ignition switch START	0 V
				Ignition switch START	Battery voltage
7 (Y)	Ground	Cooling fan relay-2 power supply	Output	Cooling fan OFF	0 V
				Cooling fan LO operated	9.0 V
				Cooling fan HI operated	Battery voltage
8 (V)	Ground	Battery power supply	Input	Ignition switch OFF	Battery voltage
9 (B/W)	Ground	Ground	—	Ignition switch ON	0 V

IPDM E/R (INTELLIGENT POWER DISTRIBUTION MODULE ENGINE ROOM)

< ECU DIAGNOSIS INFORMATION >

Terminal NO. (Wire color)		Description		Condition		Value (Approx.)
+	-	Signal name	Input/ Output			
10 (L)	Ground	Cooling fan motor ground	Output	Cooling fan OFF		0 V
				Cooling fan LO operated		5.0 V
				Cooling fan HI operated		0 V
13 (W)	Ground	Rear window defogger	Output	Ignition switch OFF	Rear window defogger switch OFF	0 V
				ON	Rear window defogger switch ON	Battery voltage
18 (Y)	Ground	Ignition switch	Output	Ignition switch OFF		0 V
				Ignition switch ON		Battery voltage
19 (B/W)	Ground	Ground	—	Ignition switch ON		0 V
21 (W)	Ground	Front fog lamp (RH)	Output	Lighting switch 2ND	Front fog lamp switch OFF	0 V
					Front fog lamp switch ON	Battery voltage
22 (V)	Ground	Front fog lamp (LH)	Output	Lighting switch 2ND	Front fog lamp switch OFF	0 V
					Front fog lamp switch ON	Battery voltage
24 (G)	Ground	Oil pressure switch	Input	Ignition switch ON	Engine stopped	0 V
					Engine running	Battery voltage
25 (Y)	Ground	Front wiper auto stop	Input	Ignition switch ON	Front wiper stop position	0 V
					Any position other than front wiper stop position	Battery voltage
26 (P)	Ground	CAN-L	Input/ Output	—		—
27 (L)	Ground	CAN-H	Input/ Output	—		—
28*1 (P)	Ground	Daytime running light relay-1 control	Output	Daytime running light deactivated		0 V
				Daytime running light activated		Battery voltage
31 (W)	Ground	Fuel pump relay control	Output	<ul style="list-style-type: none"> Approximately 1 second after turning the ignition switch ON Engine running 		0 - 1.5 V
				Approximately 1 second or more after turning the ignition switch ON		Battery voltage

A
B
C
D
E
F
G
H
I
J
K
DEF
M
N
O
P

IPDM E/R (INTELLIGENT POWER DISTRIBUTION MODULE ENGINE ROOM)

< ECU DIAGNOSIS INFORMATION >

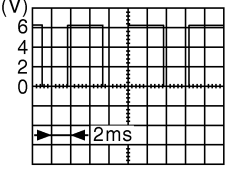
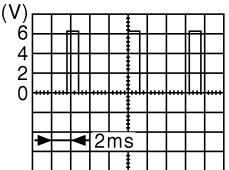
Terminal NO. (Wire color)		Description		Condition	Value (Approx.)	
+	-	Signal name	Input/ Output			
33 (O)	Ground	Power generation command signal	Output	Ignition switch ON	Battery voltage	
				40 % is set on "ACTIVE TEST", "ALTERNATOR DUTY" of "ENGINE"	 <p style="text-align: right;">JPMIA0002GB</p>	3.8 V
				80 % is set on "ACTIVE TEST", "ALTERNATOR DUTY" of "ENGINE"	 <p style="text-align: right;">JPMIA0003GB</p>	1.4 V
34 (R)	Ground	Horn relay control	Output	The horn is deactivated	Battery voltage	
				The horn is activated	0 V	
36 (O)	Ground	Parking lamp (LH)	Output	Ignition switch OFF	Lighting switch OFF	0 V
				Ignition switch ON	Lighting switch 1ST	Battery voltage
37 (V)	Ground	Parking lamp (RH)	Output	Ignition switch OFF	Lighting switch OFF	0 V
				Ignition switch ON	Lighting switch 1ST	Battery voltage
38 (G)	Ground	Tail lamp (RH) & illuminations	Output	Ignition switch OFF	Lighting switch OFF	0 V
				Ignition switch ON	Lighting switch 1ST	Battery voltage
39 (V)	Ground	Front wiper HI	Output	Ignition switch OFF	Front wiper switch OFF	0 V
				Ignition switch ON	Front wiper switch HI	Battery voltage
40 (R)	Ground	ECM relay control	Output	Ignition switch OFF (More than a few seconds after turning ignition switch OFF)	Battery voltage	
				<ul style="list-style-type: none"> Ignition switch ON Ignition switch OFF (For a few seconds after turning ignition switch OFF) 	0 - 1.5 V	
41 (SB)	Ground	Tail lamp (LH) & license plate lamps	Output	Ignition switch OFF	Lighting switch OFF	0 V
				Ignition switch ON	Lighting switch 1ST	Battery voltage
43 (G)	Ground	ECM relay power supply	Output	Ignition switch OFF (More than a few seconds after turning ignition switch OFF)	0 V	
				<ul style="list-style-type: none"> Ignition switch ON Ignition switch OFF (For a few seconds after turning ignition switch OFF) 	Battery voltage	

IPDM E/R (INTELLIGENT POWER DISTRIBUTION MODULE ENGINE ROOM)

< ECU DIAGNOSIS INFORMATION >

Terminal NO. (Wire color)		Description		Condition		Value (Approx.)		
+	-	Signal name	Input/ Output					
44 (P)	Ground			ECM relay power supply	Output			Ignition switch OFF (More than a few seconds after turning ignition switch OFF)
		<ul style="list-style-type: none"> Ignition switch ON Ignition switch OFF (For a few seconds after turning ignition switch OFF) 				Battery voltage	B	
45 (Y)	Ground	TCM power supply	Output	Ignition switch OFF		Battery voltage	C	
46 (O)	Ground	Front wiper LO	Output	Ignition switch ON	Front wiper switch OFF	0 V	D	
					Front wiper switch LO	Battery voltage	E	
47 (BR)	Ground	Transmission range switch ^{*2}	Input	Select lever in any position other than P or N (Ignition switch ON)		0 V	F	
				Select lever P or N (Ignition switch ON)		Battery voltage	G	
		Clutch interlock switch ^{*3}	Input	Release the clutch pedal		0 V	H	
				Depress the clutch pedal		Battery voltage	I	
49 (W)	Ground	Headlamp HI (RH)	Output	Ignition switch ON	Lighting switch OFF	0 V	J	
					<ul style="list-style-type: none"> Lighting switch HI Lighting switch PASS 		Battery voltage	K
					Daytime running light activated ^{*1}		7.0 V	L
50 (GR)	Ground	Headlamp HI (LH)	Output	Ignition switch ON	Lighting switch OFF	0 V	M	
					<ul style="list-style-type: none"> Lighting switch HI Lighting switch PASS 		Battery voltage	N
					Daytime running light activated ^{*1}		7.0 V	O
51 (R)	Ground	Headlamp LO (LH)	Output	Ignition switch ON	Lighting switch OFF	0 V	P	
					Lighting switch 2ND	Battery voltage		
52 (P)	Ground	Headlamp LO (RH)	Output	Ignition switch ON	Lighting switch OFF	0 V		
		Daytime running light relay-2 ^{*1}			Lighting switch 2ND	Battery voltage	DEF	
54 (GR)	Ground	Throttle control motor relay power supply	Output	Ignition switch OFF (More than a few seconds after turning ignition switch OFF)		0 V		
				<ul style="list-style-type: none"> Ignition switch ON Ignition switch OFF (For a few seconds after turning ignition switch OFF) 		Battery voltage		
55 (P)	Ground	Fuel pump power supply	Output	Approximately 1 second or more than after turning the ignition switch ON		0 V		
				<ul style="list-style-type: none"> Approximately 1 second after turning the ignition switch ON Engine running 		Battery voltage		
				Engine running	A/C switch OFF	0 V		
A/C switch ON (A/C compressor is operating)	Battery voltage							

IPDM E/R (INTELLIGENT POWER DISTRIBUTION MODULE ENGINE ROOM)

< ECU DIAGNOSIS INFORMATION >

Terminal NO. (Wire color)		Description		Condition	Value (Approx.)
+	-	Signal name	Input/ Output		
57 (G)	Ground	Throttle control motor relay control	Output	Ignition switch ON → OFF	0 - 1.0 V ↓ Battery voltage ↓ 0 V
				Ignition switch ON	0 - 1.0 V
58 (R) ^{*2} (Y) ^{*3}	Ground	Ignition relay power supply	Output	Ignition switch OFF	0 V
				Ignition switch ON	Battery voltage
59 (Y)	Ground	Ignition relay power supply	Output	Ignition switch OFF	0 V
				Ignition switch ON	Battery voltage
60 (V)	Ground	Ignition relay power supply	Output	Ignition switch OFF	0 V
				Ignition switch ON	Battery voltage
61 (W)	Ground	Ignition relay power supply	Output	Ignition switch OFF	0 V
				Ignition switch ON	Battery voltage
62 (L)	Ground	Ignition relay power supply	Output	Ignition switch OFF	0 V
				Ignition switch ON	Battery voltage

*1: With daytime running light system

*2: CVT models

*3: M/T models

IPDM E/R (INTELLIGENT POWER DISTRIBUTION MODULE ENGINE ROOM)

< ECU DIAGNOSIS INFORMATION >

WITHOUT INTELLIGENT KEY : Wiring Diagram — IPDM E/R —

INFOID:000000005133244

IPDM E/R (INTELLIGENT POWER DISTRIBUTION MODULE ENGINE ROOM) (WITHOUT INTELLIGENT KEY)

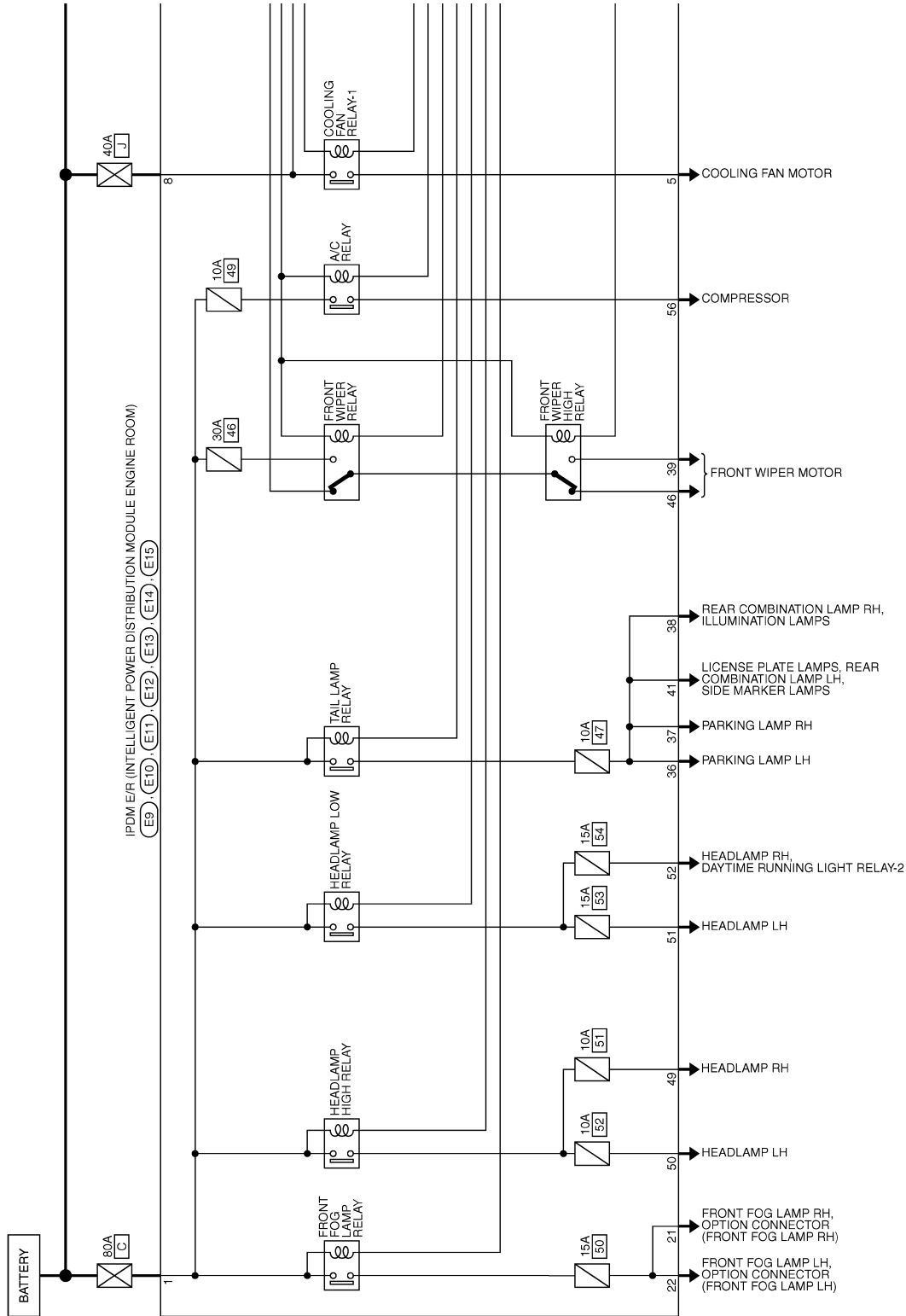

2009/02/27

JCMWM4085GB

A
B
C
D
E
F
G
H
I
J
K
DEF
M
N
O
P

IPDM E/R (INTELLIGENT POWER DISTRIBUTION MODULE ENGINE ROOM)

< ECU DIAGNOSIS INFORMATION >

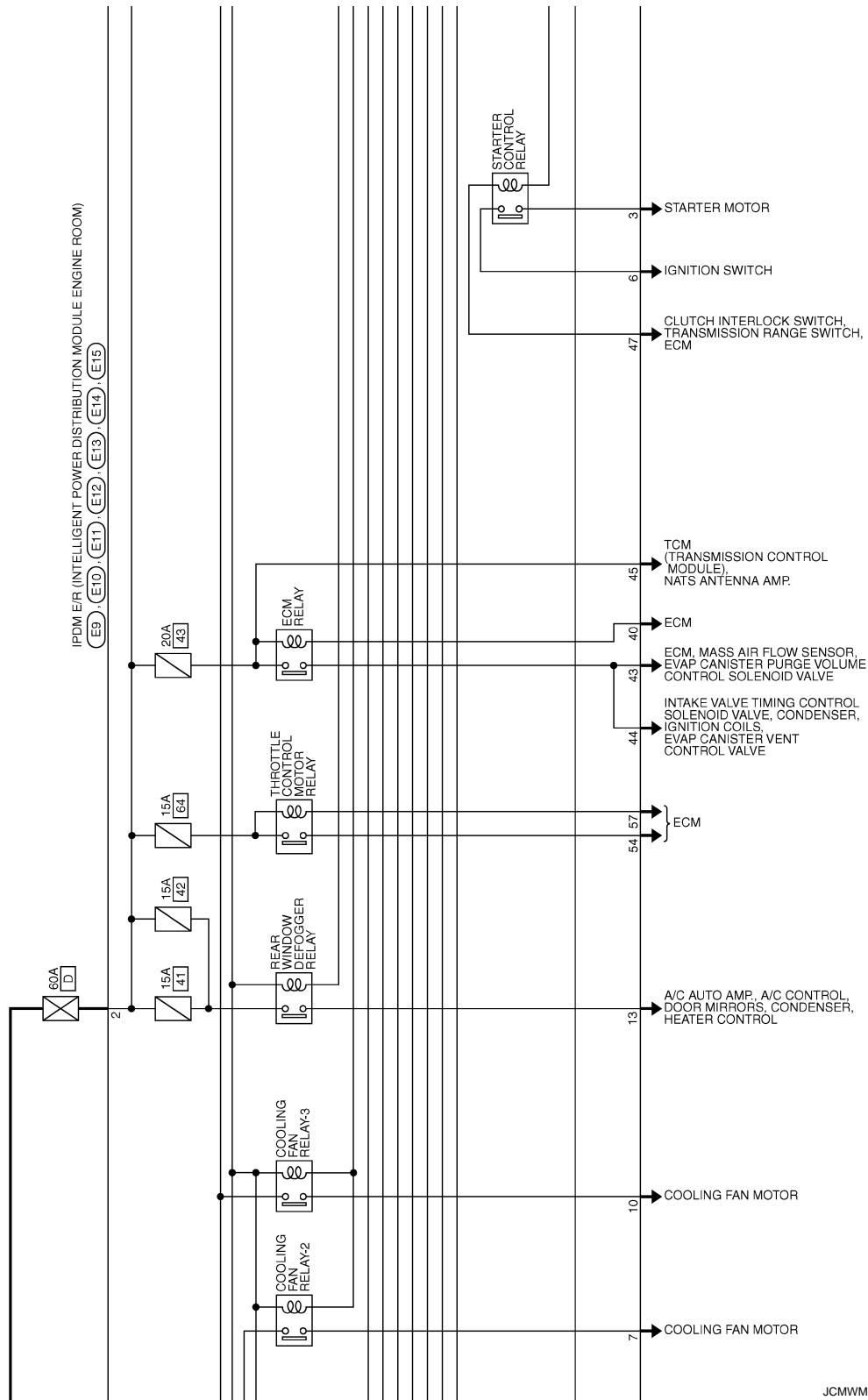

JCMWM4086GB

IPDM E/R (INTELLIGENT POWER DISTRIBUTION MODULE ENGINE ROOM)

< ECU DIAGNOSIS INFORMATION >

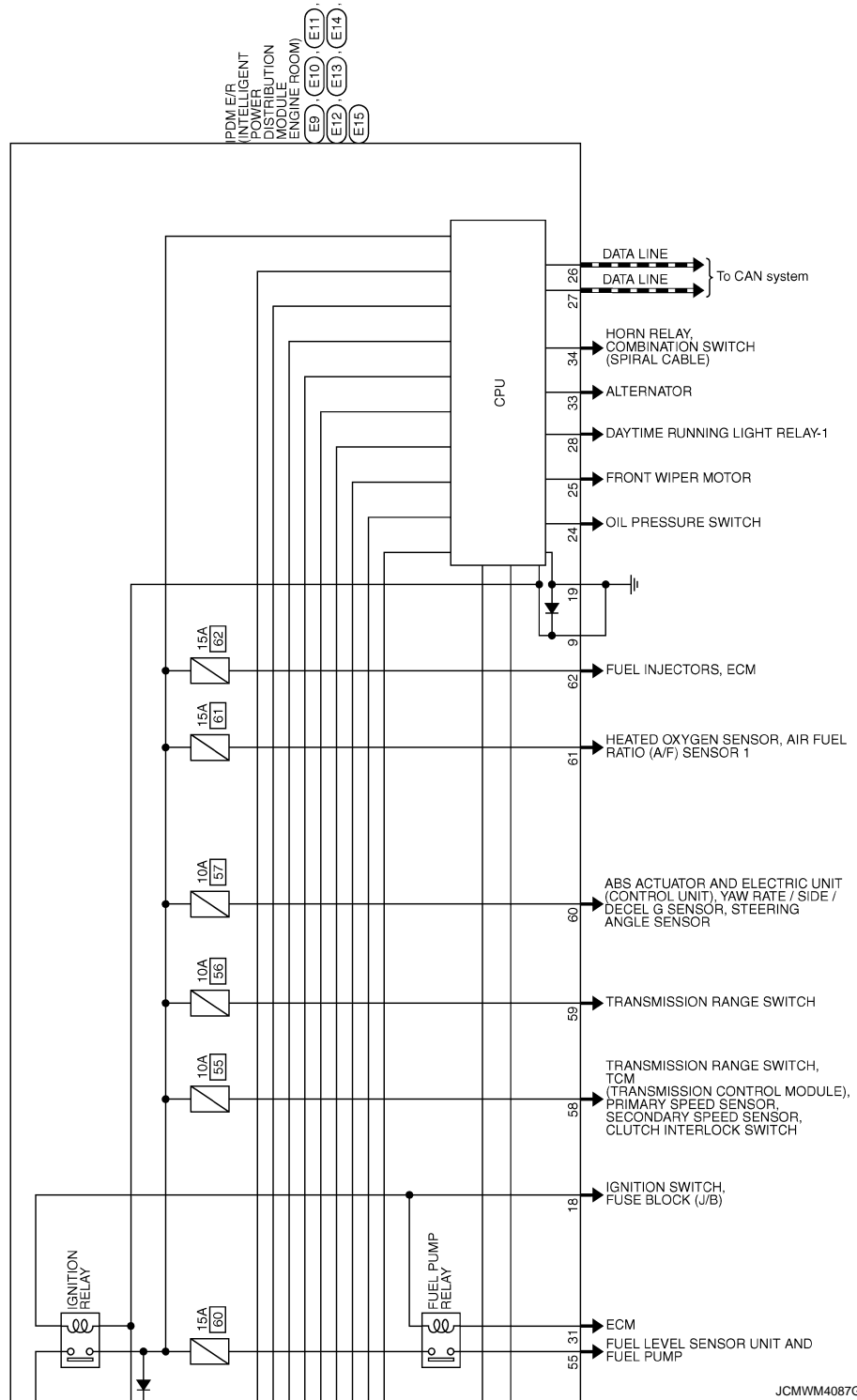

A
B
C
D
E
F
G
H
I
J
K
DEF
M
N
O
P

IPDM E/R (INTELLIGENT POWER DISTRIBUTION MODULE ENGINE ROOM)

< ECU DIAGNOSIS INFORMATION >

IPDM E/R (INTELLIGENT POWER DISTRIBUTION MODULE ENGINE ROOM) (WITHOUT INTELLIGENT KEY)			IPDM E/R (INTELLIGENT POWER DISTRIBUTION MODULE ENGINE ROOM)			IPDM E/R (INTELLIGENT POWER DISTRIBUTION MODULE ENGINE ROOM)			IPDM E/R (INTELLIGENT POWER DISTRIBUTION MODULE ENGINE ROOM)			IPDM E/R (INTELLIGENT POWER DISTRIBUTION MODULE ENGINE ROOM)			IPDM E/R (INTELLIGENT POWER DISTRIBUTION MODULE ENGINE ROOM)																													
Connector No.	Connector Name	Connector Type	Terminal No.	Color of Wire	Signal Name [Specification]	Terminal No.	Color of Wire	Signal Name [Specification]	Terminal No.	Color of Wire	Signal Name [Specification]	Terminal No.	Color of Wire	Signal Name [Specification]	Terminal No.	Color of Wire	Signal Name [Specification]																											
E9	IPDM E/R (INTELLIGENT POWER DISTRIBUTION MODULE ENGINE ROOM)	LS2FB-MC	1	R	-	3	BR	-	E10	IPDM E/R (INTELLIGENT POWER DISTRIBUTION MODULE ENGINE ROOM)	MS2FB-LC	5	LG	-	E11	IPDM E/R (INTELLIGENT POWER DISTRIBUTION MODULE ENGINE ROOM)	MS2FB-LC	9	B/W	-	E12	IPDM E/R (INTELLIGENT POWER DISTRIBUTION MODULE ENGINE ROOM)	MS2FB-GS	18	Y	-	E13	IPDM E/R (INTELLIGENT POWER DISTRIBUTION MODULE ENGINE ROOM)	TH12FB-NH	24	G	-	E14	IPDM E/R (INTELLIGENT POWER DISTRIBUTION MODULE ENGINE ROOM)	NS12FB-GS	36	O	-	E15	IPDM E/R (INTELLIGENT POWER DISTRIBUTION MODULE ENGINE ROOM)	NS18FW-GS	47	BR	-
2	-	-	G	-	-	5	LG	-	8	Y	-	6	SB	-	10	L	-	13	W	-	19	B/W	-	59	Y	-	60	V	-	61	W	-	62	L	-									
						7	Y	-	8	Y	-	8	Y	-	13	W	-	13	W	-	21	W	-	59	Y	-	60	V	-	61	W	-	62	L	-									
						8	Y	-	8	Y	-	8	Y	-	13	W	-	13	W	-	22	V	-	59	Y	-	60	V	-	61	W	-	62	L	-									

IPDM E/R (INTELLIGENT POWER DISTRIBUTION MODULE ENGINE ROOM)

< ECU DIAGNOSIS INFORMATION >

Control part	Fail-safe operation
Cooling fan	<ul style="list-style-type: none"> The cooling fan relay-1, the cooling fan relay-2 and the cooling fan relay-3 turn ON when the ignition switch is turned ON (Cooling fan HI operation) The cooling fan relay-1, the cooling fan relay-2 and the cooling fan relay-3 turn OFF when the ignition switch is turned OFF
A/C compressor	A/C relay OFF
Alternator	Outputs the power generation command signal (PWM signal) 0%

If No CAN Communication Is Available With BCM

Control part	Fail-safe operation
Headlamp	<ul style="list-style-type: none"> Turns ON the headlamp low relay when the ignition switch is turned ON Turns OFF the headlamp low relay when the ignition switch is turned OFF Headlamp high relay OFF Daytime running light relay OFF*
<ul style="list-style-type: none"> Parking lamps Side marker lamps License plate lamps Illuminations Tail lamps 	<ul style="list-style-type: none"> Turns ON the tail lamp relay when the ignition switch is turned ON Turns OFF the tail lamp relay when the ignition switch is turned OFF
Front wiper	<ul style="list-style-type: none"> The status just before activation of fail-safe control is maintained until the ignition switch is turned OFF while the front wiper is operating at LO or HI speed. The wiper is operated at LO speed until the ignition switch is turned OFF if the fail-safe control is activated while the front wiper is set in the INT mode and the front wiper motor is operating.
Front fog lamps	Front fog lamp relay OFF
Rear window defogger relay	Rear window defogger relay OFF
Horn	Horn OFF

*: With daytime running light system

IGNITION RELAY MALFUNCTION DETECTION FUNCTION

- IPDM E/R monitors the voltage at the contact circuit of the ignition relay inside and ignition switch status from BCM via CAN communication.
- IPDM E/R judges the ignition relay error if the voltage differs between the contact circuit and the ignition switch status from BCM via CAN communication.
- If the ignition relay cannot turn OFF due to contact seizure, it activates the tail lamp relay for 10 minutes to alert the user to the ignition relay malfunction when the ignition switch is turned OFF.

Voltage judgment		IPDM E/R judgment	Operation
Ignition relay contact side	Ignition switch status from BCM		
ON	ON	Ignition relay ON normal	—
OFF	OFF	Ignition relay OFF normal	—
ON	OFF	Ignition relay ON stuck	<ul style="list-style-type: none"> Detects DTC "B2098: IGN RELAY ON" Turns ON the tail lamp relay for 10 minutes
OFF	ON	Ignition relay OFF stuck	Detects DTC "B2099: IGN RELAY OFF"

FRONT WIPER CONTROL

IPDM E/R detects front wiper stop position by a front wiper stop position signal. When a front wiper stop position signal is in the conditions listed below, IPDM E/R stops power supply to wiper after repeating a front wiper 10 seconds activation and 20 seconds stop five times.

IPDM E/R (INTELLIGENT POWER DISTRIBUTION MODULE ENGINE ROOM)

< ECU DIAGNOSIS INFORMATION >

Ignition switch	Front wiper switch	Front wiper stop position signal
ON	OFF	The front wiper stop position signal (stop position) cannot be input for 10 seconds.
	ON	The front wiper stop position signal does not change for 10 seconds.

NOTE:

This operation status can be confirmed on the IPDM E/R “Data Monitor” that displays “BLOCK” for the item “WIP PROT” while the wiper is stopped.

WITHOUT INTELLIGENT KEY : DTC Index

INFOID:000000005133246

NOTE:

- The details of time display are as follows.
 - CRNT: A malfunction is detected now.
 - PAST: A malfunction was detected in the past.
- IGN counter is displayed on FFD (Freeze Frame data).
 - The number is 0 when is detected now.
 - The number increases like 1 → 2 ... 38 → 39 after returning to the normal condition whenever IGN OFF → ON.
 - The number is fixed to 39 until the self-diagnosis results are erased if it is over 39.

×: Applicable

CONSULT display	Fail-safe	Refer to
No DTC is detected. further testing may be required.	—	—
U1000: CAN COMM CIRCUIT	×	PCS-16
B2098: IGN RELAY ON	×	PCS-17
B2099: IGN RELAY OFF	—	PCS-49

REAR WINDOW DEFOGGER DOES NOT OPERATE

< SYMPTOM DIAGNOSIS >

SYMPTOM DIAGNOSIS

REAR WINDOW DEFOGGER DOES NOT OPERATE

Diagnosis Procedure

INFOID:000000005049323

1. CHECK POWER SUPPLY AND GROUND CIRCUIT

Check power supply and ground circuit.

- BCM with Intelligent Key system: Refer to [DEF-21, "BCM \(BODY CONTROL SYSTEM\) \(WITH INTELLIGENT KEY SYSTEM\) : Diagnosis Procedure"](#).
- BCM without Intelligent Key system: Refer to [DEF-21, "BCM \(BODY CONTROL SYSTEM\) \(WITHOUT INTELLIGENT KEY SYSTEM\) : Diagnosis Procedure"](#).
- IPDM E/R with Intelligent Key system: Refer to [DEF-22, "IPDM E/R \(WITH INTELLIGENT KEY SYSTEM\) : Diagnosis Procedure"](#).
- IPDM E/R without Intelligent Key system: Refer to [DEF-23, "IPDM E/R \(WITHOUT INTELLIGENT KEY SYSTEM\) : Diagnosis Procedure"](#).

Is the inspection result normal?

YES >> GO TO 2.

NO >> Repair or replace the malfunctioning parts.

2. CHECK REAR WINDOW DEFOGGER SWITCH

Check rear window defogger switch.

- Without A/C: Refer to [DEF-28, "WITHOUT A/C : Component Function Check"](#).
- Without auto A/C: Refer to [DEF-26, "WITHOUT AUTO A/C : Component Function Check"](#).
- With auto A/C: Refer to [DEF-25, "WITH AUTO A/C : Component Function Check"](#).

Is the inspection result normal?

YES >> GO TO 3.

NO >> Repair or replace the malfunctioning parts.

3. CHECK REAR WINDOW DEFOGGER RELAY

Check rear window defogger relay.

Refer to [DEF-30, "Component Function Check"](#).

Is the inspection result normal?

YES >> GO TO 4.

NO >> Repair or replace the malfunctioning parts.

4. CHECK REAR WINDOW DEFOGGER

Check rear window defogger.

Refer to [DEF-31, "Component Function Check"](#).

Is the inspection result normal?

YES >> GO TO 5.

NO >> Repair or replace the malfunctioning parts.

5. CONFIRM THE OPERATION

Confirm the operation again.

Is the inspection result normal?

YES >> Check intermittent incident. Refer to [GI-34, "Intermittent Incident"](#).

NO >> GO TO 1.

A
B
C
D
E
F
G
H
I
J
K
DEF
M
N
O
P

REAR WINDOW DEFOGGER AND DOOR MIRROR DEFOGGER DO NOT OPERATE.

< SYMPTOM DIAGNOSIS >

REAR WINDOW DEFOGGER AND DOOR MIRROR DEFOGGER DO NOT OPERATE.

Diagnosis Procedure

INFOID:000000005049324

1.CHECK POWER SUPPLY AND GROUND CIRCUIT

Check power supply and ground circuit.

- BCM with Intelligent Key system: Refer to [DEF-21, "BCM \(BODY CONTROL SYSTEM\) \(WITH INTELLIGENT KEY SYSTEM\) : Diagnosis Procedure"](#).
- BCM without Intelligent Key system: Refer to [DEF-21, "BCM \(BODY CONTROL SYSTEM\) \(WITHOUT INTELLIGENT KEY SYSTEM\) : Diagnosis Procedure"](#).
- IPDM E/R with Intelligent Key system: Refer to [DEF-22, "IPDM E/R \(WITH INTELLIGENT KEY SYSTEM\) : Diagnosis Procedure"](#).
- IPDM E/R without Intelligent Key system: Refer to [DEF-23, "IPDM E/R \(WITHOUT INTELLIGENT KEY SYSTEM\) : Diagnosis Procedure"](#).

Is the inspection result normal?

YES >> GO TO 2.

NO >> Repair or replace the malfunctioning parts.

2.CHECK REAR WINDOW DEFOGGER SWITCH

Check rear window defogger switch.

- Without A/C: Refer to [DEF-28, "WITHOUT A/C : Component Function Check"](#).
- Without auto A/C: Refer to [DEF-26, "WITHOUT AUTO A/C : Component Function Check"](#).
- With auto A/C: Refer to [DEF-25, "WITH AUTO A/C : Component Function Check"](#).

Is the inspection result normal?

YES >> GO TO 3.

NO >> Repair or replace the malfunctioning parts.

3.CHECK REAR WINDOW DEFOGGER RELAY

Check rear window defogger relay.

Refer to [DEF-30, "Component Function Check"](#).

Is the inspection result normal?

YES >> GO TO 4.

NO >> Repair or replace the malfunctioning parts.

4.CHECK REAR WINDOW DEFOGGER

Check rear window defogger.

Refer to [DEF-31, "Component Function Check"](#).

Is the inspection result normal?

YES >> GO TO 5.

NO >> Repair or replace the malfunctioning parts.

5.CONFIRM THE OPERATION

Confirm the operation again.

Is the inspection result normal?

YES >> Check intermittent incident. Refer to [GI-34, "Intermittent Incident"](#).

NO >> GO TO 1.

REAR WINDOW DEFOGGER DOES NOT OPERATE BUT BOTH DOOR MIRROR DEFOGGER OPERATE.

< SYMPTOM DIAGNOSIS >

REAR WINDOW DEFOGGER DOES NOT OPERATE BUT BOTH DOOR MIRROR DEFOGGER OPERATE.

Diagnosis Procedure

INFOID:000000005049325

1. CHECK REAR WINDOW DEFOGGER

Check rear window defogger.

Refer to [DEF-31, "Component Function Check"](#).

Is the inspection result normal?

YES >> GO TO 2.

NO >> Repair or replace the malfunctioning parts.

2. CONFIRM THE OPERATION

Confirm the operation again

Is the inspection result normal?

YES >> Check intermittent incident. Refer to [GI-34, "Intermittent Incident"](#).

NO >> GO TO 1.

A
B
C
D
E
F
G
H
I
J
K
DEF
M
N
O
P

DOOR MIRROR DEFOGGER DOES NOT OPERATE

< SYMPTOM DIAGNOSIS >

DOOR MIRROR DEFOGGER DOES NOT OPERATE BOTH SIDES

BOTH SIDES : Description

INFOID:000000005072055

Driver side and passenger side door mirror defoggers do not operate.

BOTH SIDES : Diagnosis Procedure

INFOID:000000005049326

1.CHECK DOOR MIRROR DEFOGGER

Check door mirror defogger.

Refer to [DEF-34, "Component Function Check"](#).

Is the inspection result normal?

YES >> GO TO 2.

NO >> Repair or replace the malfunctioning parts.

2.CONFIRM THE OPERATION

Confirm the operation again.

Is the inspection result normal?

YES >> Check intermittent incident. Refer to [GI-34, "Intermittent Incident"](#).

NO >> GO TO 1.

DRIVER SIDE

DRIVER SIDE : Description

INFOID:000000005072056

Driver side door mirror defogger does not operate.

DRIVER SIDE : Diagnosis Procedure

INFOID:000000005049327

1.CHECK DRIVER SIDE DOOR MIRROR DEFOGGER

Check driver side door mirror defogger.

Refer to [DEF-35, "Component Function Check"](#).

Is the inspection result normal?

YES >> GO TO 2.

NO >> Repair or replace the malfunctioning parts.

2.CONFIRM THE OPERATION

Confirm the operation again.

Is the inspection result normal?

YES >> Check intermittent incident. Refer to [GI-34, "Intermittent Incident"](#).

NO >> GO TO 1.

PASSENGER SIDE

PASSENGER SIDE : Description

INFOID:000000005072057

Passenger side door mirror defogger does not operate.

PASSENGER SIDE : Diagnosis Procedure

INFOID:000000005049328

1.CHECK PASSENGER SIDE DOOR MIRROR DEFOGGER.

Check passenger side door mirror defogger.

Refer to [DEF-36, "Component Function Check"](#).

Is the inspection result normal?

YES >> GO TO 2.

NO >> Repair or replace the malfunctioning parts.

2.CONFIRM THE OPERATION

DOOR MIRROR DEFOGGER DOES NOT OPERATE

< SYMPTOM DIAGNOSIS >

Confirm the operation again.

Is the inspection result normal?

- YES >> Check intermittent incident. Refer to [GI-34. "Intermittent Incident"](#).
- NO >> GO TO 1.

A
B
C
D
E
F
G
H
I
J
K
DEF
M
N
O
P

ON IS NOT DISPLAYED WHEN PRESSING REAR WINDOW DEFOGGER SWITCH BUT IT IS OPERATED

< SYMPTOM DIAGNOSIS >

ON IS NOT DISPLAYED WHEN PRESSING REAR WINDOW DEFOGGER SWITCH BUT IT IS OPERATED

Diagnosis Procedure

INFOID:000000005049329

1. CHECK REAR WINDOW DEFOGGER ON SIGNAL

Check rear window defogger ON signal.

- Without A/C: Refer to [DEF-38, "WITHOUT A/C : Component Function Check"](#).
- Without auto A/C: Refer to [DEF-37, "WITHOUT AUTO A/C : Component Function Check"](#).
- With auto A/C: Refer to [DEF-37, "WITH AUTO A/C : Component Function Check"](#).

Is the inspection result normal?

YES >> GO TO 2.

NO >> Repair or replace the malfunctioning parts.

2. CONFIRM THE OPERATION

Confirm the operation again.

Is the inspection result normal?

YES >> Check intermittent incident. Refer to [GI-34, "Intermittent Incident"](#).

NO >> GO TO 1.

PRECAUTIONS

< PRECAUTION >

PRECAUTION

PRECAUTIONS

Precaution for Supplemental Restraint System (SRS) "AIR BAG" and "SEAT BELT PRE-TENSIONER"

INFOID:000000005133248

The Supplemental Restraint System such as "AIR BAG" and "SEAT BELT PRE-TENSIONER", used along with a front seat belt, helps to reduce the risk or severity of injury to the driver and front passenger for certain types of collision. This system includes seat belt switch inputs and dual stage front air bag modules. The SRS system uses the seat belt switches to determine the front air bag deployment, and may only deploy one front air bag, depending on the severity of a collision and whether the front occupants are belted or unbelted. Information necessary to service the system safely is included in the "SRS AIR BAG" and "SEAT BELT" of this Service Manual.

WARNING:

- To avoid rendering the SRS inoperative, which could increase the risk of personal injury or death in the event of a collision which would result in air bag inflation, all maintenance must be performed by an authorized NISSAN/INFINITI dealer.
- Improper maintenance, including incorrect removal and installation of the SRS, can lead to personal injury caused by unintentional activation of the system. For removal of Spiral Cable and Air Bag Module, see the "SRS AIR BAG".
- Do not use electrical test equipment on any circuit related to the SRS unless instructed to in this Service Manual. SRS wiring harnesses can be identified by yellow and/or orange harnesses or harness connectors.

PRECAUTIONS WHEN USING POWER TOOLS (AIR OR ELECTRIC) AND HAMMERS

WARNING:

- When working near the Air Bag Diagnosis Sensor Unit or other Air Bag System sensors with the ignition ON or engine running, DO NOT use air or electric power tools or strike near the sensor(s) with a hammer. Heavy vibration could activate the sensor(s) and deploy the air bag(s), possibly causing serious injury.
- When using air or electric power tools or hammers, always switch the ignition OFF, disconnect the battery, and wait at least 3 minutes before performing any service.

Precaution Necessary for Steering Wheel Rotation after Battery Disconnect

INFOID:000000005133247

NOTE:

- Before removing and installing any control units, first turn the push-button ignition switch to the LOCK position, then disconnect both battery cables.
- After finishing work, confirm that all control unit connectors are connected properly, then re-connect both battery cables.
- Always use CONSULT-III to perform self-diagnosis as a part of each function inspection after finishing work. If a DTC is detected, perform trouble diagnosis according to self-diagnosis results.

This vehicle is equipped with a push-button ignition switch and a steering lock unit.

If the battery is disconnected or discharged, the steering wheel will lock and cannot be turned.

If turning the steering wheel is required with the battery disconnected or discharged, follow the procedure below before starting the repair operation.

OPERATION PROCEDURE

1. Connect both battery cables.

NOTE:

Supply power using jumper cables if battery is discharged.

2. Turn the push-button ignition switch to ACC position.
(At this time, the steering lock will be released.)
3. Disconnect both battery cables. The steering lock will remain released with both battery cables disconnected and the steering wheel can be turned.
4. Perform the necessary repair operation.

A
B
C
D
E
F
G
H
I
J
K

DEF

M
N
O
P

PRECAUTIONS

< PRECAUTION >

5. When the repair work is completed, re-connect both battery cables. With the brake pedal released, turn the push-button ignition switch from ACC position to ON position, then to LOCK position. (The steering wheel will lock when the push-button ignition switch is turned to LOCK position.)
6. Perform self-diagnosis check of all control units using CONSULT-III.

FILAMENT

< REMOVAL AND INSTALLATION >

REMOVAL AND INSTALLATION

FILAMENT

Inspection and Repair

INFOID:000000005049288

INSPECTION

1. When measuring voltage, wrap tin foil around the top of the negative probe. Then press the foil against the wire with your finger.

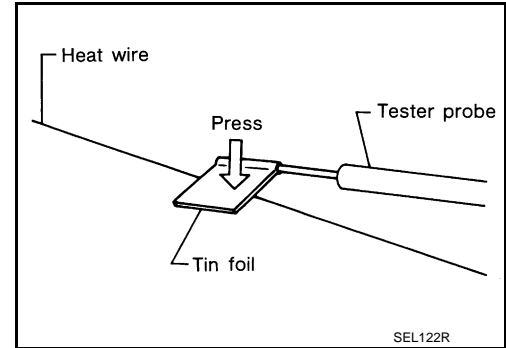

2. Attach probe circuit tester (in Volt range) to middle portion of each filament.

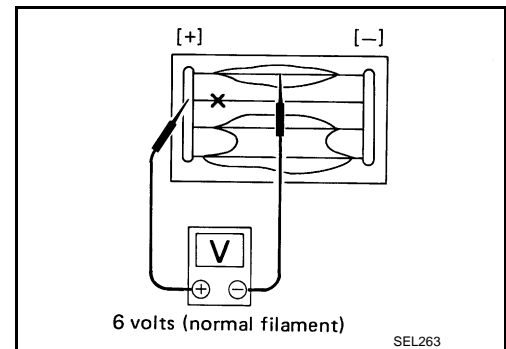

3. If a filament is burned out, circuit tester registers 0 or battery voltage.
4. To locate burned out point, move probe to left and right along filament. Test needle will swing abruptly when probe passes the point.

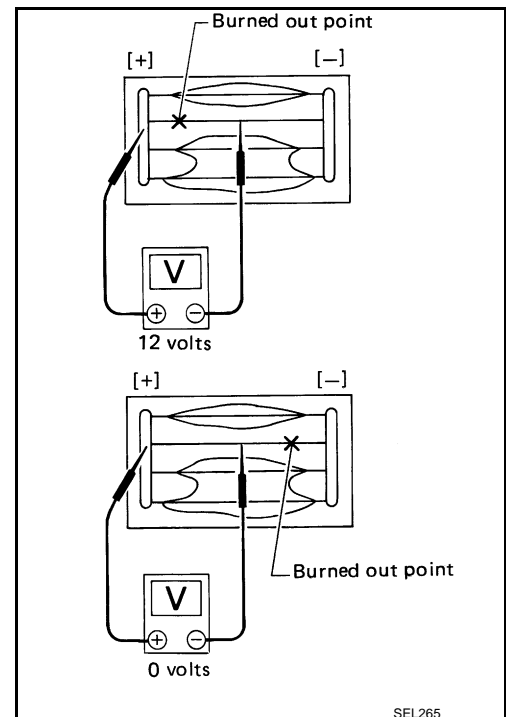

REPAIR

REPAIR EQUIPMENT

- Conductive silver composition (Dupont No. 4817 or equivalent)

A
B
C
D
E
F
G
H
I
J
K
DEF
M
N
O
P

FILAMENT

< REMOVAL AND INSTALLATION >

- Ruler 30 cm (11.8 in) long
- Drawing pen
- Heat gun
- Alcohol
- Cloth

REPAIRING PROCEDURE

1. Wipe broken heat wire and its surrounding area clean with a cloth dampened in alcohol.
2. Apply a small amount of conductive silver composition to tip of drawing pen. Shake silver composition container before use.
3. Place ruler on glass along broken line. Deposit conductive silver composition on break with drawing pen. Slightly overlap existing heat wire on both sides [preferably 5 mm (0.20 in)] of the break.

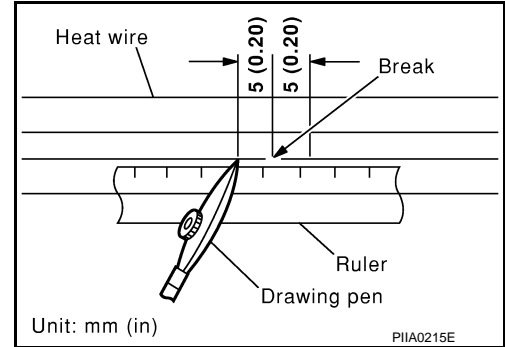

4. After repair has been completed, check repaired wire for continuity. This check should be conducted 10 minutes after silver composition is deposited. Do not touch repaired area while test is being conducted.

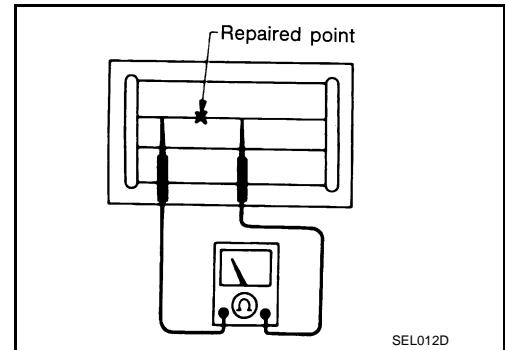

5. Apply a constant stream of hot air directly to the repaired area for approximately 20 minutes with a heat gun. A minimum distance of 3 cm (1.2 in) should be kept between repaired area and hot air outlet. If a heat gun is not available, let the repaired area dry for 24 hours.

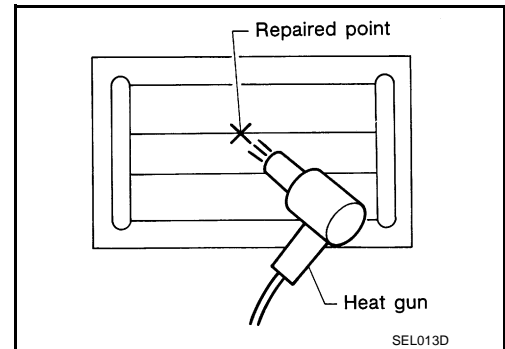

CONDENSER

< REMOVAL AND INSTALLATION >

CONDENSER

Exploded View

INFOID:000000005049344

Refer to [INT-26, "Exploded View"](#)

Removal and Installation

INFOID:000000005049345

REMOVAL

1. Remove the back door finisher lower.
Refer to [INT-26, "Removal and Installation"](#)
2. Remove bolt (A), and then remove condenser (1) from the vehicle body.

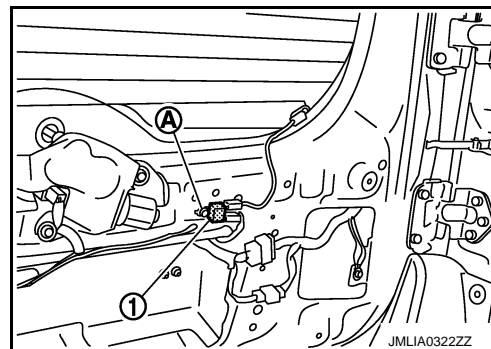

INSTALLATION

Install in the reverse order of removal.

A
B
C
D
E
F
G
H
I
J
K
DEF
M
N
O
P