

A
EC
C
D
E
F
G
H
I
J
K
L
M
N
O
P

SECTION EC

ENGINE CONTROL SYSTEM

CONTENTS

<p style="text-align: center;">MR18DE</p> <p>BASIC INSPECTION 8</p> <p>DIAGNOSIS AND REPAIR WORK FLOW 8</p> <p style="padding-left: 20px;">Work Flow8</p> <p style="padding-left: 20px;">Diagnostic Work Sheet 11</p> <p>INSPECTION AND ADJUSTMENT12</p> <p>BASIC INSPECTION12</p> <p style="padding-left: 20px;">BASIC INSPECTION : Special Repair Requirement 12</p> <p>ADDITIONAL SERVICE WHEN REPLACING CONTROL UNIT 15</p> <p style="padding-left: 20px;">ADDITIONAL SERVICE WHEN REPLACING CONTROL UNIT : Description 15</p> <p style="padding-left: 20px;">ADDITIONAL SERVICE WHEN REPLACING CONTROL UNIT : Special Repair Requirement 15</p> <p>IDLE SPEED 15</p> <p style="padding-left: 20px;">IDLE SPEED : Description 15</p> <p style="padding-left: 20px;">IDLE SPEED : Special Repair Requirement 16</p> <p>IGNITION TIMING 16</p> <p style="padding-left: 20px;">IGNITION TIMING : Description 16</p> <p style="padding-left: 20px;">IGNITION TIMING : Special Repair Requirement... 16</p> <p>VIN REGISTRATION 16</p> <p style="padding-left: 20px;">VIN REGISTRATION : Description 16</p> <p style="padding-left: 20px;">VIN REGISTRATION : Special Repair Requirement 16</p> <p>ACCELERATOR PEDAL RELEASED POSITION LEARNING 17</p> <p style="padding-left: 20px;">ACCELERATOR PEDAL RELEASED POSITION LEARNING : Description 17</p> <p style="padding-left: 20px;">ACCELERATOR PEDAL RELEASED POSITION LEARNING : Special Repair Requirement 17</p> <p>THROTTLE VALVE CLOSED POSITION LEARNING 17</p>	<p style="padding-left: 20px;">THROTTLE VALVE CLOSED POSITION LEARNING : Description17</p> <p style="padding-left: 20px;">THROTTLE VALVE CLOSED POSITION LEARNING : Special Repair Requirement17</p> <p>IDLE AIR VOLUME LEARNING17</p> <p style="padding-left: 20px;">IDLE AIR VOLUME LEARNING : Description17</p> <p style="padding-left: 20px;">IDLE AIR VOLUME LEARNING : Special Repair Requirement 17</p> <p>MIXTURE RATIO SELF-LEARNING VALUE CLEAR19</p> <p style="padding-left: 20px;">MIXTURE RATIO SELF-LEARNING VALUE CLEAR : Description19</p> <p style="padding-left: 20px;">MIXTURE RATIO SELF-LEARNING VALUE CLEAR : Special Repair Requirement19</p> <p>SYSTEM DESCRIPTION21</p> <p>ENGINE CONTROL SYSTEM21</p> <p style="padding-left: 20px;">System Diagram21</p> <p style="padding-left: 20px;">System Description22</p> <p style="padding-left: 20px;">Component Parts Location22</p> <p style="padding-left: 20px;">Component Description27</p> <p>MULTIPOINT FUEL INJECTION SYSTEM28</p> <p style="padding-left: 20px;">System Diagram28</p> <p style="padding-left: 20px;">System Description28</p> <p style="padding-left: 20px;">Component Parts Location31</p> <p style="padding-left: 20px;">Component Description36</p> <p>ELECTRIC IGNITION SYSTEM37</p> <p style="padding-left: 20px;">System Diagram37</p> <p style="padding-left: 20px;">System Description37</p> <p style="padding-left: 20px;">Component Parts Location38</p> <p style="padding-left: 20px;">Component Description43</p> <p>AIR CONDITIONING CUT CONTROL44</p> <p style="padding-left: 20px;">System Diagram44</p> <p style="padding-left: 20px;">System Description44</p> <p style="padding-left: 20px;">Component Parts Location45</p> <p style="padding-left: 20px;">Component Description50</p>
--	--

AUTOMATIC SPEED CONTROL DEVICE (ASCD)	51	Diagnosis Procedure	124
System Diagram	51	Component Inspection	125
System Description	51	P0031, P0032 A/F SENSOR 1 HEATER	127
Component Parts Location	53	Description	127
Component Description	58	DTC Logic	127
CAN COMMUNICATION	59	Diagnosis Procedure	127
System Description	59	Component Inspection	129
COOLING FAN CONTROL	60	P0037, P0038 HO2S2 HEATER	130
System Diagram	60	Description	130
System Description	60	DTC Logic	130
Component Parts Location	62	Diagnosis Procedure	131
Component Description	67	Component Inspection	132
EVAPORATIVE EMISSION SYSTEM	68	P0075 IVT CONTROL SOLENOID VALVE	133
System Diagram	68	Description	133
System Description	68	DTC Logic	133
Component Parts Location	72	Diagnosis Procedure	133
Component Description	77	Component Inspection	134
INTAKE VALVE TIMING CONTROL	78	P0101 MAF SENSOR	136
System Diagram	78	Description	136
System Description	78	DTC Logic	136
Component Parts Location	79	Component Function Check	137
Component Description	84	Diagnosis Procedure	138
ON BOARD DIAGNOSTIC (OBD) SYSTEM	85	Component Inspection	139
Diagnosis Description	85	P0102, P0103 MAF SENSOR	143
CONSULT-III Function	98	Description	143
Diagnosis Tool Function	106	DTC Logic	143
DTC/CIRCUIT DIAGNOSIS	109	Diagnosis Procedure	144
TROUBLE DIAGNOSIS - SPECIFICATION VALUE	109	Component Inspection	145
Description	109	P0112, P0113 IAT SENSOR	148
Component Function Check	109	Description	148
Diagnosis Procedure	110	DTC Logic	148
POWER SUPPLY AND GROUND CIRCUIT ..	117	Diagnosis Procedure	148
Diagnosis Procedure	117	Component Inspection	149
U0101 CAN COMM CIRCUIT	120	P0116 ECT SENSOR	150
Description	120	Description	150
DTC Logic	120	DTC Logic	150
Diagnosis Procedure	120	Diagnosis Procedure	151
U0140 CAN COMM CIRCUIT	121	Component Inspection	151
Description	121	P0117, P0118 ECT SENSOR	152
DTC Logic	121	Description	152
Diagnosis Procedure	121	DTC Logic	152
U1001 CAN COMM CIRCUIT	122	Diagnosis Procedure	152
Description	122	Component Inspection	153
DTC Logic	122	P0122, P0123 TP SENSOR	155
Diagnosis Procedure	122	Description	155
P0011 IVT CONTROL	123	DTC Logic	155
DTC Logic	123	Diagnosis Procedure	155
		Component Inspection	157
		Special Repair Requirement	157
		P0125 ECT SENSOR	158
		Description	158

DTC Logic	158	P0172 FUEL INJECTION SYSTEM FUNCTION	204	A
Diagnosis Procedure	159	DTC Logic	204	
Component Inspection	159	Diagnosis Procedure	205	EC
P0127 IAT SENSOR	161	P0181 FTT SENSOR	208	
Description	161	Description	208	C
DTC Logic	161	DTC Logic	208	
Diagnosis Procedure	162	Diagnosis Procedure	209	D
Component Inspection	162	Component Inspection	210	E
P0128 THERMOSTAT FUNCTION	163	P0182, P0183 FTT SENSOR	211	
DTC Logic	163	Description	211	D
Diagnosis Procedure	163	DTC Logic	211	
Component Inspection	164	Diagnosis Procedure	211	E
P0130 A/F SENSOR 1	165	Component Inspection	212	
Description	165	P0222, P0223 TP SENSOR	214	
DTC Logic	165	Description	214	F
Component Function Check	166	DTC Logic	214	
Diagnosis Procedure	167	Diagnosis Procedure	214	G
P0131 A/F SENSOR 1	169	Component Inspection	216	
Description	169	Special Repair Requirement	216	
DTC Logic	169	P0300, P0301, P0302, P0303, P0304 MIS-FIRE	217	H
Diagnosis Procedure	170	DTC Logic	217	
P0132 A/F SENSOR 1	172	Diagnosis Procedure	218	
Description	172	P0327, P0328 KS	223	I
DTC Logic	172	Description	223	
Diagnosis Procedure	173	DTC Logic	223	J
P0133 A/F SENSOR 1	175	Diagnosis Procedure	223	
Description	175	Component Inspection	224	
DTC Logic	175	P0335 CKP SENSOR (POS)	225	K
Diagnosis Procedure	177	Description	225	
P0137 HO2S2	180	DTC Logic	225	L
Description	180	Diagnosis Procedure	226	
DTC Logic	180	Component Inspection	228	
Component Function Check	181	P0340 CMP SENSOR (PHASE)	229	M
Diagnosis Procedure	182	Description	229	
Component Inspection	183	DTC Logic	229	
P0138 HO2S2	186	Diagnosis Procedure	230	N
Description	186	Component Inspection	231	
DTC Logic	186	P0420 THREE WAY CATALYST FUNCTION .	233	O
Component Function Check	187	DTC Logic	233	
Diagnosis Procedure	188	Component Function Check	234	
Component Inspection	191	Diagnosis Procedure	234	
P0139 HO2S2	194	P0441 EVAP CONTROL SYSTEM	238	P
Description	194	DTC Logic	238	
DTC Logic	194	Component Function Check	239	
Component Function Check	195	Diagnosis Procedure	240	
Diagnosis Procedure	196	Component Inspection (Drain filter)	243	
Component Inspection	197	P0442 EVAP CONTROL SYSTEM	244	
P0171 FUEL INJECTION SYSTEM FUNCTION	200	DTC Logic	244	
DTC Logic	200	Diagnosis Procedure	245	
Diagnosis Procedure	201			

Component Inspection (Fuel filler cap)	249	Component Function Check	289
Component Inspection (Drain filter)	249	Diagnosis Procedure	289
P0443 EVAP CANISTER PURGE VOLUME CONTROL SOLENOID VALVE	251	Component Inspection (Fuel filler cap)	292
Description	251	Component Inspection (Drain filter)	293
DTC Logic	251	P0460 FUEL LEVEL SENSOR	294
Diagnosis Procedure	252	Description	294
Component Inspection	254	DTC Logic	294
P0444, P0445 EVAP CANISTER PURGE VOLUME CONTROL SOLENOID VALVE	256	Diagnosis Procedure	294
Description	256	P0461 FUEL LEVEL SENSOR	295
DTC Logic	256	Description	295
Diagnosis Procedure	256	DTC Logic	295
Component Inspection	258	Component Function Check	295
P0447 EVAP CANISTER VENT CONTROL VALVE	259	Diagnosis Procedure	296
Description	259	P0462, P0463 FUEL LEVEL SENSOR	297
DTC Logic	259	Description	297
Diagnosis Procedure	259	DTC Logic	297
Component Inspection	261	Diagnosis Procedure	297
P0448 EVAP CANISTER VENT CONTROL VALVE	263	P0500 VSS	299
Description	263	Description	299
DTC Logic	263	DTC Logic	299
Diagnosis Procedure	264	Component Function Check	300
Component Inspection	265	Diagnosis Procedure	300
P0451 EVAP CONTROL SYSTEM PRES-SURE SENSOR	267	P0506 ISC SYSTEM	301
Description	267	Description	301
DTC Logic	267	DTC Logic	301
Diagnosis Procedure	267	Diagnosis Procedure	301
Component Inspection	269	P0507 ISC SYSTEM	303
P0452 EVAP CONTROL SYSTEM PRES-SURE SENSOR	270	Description	303
Description	270	DTC Logic	303
DTC Logic	270	Diagnosis Procedure	303
Diagnosis Procedure	271	P0605 ECM	305
Component Inspection	274	Description	305
P0453 EVAP CONTROL SYSTEM PRES-SURE SENSOR	275	DTC Logic	305
Description	275	Diagnosis Procedure	306
DTC Logic	275	P0607 ECM	307
Diagnosis Procedure	276	Description	307
Component Inspection	279	DTC Logic	307
P0455 EVAP CONTROL SYSTEM	281	Diagnosis Procedure	307
DTC Logic	281	P0643 SENSOR POWER SUPPLY	308
Diagnosis Procedure	282	DTC Logic	308
Component Inspection (Fuel filler cap)	285	Diagnosis Procedure	308
Component Inspection (Drain filter)	286	P0850 PNP SWITCH	310
P0456 EVAP CONTROL SYSTEM	287	Description	310
DTC Logic	287	DTC Logic	310
		Component Function Check	311
		Diagnosis Procedure	311
		P1148 CLOSED LOOP CONTROL	313
		DTC Logic	313
		P1212 TCS COMMUNICATION LINE	314
		Description	314

DTC Logic	314	Component Inspection (ASCD Brake Switch)	348	
Diagnosis Procedure	314	Component Inspection (ASCD Clutch Switch)	349	A
P1217 ENGINE OVER TEMPERATURE	315	Component Inspection (Stop Lamp Switch)	349	
DTC Logic	315	P1574 ASCD VEHICLE SPEED SENSOR	351	EC
Component Function Check	315	Description	351	
Diagnosis Procedure	316	DTC Logic	351	
P1225 TP SENSOR	319	Diagnosis Procedure	351	C
Description	319	P1715 INPUT SPEED SENSOR	353	
DTC Logic	319	Description	353	
Diagnosis Procedure	319	DTC Logic	353	D
Special Repair Requirement	320	Diagnosis Procedure	353	
P1226 TP SENSOR	321	P1805 BRAKE SWITCH	354	
Description	321	Description	354	E
DTC Logic	321	DTC Logic	354	
Diagnosis Procedure	321	Diagnosis Procedure	354	
Special Repair Requirement	322	Component Inspection (Stop Lamp Switch)	355	F
P1421 COLD START CONTROL	323	P2100, P2103 THROTTLE CONTROL MO-		
Description	323	TOR RELAY	357	
DTC Logic	323	Description	357	G
Diagnosis Procedure	323	DTC Logic	357	
P1550 BATTERY CURRENT SENSOR	325	Diagnosis Procedure	357	
Description	325	P2101 ELECTRIC THROTTLE CONTROL		
DTC Logic	325	FUNCTION	360	H
Diagnosis Procedure	326	Description	360	
Component Inspection	327	DTC Logic	360	I
P1551, P1552 BATTERY CURRENT SEN-		Diagnosis Procedure	360	
SOR	329	Component Inspection	363	J
Description	329	Special Repair Requirement	363	
DTC Logic	329	P2118 THROTTLE CONTROL MOTOR	364	
Diagnosis Procedure	330	Description	364	K
Component Inspection	331	DTC Logic	364	
P1553 BATTERY CURRENT SENSOR	333	Diagnosis Procedure	364	
Description	333	Component Inspection	365	L
DTC Logic	333	Special Repair Requirement	365	
Diagnosis Procedure	334	P2119 ELECTRIC THROTTLE CONTROL		
Component Inspection	335	ACTUATOR	366	M
P1554 BATTERY CURRENT SENSOR	337	Description	366	
Description	337	DTC Logic	366	
DTC Logic	337	Diagnosis Procedure	366	N
Component Function Check	337	Special Repair Requirement	367	
Diagnosis Procedure	338	P2122, P2123 APP SENSOR	368	
Component Inspection	340	Description	368	O
P1564 ASCD STEERING SWITCH	341	DTC Logic	368	
Description	341	Diagnosis Procedure	368	
DTC Logic	341	Component Inspection	370	P
Diagnosis Procedure	341	Special Repair Requirement	370	
Component Inspection	343	P2127, P2128 APP SENSOR	371	
P1572 ASCD BRAKE SWITCH	344	Description	371	
Description	344	DTC Logic	371	
DTC Logic	344	Diagnosis Procedure	371	
Diagnosis Procedure	345	Component Inspection	373	
		Special Repair Requirement	374	

P2135 TP SENSOR	375	MALFUNCTION INDICATOR LAMP	406
Description	375	Description	406
DTC Logic	375	Component Function Check	406
Diagnosis Procedure	375	Diagnosis Procedure	406
Component Inspection	377		
Special Repair Requirement	377	ON BOARD REFUELING VAPOR RECOV- ERY (ORVR)	407
P2138 APP SENSOR	378	Description	407
Description	378	Component Function Check	407
DTC Logic	378	Diagnosis Procedure	407
Diagnosis Procedure	379	Component Inspection (Refueling EVAP vapor cut valve)	410
Component Inspection	381	Component Inspection (Drain filter)	412
Special Repair Requirement	381		
P2A00 A/F SENSOR 1	382	POSITIVE CRANKCASE VENTILATION	413
Description	382	Description	413
DTC Logic	382	Component Inspection	413
Diagnosis Procedure	383		
ASCD BRAKE SWITCH	386	REFRIGERANT PRESSURE SENSOR	414
Description	386	Description	414
Component Function Check	386	Component Function Check	414
Diagnosis Procedure	386	Diagnosis Procedure	414
Component Inspection (ASCD Brake Switch)	388		
Component Inspection (ASCD Clutch Switch)	388	ECU DIAGNOSIS INFORMATION	416
ASCD INDICATOR	390	ECM	416
Description	390	Reference Value	416
Component Function Check	390	Wiring Diagram — ENGINE CONTROL SYSTEM	
Diagnosis Procedure	390	—	427
COOLING FAN	391	Fail Safe	445
Description	391	DTC Inspection Priority Chart	447
Component Function Check	391	DTC Index	448
Diagnosis Procedure	391	How to Set SRT Code	451
Component Inspection	392	Test Value and Test Limit	453
ELECTRICAL LOAD SIGNAL	393	SYMPTOM DIAGNOSIS	460
Description	393	ENGINE CONTROL SYSTEM SYMPTOMS ...	460
Component Function Check	393	Symptom Table	460
Diagnosis Procedure	393	NORMAL OPERATING CONDITION	464
FUEL INJECTOR	395	Description	464
Description	395	PRECAUTION	465
Component Function Check	395	PRECAUTIONS	465
Diagnosis Procedure	395	Precaution for Supplemental Restraint System (SRS) "AIR BAG" and "SEAT BELT PRE-TEN- SIONER"	465
Component Inspection	396	Precaution for Procedure without Cowl Top Cover.	465
FUEL PUMP	398	On Board Diagnosis (OBD) System of Engine and CVT	465
Description	398	General Precautions	466
Component Function Check	398	PREPARATION	469
Diagnosis Procedure	398	PREPARATION	469
Component Inspection	400	Special Service Tools	469
IGNITION SIGNAL	401	Commercial Service Tools	469
Description	401	PERIODIC MAINTENANCE	471
Component Function Check	401		
Diagnosis Procedure	401		
Component Inspection (Ignition Coil with Power Transistor)	404		
Component Inspection (Condenser)	405		

FUEL PRESSURE	471
Inspection	471
EVAP LEAK CHECK	473
Inspection	473
REMOVAL AND INSTALLATION	475
EVAP CANISTER	475
Exploded View	475
Removal and Installation	475
Inspection	476

SERVICE DATA AND SPECIFICATIONS (SDS)	477
SERVICE DATA AND SPECIFICATIONS (SDS)	477
Idle Speed	477
Ignition Timing	477
Calculated Load Value	477
Mass Air Flow Sensor	477

A
 EC
 C
 D
 E
 F
 G
 H
 I
 J
 K
 L
 M
 N
 O
 P

DIAGNOSIS AND REPAIR WORK FLOW

< BASIC INSPECTION >

[MR18DE]

BASIC INSPECTION

DIAGNOSIS AND REPAIR WORK FLOW

Work Flow

INFOID:000000004833140

OVERALL SEQUENCE

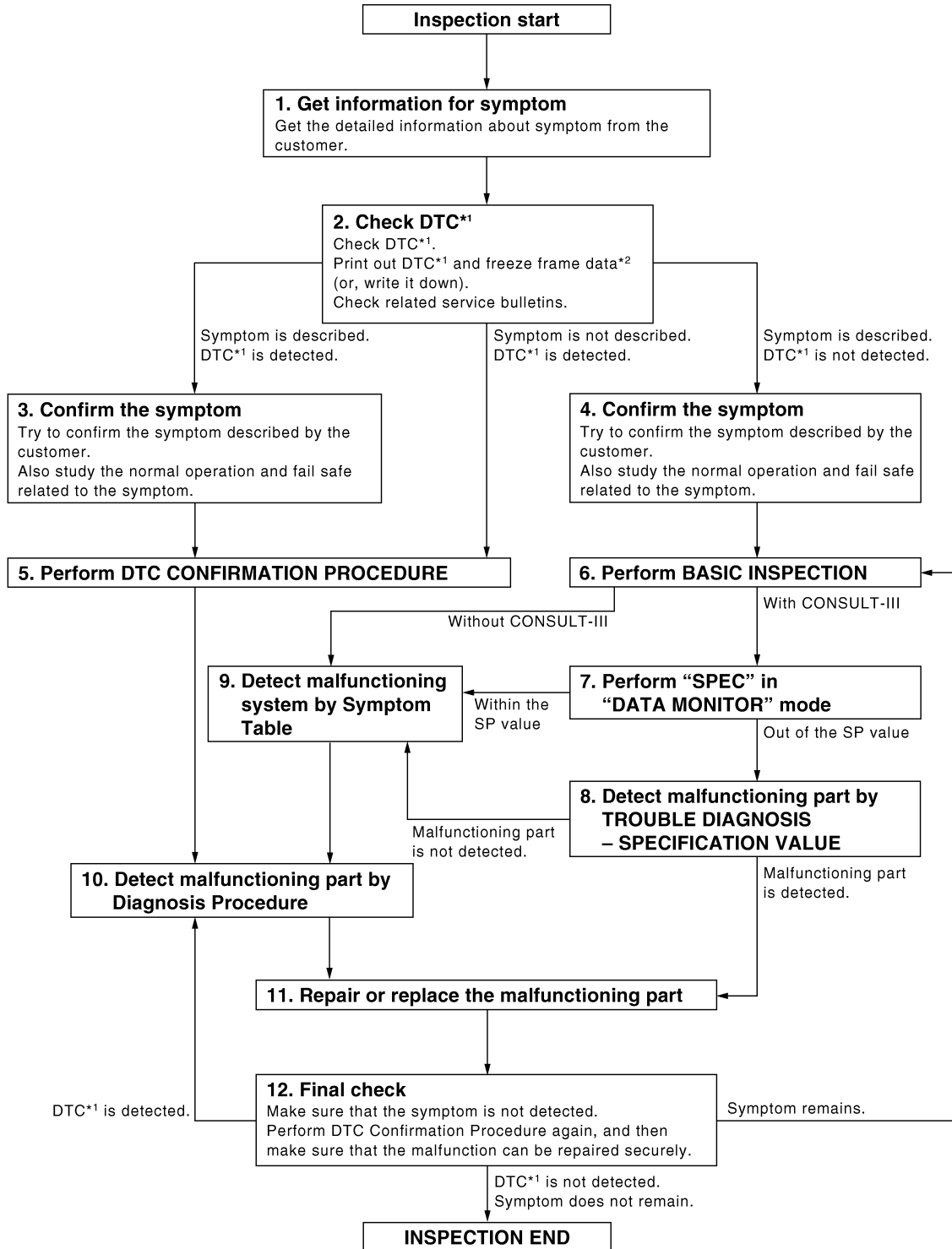

*1: Include 1st trip DTC.

*2: Include 1st trip freeze frame data.

JMBIA0078GB

DETAILED FLOW

DIAGNOSIS AND REPAIR WORK FLOW

[MR18DE]

< BASIC INSPECTION >

1.GET INFORMATION FOR SYMPTOM

Get the detailed information from the customer about the symptom (the condition and the environment when the incident/malfunction occurred) using the "Diagnostic Work Sheet". (Refer to [EC-11, "Diagnostic Work Sheet"](#).)

>> GO TO 2.

2.CHECK DTC

1. Check DTC.
2. Perform the following procedure if DTC is displayed.
 - Record DTC and freeze frame data. (Print them out with CONSULT-III or GST.)
 - Erase DTC. (Refer to "How to Erase DTC and 1st Trip DTC" in [EC-85, "Diagnosis Description"](#).)
 - Study the relationship between the cause detected by DTC and the symptom described by the customer. (Symptom Table is useful. Refer to [EC-460, "Symptom Table"](#).)
3. Check related service bulletins for information.

Is any symptom described and is any DTC detected?

Symptom is described, DTC is detected>>GO TO 3.

Symptom is described, DTC is not detected>>GO TO 4.

Symptom is not described, DTC is detected>>GO TO 5.

3.CONFIRM THE SYMPTOM

Try to confirm the symptom described by the customer (except MIL ON).

Also study the normal operation and fail safe related to the symptom. Refer to [EC-464, "Description"](#) and [EC-445, "Fail Safe"](#).

Diagnosis Work Sheet is useful to verify the incident.

Verify relation between the symptom and the condition when the symptom is detected.

>> GO TO 5.

4.CONFIRM THE SYMPTOM

Try to confirm the symptom described by the customer.

Also study the normal operation and fail safe related to the symptom. Refer to [EC-464, "Description"](#) and [EC-445, "Fail Safe"](#).

Diagnosis Work Sheet is useful to verify the incident.

Verify relation between the symptom and the condition when the symptom is detected.

>> GO TO 6.

5.PERFORM DTC CONFIRMATION PROCEDURE

Perform DTC CONFIRMATION PROCEDURE for the displayed DTC, and then make sure that DTC is detected again.

If two or more DTCs are detected, refer to [EC-447, "DTC Inspection Priority Chart"](#) and determine trouble diagnosis order.

NOTE:

- Freeze frame data is useful if the DTC is not detected.
- Perform Component Function Check if DTC CONFIRMATION PROCEDURE is not included on Service Manual. This simplified check procedure is an effective alternative though DTC cannot be detected during this check.
If the result of Component Function Check is NG, it is the same as the detection of DTC by DTC CONFIRMATION PROCEDURE.

Is DTC detected?

YES >> GO TO 10.

NO >> Check Intermittent Incident according to [EC-110, "Diagnosis Procedure"](#).

6.PERFORM BASIC INSPECTION

Perform [EC-12, "BASIC INSPECTION : Special Repair Requirement"](#).

Do you have CONSULT-III?

DIAGNOSIS AND REPAIR WORK FLOW

[MR18DE]

< BASIC INSPECTION >

- YES >> GO TO 7.
- NO >> GO TO 9.

7. PERFORM SPEC IN DATA MONITOR MODE

With CONSULT-III

Make sure that "MAS A/F SE-B1", "B/FUEL SCHDL" and "A/F ALPHA-B1" are within the SP value using "SPEC" of "DATA MONITOR" mode with CONSULT-III. Refer to [EC-109, "Component Function Check"](#).

Are they within the SP value?

- YES >> GO TO 9.
- NO >> GO TO 8.

8. DETECT MALFUNCTIONING PART BY TROUBLE DIAGNOSIS - SPECIFICATION VALUE

Detect malfunctioning part according to [EC-110, "Diagnosis Procedure"](#).

Is malfunctioning part detected?

- YES >> GO TO 11.
- NO >> GO TO 9.

9. DETECT MALFUNCTIONING SYSTEM BY SYMPTOM TABLE

Detect malfunctioning system according to [EC-460, "Symptom Table"](#) based on the confirmed symptom in step 4, and determine the trouble diagnosis order based on possible causes and symptom.

>> GO TO 10.

10. DETECT MALFUNCTIONING PART BY DIAGNOSIS PROCEDURE

Inspect according to Diagnosis Procedure of the system.

NOTE:

The Diagnosis Procedure in EC section described based on open circuit inspection. A short circuit inspection is also required for the circuit check in the Diagnosis Procedure. For details, refer to "Circuit Inspection" in [GI-37, "Circuit Inspection"](#).

Is malfunctioning part detected?

- YES >> GO TO 11.
- NO >> Monitor input data from related sensors or check the voltage of related ECM terminals using CONSULT-III. Refer to [EC-416, "Reference Value"](#).

11. REPAIR OR REPLACE THE MALFUNCTIONING PART

1. Repair or replace the malfunctioning part.
2. Reconnect parts or connectors disconnected during Diagnosis Procedure again after repair and replacement.
3. Check DTC. If DTC is displayed, erase it. Refer to "How to Erase DTC and 1st Trip DTC" in [EC-85, "Diagnosis Description"](#).

>> GO TO 12.

12. FINAL CHECK

When DTC was detected in step 2, perform DTC CONFIRMATION PROCEDURE or Component Function Check again, and then make sure that the malfunction have been repaired securely.

When symptom was described from the customer, refer to confirmed symptom in step 3 or 4, and make sure that the symptom is not detected.

Is DTC detected and does symptom remain?

- YES-1 >> DTC is detected: GO TO 10.
- YES-2 >> Symptom remains: GO TO 6.
- NO >> 1. Before returning the vehicle to the customer, make sure to erase unnecessary DTC in ECM (Refer to "How to Erase DTC and 1st Trip DTC" in [EC-85, "Diagnosis Description"](#).) and TCM (Refer to [TM-91, "Diagnosis Description"](#).)
 2. If the completion of SRT is needed, drive vehicle under the specific "DRIVING PATTERN" in [EC-451, "How to Set SRT Code"](#).
 3. INSPECTION END

INSPECTION AND ADJUSTMENT

BASIC INSPECTION

BASIC INSPECTION : Special Repair Requirement

INFOID:000000004833142

1.INSPECTION START

1. Check service records for any recent repairs that may indicate a related malfunction, or a current need for scheduled maintenance.
2. Open engine hood and check the following:
 - Harness connectors for improper connections
 - Wiring harness for improper connections, pinches and cut
 - Vacuum hoses for splits, kinks and improper connections
 - Hoses and ducts for leaks
 - Air cleaner clogging
 - Gasket
3. Confirm that electrical or mechanical loads are not applied.
 - Headlamp switch is OFF.
 - Air conditioner switch is OFF.
 - Rear window defogger switch is OFF.
 - Steering wheel is in the straight-ahead position, etc.
4. Start engine and warm it up until engine coolant temperature indicator points the middle of gauge. Ensure engine stays below 1,000 rpm.

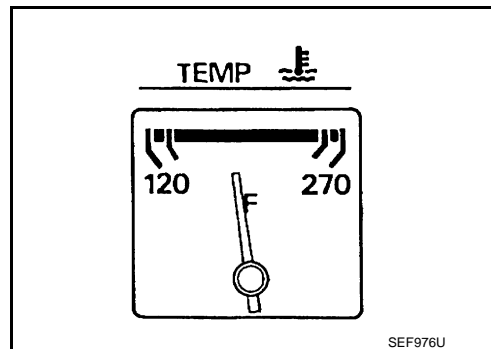
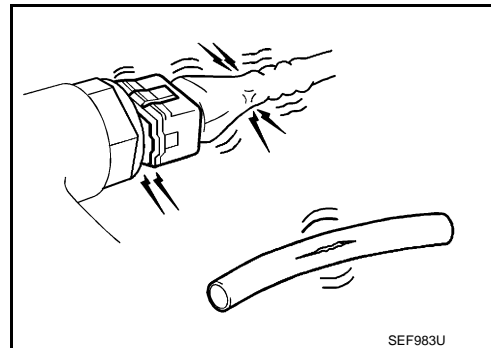

5. Run engine at about 2,000 rpm for about 2 minutes under no load.
6. Make sure that no DTC is displayed with CONSULT-III or GST.

Is any DTC detected?

- YES >> GO TO 2.
 NO >> GO TO 3.

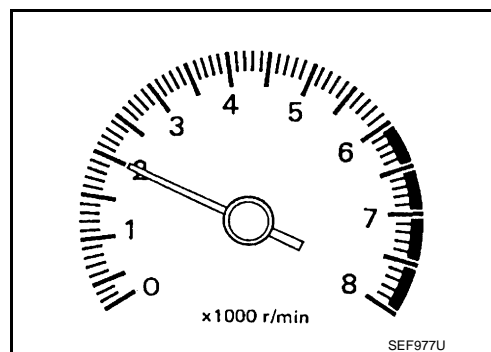

2.REPAIR OR REPLACE

Repair or replace components as necessary according to corresponding Diagnostic Procedure.

>> GO TO 3

3.CHECK IDLE SPEED

1. Run engine at about 2,000 rpm for about 2 minutes under no load.

INSPECTION AND ADJUSTMENT

[MR18DE]

< BASIC INSPECTION >

- Rev engine (2,000 to 3,000 rpm) two or three times under no load, then run engine at idle speed for about 1 minute.
- Check idle speed.
For procedure, refer to [EC-16, "IDLE SPEED : Special Repair Requirement"](#). For specification, refer to [EC-477, "Idle Speed"](#).

Is the inspection result normal?

- YES >> GO TO 10.
NO >> GO TO 4.

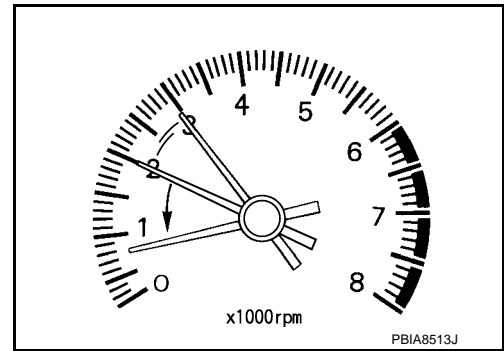

4.PERFORM ACCELERATOR PEDAL RELEASED POSITION LEARNING

- Stop engine.
- Perform [EC-17, "ACCELERATOR PEDAL RELEASED POSITION LEARNING : Special Repair Requirement"](#).

>> GO TO 5.

5.PERFORM THROTTLE VALVE CLOSED POSITION LEARNING

Perform [EC-17, "THROTTLE VALVE CLOSED POSITION LEARNING : Special Repair Requirement"](#).

>> GO TO 6.

6.PERFORM IDLE AIR VOLUME LEARNING

Perform [EC-17, "IDLE AIR VOLUME LEARNING : Special Repair Requirement"](#).

Is Idle Air Volume Learning carried out successfully?

- YES >> GO TO 7.
NO >> Follow the instruction of Idle Air Volume Learning. Then GO TO 4.

7.CHECK IDLE SPEED AGAIN

- Start engine and warm it up to normal operating temperature.
- Check idle speed.
For procedure, refer to [EC-16, "IDLE SPEED : Special Repair Requirement"](#).
For specification, refer to [EC-477, "Idle Speed"](#).

Is the inspection result normal?

- YES >> GO TO 10.
NO >> GO TO 8.

8.DETECT MALFUNCTIONING PART

Check the Following.

- Check camshaft position sensor (PHASE) and circuit. Refer to [EC-229, "DTC Logic"](#).
- Check crankshaft position sensor (POS) and circuit. Refer to [EC-225, "DTC Logic"](#).

Is the inspection result normal?

- YES >> GO TO 9.
NO >> Repair or replace. Then GO TO 4.

9.CHECK ECM FUNCTION

- Substitute another known-good ECM to check ECM function. (ECM may be the cause of an incident, but this is rare.)
- Perform initialization of NVIS (NATS) system and registration of all NVIS (NATS) ignition key IDs. Refer to [SEC-9, "ECM RECOMMUNICATING FUNCTION : Special Repair Requirement"](#) or [SEC-200, "ECM RECOMMUNICATING FUNCTION : Special Repair Requirement"](#).

>> GO TO 4.

10.CHECK IGNITION TIMING

- Run engine at idle.

INSPECTION AND ADJUSTMENT

[MR18DE]

< BASIC INSPECTION >

2. Check ignition timing with a timing light.
For procedure, refer to [EC-16, "IGNITION TIMING : Special Repair Requirement"](#). For specification, refer to [EC-477, "Ignition Timing"](#).

Is the inspection result normal?

- YES >> GO TO 19.
NO >> GO TO 11.

11.PERFORM ACCELERATOR PEDAL RELEASED POSITION LEARNING

1. Stop engine.
2. Perform [EC-17, "ACCELERATOR PEDAL RELEASED POSITION LEARNING : Special Repair Requirement"](#).

>> GO TO 12.

12.PERFORM THROTTLE VALVE CLOSED POSITION LEARNING

Perform [EC-17, "THROTTLE VALVE CLOSED POSITION LEARNING : Special Repair Requirement"](#).

>> GO TO 13.

13.PERFORM IDLE AIR VOLUME LEARNING

Perform [EC-17, "IDLE AIR VOLUME LEARNING : Special Repair Requirement"](#).

Is Idle Air Volume Learning carried out successfully?

- YES >> GO TO 14.
NO >> Follow the instruction of Idle Air Volume Learning. Then GO TO 4.

14.CHECK IDLE SPEED AGAIN

1. Start engine and warm it up to normal operating temperature.
2. Check idle speed.
For procedure, refer to [EC-16, "IDLE SPEED : Special Repair Requirement"](#).
For specification, refer to [EC-477, "Idle Speed"](#).

Is the inspection result normal?

- YES >> GO TO 15.
NO >> GO TO 17.

15.CHECK IGNITION TIMING AGAIN

1. Run engine at idle.
2. Check ignition timing with a timing light.
For procedure, refer to [EC-16, "IGNITION TIMING : Special Repair Requirement"](#). For specification, refer to [EC-477, "Ignition Timing"](#).

Is the inspection result normal?

- YES >> GO TO 19.
NO >> GO TO 16.

16.CHECK TIMING CHAIN INSTALLATION

Check timing chain installation. Refer to [EM-43, "Removal and Installation"](#).

Is the inspection result normal?

- YES >> GO TO 17.
NO >> Repair the timing chain installation. Then GO TO 4.

17.DETECT MALFUNCTIONING PART

Check the following.

- Check camshaft position sensor (PHASE) and circuit. Refer to [EC-229, "DTC Logic"](#).
- Check crankshaft position sensor (POS) and circuit. Refer to [EC-225, "DTC Logic"](#).

Is the inspection result normal?

- YES >> GO TO 18.
NO >> Repair or replace. Then GO TO 4.

INSPECTION AND ADJUSTMENT

< BASIC INSPECTION >

[MR18DE]

18. CHECK ECM FUNCTION

1. Substitute another known-good ECM to check ECM function. (ECM may be the cause of an incident, but this is rare.)
2. Perform initialization of NVIS (NATS) system and registration of all NVIS (NATS) ignition key IDs. Refer to [EC-15. "ADDITIONAL SERVICE WHEN REPLACING CONTROL UNIT : Special Repair Requirement"](#).

>> GO TO 4.

19. INSPECTION END

If ECM is replaced during this BASIC INSPECTION procedure, perform [EC-15. "ADDITIONAL SERVICE WHEN REPLACING CONTROL UNIT : Special Repair Requirement"](#).

>> INSPECTION END

ADDITIONAL SERVICE WHEN REPLACING CONTROL UNIT

ADDITIONAL SERVICE WHEN REPLACING CONTROL UNIT : Description

INFOID:000000004833143

When replacing ECM, this procedure must be performed.

ADDITIONAL SERVICE WHEN REPLACING CONTROL UNIT : Special Repair Requirement

INFOID:000000004833144

1. PERFORM INITIALIZATION OF NATS SYSTEM AND REGISTRATION OF ALL NATS IGNITION KEY IDS

Refer to [SEC-9. "ECM RECOMMUNICATING FUNCTION : Special Repair Requirement"](#) or [SEC-200. "ECM RECOMMUNICATING FUNCTION : Special Repair Requirement"](#).

>> GO TO 2.

2. PERFORM VIN REGISTRATION

Refer to [EC-16. "VIN REGISTRATION : Special Repair Requirement"](#).

>> GO TO 3.

3. PERFORM ACCELERATOR PEDAL RELEASED POSITION LEARNING

Refer to [EC-17. "ACCELERATOR PEDAL RELEASED POSITION LEARNING : Special Repair Requirement"](#).

>> GO TO 4.

4. PERFORM THROTTLE VALVE CLOSED POSITION LEARNING

Refer to [EC-17. "THROTTLE VALVE CLOSED POSITION LEARNING : Special Repair Requirement"](#).

>> GO TO 5.

5. PERFORM IDLE AIR VOLUME LEARNING

Refer to [EC-17. "IDLE AIR VOLUME LEARNING : Special Repair Requirement"](#).

>> END

IDLE SPEED

IDLE SPEED : Description

INFOID:000000004833145

This describes how to check the idle speed. For the actual procedure, follow the instructions in "BASIC INSPECTION".

INSPECTION AND ADJUSTMENT

< BASIC INSPECTION >

[MR18DE]

IDLE SPEED : Special Repair Requirement

INFOID:000000004833146

1.CHECK IDLE SPEED

With CONSULT-III

Check idle speed in "DATA MONITOR" mode with CONSULT-III.

With GST

Check idle speed with Service \$01 of GST.

>> INSPECTION END

IGNITION TIMING

IGNITION TIMING : Description

INFOID:000000004833147

This describes how to check the ignition timing. For the actual procedure, follow the instructions in "BASIC INSPECTION".

IGNITION TIMING : Special Repair Requirement

INFOID:000000004833148

1.CHECK IGNITION TIMING

1. Attach timing light to No. 1 ignition coil (1) wire as shown.

 : Vehicle front

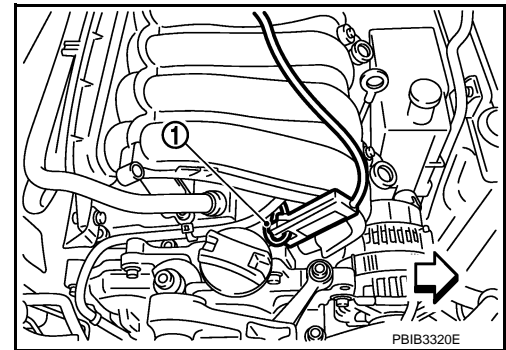

2. Check ignition timing.

1 : Timing indicator

>> INSPECTION END

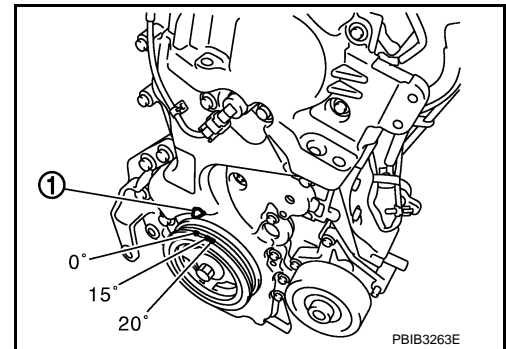

VIN REGISTRATION

VIN REGISTRATION : Description

INFOID:000000004833149

VIN Registration is an operation to registering VIN in ECM. It must be performed each time ECM is replaced.

NOTE:

Accurate VIN which is registered in ECM may be required for Inspection & Maintenance (I/M).

VIN REGISTRATION : Special Repair Requirement

INFOID:000000004833150

1.CHECK VIN

Check the VIN of the vehicle and note it. Refer to [GI-18, "Model Variation"](#).

>> GO TO 2.

2. PERFORM VIN REGISTRATION**With CONSULT-III**

1. Turn ignition switch ON and engine stopped.
2. Select "VIN REGISTRATION" in "WORK SUPPORT" mode.
3. Follow the instruction of CONSULT-III display.

>> END

ACCELERATOR PEDAL RELEASED POSITION LEARNING**ACCELERATOR PEDAL RELEASED POSITION LEARNING : Description** INFOID:000000004833151

Accelerator Pedal Released Position Learning is a function of ECM to learn the fully released position of the accelerator pedal by monitoring the accelerator pedal position sensor output signal. It must be performed each time harness connector of accelerator pedal position sensor or ECM is disconnected.

ACCELERATOR PEDAL RELEASED POSITION LEARNING : Special Repair RequirementINFOID:000000004833152**1. START**

1. Make sure that accelerator pedal is fully released.
2. Turn ignition switch ON and wait at least 2 seconds.
3. Turn ignition switch OFF and wait at least 10 seconds.
4. Turn ignition switch ON and wait at least 2 seconds.
5. Turn ignition switch OFF and wait at least 10 seconds.

>> END

THROTTLE VALVE CLOSED POSITION LEARNING**THROTTLE VALVE CLOSED POSITION LEARNING : Description** INFOID:000000004833153

Throttle Valve Closed Position Learning is a function of ECM to learn the fully closed position of the throttle valve by monitoring the throttle position sensor output signal. It must be performed each time harness connector of electric throttle control actuator or ECM is disconnected.

THROTTLE VALVE CLOSED POSITION LEARNING : Special Repair RequirementINFOID:000000004833154**1. START**

1. Make sure that accelerator pedal is fully released.
2. Turn ignition switch ON.
3. Turn ignition switch OFF and wait at least 10 seconds.
Make sure that throttle valve moves during above 10 seconds by confirming the operating sound.

>> END

IDLE AIR VOLUME LEARNING**IDLE AIR VOLUME LEARNING : Description** INFOID:000000004833155

Idle Air Volume Learning is a function of ECM to learn the idle air volume that keeps each engine idle speed within the specific range. It must be performed under any of the following conditions:

- Each time electric throttle control actuator or ECM is replaced.
- Idle speed or ignition timing is out of specification.

IDLE AIR VOLUME LEARNING : Special Repair RequirementINFOID:000000004833156**1. PRECONDITIONING**

Make sure that all of the following conditions are satisfied.

< BASIC INSPECTION >

Learning will be cancelled if any of the following conditions are missed for even a moment.

- Battery voltage: More than 12.9 V (At idle)
- Engine coolant temperature: 70 - 100°C (158 - 212°F)
- Selector lever: P or N (CVT), Neutral (M/T)
- Electric load switch: OFF

(Air conditioner, headlamp, rear window defogger)

On vehicles equipped with daytime light systems, if the parking brake is applied before the engine is started the headlamp will not be illuminated.

- Steering wheel: Neutral (Straight-ahead position)
- Vehicle speed: Stopped
- Transmission: Warmed-up
 - CVT models
- With CONSULT-III: Drive vehicle until "FLUID TEMP SE" in "DATA MONITOR" mode of "TRANSMISSION" system indicates less than 0.9 V.
- Without CONSULT-III: Drive vehicle for 10 minutes.
 - M/T models
- Drive vehicle for 10 minutes.

Do you have CONSULT-III?

- YES >> GO TO 2.
NO >> GO TO 3.

2.IDLE AIR VOLUME LEARNING**ⓅWith CONSULT-III**

1. Perform Accelerator Pedal Released Position Learning. Refer to [EC-17, "ACCELERATOR PEDAL RELEASED POSITION LEARNING : Special Repair Requirement"](#).
2. Perform Throttle Valve Closed Position Learning. Refer to [EC-17, "THROTTLE VALVE CLOSED POSITION LEARNING : Special Repair Requirement"](#).
3. Start engine and warm it up to normal operating temperature.
4. Select "IDLE AIR VOL LEARN" in "WORK SUPPORT" mode.
5. Touch "START" and wait 20 seconds.

Is "CMPLT" displayed on CONSULT-III screen?

- YES >> GO TO 4.
NO >> GO TO 5.

3.IDLE AIR VOLUME LEARNING**ⓧWithout CONSULT-III****NOTE:**

- It is better to count the time accurately with a clock.
 - It is impossible to switch the diagnostic mode when an accelerator pedal position sensor circuit has a malfunction.
1. Perform Accelerator Pedal Released Position Learning. Refer to [EC-17, "ACCELERATOR PEDAL RELEASED POSITION LEARNING : Special Repair Requirement"](#).
 2. Perform Throttle Valve Closed Position Learning. Refer to [EC-17, "THROTTLE VALVE CLOSED POSITION LEARNING : Special Repair Requirement"](#).
 3. Start engine and warm it up to normal operating temperature.
 4. Turn ignition switch OFF and wait at least 10 seconds.
 5. Confirm that accelerator pedal is fully released, turn ignition switch ON and wait 3 seconds.
 6. Repeat the following procedure quickly five times within 5 seconds.
 - Fully depress the accelerator pedal.
 - Fully release the accelerator pedal.
 7. Wait 7 seconds, fully depress the accelerator pedal and keep it for approx. 20 seconds until the MIL stops blinking and turned ON.
 8. Fully release the accelerator pedal within 3 seconds after the MIL turned ON.
 9. Start engine and let it idle.

10. Wait 20 seconds.

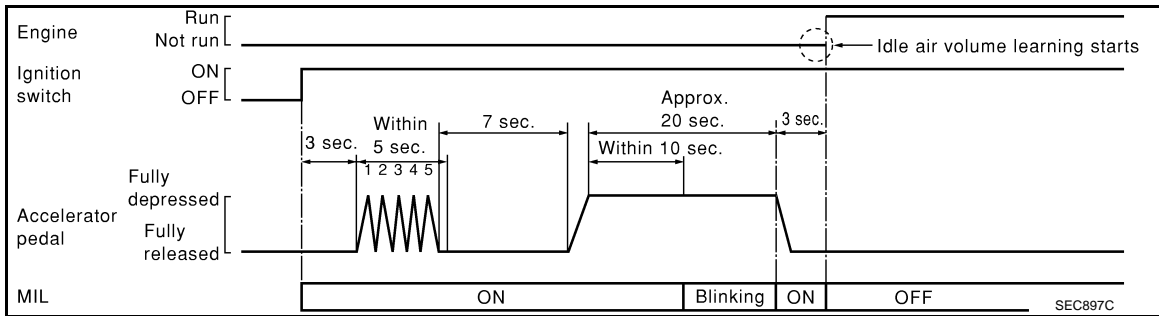

>> GO TO 4.

4. CHECK IDLE SPEED AND IGNITION TIMING

Rev up the engine two or three times and make sure that idle speed and ignition timing are within the specifications.

ITEM	SPECIFICATION
Idle speed	CVT: 700 ± 50 rpm (in P or N position) M/T: 700 ± 50 rpm (in Neutral position)
Ignition timing	CVT: 13 ± 5°BTDC (in P or N position) M/T: 13 ± 5°BTDC (in Neutral position)

Is the inspection result normal?

YES >> INSPECTION END

5. DETECT MALFUNCTIONING PART

Check the following

- Check that throttle valve is fully closed.
- Check PCV valve operation.
- Check that downstream of throttle valve is free from air leakage.

Is the inspection result normal?

YES >> GO TO 6.

NO >> Repair or replace malfunctioning part.

6. DETECT MALFUNCTIONING PART

Engine component parts and their installation condition are questionable. Check and eliminate the cause of the incident.

It is useful to perform "TROUBLE DIAGNOSIS - SPECIFICATION VALUE". Refer to [EC-109. "Description"](#).

If any of the following conditions occur after the engine has started, eliminate the cause of the incident and perform Idle Air Volume Learning again:

- Engine stalls.
- Erroneous idle.

>> INSPECTION END

MIXTURE RATIO SELF-LEARNING VALUE CLEAR

MIXTURE RATIO SELF-LEARNING VALUE CLEAR : Description

INFOID:000000004833157

This describes how to erase the mixture ratio self-learning value. For the actual procedure, follow the instructions in "Diagnosis Procedure".

MIXTURE RATIO SELF-LEARNING VALUE CLEAR : Special Repair Requirement

INFOID:000000004833158

1. START

With CONSULT-III

INSPECTION AND ADJUSTMENT

[MR18DE]

< BASIC INSPECTION >

1. Start engine and warm it up to normal operating temperature.
2. Select "SELF-LEARNING CONT" in "WORK SUPPORT" mode with CONSULT-III.
3. Clear mixture ratio self-learning value by touching "CLEAR".

With GST

1. Start engine and warm it up to normal operating temperature.
2. Turn ignition switch OFF.
3. Disconnect mass air flow sensor harness connector.
4. Restart engine and let it idle for at least 5 seconds.
5. Stop engine and reconnect mass air flow sensor harness connector.
6. Select Service \$03 with GST. Make sure DTC P0102 is detected.
7. Select Service \$04 with GST to erase the DTC P0102.

>> END

< SYSTEM DESCRIPTION >

SYSTEM DESCRIPTION

ENGINE CONTROL SYSTEM

System Diagram

INFOID:000000004833159

A

EC

C

D

E

F

G

H

I

J

K

L

M

N

O

P

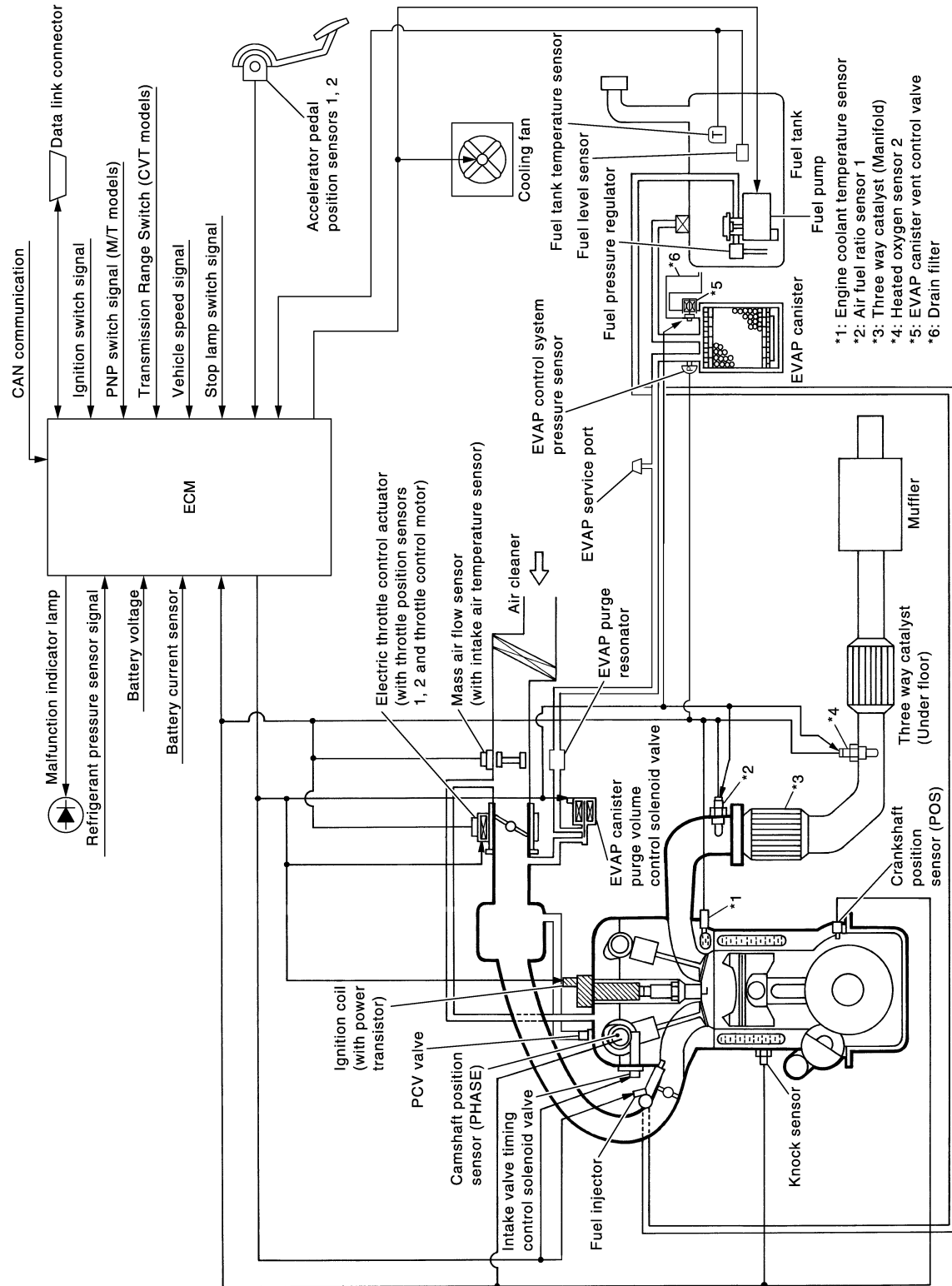

JMBIA2930GB

ENGINE CONTROL SYSTEM

< SYSTEM DESCRIPTION >

[MR18DE]

System Description

INFOID:000000004833160

ECM performs various controls such as fuel injection control and ignition timing control.

Component Parts Location

INFOID:000000004833161

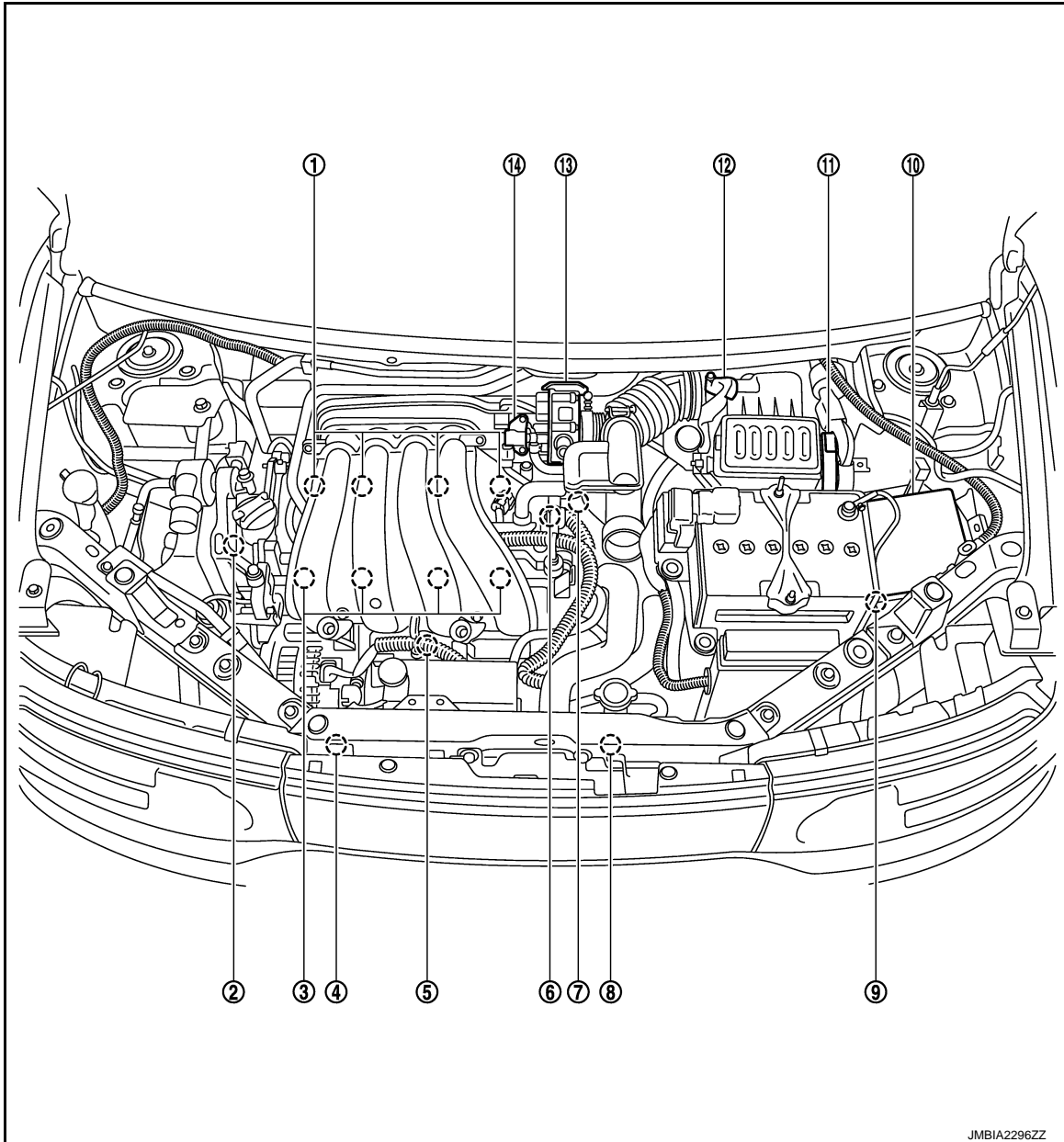

- | | | |
|--|---|---|
| 1. Ignition coil (with power transistor) and spark plug | 2. Intake valve timing control solenoid valve | 3. Fuel injector |
| 4. Refrigerant pressure sensor | 5. Knock sensor | 6. Camshaft position sensor (PHASE) |
| 7. Engine coolant temperature sensor | 8. Cooling fan motor | 9. Battery current sensor |
| 10. IPDM E/R | 11. ECM | 12. Mass air flow sensor (with intake air temperature sensor) |
| 13. Electric throttle control actuator (with built in throttle position sensor and throttle control motor) | 14. EVAP canister purge volume control solenoid valve | |

ENGINE CONTROL SYSTEM

< SYSTEM DESCRIPTION >

[MR18DE]

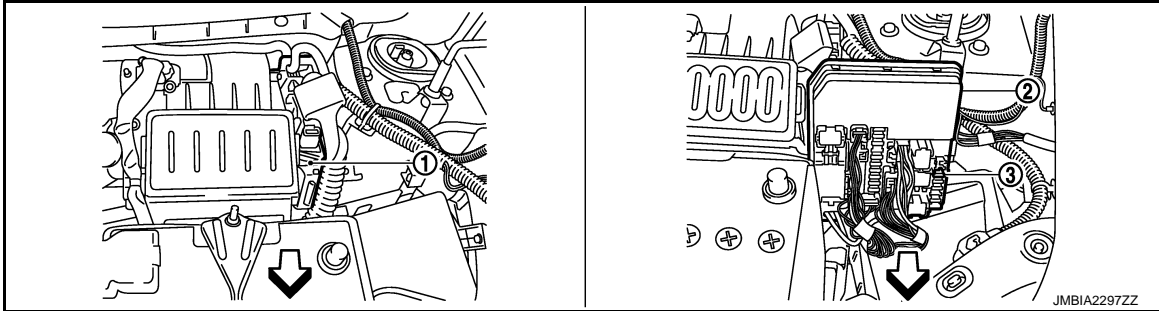

- 1. ECM
- 2. IPDM E/R
- 3. Fuel pump fuse (15 A)

← Vehicle front

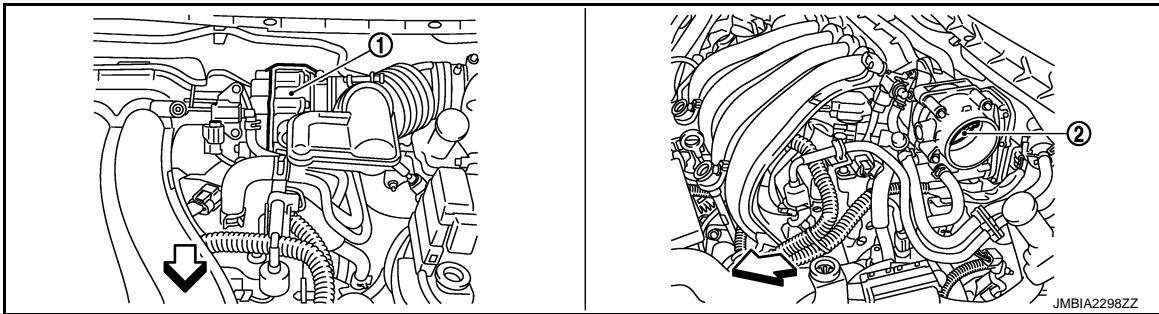

- 1. Electric throttle control actuator (with built-in position sensor, throttle control motor)
- 2. Throttle valve

← Vehicle front

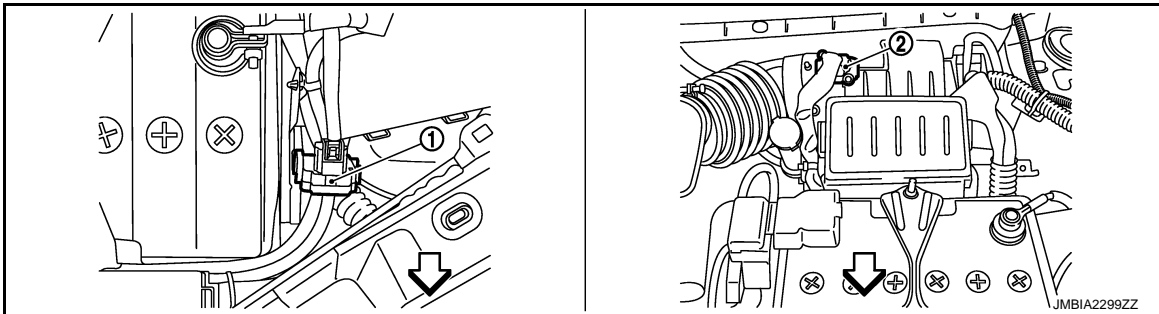

- 1. Battery current sensor
- 2. Mass air flow sensor (with Intake air temperature sensor)

← Vehicle front

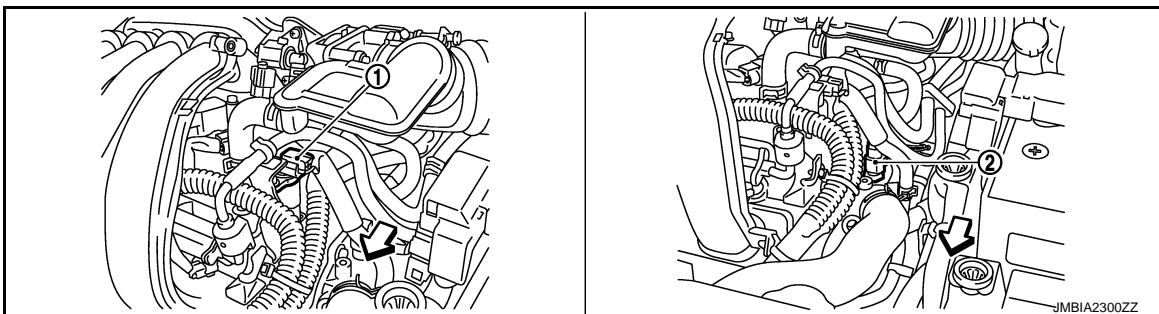

A
EC
C
D
E
F
G
H
I
J
K
L
M
N
O
P

ENGINE CONTROL SYSTEM

[MR18DE]

< SYSTEM DESCRIPTION >

1. Camshaft position sensor (PHASE)
2. Engine coolant temperature sensor

↶ Vehicle front

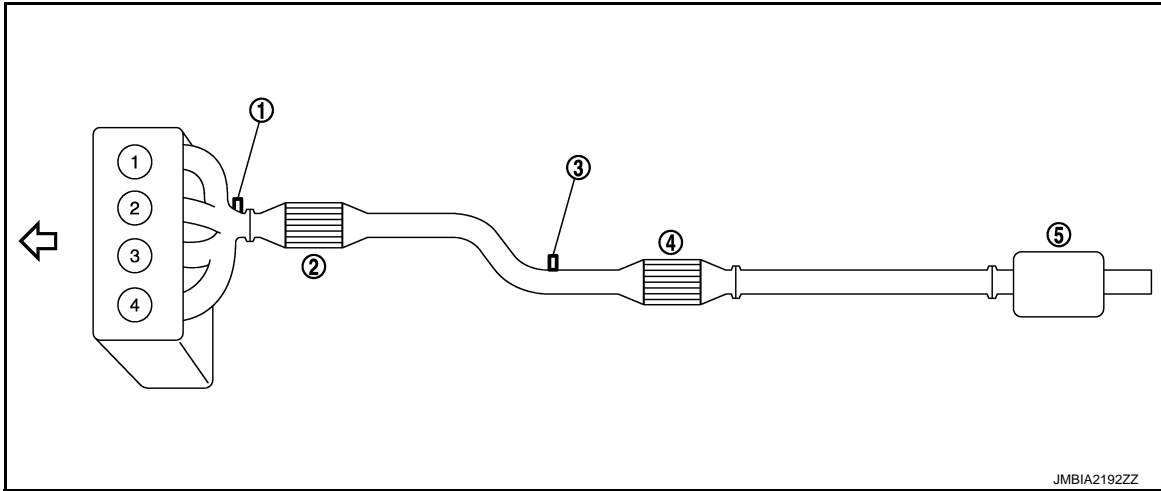

JMBIA2192ZZ

1. Air fuel ratio (A/F) sensor 1
2. Three way catalyst (Manifold)
3. Heated oxygen sensor 2
4. Three way catalyst (under floor)
5. Muffler

↶ Vehicle front

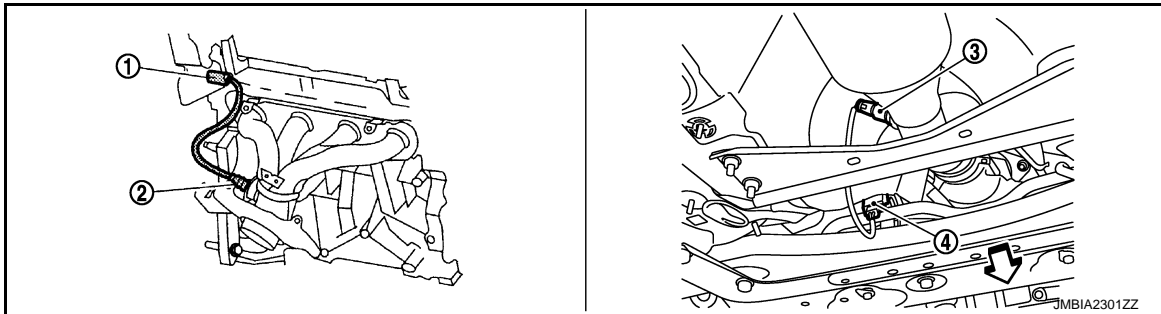

JMBIA2301ZZ

1. Air fuel ratio (A/F) sensor 1 harness
2. Air fuel ratio (A/F) sensor 1 connector
3. Heated oxygen sensor 2
4. Heated oxygen sensor 2 harness connector

↶ Vehicle front

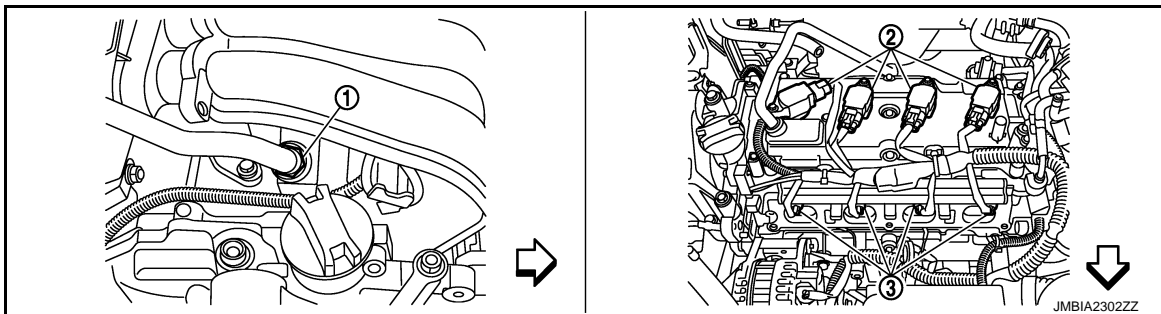

JMBIA2302ZZ

1. PCV valve
2. Ignition coil (with power transistor)
3. Fuel injector

↶ Vehicle front

ENGINE CONTROL SYSTEM

< SYSTEM DESCRIPTION >

[MR18DE]

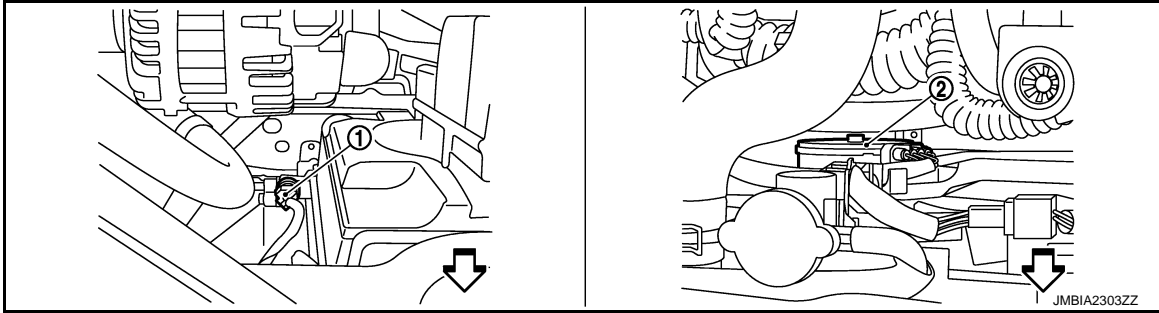

- 1. Refrigerant pressure sensor
- 2. Cooling fan motor

← Vehicle front

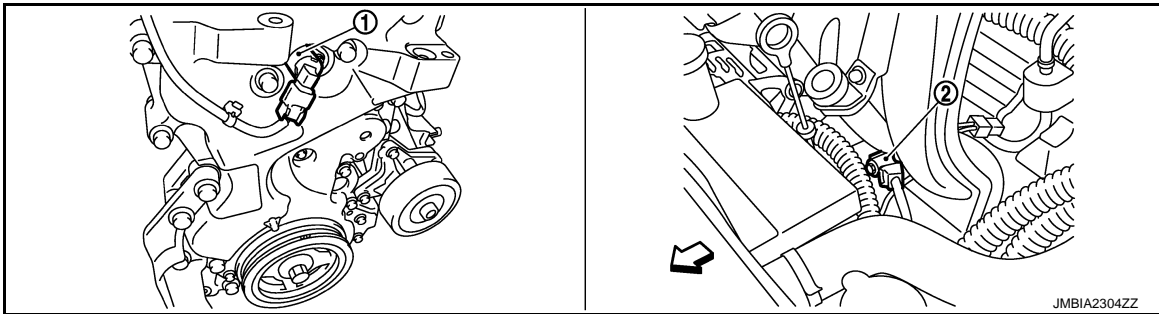

- 1. Intake valve timing control solenoid
- 2. Knock sensor valve

← Vehicle front

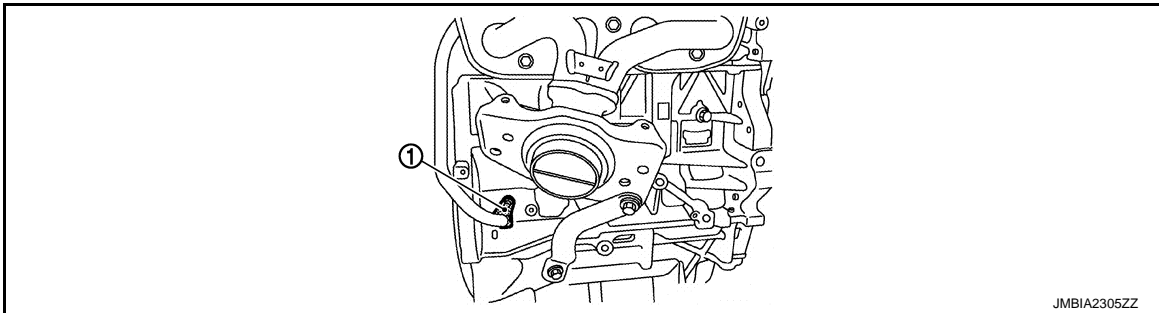

- 1. Crankshaft position sensor (POS)

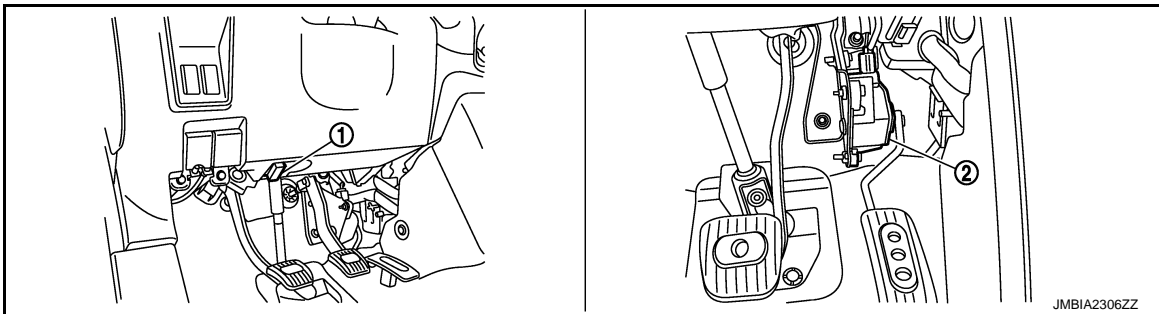

- 1. Data link connector
- 2. Accelerator pedal position sensor

A
EC
C
D
E
F
G
H
I
J
K
L
M
N
O
P

ENGINE CONTROL SYSTEM

< SYSTEM DESCRIPTION >

[MR18DE]

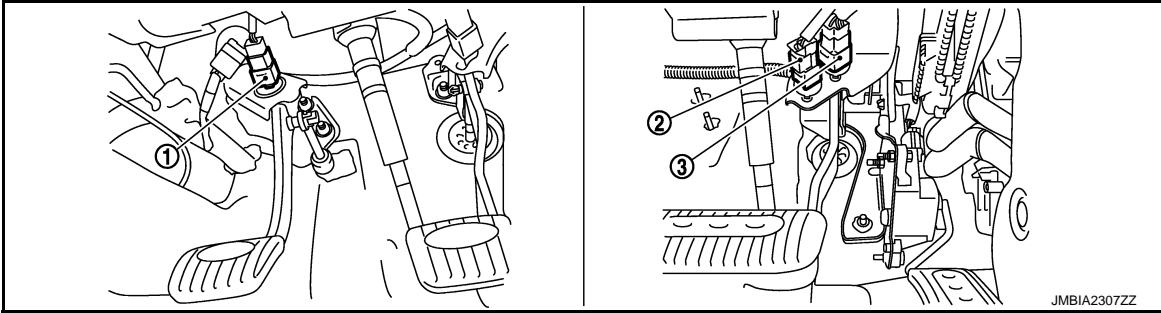

- 1. ASCD clutch switch
- 2. ASCD brake switch
- 3. Stop lamp switch

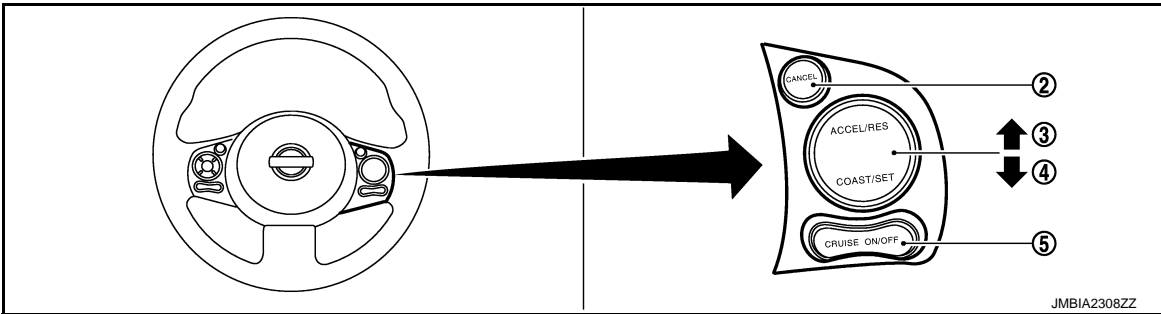

- 1. ASCD steering switch
- 2. CANCEL switch
- 3. RESUME/ACCELERATE switch
- 4. SET/COST switch
- 5. MAIN switch

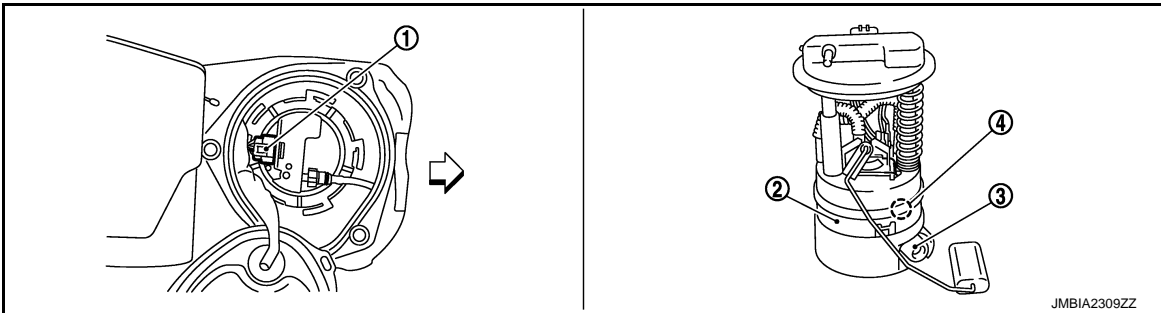

- 1. Fuel level sensor unit and fuel pump harness connector
 - 2. Fuel level sensor unit and fuel pump
 - 3. Fuel pressure regulator
 - 4. Fuel tank temperature sensor
- ↙ Vehicle front

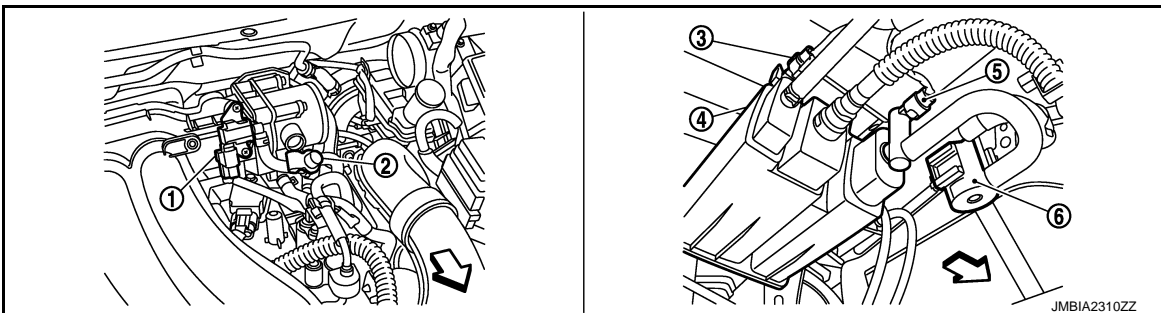

- 1. EVAP canister purge volume control solenoid valve
- 2. EVAP service port
- 3. EVAP control system pressure sensor

ENGINE CONTROL SYSTEM

[MR18DE]

< SYSTEM DESCRIPTION >

4. EVAP canister
 ↶ Vehicle front
5. EVAP canister vent control valve
6. Drain filter

A

Component Description

INFOID:000000004833162

EC

Component	Reference
A/F sensor 1	EC-165, "Description"
A/F sensor 1 heater	EC-127, "Description"
Accelerator pedal position sensor	EC-368, "Description"
ASCD brake switch	EC-344, "Description"
ASCD steering switch	EC-341, "Description"
ASCD vehicle speed sensor	EC-351, "Description"
Battery current sensor	EC-325, "Description"
Camshaft position sensor (PHASE)	EC-229, "Description"
Crankshaft position sensor (POS)	EC-225, "Description"
Cooling fan motor	EC-60, "System Description"
Electric throttle control actuator	EC-366, "Description"
Engine coolant temperature sensor	EC-152, "Description"
EVAP canister purge volume control solenoid valve	EC-251, "Description"
EVAP canister vent control valve	EC-259, "Description"
EVAP control system pressure sensor	EC-267, "Description"
Fuel injector	EC-395, "Description"
Fuel level sensor	EC-294, "Description"
Fuel pump	EC-398, "Description"
Fuel tank temperature sensor	EC-208, "Description"
Heated oxygen sensor 2	EC-180, "Description"
Heated oxygen sensor 2 heater	EC-130, "Description"
Ignition signal	EC-401, "Description"
Intake air temperature sensor	EC-148, "Description"
Intake valve timing control solenoid valve	EC-78, "System Description"
Knock sensor	EC-223, "Description"
Mass air flow sensor	EC-136, "Description"
Park/neutral position switch	EC-310, "Description"
PCV valve	EC-413, "Description"
Refrigerant pressure sensor	EC-414, "Description"
Stop lamp switch	EC-354, "Description"
Throttle control motor	EC-364, "Description"
Throttle control motor relay	EC-357, "Description"
Throttle position sensor	EC-155, "Description"

C

D

E

F

G

H

I

J

K

L

M

N

O

P

MULTIPOINT FUEL INJECTION SYSTEM

[MR18DE]

< SYSTEM DESCRIPTION >

MULTIPOINT FUEL INJECTION SYSTEM

System Diagram

INFOID:000000004833163

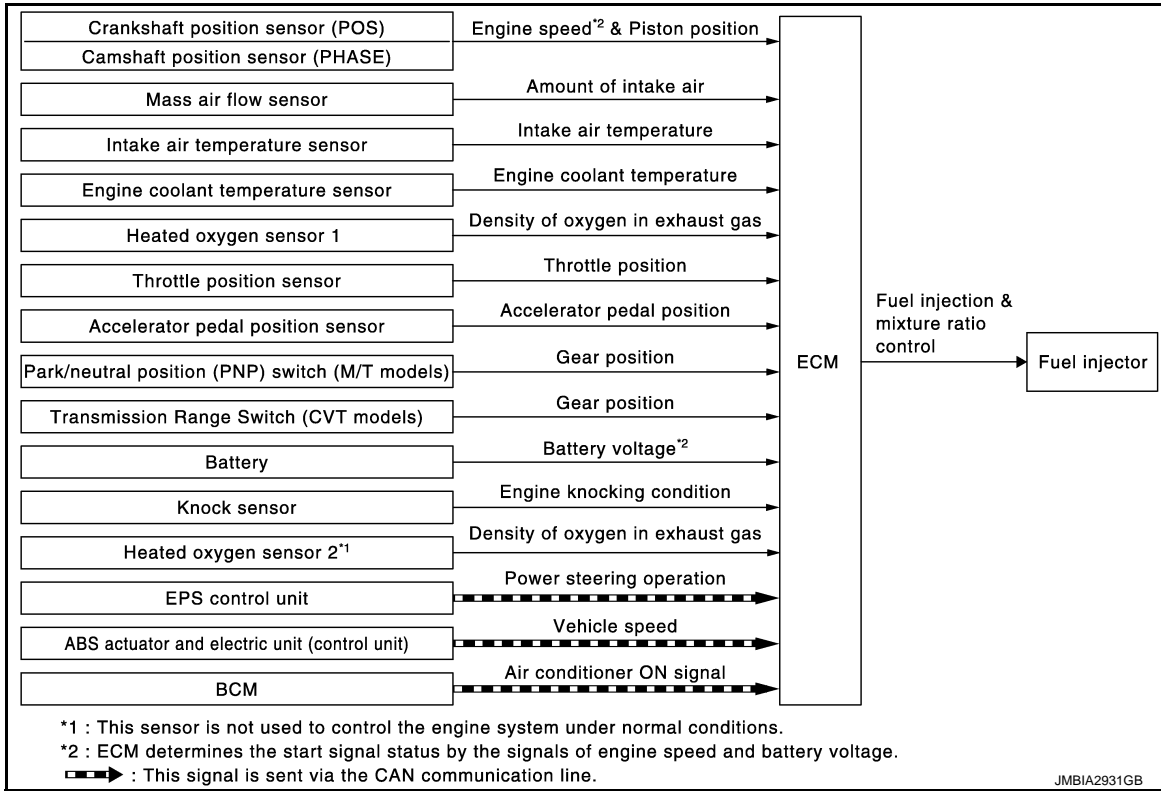

System Description

INFOID:000000004833164

INPUT/OUTPUT SIGNAL CHART

Sensor	Input signal to ECM	ECM function	Actuator
Crankshaft position sensor (POS)	Engine speed*3 Piston position	Fuel injection & mixture ratio control	Fuel injector
Camshaft position sensor (PHASE)			
Mass air flow sensor	Amount of intake air		
Intake air temperature sensor	Intake air temperature		
Engine coolant temperature sensor	Engine coolant temperature		
Air fuel ratio (A/F) sensor 1	Density of oxygen in exhaust gas		
Throttle position sensor	Throttle position		
Accelerator pedal position sensor	Accelerator pedal position		
Park/neutral position (PNP) switch (M/T models)	Gear position		
Transmission range switch (CVT models)	Gear position		
Battery	Battery voltage*3		
Knock sensor	Engine knocking condition		
Heated oxygen sensor 2*1	Density of oxygen in exhaust gas		
EPS control unit	Power steering operation*2		
ABS actuator and electric unit (control unit)	Vehicle speed*2		
BCM	Air conditioner ON signal*2		

*1: This sensor is not used to control the engine system under normal conditions.

*2: This signal is sent to the ECM via the CAN communication line.

MULTIPOINT FUEL INJECTION SYSTEM

[MR18DE]

< SYSTEM DESCRIPTION >

*3: ECM determines the start signal status by the signals of engine speed and battery voltage.

SYSTEM DESCRIPTION

The amount of fuel injected from the fuel injector is determined by the ECM. The ECM controls the length of time the valve remains open (injection pulse duration). The amount of fuel injected is a program value in the ECM memory. The program value is preset by engine operating conditions. These conditions are determined by input signals (for engine speed and intake air) from the crankshaft position sensor (POS), camshaft position sensor (PHASE) and the mass air flow sensor.

VARIOUS FUEL INJECTION INCREASE/DECREASE COMPENSATION

In addition, the amount of fuel injected is compensated to improve engine performance under various operating conditions as listed below.

<Fuel increase>

- During warm-up
- When starting the engine
- During acceleration
- Hot-engine operation
- When selector lever is changed from N to D (CVT models)
- High-load, high-speed operation

<Fuel decrease>

- During deceleration
- During high engine speed operation

MIXTURE RATIO FEEDBACK CONTROL (CLOSED LOOP CONTROL)

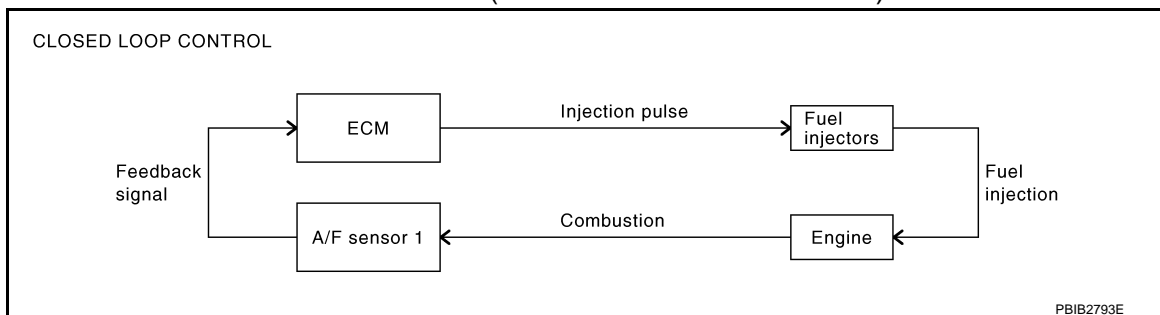

The mixture ratio feedback system provides the best air-fuel mixture ratio for driveability and emission control. The three way catalyst (manifold) can better reduce CO, HC and NOx emissions. This system uses A/F sensor 1 in the exhaust manifold to monitor whether the engine operation is rich or lean. The ECM adjusts the injection pulse width according to the sensor voltage signal. For more information about A/F sensor 1, refer to [EC-165, "Description"](#). This maintains the mixture ratio within the range of stoichiometric (ideal air-fuel mixture).

This stage is referred to as the closed loop control condition.

Heated oxygen sensor 2 is located downstream of the three way catalyst (manifold). Even if the switching characteristics of A/F sensor 1 shift, the air-fuel ratio is controlled to stoichiometric by the signal from heated oxygen sensor 2.

• Open Loop Control

The open loop system condition refers to when the ECM detects any of the following conditions. Feedback control stops in order to maintain stabilized fuel combustion.

- Deceleration and acceleration
- High-load, high-speed operation
- Malfunction of A/F sensor 1 or its circuit
- Insufficient activation of A/F sensor 1 at low engine coolant temperature
- High engine coolant temperature
- During warm-up
- After shifting from N to D (CVT models)
- When starting the engine

MIXTURE RATIO SELF-LEARNING CONTROL

The mixture ratio feedback control system monitors the mixture ratio signal transmitted from A/F sensor 1. This feedback signal is then sent to the ECM. The ECM controls the basic mixture ratio as close to the theoretical mixture ratio as possible. However, the basic mixture ratio is not necessarily controlled as originally

MULTIPOINT FUEL INJECTION SYSTEM

[MR18DE]

< SYSTEM DESCRIPTION >

designed. Both manufacturing differences (i.e., mass air flow sensor hot wire) and characteristic changes during operation (i.e., fuel injector clogging) directly affect mixture ratio. Accordingly, the difference between the basic and theoretical mixture ratios is monitored in this system. This is then computed in terms of "injection pulse duration" to automatically compensate for the difference between the two ratios.

"Fuel trim" refers to the feedback compensation value compared against the basic injection duration. Fuel trim includes short-term fuel trim and long-term fuel trim.

"Short-term fuel trim" is the short-term fuel compensation used to maintain the mixture ratio at its theoretical value. The signal from A/F sensor 1 indicates whether the mixture ratio is RICH or LEAN compared to the theoretical value. The signal then triggers a reduction in fuel volume if the mixture ratio is rich, and an increase in fuel volume if it is lean.

"Long-term fuel trim" is overall fuel compensation carried out over time to compensate for continual deviation of the short-term fuel trim from the central value. Continual deviation will occur due to individual engine differences, wear over time and changes in the usage environment.

FUEL INJECTION TIMING

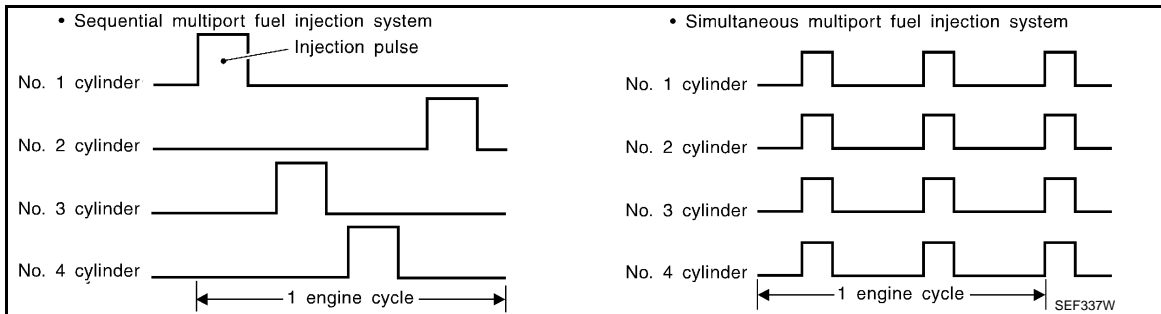

Two types of systems are used.

- **Sequential Multiport Fuel Injection System**
Fuel is injected into each cylinder during each engine cycle according to the ignition order. This system is used when the engine is running.
- **Simultaneous Multiport Fuel Injection System**
Fuel is injected simultaneously into all four cylinders twice each engine cycle. In other words, pulse signals of the same width are simultaneously transmitted from the ECM.
The four injectors will then receive the signals two times for each engine cycle.
This system is used when the engine is being started and/or if the fail-safe system (CPU) is operating.

FUEL SHUT-OFF

Fuel to each cylinder is cut off during deceleration, operation of the engine at excessively high speeds or operation of the vehicle at excessively high speeds.

MULTIPOINT FUEL INJECTION SYSTEM

< SYSTEM DESCRIPTION >

[MR18DE]

Component Parts Location

INFOID:000000004833165

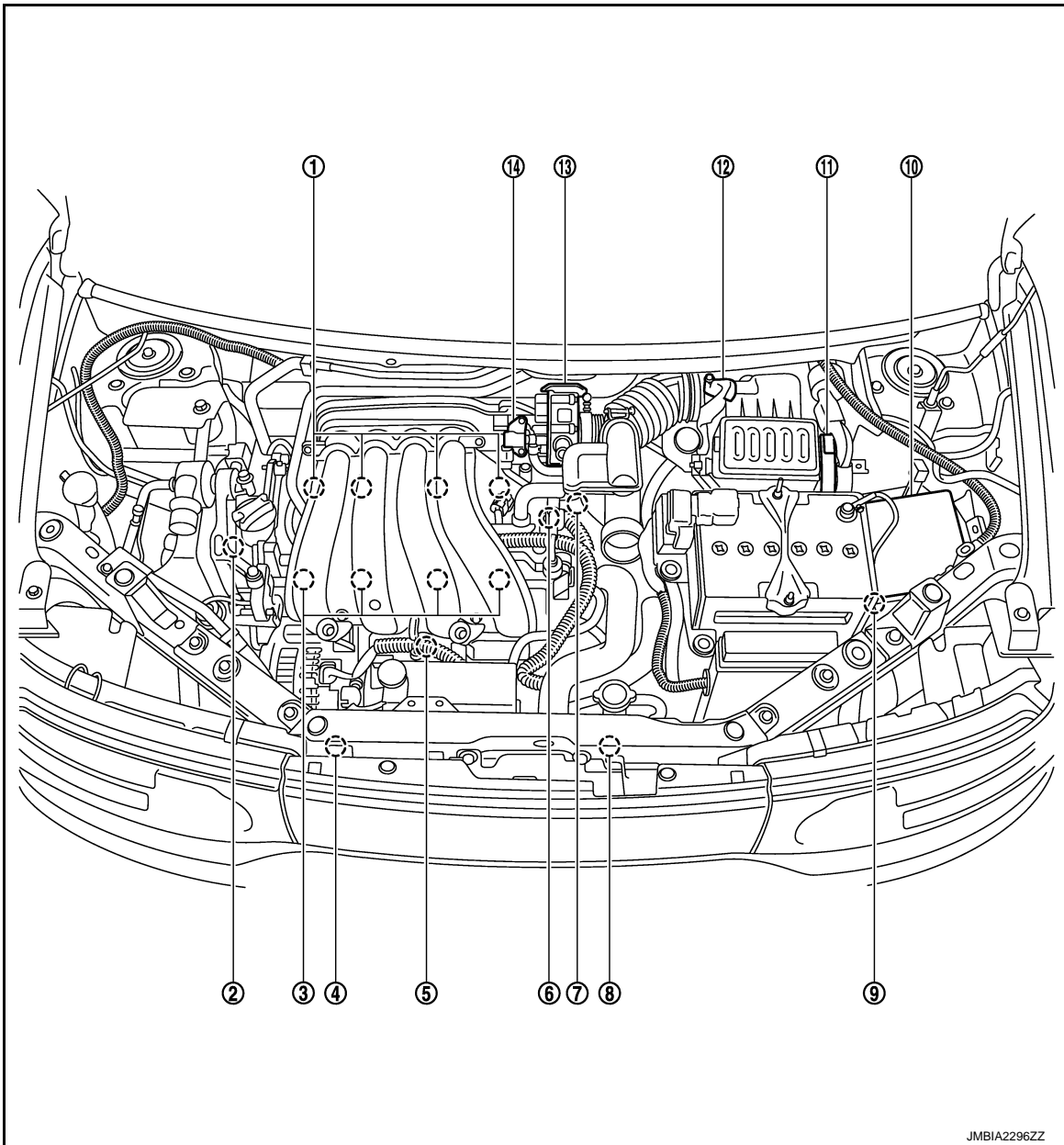

JMBIA2296ZZ

- | | | |
|--|---|---|
| 1. Ignition coil (with power transistor) and spark plug | 2. Intake valve timing control solenoid valve | 3. Fuel injector |
| 4. Refrigerant pressure sensor | 5. Knock sensor | 6. Camshaft position sensor (PHASE) |
| 7. Engine coolant temperature sensor | 8. Cooling fan motor | 9. Battery current sensor |
| 10. IPDM E/R | 11. ECM | 12. Mass air flow sensor (with intake air temperature sensor) |
| 13. Electric throttle control actuator (with built in throttle position sensor and throttle control motor) | 14. EVAP canister purge volume control solenoid valve | |

A

EC

C

D

E

F

G

H

I

J

K

L

M

N

O

P

MULTIPOINT FUEL INJECTION SYSTEM

< SYSTEM DESCRIPTION >

[MR18DE]

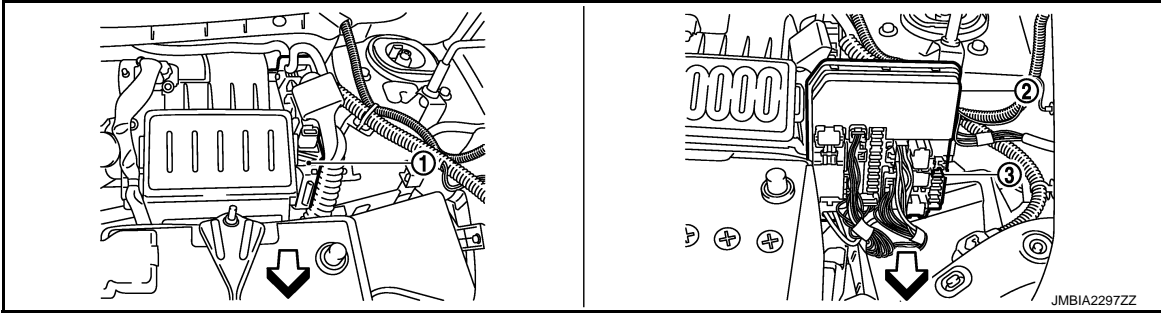

- 1. ECM
- 2. IPDM E/R
- 3. Fuel pump fuse (15 A)

← Vehicle front

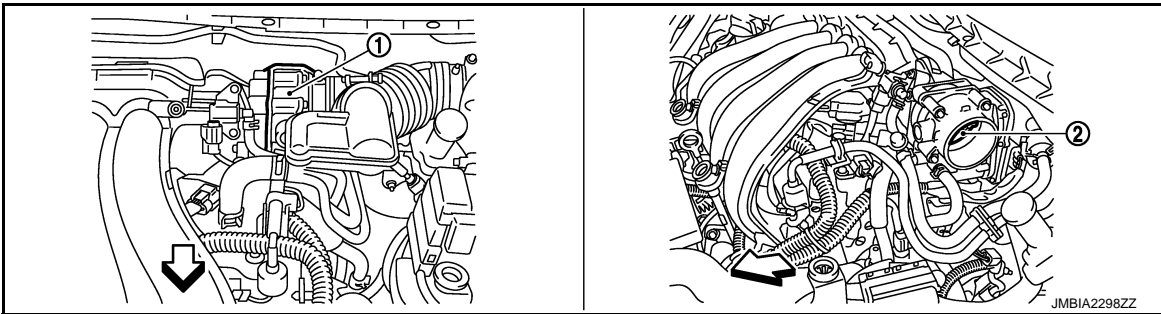

- 1. Electric throttle control actuator (with built-in position sensor, throttle control motor)
- 2. Throttle valve

← Vehicle front

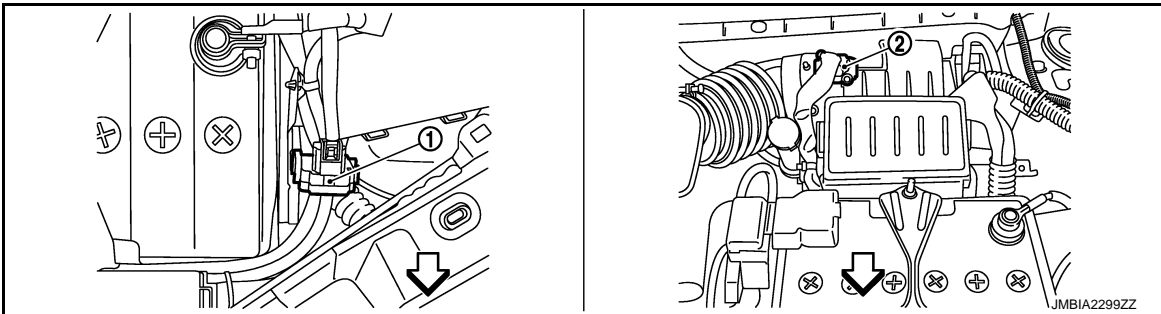

- 1. Battery current sensor
- 2. Mass air flow sensor (with Intake air temperature sensor)

← Vehicle front

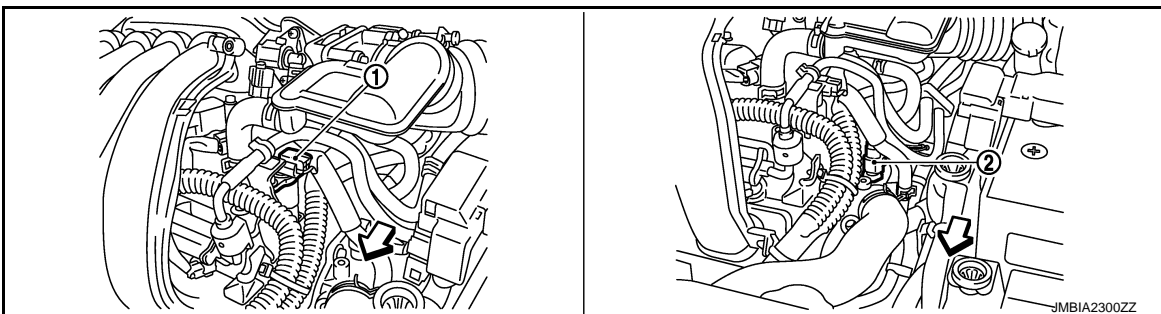

MULTIPOINT FUEL INJECTION SYSTEM

[MR18DE]

< SYSTEM DESCRIPTION >

1. Camshaft position sensor (PHASE)
2. Engine coolant temperature sensor

← Vehicle front

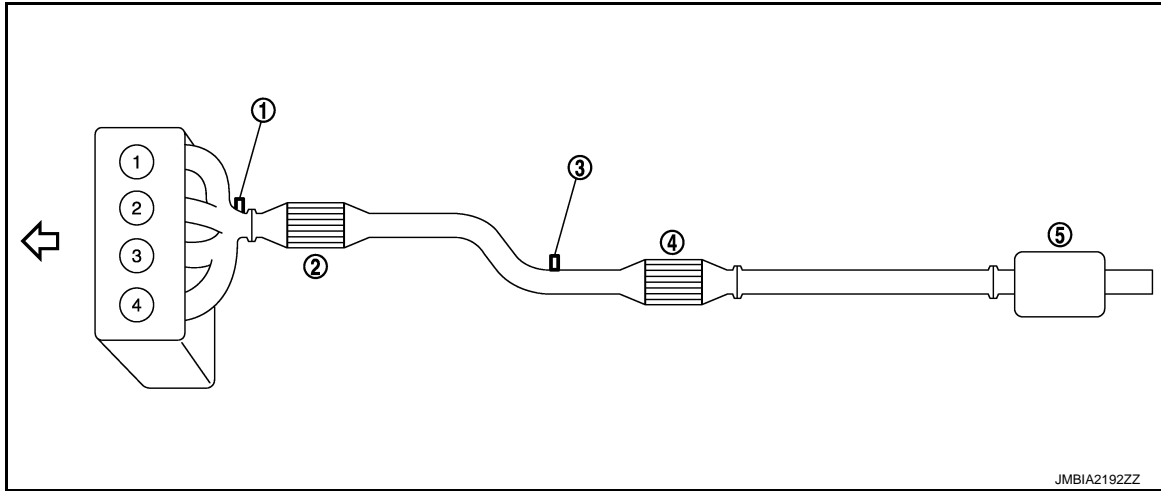

1. Air fuel ratio (A/F) sensor 1
2. Three way catalyst (Manifold)
3. Heated oxygen sensor 2
4. Three way catalyst (under floor)
5. Muffler

← Vehicle front

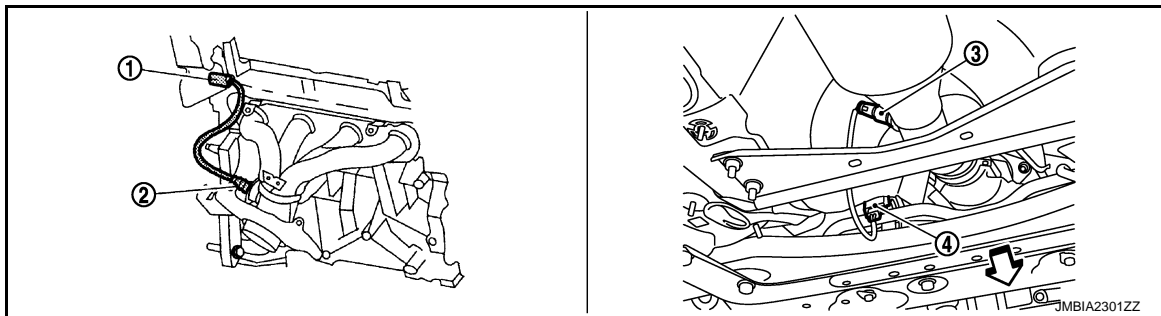

1. Air fuel ratio (A/F) sensor 1 harness
2. Air fuel ratio (A/F) sensor 1 connector
3. Heated oxygen sensor 2
4. Heated oxygen sensor 2 harness connector

← Vehicle front

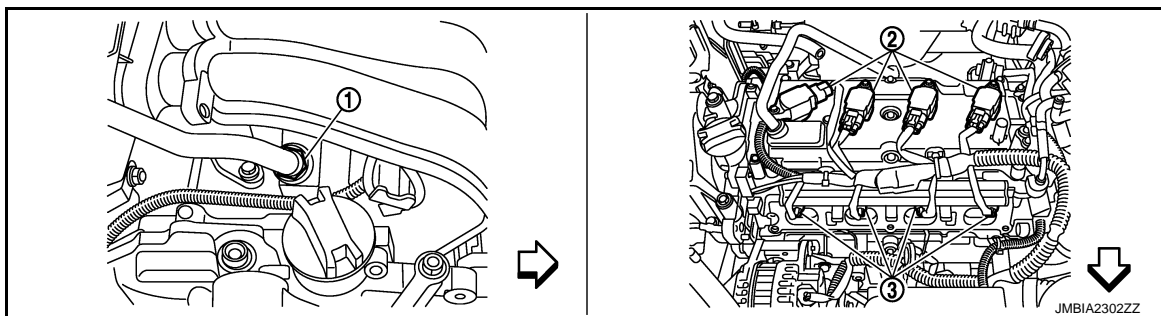

1. PCV valve
2. Ignition coil (with power transistor)
3. Fuel injector

← Vehicle front

A

EC

C

D

E

F

G

H

I

J

K

L

M

N

O

P

MULTIPOINT FUEL INJECTION SYSTEM

< SYSTEM DESCRIPTION >

[MR18DE]

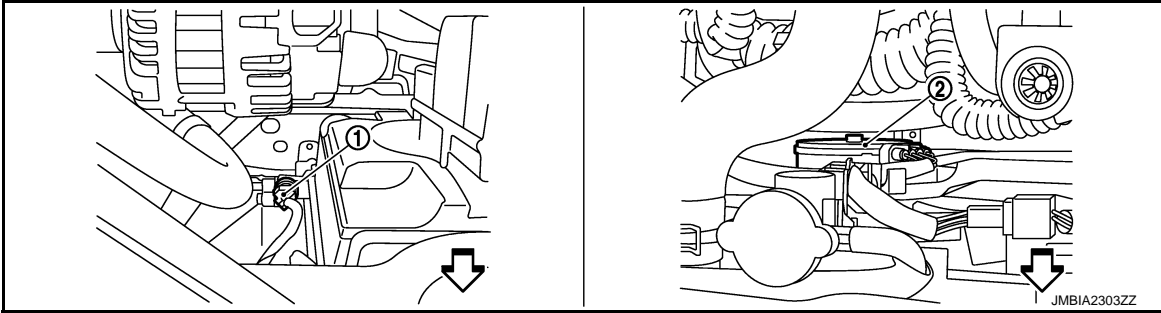

- 1. Refrigerant pressure sensor
- 2. Cooling fan motor

↶ Vehicle front

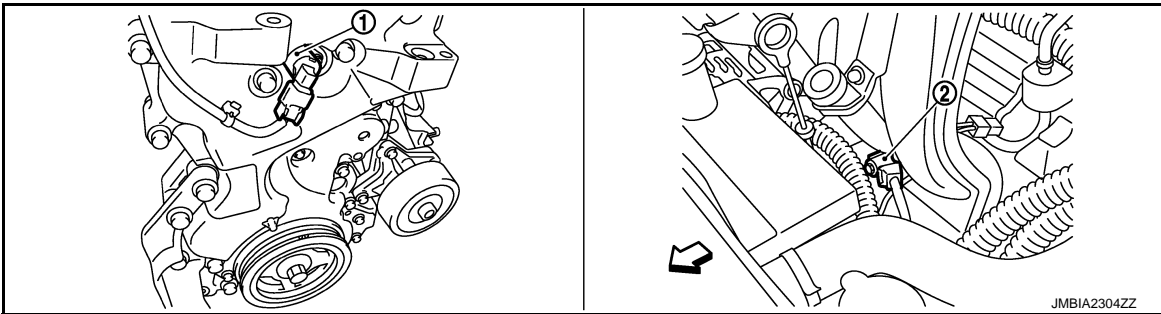

- 1. Intake valve timing control solenoid
- 2. Knock sensor valve

↶ Vehicle front

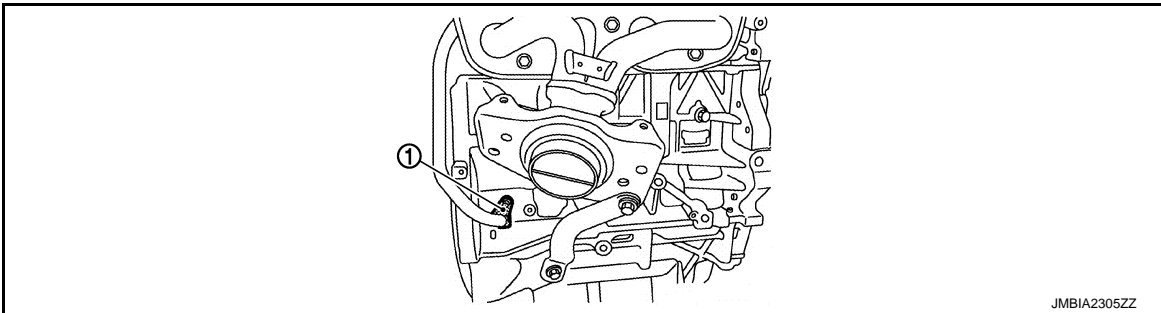

- 1. Crankshaft position sensor (POS)

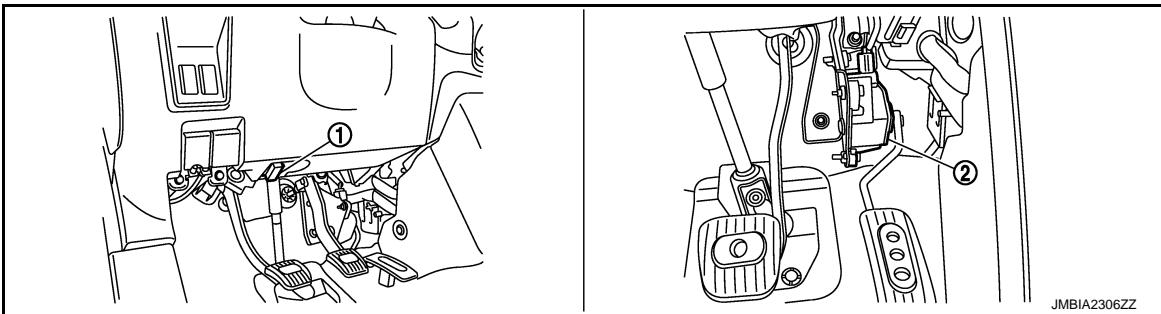

- 1. Data link connector
- 2. Accelerator pedal position sensor

MULTIPOINT FUEL INJECTION SYSTEM

< SYSTEM DESCRIPTION >

[MR18DE]

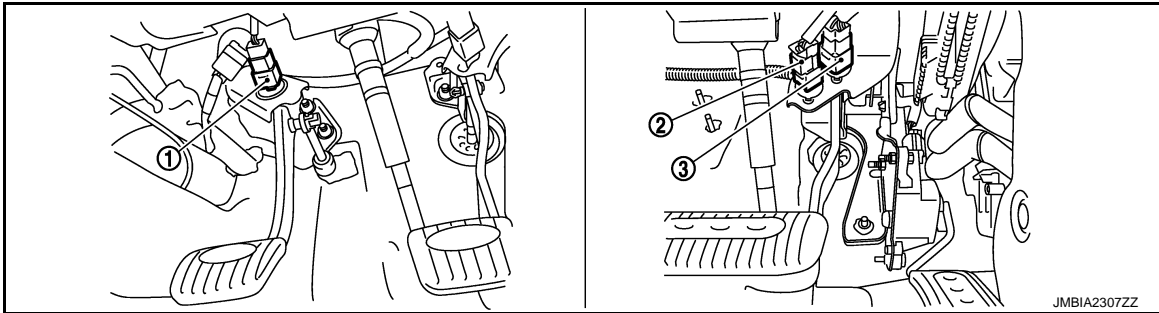

- 1. ASCD clutch switch
- 2. ASCD brake switch
- 3. Stop lamp switch

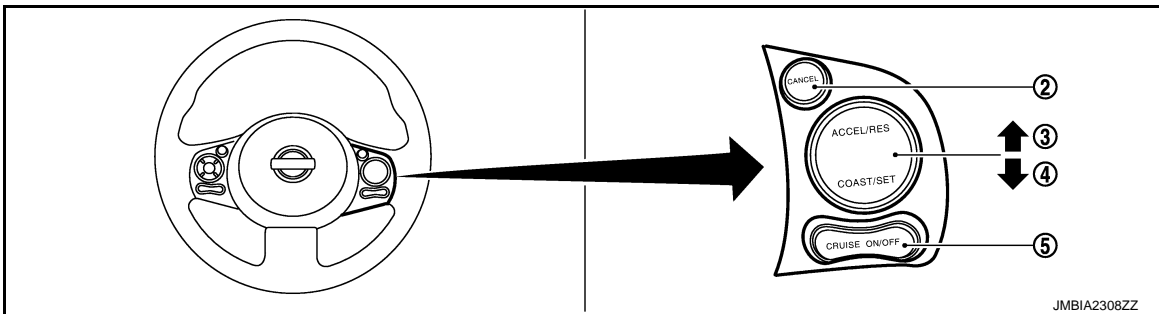

- 1. ASCD steering switch
- 2. CANCEL switch
- 3. RESUME/ACCELERATE switch
- 4. SET/COST switch
- 5. MAIN switch

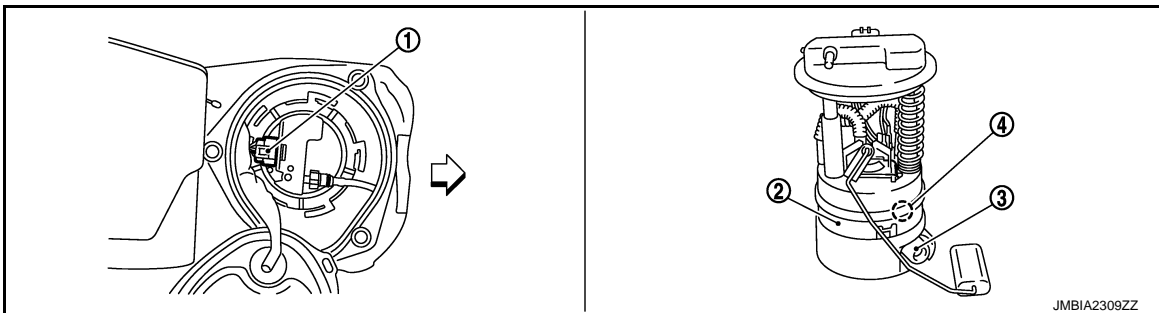

- 1. Fuel level sensor unit and fuel pump
- 2. Fuel level sensor unit and fuel pump harness connector
- 3. Fuel pressure regulator
- 4. Fuel tank temperature sensor

↶ Vehicle front

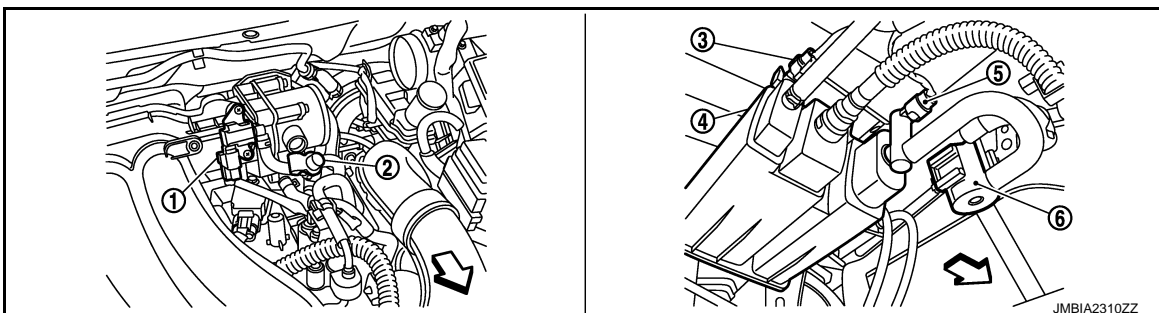

- 1. EVAP canister purge volume control
- 2. EVAP service port solenoid valve
- 3. EVAP control system pressure sensor

A
EC
C
D
E
F
G
H
I
J
K
L
M
N
O
P

MULTIPOINT FUEL INJECTION SYSTEM

[MR18DE]

< SYSTEM DESCRIPTION >

4. EVAP canister 5. EVAP canister vent control valve 6. Drain filter
↳ Vehicle front

Component Description

INFOID:000000004833166

Component	Reference
A/F sensor 1	EC-165. "Description"
Accelerator pedal position sensor	EC-368. "Description"
Camshaft position sensor (PHASE)	EC-229. "Description"
Crankshaft position sensor (POS)	EC-225. "Description"
Engine coolant temperature sensor	EC-152. "Description"
Fuel injector	EC-395. "Description"
Heated oxygen sensor 2	EC-180. "Description"
Intake air temperature sensor	EC-148. "Description"
Knock sensor	EC-223. "Description"
Mass air flow sensor	EC-136. "Description"
Park/neutral position switch	EC-310. "Description"
Throttle position sensor	EC-155. "Description"

ELECTRIC IGNITION SYSTEM

System Diagram

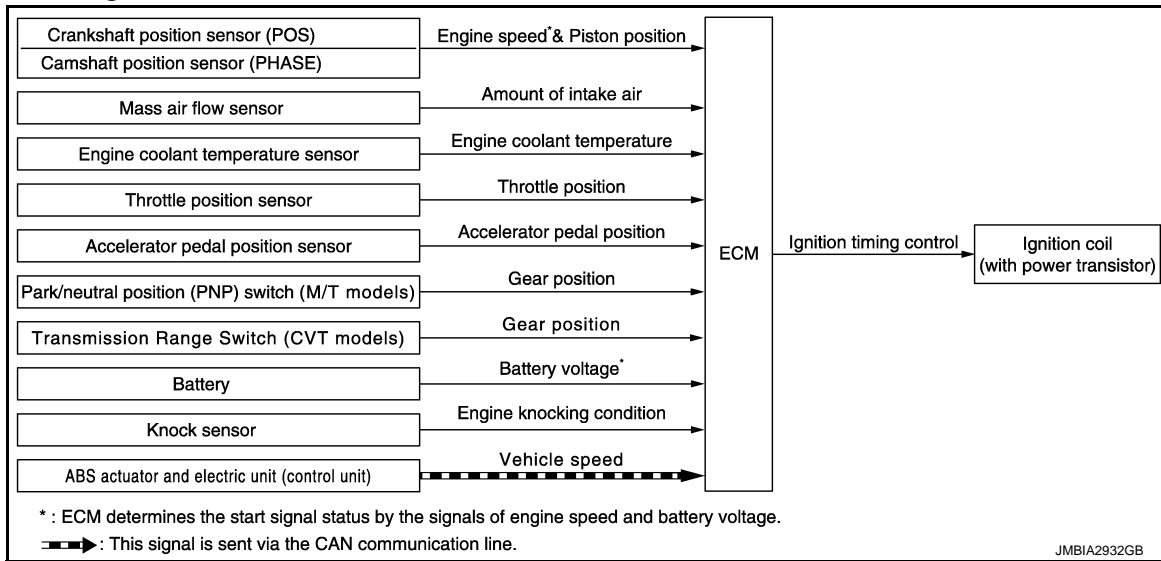

System Description

INFOID:000000004833168

INPUT/OUTPUT SIGNAL CHART

Sensor	Input signal to ECM	ECM function	Actuator
Crankshaft position sensor (POS)	Engine speed*2 Piston position	Ignition timing control	Ignition coil (with power transistor)
Camshaft position sensor (PHASE)			
Mass air flow sensor	Amount of intake air		
Engine coolant temperature sensor	Engine coolant temperature		
Throttle position sensor	Throttle position		
Accelerator pedal position sensor	Accelerator pedal position		
Battery	Battery voltage*2		
Knock sensor	Engine knocking		
Park/neutral position (PNP) switch (M/T models)	Gear position		
Transmission range switch (CVT models)	Gear position		
ABS actuator and electric unit (control unit)	Vehicle speed*1		

*1: This signal is sent to the ECM via the CAN communication line.

*2: ECM determines the start signal status by the signals of engine speed and battery voltage.

SYSTEM DESCRIPTION

Ignition order: 1 - 3 - 4 - 2

The ignition timing is controlled by the ECM to maintain the best air-fuel ratio for every running condition of the engine. The ignition timing data is stored in the ECM.

The ECM receives information such as the injection pulse width and camshaft position sensor (PHASE) signal. Computing this information, ignition signals are transmitted to the power transistor.

During the following conditions, the ignition timing is revised by the ECM according to the other data stored in the ECM.

- At starting
- During warm-up
- At idle
- At low battery voltage
- During acceleration

ELECTRIC IGNITION SYSTEM

[MR18DE]

< SYSTEM DESCRIPTION >

The knock sensor retard system is designed only for emergencies. The basic ignition timing is programmed within the anti-knocking zone, if recommended fuel is used under dry conditions. The retard system does not operate under normal driving conditions. If engine knocking occurs, the knock sensor monitors the condition. The signal is transmitted to the ECM. The ECM retards the ignition timing to eliminate the knocking condition.

Component Parts Location

INFOID:000000004833169

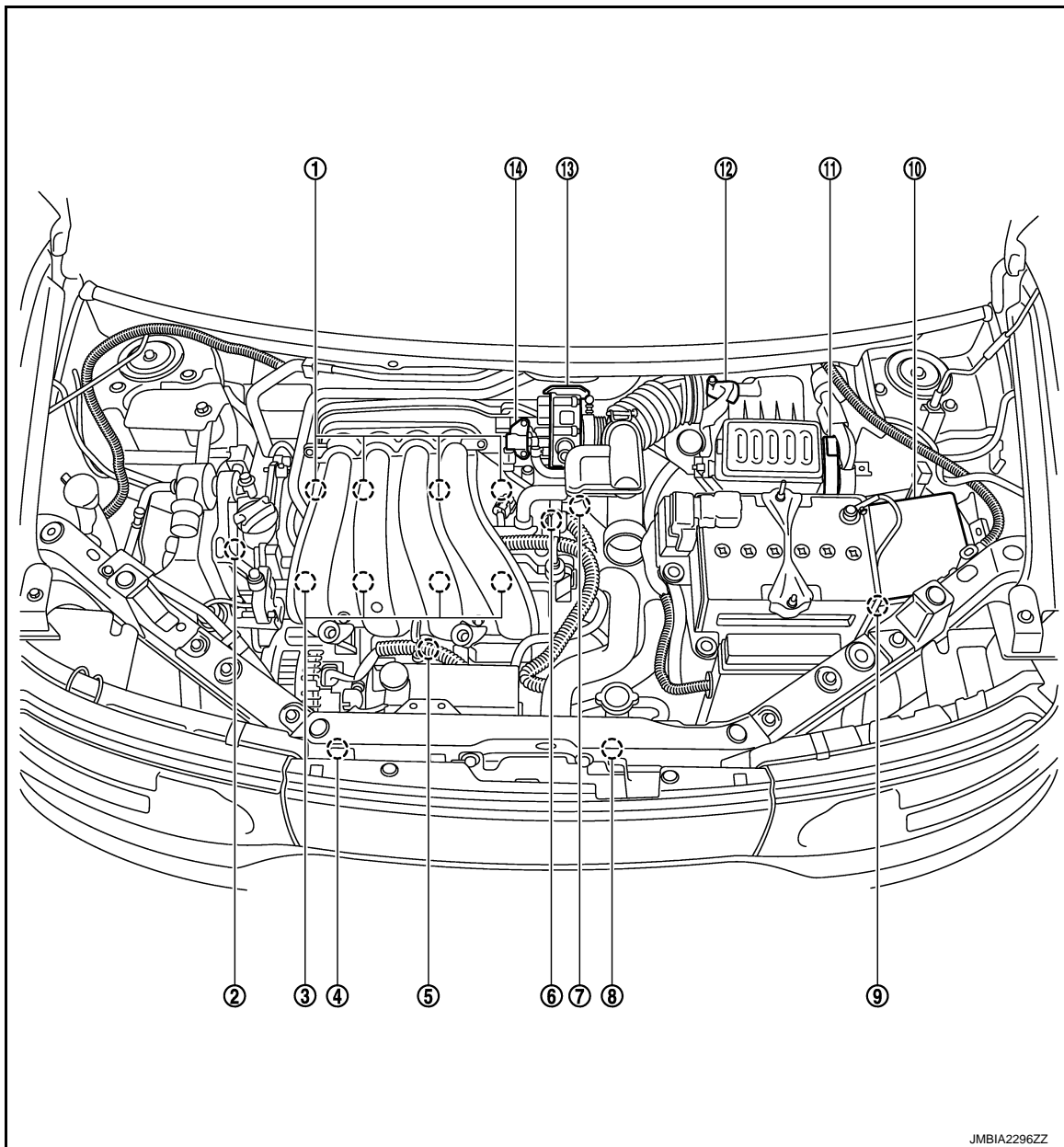

- | | | |
|--|---|---|
| 1. Ignition coil (with power transistor) and spark plug | 2. Intake valve timing control solenoid valve | 3. Fuel injector |
| 4. Refrigerant pressure sensor | 5. Knock sensor | 6. Camshaft position sensor (PHASE) |
| 7. Engine coolant temperature sensor | 8. Cooling fan motor | 9. Battery current sensor |
| 10. IPDM E/R | 11. ECM | 12. Mass air flow sensor (with intake air temperature sensor) |
| 13. Electric throttle control actuator (with built in throttle position sensor and throttle control motor) | 14. EVAP canister purge volume control solenoid valve | |

ELECTRIC IGNITION SYSTEM

< SYSTEM DESCRIPTION >

[MR18DE]

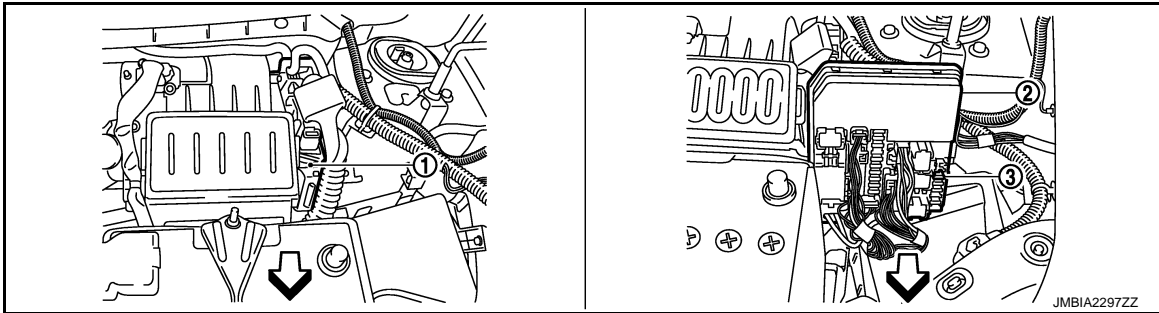

- 1. ECM
- 2. IPDM E/R
- 3. Fuel pump fuse (15 A)

← Vehicle front

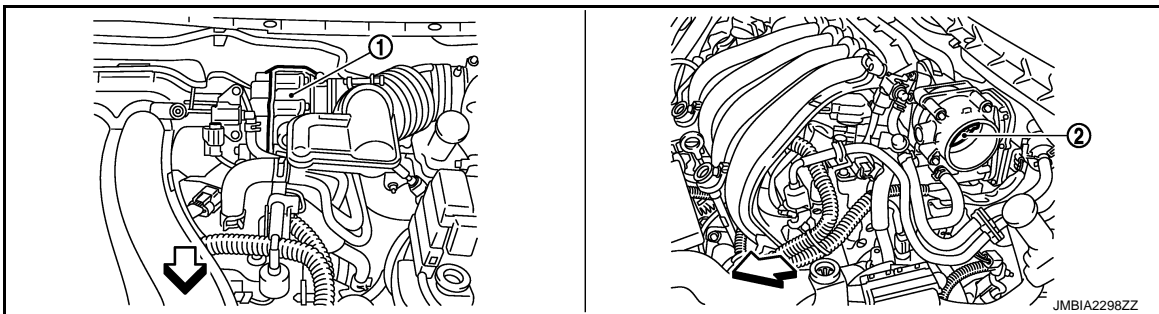

- 1. Electric throttle control actuator (with built-in position sensor, throttle control motor)
- 2. Throttle valve

← Vehicle front

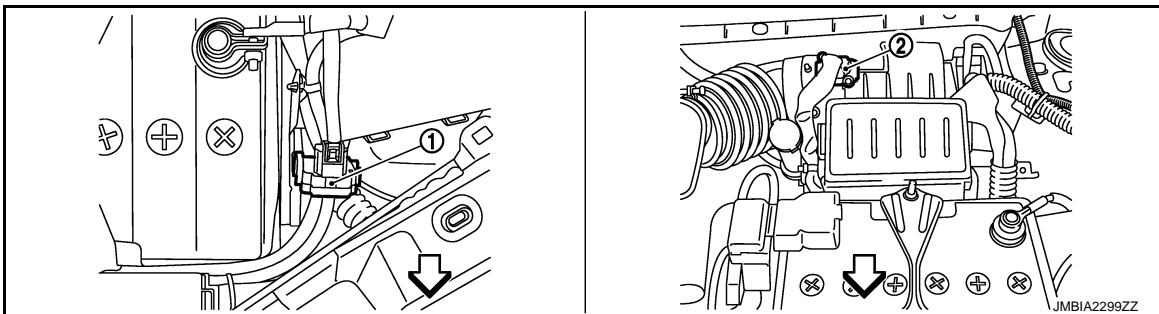

- 1. Battery current sensor
- 2. Mass air flow sensor (with Intake air temperature sensor)

← Vehicle front

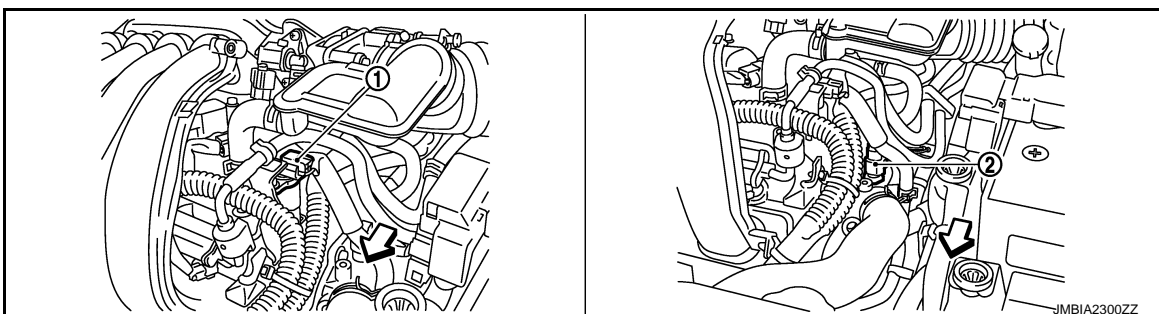

A
EC
C
D
E
F
G
H
I
J
K
L
M
N
O
P

ELECTRIC IGNITION SYSTEM

[MR18DE]

< SYSTEM DESCRIPTION >

1. Camshaft position sensor (PHASE)
2. Engine coolant temperature sensor

↶ Vehicle front

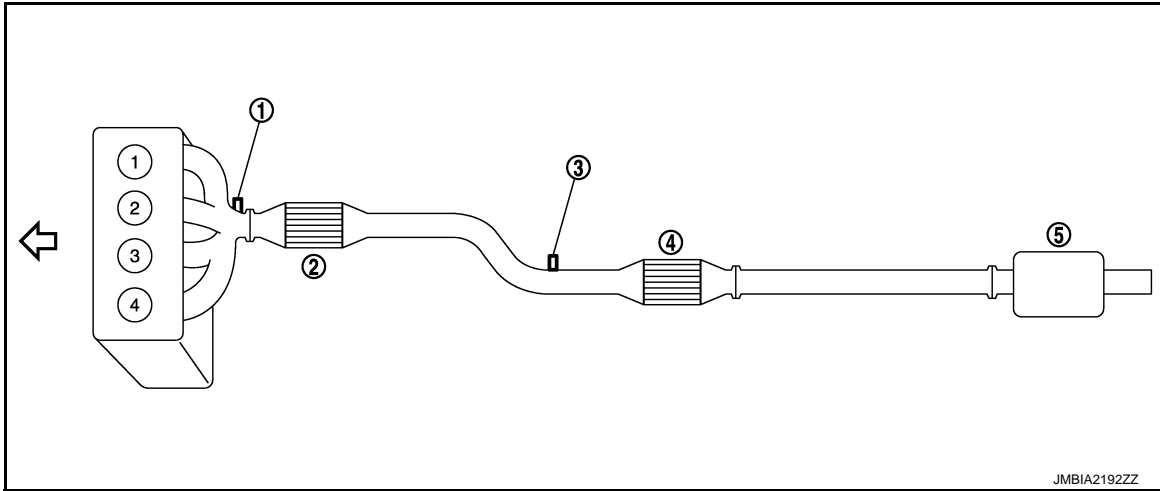

JMBIA2192ZZ

1. Air fuel ratio (A/F) sensor 1
2. Three way catalyst (Manifold)
3. Heated oxygen sensor 2
4. Three way catalyst (under floor)
5. Muffler

↶ Vehicle front



JMBIA2301ZZ

1. Air fuel ratio (A/F) sensor 1 harness
2. Air fuel ratio (A/F) sensor 1 connector
3. Heated oxygen sensor 2
4. Heated oxygen sensor 2 harness connector

↶ Vehicle front

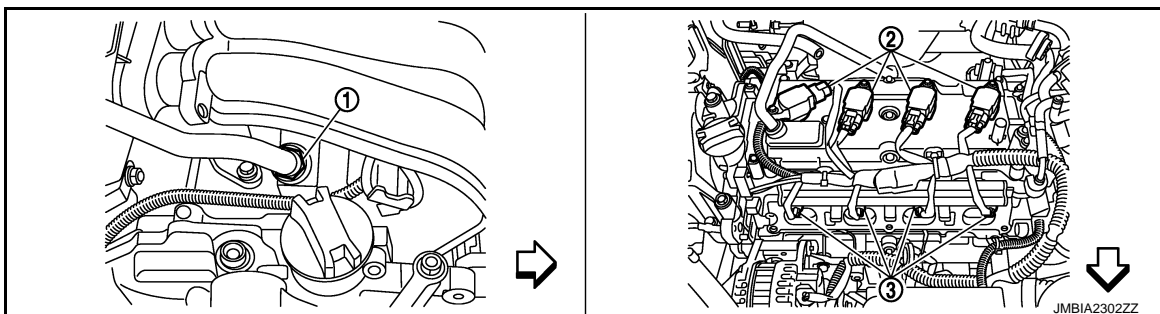

JMBIA2302ZZ

1. PCV valve
2. Ignition coil (with power transistor)
3. Fuel injector

↶ Vehicle front

ELECTRIC IGNITION SYSTEM

< SYSTEM DESCRIPTION >

[MR18DE]

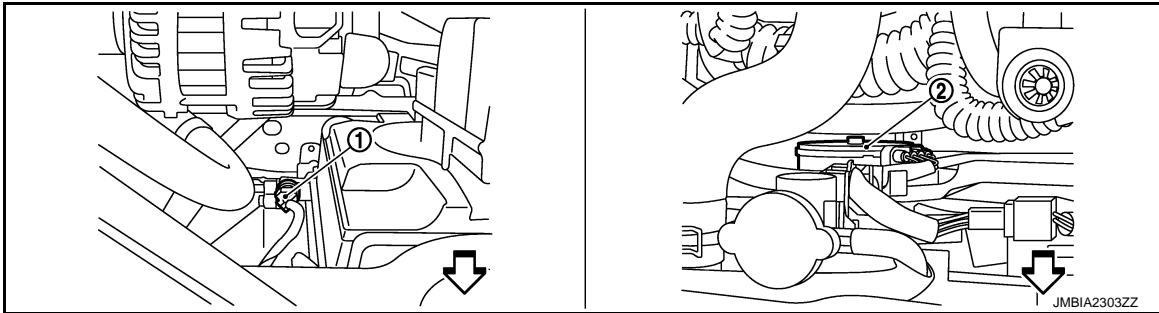

- 1. Refrigerant pressure sensor
- 2. Cooling fan motor

← Vehicle front

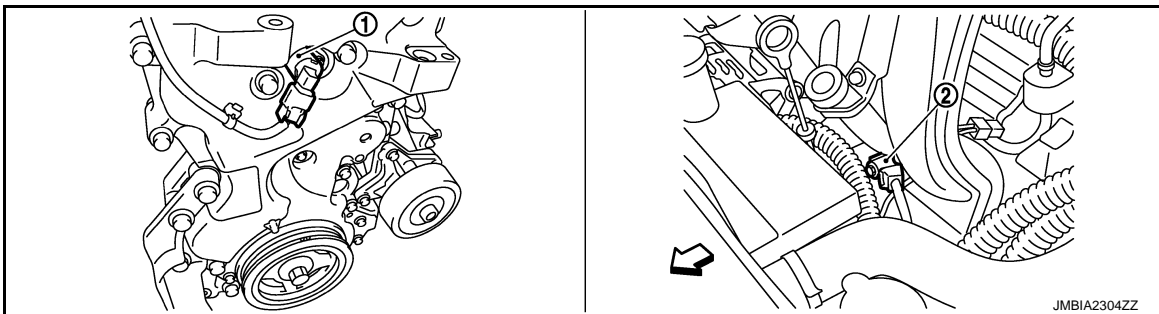

- 1. Intake valve timing control solenoid
- 2. Knock sensor valve

← Vehicle front

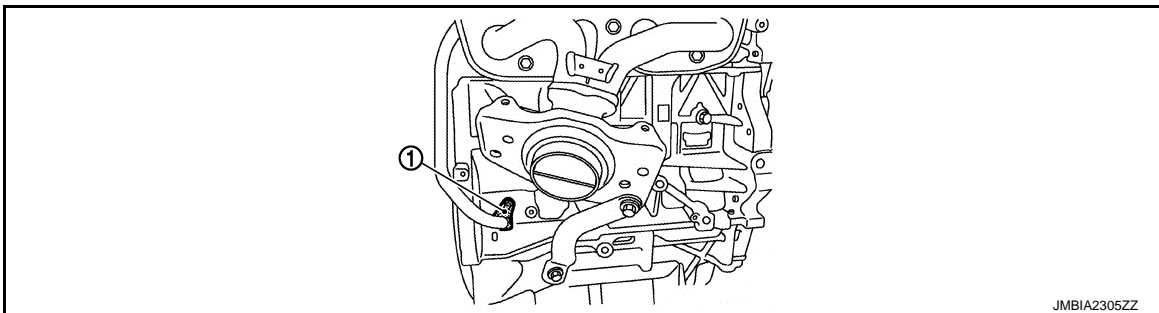

- 1. Crankshaft position sensor (POS)

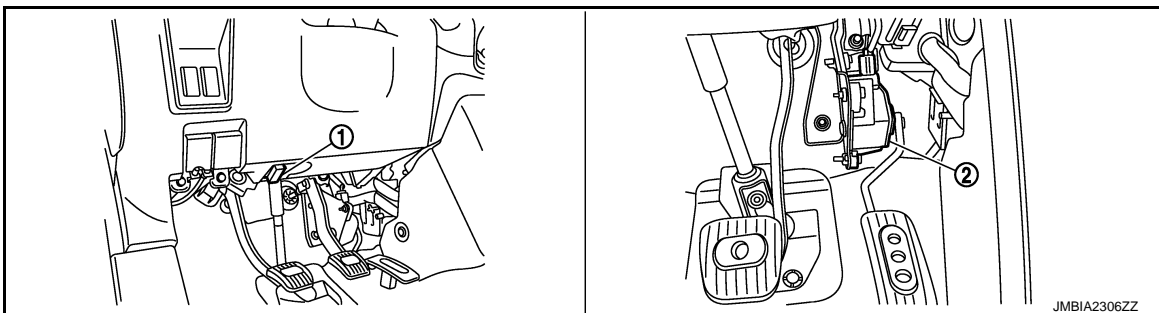

- 1. Data link connector
- 2. Accelerator pedal position sensor

A
EC
C
D
E
F
G
H
I
J
K
L
M
N
O
P

ELECTRIC IGNITION SYSTEM

< SYSTEM DESCRIPTION >

[MR18DE]

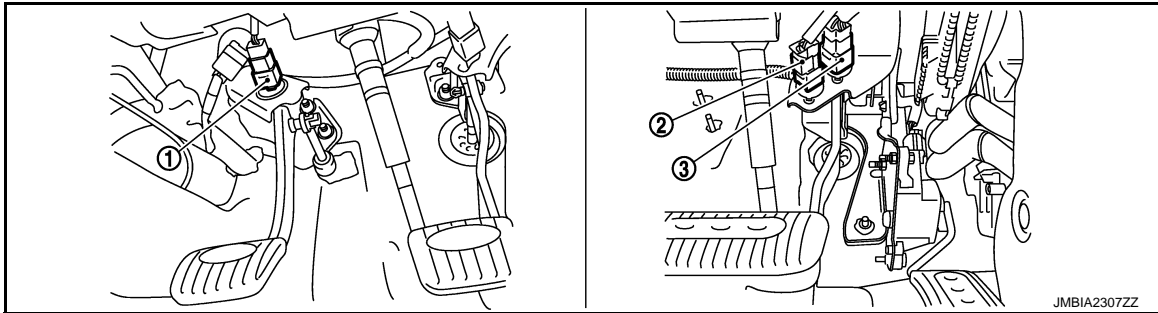

- 1. ASCD clutch switch
- 2. ASCD brake switch
- 3. Stop lamp switch

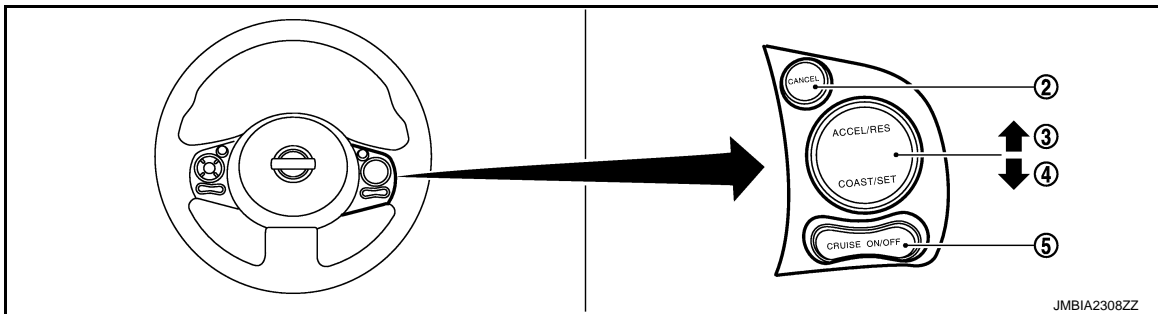

- 1. ASCD steering switch
- 2. CANCEL switch
- 3. RESUME/ACCELERATE switch
- 4. SET/COST switch
- 5. MAIN switch

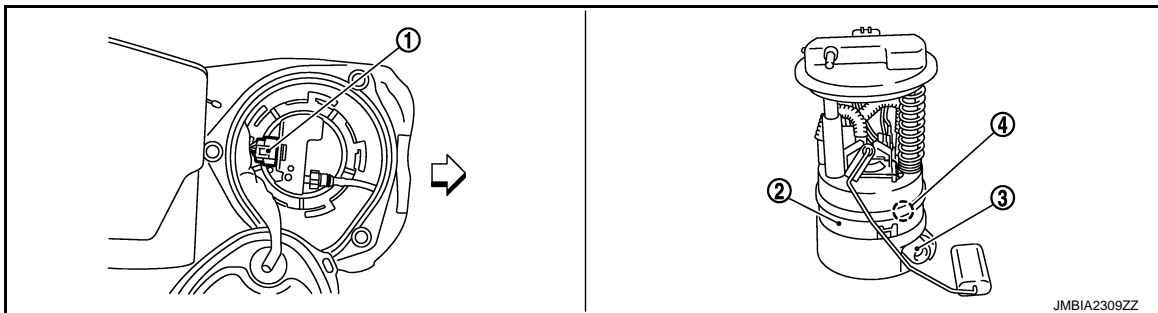

- 1. Fuel level sensor unit and fuel pump
 - 2. Fuel level sensor unit and fuel pump harness connector
 - 3. Fuel pressure regulator
 - 4. Fuel tank temperature sensor
- ↙ Vehicle front

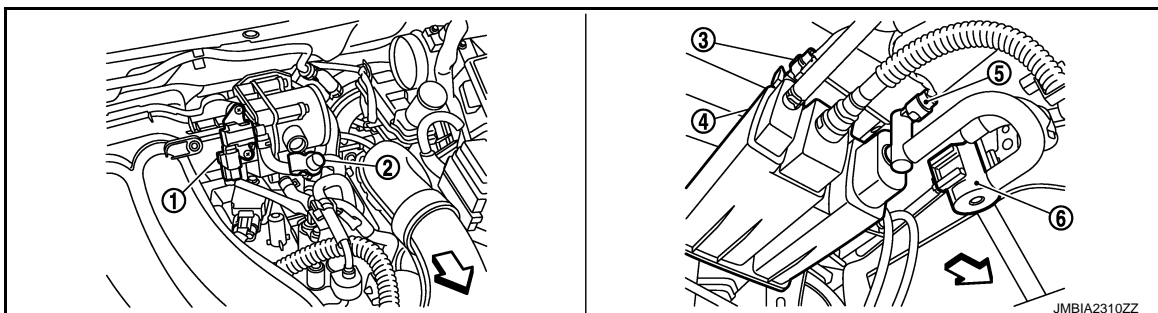

- 1. EVAP canister purge volume control
- 2. EVAP service port solenoid valve
- 3. EVAP control system pressure sensor

ELECTRIC IGNITION SYSTEM

[MR18DE]

< SYSTEM DESCRIPTION >

- 4. EVAP canister
 - 5. EVAP canister vent control valve
 - 6. Drain filter
- ↶ Vehicle front

A

Component Description

INFOID:000000004833170

EC

Component	Reference
Accelerator pedal position sensor	EC-368. "Description"
Camshaft position sensor (PHASE)	EC-229. "Description"
Crankshaft position sensor (POS)	EC-225. "Description"
Engine coolant temperature sensor	EC-152. "Description"
Ignition signal	EC-401. "Description"
Knock sensor	EC-223. "Description"
Mass air flow sensor	EC-136. "Description"
Park/neutral position switch	EC-310. "Description"
Throttle position sensor	EC-155. "Description"
Vehicle speed sensor	EC-299. "Description"

C

D

E

F

G

H

I

J

K

L

M

N

O

P

AIR CONDITIONING CUT CONTROL

[MR18DE]

< SYSTEM DESCRIPTION >

AIR CONDITIONING CUT CONTROL

System Diagram

INFOID:000000004833171

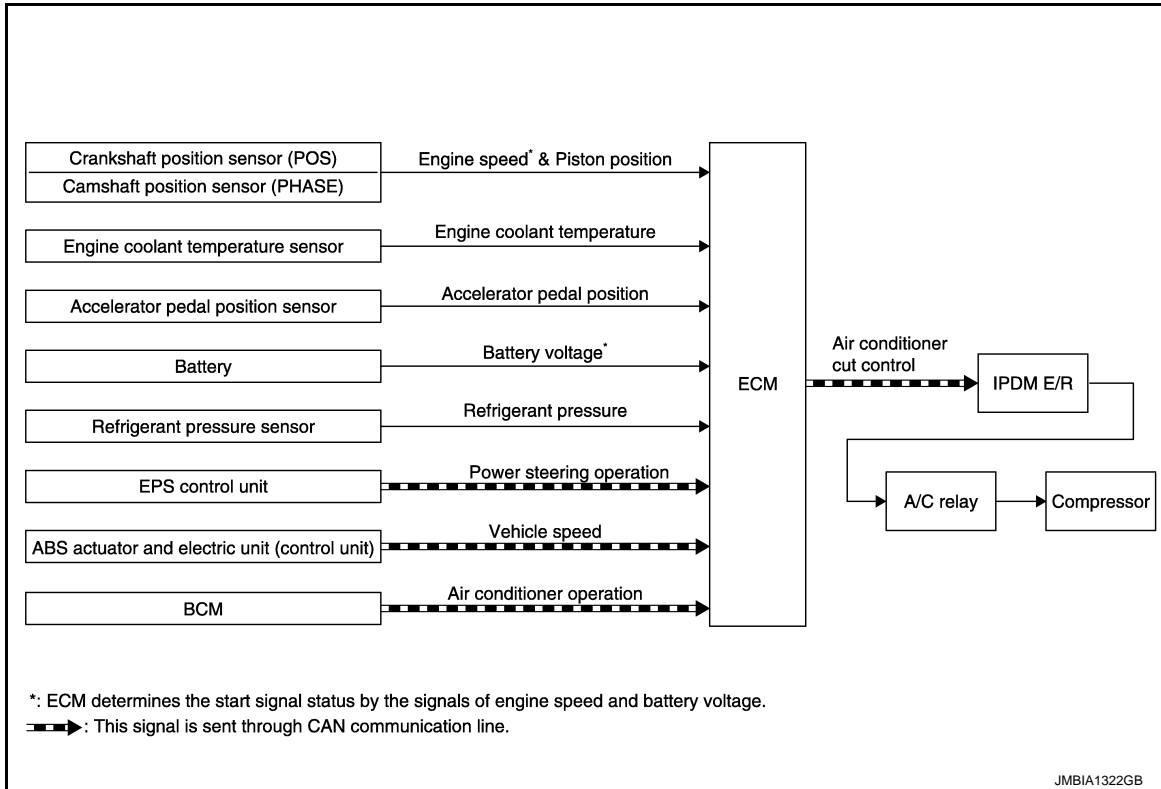

System Description

INFOID:000000004833172

INPUT/OUTPUT SIGNAL CHART

Sensor	Input Signal to ECM	ECM function	Actuator
Air conditioner switch*1	Air conditioner ON signal	Air conditioner cut control	IPDM E/R ↓ Air conditioner relay ↓ Compressor
Accelerator pedal position sensor	Accelerator pedal position		
Crankshaft position sensor (POS) Camshaft position sensor (PHASE)	Engine speed*2		
Engine coolant temperature sensor	Engine coolant temperature		
Battery	Battery voltage*2		
Refrigerant pressure sensor	Refrigerant pressure		
EPS control unit	Power steering operation		
ABS actuator and electric unit (control unit)	Vehicle speed*1		
BCM	Air conditioner ON signal*1		

*1: This signal is sent to the ECM via the CAN communication line.

*2: ECM determines the start signal status by the signals of engine speed and battery voltage.

SYSTEM DESCRIPTION

This system improves engine operation when the air conditioner is used. Under the following conditions, the air conditioner is turned off.

- When the accelerator pedal is fully depressed.
- When cranking the engine.
- At high engine speeds.
- When the engine coolant temperature becomes excessively high.
- When operating power steering during low engine speed or low vehicle speed.

AIR CONDITIONING CUT CONTROL

[MR18DE]

< SYSTEM DESCRIPTION >

- When engine speed is excessively low.
- When refrigerant pressure is excessively low or high.

Component Parts Location

INFOID:000000004833173

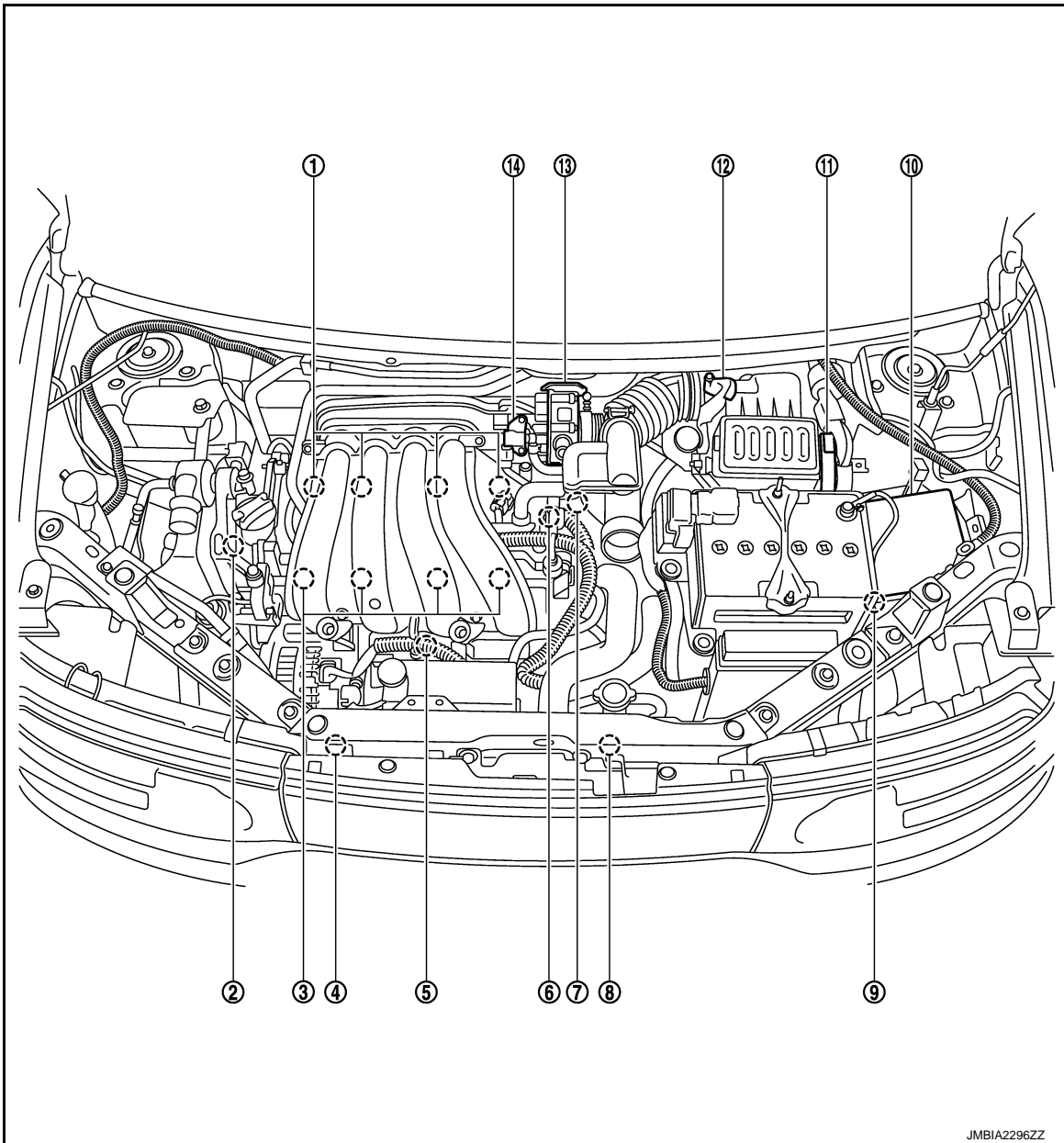

- | | | |
|--|---|---|
| 1. Ignition coil (with power transistor) and spark plug | 2. Intake valve timing control solenoid valve | 3. Fuel injector |
| 4. Refrigerant pressure sensor | 5. Knock sensor | 6. Camshaft position sensor (PHASE) |
| 7. Engine coolant temperature sensor | 8. Cooling fan motor | 9. Battery current sensor |
| 10. IPDM E/R | 11. ECM | 12. Mass air flow sensor (with intake air temperature sensor) |
| 13. Electric throttle control actuator (with built in throttle position sensor and throttle control motor) | 14. EVAP canister purge volume control solenoid valve | |

AIR CONDITIONING CUT CONTROL

< SYSTEM DESCRIPTION >

[MR18DE]

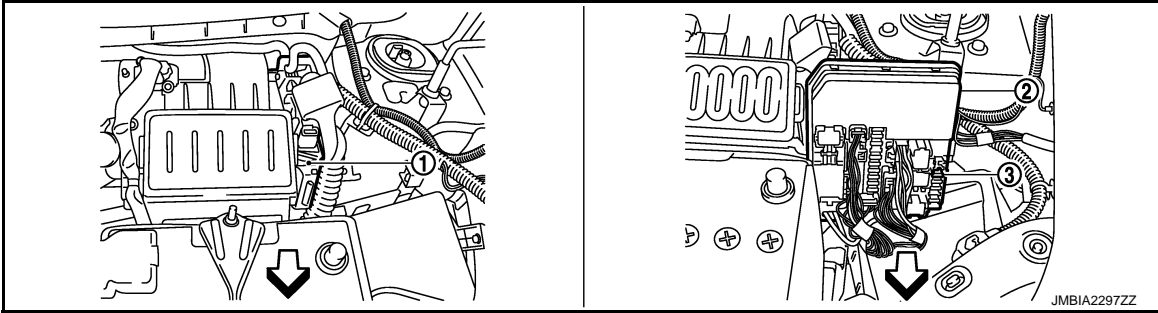

1. ECM 2. IPDM E/R 3. Fuel pump fuse (15 A)
- ← Vehicle front

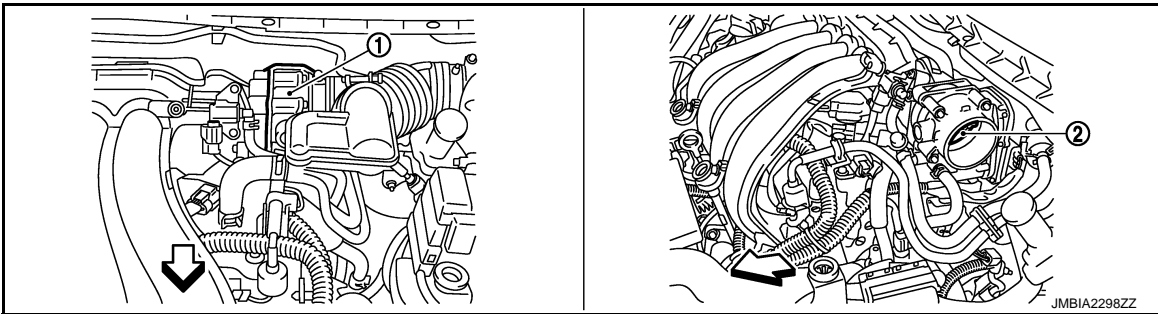

1. Electric throttle control actuator 2. Throttle valve
(with built-in position sensor, throttle control motor)
- ← Vehicle front

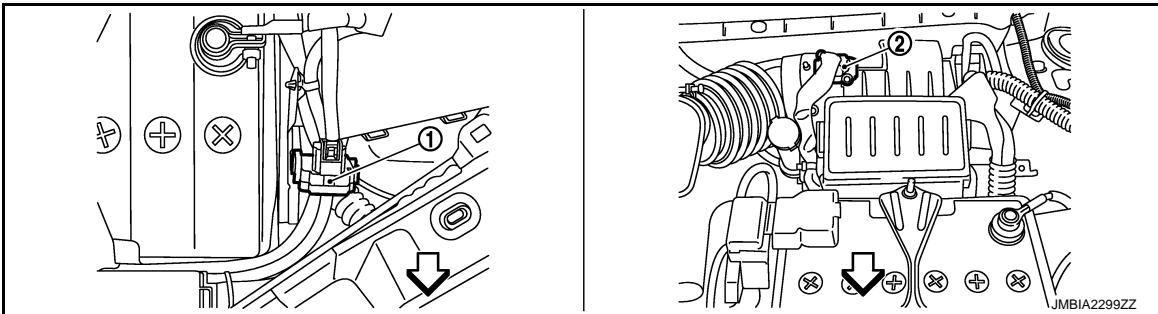

1. Battery current sensor 2. Mass air flow sensor
(with Intake air temperature sensor)
- ← Vehicle front

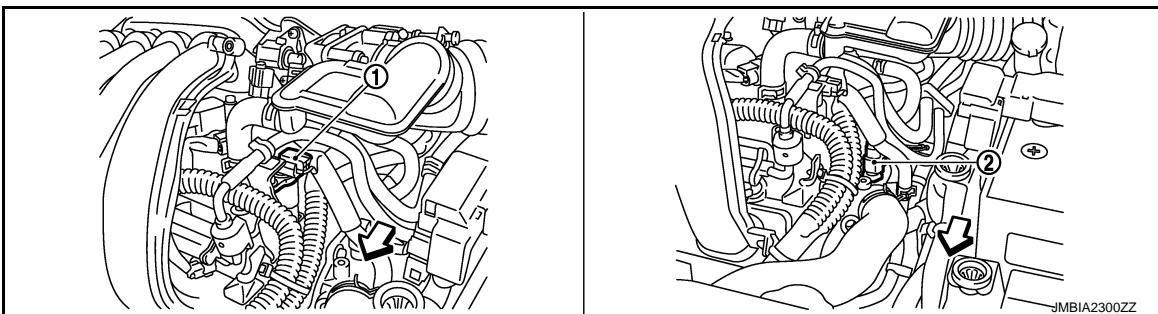

AIR CONDITIONING CUT CONTROL

[MR18DE]

< SYSTEM DESCRIPTION >

1. Camshaft position sensor (PHASE)
2. Engine coolant temperature sensor

← Vehicle front

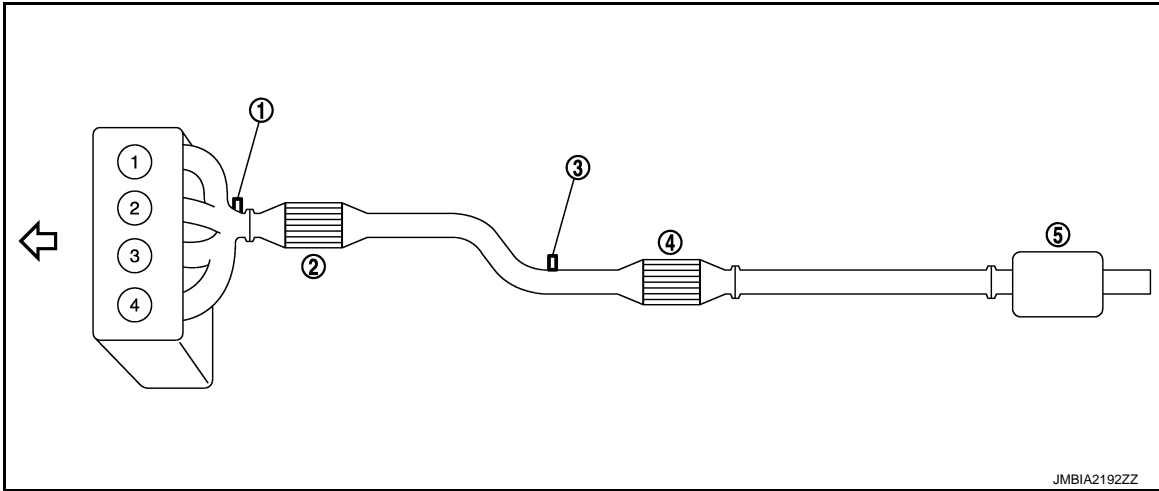

1. Air fuel ratio (A/F) sensor 1
2. Three way catalyst (Manifold)
3. Heated oxygen sensor 2
4. Three way catalyst (under floor)
5. Muffler

← Vehicle front

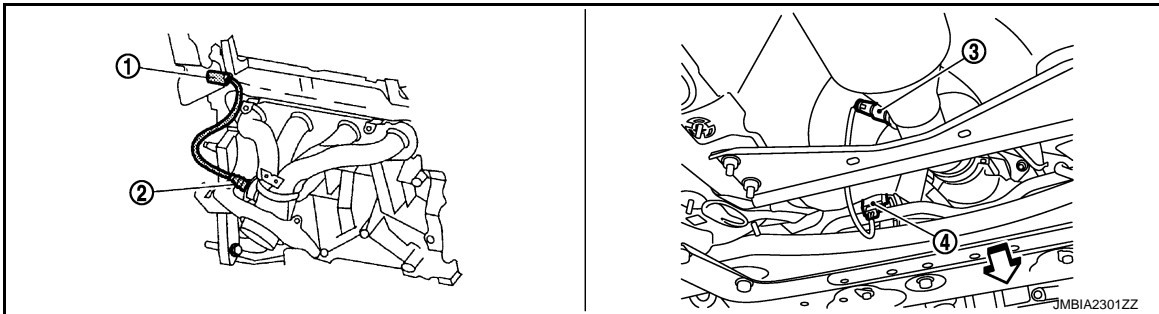

1. Air fuel ratio (A/F) sensor 1 harness
2. Air fuel ratio (A/F) sensor 1 connector
3. Heated oxygen sensor 2
4. Heated oxygen sensor 2 harness connector

← Vehicle front

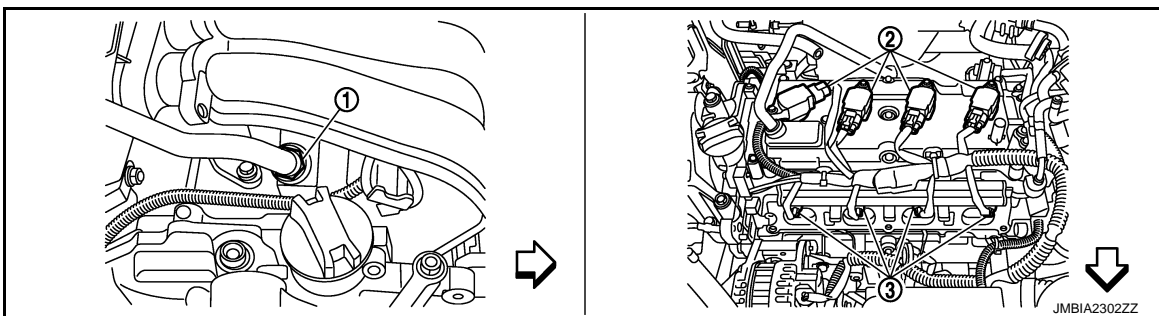

1. PCV valve
2. Ignition coil (with power transistor)
3. Fuel injector

← Vehicle front

A

EC

C

D

E

F

G

H

I

J

K

L

M

N

O

P

AIR CONDITIONING CUT CONTROL

< SYSTEM DESCRIPTION >

[MR18DE]

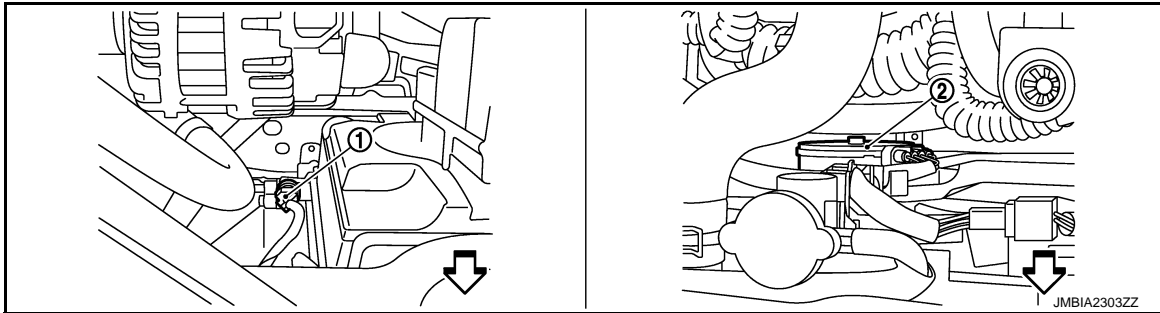

- 1. Refrigerant pressure sensor
- 2. Cooling fan motor

↶ Vehicle front

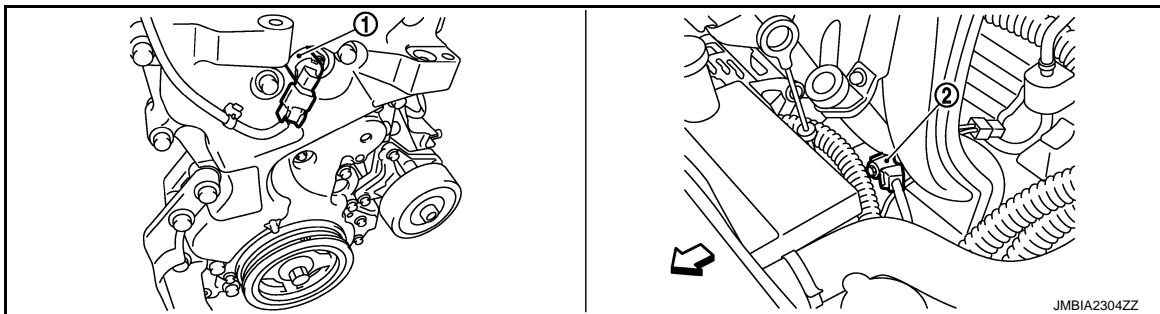

- 1. Intake valve timing control solenoid
- 2. Knock sensor valve

↶ Vehicle front

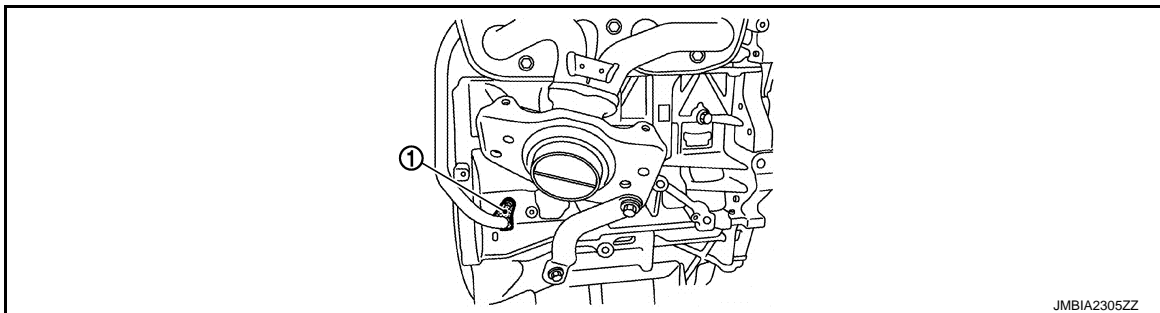

- 1. Crankshaft position sensor (POS)

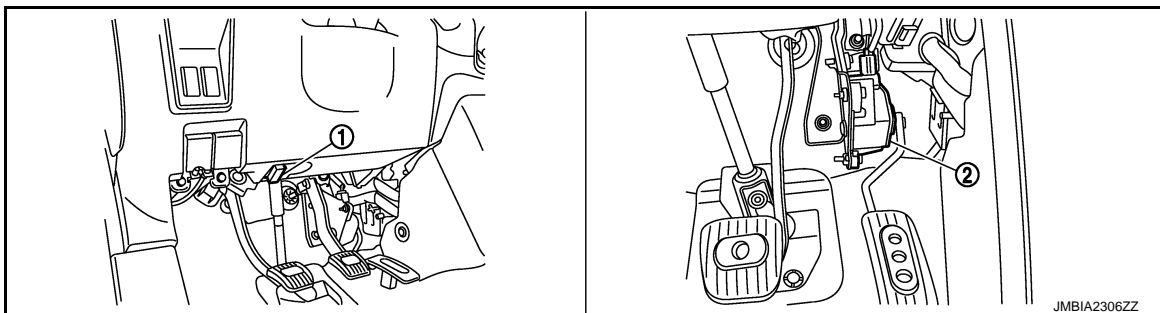

- 1. Data link connector
- 2. Accelerator pedal position sensor

AIR CONDITIONING CUT CONTROL

< SYSTEM DESCRIPTION >

[MR18DE]

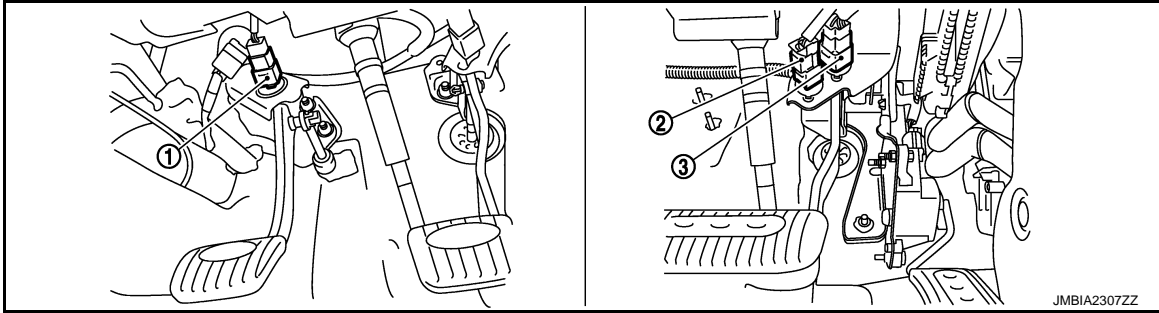

- 1. ASCD clutch switch
- 2. ASCD brake switch
- 3. Stop lamp switch

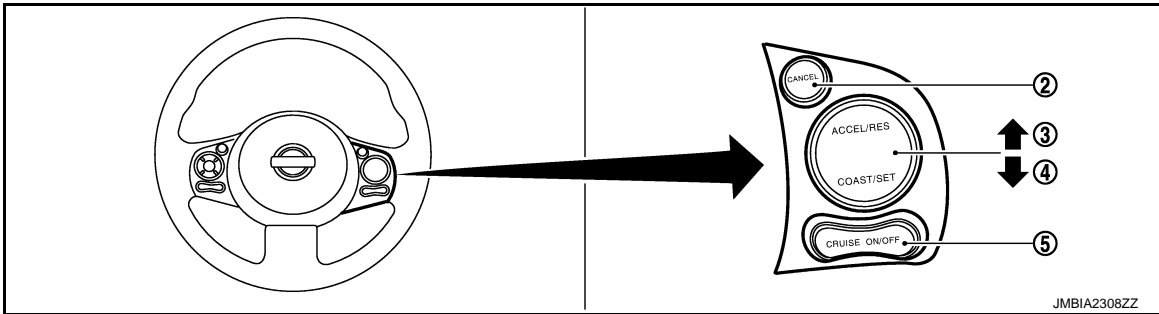

- 1. ASCD steering switch
- 2. CANCEL switch
- 3. RESUME/ACCELERATE switch
- 4. SET/COST switch
- 5. MAIN switch

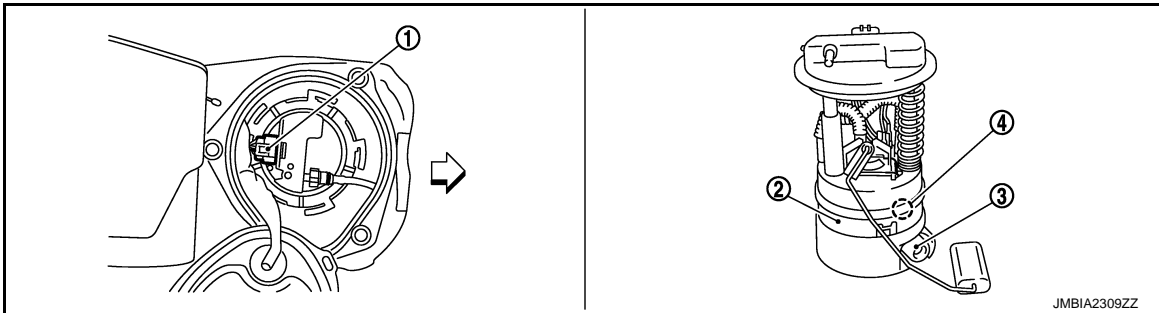

- 1. Fuel level sensor unit and fuel pump
 - 2. Fuel level sensor unit and fuel pump
 - 3. Fuel pressure regulator harness connector
 - 4. Fuel tank temperature sensor
- ↶ Vehicle front

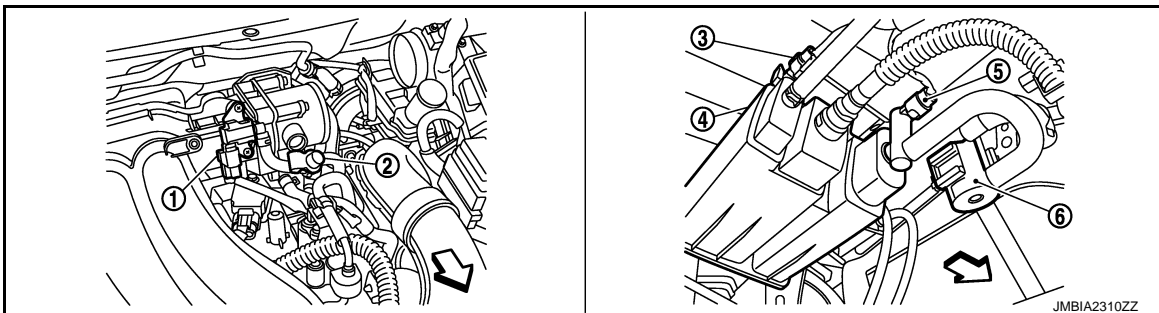

- 1. EVAP canister purge volume control
- 2. EVAP service port solenoid valve
- 3. EVAP control system pressure sensor

A
EC
C
D
E
F
G
H
I
J
K
L
M
N
O
P

AIR CONDITIONING CUT CONTROL

[MR18DE]

< SYSTEM DESCRIPTION >

- 4. EVAP canister
 - 5. EVAP canister vent control valve
 - 6. Drain filter
- ↶ Vehicle front

Component Description

INFOID:000000004833174

Component	Reference
Accelerator pedal position sensor	EC-368. "Description"
Camshaft position sensor (PHASE)	EC-229. "Description"
Crankshaft position sensor (POS)	EC-225. "Description"
Engine coolant temperature sensor	EC-152. "Description"
Refrigerant pressure sensor	EC-414. "Description"

AUTOMATIC SPEED CONTROL DEVICE (ASCD)

< SYSTEM DESCRIPTION >

[MR18DE]

AUTOMATIC SPEED CONTROL DEVICE (ASCD)

System Diagram

INFOID:000000005040365

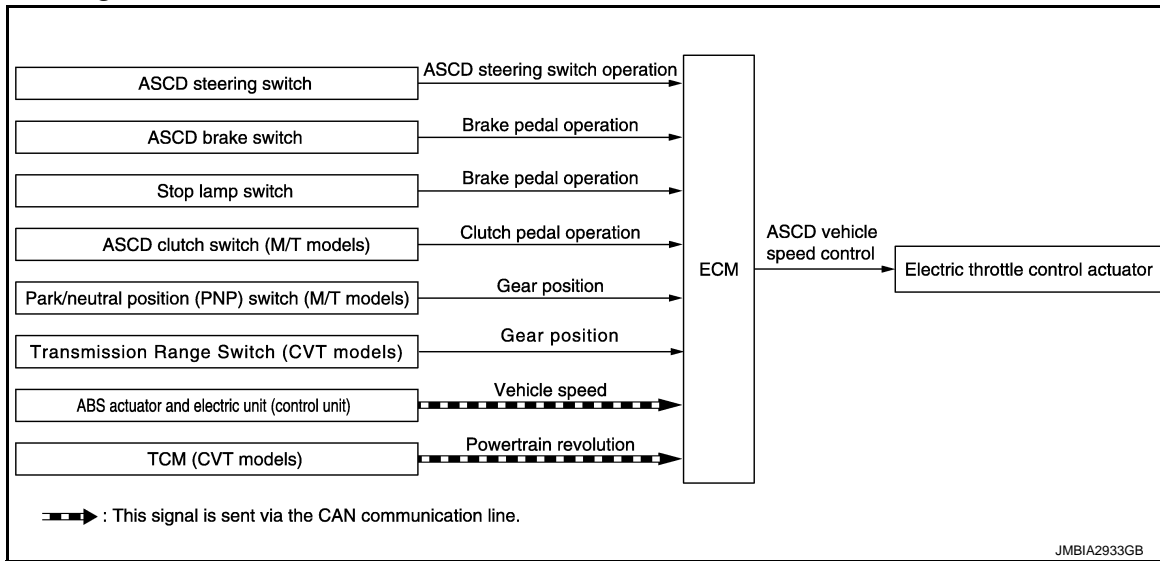

JMBIA2933GB

System Description

INFOID:000000005040364

INPUT/OUTPUT SIGNAL CHART

Sensor	Input signal to ECM	ECM function	Actuator
ASCD steering switch	ASCD steering switch operation	ASCD vehicle speed control	Electric throttle control actuator
ASCD brake switch	Brake pedal operation		
Stop lamp switch			
ASCD clutch switch (M/T models)	Clutch pedal operation		
Park/neutral position (PNP) switch (M/T models)	Gear position		
Transmission range switch (CVT models)	Gear position		
ABS actuator and electric unit (control unit)	Vehicle speed*		
TCM (M/T models)	Powertrain revolution*		

*: This signal is sent to the ECM via the CAN communication line.

BASIC ASCD SYSTEM

Refer to Owner's Manual for ASCD operating instructions.

Automatic Speed Control Device (ASCD) allows a driver to keep vehicle at predetermined constant speed without depressing accelerator pedal. Driver can set vehicle speed in advance between approximately 40 km/h (25 MPH) and 144 km/h (89 MPH).

ECM controls throttle angle of electric throttle control actuator to regulate engine speed.

Operation status of ASCD is indicated by CRUISE lamp and SET lamp in combination meter. If any malfunction occurs in the ASCD system, it automatically deactivates control.

NOTE:

Always drive vehicle in a safe manner according to traffic conditions and obey all traffic laws.

SET OPERATION

Press MAIN switch. (The CRUISE lamp in combination meter illuminates.)

When vehicle speed reaches a desired speed between approximately 40 km/h (25 MPH) and 144 km/h (89 MPH), press SET/COAST switch.

ACCELERATE OPERATION

If the RESUME/ACCELERATE switch is pressed during cruise control driving, increase the vehicle speed until the switch is released or vehicle speed reaches maximum speed controlled by the system.

And then ASCD will maintain the new set speed.

AUTOMATIC SPEED CONTROL DEVICE (ASCD)

[MR18DE]

< SYSTEM DESCRIPTION >

CANCEL OPERATION

When any of following conditions exist, cruise operation will be canceled.

- CANCEL switch is pressed
- More than 2 switches at ASCD steering switch are pressed at the same time (Set speed will be cleared)
- Brake pedal is depressed
- Clutch pedal is depressed or gear position is changed to neutral position (M/T models)
- Selector lever position is changed to N, P, R
- Vehicle speed decreased to 13 km/h (8 MPH) lower than the set speed
- TCS system is operated

When the ECM detects any of the following conditions, the ECM will cancel the cruise operation and inform the driver by blinking indicator lamp.

- Engine coolant temperature is slightly higher than the normal operating temperature, CRUISE lamp may blink slowly.

When the engine coolant temperature decreases to the normal operating temperature, CRUISE lamp will stop blinking and the cruise operation will be able to work by pressing SET/COAST switch or RESUME/ACCELERATE switch.

- Malfunction for some self-diagnoses regarding ASCD control: SET lamp will blink quickly.

If MAIN switch is turned to OFF while ASCD is activated, all of ASCD operations will be canceled and vehicle speed memory will be erased.

COAST OPERATION

When the SET/COAST switch is pressed during cruise control driving, decrease vehicle set speed until the switch is released. And then ASCD will maintain the new set speed.

RESUME OPERATION

When the RESUME/ACCELERATE switch is pressed after cancel operation other than pressing MAIN switch is performed, vehicle speed will return to last set speed. To resume vehicle set speed, vehicle condition must meet following conditions.

- Brake pedal is released
- Clutch pedal is released (M/T models)
- Selector lever position is other than P and N (CVT models)
- Vehicle speed is between 40 km/h (25 MPH) and 144 km/h (89 MPH)

AUTOMATIC SPEED CONTROL DEVICE (ASCD)

< SYSTEM DESCRIPTION >

[MR18DE]

Component Parts Location

INFOID:000000005039298

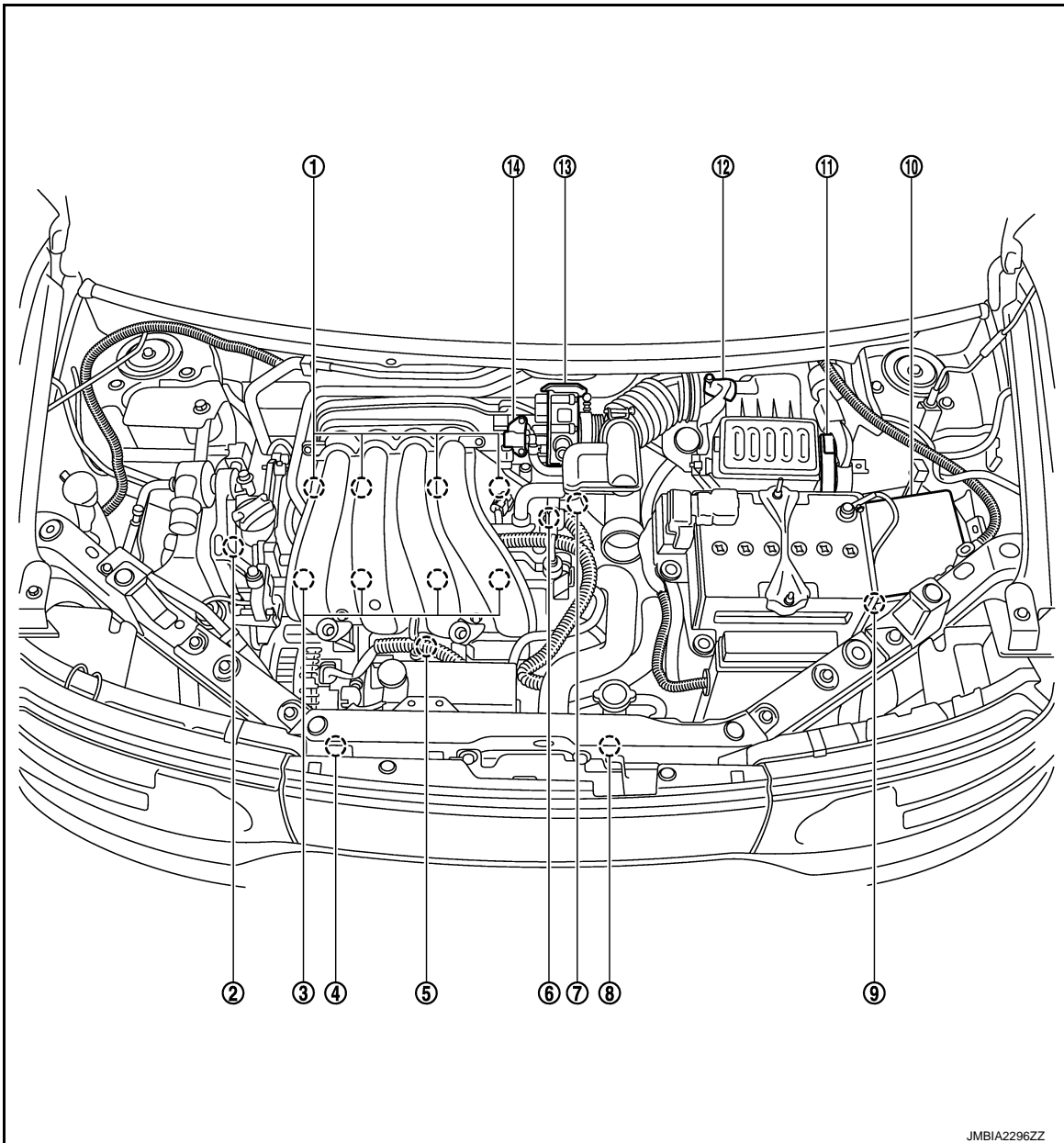

- | | | |
|--|---|---|
| 1. Ignition coil (with power transistor) and spark plug | 2. Intake valve timing control solenoid valve | 3. Fuel injector |
| 4. Refrigerant pressure sensor | 5. Knock sensor | 6. Camshaft position sensor (PHASE) |
| 7. Engine coolant temperature sensor | 8. Cooling fan motor | 9. Battery current sensor |
| 10. IPDM E/R | 11. ECM | 12. Mass air flow sensor (with intake air temperature sensor) |
| 13. Electric throttle control actuator (with built in throttle position sensor and throttle control motor) | 14. EVAP canister purge volume control solenoid valve | |

AUTOMATIC SPEED CONTROL DEVICE (ASCD)

< SYSTEM DESCRIPTION >

[MR18DE]

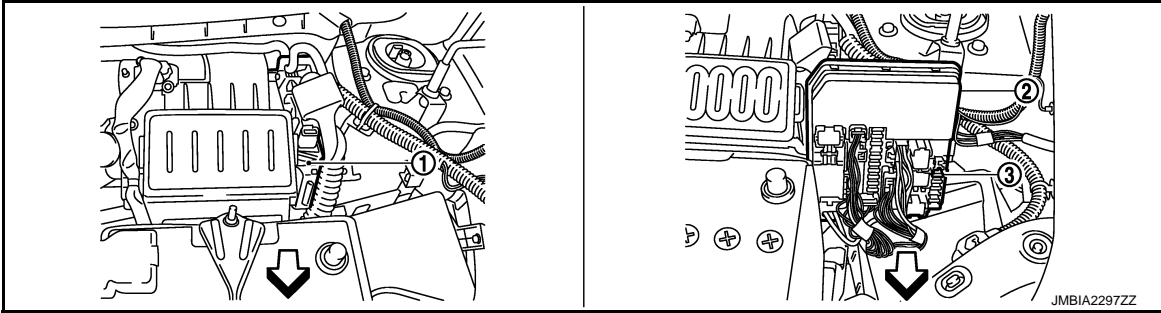

- 1. ECM
- 2. IPDM E/R
- 3. Fuel pump fuse (15 A)

← Vehicle front

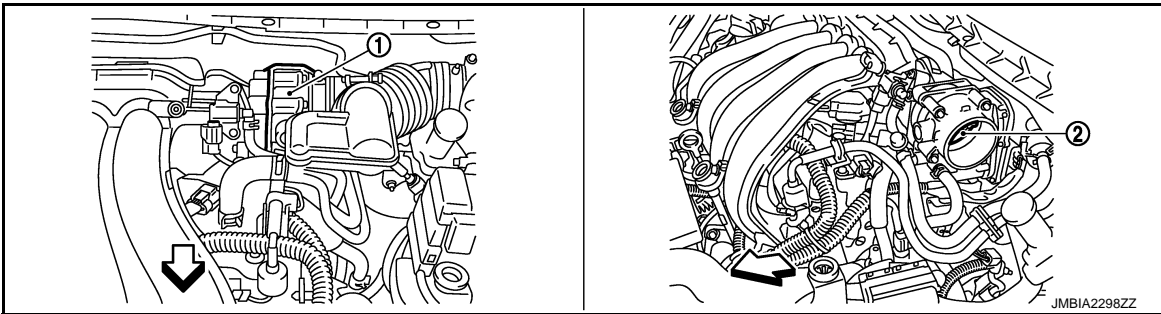

- 1. Electric throttle control actuator (with built-in position sensor, throttle control motor)
- 2. Throttle valve

← Vehicle front

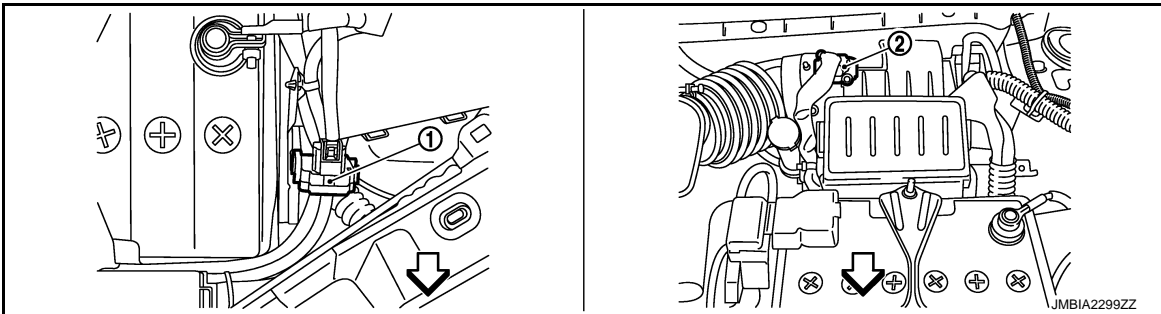

- 1. Battery current sensor
- 2. Mass air flow sensor (with Intake air temperature sensor)

← Vehicle front

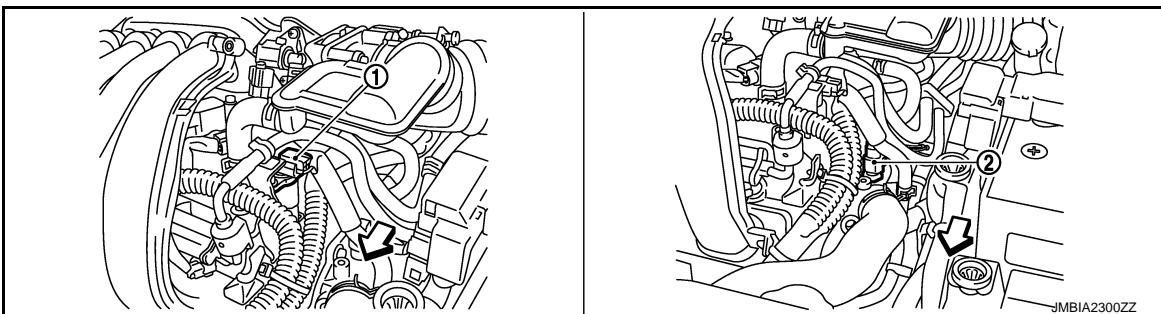

AUTOMATIC SPEED CONTROL DEVICE (ASCD)

[MR18DE]

< SYSTEM DESCRIPTION >

1. Camshaft position sensor (PHASE)
2. Engine coolant temperature sensor

← Vehicle front

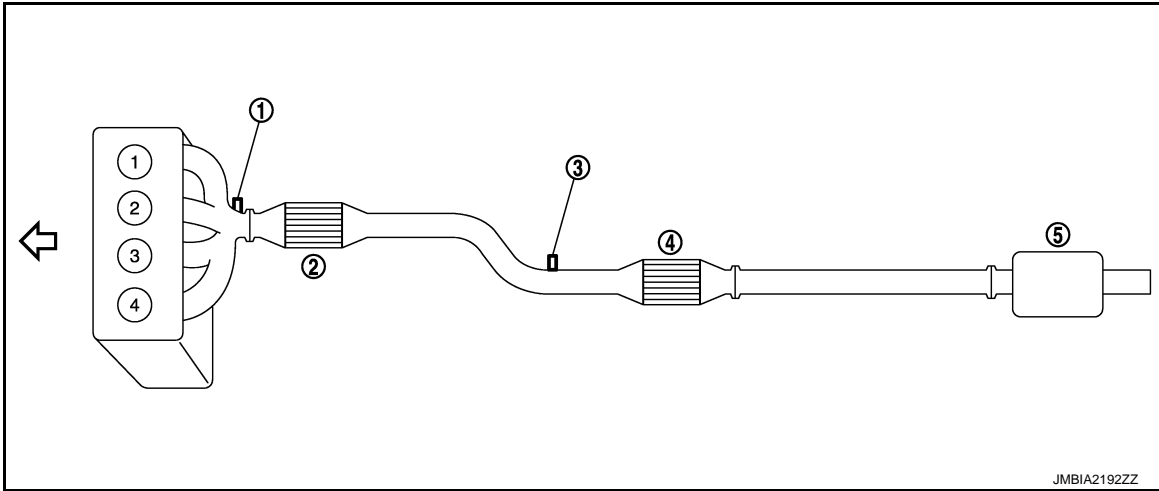

1. Air fuel ratio (A/F) sensor 1
2. Three way catalyst (Manifold)
3. Heated oxygen sensor 2
4. Three way catalyst (under floor)
5. Muffler

← Vehicle front

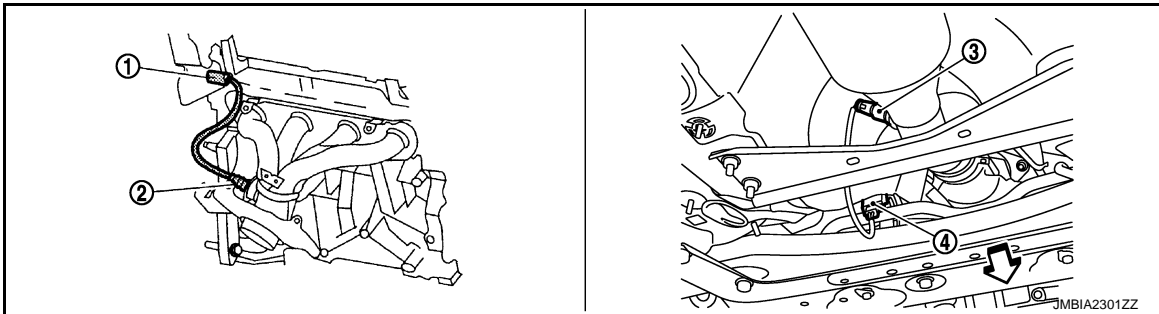

1. Air fuel ratio (A/F) sensor 1 harness
2. Air fuel ratio (A/F) sensor 1
3. Heated oxygen sensor 2
4. Heated oxygen sensor 2 harness connector

← Vehicle front

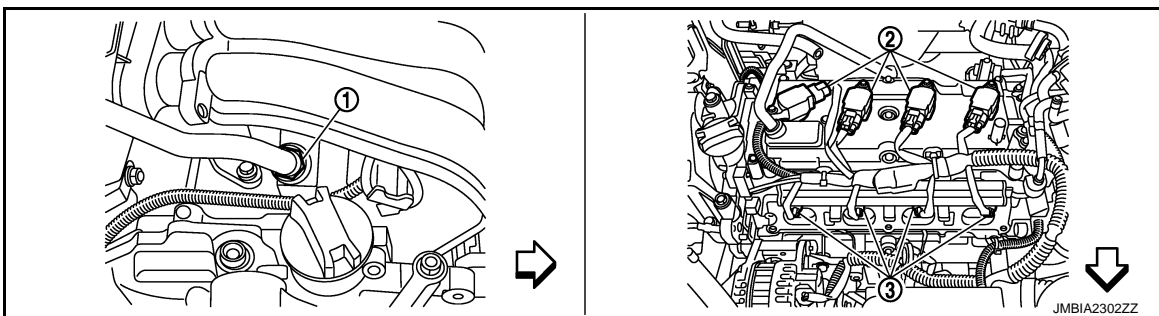

1. PCV valve
2. Ignition coil (with power transistor)
3. Fuel injector

← Vehicle front

A

EC

C

D

E

F

G

H

I

J

K

L

M

N

O

P

AUTOMATIC SPEED CONTROL DEVICE (ASCD)

< SYSTEM DESCRIPTION >

[MR18DE]

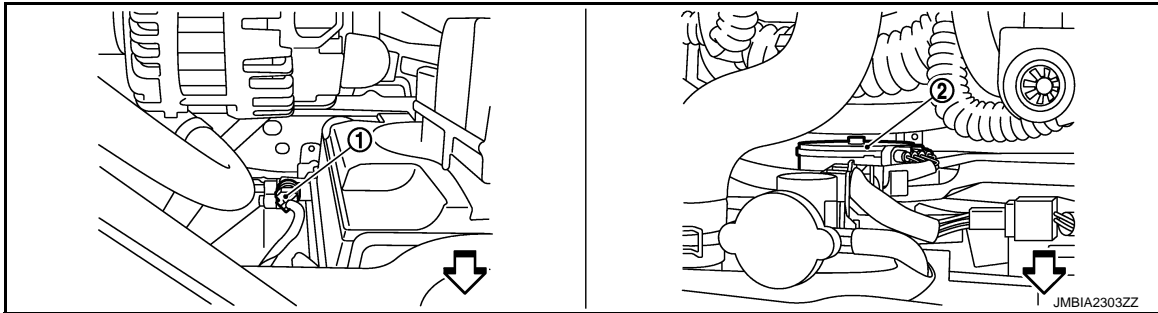

- 1. Refrigerant pressure sensor
- 2. Cooling fan motor

↶ Vehicle front

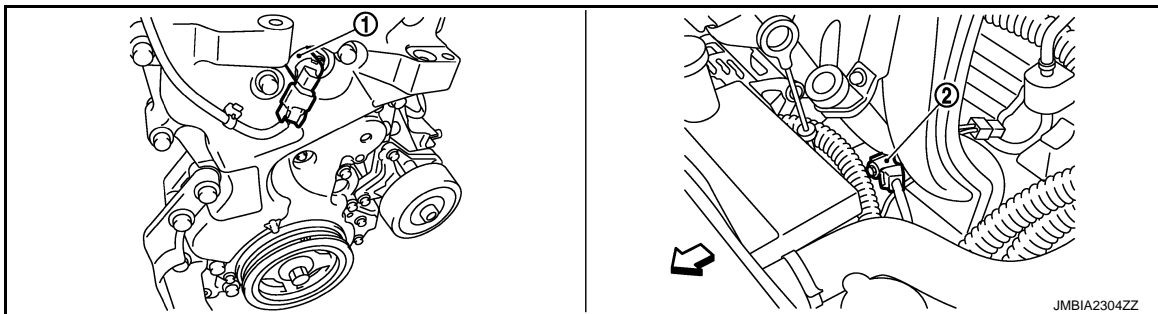

- 1. Intake valve timing control solenoid
- 2. Knock sensor valve

↶ Vehicle front

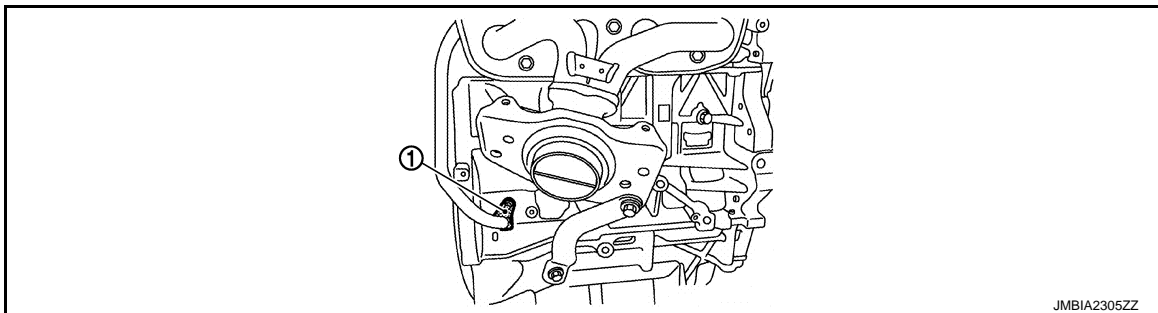

- 1. Crankshaft position sensor (POS)

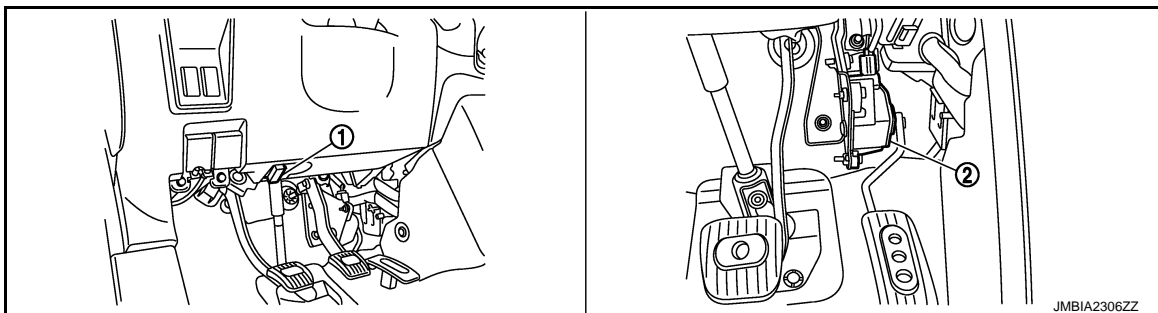

- 1. Data link connector
- 2. Accelerator pedal position sensor

AUTOMATIC SPEED CONTROL DEVICE (ASCD)

< SYSTEM DESCRIPTION >

[MR18DE]

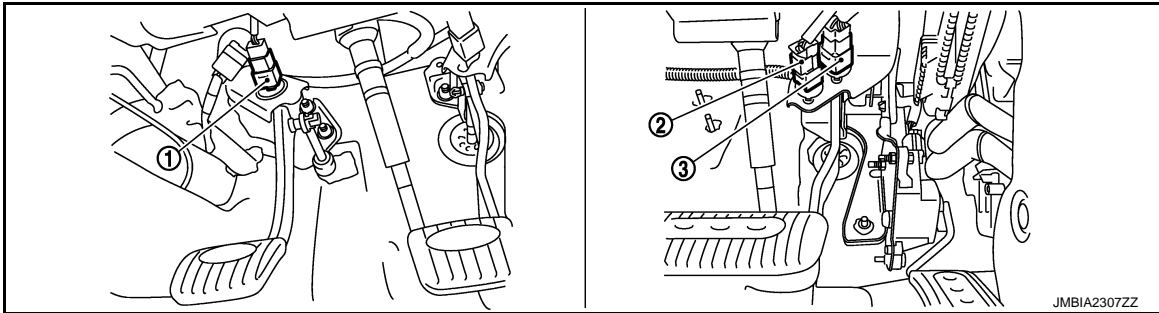

- 1. ASCD clutch switch
- 2. ASCD brake switch
- 3. Stop lamp switch

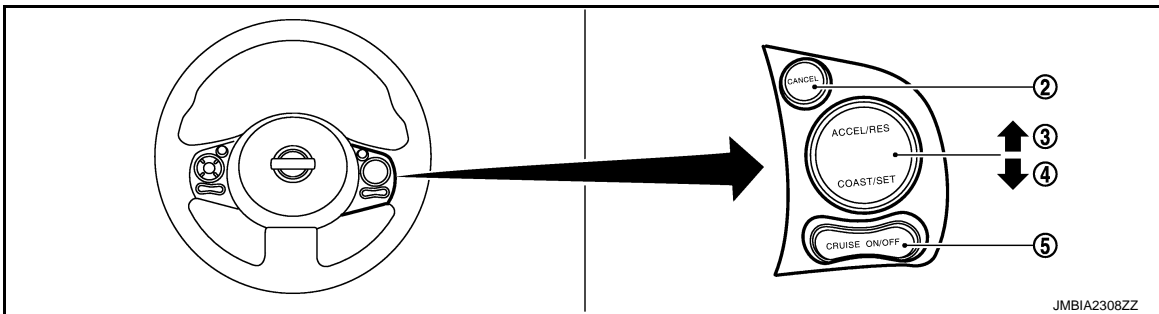

- 1. ASCD steering switch
- 2. CANCEL switch
- 3. RESUME/ACCELERATE switch
- 4. SET/COST switch
- 5. MAIN switch

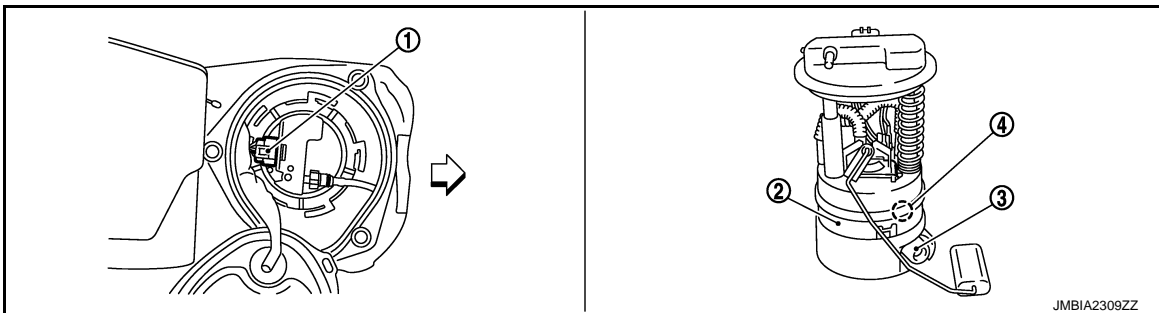

- 1. Fuel level sensor unit and fuel pump
- 2. Fuel level sensor unit and fuel pump
- 3. Fuel pressure regulator harness connector
- 4. Fuel tank temperature sensor

↶ Vehicle front

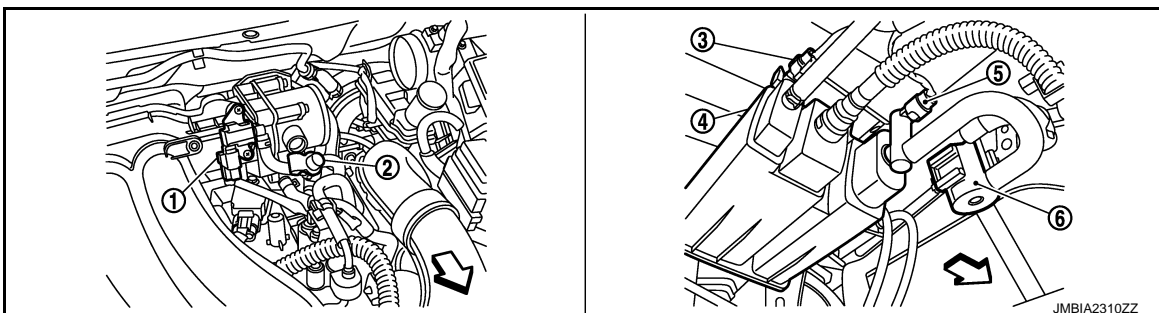

- 1. EVAP canister purge volume control
- 2. EVAP service port solenoid valve
- 3. EVAP control system pressure sensor

A
EC
C
D
E
F
G
H
I
J
K
L
M
N
O
P

AUTOMATIC SPEED CONTROL DEVICE (ASCD)

[MR18DE]

< SYSTEM DESCRIPTION >

4. EVAP canister 5. EVAP canister vent control valve 6. Drain filter
↳ Vehicle front

Component Description

INFOID:000000005040366

Component	Reference
ASCD steering switch	EC-341, "Description"
ASCD brake switch	EC-344, "Description"
ASCD indicator	EC-390, "Description"
Stop lamp switch	EC-344, "Description"
Electric throttle control actuator	EC-366, "Description"

CAN COMMUNICATION

System Description

INFOID:000000004833175

CAN (Controller Area Network) is a serial communication line for real time application. It is an on-vehicle multiplex communication line with high data communication speed and excellent error detection ability. Many electronic control units are equipped onto a vehicle, and each control unit shares information and links with other control units during operation (not independent). In CAN communication, control units are connected with 2 communication lines (CAN H line, CAN L line) allowing a high rate of information transmission with less wiring. Each control unit transmits/receives data but selectively reads required data only.

Refer to [LAN-23. "CAN Communication Signal Chart"](#), about CAN communication for detail..

A

EC

C

D

E

F

G

H

I

J

K

L

M

N

O

P

COOLING FAN CONTROL

< SYSTEM DESCRIPTION >

[MR18DE]

COOLING FAN CONTROL

System Diagram

INFOID:000000004833176

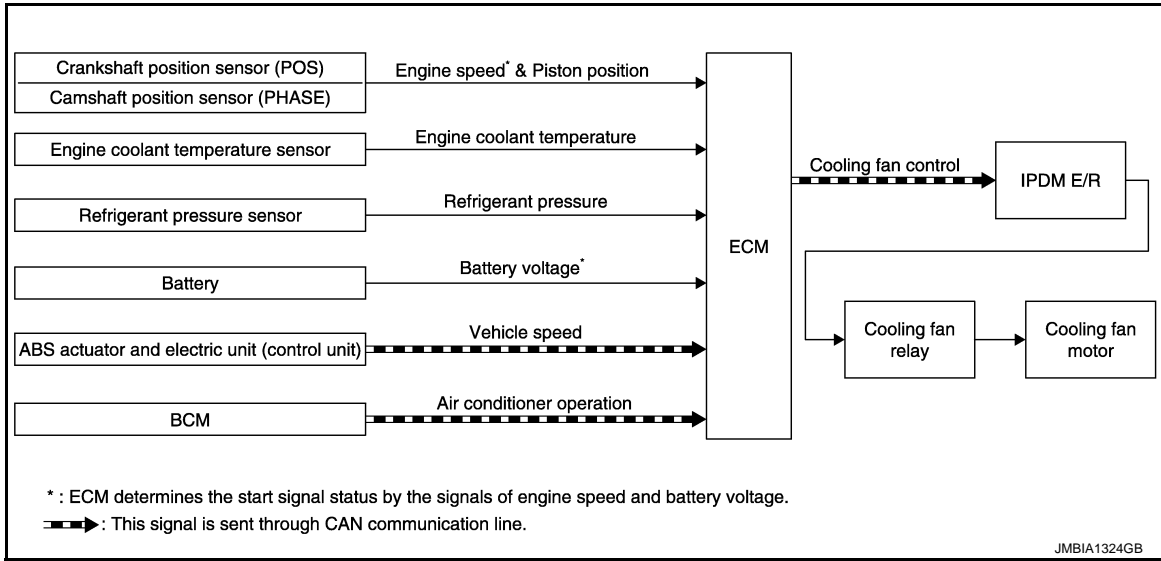

System Description

INFOID:000000004833177

INPUT/OUTPUT SIGNAL CHART

Sensor	Input signal to ECM	ECM function	Actuator
Crankshaft position sensor (POS) Camshaft position sensor (PHASE)	Engine speed* ¹	Cooling fan control	IPDM E/R ↓ Cooling fan relay ↓ Cooling fan motor
Battery	Battery voltage* ¹		
ABS actuator and electric unit (control unit)	Vehicle speed* ²		
Engine coolant temperature sensor	Engine coolant temperature		
BCM	Air conditioner ON signal* ²		
Refrigerant pressure sensor	Refrigerant pressure		

*1: The ECM determines the start signal status by the signals of engine speed and battery voltage.

*2: This signal is sent to ECM via the CAN communication line.

SYSTEM DESCRIPTION

ECM controls cooling fan speed corresponding to vehicle speed, engine coolant temperature, refrigerant pressure, air conditioner ON signal. Then control system has 3-step control [HIGH/LOW/OFF].

COOLING FAN CONTROL

< SYSTEM DESCRIPTION >

[MR18DE]

Cooling Fan Operation

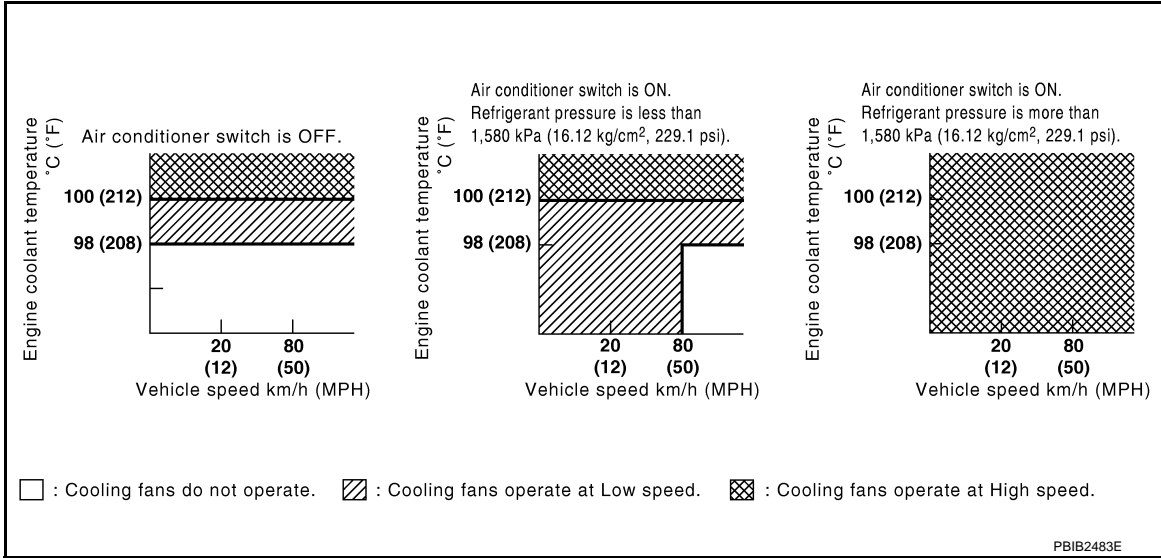

Cooling Fan Relay Operation

The ECM controls cooling fan relays via the CAN communication line.

Cooling fan speed	Cooling fan relay		
	1	2	3
Stop (OFF)	OFF	OFF	OFF
Low (LOW)	ON	OFF	OFF
High (HI)	ON	ON	ON

COOLING FAN CONTROL

< SYSTEM DESCRIPTION >

[MR18DE]

Component Parts Location

INFOID:000000004833178

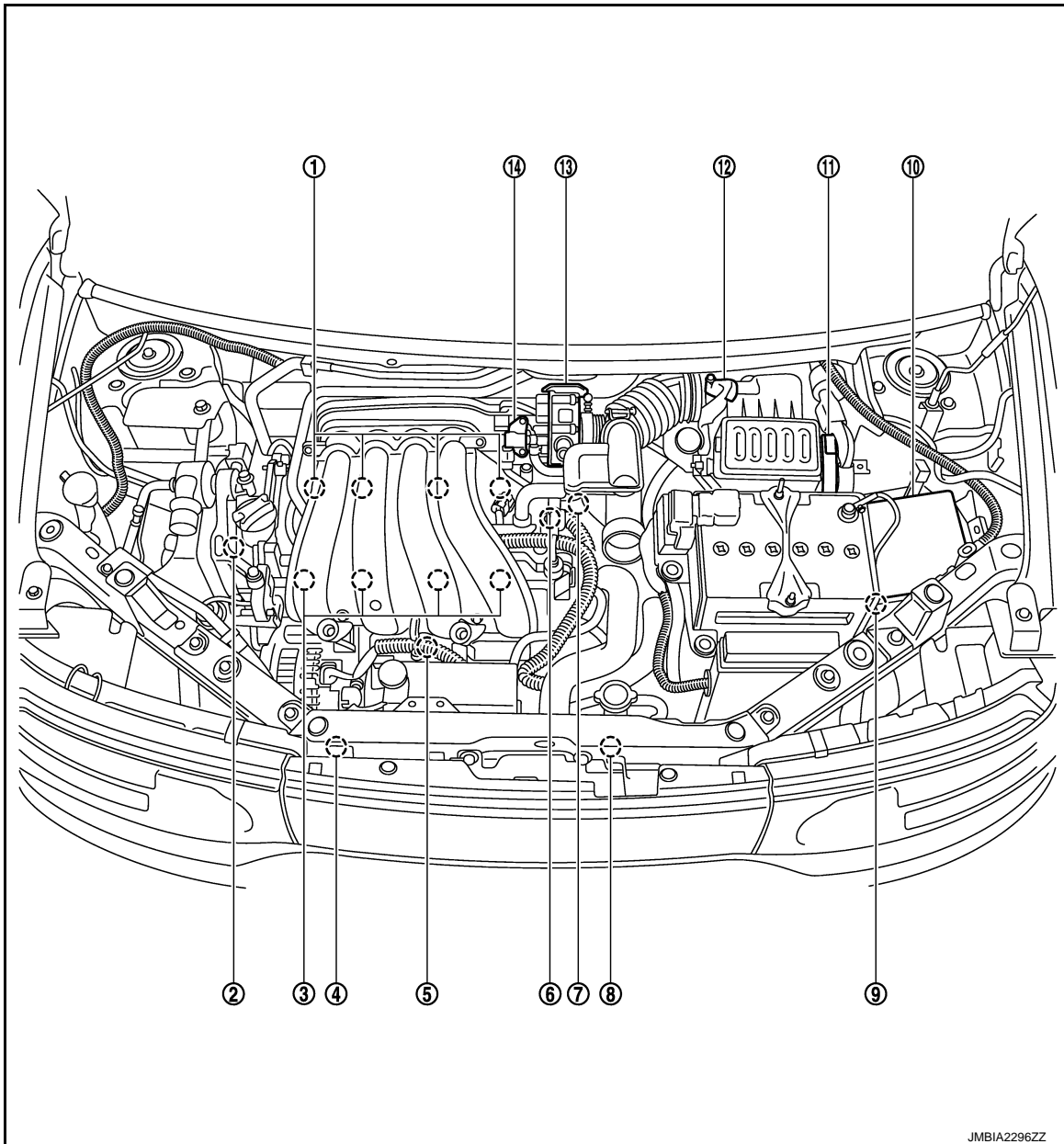

JMBIA2296ZZ

- | | | |
|--|---|---|
| 1. Ignition coil (with power transistor) and spark plug | 2. Intake valve timing control solenoid valve | 3. Fuel injector |
| 4. Refrigerant pressure sensor | 5. Knock sensor | 6. Camshaft position sensor (PHASE) |
| 7. Engine coolant temperature sensor | 8. Cooling fan motor | 9. Battery current sensor |
| 10. IPDM E/R | 11. ECM | 12. Mass air flow sensor (with intake air temperature sensor) |
| 13. Electric throttle control actuator (with built in throttle position sensor and throttle control motor) | 14. EVAP canister purge volume control solenoid valve | |

COOLING FAN CONTROL

< SYSTEM DESCRIPTION >

[MR18DE]

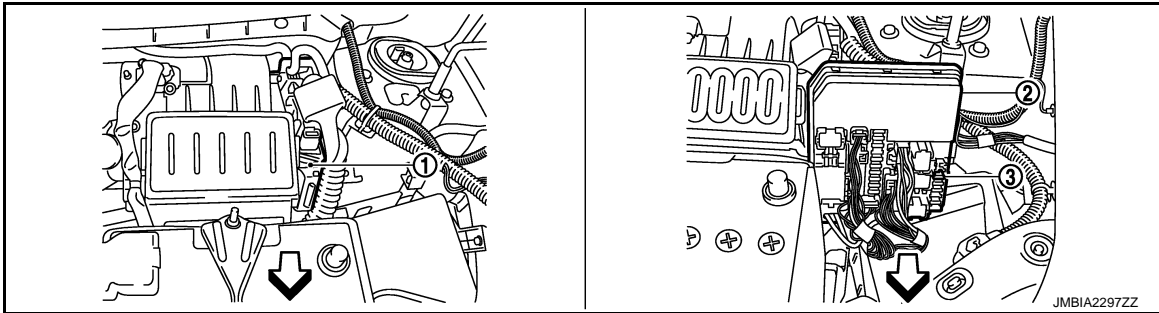

- 1. ECM
- 2. IPDM E/R
- 3. Fuel pump fuse (15 A)

← Vehicle front

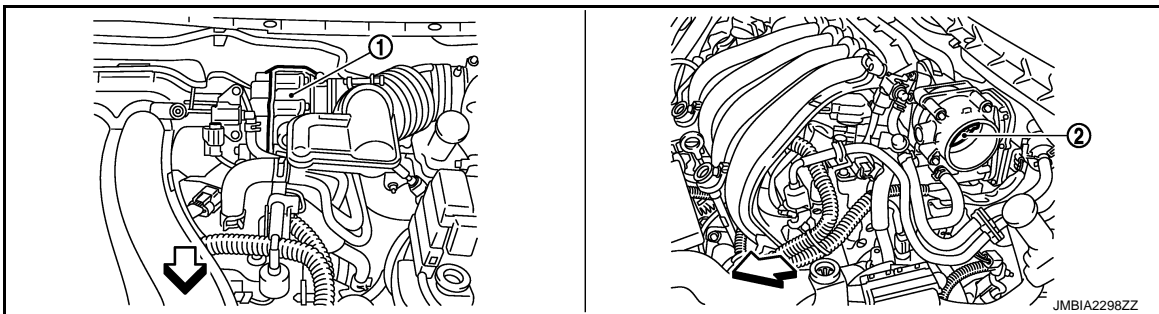

- 1. Electric throttle control actuator (with built-in position sensor, throttle control motor)
- 2. Throttle valve

← Vehicle front

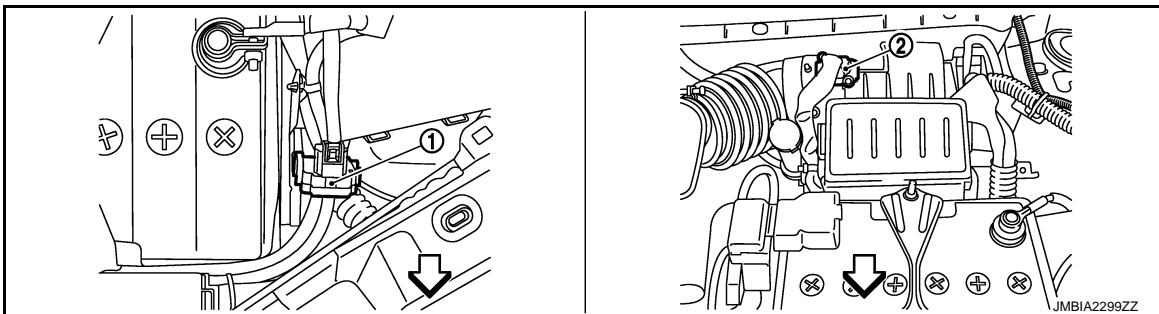

- 1. Battery current sensor
- 2. Mass air flow sensor (with Intake air temperature sensor)

← Vehicle front

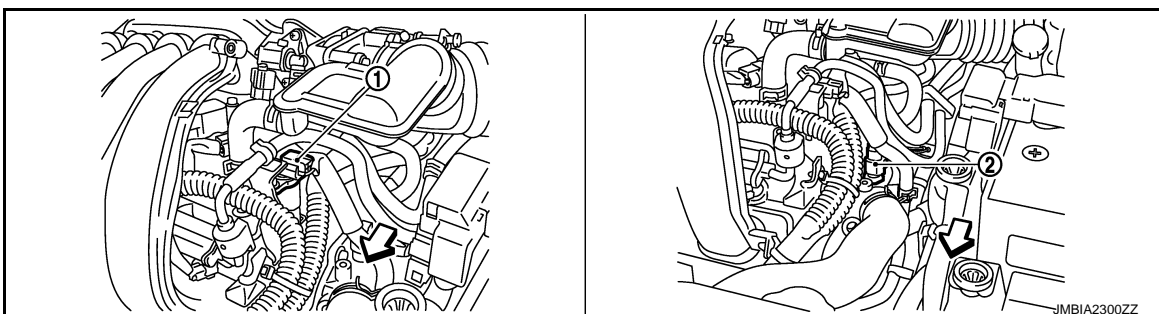

A
EC
C
D
E
F
G
H
I
J
K
L
M
N
O
P

COOLING FAN CONTROL

[MR18DE]

< SYSTEM DESCRIPTION >

1. Camshaft position sensor (PHASE)
2. Engine coolant temperature sensor

↶ Vehicle front

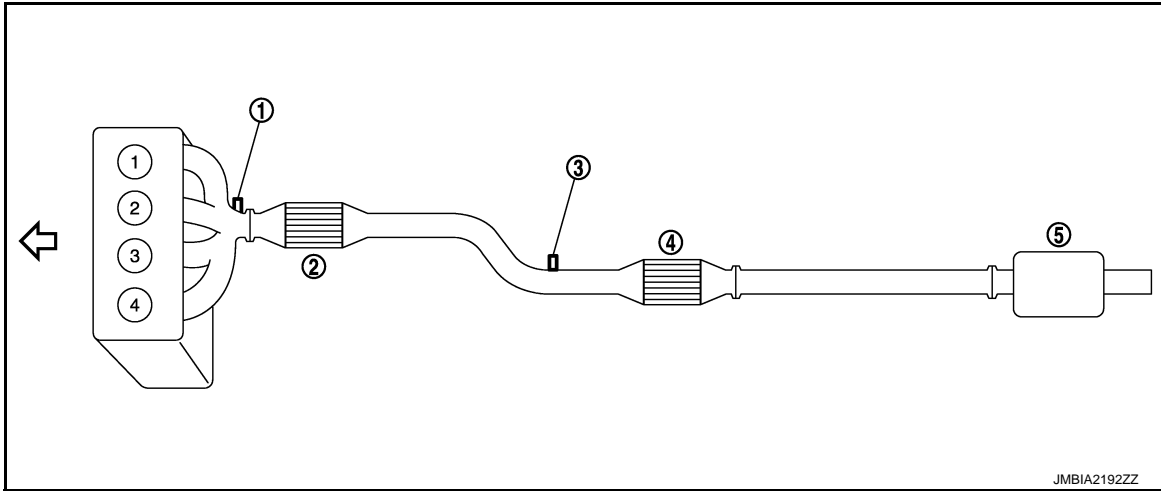

1. Air fuel ratio (A/F) sensor 1
2. Three way catalyst (Manifold)
3. Heated oxygen sensor 2
4. Three way catalyst (under floor)
5. Muffler

↶ Vehicle front

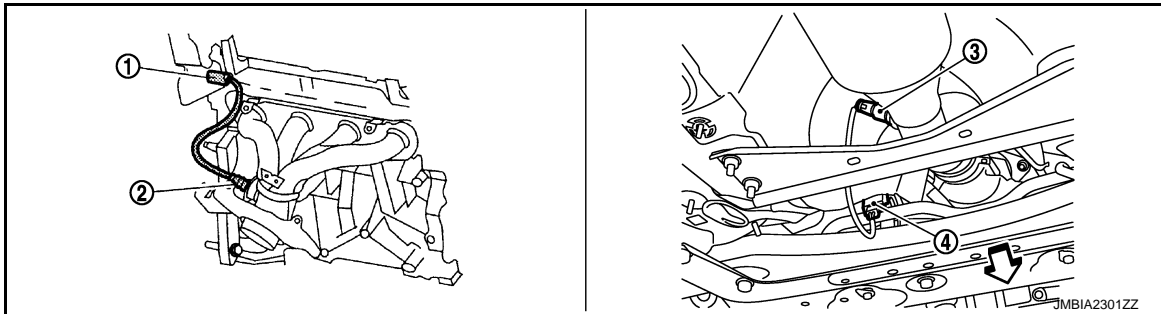

1. Air fuel ratio (A/F) sensor 1 harness
2. Air fuel ratio (A/F) sensor 1 connector
3. Heated oxygen sensor 2
4. Heated oxygen sensor 2 harness connector

↶ Vehicle front

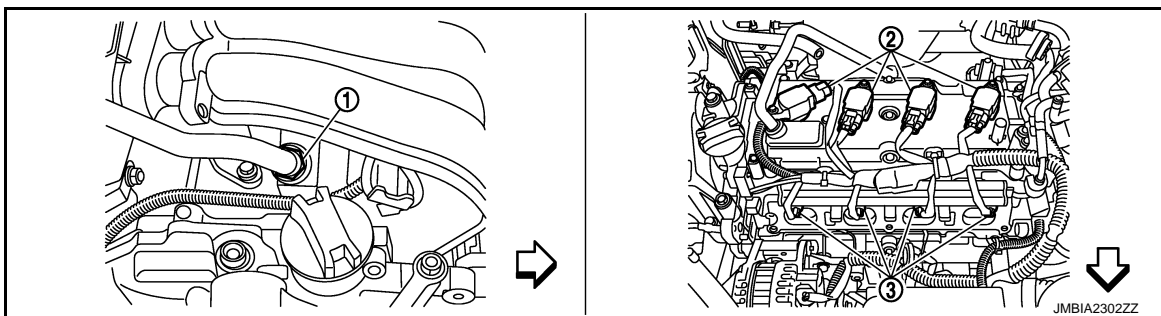

1. PCV valve
2. Ignition coil (with power transistor)
3. Fuel injector

↶ Vehicle front

COOLING FAN CONTROL

< SYSTEM DESCRIPTION >

[MR18DE]

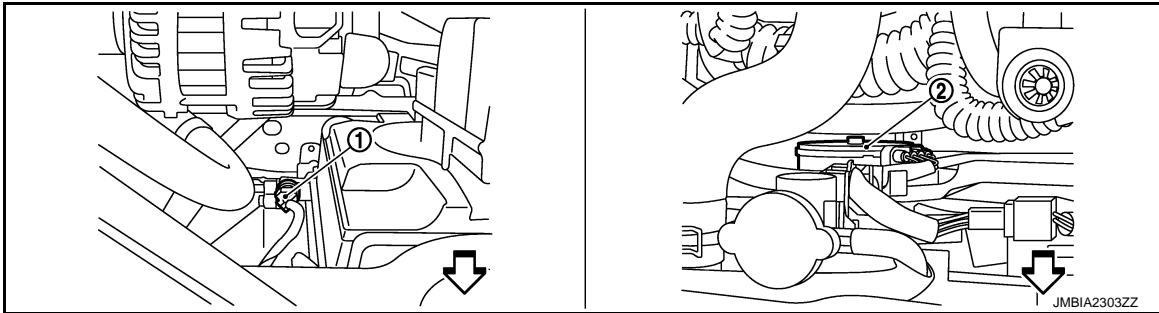

- 1. Refrigerant pressure sensor
- 2. Cooling fan motor

← Vehicle front

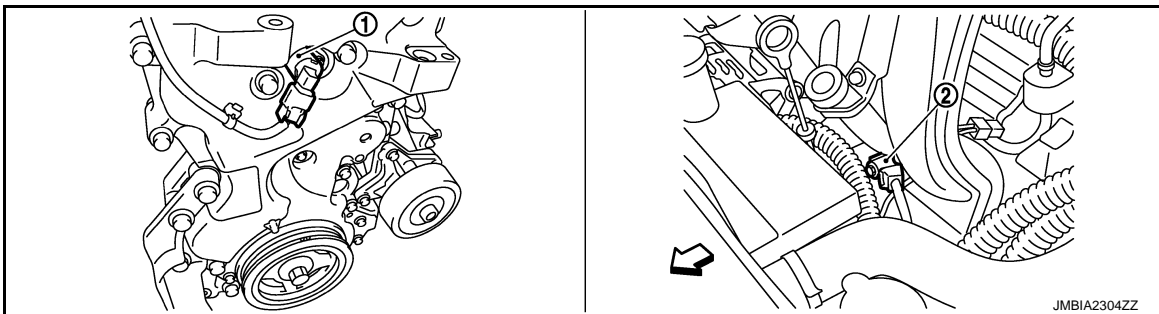

- 1. Intake valve timing control solenoid
- 2. Knock sensor valve

← Vehicle front

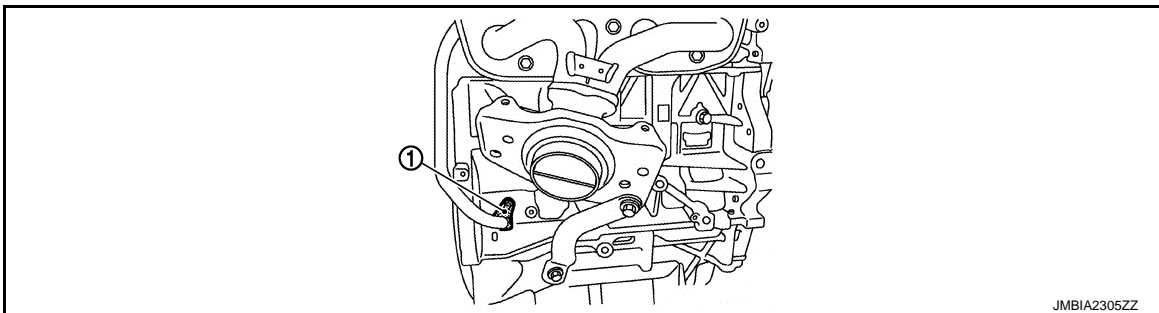

- 1. Crankshaft position sensor (POS)

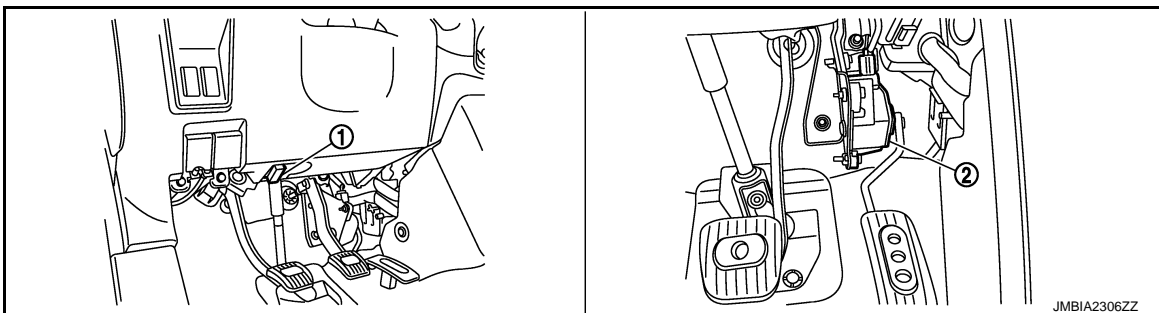

- 1. Data link connector
- 2. Accelerator pedal position sensor

A
EC
C
D
E
F
G
H
I
J
K
L
M
N
O
P

COOLING FAN CONTROL

< SYSTEM DESCRIPTION >

[MR18DE]

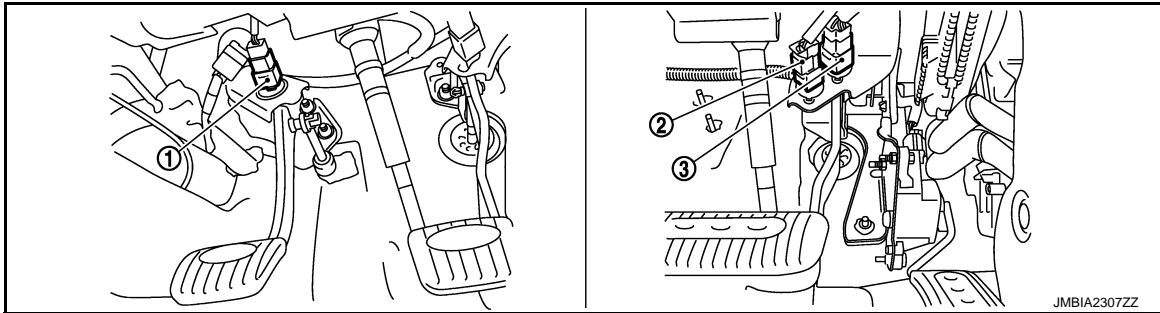

- 1. ASCD clutch switch
- 2. ASCD brake switch
- 3. Stop lamp switch

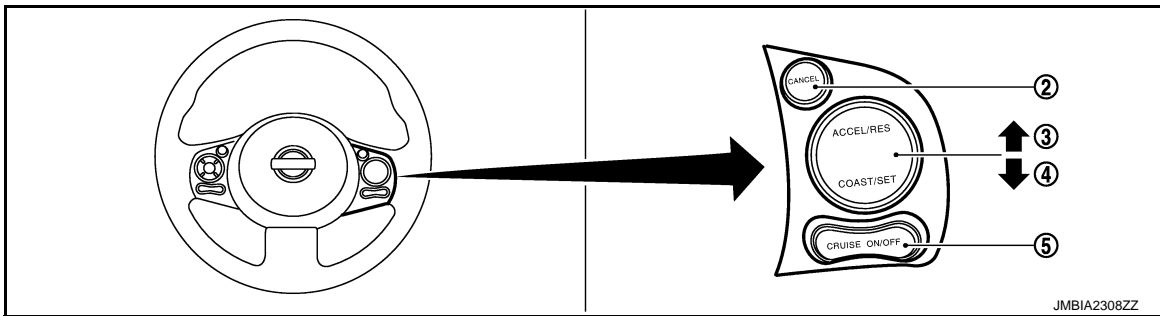

- 1. ASCD steering switch
- 2. CANCEL switch
- 3. RESUME/ACCELERATE switch
- 4. SET/COAST switch
- 5. MAIN switch

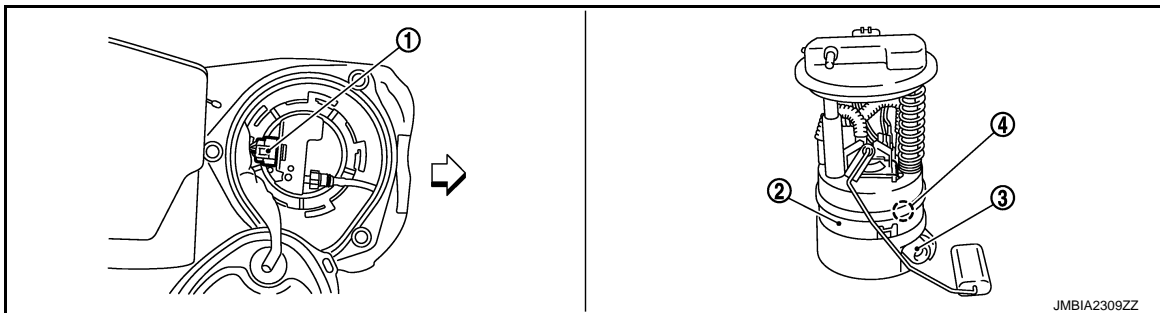

- 1. Fuel level sensor unit and fuel pump harness connector
 - 2. Fuel level sensor unit and fuel pump
 - 3. Fuel pressure regulator
 - 4. Fuel tank temperature sensor
- ↙ Vehicle front

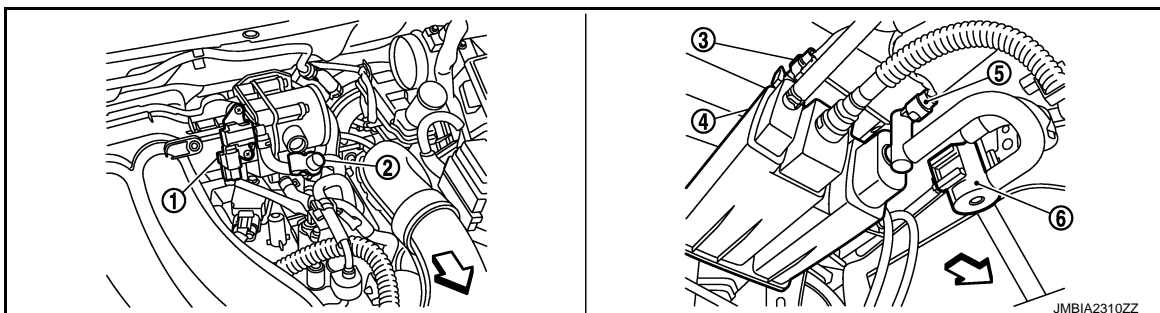

- 1. EVAP canister purge volume control solenoid valve
- 2. EVAP service port
- 3. EVAP control system pressure sensor

COOLING FAN CONTROL

< SYSTEM DESCRIPTION >

[MR18DE]

- 4. EVAP canister
 - 5. EVAP canister vent control valve
 - 6. Drain filter
- ↶ Vehicle front

A

Component Description

INFOID:000000004833179

EC

Component	Reference
Camshaft position sensor (PHASE)	EC-229. "Description"
Crankshaft position sensor (POS)	EC-225. "Description"
Cooling fan motor	EC-60. "System Description"
Engine coolant temperature sensor	EC-152. "Description"
Refrigerant pressure sensor	EC-414. "Description"

C

D

E

F

G

H

I

J

K

L

M

N

O

P

EVAPORATIVE EMISSION SYSTEM

[MR18DE]

< SYSTEM DESCRIPTION >

EVAPORATIVE EMISSION SYSTEM

System Diagram

INFOID:000000004833180

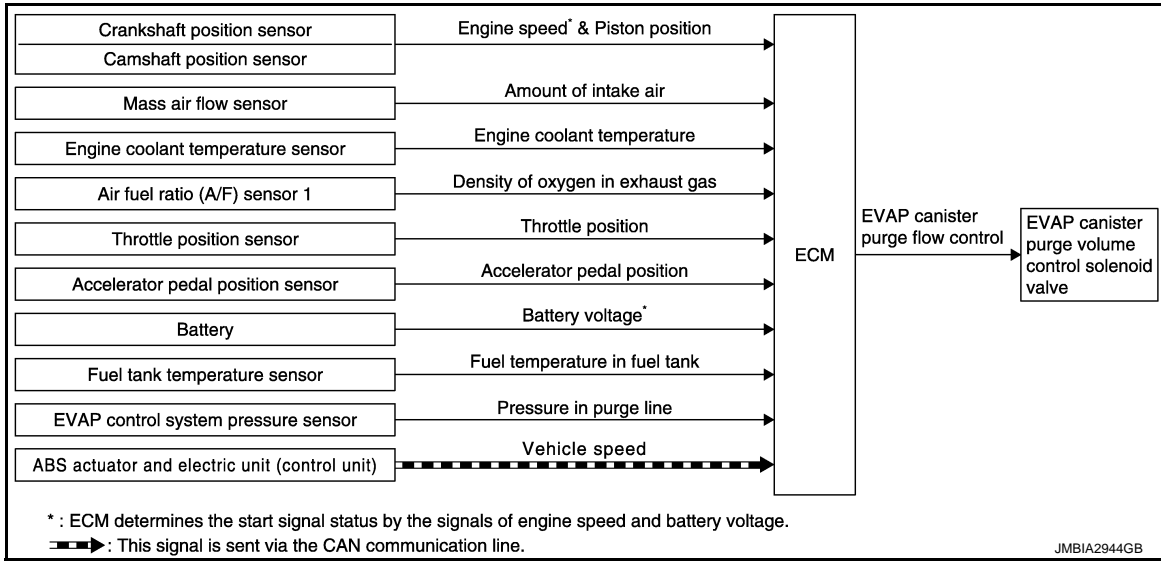

System Description

INFOID:000000004833181

INPUT/OUTPUT SIGNAL CHART

Sensor	Input signal to ECM	ECM function	Actuator
Crankshaft position sensor (POS) Camshaft position sensor (PHASE)	Engine speed*1	EVAP canister purge flow control	EVAP canister purge vol- ume control solenoid valve
Mass air flow sensor	Amount of intake air		
Engine coolant temperature sensor	Engine coolant temperature		
Battery	Battery voltage*1		
Throttle position sensor	Throttle position		
Accelerator pedal position sensor	Accelerator pedal position		
Air fuel ratio (A/F) sensor 1	Density of oxygen in exhaust gas (Mixture ratio feedback signal)		
Fuel tank temperature sensor	Fuel temperature in fuel tank		
EVAP control system pressure sensor	Pressure in purge line		
ABS actuator and electric unit (control unit)	Vehicle speed*2		

*1: ECM determines the start signal status by the signals of engine speed and battery voltage.

*2: This signal is sent to the ECM via the CAN communication line.

EVAPORATIVE EMISSION SYSTEM

[MR18DE]

< SYSTEM DESCRIPTION >

SYSTEM DESCRIPTION

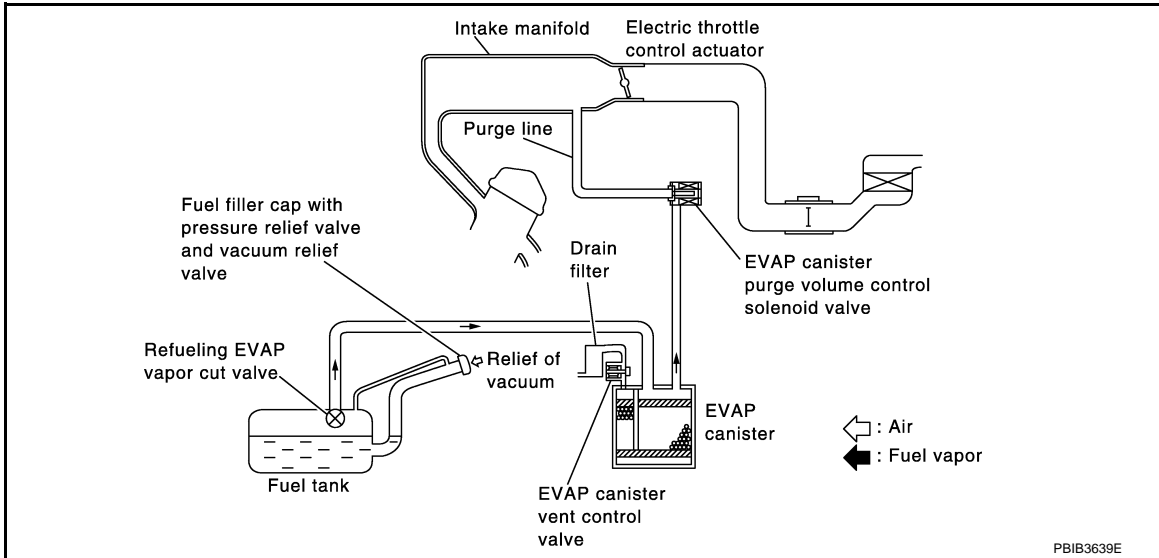

The evaporative emission system is used to reduce hydrocarbons emitted into the atmosphere from the fuel system. This reduction of hydrocarbons is accomplished by activated charcoals in the EVAP canister. The fuel vapor in the sealed fuel tank is led into the EVAP canister which contains activated carbon and the vapor is stored there when the engine is not operating or when refueling to the fuel tank.

The vapor in the EVAP canister is purged by the air through the purge line to the intake manifold when the engine is operating. EVAP canister purge volume control solenoid valve is controlled by ECM. When the engine operates, the flow rate of vapor controlled by EVAP canister purge volume control solenoid valve is proportionally regulated as the air flow increases.

EVAP canister purge volume control solenoid valve also shuts off the vapor purge line during decelerating.

EVAPORATIVE EMISSION LINE DRAWING

EVAPORATIVE EMISSION SYSTEM

< SYSTEM DESCRIPTION >

[MR18DE]

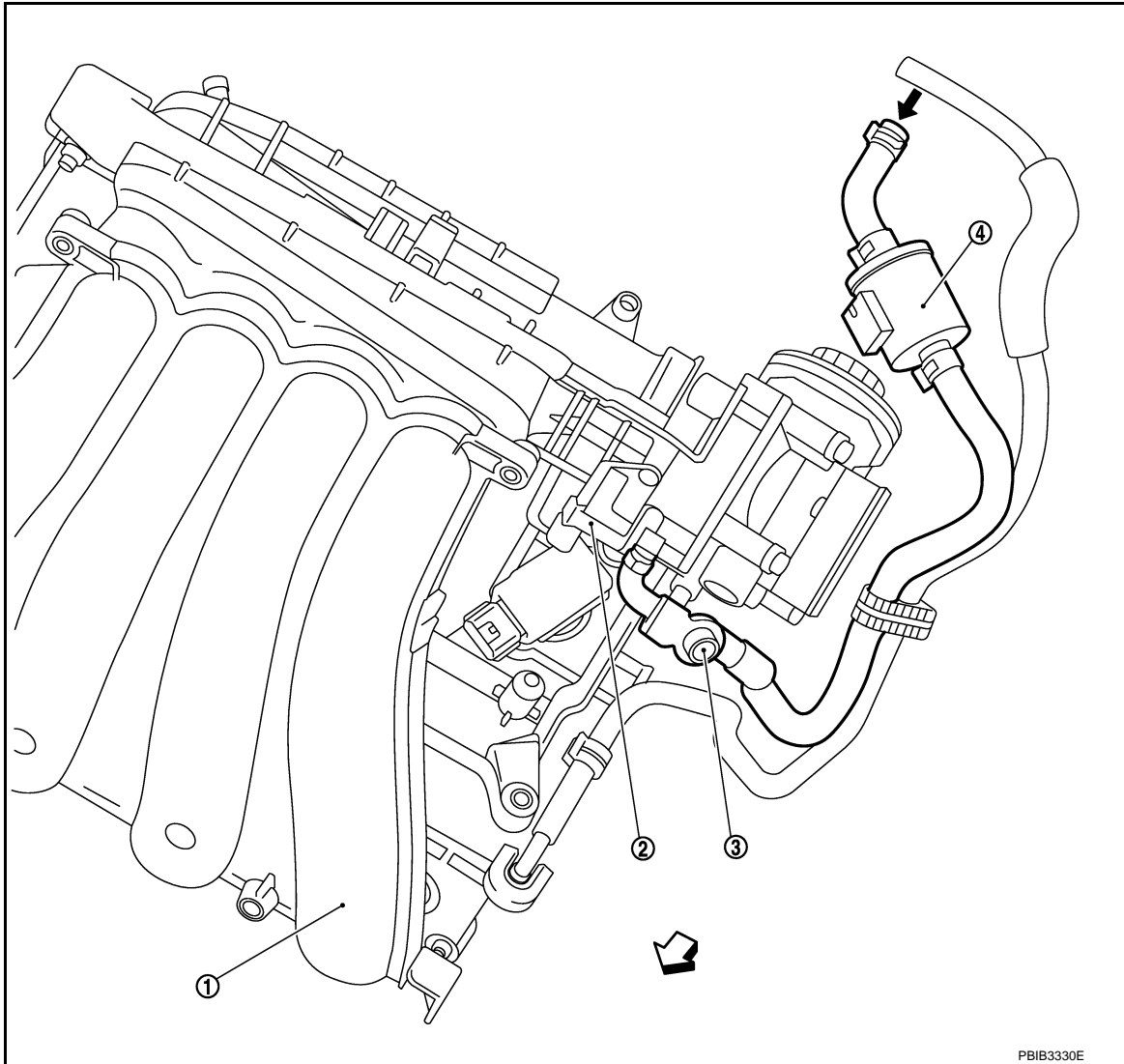

1. Intake manifold collector

2. EVAP canister purge volume control

3. EVAP service port solenoid valve

4. EVAP purge resonator

↔ Vehicle front

← From next figure

EVAPORATIVE EMISSION SYSTEM

< SYSTEM DESCRIPTION >

[MR18DE]

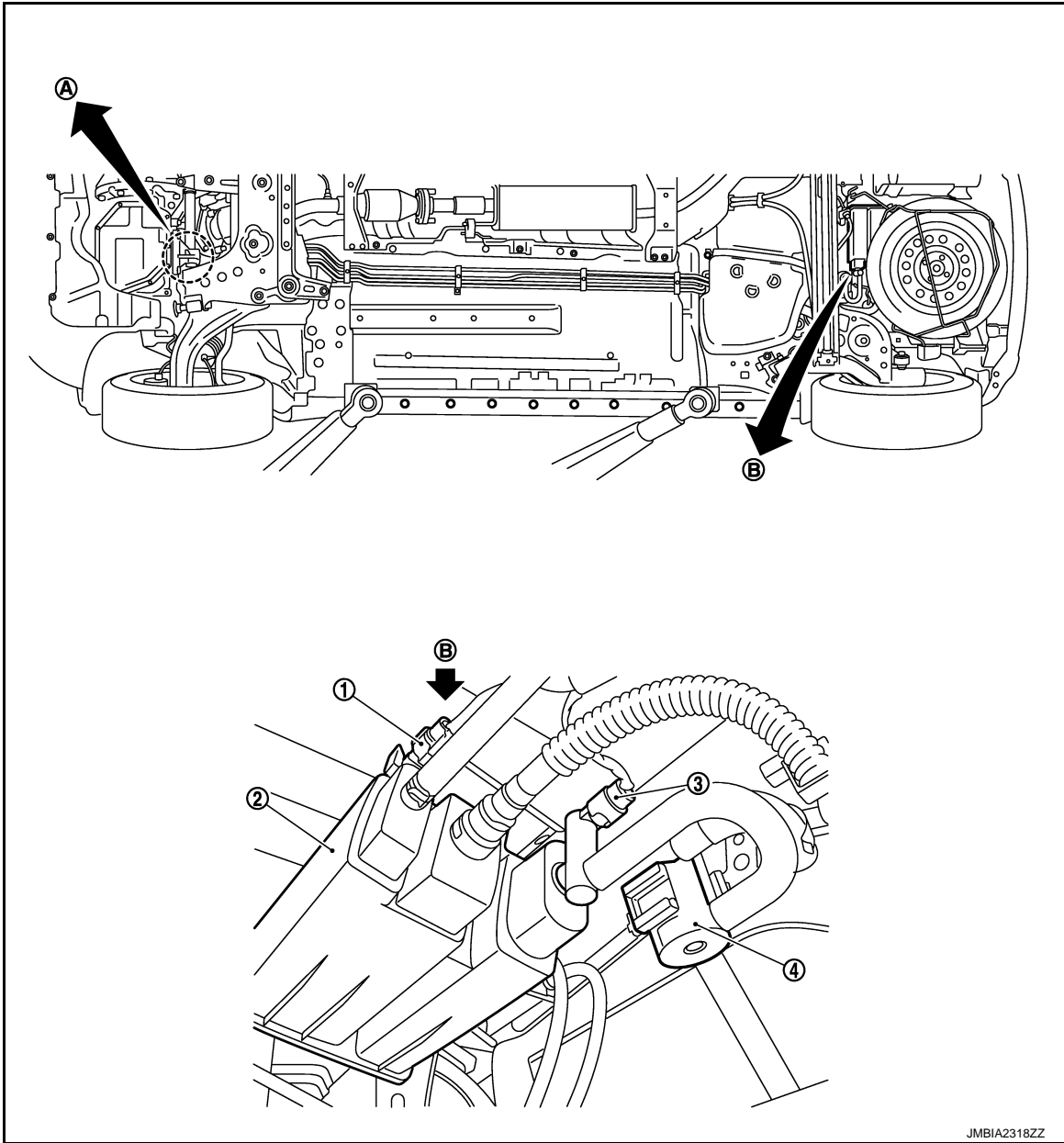

- 1. EVAP control system pressure sensor
- 2. EVAP canister
- 3. EVAP canister vent control valve
- 4. Drain filter
- A. To previous figure

NOTE:

Do not use soapy water or any type of solvent while installing vacuum hose or purge hoses.

A
EC
C
D
E
F
G
H
I
J
K
L
M
N
O
P

EVAPORATIVE EMISSION SYSTEM

< SYSTEM DESCRIPTION >

[MR18DE]

Component Parts Location

INFOID:000000004833182

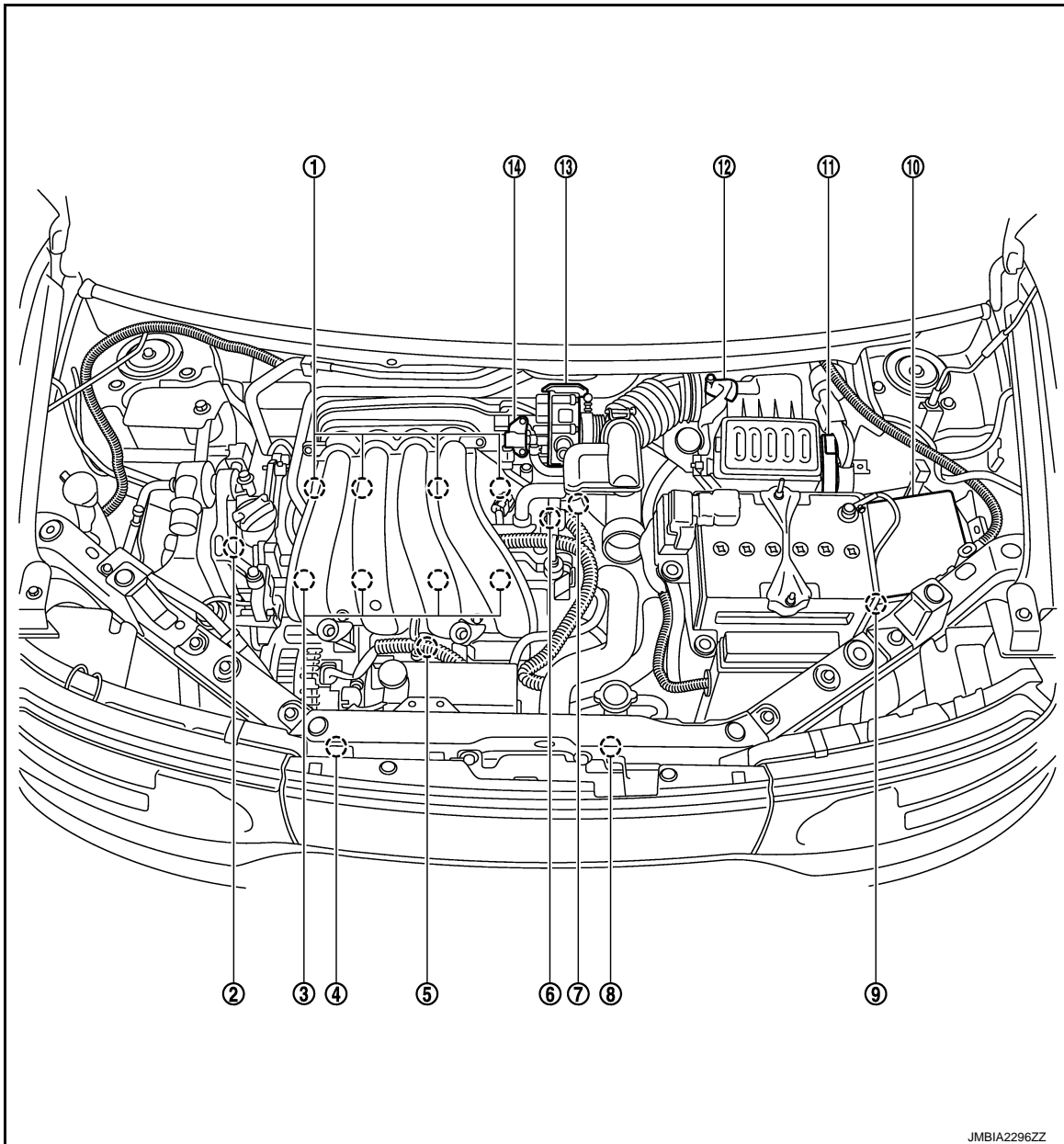

JMBIA2296ZZ

- | | | |
|--|---|---|
| 1. Ignition coil (with power transistor) and spark plug | 2. Intake valve timing control solenoid valve | 3. Fuel injector |
| 4. Refrigerant pressure sensor | 5. Knock sensor | 6. Camshaft position sensor (PHASE) |
| 7. Engine coolant temperature sensor | 8. Cooling fan motor | 9. Battery current sensor |
| 10. IPDM E/R | 11. ECM | 12. Mass air flow sensor (with intake air temperature sensor) |
| 13. Electric throttle control actuator (with built in throttle position sensor and throttle control motor) | 14. EVAP canister purge volume control solenoid valve | |

EVAPORATIVE EMISSION SYSTEM

< SYSTEM DESCRIPTION >

[MR18DE]

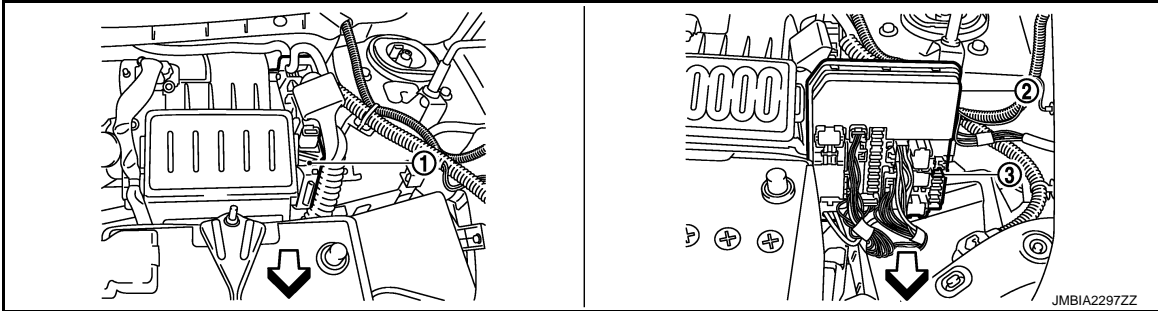

- 1. ECM
- 2. IPDM E/R
- 3. Fuel pump fuse (15 A)

← Vehicle front

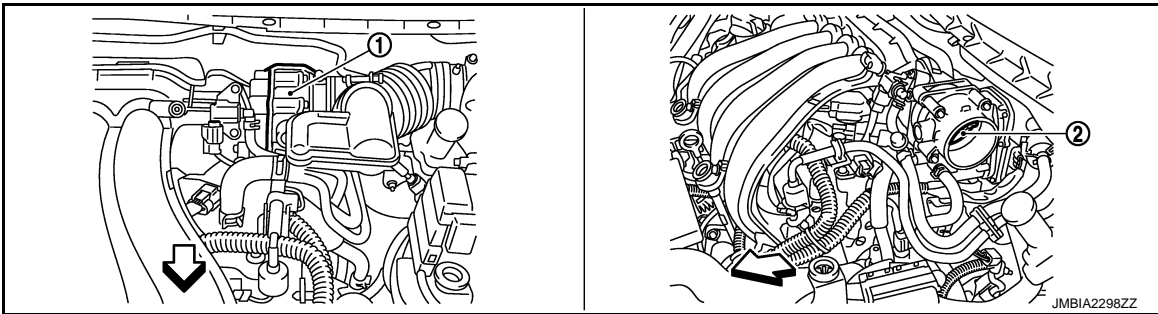

- 1. Electric throttle control actuator (with built-in position sensor, throttle control motor)
- 2. Throttle valve

← Vehicle front

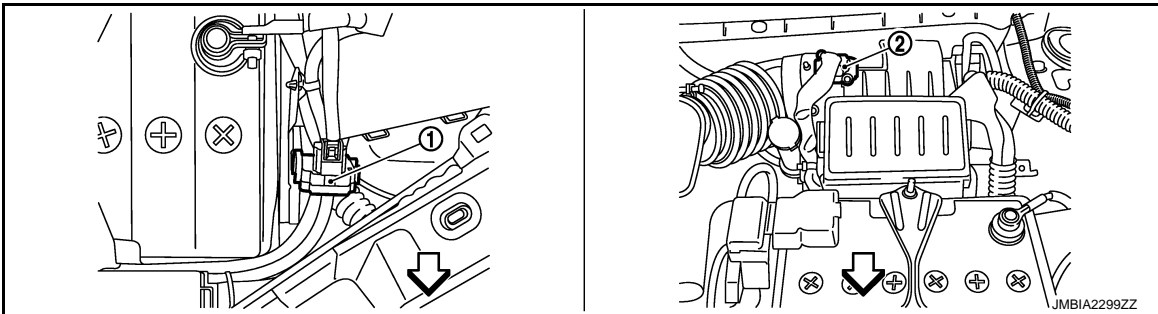

- 1. Battery current sensor
- 2. Mass air flow sensor (with Intake air temperature sensor)

← Vehicle front

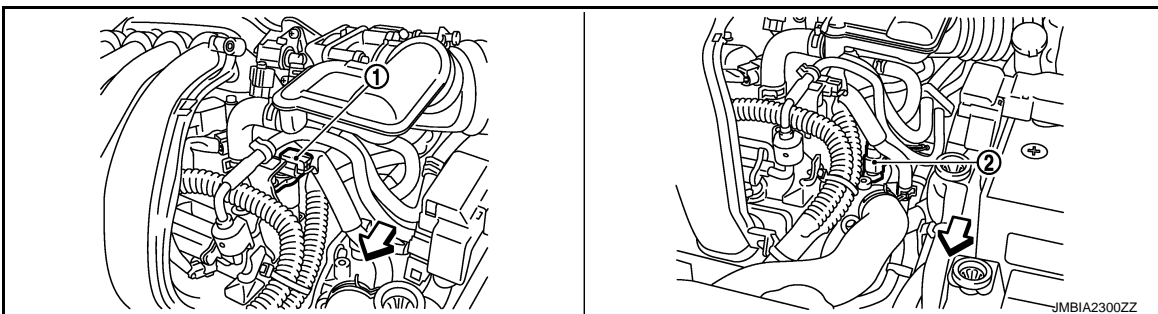

A
EC
C
D
E
F
G
H
I
J
K
L
M
N
O
P

EVAPORATIVE EMISSION SYSTEM

[MR18DE]

< SYSTEM DESCRIPTION >

1. Camshaft position sensor (PHASE)
2. Engine coolant temperature sensor

↶ Vehicle front

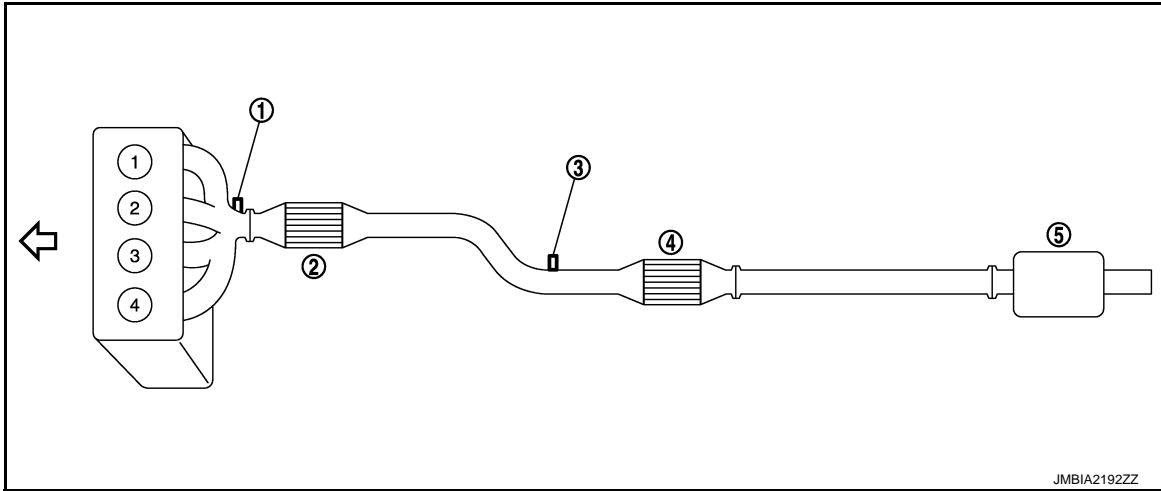

1. Air fuel ratio (A/F) sensor 1
2. Three way catalyst (Manifold)
3. Heated oxygen sensor 2
4. Three way catalyst (under floor)
5. Muffer

↶ Vehicle front

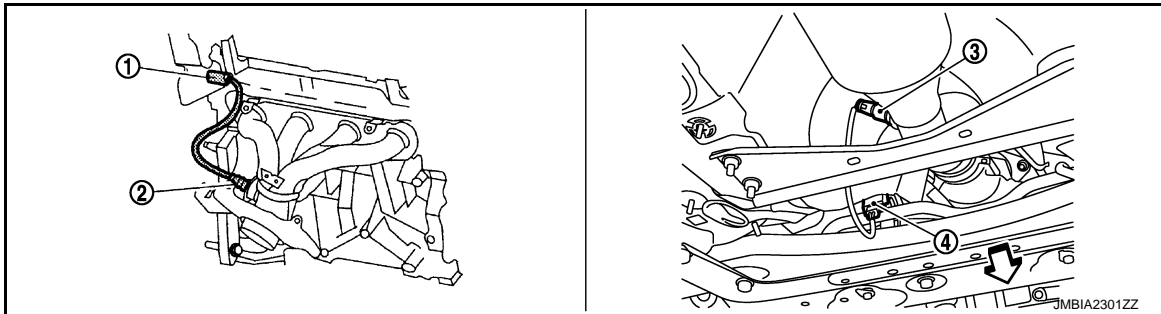

1. Air fuel ratio (A/F) sensor 1 harness
2. Air fuel ratio (A/F) sensor 1 connector
3. Heated oxygen sensor 2
4. Heated oxygen sensor 2 harness connector

↶ Vehicle front

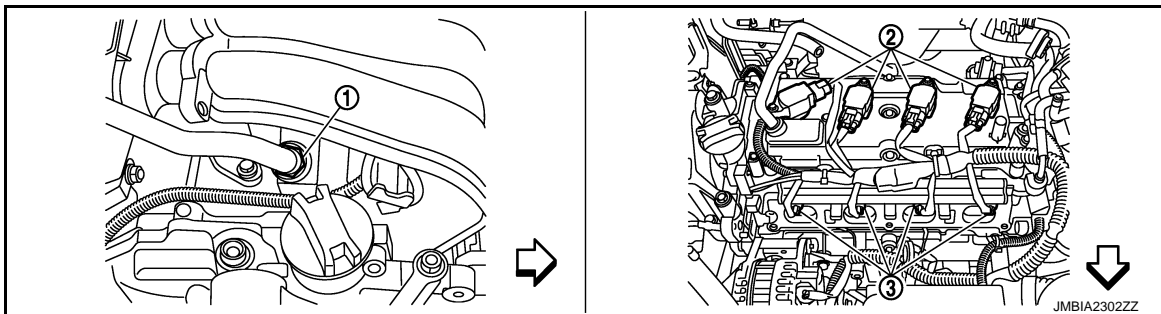

1. PCV valve
2. Ignition coil (with power transistor)
3. Fuel injector

↶ Vehicle front

EVAPORATIVE EMISSION SYSTEM

< SYSTEM DESCRIPTION >

[MR18DE]

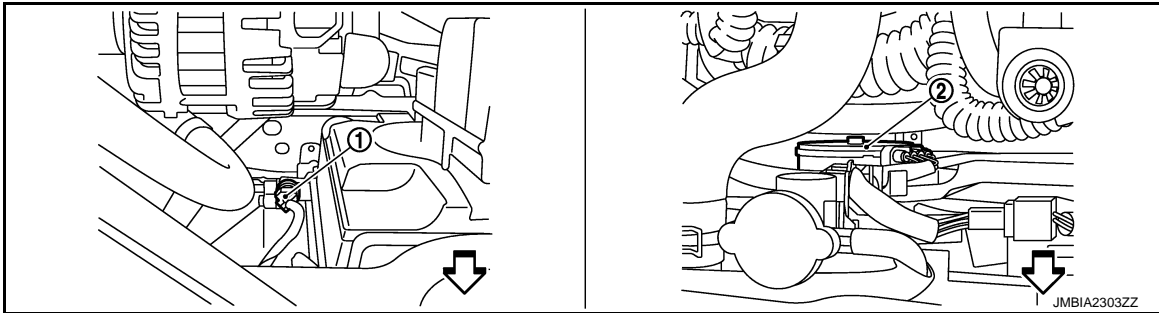

- 1. Refrigerant pressure sensor
- 2. Cooling fan motor

↶ Vehicle front

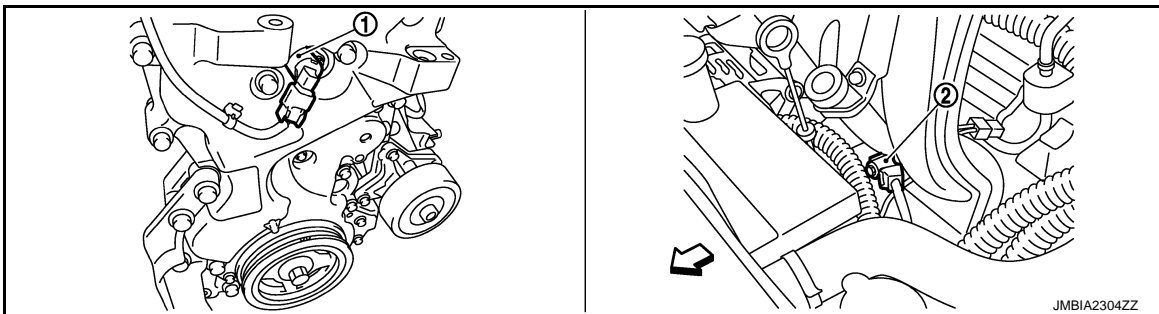

- 1. Intake valve timing control solenoid
- 2. Knock sensor valve

↶ Vehicle front

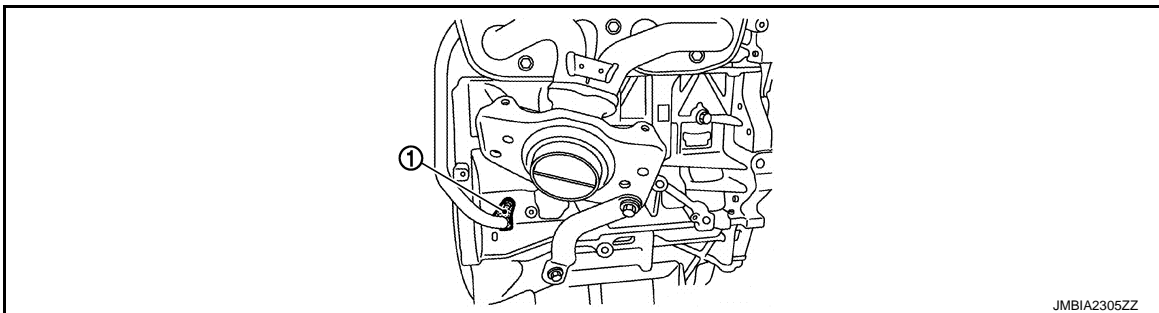

- 1. Crankshaft position sensor (POS)

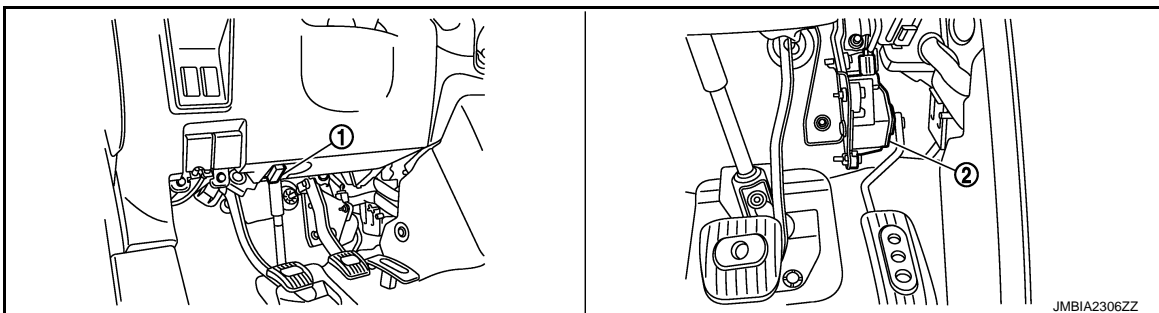

- 1. Data link connector
- 2. Accelerator pedal position sensor

A
EC
C
D
E
F
G
H
I
J
K
L
M
N
O
P

EVAPORATIVE EMISSION SYSTEM

< SYSTEM DESCRIPTION >

[MR18DE]

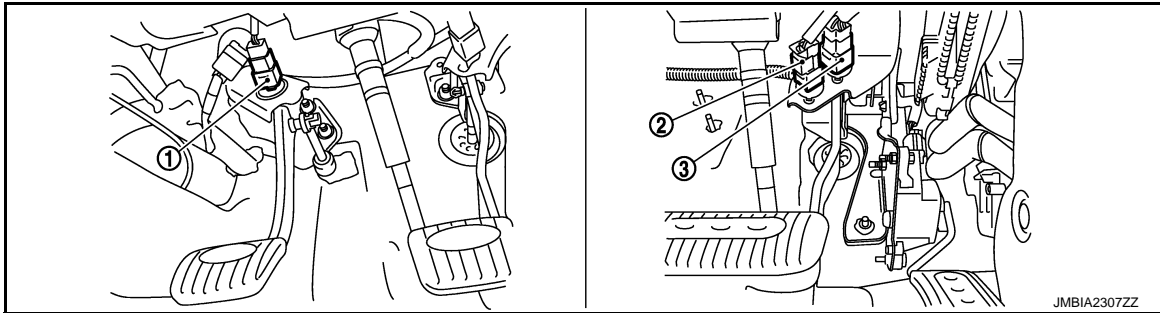

- 1. ASCD clutch switch
- 2. ASCD brake switch
- 3. Stop lamp switch

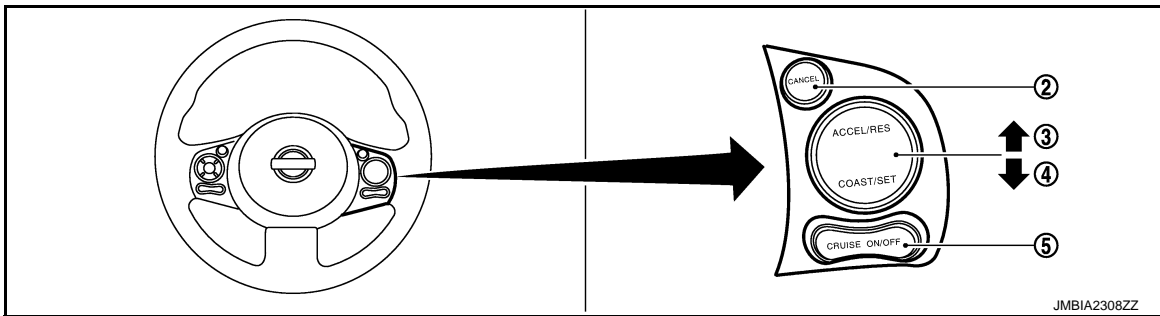

- 1. ASCD steering switch
- 2. CANCEL switch
- 3. RESUME/ACCELERATE switch
- 4. SET/COST switch
- 5. MAIN switch

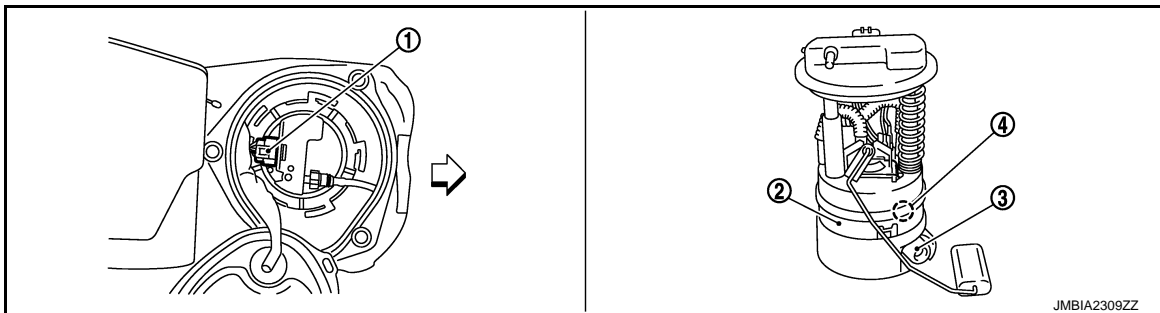

- 1. Fuel level sensor unit and fuel pump harness connector
 - 2. Fuel level sensor unit and fuel pump
 - 3. Fuel pressure regulator
 - 4. Fuel tank temperature sensor
- ↙ Vehicle front

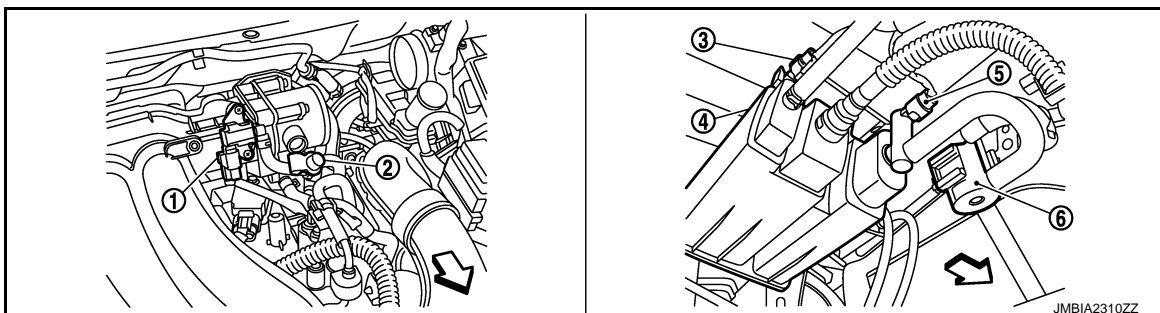

- 1. EVAP canister purge volume control solenoid valve
- 2. EVAP service port
- 3. EVAP control system pressure sensor

EVAPORATIVE EMISSION SYSTEM

[MR18DE]

< SYSTEM DESCRIPTION >

- 4. EVAP canister
 - 5. EVAP canister vent control valve
 - 6. Drain filter
- ↶ Vehicle front

A

Component Description

INFOID:000000004833183

EC

Component	Reference
A/F sensor 1	EC-165. "Description"
Accelerator pedal position sensor	EC-368. "Description"
Camshaft position sensor (PHASE)	EC-229. "Description"
Crankshaft position sensor (POS)	EC-225. "Description"
Engine coolant temperature sensor	EC-152. "Description"
EVAP canister purge volume control solenoid valve	EC-251. "Description"
EVAP control system pressure sensor	EC-267. "Description"
Fuel tank temperature sensor	EC-208. "Description"
Mass air flow sensor	EC-136. "Description"
Throttle position sensor	EC-155. "Description"

C

D

E

F

G

H

I

J

K

L

M

N

O

P

INTAKE VALVE TIMING CONTROL

[MR18DE]

< SYSTEM DESCRIPTION >

INTAKE VALVE TIMING CONTROL

System Diagram

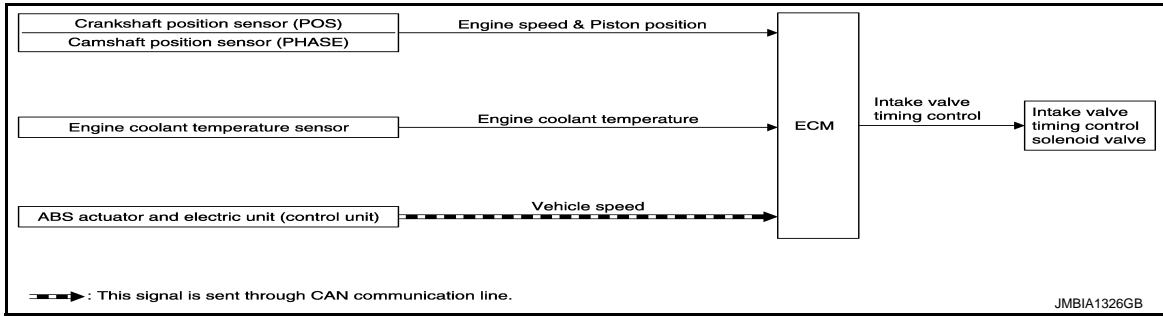

System Description

INFOID:000000004833185

INPUT/OUTPUT SIGNAL CHART

Sensor	Input signal to ECM	ECM function	Actuator
Crankshaft position sensor (POS)	Engine speed and piston position	Intake valve timing control	Intake valve timing control solenoid valve
Camshaft position sensor (PHASE)			
Engine coolant temperature sensor	Engine coolant temperature		
ABS actuator and electric unit (control unit)	Vehicle speed*		
Combination meter			

*: This signal is sent to the ECM via the CAN communication line

SYSTEM DESCRIPTION

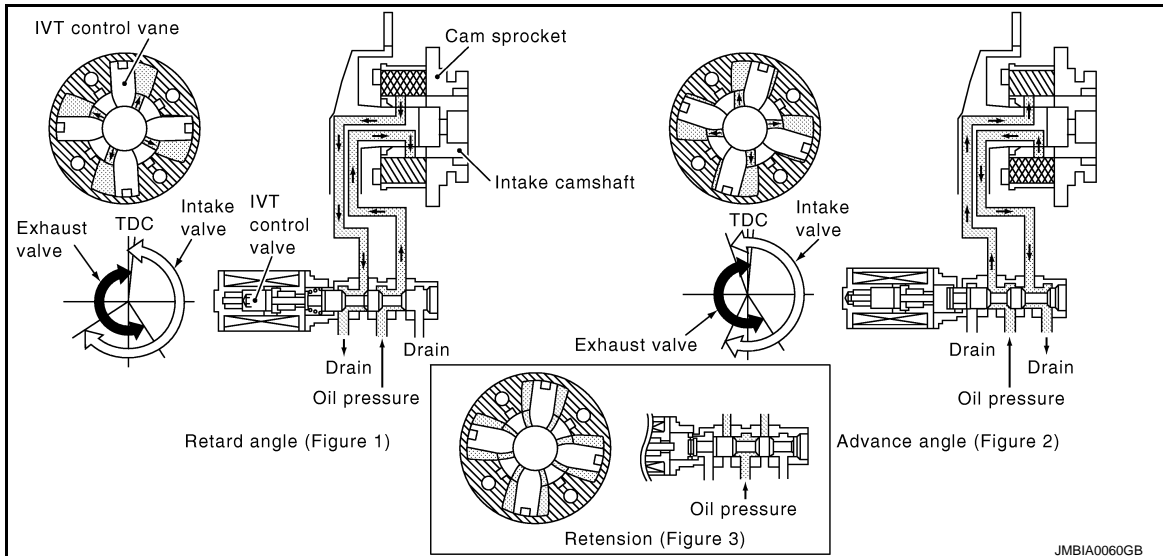

This mechanism hydraulically controls cam phases continuously with the fixed operating angle of the intake valve.

The ECM receives signals such as crankshaft position, camshaft position, engine speed, and engine coolant temperature. Then, the ECM sends ON/OFF pulse duty signals to the intake valve timing (IVT) control solenoid valve depending on driving status. This makes it possible to control the shut/open timing of the intake valve to increase engine torque in low/mid speed range and output in high-speed range.

INTAKE VALVE TIMING CONTROL

< SYSTEM DESCRIPTION >

[MR18DE]

Component Parts Location

INFOID:000000004833186

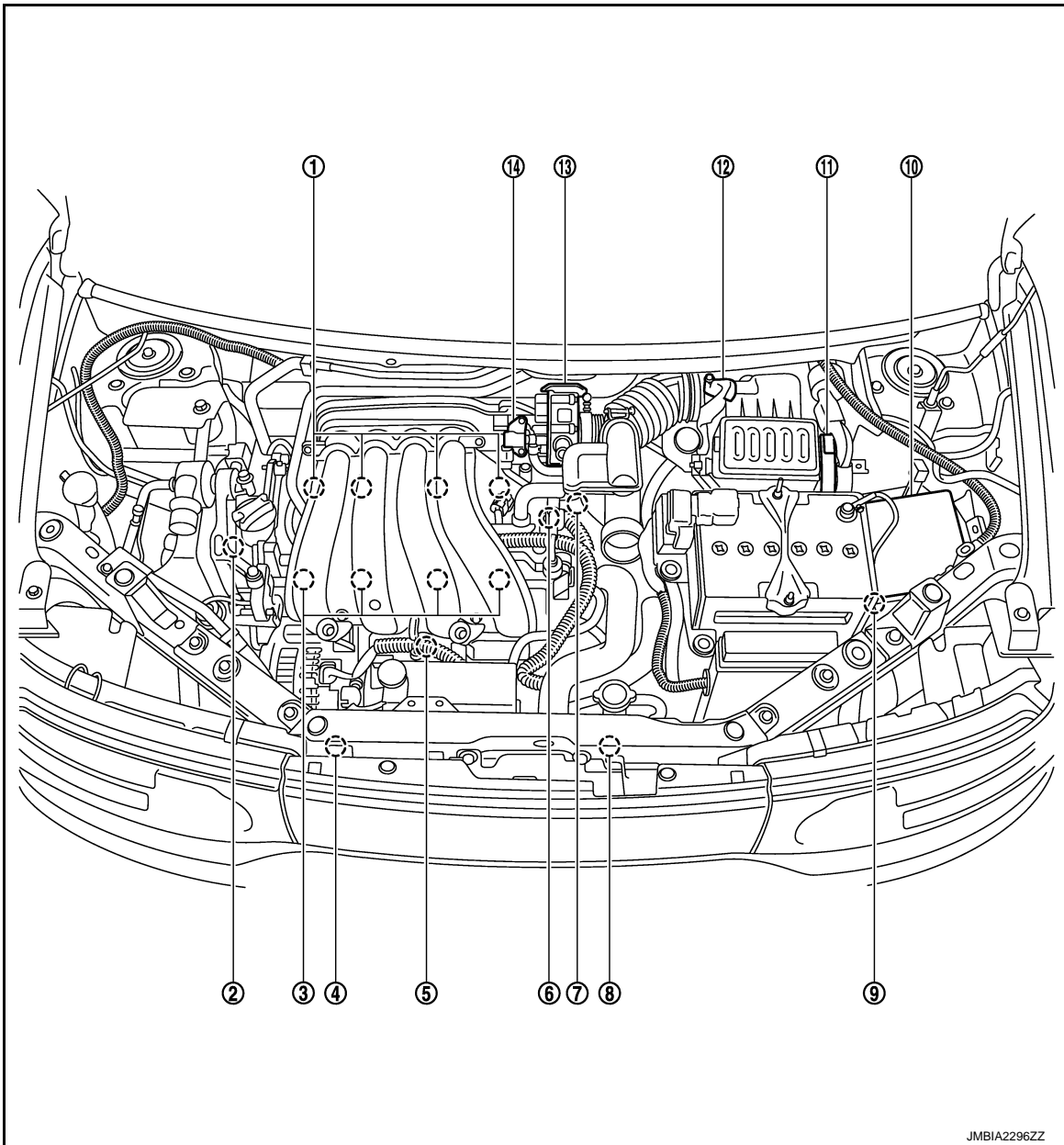

- | | | |
|--|---|---|
| 1. Ignition coil (with power transistor) and spark plug | 2. Intake valve timing control solenoid valve | 3. Fuel injector |
| 4. Refrigerant pressure sensor | 5. Knock sensor | 6. Camshaft position sensor (PHASE) |
| 7. Engine coolant temperature sensor | 8. Cooling fan motor | 9. Battery current sensor |
| 10. IPDM E/R | 11. ECM | 12. Mass air flow sensor (with intake air temperature sensor) |
| 13. Electric throttle control actuator (with built in throttle position sensor and throttle control motor) | 14. EVAP canister purge volume control solenoid valve | |

INTAKE VALVE TIMING CONTROL

< SYSTEM DESCRIPTION >

[MR18DE]

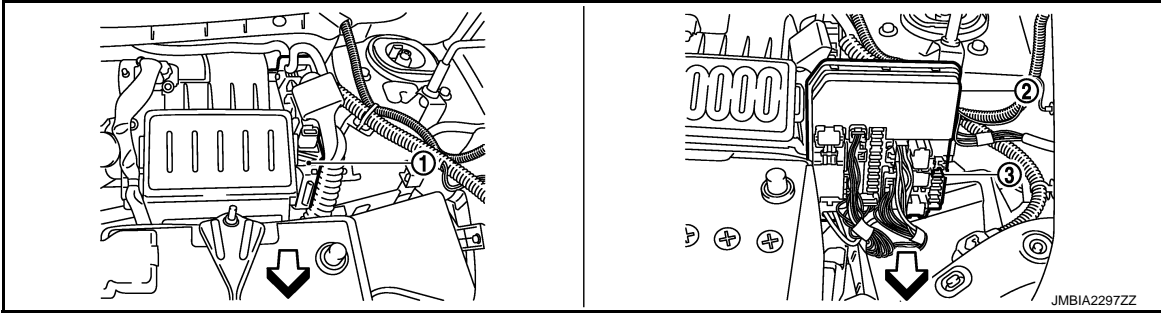

1. ECM

2. IPDM E/R

3. Fuel pump fuse (15 A)

↶ Vehicle front

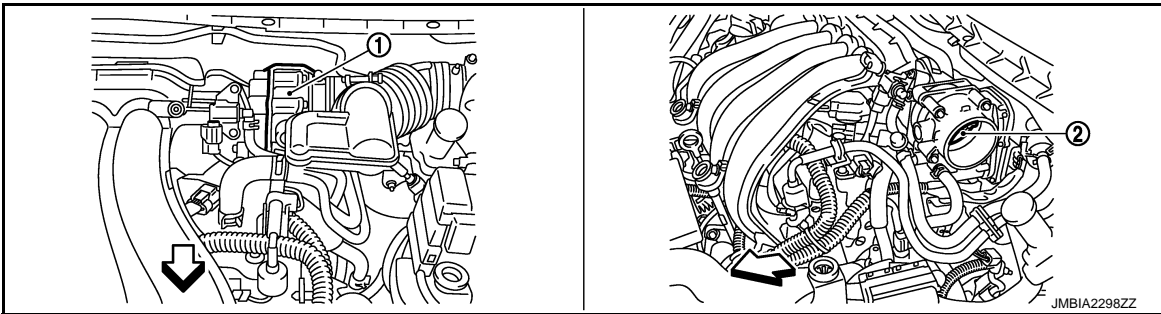

1. Electric throttle control actuator
(with built-in position sensor, throttle
control motor)

2. Throttle valve

↶ Vehicle front

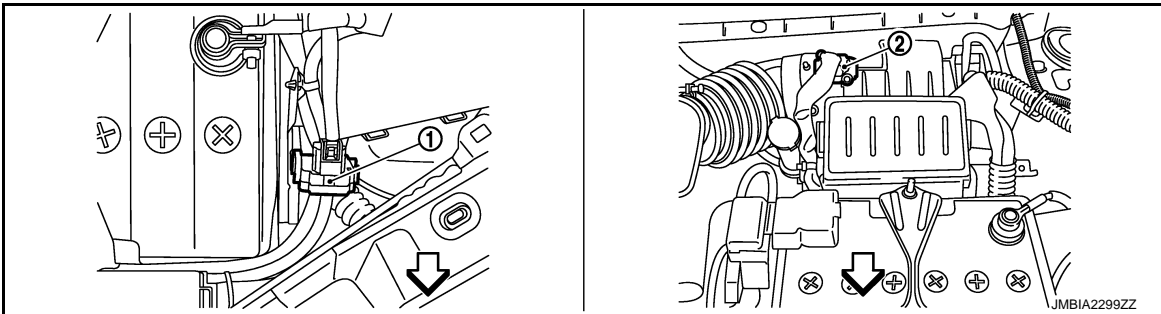

1. Battery current sensor

2. Mass air flow sensor
(with Intake air temperature sensor)

↶ Vehicle front

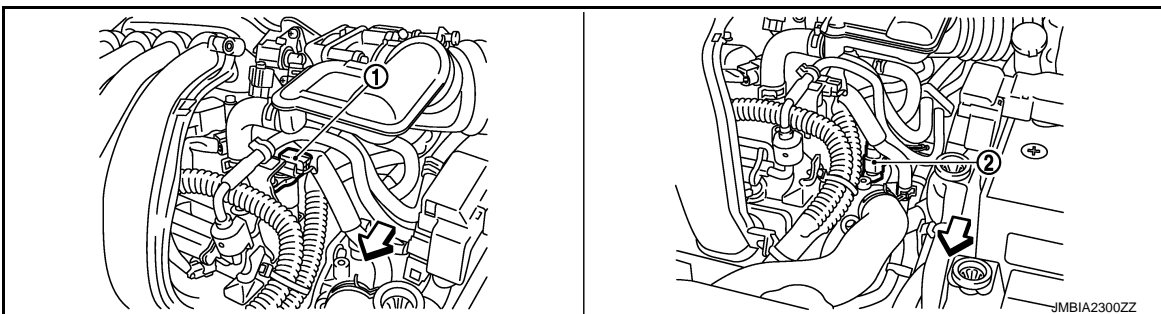

INTAKE VALVE TIMING CONTROL

[MR18DE]

< SYSTEM DESCRIPTION >

1. Camshaft position sensor (PHASE)
2. Engine coolant temperature sensor

← Vehicle front

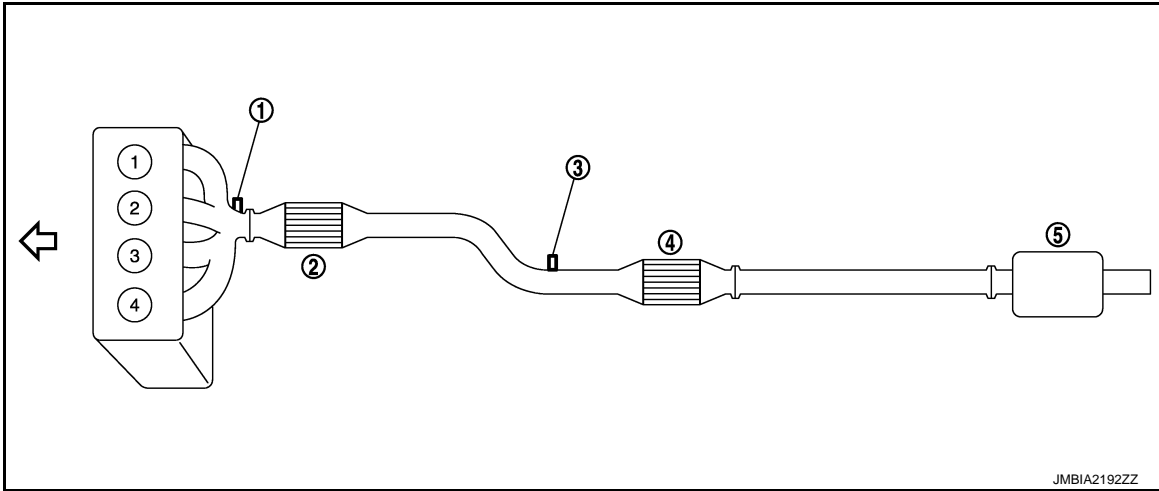

1. Air fuel ratio (A/F) sensor 1
2. Three way catalyst (Manifold)
3. Heated oxygen sensor 2
4. Three way catalyst (under floor)
5. Muffler

← Vehicle front

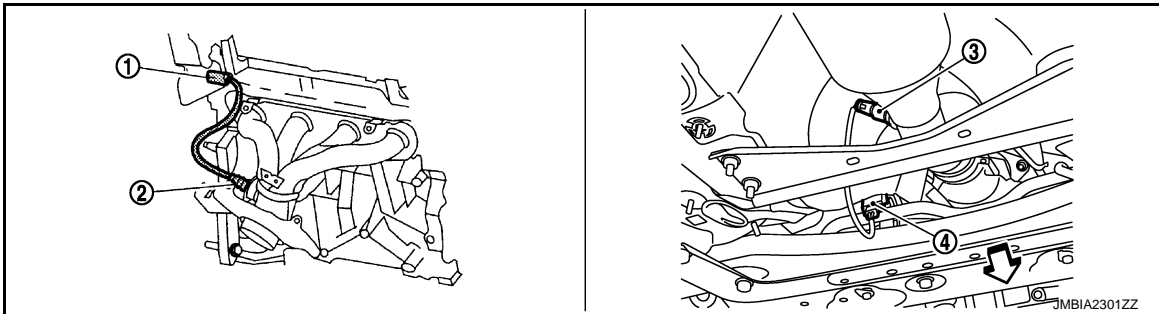

1. Air fuel ratio (A/F) sensor 1 harness connector
2. Air fuel ratio (A/F) sensor 1
3. Heated oxygen sensor 2
4. Heated oxygen sensor 2 harness connector

← Vehicle front

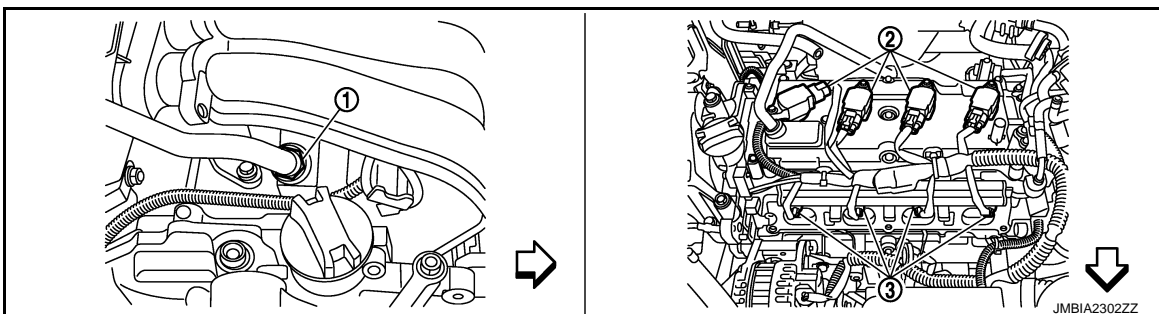

1. PCV valve
2. Ignition coil (with power transistor)
3. Fuel injector

← Vehicle front

A

EC

C

D

E

F

G

H

I

J

K

L

M

N

O

P

INTAKE VALVE TIMING CONTROL

< SYSTEM DESCRIPTION >

[MR18DE]

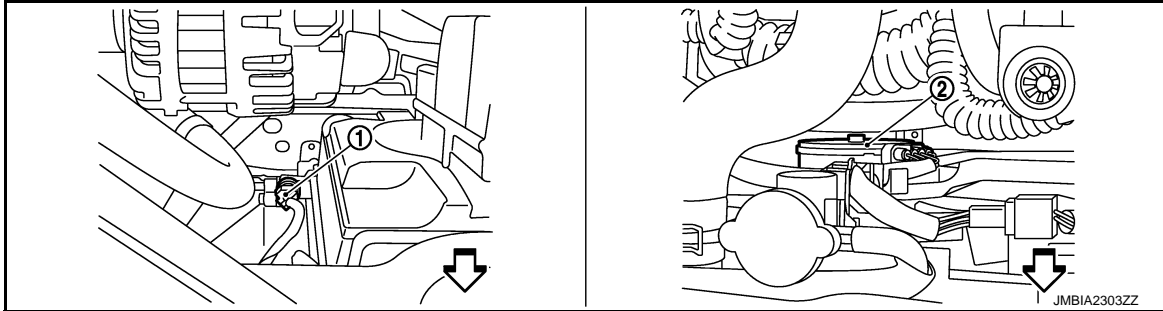

- 1. Refrigerant pressure sensor
- 2. Cooling fan motor

↶ Vehicle front

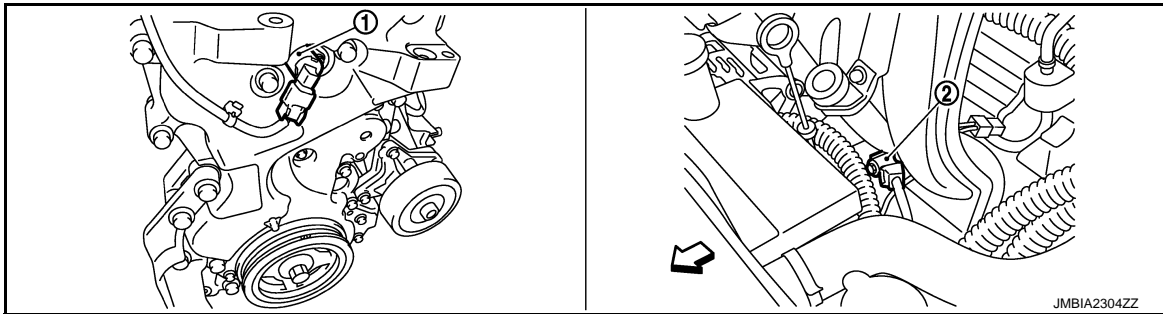

- 1. Intake valve timing control solenoid
- 2. Knock sensor valve

↶ Vehicle front

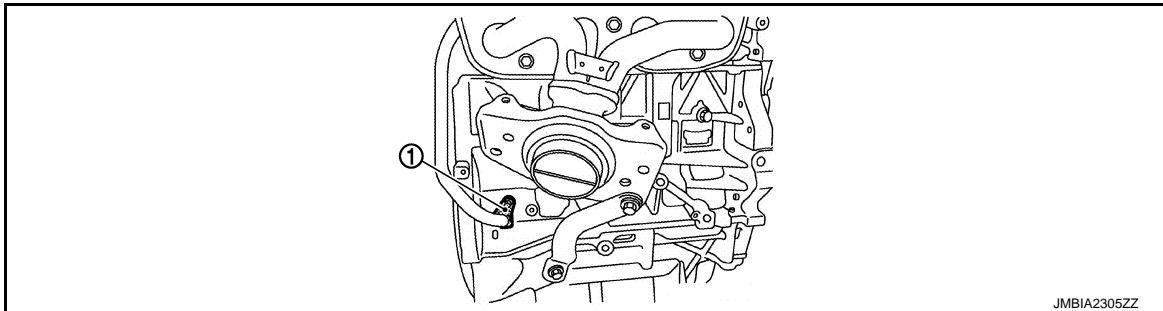

- 1. Crankshaft position sensor (POS)

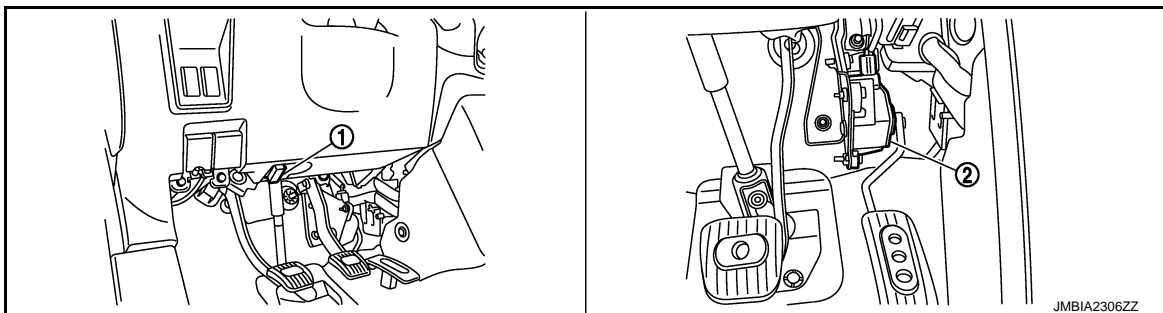

- 1. Data link connector
- 2. Accelerator pedal position sensor

INTAKE VALVE TIMING CONTROL

< SYSTEM DESCRIPTION >

[MR18DE]

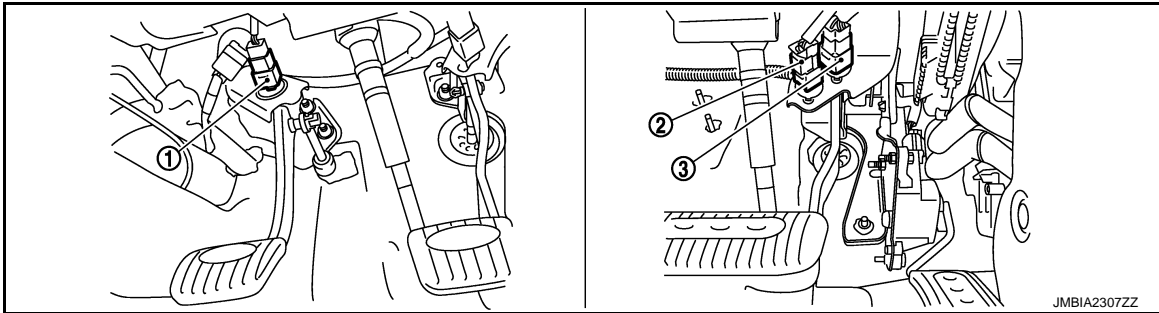

- 1. ASCD clutch switch
- 2. ASCD brake switch
- 3. Stop lamp switch

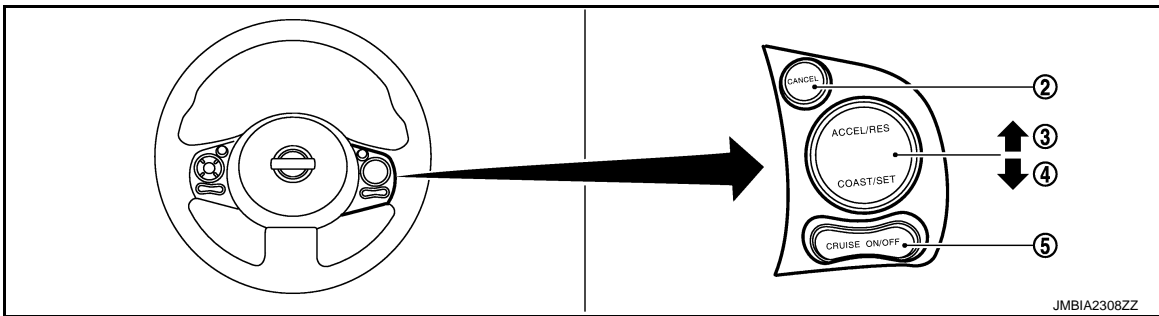

- 1. ASCD steering switch
- 2. CANCEL switch
- 3. RESUME/ACCELERATE switch
- 4. SET/COST switch
- 5. MAIN switch

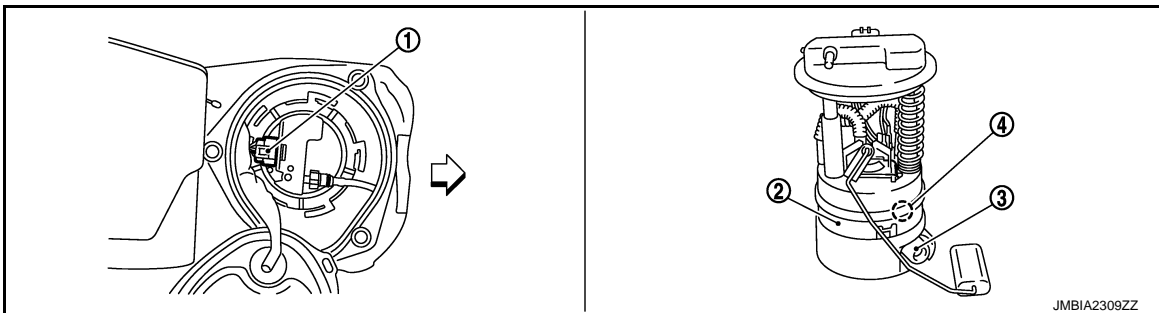

- 1. Fuel level sensor unit and fuel pump
- 2. Fuel level sensor unit and fuel pump harness connector
- 3. Fuel pressure regulator
- 4. Fuel tank temperature sensor

↶ Vehicle front

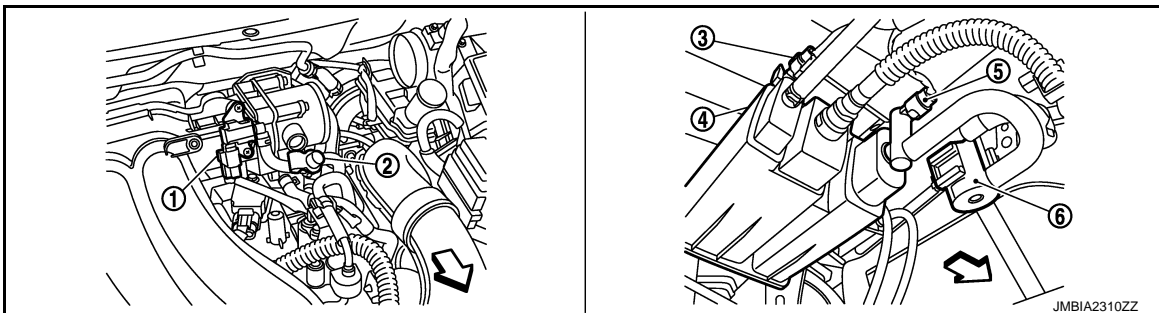

- 1. EVAP canister purge volume control
- 2. EVAP service port solenoid valve
- 3. EVAP control system pressure sensor

A
EC
C
D
E
F
G
H
I
J
K
L
M
N
O
P

INTAKE VALVE TIMING CONTROL

[MR18DE]

< SYSTEM DESCRIPTION >

- 4. EVAP canister
 - 5. EVAP canister vent control valve
 - 6. Drain filter
- ↩ Vehicle front

Component Description

INFOID:000000004833187

Component	Reference
Camshaft position sensor (PHASE)	EC-229. "Description"
Crankshaft position sensor (POS)	EC-225. "Description"
Engine coolant temperature sensor	EC-152. "Description"
Intake valve timing control solenoid valve	EC-78. "System Description"

ON BOARD DIAGNOSTIC (OBD) SYSTEM

< SYSTEM DESCRIPTION >

[MR18DE]

ON BOARD DIAGNOSTIC (OBD) SYSTEM

Diagnosis Description

INFOID:000000004833188

INTRODUCTION

The ECM has an on board diagnostic system, which detects malfunctions related to engine sensors or actuators. The ECM also records various emission-related diagnostic information including:

Emission-related diagnostic information	Diagnostic service
Diagnostic Trouble Code (DTC)	Service \$03 of SAE J1979
Freeze Frame data	Service \$02 of SAE J1979
System Readiness Test (SRT) code	Service \$01 of SAE J1979
1st Trip Diagnostic Trouble Code (1st Trip DTC)	Service \$07 of SAE J1979
1st Trip Freeze Frame data	
Test values and Test limits	Service \$06 of SAE J1979
Calibration ID	Service \$09 of SAE J1979

The above information can be checked using procedures listed in the table below.

x: Applicable —: Not applicable

	DTC	1st trip DTC	Freeze Frame data	1st trip Freeze Frame data	SRT code	SRT status	Test value
CONSULT-III	x	x	x	x	x	x	—
GST	x	x	x	—	x	x	x
ECM	x	x*	—	—	—	x	—

*: When DTC and 1st trip DTC simultaneously appear on the display, they cannot be clearly distinguished from each other.

The malfunction indicator lamp (MIL) on the instrument panel lights up when the same malfunction is detected in two consecutive trips (Two trip detection logic), or when the ECM enters fail-safe mode. (Refer to [EC-445, "Fail Safe"](#).)

TWO TRIP DETECTION LOGIC

When a malfunction is detected for the first time, 1st trip DTC and 1st trip Freeze Frame data are stored in the ECM memory. The MIL will not light up at this stage. <1st trip>

If the same malfunction is detected again during the next drive, the DTC and Freeze Frame data are stored in the ECM memory, and the MIL lights up. The MIL lights up at the same time when the DTC is stored. <2nd trip> The "trip" in the "Two Trip Detection Logic" means a driving mode in which self-diagnosis is performed during vehicle operation. Specific on board diagnostic items will cause the ECM to light up or blink the MIL, and store DTC and Freeze Frame data, even in the 1st trip, as shown below.

x: Applicable —: Not applicable

Items	MIL				DTC		1st trip DTC	
	1st trip		2nd trip		1st trip displaying	2nd trip displaying	1st trip displaying	2nd trip displaying
	Blinking	Lighting up	Blinking	Lighting up				
Misfire (Possible three way catalyst damage) — DTC: P0300 - P0304 is being detected	x	—	—	—	—	—	x	—
Misfire (Possible three way catalyst damage) — DTC: P0300 - P0304 is being detected	—	—	x	—	—	x	—	—
One trip detection diagnoses (Refer to EC-448, "DTC Index" .)	—	x	—	—	x	—	—	—
Except above	—	—	—	x	—	x	x	—

DTC AND FREEZE FRAME DATA

DTC and 1st Trip DTC

ON BOARD DIAGNOSTIC (OBD) SYSTEM

[MR18DE]

< SYSTEM DESCRIPTION >

The 1st trip DTC (whose number is the same as the DTC number) is displayed for the latest self-diagnostic result obtained. If the ECM memory was cleared previously, and the 1st trip DTC did not recur, the 1st trip DTC will not be displayed.

If a malfunction is detected during the 1st trip, the 1st trip DTC is stored in the ECM memory. The MIL will not light up (two trip detection logic). If the same malfunction is not detected in the 2nd trip (meeting the required driving pattern), the 1st trip DTC is cleared from the ECM memory. If the same malfunction is detected in the 2nd trip, both the 1st trip DTC and DTC are stored in the ECM memory and the MIL lights up. In other words, the DTC is stored in the ECM memory and the MIL lights up when the same malfunction occurs in two consecutive trips. If a 1st trip DTC is stored and a non-diagnostic operation is performed between the 1st and 2nd trips, only the 1st trip DTC will continue to be stored. For malfunctions that blink or light up the MIL during the 1st trip, the DTC and 1st trip DTC are stored in the ECM memory.

Procedures for clearing the DTC and the 1st trip DTC from the ECM memory are described in “How to Erase DTC and 1st Trip DTC”.

For malfunctions in which 1st trip DTCs are displayed, refer to [EC-448, "DTC Index"](#). These items are required by legal regulations to continuously monitor the system/component. In addition, the items monitored non-continuously are also displayed on CONSULT-III.

1st trip DTC is specified in Service \$07 of SAE J1979. 1st trip DTC detection occurs without lighting up the MIL and therefore does not warn the driver of a malfunction. However, 1st trip DTC detection will not prevent the vehicle from being tested, for example during Inspection/Maintenance (I/M) tests.

When a 1st trip DTC is detected, check, print out or write down and erase (1st trip) DTC and Freeze Frame data as specified in Work Flow procedure Step 2, refer to [EC-8, "Work Flow"](#). Then perform DTC CONFIRMATION PROCEDURE or Component Function Check to try to duplicate the malfunction. If the malfunction is duplicated, the item requires repair.

Freeze Frame Data and 1st Trip Freeze Frame Data

The ECM records the driving conditions such as fuel system status, calculated load value, engine coolant temperature, short-term fuel trim, long-term fuel trim, engine speed, vehicle speed, absolute throttle position, base fuel schedule and intake air temperature at the moment a malfunction is detected.

Data which are stored in the ECM memory, along with the 1st trip DTC, are called 1st trip freeze frame data. The data, stored together with the DTC data, are called freeze frame data and displayed on CONSULT-III or GST. The 1st trip freeze frame data can only be displayed on the CONSULT-III screen, not on the GST.

Only one set of freeze frame data (either 1st trip freeze frame data or freeze frame data) can be stored in the ECM. 1st trip freeze frame data is stored in the ECM memory along with the 1st trip DTC. There is no priority for 1st trip freeze frame data and it is updated each time a different 1st trip DTC is detected. However, once freeze frame data (2nd trip detection/MIL on) is stored in the ECM memory, 1st trip freeze frame data is no longer stored. Remember, only one set of freeze frame data can be stored in the ECM. The ECM has the following priorities to update the data.

Priority	Items	
1	Freeze frame data	Misfire — DTC: P0300 - P0304 Fuel Injection System Function — DTC: P0171, P0172
2		Except the above items (Includes CVT related items)
3	1st trip freeze frame data	

For example, the EGR malfunction (Priority: 2) was detected and the freeze frame data was stored in the 2nd trip. After that when the misfire (Priority: 1) is detected in another trip, the freeze frame data will be updated from the EGR malfunction to the misfire. The 1st trip freeze frame data is updated each time a different malfunction is detected. There is no priority for 1st trip freeze frame data. However, once freeze frame data is stored in the ECM memory, 1st trip freeze data is no longer stored (because only one freeze frame data or 1st trip freeze frame data can be stored in the ECM). If freeze frame data is stored in the ECM memory and freeze frame data with the same priority occurs later, the first (original) freeze frame data remains unchanged in the ECM memory.

Both 1st trip freeze frame data and freeze frame data (along with the DTCs) are cleared when the ECM memory is erased. Procedures for clearing the ECM memory are described in “How to Erase DTC and 1st Trip DTC”.

How to Read DTC and 1st Trip DTC

DTC and 1st trip DTC can be read by the following methods.

With CONSULT-III

CONSULT-III displays the DTC in “SELF DIAGNOSTIC RESULT” mode.

Examples: P0340, P0850, P1148, etc.

ON BOARD DIAGNOSTIC (OBD) SYSTEM

[MR18DE]

< SYSTEM DESCRIPTION >

These DTCs are prescribed by SAE J2012.

(CONSULT-III also displays the malfunctioning component or system.)

Time data indicates how many times the vehicle was driven after the last detection of a DTC.

If the DTC is being detected currently, the time data will be [0].

If a 1st trip DTC is stored in the ECM, the time data will be [1t].

With GST

GST (Generic Scan Tool) displays the DTC in Diagnostic Service \$03.

Examples: P0340, P0850, P1148, etc.

These DTCs are prescribed by SAE J2012.

No Tools

The number of blinks of the MIL in the Diagnostic Test Mode II (Self-Diagnostic Results) indicates the DTC.

Example: 0340, 0850, 1148, etc.

These DTCs are controlled by NISSAN.

NOTE:

- 1st trip DTC No. is the same as DTC No.
- Output of a DTC indicates a malfunction. However, GST and the Diagnostic Test Mode II do not indicate whether the malfunction is still occurring or has occurred in the past and has returned to normal. CONSULT-III can identify malfunction status. Therefore, using CONSULT-III (if available) is recommended.

How to Erase DTC and 1st Trip DTC

With CONSULT-III

NOTE:

- If the ignition switch stays ON after repair work, be sure to turn ignition switch OFF once. Wait at least 10 seconds and then turn it ON (engine stopped) again.

- If the DTC is not for CVT related items ([EC-448, "DTC Index"](#)), skip step 1.

1. Erase DTC in TCM. Refer to [TM-91, "Diagnosis Description"](#).
2. Select "ENGINE" with CONSULT-III.
3. Select "SELF DIAGNOSTIC RESULT".
4. Touch "ERASE". (DTC in ECM will be erased.)

With GST

NOTE:

If the ignition switch stays ON after repair work, be sure to turn ignition switch OFF once. Wait at least 10 seconds and then turn it ON (engine stopped) again.

1. Select Service \$04 with GST (Generic Scan Tool).

No Tools

NOTE:

If the ignition switch stays ON after repair work, be sure to turn ignition switch OFF once. Wait at least 10 seconds and then turn it ON (engine stopped) again.

1. Erase DTC in ECM. Refer to HOW TO ERASE DIAGNOSTIC TEST MODE II (SELF-DIAGNOSTIC RESULTS).

- If the battery is disconnected, the emission-related diagnostic information will be cleared within 24 hours.

- The following data are cleared when the ECM memory is erased.

- Diagnostic trouble codes
- 1st trip diagnostic trouble codes
- Freeze frame data
- 1st trip freeze frame data
- System readiness test (SRT) codes
- Test values

Actual work procedures are explained using a DTC as an example. Be careful so that not only the DTC, but all of the data listed above, are cleared from the ECM memory during work procedures.

SYSTEM READINESS TEST (SRT) CODE

System Readiness Test (SRT) code is specified in Service \$01 of SAE J1979.

As part of an enhanced emissions test for Inspection & Maintenance (I/M), certain states require the status of SRT be used to indicate whether the ECM has completed self-diagnosis of major emission systems and components. Completion must be verified in order for the emissions inspection to proceed.

If a vehicle is rejected for a State emissions inspection due to one or more SRT items indicating "INCMP", use the information in this Service Manual to set the SRT to "CMPLT".

ON BOARD DIAGNOSTIC (OBD) SYSTEM

[MR18DE]

< SYSTEM DESCRIPTION >

In most cases the ECM will automatically complete its self-diagnosis cycle during normal usage, and the SRT status will indicate "CMPLT" for each application system. Once set as "CMPLT", the SRT status remains "CMPLT" until the self-diagnosis memory is erased.

Occasionally, certain portions of the self-diagnostic test may not be completed as a result of the customer's normal driving pattern; the SRT will indicate "INCMP" for these items.

NOTE:

The SRT will also indicate "INCMP" if the self-diagnosis memory is erased for any reason or if the ECM memory power supply is interrupted for several hours.

If, during the state emissions inspection, the SRT indicates "CMPLT" for all test items, the inspector will continue with the emissions test. However, if the SRT indicates "INCMP" for one or more of the SRT items the vehicle is returned to the customer untested.

NOTE:

If MIL is ON during the state emissions inspection, the vehicle is also returned to the customer untested even though the SRT indicates "CMPLT" for all test items. Therefore, it is important to check SRT ("CMPLT") and DTC (No DTCs) before the inspection.

SRT Item

The table below shows required self-diagnostic items to set the SRT to "CMPLT".

SRT item (CONSULT-III indication)	Performance Priority*	Required self-diagnostic items to set the SRT to "CMPLT"	Corresponding DTC No.
CATALYST	2	Three way catalyst function	P0420
EVAP SYSTEM	2	EVAP control system purge flow monitoring	P0441
	1	EVAP control system	P0442
	2	EVAP control system	P0456
HO2S	2	Air fuel ratio (A/F) sensor 1	P0133
		Heated oxygen sensor 2	P0137
		Heated oxygen sensor 2	P0138
		Heated oxygen sensor 2	P0139
EGR/VVT SYSTEM	3	Intake valve timing control function	P0011

*: If completion of several SRTs is required, perform driving patterns (DTC CONFIRMATION PROCEDURE), one by one based on the priority for models with CONSULT-III.

SRT Set Timing

SRT is set as "CMPLT" after self-diagnosis has been performed one or more times. Completion of SRT is done regardless of whether the result is OK or NG. The set timing is different between OK and NG results and is shown in the table below.

Self-diagnosis result		Example				
		Diagnosis	Ignition cycle ← ON → OFF ← ON → OFF ← ON → OFF ← ON →			
All OK	Case 1	P0400	OK (1)	— (1)	OK (2)	— (2)
		P0402	OK (1)	— (1)	— (1)	OK (2)
		P1402	OK (1)	OK (2)	— (2)	— (2)
		SRT of EGR	"CMPLT"	"CMPLT"	"CMPLT"	"CMPLT"
	Case 2	P0400	OK (1)	— (1)	— (1)	— (1)
		P0402	— (0)	— (0)	OK (1)	— (1)
		P1402	OK (1)	OK (2)	— (2)	— (2)
		SRT of EGR	"INCMP"	"INCMP"	"CMPLT"	"CMPLT"

ON BOARD DIAGNOSTIC (OBD) SYSTEM

< SYSTEM DESCRIPTION >

[MR18DE]

NG exists	Case 3	P0400	OK	OK	—	—
		P0402	—	—	—	—
		P1402	NG	—	NG	NG (Consecutive NG)
		(1st trip) DTC	1st trip DTC	—	1st trip DTC	DTC (= MIL ON)
		SRT of EGR	"INCMP"	"INCMP"	"INCMP"	"CMPLT"

OK: Self-diagnosis is carried out and the result is OK.

NG: Self-diagnosis is carried out and the result is NG.

—: Self-diagnosis is not carried out.

When all SRT related self-diagnoses showed OK results in a single cycle (Ignition OFF-ON-OFF), the SRT will indicate "CMPLT". → Case 1 above

When all SRT related self-diagnoses showed OK results through several different cycles, the SRT will indicate "CMPLT" at the time the respective self-diagnoses have at least one OK result. → Case 2 above

If one or more SRT related self-diagnoses showed NG results in 2 consecutive cycles, the SRT will also indicate "CMPLT". → Case 3 above

The table above shows that the minimum number of cycles for setting SRT as "INCMP" is one (1) for each self-diagnosis (Case 1 & 2) or two (2) for one of self-diagnoses (Case 3). However, in preparation for the state emissions inspection, it is unnecessary for each self-diagnosis to be executed twice (Case 3) for the following reasons:

- The SRT will indicate "CMPLT" at the time the respective self-diagnoses have one (1) OK result.
- The emissions inspection requires "CMPLT" of the SRT only with OK self-diagnosis results.
- When, during SRT driving pattern, 1st trip DTC (NG) is detected prior to "CMPLT" of SRT, the self-diagnosis memory must be erased from ECM after repair.
- If the 1st trip DTC is erased, all the SRT will indicate "INCMP".

NOTE:

SRT can be set as "CMPLT" together with the DTC(s). Therefore, DTC check must always be carried out prior to the state emission inspection even though the SRT indicates "CMPLT".

SRT Service Procedure

A
EC
C
D
E
F
G
H
I
J
K
L
M
N
O
P

ON BOARD DIAGNOSTIC (OBD) SYSTEM

[MR18DE]

< SYSTEM DESCRIPTION >

If a vehicle has failed the state emissions inspection due to one or more SRT items indicating "INCMP", review the flowchart diagnostic sequence on the next figure.

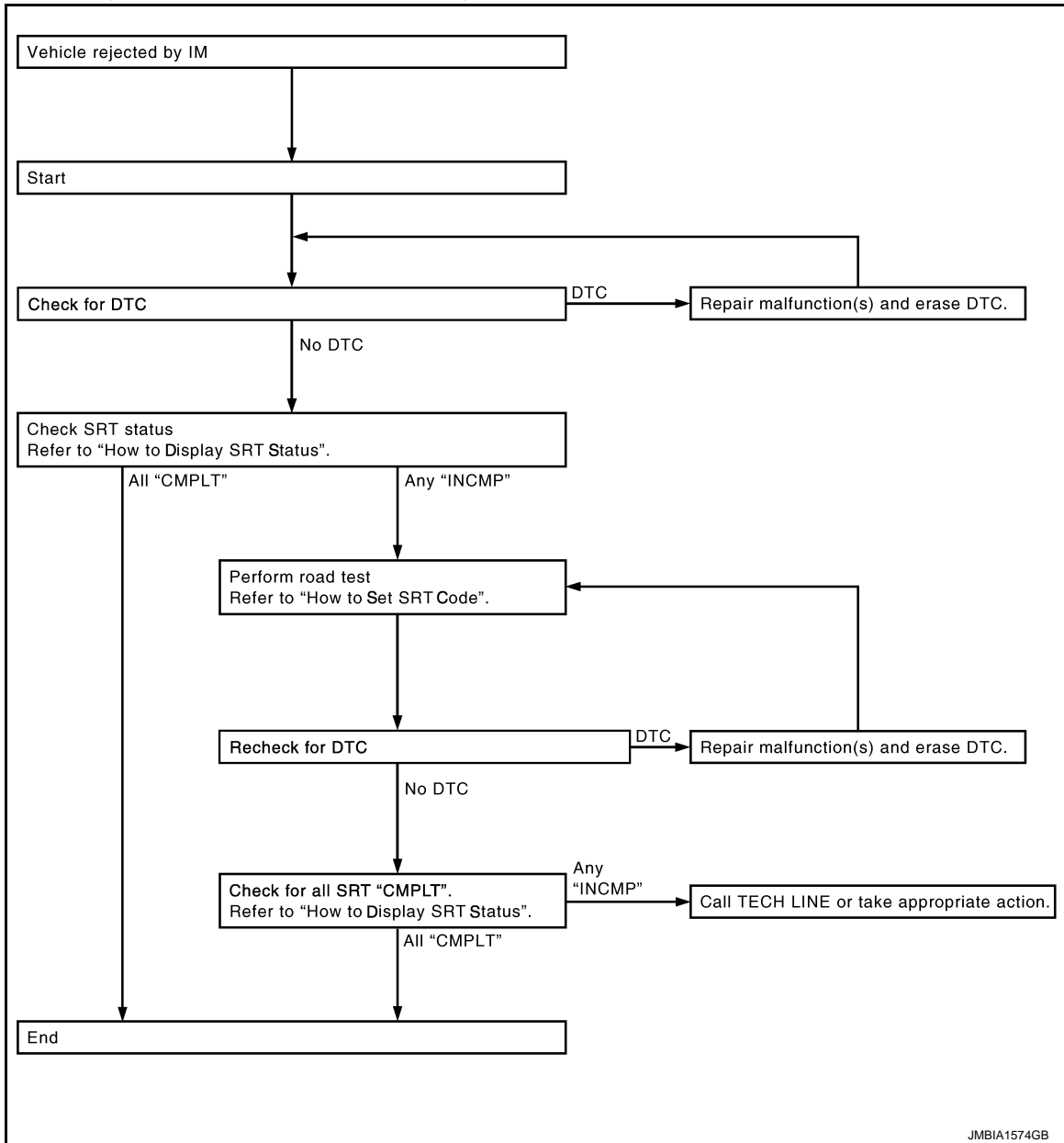

How to Display SRT Status

WITH CONSULT-III

Selecting "SRT STATUS" in "DTC CONFIRMATION" mode with CONSULT-III.

For items whose SRT codes are set, a "CMPLT" is displayed on the CONSULT-III screen; for items whose SRT codes are not set, "INCMP" is displayed.

NOTE:

Though displayed on the CONSULT-III screen, "HO2S HTR" is not SRT item.

WITH GST

Selecting Service \$01 with GST (Generic Scan Tool)

NO TOOLS

A SRT code itself can not be displayed while only SRT status can be.

1. Turn ignition switch ON and wait 20 seconds.
2. SRT status is indicated as shown below.
 - When all SRT codes are set, MIL lights up continuously.

ON BOARD DIAGNOSTIC (OBD) SYSTEM

[MR18DE]

< SYSTEM DESCRIPTION >

- When any SRT codes are not set, MIL will flash periodically for 10 seconds.

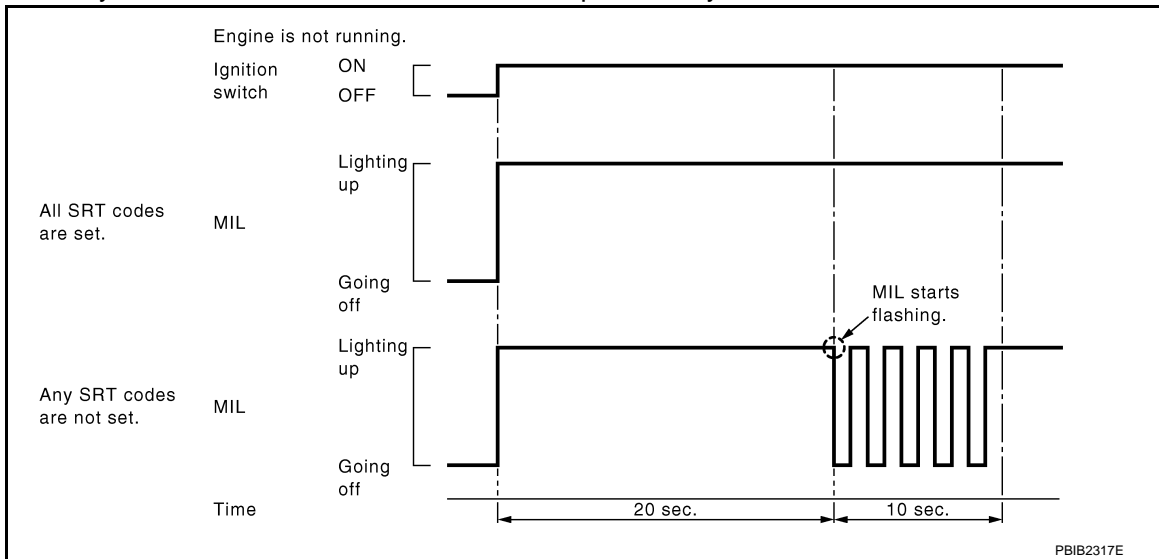

MALFUNCTION INDICATOR LAMP (MIL)

Description

The MIL is located on the instrument panel.

- The MIL will light up when the ignition switch is turned ON without the engine running. This is a bulb check. If the MIL does not light up, refer to [EC-406. "Component Function Check"](#).
- When the engine is started, the MIL should go off. If the MIL remains on, the on board diagnostic system has detected an engine system malfunction.

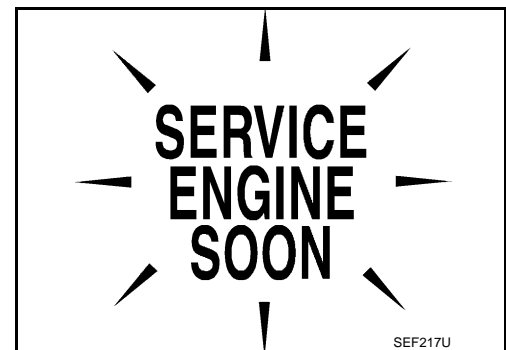





On Board Diagnostic System Function

The on board diagnostic system has the following three functions.

ON BOARD DIAGNOSTIC (OBD) SYSTEM

[MR18DE]

< SYSTEM DESCRIPTION >

Diagnostic Test Mode	KEY and ENG. Status	Function	Explanation of Function
Mode I	Ignition switch in ON position  Engine stopped 	BULB CHECK	This function checks the MIL bulb for damage (blown, open circuit, etc.). If the MIL does not come on, check MIL circuit.
	Engine running 	MALFUNCTION WARNING	When a malfunction is detected twice in two consecutive driving cycles (two trip detection logic), the MIL will light up to inform the driver that a malfunction has been detected. The following malfunctions will light up or blink the MIL in the 1st trip. <ul style="list-style-type: none"> • Misfire (Possible three way catalyst damage) • One trip detection diagnoses
Mode II	Ignition switch in ON position  Engine stopped 	SELF-DIAGNOSTIC RESULTS	This function allows DTCs and 1st trip DTCs to be read.

Diagnostic Test Mode I — Bulb Check

In this mode, the MIL on the instrument panel should stay ON. If it remains OFF, check the bulb. Refer to [EC-406. "Description"](#).

Diagnostic Test Mode I — Malfunction Warning

MIL	Condition
ON	When the malfunction is detected.
OFF	No malfunction.

This DTC number is clarified in Diagnostic Test Mode II (SELF-DIAGNOSTIC RESULTS)

Diagnostic Test Mode II — Self-diagnostic Results

In this mode, the DTC and 1st trip DTC are indicated by the number of blinks of the MIL as shown below. The DTC and 1st trip DTC are displayed at the same time. If the MIL does not illuminate in diagnostic test mode I (Malfunction warning), all displayed items are 1st trip DTCs. If only one code is displayed when the MIL illuminates in diagnostic test mode II (SELF-DIAGNOSTIC RESULTS), it is a DTC; if two or more codes are displayed, they may be either DTCs or 1st trip DTCs. DTC No. is same as that of 1st trip DTC. These uniden-

ON BOARD DIAGNOSTIC (OBD) SYSTEM

[MR18DE]

< SYSTEM DESCRIPTION >

Identified codes can be identified by using the CONSULT-III or GST. A DTC will be used as an example for how to read a code.

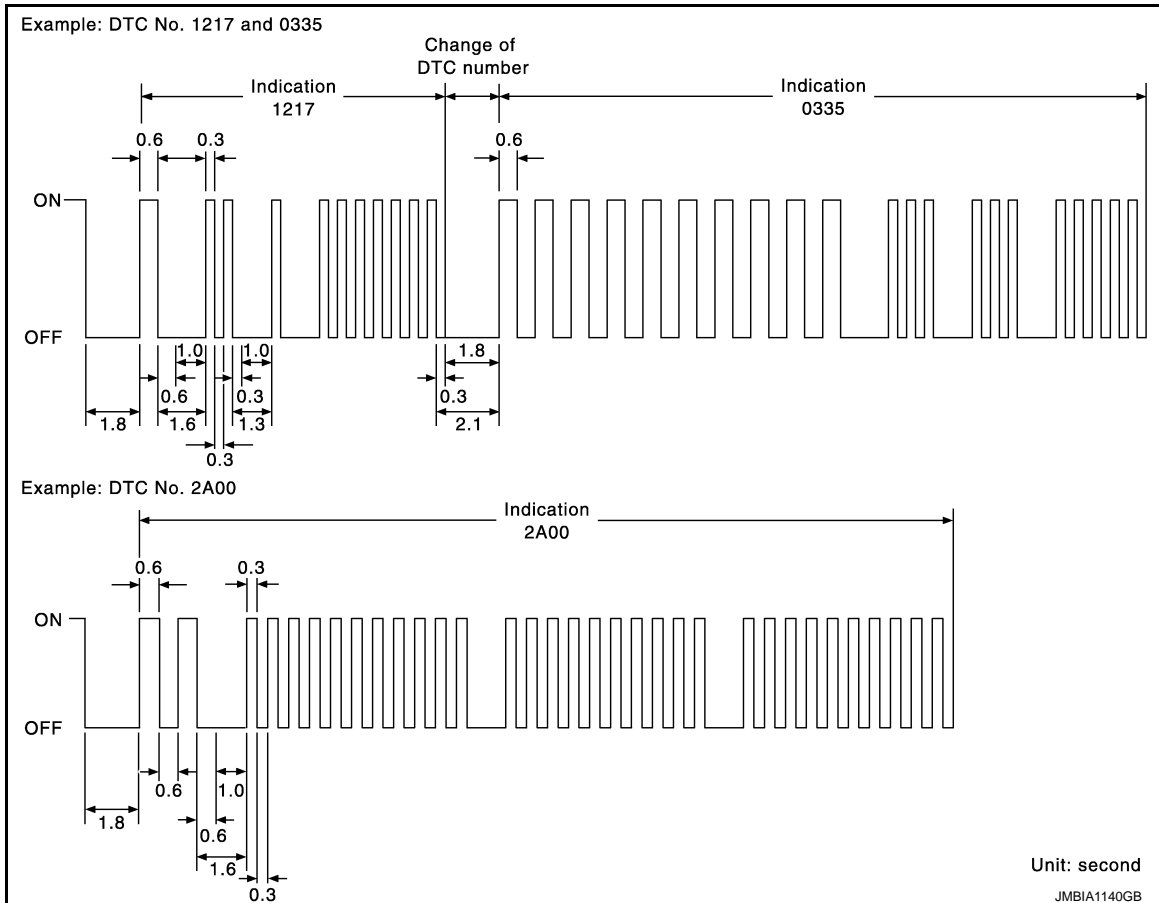

A particular trouble code can be identified by the number of four-digit numeral flashes as per the following.

Number	0	1	2	3	4	5	6	7	8	9	A	B	C	D	E	F
Flashes	10	1	2	3	4	5	6	7	8	9	11	12	13	14	15	16

The length of time the 1,000th-digit numeral flashes on and off is 1.2 seconds consisting of an ON (0.6-seconds) - OFF (0.6-seconds) cycle.

The 100th-digit numeral and lower digit numerals consist of a 0.3-seconds ON and 0.3-seconds OFF cycle.

A change from one digit numeral to another occurs at an interval of 1.0-second OFF. In other words, the later numeral appears on the display 1.3 seconds after the former numeral has disappeared.

A change from one trouble code to another occurs at an interval of 1.8-seconds OFF.

In this way, all the detected malfunctions are classified by their DTC numbers. The DTC 0000 refers to no malfunction. (See [EC-448, "DTC Index"](#))

How to Switch Diagnostic Test Mode

NOTE:

- It is better to count the time accurately with a clock.
- It is impossible to switch the diagnostic mode when an accelerator pedal position sensor circuit has a malfunction.
- Always ECM returns to Diagnostic Test Mode I after ignition switch is turned OFF.

HOW TO SET DIAGNOSTIC TEST MODE II (SELF-DIAGNOSTIC RESULTS)

1. Confirm that accelerator pedal is fully released, turn ignition switch ON and wait 3 seconds.
2. Repeat the following procedure quickly five times within 5 seconds.
 - Fully depress the accelerator pedal.
 - Fully release the accelerator pedal.
3. Wait 7 seconds, fully depress the accelerator pedal and keep it for approx. 10 seconds until the MIL starts blinking.

NOTE:

Do not release the accelerator pedal for 10 seconds if MIL start blinking during this period. This blinking is displaying SRT status and is continued for another 10 seconds.

ON BOARD DIAGNOSTIC (OBD) SYSTEM

[MR18DE]

< SYSTEM DESCRIPTION >

4. Fully release the accelerator pedal.
ECM has entered to Diagnostic Test Mode II (Self-diagnostic results).

NOTE:

Wait until the same DTC (or 1st trip DTC) appears to completely confirm all DTCs.

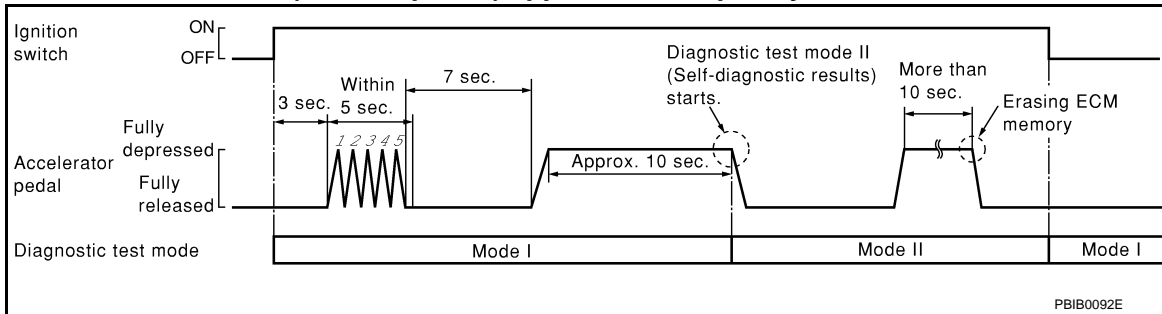

HOW TO ERASE DIAGNOSTIC TEST MODE II (SELF-DIAGNOSTIC RESULTS)

1. Set ECM in Diagnostic Test Mode II (Self-diagnostic results). Refer to “HOW TO SET DIAGNOSTIC TEST MODE II (SELF-DIAGNOSTIC RESULTS)”.
2. Fully depress the accelerator pedal and keep it for more than 10 seconds.
The emission-related diagnostic information has been erased from the backup memory in the ECM.
3. Fully release the accelerator pedal, and confirm the DTC 0000 is displayed.

OBD System Operation Chart

Relationship Between MIL, 1st Trip DTC, DTC and Detectable Items

- When a malfunction is detected for the first time, the 1st trip DTC and the 1st trip freeze frame data are stored in the ECM memory.
- When the same malfunction is detected in two consecutive trips, the DTC and the freeze frame data are stored in the ECM memory, and the MIL will come on.
- The MIL will go off after the vehicle is driven 3 times (driving pattern B) with no malfunction. The drive is counted only when the recorded driving pattern is met (as stored in the ECM). If another malfunction occurs while counting, the counter will reset.
- The DTC and the freeze frame data will be stored until the vehicle is driven 40 times (driving pattern A) without the same malfunction recurring (except for Misfire and Fuel Injection System). For Misfire and Fuel Injection System, the DTC and freeze frame data will be stored until the vehicle is driven 80 times (driving pattern C) without the same malfunction recurring. The “TIME” in “SELF DIAGNOSTIC RESULT” mode of CONSULT-III will count the number of times the vehicle is driven.
- The 1st trip DTC is not displayed when the self-diagnosis results in OK for the 2nd trip.

Summary Chart

Items	Fuel Injection System	Misfire	Other
MIL (goes off)	3 (pattern B)	3 (pattern B)	3 (pattern B)
DTC, Freeze Frame Data (no display)	80 (pattern C)	80 (pattern C)	40 (pattern A)
1st Trip DTC (clear)	1 (pattern C), *1	1 (pattern C), *1	1 (pattern B)
1st Trip Freeze Frame Data (clear)	*1, *2	*1, *2	1 (pattern B)

For details about patterns B and C under “Fuel Injection System” and “Misfire”, see “EXPLANATION FOR DRIVING PATTERNS FOR “MISFIRE <EXHAUST QUALITY DETERIORATION>”, “FUEL INJECTION SYSTEM”.

For details about patterns A and B under Other, see “EXPLANATION FOR DRIVING PATTERNS FOR “MISFIRE <EXHAUST QUALITY DETERIORATION>”, “FUEL INJECTION SYSTEM”.

*1: Clear timing is at the moment OK is detected.

*2: Clear timing is when the same malfunction is detected in the 2nd trip.

Relationship Between MIL, DTC, 1st Trip DTC and Driving Patterns for “Misfire <Exhaust Quality Deterioration>”, “Fuel Injection System”

ON BOARD DIAGNOSTIC (OBD) SYSTEM

< SYSTEM DESCRIPTION >

[MR18DE]

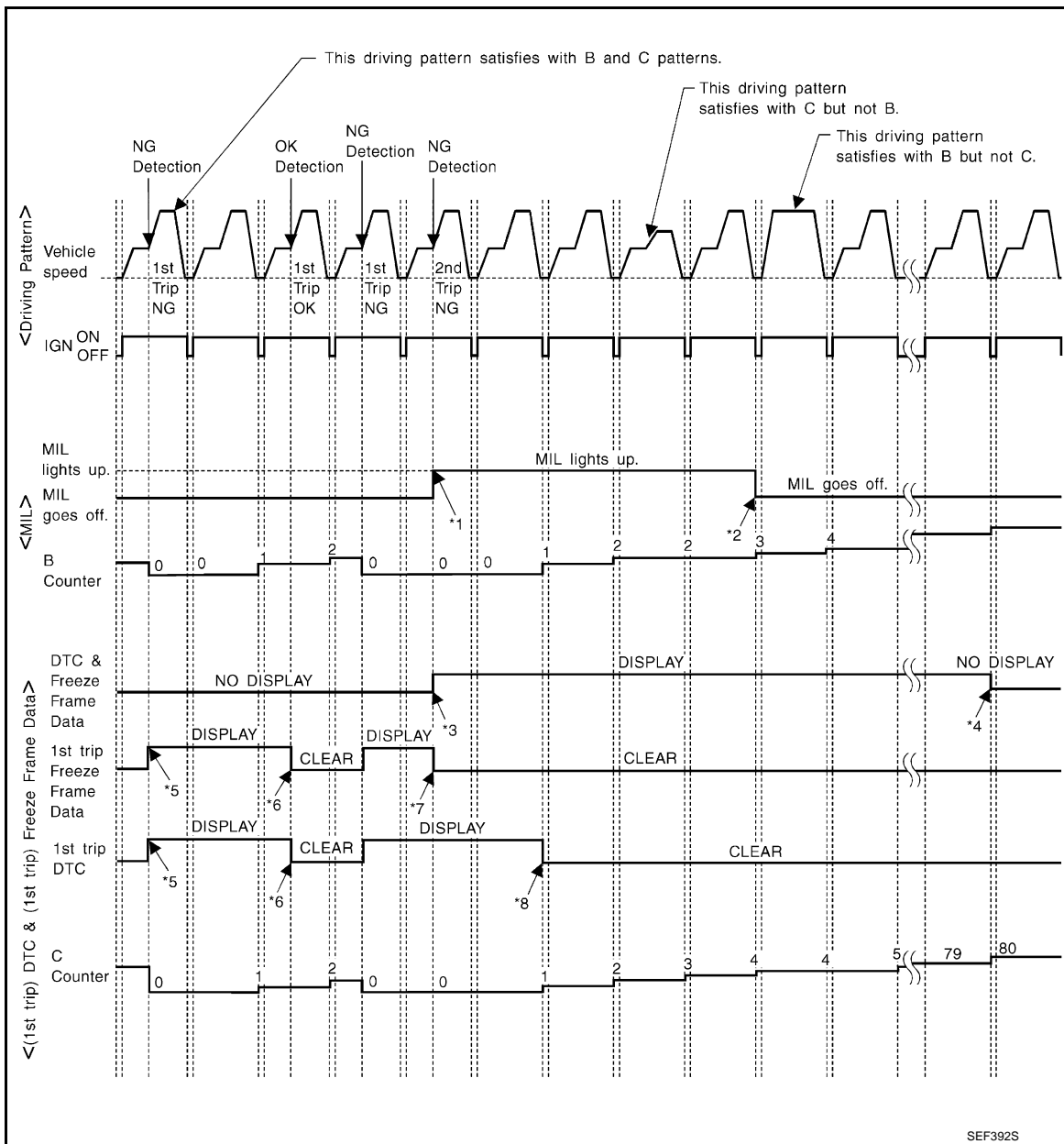

*1: When the same malfunction is detected in two consecutive trips, MIL will light up.

*2: MIL will go off after vehicle is driven 3 times (pattern B) without any malfunctions.

*3: When the same malfunction is detected in two consecutive trips, the DTC and the freeze frame data will be stored in ECM.

*4: The DTC and the freeze frame data will not be displayed any longer after vehicle is driven 80 times (pattern C) without the same malfunction. (The DTC and the freeze frame data still remain in ECM.)

*5: When a malfunction is detected for the first time, the 1st trip DTC and the 1st trip freeze frame data will be stored in ECM.

*6: The 1st trip DTC and the 1st trip freeze frame data will be cleared at the moment OK is detected.

*7: When the same malfunction is detected in the 2nd trip, the 1st trip freeze frame data will be cleared.

*8: 1st trip DTC will be cleared when vehicle is driven once (pattern C) without the same malfunction after DTC is stored in ECM.

Explanation for Driving Patterns for "Misfire <Exhaust Quality Deterioration>", "Fuel Injection System"

<Driving Pattern B>

Driving pattern B means the vehicle operation as per the following:

All components and systems should be monitored at least once by the OBD system.

ON BOARD DIAGNOSTIC (OBD) SYSTEM

[MR18DE]

< SYSTEM DESCRIPTION >

- The B counter will be cleared when the malfunction is detected once regardless of the driving pattern.
- The B counter will be counted up when driving pattern B is satisfied without any malfunction.
- The MIL will go off when the B counter reaches 3. (*2 in "OBD SYSTEM OPERATION CHART")

<Driving Pattern C>

Driving pattern C means the vehicle operation as per the following:

The following conditions should be satisfied at the same time:

Engine speed: (Engine speed in the freeze frame data) \pm 375 rpm

Calculated load value: (Calculated load value in the freeze frame data) \times (1 \pm 0.1) [%]

Engine coolant temperature (T) condition:

- When the freeze frame data shows lower than 70°C (158°F), T should be lower than 70°C (158°F).
- When the freeze frame data shows higher than or equal to 70°C (158°F), T should be higher than or equal to 70°C (158°F).

Example:

If the stored freeze frame data is as per the following:

Engine speed: 850 rpm, Calculated load value: 30%, Engine coolant temperature: 80°C (176°F)

To be satisfied with driving pattern C, the vehicle should run under the following conditions:

Engine speed: 475 - 1,225 rpm, Calculated load value: 27 - 33%, Engine coolant temperature: more than 70°C (158°F)

- The C counter will be cleared when the malfunction is detected regardless of vehicle conditions above.
- The C counter will be counted up when vehicle conditions above is satisfied without the same malfunction.
- The DTC will not be displayed after C counter reaches 80.
- The 1st trip DTC will be cleared when C counter is counted once without the same malfunction after DTC is stored in ECM.

Relationship Between MIL, DTC, 1st Trip DTC and Driving Patterns Except For "Misfire <Exhaust Quality Deterioration>", "Fuel Injection System"

ON BOARD DIAGNOSTIC (OBD) SYSTEM

< SYSTEM DESCRIPTION >

[MR18DE]

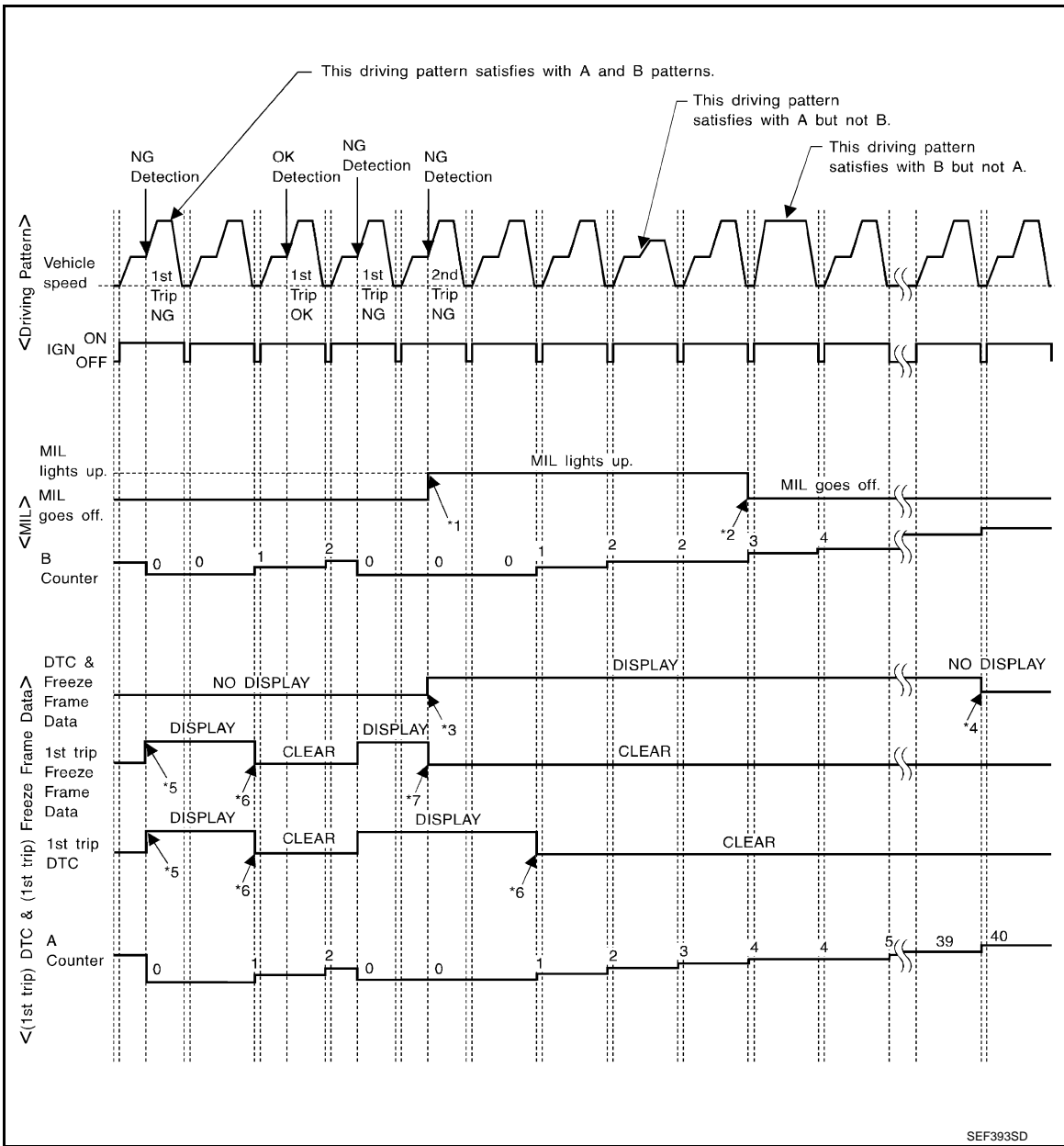

*1: When the same malfunction is detected in two consecutive trips, MIL will light up.

*2: MIL will go off after vehicle is driven 3 times (pattern B) without any malfunctions.

*3: When the same malfunction is detected in two consecutive trips, the DTC and the freeze frame data will be stored in ECM.

*4: The DTC and the freeze frame data will not be displayed any longer after vehicle is driven 40 times (pattern A) without the same malfunction. (The DTC and the freeze frame data still remain in ECM.)

*5: When a malfunction is detected for the first time, the 1st trip DTC and the 1st trip freeze frame data will be stored in ECM.

*6: 1st trip DTC will be cleared after vehicle is driven once (pattern B) without the same malfunction.

*7: When the same malfunction is detected in the 2nd trip, the 1st trip freeze frame data will be cleared.

Explanation for Driving Patterns Except for "Misfire <Exhaust Quality Deterioration>", "Fuel Injection System"

ON BOARD DIAGNOSTIC (OBD) SYSTEM

[MR18DE]

< SYSTEM DESCRIPTION >

<Driving Pattern A>

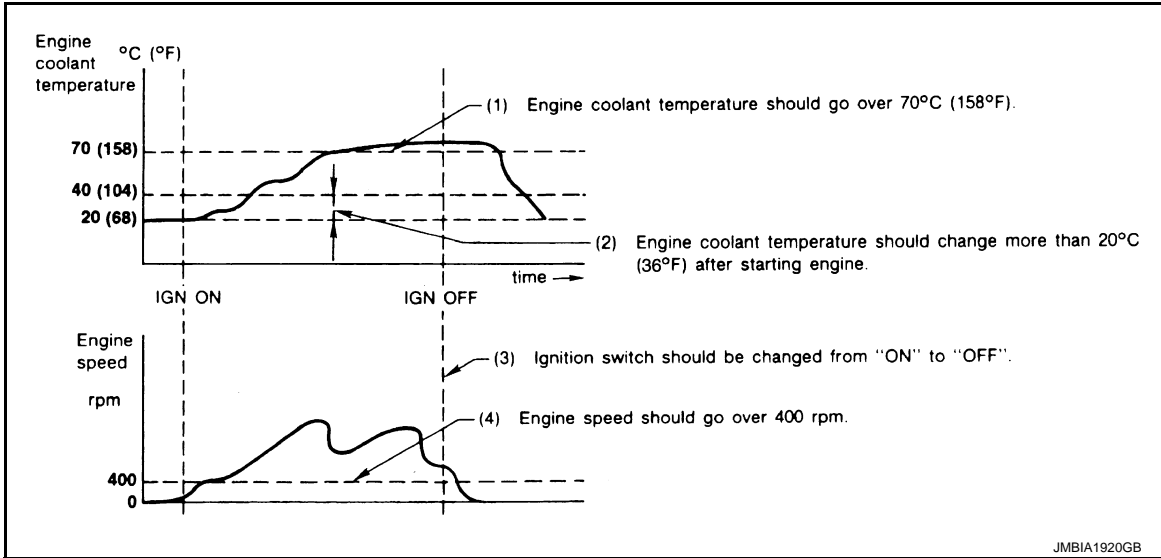

- The A counter will be cleared when the malfunction is detected regardless of (1) - (4).
- The A counter will be counted up when (1) - (4) are satisfied without the same malfunction.
- The DTC will not be displayed after the A counter reaches 40.

<Driving Pattern B>

Driving pattern B means the vehicle operation as per the following:

All components and systems should be monitored at least once by the OBD system.

- The B counter will be cleared when the malfunction is detected once regardless of the driving pattern.
- The B counter will be counted up when driving pattern B is satisfied without any malfunctions.
- The MIL will go off when the B counter reaches 3 (*2 in OBD SYSTEM OPERATION CHART).

CONSULT-III Function

INFOID:000000004833189

FUNCTION

Diagnostic test mode	Function
Work support	This mode enables a technician to adjust some devices faster and more accurately by following the indications on the CONSULT-III screen.
Self diagnostic result	Self-diagnostic results such as 1st trip DTC, DTCs and 1st trip freeze frame data or freeze frame data can be read and erased quickly.*
Data monitor	Input/Output data in the ECM can be read.
Active test	Diagnostic Test Mode in which CONSULT-III drives some actuators apart from the ECMs and also shifts some parameters in a specified range.
DTC & SRT confirmation	The status of system monitoring tests and the self-diagnosis status/results can be confirmed.
Function test	This mode is used to inform customers when their vehicle condition requires periodic maintenance.
ECU Identification	ECM part number can be read.

*: The following emission-related diagnostic information is cleared when the ECM memory is erased.

- Diagnostic trouble codes
- 1st trip diagnostic trouble codes
- Freeze frame data
- 1st trip freeze frame data
- System readiness test (SRT) codes
- Test values

ENGINE CONTROL COMPONENT PARTS/CONTROL SYSTEMS APPLICATION

ON BOARD DIAGNOSTIC (OBD) SYSTEM

< SYSTEM DESCRIPTION >

[MR18DE]

Item		DIAGNOSTIC TEST MODE									
		Work Support	Self Diagnostic Result		Data Monitor	Active Test	DTC & SRT CONFIRMATION				
			DTC*1	FREEZE FRAME DATA*2			SRT STATUS	DTC WORK SUPPORT			
ENGINE CONTROL COMPONENT PARTS	INPUT	Crankshaft position sensor (POS)		×	×	×					
	Camshaft position sensor (PHASE)		×	×	×						
	Mass air flow sensor		×		×						
	Engine coolant temperature sensor		×	×	×	×					
	Air fuel ratio (A/F) sensor 1		×		×		×	×			
	Heated oxygen sensor 2		×		×		×	×			
	Vehicle speed signal		×	×	×						
	Accelerator pedal position sensor		×		×						
	Throttle position sensor		×	×	×						
	Fuel tank temperature sensor		×		×	×					
	EVAP control system pressure sensor		×		×						
	Intake air temperature sensor		×	×	×						
	Knock sensor		×								
	Refrigerant pressure sensor				×						
	Closed throttle position switch (accelerator pedal position sensor signal)				×						
	Air conditioner ON signal				×						
	Park/neutral position (PNP) switch (M/T models)		×		×						
	Transmission range switch (CVT models)		×		×						
	Stop lamp switch		×		×						
	Power steering operation signal				×						
	Battery voltage				×						
	Load signal				×						
	Primary speed sensor		×		×						
Fuel level sensor signal		×		×							
Battery current sensor		×		×							
ASCD steering switch		×		×							
ASCD brake switch		×		×							
ASCD clutch switch		×		×							

A
EC
C
D
E
F
G
H
I
J
K
L
M
N
O
P

ON BOARD DIAGNOSTIC (OBD) SYSTEM

< SYSTEM DESCRIPTION >

[MR18DE]

Item		DIAGNOSTIC TEST MODE						
		Work Support	Self Diagnostic Result		Data Monitor	Active Test	DTC & SRT CONFIRMATION	
			DTC*1	FREEZE FRAME DATA*2			SRT STATUS	DTC WORK SUPPORT
ENGINE CONTROL COMPONENT PARTS OUTPUT	Fuel injector				×	×		
	Power transistor (Ignition timing)				×	×		
	Throttle control motor relay		×		×			
	Throttle control motor		×					
	EVAP canister purge volume control solenoid valve		×		×	×		×
	Air conditioner relay				×			
	Fuel pump relay	×			×	×		
	Cooling fan relay		×		×	×		
	Air fuel ratio (A/F) sensor 1 heater		×		×		×*3	
	Heated oxygen sensor 2 heater		×		×		×*3	
	EVAP canister vent control valve	×	×		×	×		
	Intake valve timing control solenoid valve		×		×	×		
	Alternator				×	×		
	Calculated load value			×	×			

X: Applicable

*1: This item includes 1st trip DTCs.

*2: This mode includes 1st trip freeze frame data or freeze frame data. The items appear on CONSULT-III screen in freeze frame data mode only if a 1st trip DTC or DTC is detected. For details, refer to [EC-85, "Diagnosis Description"](#).

*3: Always "CMLPT" is displayed.

WORK SUPPORT MODE

Work Item

WORK ITEM	CONDITION	USAGE
FUEL PRESSURE RELEASE	<ul style="list-style-type: none"> FUEL PUMP WILL STOP BY TOUCHING "START" DURING IDLING. CRANK A FEW TIMES AFTER ENGINE STALLS. 	When releasing fuel pressure from fuel line
IDLE AIR VOL LEARN	<ul style="list-style-type: none"> THE IDLE AIR VOLUME THAT KEEPS THE ENGINE WITHIN THE SPECIFIED RANGE IS MEMORIZED IN ECM. 	When learning the idle air volume
SELF-LEARNING CONT	<ul style="list-style-type: none"> THE COEFFICIENT OF SELF-LEARNING CONTROL MIXTURE RATIO RETURNS TO THE ORIGINAL COEFFICIENT. 	When clearing mixture ratio self-learning value

ON BOARD DIAGNOSTIC (OBD) SYSTEM

< SYSTEM DESCRIPTION >

[MR18DE]

WORK ITEM	CONDITION	USAGE
EVAP SYSTEM CLOSE	CLOSE THE EVAP CANISTER VENT CONTROL VALVE IN ORDER TO MAKE EVAP SYSTEM CLOSE UNDER THE FOLLOWING CONDITIONS. <ul style="list-style-type: none"> • IGN SW ON • ENGINE NOT RUNNING • AMBIENT TEMPERATURE IS ABOVE 0°C (32°F). • NO VACUUM AND NO HIGH PRESSURE IN EVAP SYSTEM • FUEL TANK TEMP. IS MORE THAN 0°C (32°F). • WITHIN 10 MINUTES AFTER STARTING "EVAP SYSTEM CLOSE" • WHEN TRYING TO EXECUTE "EVAP SYSTEM CLOSE" UNDER THE CONDITION EXCEPT ABOVE, CONSULT-III WILL DISCONTINUE IT AND DISPLAY APPROPRIATE INSTRUCTION. NOTE: WHEN STARTING ENGINE, CONSULT-III MAY DISPLAY "BATTERY VOLTAGE IS LOW. CHARGE BATTERY", EVEN IN USING CHARGED BATTERY.	When detecting EVAP vapor leak point of EVAP system
VIN REGISTRATION	<ul style="list-style-type: none"> • IN THIS MODE, VIN IS REGISTERED IN ECM. 	When registering VIN in ECM
TARGET IDLE RPM ADJ*	<ul style="list-style-type: none"> • IDLE CONDITION 	When setting target idle speed
TARGET IGN TIM ADJ*	<ul style="list-style-type: none"> • IDLE CONDITION 	When adjusting target ignition timing

*: This function is not necessary in the usual service procedure.

SELF DIAGNOSTIC RESULT MODE

Self Diagnostic Item

Regarding items of DTC and 1st trip DTC, refer to [EC-448, "DTC Index".](#))

Freeze Frame Data and 1st Trip Freeze Frame Data

Freeze frame data item*	Description
DTC	<ul style="list-style-type: none"> • The engine control component part/control system has a trouble code that is displayed as DTC. (Refer to EC-448, "DTC Index".)
FUEL SYS-B1	<ul style="list-style-type: none"> • "Fuel injection system status" at the moment a malfunction is detected is displayed. • One mode in the following is displayed. Mode2: Open loop due to detected system malfunction Mode3: Open loop due to driving conditions (power enrichment, deceleration enrichment) Mode4: Closed loop - using oxygen sensor(s) as feedback for fuel control Mode5: Open loop - has not yet satisfied condition to go to closed loop
CAL/LD VALUE [%]	<ul style="list-style-type: none"> • The calculated load value at the moment a malfunction is detected is displayed.
COOLANT TEMP [°C] or [°F]	<ul style="list-style-type: none"> • The engine coolant temperature at the moment a malfunction is detected is displayed.
L-FUEL TRM-B1 [%]	<ul style="list-style-type: none"> • "Long-term fuel trim" at the moment a malfunction is detected is displayed. • The long-term fuel trim indicates much more gradual feedback compensation to the base fuel schedule than short-term fuel trim.
S-FUEL TRM-B1 [%]	<ul style="list-style-type: none"> • "Short-term fuel trim" at the moment a malfunction is detected is displayed. • The short-term fuel trim indicates dynamic or instantaneous feedback compensation to the base fuel schedule.
ENGINE SPEED [rpm]	<ul style="list-style-type: none"> • The engine speed at the moment a malfunction is detected is displayed.
VEHICL SPEED [km/h] or [mph]	<ul style="list-style-type: none"> • The vehicle speed at the moment a malfunction is detected is displayed.
ABSOL TH-P/S [%]	<ul style="list-style-type: none"> • The throttle valve opening angle at the moment a malfunction is detected is displayed.
B/FUEL SCHDL [msec]	<ul style="list-style-type: none"> • The base fuel schedule at the moment a malfunction is detected is displayed.
INT/A TEMP SE [°C] or [°F]	<ul style="list-style-type: none"> • The intake air temperature at the moment a malfunction is detected is displayed.

ON BOARD DIAGNOSTIC (OBD) SYSTEM

[MR18DE]

< SYSTEM DESCRIPTION >

Freeze frame data item*	Description
FUEL SYS-B2	<ul style="list-style-type: none"> • These items displayed but are not applicable to this model.
L-FUEL TRM-B2 [%]	
S-FUEL TRM-B2 [%]	
INT MANI PRES [kPa]	
COMBUST CONDITION	

*: The items are the same as those of 1st trip freeze frame data.

DATA MONITOR MODE

Monitored Item

Monitored item	Unit	Description	Remarks
ENG SPEED	rpm	<ul style="list-style-type: none"> • Indicates the engine speed computed from the signal of the crankshaft position sensor (POS) and camshaft position sensor (PHASE). 	<ul style="list-style-type: none"> • Accuracy becomes poor if engine speed drops below the idle rpm. • If the signal is interrupted while the engine is running, an abnormal value may be indicated.
MAS A/F SE-B1	V	<ul style="list-style-type: none"> • The signal voltage of the mass air flow sensor is displayed. 	<ul style="list-style-type: none"> • When the engine is stopped, a certain value is indicated. • When engine is running specification range is indicated in "SPEC".
B/FUEL SCHDL	ms	<ul style="list-style-type: none"> • "Base fuel schedule" indicates the fuel injection pulse width programmed into ECM, prior to any learned on board correction. 	<ul style="list-style-type: none"> • When engine is running specification range is indicated in "SPEC".
A/F ALPHA-B1	%	<ul style="list-style-type: none"> • The mean value of the air-fuel ratio feedback correction factor per cycle is indicated. 	<ul style="list-style-type: none"> • When the engine is stopped, a certain value is indicated. • This data also includes the data for the air-fuel ratio learning control. • When engine is running specification range is indicated in "SPEC".
COOLAN TEMP/S	°C or °F	<ul style="list-style-type: none"> • The engine coolant temperature (determined by the signal voltage of the engine coolant temperature sensor) is displayed. 	<ul style="list-style-type: none"> • When the engine coolant temperature sensor is open or short-circuited, ECM enters fail-safe mode. The engine coolant temperature determined by the ECM is displayed.
A/F SEN1 (B1)	V	<ul style="list-style-type: none"> • The A/F signal computed from the input signal of the air fuel ratio (A/F) sensor 1 is displayed. 	
HO2S2 (B1)	V	<ul style="list-style-type: none"> • The signal voltage of the heated oxygen sensor 2 is displayed. 	
HO2S2 MNTR(B1)	RICH/LEAN	<ul style="list-style-type: none"> • Display of heated oxygen sensor 2 signal: RICH: means the amount of oxygen after three way catalyst is relatively small. LEAN: means the amount of oxygen after three way catalyst is relatively large. 	<ul style="list-style-type: none"> • When the engine is stopped, a certain value is indicated.
VHCL SPEED SE	km/h or mph	<ul style="list-style-type: none"> • The vehicle speed computed from the vehicle speed signal sent from combination meter is displayed. 	
BATTERY VOLT	V	<ul style="list-style-type: none"> • The power supply voltage of ECM is displayed. 	
ACCEL SEN 1	V	<ul style="list-style-type: none"> • The accelerator pedal position sensor signal voltage is displayed. 	<ul style="list-style-type: none"> • ACCEL SEN 2 signal is converted by ECM internally. Thus, it differs from ECM terminal voltage signal.
ACCEL SEN 2			
TP SEN 1-B1	V	<ul style="list-style-type: none"> • The throttle position sensor signal voltage is displayed. 	<ul style="list-style-type: none"> • TP SEN 2-B1 signal is converted by ECM internally. Thus, it differs from ECM terminal voltage signal.
TP SEN 2-B1			
FUEL T/TMP SE	°C or °F	<ul style="list-style-type: none"> • The fuel temperature (determined by the signal voltage of the fuel tank temperature sensor) is displayed. 	

ON BOARD DIAGNOSTIC (OBD) SYSTEM

< SYSTEM DESCRIPTION >

[MR18DE]

Monitored item	Unit	Description	Remarks
INT/A TEMP SE	°C or °F	<ul style="list-style-type: none"> The intake air temperature (determined by the signal voltage of the intake air temperature sensor) is indicated. 	
EVAP SYS PRES	V	<ul style="list-style-type: none"> The signal voltage of EVAP control system pressure sensor is displayed. 	
FUEL LEVEL SE	V	<ul style="list-style-type: none"> The signal voltage of the fuel level sensor is displayed. 	
START SIGNAL	ON/OFF	<ul style="list-style-type: none"> Indicates start signal status [ON/OFF] computed by the ECM according to the signals of engine speed and battery voltage. 	<ul style="list-style-type: none"> After starting the engine, [OFF] is displayed regardless of the starter signal.
CLSD THL POS	ON/OFF	<ul style="list-style-type: none"> Indicates idle position [ON/OFF] computed by ECM according to the accelerator pedal position sensor signal. 	
AIR COND SIG	ON/OFF	<ul style="list-style-type: none"> Indicates [ON/OFF] condition of the air conditioner switch determined by the air conditioner ON signal. 	
P/N POSI SW	ON/OFF	<ul style="list-style-type: none"> Indicates [ON/OFF] condition from the park/neutral position (PNP) switch signal (M/T models) or Transmission range switch signal (CVT models). 	
PW/ST SIGNAL	ON/OFF	<ul style="list-style-type: none"> [ON/OFF] condition of the power steering system (determined by the signal sent from EPS control unit) is indicated. 	
LOAD SIGNAL	ON/OFF	<ul style="list-style-type: none"> Indicates [ON/OFF] condition from the electrical load signal. ON: Rear window defogger switch is ON and/or lighting switch is in 2nd position. OFF: Both rear window defogger switch and lighting switch are OFF. 	
IGNITION SW	ON/OFF	<ul style="list-style-type: none"> Indicates [ON/OFF] condition from ignition switch signal. 	
HEATER FAN SW	ON/OFF	<ul style="list-style-type: none"> Indicates [ON/OFF] condition from the heater fan switch signal. 	
BRAKE SW	ON/OFF	<ul style="list-style-type: none"> Indicates [ON/OFF] condition from the stop lamp switch signal. 	
INJ PULSE-B1	msec	<ul style="list-style-type: none"> Indicates the actual fuel injection pulse width compensated by ECM according to the input signals. 	<ul style="list-style-type: none"> When the engine is stopped, a certain computed value is indicated.
IGN TIMING	BTDC	<ul style="list-style-type: none"> Indicates the ignition timing computed by ECM according to the input signals. 	<ul style="list-style-type: none"> When the engine is stopped, a certain value is indicated.
CAL/LD VALUE	%	<ul style="list-style-type: none"> "Calculated load value" indicates the value of the current air flow divided by peak air flow. 	
MASS AIRFLOW	g-m/s	<ul style="list-style-type: none"> Indicates the mass air flow computed by ECM according to the signal voltage of the mass air flow sensor. 	
PURG VOL C/V	%	<ul style="list-style-type: none"> Indicates the EVAP canister purge volume control solenoid valve control value computed by the ECM according to the input signals. The opening becomes larger as the value increases. 	
INT/V TIM(B1)	°CA	<ul style="list-style-type: none"> Indicates [°CA] of intake camshaft advance angle. 	
INT/V SOL(B1)	%	<ul style="list-style-type: none"> The control value of the intake valve timing control solenoid valve (determined by ECM according to the input signals) is indicated. The advance angle becomes larger as the value increases. 	
AIR COND RLY	ON/OFF	<ul style="list-style-type: none"> The air conditioner relay control condition (determined by ECM according to the input signals) is indicated. 	
FUEL PUMP RLY	ON/OFF	<ul style="list-style-type: none"> Indicates the fuel pump relay control condition determined by ECM according to the input signals. 	

A

EC

C

D

E

F

G

H

I

J

K

L

M

N

O

P

ON BOARD DIAGNOSTIC (OBD) SYSTEM

[MR18DE]

< SYSTEM DESCRIPTION >

Monitored item	Unit	Description	Remarks
VENT CONT/V	ON/OFF	<ul style="list-style-type: none"> The control condition of the EVAP canister vent control valve (determined by ECM according to the input signals) is indicated. ON: Closed OFF: Open 	
THRTL RELAY	ON/OFF	<ul style="list-style-type: none"> Indicates the throttle control motor relay control condition determined by the ECM according to the input signals. 	
COOLING FAN	HI/LOW/ OFF	<ul style="list-style-type: none"> Indicates the condition of the cooling fan (determined by ECM according to the input signals). HI: High speed operation LOW: Low speed operation OFF: Stop 	
HO2S2 HTR (B1)	ON/OFF	<ul style="list-style-type: none"> Indicates [ON/OFF] condition of heated oxygen sensor 2 heater determined by ECM according to the input signals. 	
I/P PULLY SPD	rpm	<ul style="list-style-type: none"> Indicates the engine speed computed from the input speed sensor signal. 	
VEHICLE SPEED	km/h or mph	<ul style="list-style-type: none"> The vehicle speed computed from the vehicle speed signal sent from TCM is displayed. 	
IDL A/V LEARN	YET/CMPLT	<ul style="list-style-type: none"> Display the condition of Idle Air Volume Learning YET: Idle air volume learning has not been performed yet. CMPLT: Idle air volume learning has already been performed successfully. 	
TRVL AFTER MIL	km or mile	<ul style="list-style-type: none"> Distance traveled while MIL is activated. 	
A/F S1 HTR(B1)	%	<ul style="list-style-type: none"> Air fuel ratio (A/F) sensor 1 heater control value computed by ECM according to the input signals. The current flow to the heater becomes larger as the value increases. 	
AC PRESS SEN	V	<ul style="list-style-type: none"> The signal voltage from the refrigerant pressure sensor is displayed. 	
A/F ADJ-B1	—	<ul style="list-style-type: none"> Indicates the correction of factor stored in ECM. The factor is calculated from the difference between the target air-fuel ratio stored in ECM and the air-fuel ratio calculated from A/F sensor 1 signal. 	
BUT CUR SEN	mV	<ul style="list-style-type: none"> The signal voltage of battery current sensor is displayed. 	
ALT DUTY SIG	ON/OFF	<ul style="list-style-type: none"> The control condition of the power generation voltage variable control (determined by ECM according to the input signals) is indicated. ON: Power generation voltage variable control is active. OFF: Power generation voltage variable control is inactive. 	
ALT DUTY	%	<ul style="list-style-type: none"> Indicates the duty ratio of the power generation command value. The ratio is calculated by ECM based on the battery current sensor signal. 	
VHCL SPEED SE	km/h or mph	<ul style="list-style-type: none"> The vehicle speed computed from the vehicle speed signal sent from combination meter is displayed. 	
SET VHCL SPD	km/h or mph	<ul style="list-style-type: none"> The preset vehicle speed is displayed. 	
MAIN SW	ON/OFF	<ul style="list-style-type: none"> Indicates [ON/OFF] condition from MAIN switch signal. 	
CANCEL SW	ON/OFF	<ul style="list-style-type: none"> Indicates [ON/OFF] condition from CANCEL switch signal. 	
RESUME/ACC SW	ON/OFF	<ul style="list-style-type: none"> Indicates [ON/OFF] condition from RESUME/ACC switch signal. 	

ON BOARD DIAGNOSTIC (OBD) SYSTEM

[MR18DE]

< SYSTEM DESCRIPTION >

Monitored item	Unit	Description	Remarks
SET SW	ON/OFF	<ul style="list-style-type: none"> Indicates [ON/OFF] condition from SET switch signal. 	
BRAKE SW1	ON/OFF	<ul style="list-style-type: none"> Indicates [ON/OFF] condition from ASCD brake switch signal and ASCD clutch switch signal (M/T models). 	
BRAKE SW2	ON/OFF	<ul style="list-style-type: none"> Indicates [ON/OFF] condition of stop lamp switch signal. 	
VHCL SPD CUT	NON/CUT	<ul style="list-style-type: none"> Indicates the vehicle cruse condition. NON: Vehicle speed is maintained at the ASCD set speed. CUT: Vehicle speed decreased to excessively low compared with the ASCD set speed, and ASCD operation is cut off. 	
LO SPEED CUT	NON/CUT	<ul style="list-style-type: none"> Indicates the vehicle cruse condition. NON: Vehicle speed is maintained at the ASCD set speed. CUT: Vehicle speed decreased to excessively low and ASCD operation is cut off. 	
AT OD MONITOR	ON/OFF	<ul style="list-style-type: none"> Indicates [ON/OFF] condition of CVT O/D according to the input signal from the TCM. 	
AT OD CANCEL	ON/OFF	<ul style="list-style-type: none"> Indicates [ON/OFF] condition of CVT O/D cancel request signal from the TCM. 	
CRUISE LAMP	ON/OFF	<ul style="list-style-type: none"> Indicates [ON/OFF] condition of CRUISE lamp determined by the ECM according to the input signals. 	
SET LAMP	ON/OFF	<ul style="list-style-type: none"> Indicates [ON/OFF] condition of SET lamp determined by the ECM according to the input signals. 	

NOTE:

Any monitored item that does not match the vehicle being diagnosed is deleted from the display automatically.

ACTIVE TEST MODE

Test Item

TEST ITEM	CONDITION	JUDGMENT	CHECK ITEM (REMEDY)
FUEL INJECTION	<ul style="list-style-type: none"> Engine: Return to the original trouble condition Change the amount of fuel injection using CONSULT-III. 	If trouble symptom disappears, see CHECK ITEM.	<ul style="list-style-type: none"> Harness and connectors Fuel injector Air fuel ratio (A/F) sensor 1
IGNITION TIMING	<ul style="list-style-type: none"> Engine: Return to the original trouble condition Timing light: Set Retard the ignition timing using CONSULT-III. 	If trouble symptom disappears, see CHECK ITEM.	<ul style="list-style-type: none"> Perform Idle Air Volume Learning.
POWER BALANCE	<ul style="list-style-type: none"> Engine: After warming up, idle the engine. A/C switch OFF Selector lever: P or N position (CVT), Neutral position (M/T) Cut off each fuel injector signal one at a time using CONSULT-III. 	Engine runs rough or dies.	<ul style="list-style-type: none"> Harness and connectors Compression Fuel injector Power transistor Spark plug Ignition coil
COOLING FAN*	<ul style="list-style-type: none"> Ignition switch: ON Turn the cooling fan "LOW", "HI" and "OFF" using CONSULT-III. 	Cooling fan moves and stops.	<ul style="list-style-type: none"> Harness and connectors IPDM E/R (Cooling fan relay) Cooling fan motor
ENG COOLANT TEMP	<ul style="list-style-type: none"> Engine: Return to the original trouble condition Change the engine coolant temperature using CONSULT-III. 	If trouble symptom disappears, see CHECK ITEM.	<ul style="list-style-type: none"> Harness and connectors Engine coolant temperature sensor Fuel injector

ON BOARD DIAGNOSTIC (OBD) SYSTEM

[MR18DE]

< SYSTEM DESCRIPTION >

TEST ITEM	CONDITION	JUDGMENT	CHECK ITEM (REMEDY)
FUEL PUMP RELAY	<ul style="list-style-type: none"> Ignition switch: ON (Engine stopped) Turn the fuel pump relay "ON" and "OFF" using CONSULT-III and listen to operating sound. 	Fuel pump relay makes the operating sound.	<ul style="list-style-type: none"> Harness and connectors Fuel pump relay
PURG VOL CONT/V	<ul style="list-style-type: none"> Engine: After warming up, run engine at 1,500 rpm. Change the EVAP canister purge volume control solenoid valve opening percent using CONSULT-III. 	Engine speed changes according to the opening percent.	<ul style="list-style-type: none"> Harness and connectors Solenoid valve
FUEL/T TEMP SEN	<ul style="list-style-type: none"> Change the fuel tank temperature using CONSULT-III. 		
VENT CONTROL/V	<ul style="list-style-type: none"> Ignition switch: ON (Engine stopped) Turn solenoid valve "ON" and "OFF" using the CONSULT-III and listen to operating sound. 	Solenoid valve makes an operating sound.	<ul style="list-style-type: none"> Harness and connectors Solenoid valve
V/T ASSIGN ANGLE	<ul style="list-style-type: none"> Engine: Return to the original trouble condition Change intake valve timing using CONSULT-III. 	If trouble symptom disappears, see CHECK ITEM.	<ul style="list-style-type: none"> Harness and connectors Intake valve timing control solenoid valve
ALTERNATOR DUTY	<ul style="list-style-type: none"> Engine: idle. Change duty ratio using CONSULT-III. 	Battery voltage changes.	<ul style="list-style-type: none"> Harness and connectors IPDM E/R Alternator

*: Leaving cooling fan OFF with CONSULT-III while engine is running may cause the engine to overheat.

DTC & SRT CONFIRMATION MODE

SRT STATUS Mode

For details, refer to [EC-85, "Diagnosis Description"](#).

SRT WORK SUPPORT Mode

This mode enables a technician to drive a vehicle to set the SRT while monitoring the SRT status.

DTC WORK SUPPORT Mode

Test mode	Test item	Corresponding DTC No.	Reference page
EVAPORATIVE SYSTEM	EVP SML LEAK P0442/P1442*	P0442	EC-244
		P0455	EC-281
	EVP V/S LEAK P0456/P1456*	P0456	EC-287
	PURG VOL CN/V P1444	P0443	EC-251
	PURG FLOW P0441	P0441	EC-238
A/F SEN1	A/F SEN1 (B1) P1278/P1279	P0133	EC-175
	A/F SEN1 (B1) P1276	P0130	EC-165
HO2S2	HO2S2 (B1) P1146	P0138	EC-186
	HO2S2 (B1) P1147	P0137	EC-180
	HO2S2 (B1) P139	P0139	EC-194

*: DTC P1442, P1456 does not apply to this model but appears in DTC Work Support Mode screens.

Diagnosis Tool Function

INFOID:000000004833190

DESCRIPTION

ON BOARD DIAGNOSTIC (OBD) SYSTEM

[MR18DE]

< SYSTEM DESCRIPTION >

Generic Scan Tool (OBD II scan tool) complying with SAE J1978 has several functions explained below. ISO15765-4 is used as the protocol. The name "GST" or "Generic Scan Tool" is used in this service manual.

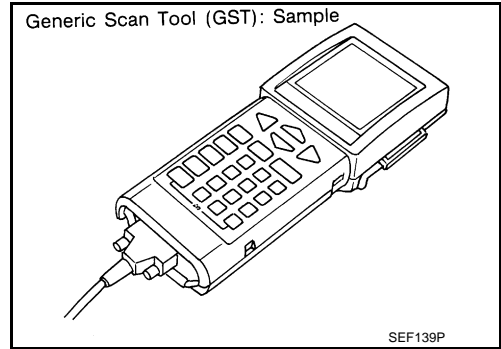

FUNCTION

Diagnostic Service		Function
Service \$01	READINESS TESTS	This diagnostic service gains access to current emission-related data values, including analog inputs and outputs, digital inputs and outputs, and system status information.
Service \$02	(FREEZE DATA)	This diagnostic service gains access to emission-related data value which were stored by ECM during the freeze frame. For details, refer to EC-448, "DTC Index" .
Service \$03	DTCs	This diagnostic service gains access to emission-related power train trouble codes which were stored by ECM.
Service \$04	CLEAR DIAG INFO	This diagnostic service can clear all emission-related diagnostic information. This includes: <ul style="list-style-type: none"> • Clear number of diagnostic trouble codes (Service \$01) • Clear diagnostic trouble codes (Service \$03) • Clear trouble code for freeze frame data (Service \$01) • Clear freeze frame data (Service \$02) • Reset status of system monitoring test (Service \$01) • Clear on board monitoring test results (Service \$06 and \$07)
Service \$06	(ON BOARD TESTS)	This diagnostic service accesses the results of on board diagnostic monitoring tests of specific components/systems that are not continuously monitored.
Service \$07	(ON BOARD TESTS)	This diagnostic service enables the off board test drive to obtain test results for emission-related powertrain components/systems that are continuously monitored during normal driving conditions.
Service \$08	—	This diagnostic service can close EVAP system in ignition switch ON position (Engine stopped). When this diagnostic service is performed, EVAP canister vent control valve can be closed. In the following conditions, this diagnostic service cannot function. <ul style="list-style-type: none"> • Low ambient temperature • Low battery voltage • Engine running • Ignition switch OFF • Low fuel temperature • Too much pressure is applied to EVAP system
Service \$09	(CALIBRATION ID)	This diagnostic service enables the off-board test device to request specific vehicle information such as Vehicle Identification Number (VIN) and Calibration IDs.

INSPECTION PROCEDURE

1. Turn ignition switch OFF.
2. Connect "GST" to data link connector (1), which is located under LH dash panel.
3. Turn ignition switch ON.

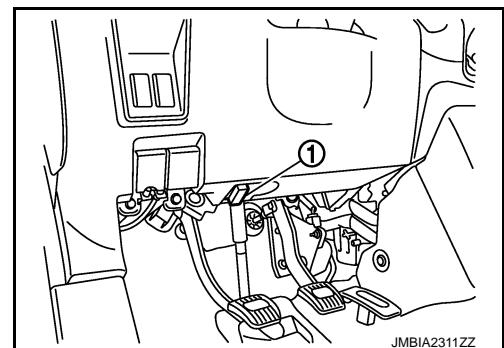

ON BOARD DIAGNOSTIC (OBD) SYSTEM

[MR18DE]

< SYSTEM DESCRIPTION >

4. Enter the program according to instruction on the screen or in the operation manual.
(*: Regarding GST screens in this section, sample screens are shown.)

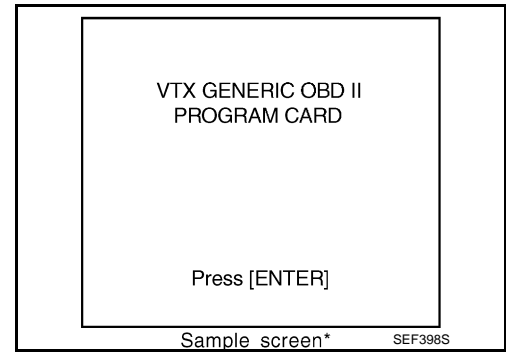

5. Perform each diagnostic mode according to each service procedure.
For further information, see the GST Operation Manual of the tool maker.

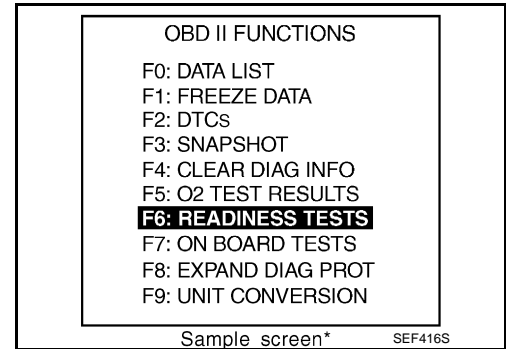

DTC/CIRCUIT DIAGNOSIS

TROUBLE DIAGNOSIS - SPECIFICATION VALUE

Description

INFOID:000000004833191

The specification (SP) value indicates the tolerance of the value that is displayed in "SPEC" of "DATA MONITOR" mode of CONSULT-III during normal operation of the Engine Control System. When the value in "SPEC" of "DATA MONITOR" mode is within the SP value, the Engine Control System is confirmed OK. When the value in "SPEC" of "DATA MONITOR" mode is NOT within the SP value, the Engine Control System may have one or more malfunctions.

The SP value is used to detect malfunctions that may affect the Engine Control System, but will not light the MIL.

The SP value will be displayed for the following three items:

- B/FUEL SCHDL (The fuel injection pulse width programmed into ECM prior to any learned on board correction)
- A/F ALPHA-B1 (The mean value of air-fuel ratio feedback correction factor per cycle)
- MAS A/F SE-B1 (The signal voltage of the mass air flow sensor)

Component Function Check

INFOID:000000004833192

1. START

Make sure that all of the following conditions are satisfied.

- Vehicle driven distance: More than 5,000 km (3,107 miles)
- Barometric pressure: 98.3 - 104.3 kPa (1.003 - 1.064 kg/cm², 14.25 - 15.12 psi)
- Atmospheric temperature: 20 - 30°C (68 - 86°F)
- Engine coolant temperature: 75 - 95°C (167 - 203°F)
- Transmission: Warmed-up
 - CVT models: After the engine is warmed up to normal operating temperature, drive vehicle until "FLUID TEMP SE" (CVT fluid temperature sensor signal) indicates more than 60°C (140°F).
 - M/T models: After the engine is warmed up to normal operating temperature, drive vehicle for 5 minutes.
- Electrical load: Not applied
 - Rear window defogger switch, air conditioner switch, lighting switch are OFF. Steering wheel is straight ahead.
- Engine speed: Idle

>> GO TO 2.

2. PERFORM "SPEC" OF "DATA MONITOR" MODE

With CONSULT-III

NOTE:

Perform "SPEC" in "DATA MONITOR" mode in maximum scale display.

1. Perform [EC-12. "BASIC INSPECTION : Special Repair Requirement"](#).
2. Select "B/FUEL SCHDL", "A/F ALPHA-B1" and "MAS A/F SE-B1" in "SPEC" of "DATA MONITOR" mode with CONSULT-III.
3. Make sure that monitor items are within the SP value.

Is the inspection result normal?

YES >> END

NO >> Go to [EC-110. "Diagnosis Procedure"](#).

TROUBLE DIAGNOSIS - SPECIFICATION VALUE

< DTC/CIRCUIT DIAGNOSIS >

[MR18DE]

Diagnosis Procedure

INFOID:000000004833193

OVERALL SEQUENCE

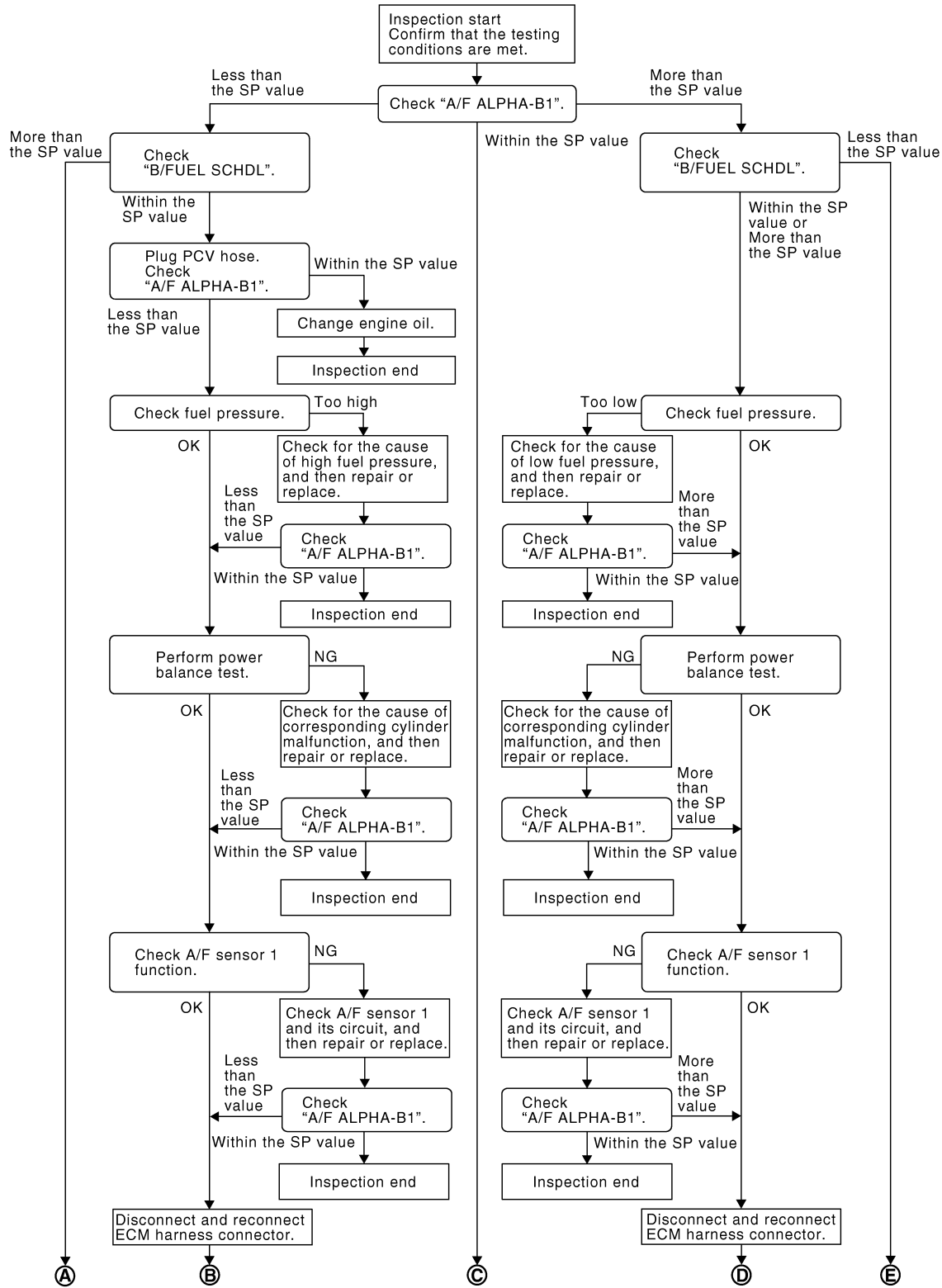

PBIB2318E

TROUBLE DIAGNOSIS - SPECIFICATION VALUE

< DTC/CIRCUIT DIAGNOSIS >

[MR18DE]

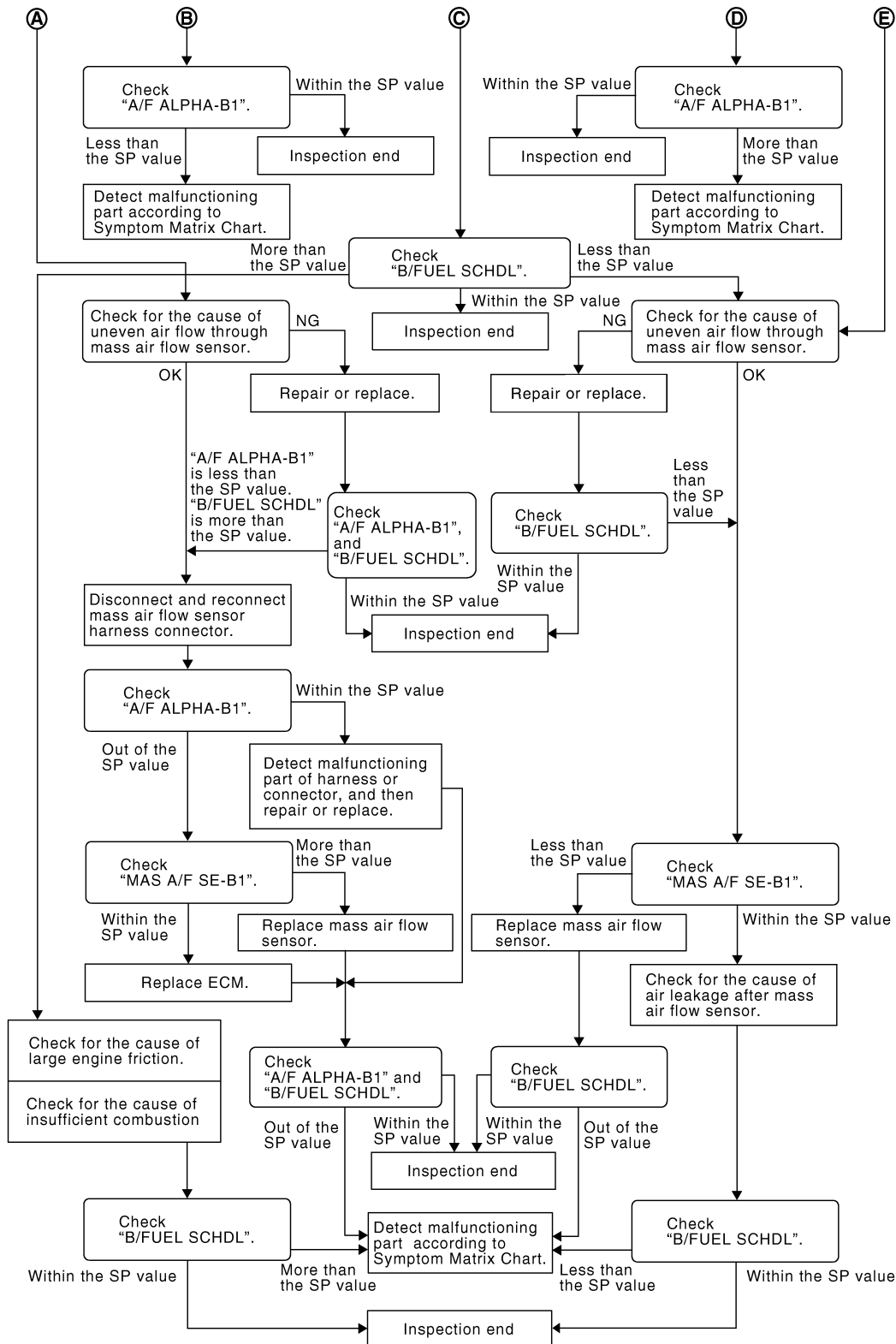

PBIB3213E

DETAILED PROCEDURE

1. CHECK "A/F ALPHA-B1"

④ With CONSULT-III

1. Start engine.
2. Confirm that the testing conditions are met. Refer to [EC-109, "Component Function Check"](#).
3. Select "A/F ALPHA-B1" in "SPEC" of "DATA MONITOR" mode, and make sure that the indication is within the SP value.

TROUBLE DIAGNOSIS - SPECIFICATION VALUE

[MR18DE]

< DTC/CIRCUIT DIAGNOSIS >

NOTE:

Check "A/F ALPHA-B1" for approximately 1 minute because it may fluctuate. It is NG if the indication is out of the SP value even a little.

Is the measurement value within the SP value?

- YES >> GO TO 17.
- NO-1 >> Less than the SP value: GO TO 2.
- NO-2 >> More than the SP value: GO TO 3.

2.CHECK "B/FUEL SCHDL"

Select "B/FUEL SCHDL" in "SPEC" of "DATA MONITOR" mode, and make sure that the indication is within the SP value.

Is the measurement value within the SP value?

- YES >> GO TO 4.
- NO >> More than the SP value: GO TO 19.

3.CHECK "B/FUEL SCHDL"

Select "B/FUEL SCHDL" in "SPEC" of "DATA MONITOR" mode, and make sure that the indication is within the SP value.

Is the measurement value within the SP value?

- YES >> GO TO 6.
- NO-1 >> More than the SP value: GO TO 6.
- NO-2 >> Less than the SP value: GO TO 25.

4.CHECK "A/F ALPHA-B1"

1. Stop the engine.
2. Disconnect PCV hose, and then plug it.
3. Start engine.
4. Select "A/F ALPHA-B1" in "SPEC" of "DATA MONITOR" mode, and make sure that the indication is within the SP value.

Is the measurement value within the SP value?

- YES >> GO TO 5.
- NO >> GO TO 6.

5.CHANGE ENGINE OIL

1. Stop the engine.
2. Change engine oil.

NOTE:

This symptom may occur when a large amount of gasoline is mixed with engine oil because of driving conditions (such as when engine oil temperature does not rise enough since a journey distance is too short during winter). The symptom will not be detected after changing engine oil or changing driving condition.

>> **INSPECTION END**

6.CHECK FUEL PRESSURE

Check fuel pressure. (Refer to [EC-471, "Inspection"](#).)

Is the inspection result normal?

- YES >> GO TO 9.
- NO-1 >> Fuel pressure is too high: Replace "fuel filter and fuel pump assembly" and then GO TO 8.
- NO-2 >> Fuel pressure is too low: GO TO 7.

7.DETECT MALFUNCTIONING PART

Check fuel hoses and fuel tubes for clogging

Is the inspection result normal?

- YES >> Replace "fuel filter and fuel pump assembly" and then GO TO 8.
- NO >> Repair or replace and then GO TO 8.

8.CHECK "A/F ALPHA-B1"

TROUBLE DIAGNOSIS - SPECIFICATION VALUE

[MR18DE]

< DTC/CIRCUIT DIAGNOSIS >

1. Start engine.
2. Select "A/F ALPHA-B1" in "SPEC" of "DATA MONITOR" mode, and make sure that the indication is within the SP value.

Is the measurement value within the SP value?

- YES >> INSPECTION END
NO >> GO TO 9.

9.PERFORM POWER BALANCE TEST

1. Perform "POWER BALANCE" in "ACTIVE TEST" mode.
2. Make sure that the each cylinder produces a momentary engine speed drop.

Is the inspection result normal?

- YES >> GO TO 12.
NO >> GO TO 10.

10.DETECT MALFUNCTIONING PART

Check the following.

1. Ignition coil and its circuit (Refer to [EC-401, "Component Function Check".](#))
2. Fuel injector and its circuit (Refer to [EC-395, "Component Function Check".](#))
3. Intake air leakage
4. Low compression pressure (Refer to [EM-21, "Inspection".](#))

Is the inspection result normal?

- YES >> Replace fuel injector and then GO TO 11.
NO >> Repair or replace malfunctioning part and then GO TO 11.

11.CHECK "A/F ALPHA-B1"

1. Start engine.
2. Select "A/F ALPHA-B1" in "SPEC" of "DATA MONITOR" mode, and make sure that the indication is within the SP value.

Is the measurement value within the SP value?

- YES >> INSPECTION END
NO >> GO TO 12.

12.CHECK A/F SENSOR 1 FUNCTION

Perform all DTC CONFIRMATION PROCEDURE related with A/F sensor 1.

- For DTC P0130, refer to [EC-165, "DTC Logic".](#)
- For DTC P0131, refer to [EC-169, "DTC Logic".](#)
- For DTC P0132, refer to [EC-172, "DTC Logic".](#)
- For DTC P0133, refer to [EC-175, "DTC Logic".](#)
- For DTC P2A00, refer to [EC-382, "DTC Logic".](#)

Is any DTC detected?

- YES >> GO TO 15.
NO >> GO TO 13.

13.CHECK A/F SENSOR 1 CIRCUIT

Perform DIAGNOSTIC PROCEDURE according to corresponding DTC.

>> GO TO 14.

14.CHECK "A/F ALPHA-B1"

1. Start engine.
2. Select "A/F ALPHA-B1" in "SPEC" of "DATA MONITOR" mode, and make sure that the indication is within the SP value.

Is the measurement value within the SP value?

- YES >> INSPECTION END
NO >> GO TO 15.

15.DISCONNECT AND RECONNECT ECM HARNESS CONNECTOR

1. Stop the engine.

TROUBLE DIAGNOSIS - SPECIFICATION VALUE

[MR18DE]

< DTC/CIRCUIT DIAGNOSIS >

2. Disconnect ECM harness connector.
3. Check pin terminal and connector for damage, and then reconnect it.

>> GO TO 16.

16.CHECK "A/F ALPHA-B1"

1. Start engine.
2. Select "A/F ALPHA-B1" in "SPEC" of "DATA MONITOR" mode, and make sure that the indication is within the SP value.

Is the measurement value within the SP value?

YES >> INSPECTION END

NO >> Detect malfunctioning part according to [EC-460, "Symptom Table"](#).

17.CHECK "B/FUEL SCHDL"

Select "B/FUEL SCHDL" in "SPEC" of "DATA MONITOR" mode, and make sure that the indication is within the SP value.

Is the measurement value within the SP value?

YES >> INSPECTION END

NO-1 >> More than the SP value: GO TO 18.

NO-2 >> Less than the SP value: GO TO 25.

18.DETECT MALFUNCTIONING PART

1. Check for the cause of large engine friction. Refer to the following.
 - Engine oil level is too high
 - Engine oil viscosity
 - Belt tension of power steering, alternator, A/C compressor, etc. is excessive
 - Noise from engine
 - Noise from transmission, etc.
2. Check for the cause of insufficient combustion. Refer to the following.
 - Valve clearance malfunction
 - Intake valve timing control function malfunction
 - Camshaft sprocket installation malfunction, etc.

>> Repair or replace malfunctioning part, and then GO TO 30.

19.CHECK INTAKE SYSTEM

Check for the cause of uneven air flow through mass air flow sensor. Refer to the following.

- Crushed air ducts
- Malfunctioning seal of air cleaner element
- Uneven dirt of air cleaner element
- Improper specification of intake air system

Is the inspection result normal?

YES >> GO TO 21.

NO >> Repair or replace malfunctioning part, and then GO TO 20.

20.CHECK "A/F ALPHA-B1", AND "B/FUEL SCHDL"

Select "A/F ALPHA-B1" and "B/FUEL SCHDL" in "SPEC" of "DATA MONITOR" mode, and make sure that each indication is within the SP value.

Is the measurement value within the SP value?

YES >> **INSPECTION END**

NO >> "B/FUEL SCHDL" is more, "A/F ALPHA-B1" is less than the SP value: GO TO 21.

21.DISCONNECT AND RECONNECT MASS AIR FLOW SENSOR HARNESS CONNECTOR

1. Stop the engine.
2. Disconnect mass air flow sensor harness connector.
3. Check pin terminal and connector for damage and then reconnect it again.

>> GO TO 22.

TROUBLE DIAGNOSIS - SPECIFICATION VALUE

[MR18DE]

< DTC/CIRCUIT DIAGNOSIS >

22.CHECK "A/F ALPHA-B1"

1. Start engine.
2. Select "A/F ALPHA-B1" in "SPEC" of "DATA MONITOR" mode, and make sure that the indication is within the SP value.

Is the measurement value within the SP value?

YES >> Detect malfunctioning part of mass air flow sensor circuit and repair it. Refer to [EC-136, "DTC Logic"](#). Then GO TO 29.

NO >> GO TO 23.

23.CHECK "MAS A/F SE-B1"

Select "MAS A/F SE-B1" in "SPEC" of "DATA MONITOR" mode, and make sure that the indication is within the SP value.

Is the measurement value within the SP value?

YES >> GO TO 24.

NO >> More than the SP value: Replace mass air flow sensor, and then GO TO 29.

24.REPLACE ECM

1. Replace ECM.
2. Perform [EC-15, "ADDITIONAL SERVICE WHEN REPLACING CONTROL UNIT : Special Repair Requirement"](#).

>> GO TO 29.

25.CHECK INTAKE SYSTEM

Check for the cause of uneven air flow through mass air flow sensor. Refer to the following.

- Crushed air ducts
- Malfunctioning seal of air cleaner element
- Uneven dirt of air cleaner element
- Improper specification of intake air system

Is the inspection result normal?

YES >> GO TO 27.

NO >> Repair or replace malfunctioning part, and then GO TO 26.

26.CHECK "B/FUEL SCHDL"

Select "B/FUEL SCHDL" in "SPEC" of "DATA MONITOR" mode, and make sure that the indication is within the SP value.

Is the measurement value within the SP value?

YES >> INSPECTION END

NO >> Less than the SP value: GO TO 27.

27.CHECK "MAS A/F SE-B1"

Select "MAS A/F SE-B1" in "SPEC" of "DATA MONITOR" mode, and make sure that the indication is within the SP value.

Is the measurement value within the SP value?

YES >> GO TO 28.

NO >> Less than the SP value: Replace mass air flow sensor, and then GO TO 30.

28.CHECK INTAKE SYSTEM

Check for the cause of air leak after the mass air flow sensor. Refer to the following.

- Disconnection, looseness, and cracks in air duct
- Looseness of oil filler cap
- Disconnection of oil level gauge
- Open stuck, breakage, hose disconnection, or cracks of PCV valve
- Disconnection or cracks of EVAP purge hose, open stuck of EVAP canister purge volume control solenoid valve
- Malfunctioning seal of rocker cover gasket
- Disconnection, looseness, or cracks of hoses, such as vacuum hose, connecting to intake air system parts

TROUBLE DIAGNOSIS - SPECIFICATION VALUE

[MR18DE]

< DTC/CIRCUIT DIAGNOSIS >

- Malfunctioning seal of intake air system, etc.

>> GO TO 30.

29.CHECK "A/F ALPHA-B1" AND "B/FUEL SCHDL"

Select "A/F ALPHA-B1" and "B/FUEL SCHDL" in "SPEC" of "DATA MONITOR" mode, and make sure that each indication is within the SP value.

Is the measurement value within the SP value?

YES >> INSPECTION END

NO >> Detect malfunctioning part according to [EC-460. "Symptom Table"](#).

30.CHECK "B/FUEL SCHDL"

Select "B/FUEL SCHDL" in "SPEC" of "DATA MONITOR" mode, and then make sure that the indication is within the SP value.

Is the measurement value within the SP value?

YES >> INSPECTION END

NO >> Detect malfunctioning part according to [EC-460. "Symptom Table"](#).

POWER SUPPLY AND GROUND CIRCUIT

Diagnosis Procedure

INFOID:000000004833197

1.CHECK GROUND CONNECTION

1. Turn ignition switch OFF.
2. Check ground connection E38. Refer to [GI-37, "Circuit Inspection"](#).

Is the inspection result normal?

- YES >> GO TO 2.
- NO >> Repair or replace ground connection.

2.CHECK ECM GROUND CIRCUIT FOR OPEN AND SHORT

1. Disconnect ECM harness connectors.
2. Check the continuity between ECM harness connector and ground.

ECM		Ground	Continuity
Connector	Terminal		
F7	10	Ground	Existed
	11		
E16	108		

3. Also check harness for short to power.

Is the inspection result normal?

- YES >> GO TO 4.
- NO >> GO TO 3.

3.DETECT MALFUNCTIONING PART

Check the following.

- Harness connectors F1, E8
- Harness for open or short between ECM and ground

>> Repair open circuit or short to power in harness or connectors.

4.CHECK ECM POWER SUPPLY CIRCUIT-I

1. Reconnect ECM harness connectors.
2. Turn ignition switch ON.
3. Check the voltage between ECM harness connector and ground.

ECM		Ground	Voltage
Connector	Terminal		
E16	93	Ground	Battery voltage

Is the inspection result normal?

- YES >> GO TO 6.
- NO >> GO TO 5.

5.DETECT MALFUNCTIONING PART

Check the following.

- 15 A fuse (No. 62)
- Harness for open or short between ECM and fuse

>> Repair open circuit or short to ground or short to power in harness or connectors.

6.CHECK ECM POWER SUPPLY CIRCUIT-II

1. Turn ignition switch OFF and wait at least 10 seconds.
2. Turn ignition switch ON and then OFF.

A
EC
C
D
E
F
G
H
I
J
K
L
M
N
O
P

POWER SUPPLY AND GROUND CIRCUIT

[MR18DE]

< DTC/CIRCUIT DIAGNOSIS >

3. Check the voltage between ECM harness connector and ground.

ECM		Ground	Voltage
Connector	Terminal		
E16	105	Ground	After turning ignition switch OFF, battery voltage will exist for a few seconds, then drop approximately 0 V.

Is the inspection result normal?

- YES >> GO TO 7.
NO >> GO TO 9.

7.CHECK ECM POWER SUPPLY CIRCUIT-III

1. Turn ignition switch ON.
2. Check the voltage between IPDM E/R harness connector and ground.

IPDM E/R		Ground	Voltage
Connector	Terminal		
E14	44	Ground	Battery voltage

Is the inspection result normal?

- YES >> GO TO 8.
NO >> Replace IPDM E/R. Refer to [PCS-35. "Removal and Installation"](#)(WITH I-key) or [PCS-65. "Removal and Installation"](#)(WITHOUT I-KEY) .

8.CHECK INTERMITTENT INCIDENT

Refer to [GI-34. "Intermittent Incident"](#).

>> INSPECTION END

9.CHECK ECM POWER SUPPLY CIRCUIT-IV

1. Turn ignition switch OFF and wait at least 10 seconds.
2. Check the voltage between ECM harness connector and ground.

ECM		Ground	Voltage
Connector	Terminal		
F7	32	Ground	Battery voltage

Is the inspection result normal?

- YES >> GO TO 13.
NO >> GO TO 10.

10.CHECK ECM POWER SUPPLY CIRCUIT-V

1. Disconnect ECM harness connector.
2. Disconnect IPDM E/R harness connector E14.
3. Check the continuity between ECM harness connector and IPDM E/R harness connector.

ECM		IPDM E/R		Continuity
Connector	Terminal	Connector	Terminal	
E7	32	E14	40	Existed

4. Also check harness for short to ground and short to power.

Is the inspection result normal?

- YES >> GO TO 12.
NO >> GO TO 11.

POWER SUPPLY AND GROUND CIRCUIT

< DTC/CIRCUIT DIAGNOSIS >

[MR18DE]

11. DETECT MALFUNCTIONING PART

Check the following.

- Harness connectors E8, F1
- Harness for open or short between ECM and IPDM E/R

>> Repair open circuit or short to ground or short to power in harness or connectors.

12. CHECK FUSE

1. Disconnect 20 A fuse (No. 43) from IPDM E/R.
2. Check 20 A fuse.

Is the inspection result normal?

YES >> GO TO 15.

NO >> Replace 20 A fuse.

13. CHECK ECM POWER SUPPLY CIRCUIT-VI

1. Disconnect ECM harness connector.
2. Disconnect IPDM E/R harness connector E14.
3. Check the continuity between ECM harness connector and IPDM E/R harness connector.

ECM		IPDM E/R		Continuity
Connector	Terminal	Connector	Terminal	
F16	105	E14	43	Existed

4. Also check harness for short to ground and short to power.

Is the inspection result normal?

YES >> GO TO 15.

NO >> GO TO 14.

14. DETECT MALFUNCTIONING PART

Check the following.

- Harness connectors E8, F1
- Harness for open or short between ECM and IPDM E/R

>> Repair open circuit or short to ground or short to power in harness or connectors.

15. CHECK INTERMITTENT INCIDENT

Refer to [GI-34. "Intermittent Incident"](#).

Is the inspection result normal?

YES >> Replace IPDM E/R. Refer to [PCS-35. "Removal and Installation"](#)(WITH I-key) or [PCS-65. "Removal and Installation"](#)(WITHOUT I-KEY) .

NO >> Repair open circuit or short to ground or short to power in harness or connectors.

U0101 CAN COMM CIRCUIT

< DTC/CIRCUIT DIAGNOSIS >

[MR18DE]

U0101 CAN COMM CIRCUIT

Description

INFOID:000000004833199

CAN (Controller Area Network) is a serial communication line for real time application. It is an on-vehicle multiplex communication line with high data communication speed and excellent error detection ability. Many electronic control units are equipped onto a vehicle, and each control unit shares information and links with other control units during operation (not independent). In CAN communication, control units are connected with 2 communication lines (CAN H line, CAN L line) allowing a high rate of information transmission with less wiring. Each control unit transmits/receives data but selectively reads required data only.

DTC Logic

INFOID:000000004833200

DTC DETECTION LOGIC

DTC No.	Trouble diagnosis name	DTC detecting condition	Possible cause
U0101	Lost communication with TCM	When ECM is not transmitting or receiving CAN communication signal of OBD (emission-related diagnosis) with TCM for 2 seconds or more.	<ul style="list-style-type: none">CAN communication line between TCM and ECM (CAN communication line is open or shorted)

DTC CONFIRMATION PROCEDURE

1. PERFORM DTC CONFIRMATION PROCEDURE

1. Turn ignition switch ON and wait at least 3 seconds.
2. Check DTC.

Is DTC detected?

- YES >> [EC-120, "Diagnosis Procedure"](#).
NO >> INSPECTION END

Diagnosis Procedure

INFOID:000000004833202

Go to [LAN-14, "Trouble Diagnosis Flow Chart"](#).

U0140 CAN COMM CIRCUIT

< DTC/CIRCUIT DIAGNOSIS >

[MR18DE]

U0140 CAN COMM CIRCUIT

Description

INFOID:000000005040122

CAN (Controller Area Network) is a serial communication line for real time application. It is an on-vehicle multiplex communication line with high data communication speed and excellent error detection ability. Many electronic control units are equipped onto a vehicle, and each control unit shares information and links with other control units during operation (not independent). In CAN communication, control units are connected with 2 communication lines (CAN H line, CAN L line) allowing a high rate of information transmission with less wiring. Each control unit transmits/receives data but selectively reads required data only.

DTC Logic

INFOID:000000005040123

DTC DETECTION LOGIC

DTC No.	Trouble diagnosis name	DTC detecting condition	Possible cause
U0140	Lost communication with BCM	When ECM is not transmitting or receiving CAN communication signal of OBD (emission related diagnosis) with BCM for 2 seconds or more.	<ul style="list-style-type: none">CAN communication line between BCM and ECM (CAN communication line is open or shorted)

DTC CONFIRMATION PROCEDURE

1. PERFORM DTC CONFIRMATION PROCEDURE

- Turn ignition switch ON and wait at least 3 seconds.
- Check DTC.

Is DTC detected?

YES >> [EC-121, "Diagnosis Procedure"](#).
NO >> INSPECTION END

Diagnosis Procedure

INFOID:000000005040124

Go to [LAN-14, "Trouble Diagnosis Flow Chart"](#).

U1001 CAN COMM CIRCUIT

< DTC/CIRCUIT DIAGNOSIS >

[MR18DE]

U1001 CAN COMM CIRCUIT

Description

INFOID:000000004833207

CAN (Controller Area Network) is a serial communication line for real time application. It is an on-vehicle multiplex communication line with high data communication speed and excellent error detection ability. Many electronic control units are equipped onto a vehicle, and each control unit shares information and links with other control units during operation (not independent). In CAN communication, control units are connected with 2 communication lines (CAN H line, CAN L line) allowing a high rate of information transmission with less wiring. Each control unit transmits/receives data but selectively reads required data only.

DTC Logic

INFOID:000000004833208

DTC DETECTION LOGIC

DTC No.	Trouble diagnosis name	DTC detecting condition	Possible cause
U1001	CAN communication line	When ECM is not transmitting or receiving CAN communication signal other than OBD (emission related diagnosis) for 2 seconds or more.	<ul style="list-style-type: none">Harness or connectors (CAN communication line is open or shorted)

DTC CONFIRMATION PROCEDURE

1. PERFORM DTC CONFIRMATION PROCEDURE

1. Turn ignition switch ON and wait at least 3 seconds.
2. Check 1st trip DTC.

Is 1st trip DTC detected?

- YES >> [EC-122, "Diagnosis Procedure"](#).
NO >> INSPECTION END

Diagnosis Procedure

INFOID:000000004833210

Go to [LAN-14, "Trouble Diagnosis Flow Chart"](#).

P0011 IVT CONTROL

DTC Logic

INFOID:000000004833211

DTC DETECTION LOGIC

NOTE:

If DTC P0011 is displayed with DTC P0075, first perform the trouble diagnosis for [EC-308. "DTC Logic"](#).

DTC No.	Trouble diagnosis name	DTC detecting condition	Possible cause
P0011	Intake valve timing control performance	There is a gap between angle of target and phase-control angle degree.	<ul style="list-style-type: none"> • Crankshaft position sensor (POS) • Camshaft position sensor (PHASE) • Intake valve control solenoid valve • Accumulation of debris to the signal pick-up portion of the camshaft • Timing chain installation • Foreign matter caught in the oil groove for intake valve timing control

DTC CONFIRMATION PROCEDURE

1. PRECONDITIONING

If DTC Confirmation Procedure has been previously conducted, always turn ignition switch OFF and wait at least 10 seconds before conducting the next test.

TESTING CONDITION:

Before performing the following procedure, confirm that battery voltage is between 10 V and 16 V at idle.

>> GO TO 2.

2. PERFORM DTC CONFIRMATION PROCEDURE-I

 **With CONSULT-III**

1. Turn ignition switch ON and select "DATA MONITOR" mode with CONSULT-III.
2. Start engine and warm it up to normal operating temperature.
3. Maintain the following conditions for at least 6 consecutive seconds. Hold the accelerator pedal as steady as possible.

ENG SPEED	500 - 2,000 rpm
COOLAN TEMP/S	More than 60°C (140°F)
B/FUEL SCHDL	More than 4.2 msec
Selector lever	P or N position (CVT) Neutral position (M/T)

4. Stop vehicle with engine running and let engine idle for 10 seconds.
5. Check 1st trip DTC.

 **With GST**

Follow the procedure "With CONSULT-III" above.

Is 1st trip DTC detected?

- YES >> Go to [EC-124. "Diagnosis Procedure"](#)
 NO >> GO TO 3.

3. PERFORM DTC CONFIRMATION PROCEDURE-II

 **With CONSULT-III**

1. Maintain the following conditions for at least 20 consecutive seconds.

ENG SPEED	1,200 - 3,175 rpm (A constant rotation is maintained.)
COOLAN TEMP/S	More than 65°C (149°F)

< DTC/CIRCUIT DIAGNOSIS >

Selector lever	1st or 2nd position
Driving location	Driving vehicle uphill (Increased engine load will help maintain the driving conditions required for this test.)

CAUTION:

Always drive at a safe speed.

2. Check 1st trip DTC.

With GST

Follow the procedure "With CONSULT-III" above.

Is 1st trip DTC detected?

- YES >> Go to [EC-124, "Diagnosis Procedure"](#)
- NO >> INSPECTION END

Diagnosis Procedure

INFOID:000000004833212

1. CHECK OIL PRESSURE WARNING LAMP

1. Start engine.
2. Check oil pressure warning lamp and confirm it is not illuminated.

Is oil pressure warning lamp illuminated?

- YES >> Go to [LU-13, "Inspection"](#).
- NO >> GO TO 2.

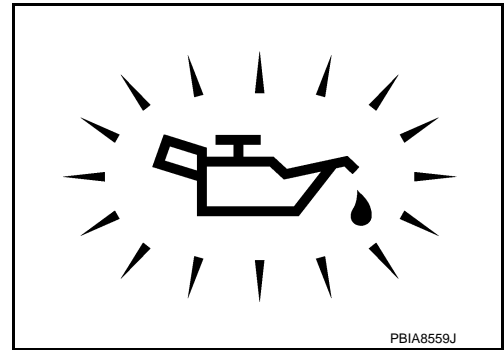

2. CHECK INTAKE VALVE TIMING CONTROL SOLENOID VALVE

Refer to [EC-125, "Component Inspection"](#).

Is the inspection result normal?

- YES >> GO TO 3.
- NO >> Replace intake valve timing control solenoid valve.

3. CHECK CRANKSHAFT POSITION SENSOR (POS)

Refer to [EC-228, "Component Inspection"](#).

Is the inspection result normal?

- YES >> GO TO 4.
- NO >> Replace crankshaft position sensor (POS).

4. CHECK CAMSHAFT POSITION SENSOR (PHASE)

Refer to [EC-231, "Component Inspection"](#).

Is the inspection result normal?

- YES >> GO TO 5.
- NO >> Replace camshaft position sensor (PHASE).

5. CHECK CAMSHAFT (INTAKE)

Check the following.

P0011 IVT CONTROL

[MR18DE]

< DTC/CIRCUIT DIAGNOSIS >

- Accumulation of debris to the signal plate of camshaft (1) rear end
- Chipping signal plate of camshaft rear end

Is the inspection result normal?

- YES >> GO TO 6.
NO >> Remove debris and clean the signal plate of camshaft rear end or replace camshaft.

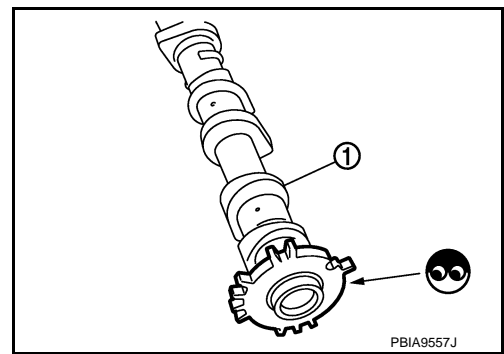

6.CHECK TIMING CHAIN INSTALLATION

Check service records for any recent repairs that may cause timing chain misaligned.

Are there any service records that may cause timing chain misaligned?

- YES >> Check timing chain installation. Refer to [EM-43, "Removal and Installation"](#).
NO >> GO TO 7.

7.CHECK LUBRICATION CIRCUIT

Refer to [LU-7, "Inspection"](#), "INSPECTION AFTER INSTALATION".

Is the inspection result normal?

- YES >> GO TO 8.
NO >> Clean lubrication line.

8.CHECK INTERMITTENT INCIDENT

Refer to [GI-34, "Intermittent Incident"](#).

>> INSPECTION END

Component Inspection

INFOID:000000004833213

1.CHECK INTAKE VALVE TIMING CONTROL SOLENOID VALVE-I

1. Turn ignition switch OFF.
2. Disconnect intake valve timing control solenoid valve harness connector.
3. Check resistance between intake valve timing control solenoid valve terminals as per the following.

Terminals	Resistance
1 and 2	6.7 - 7.7 Ω [at 20°C (68°F)]
1 or 2 and ground	$\infty \Omega$ (Continuity should not exist)

Is the inspection result normal?

- YES >> GO TO 2.
NO >> Replace intake valve timing control solenoid valve.

2.CHECK INTAKE VALVE TIMING CONTROL SOLENOID VALVE-II

1. Remove intake valve timing control solenoid valve.
2. Provide 12 V DC between intake valve timing control solenoid valve terminals 1 and 2, and then interrupt it. Make sure that the plunger moves as shown in the figure.

CAUTION:

Do not apply 12 V DC continuously for 5 seconds or more. Doing so may result in damage to the coil in intake valve timing control solenoid valve.

NOTE:

Always replace O-ring when intake valve timing control solenoid valve is removed.

Is the inspection result normal?

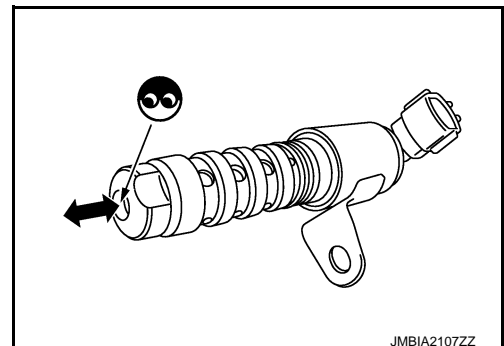

P0011 IVT CONTROL

[MR18DE]

< DTC/CIRCUIT DIAGNOSIS >

YES >> INSPECTION END

NO >> Replace intake valve timing control solenoid valve.

P0031, P0032 A/F SENSOR 1 HEATER

< DTC/CIRCUIT DIAGNOSIS >

[MR18DE]

P0031, P0032 A/F SENSOR 1 HEATER

Description

INFOID:000000004833214

SYSTEM DESCRIPTION

Sensor	Input signal to ECM	ECM function	Actuator
Camshaft position sensor (PHASE) Crankshaft position sensor (POS)	Engine speed	Air fuel ratio (A/F) sensor 1 heater control	Air fuel ratio (A/F) sensor 1 heater
Mass air flow sensor	Amount of intake air		

The ECM performs ON/OFF duty control of the A/F sensor 1 heater corresponding to the engine operating condition to keep the temperature of A/F sensor 1 element at the specified range.

DTC Logic

INFOID:000000004833215

DTC DETECTION LOGIC

DTC No.	Trouble diagnosis name	DTC detecting condition	Possible cause
P0031	Air fuel ratio (A/F) sensor 1 heater control circuit low	The current amperage in the A/F sensor 1 heater circuit is out of the normal range. (An excessively low voltage signal is sent to ECM through the A/F sensor 1 heater.)	<ul style="list-style-type: none">• Harness or connectors (The A/F sensor 1 heater circuit is open or shorted.)• A/F sensor 1 heater
P0032	Air fuel ratio (A/F) sensor 1 heater control circuit high	The current amperage in the A/F sensor 1 heater circuit is out of the normal range. (An excessively high voltage signal is sent to ECM through the A/F sensor 1 heater.)	<ul style="list-style-type: none">• Harness or connectors (The A/F sensor 1 heater circuit is shorted.)• A/F sensor 1 heater

DTC CONFIRMATION PROCEDURE

1. PRECONDITIONING

If DTC Confirmation Procedure has been previously conducted, always turn ignition switch OFF and wait at least 10 seconds before conducting the next test.

TESTING CONDITION:

Before performing the following procedure, confirm that battery voltage is more than between 11 V at idle.

>> GO TO 2.

2. PERFORM DTC CONFIRMATION PROCEDURE

1. Start engine and let it idle for at least 10 seconds.
2. Check 1st trip DTC.

Is 1st trip DTC detected?

YES >> Go to [EC-127, "Diagnosis Procedure"](#).

NO >> INSPECTION END

Diagnosis Procedure

INFOID:000000005151324

1. CHECK GROUND CONNECTION

1. Turn ignition switch OFF.
2. Check ground connection E38. Refer to Ground Inspection in [GI-37, "Circuit Inspection"](#).

Is the inspection result normal?

YES >> GO TO 2.

NO >> Repair or replace ground connection.

2. CHECK AIR FUEL RATIO (A/F) SENSOR 1 POWER SUPPLY CIRCUIT

1. Disconnect air fuel ratio (A/F) sensor 1 harness connector.
2. Turn ignition switch ON.

P0031, P0032 A/F SENSOR 1 HEATER

[MR18DE]

< DTC/CIRCUIT DIAGNOSIS >

3. Check the voltage between A/F sensor 1 harness connector and ground.

A/F sensor 1		Ground	Voltage
Connector	Terminal		
F50	4	Ground	Battery voltage

Is the inspection result normal?

YES >> GO TO 4.

NO >> GO TO 3.

3. DETECT MALFUNCTIONING PART

Check the following.

- Harness connectors E8, F1
- IPDM E/R harness connector E15
- 15 A fuse (No. 61)
- Harness for open or short between A/F sensor 1 and fuse

>> Repair or replace harness or connectors.

4. CHECK A/F SENSOR 1 HEATER OUTPUT SIGNAL CIRCUIT

1. Turn ignition switch OFF.
2. Disconnect ECM harness connector.
3. Check the continuity between A/F sensor 1 harness connector and ECM harness connector.

A/F sensor 1		ECM		Continuity
Connector	Terminal	Connector	Terminal	
F50	3	F7	8	Existed

4. Also check harness for short to ground and short to power.

Is the inspection result normal?

YES >> GO TO 5.

NO >> Repair open circuit, short to ground or short to power in harness or connectors.

5. CHECK A/F SENSOR 1 HEATER

Refer to [EC-129, "Component Inspection"](#).

Is the inspection result normal?

YES >> GO TO 7.

NO >> GO TO 6.

6. REPLACE AIR FUEL RATIO (A/F) SENSOR 1

Replace malfunctioning air fuel ratio (A/F) sensor 1.

CAUTION:

- Discard any A/F sensor which has been dropped from a height of more than 0.5 m (19.7 in) onto a hard surface such as a concrete floor; use a new one.
- Before installing new A/F sensor, clean exhaust system threads using Oxygen Sensor Thread Cleaner [commercial service tool (J-43897-18 or J-43897-12)] and approved Anti-seize Lubricant (commercial service tool).

>> INSPECTION END

7. CHECK INTERMITTENT INCIDENT

Perform [GI-34, "Intermittent Incident"](#).

>> Repair or replace.

P0031, P0032 A/F SENSOR 1 HEATER

< DTC/CIRCUIT DIAGNOSIS >

[MR18DE]

INFOID:000000004833218

Component Inspection

1. CHECK AIR FUEL RATIO (A/F) SENSOR 1

1. Turn ignition switch OFF.
2. Disconnect A/F sensor 1 harness connector.
3. Check resistance between A/F sensor 1 terminals as per the following.

Terminals	Resistance
3 and 4	1.8 - 2.44 Ω [at 20°C (68°F)]
3 and 1, 2	$\infty \Omega$
4 and 1, 2	(Continuity should not exist)

Is the inspection result normal?

- YES >> INSPECTION END
NO >> GO TO 2.

2. REPLACE AIR FUEL RATIO (A/F) SENSOR 1

Replace air fuel ratio (A/F) sensor 1.

CAUTION:

- Discard any sensor which has been dropped from a height of more than 0.5 m (19.7 in) onto a hard surface such as a concrete floor; use a new one.
- Before installing new sensor, clean exhaust system threads using Oxygen Sensor Thread Cleaner [commercial service tool (J-43897-18 or J43897-12)] and approved Anti-seize Lubricant (commercial service tool).

>> INSPECTION END

A
EC
C
D
E
F
G
H
I
J
K
L
M
N
O
P

P0037, P0038 HO2S2 HEATER

< DTC/CIRCUIT DIAGNOSIS >

[MR18DE]

P0037, P0038 HO2S2 HEATER

Description

INFOID:000000004833219

SYSTEM DESCRIPTION

Sensor	Input signal to ECM	ECM function	Actuator
Camshaft position sensor (PHASE) Crankshaft position sensor (POS)	Engine speed	Heated oxygen sensor 2 heater control	Heated oxygen sensor 2 heater
Engine coolant temperature sensor	Engine coolant temperature		
Mass air flow sensor	Amount of intake air		

The ECM performs ON/OFF control of the heated oxygen sensor 2 heater corresponding to the engine speed, amount of intake air and engine coolant temperature.

OPERATION

Engine speed	Heated oxygen sensor 2 heater
Above 3,600 rpm	OFF
Below 3,600 rpm after the following conditions are met. <ul style="list-style-type: none">• Engine: After warming up• Keeping the engine speed between 3,500 and 4,000 rpm for 1 minute and at idle for 1 minute under no load	ON

DTC Logic

INFOID:000000004833220

DTC DETECTION LOGIC

DTC No.	Trouble diagnosis name	DTC detecting condition	Possible cause
P0037	Heated oxygen sensor 2 heater control circuit low	The current amperage in the heated oxygen sensor 2 heater circuit is out of the normal range. (An excessively low voltage signal is sent to ECM through the heated oxygen sensor 2 heater.)	<ul style="list-style-type: none">• Harness or connectors (The heated oxygen sensor 2 heater circuit is open or shorted.)• Heated oxygen sensor 2 heater
P0038	Heated oxygen sensor 2 heater control circuit high	The current amperage in the heated oxygen sensor 2 heater circuit is out of the normal range. (An excessively high voltage signal is sent to ECM through the heated oxygen sensor 2 heater.)	<ul style="list-style-type: none">• Harness or connectors (The heated oxygen sensor 2 heater circuit is shorted.)• Heated oxygen sensor 2 heater

DTC CONFIRMATION PROCEDURE

1. PRECONDITIONING

If DTC Confirmation Procedure has been previously conducted, always turn ignition switch OFF and wait at least 10 seconds before conducting the next test.

TESTING CONDITION:

Before performing the following procedure, confirm that battery voltage is more than 11 V at idle.

>> GO TO 2.

2. PERFORM DTC CONFIRMATION PROCEDURE

With CONSULT-III

1. Turn ignition switch ON and select "DATA MONITOR" mode with CONSULT-III.
2. Start engine and warm it up to normal operating temperature.
3. Turn ignition switch OFF and wait at least 10 seconds.
4. Start engine and keep the engine speed between 3,500 and 4,000 rpm for at least 1 minute under no load.
5. Let engine idle for 1 minute.
6. Check 1st trip DTC.

With GST

Follow the procedure "With CONSULT-III" above.

Is 1st trip DTC detected?

P0037, P0038 HO2S2 HEATER

[MR18DE]

< DTC/CIRCUIT DIAGNOSIS >

- YES >> Go to [EC-131, "Diagnosis Procedure"](#).
NO >> INSPECTION END

A

Diagnosis Procedure

INFOID:000000004833222

1. CHECK GROUND CONNECTION

EC

1. Turn ignition switch OFF.
2. Check ground connection E38. Refer to [GI-37, "Circuit Inspection"](#).

C

Is the inspection result normal?

- YES >> GO TO 2.
NO >> Repair or replace ground connection.

D

2. CHECK HO2S2 POWER SUPPLY CIRCUIT

1. Disconnect heated oxygen sensor 2 (HO2S2) harness connector.
2. Turn ignition switch ON.
3. Check the voltage between HO2S2 harness connector and ground.

E

HO2S2		Ground	Voltage
Connector	Terminal		
F30	2	Ground	Battery voltage

F

Is the inspection result normal?

- YES >> GO TO 4.
NO >> GO TO 3.

G

H

3. DETECT MALFUNCTIONING PART

Check the following.

- Harness connectors E8, F1
- IPDM E/R connector E15
- 15 A fuse (No. 61)
- Harness for open or short between heated oxygen sensor 2 and fuse

I

J

>> Repair open circuit or short to ground or short to power in harness or connectors.

4. CHECK HO2S2 OUTPUT SIGNAL CIRCUIT FOR OPEN AND SHORT

K

1. Turn ignition switch OFF.
2. Disconnect ECM harness connector.
3. Check the continuity between HO2S2 harness connector and ECM harness connector.

L

HO2S2		ECM		Continuity
Connector	Terminal	Connector	Terminal	
F30	3	F7	5	Existed

M

4. Also check harness for short to ground and short to power.

N

Is the inspection result normal?

- YES >> GO TO 5.
NO >> Repair open circuit or short to ground or short to power in harness or connectors.

O

5. CHECK HEATED OXYGEN SENSOR 2 HEATER

Refer to [EC-132, "Component Inspection"](#).

P

Is the inspection result normal?

- YES >> GO TO 7.
NO >> GO TO 6.

6. REPLACE HEATED OXYGEN SENSOR 2

Replace heated oxygen sensor 2.

CAUTION:

P0037, P0038 HO2S2 HEATER

[MR18DE]

< DTC/CIRCUIT DIAGNOSIS >

- Discard any sensor which has been dropped from a height of more than 0.5 m (19.7 in) onto a hard surface such as a concrete floor; use a new one.
- Before installing new sensor, clean exhaust system threads using Oxygen Sensor Thread Cleaner [commercial service tool (J-43897-18 or J43897-12)] and approved Anti-seize Lubricant (commercial service tool).

>> INSPECTION END

7. CHECK INTERMITTENT INCIDENT

Refer to [GI-34, "Intermittent Incident"](#).

>> INSPECTION END

Component Inspection

INFOID:000000004833223

1. CHECK HEATED OXYGEN SENSOR 2 HEATER

1. Turn ignition switch OFF.
2. Disconnect heated oxygen sensor 2 (HO2S2) harness connector.
3. Check resistance between HO2S2 terminals as per the following.

Terminals	Resistance
2 and 3	3.3 - 4.4 Ω [at 25°C (77°F)]
1 and 2, 3, 4	$\infty \Omega$
4 and 1, 2, 3	(Continuity should not exist)

Is the inspection result normal?

- YES >> INSPECTION END
NO >> GO TO 2.

2. REPLACE HEATED OXYGEN SENSOR 2

Replace heated oxygen sensor 2.

CAUTION:

- Discard any sensor which has been dropped from a height of more than 0.5 m (19.7 in) onto a hard surface such as a concrete floor; use a new one.
- Before installing new sensor, clean exhaust system threads using Oxygen Sensor Thread Cleaner [commercial service tool (J-43897-18 or J43897-12)] and approved Anti-seize Lubricant (commercial service tool).

>> INSPECTION END

P0075 IVT CONTROL SOLENOID VALVE

< DTC/CIRCUIT DIAGNOSIS >

[MR18DE]

P0075 IVT CONTROL SOLENOID VALVE

Description

INFOID:000000004833224

Intake valve timing control solenoid valve is activated by ON/OFF pulse duty (ratio) signals from the ECM.

The intake valve timing control solenoid valve changes the oil amount and direction of flow through intake valve timing control unit or stops oil flow.

The longer pulse width advances valve angle.

The shorter pulse width retards valve angle.

When ON and OFF pulse widths become equal, the solenoid valve stops oil pressure flow to fix the intake valve angle at the control position.

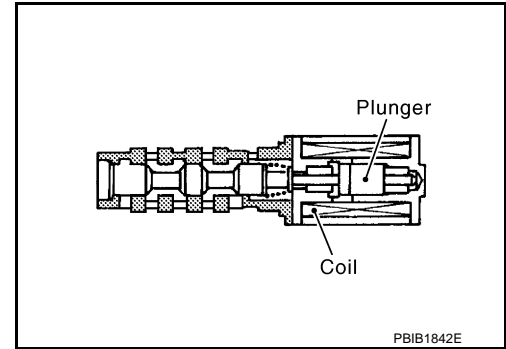

DTC Logic

INFOID:000000004833225

DTC DETECTION LOGIC

DTC No.	Trouble diagnosis name	DTC detecting condition	Possible cause
P0075	Intake valve timing control solenoid valve circuit	An improper voltage is sent to the ECM through intake valve timing control solenoid valve.	<ul style="list-style-type: none"> Harness or connectors (Intake valve timing control solenoid valve circuit is open or shorted.) Intake valve timing control solenoid valve

DTC CONFIRMATION PROCEDURE

1. PRECONDITIONING

If DTC Confirmation Procedure has been previously conducted, always turn ignition switch OFF and wait at least 10 seconds before conducting the next test.

>> GO TO2.

2. PERFORM DTC CONFIRMATION PROCEDURE

- Start engine and let it idle for 5 seconds.
- Check 1st trip DTC.

Is 1st trip DTC detected?

YES >> Go to [EC-133, "Diagnosis Procedure"](#).

NO >> INSPECTION END

Diagnosis Procedure

INFOID:000000004833227

1. CHECK INTAKE VALVE TIMING CONTROL SOLENOID VALVE POWER SUPPLY CIRCUIT

- Turn ignition switch OFF.
- Disconnect intake valve timing (IVT) control solenoid valve harness connector.
- Turn ignition switch ON.
- Check the voltage between intake valve timing control solenoid valve harness connector and ground.

IVT control solenoid valve		Ground	Voltage
Connector	Terminal		
F41	1	Ground	Battery voltage

Is the inspection result normal?

YES >> GO TO 3.

NO >> GO TO 2.

2. DETECT MALFUNCTIONING PART

P0075 IVT CONTROL SOLENOID VALVE

[MR18DE]

< DTC/CIRCUIT DIAGNOSIS >

Check the following.

- Harness connectors E8, F1
- IPDM E/R connector E14
- Harness for open or short between IVT control solenoid valve and IPDM E/R

>> Repair open circuit or short to ground or short to power in harness or connectors.

3.CHECK INTAKE VALVE TIMING CONTROL SOLENOID VALVE OUTPUT SIGNAL CIRCUIT FOR OPEN AND SHORT

1. Turn ignition switch OFF.
2. Disconnect ECM harness connector.
3. Check the continuity between IVT control solenoid valve harness connector and ECM harness connector.

IVT control solenoid valve		ECM		Continuity
Connector	Terminal	Connector	Terminal	
F41	2	F8	73	Existed

4. Also check harness for short to ground and short to power.

Is the inspection result normal?

YES >> GO TO 4.

NO >> Repair open circuit or short to ground or short to power in harness or connectors.

4.CHECK INTAKE VALVE TIMING CONTROL SOLENOID VALVE

Refer to [EC-134, "Component Inspection"](#).

Is the inspection result normal?

YES >> GO TO 5.

NO >> Replace intake valve timing control solenoid valve.

5.CHECK INTERMITTENT INCIDENT

Refer to [GI-34, "Intermittent Incident"](#).

>> INSPECTION END

Component Inspection

INFOID:000000004833228

1.CHECK INTAKE VALVE TIMING CONTROL SOLENOID VALVE-I

1. Turn ignition switch OFF.
2. Disconnect intake valve timing control solenoid valve harness connector.
3. Check resistance between intake valve timing control solenoid valve terminals as per the following.

Terminals	Resistance
1 and 2	6.7 - 7.7 Ω [at 20°C (68°F)]
1 or 2 and ground	$\infty \Omega$ (Continuity should not exist)

Is the inspection result normal?

YES >> GO TO 2.

NO >> Replace intake valve timing control solenoid valve.

2.CHECK INTAKE VALVE TIMING CONTROL SOLENOID VALVE-II

1. Remove intake valve timing control solenoid valve.

P0075 IVT CONTROL SOLENOID VALVE

[MR18DE]

< DTC/CIRCUIT DIAGNOSIS >

2. Provide 12 V DC between intake valve timing control solenoid valve terminals 1 and 2, and then interrupt it. Make sure that the plunger moves as shown in the figure.

CAUTION:

Do not apply 12 V DC continuously for 5 seconds or more. Doing so may result in damage to the coil in intake valve timing control solenoid valve.

NOTE:

Always replace O-ring when intake valve timing control solenoid valve is removed.

Is the inspection result normal?

YES >> INSPECTION END

NO >> Replace intake valve timing control solenoid valve.

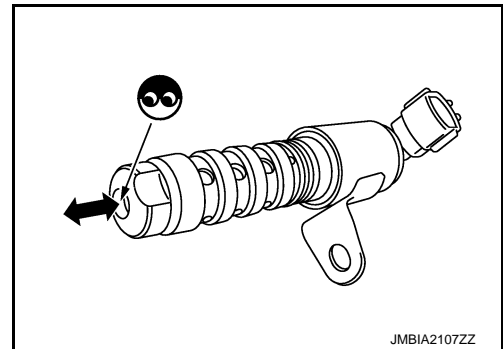

A

EC

C

D

E

F

G

H

I

J

K

L

M

N

O

P

P0101 MAF SENSOR

Description

INFOID:000000004833229

The mass air flow sensor (1) is placed in the stream of intake air. It measures the intake flow rate by measuring a part of the entire intake flow. The mass air flow sensor controls the temperature of the hot wire to a certain amount. The heat generated by the hot wire is reduced as the intake air flows around it. The more air, the greater the heat loss.

Therefore, the electric current supplied to hot wire is changed to maintain the temperature of the hot wire as air flow increases. The ECM detects the air flow by means of this current change.

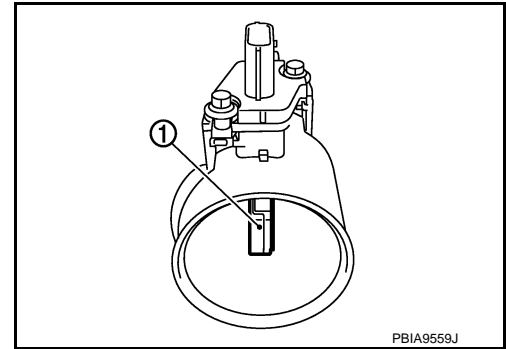

PBIA9559J

DTC Logic

INFOID:000000004833230

DTC DETECTION LOGIC

DTC No.	Trouble diagnosis name	DTC detecting condition		Possible cause
P0101	Mass air flow sensor circuit range/performance	A)	A high voltage from the sensor is sent to ECM under light load driving condition.	<ul style="list-style-type: none"> • Harness or connectors (The sensor circuit is open or shorted.) • Mass air flow sensor • EVAP control system pressure sensor
		B)	A low voltage from the sensor is sent to ECM under heavy load driving condition.	<ul style="list-style-type: none"> • Harness or connectors (The sensor circuit is open or shorted.) • Intake air leaks • Mass air flow sensor • EVAP control system pressure sensor • Intake air temperature sensor

DTC CONFIRMATION PROCEDURE

1. PRECONDITIONING

If DTC Confirmation Procedure has been previously conducted, always turn ignition switch OFF and wait at least 10 seconds before conducting the next test.

If engine will not start or stops soon, wait at least 10 seconds with engine stopped (Ignition switch ON) instead of running engine at idle speed.

>> GO TO 2.

2. PERFORM DTC CONFIRMATION PROCEDURE FOR MALFUNCTION A

1. Start engine and warm it up to normal operating temperature.
2. Run engine for at least 10 seconds at idle speed.
3. Check 1st trip DTC.

Is 1st trip DTC detected?

- YES >> Go to [EC-138, "Diagnosis Procedure"](#).
- NO-1 >> With CONSULT-III: GO TO 3.
- NO-2 >> Without CONSULT-III: GO TO 5.

3. CHECK MASS AIR FLOW SENSOR FUNCTION

1. Turn ignition switch ON.
2. Start engine and warm it up to normal operating temperature.
If engine cannot be started, go to [EC-138, "Diagnosis Procedure"](#).

P0101 MAF SENSOR

[MR18DE]

< DTC/CIRCUIT DIAGNOSIS >

3. Select "DATA MONITOR" mode with CONSULT-III.
4. Check the voltage of "MAS A/F SE-B1" with "DATA MONITOR".
5. Increases engine speed to about 4,000 rpm.
6. Monitor the linear voltage rise in response to engine speed increases.

Is the inspection result normal?

- YES >> GO TO 4.
 NO >> Go to [EC-138, "Diagnosis Procedure"](#).

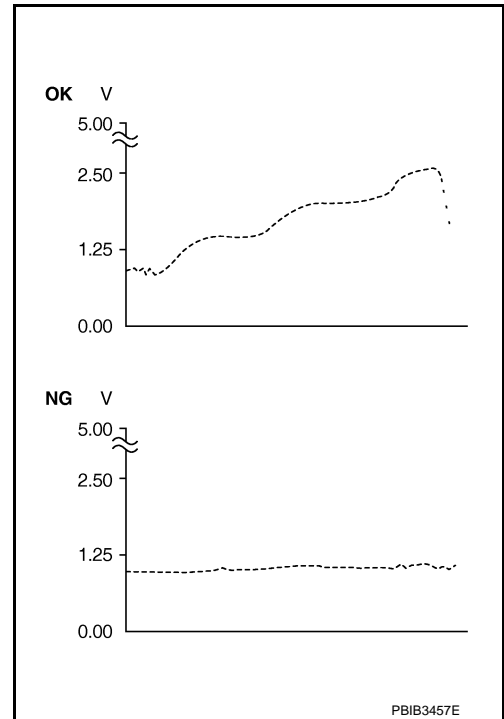

4. PERFORM DTC CONFIRMATION PROCEDURE FOR MALFUNCTION B

1. Maintain the following conditions for at least 10 consecutive seconds.

ENG SPEED	More than 2,000 rpm
TP SEN 1-B1	More than 1.5 V
TP SEN 2-B1	More than 1.5 V
Selector lever	Suitable position
Driving location	Driving vehicle uphill (Increased engine load) will help maintain the driving conditions required for this test.

CAUTION:

Always drive vehicle at a safe speed.

2. Check 1st trip DTC.

Is 1st trip DTC detected?

- YES >> Go to [EC-138, "Diagnosis Procedure"](#).
 NO >> INSPECTION END

5. PERFORM COMPONENT FUNCTION CHECK FOR MALFUNCTION B

Perform component function check. Refer to [EC-137, "Component Function Check"](#).

NOTE:

Use component function check to check the overall function of the mass air flow sensor circuit. During this check, a DTC might not be confirmed.

Is the inspection result normal?

- YES >> INSPECTION END
 NO >> Go to [EC-138, "Diagnosis Procedure"](#).

Component Function Check

INFOID:000000004833231

1. PERFORM COMPONENT FUNCTION CHECK FOR MALFUNCTION B

With GST

1. Start engine and warm it up to normal operating temperature.
2. Select Service \$01 with GST.

P0101 MAF SENSOR

[MR18DE]

< DTC/CIRCUIT DIAGNOSIS >

3. Check the mass air flow sensor signal with Service \$01.
4. Check for linear mass air flow sensor signal value rise in response to increases to about 4,000 rpm in engine speed.

Is the inspection result normal?

- YES >> INSPECTION END
 NO >> Go to [EC-138, "Diagnosis Procedure"](#).

CALC LOAD	20%
COOLANT TEMP	95°C
SHORT FT #1	2%
LONG FT #1	0%
SHORT FT #2	4%
LONG FT #2	0%
ENGINE SPD	2637RPM
VEHICLE SPD	0MPH
IGN ADVANCE	41.0°
INTAKE AIR	41°C
MAF	14.1gm/sec
THROTTLE POS	3%

SEF534P

Diagnosis Procedure

INFOID:000000004833233

1.INSPECTION START

Confirm the detected malfunction (A or B). Refer to [EC-136, "DTC Logic"](#).

Which malfunction is detected?

- A >> GO TO 3.
 B >> GO TO 2.

2.CHECK INTAKE SYSTEM

Check the following for connection.

- Air duct
- Vacuum hoses
- Intake air passage between air duct and intake manifold

Is the inspection result normal?

- YES >> GO TO 3.
 NO >> Reconnect the parts.

3.CHECK GROUND CONNECTION

1. Turn ignition switch OFF.
2. Check ground connection E38. Refer to [GI-37, "Circuit Inspection"](#).

Is the inspection result normal?

- YES >> GO TO 4.
 NO >> Repair or replace ground connection.

4.CHECK MAF SENSOR POWER SUPPLY CIRCUIT

1. Disconnect mass air flow (MAF) sensor harness connector.
2. Turn ignition switch ON.
3. Check the voltage between MAF sensor harness connector and ground.

MAF sensor		Ground	Voltage
Connector	Terminal		
F4	5	Ground	Battery voltage

Is the inspection result normal?

- YES >> GO TO 6.
 NO >> GO TO 5.

5.DETECT MALFUNCTIONING PART

Check the following.

- Harness connectors E8, F1
- Harness for open or short between mass air flow sensor and ECM
- Harness for open or short between mass air flow sensor and IPDM E/R

>> Repair open circuit or short to ground or short to power in harness or connectors.

6.CHECK MAF SENSOR GROUND CIRCUIT FOR OPEN AND SHORT

P0101 MAF SENSOR

[MR18DE]

< DTC/CIRCUIT DIAGNOSIS >

1. Turn ignition switch OFF.
2. Disconnect ECM harness connector.
3. Check the continuity between MAF sensor harness connector and ECM harness connector.

MAF sensor		ECM		Continuity
Connector	Terminal	Connector	Terminal	
F4	4	F8	52	Existed

4. Also check harness for short to ground and short to power.

Is the inspection result normal?

YES >> GO TO 7.

NO >> Repair open circuit or short to ground or short to power in harness or connectors.

7.CHECK MAF SENSOR INPUT SIGNAL CIRCUIT FOR OPEN AND SHORT

1. Check the continuity between MAF sensor harness connector and ECM harness connector.

MAF sensor		ECM		Continuity
Connector	Terminal	Connector	Terminal	
F4	3	F8	45	Existed

2. Also check harness for short to ground and short to power.

Is the inspection result normal?

YES >> GO TO 8.

NO >> Repair open circuit or short to ground or short to power in harness or connectors.

8.CHECK INTAKE AIR TEMPERATURE SENSOR

Check intake air temperature sensor.

Refer to [EC-149, "Component Inspection"](#).

Is the inspection result normal?

YES >> GO TO 9.

NO >> Replace mass air flow sensor (with intake air temperature sensor).

9.CHECK EVAP CONTROL SYSTEM PRESSURE SENSOR

Refer to [EC-269, "Component Inspection"](#).

Is the inspection result normal?

YES >> GO TO 10.

NO >> Replace EVAP control system pressure sensor.

10.CHECK MASS AIR FLOW SENSOR

Refer to [EC-139, "Component Inspection"](#).

Is the inspection result normal?

YES >> GO TO 11.

NO >> Replace mass air flow sensor.

11.CHECK INTERMITTENT INCIDENT

Refer to [GI-34, "Intermittent Incident"](#).

>> INSPECTION END

Component Inspection

INFOID:000000004833234

1.CHECK MASS AIR FLOW SENSOR-I

 **With CONSULT-III**

1. Turn ignition switch OFF.
2. Reconnect all harness connectors disconnected.
3. Start engine and warm it up to normal operating temperature.

P0101 MAF SENSOR

[MR18DE]

< DTC/CIRCUIT DIAGNOSIS >

4. Connect CONSULT-III and select "DATA MONITOR" mode.
5. Select "MAS A/F SE-B1" and check indication.

Monitor item	Condition	MAS A/F SE-B1
MAS A/F SE-B1	Ignition switch ON (Engine stopped.)	Approx. 0.4 V
	Idle (Engine is warmed-up to normal operating temperature.)	0.7 - 1.1 V
	2,500 rpm (Engine is warmed-up to normal operating temperature.)	1.3 - 1.7 V
	Idle to about 4,000 rpm	0.7 - 1.1 V to Approx. 2.4 V*

*: Check for linear voltage rise in response to engine being increased to about 4,000 rpm.

⊗ Without CONSULT-III

1. Turn ignition switch OFF.
2. Reconnect all harness connectors disconnected.
3. Start engine and warm it up to normal operating temperature.
4. Check the voltage between ECM harness connector and ground.

ECM		Ground	Condition	Voltage
Connector	Terminal			
F8	45 (MAF sensor signal)	Ground	Ignition switch ON (Engine stopped.)	Approx. 0.4 V
			Idle (Engine is warmed-up to normal operating temperature.)	0.7 - 1.1 V
			2,500 rpm (Engine is warmed-up to normal operating temperature.)	1.3 - 1.7 V
			Idle to about 4,000 rpm	0.7 - 1.1 V to Approx. 2.4 V*

*: Check for linear voltage rise in response to engine being increased to about 4,000 rpm.

Is the inspection result normal?

- YES >> INSPECTION END
 NO >> GO TO 2.

2. CHECK FOR THE CAUSE OF UNEVEN AIR FLOW THROUGH MASS AIR FLOW SENSOR

1. Turn ignition switch OFF.
2. Check for the cause of uneven air flow through mass air flow sensor. Refer to the following.
 - Crushed air ducts
 - Malfunctioning seal of air cleaner element
 - Uneven dirt of air cleaner element
 - Improper specification of intake air system parts

Is the inspection result normal?

- YES >> GO TO 4.
 NO >> GO TO 3.

3. CHECK MASS AIR FLOW SENSOR-II

Ⓜ With CONSULT-III

1. Repair or replace malfunctioning part.
2. Start engine and warm it up to normal operating temperature.
3. Connect CONSULT-III and select "DATA MONITOR" mode.
4. Select "MAS A/F SE-B1" and check indication.

P0101 MAF SENSOR

< DTC/CIRCUIT DIAGNOSIS >

[MR18DE]

Monitor item	Condition	MAS A/F SE-B1
MAS A/F SE-B1	Ignition switch ON (Engine stopped.)	Approx. 0.4 V
	Idle (Engine is warmed-up to normal operating temperature.)	0.7 - 1.1 V
	2,500 rpm (Engine is warmed-up to normal operating temperature.)	1.3 - 1.7 V
	Idle to about 4,000 rpm	0.7 - 1.1 V to Approx. 2.4 V*

*: Check for linear voltage rise in response to engine being increased to about 4,000 rpm.

⊗ Without CONSULT-III

1. Repair or replace malfunctioning part.
2. Start engine and warm it up to normal operating temperature.
3. Check the voltage between ECM harness connector and ground.

ECM		Ground	Condition	Voltage
Connector	Terminal			
F8	45 (MAF sensor signal)	Ground	Ignition switch ON (Engine stopped.)	Approx. 0.4 V
			Idle (Engine is warmed-up to normal operating temperature.)	0.7 - 1.1 V
			2,500 rpm (Engine is warmed-up to normal operating temperature.)	1.3 - 1.7 V
			Idle to about 4,000 rpm	0.7 - 1.1 V to Approx. 2.4 V*

*: Check for linear voltage rise in response to engine being increased to about 4,000 rpm.

Is the inspection result normal?

- YES >> INSPECTION END
 NO >> GO TO 4.

4. CHECK MASS AIR FLOW SENSOR-III

Ⓜ With CONSULT-III

1. Turn ignition switch OFF.
2. Disconnect mass air flow sensor harness connector and reconnect it again.
3. Start engine and warm it up to normal operating temperature.
4. Connect CONSULT-III and select "DATA MONITOR" mode.
5. Select "MAS A/F SE-B1" and check indication.

Monitor item	Condition	MAS A/F SE-B1
MAS A/F SE-B1	Ignition switch ON (Engine stopped.)	Approx. 0.4 V
	Idle (Engine is warmed-up to normal operating temperature.)	0.7 - 1.1 V
	2,500 rpm (Engine is warmed-up to normal operating temperature.)	1.3 - 1.7 V
	Idle to about 4,000 rpm	0.7 - 1.1 V to Approx. 2.4 V*

*: Check for linear voltage rise in response to engine being increased to about 4,000 rpm.

⊗ Without CONSULT-III

1. Turn ignition switch OFF.
2. Disconnect mass air flow sensor harness connector and reconnect it again.
3. Start engine and warm it up to normal operating temperature.
4. Check the voltage between ECM harness connector and ground.

P0101 MAF SENSOR

< DTC/CIRCUIT DIAGNOSIS >

[MR18DE]

ECM		Ground	Condition	Voltage
Connector	Terminal			
F11	45 (MAF sensor signal)	Ground	Ignition switch ON (Engine stopped.)	Approx. 0.4 V
			Idle (Engine is warmed-up to normal operating temperature.)	0.7 - 1.1 V
			2,500 rpm (Engine is warmed-up to normal operating temperature.)	1.3 - 1.7 V
			Idle to about 4,000 rpm	0.7 - 1.1 V to Ap- prox. 2.4 V*

*: Check for linear voltage rise in response to engine being increased to about 4,000 rpm.

Is the inspection result normal?

YES >> INSPECTION END

NO >> Clean or replace mass air flow sensor.

P0102, P0103 MAF SENSOR

Description

INFOID:000000004833235

The mass air flow sensor (1) is placed in the stream of intake air. It measures the intake flow rate by measuring a part of the entire intake flow. The mass air flow sensor controls the temperature of the hot wire to a certain amount. The heat generated by the hot wire is reduced as the intake air flows around it. The more air, the greater the heat loss. Therefore, the electric current supplied to hot wire is changed to maintain the temperature of the hot wire as air flow increases. The ECM detects the air flow by means of this current change.

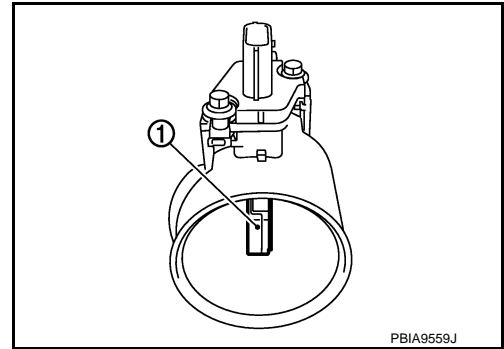

DTC Logic

INFOID:000000004833236

DTC DETECTION LOGIC

DTC No.	Trouble diagnosis name	DTC detecting condition	Possible cause
P0102	Mass air flow sensor circuit low input	An excessively low voltage from the sensor is sent to ECM.	<ul style="list-style-type: none"> • Harness or connectors (The sensor circuit is open or shorted.) • Intake air leaks • Mass air flow sensor
P0103	Mass air flow sensor circuit high input	An excessively high voltage from the sensor is sent to ECM.	<ul style="list-style-type: none"> • Harness or connectors (The sensor circuit is open or shorted.) • Mass air flow sensor

DTC CONFIRMATION PROCEDURE

1. PRECONDITIONING

If DTC Confirmation Procedure has been previously conducted, always turn ignition switch OFF and wait at least 10 seconds before conducting the next test.

Which DTC is detected?

- P0102 >> GO TO 2.
- P0103 >> GO TO 3.

2. PERFORM DTC CONFIRMATION PROCEDURE FOR DTC P0102

1. Start engine and wait at least 5 seconds.
2. Check DTC.

Is DTC detected?

- YES >> Go to [EC-144. "Diagnosis Procedure"](#).
- NO >> INSPECTION END

3. PERFORM DTC CONFIRMATION PROCEDURE FOR DTC P0103-I

1. Turn ignition switch ON and wait at least 5 seconds.
2. Check DTC.

Is DTC detected?

- YES >> Go to [EC-144. "Diagnosis Procedure"](#).
- NO >> GO TO 4.

4. PERFORM DTC CONFIRMATION PROCEDURE FOR DTC P0103-II

1. Start engine and wait at least 5 seconds.
2. Check DTC.

Is DTC detected?

- YES >> Go to [EC-144. "Diagnosis Procedure"](#).
- NO >> INSPECTION END

P0102, P0103 MAF SENSOR

[MR18DE]

< DTC/CIRCUIT DIAGNOSIS >

Diagnosis Procedure

INFOID:000000004833238

1.INSPECTION START

Confirm the detected DTC.

Which DTC is detected?

P0102 >> GO TO 2.

P0103 >> GO TO 3.

2.CHECK INTAKE SYSTEM

Check the following for connection.

- Air duct
- Vacuum hoses
- Intake air passage between air duct to intake manifold

Is the inspection result normal?

YES >> GO TO 3.

NO >> Reconnect the parts.

3.CHECK GROUND CONNECTION

1. Turn ignition switch OFF.
2. Check ground connection E38. Refer to [GI-37, "Circuit Inspection"](#).

Is the inspection result normal?

YES >> GO TO 4.

NO >> Repair or replace ground connection.

4.CHECK MAF SENSOR POWER SUPPLY CIRCUIT

1. Disconnect mass air flow (MAF) sensor harness connector.
2. Turn ignition switch ON.
3. Check the voltage between MAF sensor harness connector and ground.

MAF sensor		Ground	Voltage
Connector	Terminal		
F4	5	Ground	Battery voltage

Is the inspection result normal?

YES >> GO TO 6.

NO >> GO TO 5.

5.DETECT MALFUNCTIONING PART

Check the following.

- Harness connectors E8,F1
- Harness for open or short between mass air flow sensor and ECM
- Harness for open or short between mass air flow sensor and IPDM E/R

>> Repair open circuit or short to ground or short to power in harness or connectors.

6.CHECK MAF SENSOR GROUND CIRCUIT FOR OPEN AND SHORT

1. Turn ignition switch OFF.
2. Disconnect ECM harness connector.
3. Check the continuity between MAF sensor harness connector and ECM harness connector.

MAF sensor		ECM		Continuity
Connector	Terminal	Connector	Terminal	
F4	4	F8	52	Existed

4. Also check harness for short to ground and short to power.

Is the inspection result normal?

P0102, P0103 MAF SENSOR

[MR18DE]

< DTC/CIRCUIT DIAGNOSIS >

- YES >> GO TO 7.
 NO >> Repair open circuit or short to ground or short to power in harness or connectors.

7.CHECK MAF SENSOR INPUT SIGNAL CIRCUIT FOR OPEN AND SHORT

1. Check the continuity between MAF sensor harness connector and ECM harness connector.

MAF sensor		ECM		Continuity
Connector	Terminal	Connector	Terminal	
F4	3	F8	45	Existed

2. Also check harness for short to ground and short to power.

Is the inspection result normal?

- YES >> GO TO 8.
 NO >> Repair open circuit or short to ground or short to power in harness or connectors.

8.CHECK MASS AIR FLOW SENSOR

Refer to [EC-145, "Component Inspection"](#).

Is the inspection result normal?

- YES >> GO TO 9.
 NO >> Replace mass air flow sensor.

9.CHECK INTERMITTENT INCIDENT

Refer to [GI-34, "Intermittent Incident"](#).

>> INSPECTION END

Component Inspection

INFOID:000000004833239

1.CHECK MASS AIR FLOW SENSOR-I

With CONSULT-III

- Turn ignition switch OFF.
- Reconnect all harness connectors disconnected.
- Start engine and warm it up to normal operating temperature.
- Connect CONSULT-III and select "DATA MONITOR" mode.
- Select "MAS A/F SE-B1" and check indication.

Monitor item	Condition	MAS A/F SE-B1
MAS A/F SE-B1	Ignition switch ON (Engine stopped.)	Approx. 0.4 V
	Idle (Engine is warmed-up to normal operating temperature.)	0.7 - 1.1 V
	2,500 rpm (Engine is warmed-up to normal operating temperature.)	1.3 - 1.7 V
	Idle to about 4,000 rpm	0.7 - 1.1 V to Approx. 2.4 V*

*: Check for linear voltage rise in response to engine being increased to about 4,000 rpm.

Without CONSULT-III

- Turn ignition switch OFF.
- Reconnect all harness connectors disconnected.
- Start engine and warm it up to normal operating temperature.
- Check the voltage between ECM harness connector and ground.

P0102, P0103 MAF SENSOR

[MR18DE]

< DTC/CIRCUIT DIAGNOSIS >

ECM		Ground	Condition	Voltage
Connector	Terminal			
F8	45 (MAF sensor signal)	Ground	Ignition switch ON (Engine stopped.)	Approx. 0.4 V
			Idle (Engine is warmed-up to normal operating temperature.)	0.7 - 1.1 V
			2,500 rpm (Engine is warmed-up to normal operating temperature.)	1.3 - 1.7 V
			Idle to about 4,000 rpm	0.7 - 1.1 V to Approx. 2.4 V*

*: Check for linear voltage rise in response to engine being increased to about 4,000 rpm.

Is the inspection result normal?

- YES >> INSPECTION END
 NO >> GO TO 2.

2.CHECK FOR THE CAUSE OF UNEVEN AIR FLOW THROUGH MASS AIR FLOW SENSOR

- Turn ignition switch OFF.
- Check for the cause of uneven air flow through mass air flow sensor. Refer to the following.
 - Crushed air ducts
 - Malfunctioning seal of air cleaner element
 - Uneven dirt of air cleaner element
 - Improper specification of intake air system parts

Is the inspection result normal?

- YES >> GO TO 4.
 NO >> GO TO 3.

3.CHECK MASS AIR FLOW SENSOR-II

With CONSULT-III

- Repair or replace malfunctioning part.
- Start engine and warm it up to normal operating temperature.
- Connect CONSULT-III and select "DATA MONITOR" mode.
- Select "MAS A/F SE-B1" and check indication.

Monitor item	Condition	MAS A/F SE-B1
MAS A/F SE-B1	Ignition switch ON (Engine stopped.)	Approx. 0.4 V
	Idle (Engine is warmed-up to normal operating temperature.)	0.7 - 1.1 V
	2,500 rpm (Engine is warmed-up to normal operating temperature.)	1.3 - 1.7 V
	Idle to about 4,000 rpm	0.7 - 1.1 V to Approx. 2.4 V*

*: Check for linear voltage rise in response to engine being increased to about 4,000 rpm.

Without CONSULT-III

- Repair or replace malfunctioning part.
- Start engine and warm it up to normal operating temperature.
- Check the voltage between ECM harness connector and ground.

P0102, P0103 MAF SENSOR

[MR18DE]

< DTC/CIRCUIT DIAGNOSIS >

ECM		Ground	Condition	Voltage
Connector	Terminal			
F8	45 (MAF sensor signal)	Ground	Ignition switch ON (Engine stopped.)	Approx. 0.4 V
			Idle (Engine is warmed-up to normal operating temperature.)	0.7 - 1.1 V
			2,500 rpm (Engine is warmed-up to normal operating temperature.)	1.3 - 1.7 V
			Idle to about 4,000 rpm	0.7 - 1.1 V to Approx. 2.4 V*

*: Check for linear voltage rise in response to engine being increased to about 4,000 rpm.

Is the inspection result normal?

- YES >> INSPECTION END
 NO >> GO TO 4.

4. CHECK MASS AIR FLOW SENSOR-III

With CONSULT-III

1. Turn ignition switch OFF.
2. Disconnect mass air flow sensor harness connector and reconnect it again.
3. Start engine and warm it up to normal operating temperature.
4. Connect CONSULT-III and select "DATA MONITOR" mode.
5. Select "MAS A/F SE-B1" and check indication.

Monitor item	Condition	MAS A/F SE-B1
MAS A/F SE-B1	Ignition switch ON (Engine stopped.)	Approx. 0.4 V
	Idle (Engine is warmed-up to normal operating temperature.)	0.7 - 1.1 V
	2,500 rpm (Engine is warmed-up to normal operating temperature.)	1.3 - 1.7 V
	Idle to about 4,000 rpm	0.7 - 1.1 V to Approx. 2.4 V*

*: Check for linear voltage rise in response to engine being increased to about 4,000 rpm.

Without CONSULT-III

1. Turn ignition switch OFF.
2. Disconnect mass air flow sensor harness connector and reconnect it again.
3. Start engine and warm it up to normal operating temperature.
4. Check the voltage between ECM harness connector and ground.

ECM		Ground	Condition	Voltage
Connector	Terminal			
F11	45 (MAF sensor signal)	Ground	Ignition switch ON (Engine stopped.)	Approx. 0.4 V
			Idle (Engine is warmed-up to normal operating temperature.)	0.7 - 1.1 V
			2,500 rpm (Engine is warmed-up to normal operating temperature.)	1.3 - 1.7 V
			Idle to about 4,000 rpm	0.7 - 1.1 V to Approx. 2.4 V*

*: Check for linear voltage rise in response to engine being increased to about 4,000 rpm.

Is the inspection result normal?

- YES >> INSPECTION END
 NO >> Clean or replace mass air flow sensor.

P0112, P0113 IAT SENSOR

< DTC/CIRCUIT DIAGNOSIS >

[MR18DE]

P0112, P0113 IAT SENSOR

Description

INFOID:000000004833240

The intake air temperature sensor is built-into mass air flow sensor (1). The sensor detects intake air temperature and transmits a signal to the ECM.

The temperature sensing unit uses a thermistor which is sensitive to the change in temperature. Electrical resistance of the thermistor decreases in response to the temperature rise.

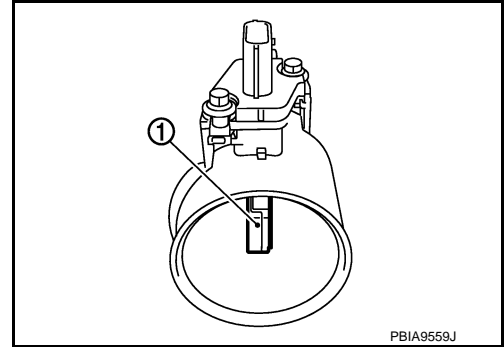

<Reference data>

Intake air temperature [°C (°F)]	Voltage* (V)	Resistance (kΩ)
25 (77)	3.3	1.800 - 2.200
80 (176)	1.2	0.283 - 0.359

*: These data are reference values and are measured between ECM terminal 46 (Intake air temperature sensor) and ground.

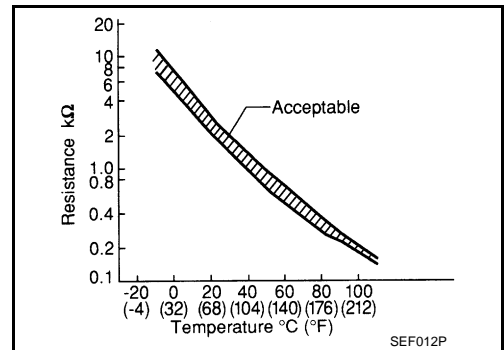

DTC Logic

INFOID:000000004833241

DTC DETECTION LOGIC

DTC No.	Trouble diagnosis name	DTC detecting condition	Possible cause
P0112	Intake air temperature sensor circuit low input	An excessively low voltage from the sensor is sent to ECM.	<ul style="list-style-type: none"> • Harness or connectors (The sensor circuit is open or shorted.) • Intake air temperature sensor
P0113	Intake air temperature sensor circuit high input	An excessively high voltage from the sensor is sent to ECM.	

DTC CONFIRMATION PROCEDURE

1. PRECONDITIONING

If DTC Confirmation Procedure has been previously conducted, always turn ignition switch OFF and wait at least 10 seconds before conducting the next test.

>> GO TO 2.

2. PERFORM DTC CONFIRMATION PROCEDURE

1. Turn ignition switch ON and wait at least 5 seconds.
2. Check 1st trip DTC.

Is 1st trip DTC detected?

- YES >> Go to [EC-148, "Diagnosis Procedure"](#).
 NO >> INSPECTION END

Diagnosis Procedure

INFOID:000000004833243

1. CHECK GROUND CONNECTION

1. Turn ignition switch OFF.
2. Check ground connection E38. Refer to [GI-37, "Circuit Inspection"](#).

P0112, P0113 IAT SENSOR

[MR18DE]

< DTC/CIRCUIT DIAGNOSIS >

Is the inspection result normal?

- YES >> GO TO 2.
- NO >> Repair or replace ground connection.

2.CHECK INTAKE AIR TEMPERATURE SENSOR POWER SUPPLY CIRCUIT

1. Disconnect mass air flow sensor (with intake air temperature sensor) harness connector.
2. Turn ignition switch ON.
3. Check the voltage between mass air flow sensor harness connector and ground.

MAF sensor		Ground	Voltage
Connector	Terminal		
F4	5	Ground	Approx. 5 V

Is the inspection result normal?

- YES >> GO TO 3.
- NO >> Repair open circuit or short to ground or short to power in harness or connectors.

3.CHECK INTAKE AIR TEMPERATURE SENSOR GROUND CIRCUIT FOR OPEN AND SHORT

1. Turn ignition switch OFF.
2. Disconnect ECM harness connector.
3. Check the continuity between mass air flow sensor harness connector and ECM harness connector.

MAF sensor		ECM		Continuity
Connector	Terminal	Connector	Terminal	
F4	4	F8	52	Existed

4. Also check harness for short to ground and short to power.

Is the inspection result normal?

- YES >> GO TO 4.
- NO >> Repair open circuit or short to ground or short to power in harness or connectors.

4.CHECK INTAKE AIR TEMPERATURE SENSOR

Refer to [EC-149. "Component Inspection"](#).

Is the inspection result normal?

- YES >> GO TO 5.
- NO >> Replace mass air flow sensor (with intake air temperature sensor).

5.CHECK INTERMITTENT INCIDENT

Refer to [GI-34. "Intermittent Incident"](#).

>> INSPECTION END

Component Inspection

INFOID:000000004833244

1.CHECK INTAKE AIR TEMPERATURE SENSOR

1. Turn ignition switch OFF.
2. Disconnect mass air flow sensor harness connector.
3. Check resistance between mass air flow sensor terminals as per the following.

Terminals	Condition	Resistance (kΩ)
1 and 2	Intake air temperature [°C (°F)]	25 (77) 1.800 - 2.200

Is the inspection result normal?

- YES >> INSPECTION END
- NO >> Replace mass air flow sensor (with intake air temperature sensor).

P0116 ECT SENSOR

Description

INFOID:000000004833245

The engine coolant temperature sensor is used to detect the engine coolant temperature. The sensor modifies a voltage signal from the ECM. The modified signal returns to the ECM as the engine coolant temperature input. The sensor uses a thermistor which is sensitive to the change in temperature. The electrical resistance of the thermistor decreases as temperature increases.

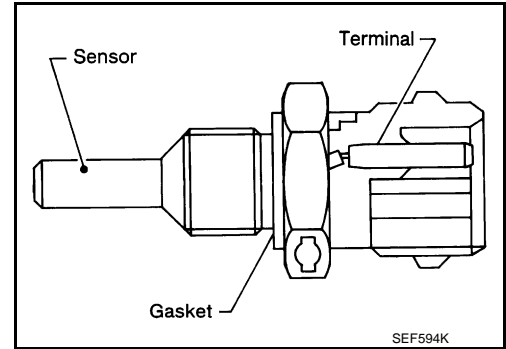

<Reference data>

Engine coolant temperature [°C (°F)]	Voltage* (V)	Resistance (kΩ)
-10 (14)	4.4	7.0 - 11.4
20 (68)	3.5	2.37 - 2.63
50 (122)	2.2	0.68 - 1.00
90 (194)	0.9	0.236 - 0.260

*: These data are reference values and are measured between ECM terminal 38 (Engine coolant temperature sensor) and ground.

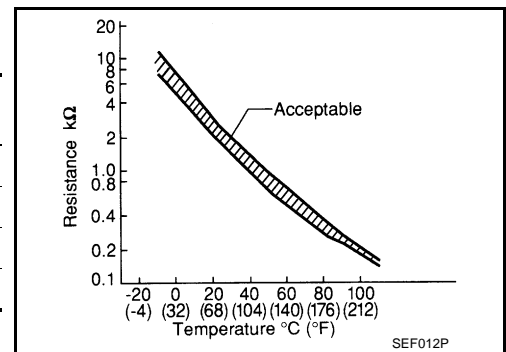

DTC Logic

INFOID:000000004833246

DTC DETECTION LOGIC

NOTE:

If DTC P0116 is displayed with P0117 or P0118, first perform the trouble diagnosis for DTC P0117, P0118. Refer to [EC-152. "DTC Logic"](#).

DTC No.	Trouble diagnosis name	DTC detecting condition	Possible cause
P0116	Engine coolant temperature sensor circuit range/performance	Engine coolant temperature signal from engine coolant temperature sensor does not fluctuate, even when some time has passed after starting the engine with pre-warming up condition.	<ul style="list-style-type: none"> • Harness or connectors (High or low resistance in the circuit) • Engine coolant temperature sensor

DTC CONFIRMATION PROCEDURE

1. PRECONDITIONING

If DTC confirmation procedure has been previously conducted, always turn ignition switch OFF and wait at least 10 seconds before conducting the next test.

>> GO TO 2.

2. PERFORM DTC CONFIRMATION PROCEDURE

1. Start engine and warm it up to normal operating temperature.
2. Rev engine up to 2,000 rpm for more than 10 minutes.
3. Move the vehicle to a cool place, then stop engine and turn ignition switch OFF.
4. Check resistance between "fuel level sensor unit and fuel pump" terminals 4 and 5.
5. Soak the vehicle until the resistance between "fuel level sensor unit and fuel pump" terminals 4 and 5 becomes 0.5 kΩ higher than the value measured before soaking.

CAUTION:

Never turn ignition switch ON during the soaking time.

P0116 ECT SENSOR

[MR18DE]

< DTC/CIRCUIT DIAGNOSIS >

NOTE:

Soak time changes depending on ambient air temperature. It may take several hours.

6. Start engine and let it idle for 5 minutes.
7. Check 1st trip DTC.

Is 1st trip DTC detected?

- YES >> [EC-151, "Diagnosis Procedure"](#).
NO >> INSPECTION END

Diagnosis Procedure

INFOID:000000004833247

1.CHECK GROUND CONNECTION

1. Turn ignition switch OFF.
2. Check ground connection E38. Refer to [GI-37, "Circuit Inspection"](#).

Is the inspection result normal?

- YES >> GO TO 2.
NO >> Repair or replace ground connection.

2.CHECK ENGINE COOLANT TEMPERATURE SENSOR

Refer to [EC-151, "Component Inspection"](#).

Is the inspection result normal?

- YES >> GO TO 3.
NO >> Replace engine coolant temperature sensor.

3.CHECK INTERMITTENT INCIDENT

Refer to [GI-34, "Intermittent Incident"](#).

>> INSPECTION END

Component Inspection

INFOID:000000004833248

1.CHECK ENGINE COOLANT TEMPERATURE SENSOR

1. Turn ignition switch OFF.
2. Disconnect engine coolant temperature sensor harness connector.
3. Remove engine coolant temperature sensor.
4. Check resistance between engine coolant temperature sensor terminals by heating with hot water as shown in the figure.

Terminals	Condition	Resistance	
1 and 2	Temperature [°C (°F)]	20 (68)	2.37 - 2.63 kΩ
		50 (122)	0.68 - 1.00 kΩ
		90 (194)	0.236 - 0.260 kΩ

Is the inspection result normal?

- YES >> INSPECTION END
NO >> Replace engine coolant temperature sensor.

P0117, P0118 ECT SENSOR

< DTC/CIRCUIT DIAGNOSIS >

[MR18DE]

P0117, P0118 ECT SENSOR

Description

INFOID:000000004833249

The engine coolant temperature sensor is used to detect the engine coolant temperature. The sensor modifies a voltage signal from the ECM. The modified signal returns to the ECM as the engine coolant temperature input. The sensor uses a thermistor which is sensitive to the change in temperature. The electrical resistance of the thermistor decreases as temperature increases.

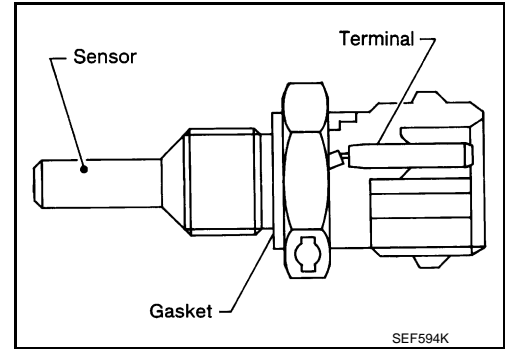

<Reference data>

Engine coolant temperature [°C (°F)]	Voltage* (V)	Resistance (kΩ)
-10 (14)	4.4	7.0 - 11.4
20 (68)	3.5	2.37 - 2.63
50 (122)	2.2	0.68 - 1.00
90 (194)	0.9	0.236 - 0.260

*: These data are reference values and are measured between ECM terminal 38 (Engine coolant temperature sensor) and ground.

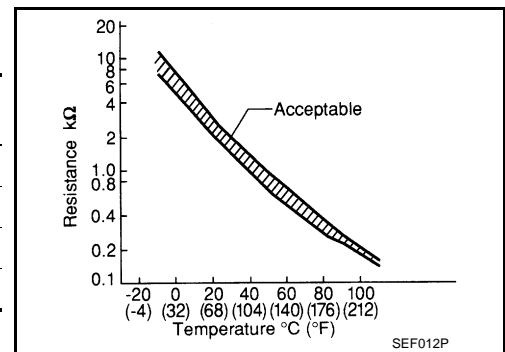

DTC Logic

INFOID:000000004833250

DTC DETECTION LOGIC

DTC No.	Trouble diagnosis name	DTC detecting condition	Possible Cause
P0117	Engine coolant temperature sensor circuit low input	An excessively low voltage from the sensor is sent to ECM.	<ul style="list-style-type: none"> • Harness or connectors (The sensor circuit is open or shorted.) • Engine coolant temperature sensor
P0118	Engine coolant temperature sensor circuit high input	An excessively high voltage from the sensor is sent to ECM.	

DTC CONFIRMATION PROCEDURE

1. PRECONDITIONING

If DTC Confirmation Procedure has been previously conducted, always turn ignition switch OFF and wait at least 10 seconds before conducting the next test.

>> GO TO 2.

2. PERFORM DTC CONFIRMATION PROCEDURE

1. Turn ignition switch ON and wait at least 5 seconds.
2. Check DTC.

Is DTC detected?

- YES >> Go to [EC-152, "Diagnosis Procedure"](#).
 NO >> INSPECTION END

Diagnosis Procedure

INFOID:000000004833252

1. CHECK GROUND CONNECTION

1. Turn ignition switch OFF.

P0117, P0118 ECT SENSOR

[MR18DE]

< DTC/CIRCUIT DIAGNOSIS >

2. Check ground connection E38. Refer to [GI-37, "Circuit Inspection"](#).

Is the inspection result normal?

YES >> GO TO 2.

NO >> Repair or replace ground connection.

2.CHECK ECT SENSOR POWER SUPPLY CIRCUIT

1. Disconnect engine coolant temperature (ECT) sensor harness connector.
2. Turn ignition switch ON.
3. Check the voltage between ECT sensor harness connector and ground.

ECT sensor		Ground	Voltage
Connector	Terminal		
F28	1	Ground	Approx. 5 V

Is the inspection result normal?

YES >> GO TO 3.

NO >> Repair open circuit or short to ground or short to power in harness or connectors.

3.CHECK ECT SENSOR GROUND CIRCUIT FOR OPEN AND SHORT

1. Turn ignition switch OFF.
2. Disconnect ECM harness connector.
3. Check the continuity between ECT sensor harness connector and ECM harness connector.

ECT sensor		ECM		Continuity
Connector	Terminal	Connector	Terminal	
F28	2	F8	44	Existed

4. Also check harness for short to ground and short to power.

Is the inspection result normal?

YES >> GO TO 4.

NO >> Repair open circuit or short to ground or short to power in harness or connectors.

4.CHECK ENGINE COOLANT TEMPERATURE SENSOR

Refer to [EC-153, "Component Inspection"](#).

Is the inspection result normal?

YES >> GO TO 5.

NO >> Replace engine coolant temperature sensor.

5.CHECK INTERMITTENT INCIDENT

Refer to [GI-34, "Intermittent Incident"](#).

>> INSPECTION END

Component Inspection

INFOID:000000004833253

1.CHECK ENGINE COOLANT TEMPERATURE SENSOR

1. Turn ignition switch OFF.
2. Disconnect engine coolant temperature sensor harness connector.
3. Remove engine coolant temperature sensor.
4. Check resistance between engine coolant temperature sensor terminals by heating with hot water as shown in the figure.

Terminals	Condition	Resistance	
1 and 2	Temperature [°C (°F)]	20 (68)	2.37 - 2.63 kΩ
		50 (122)	0.68 - 1.00 kΩ
		90 (194)	0.236 - 0.260 kΩ

P0117, P0118 ECT SENSOR

[MR18DE]

< DTC/CIRCUIT DIAGNOSIS >

Is the inspection result normal?

YES >> INSPECTION END

NO >> Replace engine coolant temperature sensor.

P0122, P0123 TP SENSOR

Description

INFOID:000000004833254

Electric throttle control actuator consists of throttle control motor, throttle position sensor, etc. The throttle position sensor responds to the throttle valve movement.

The throttle position sensor has two sensors. These sensors are a kind of potentiometer which transform the throttle valve position into output voltage, and emit the voltage signals to the ECM. The ECM judges the current opening angle of the throttle valve from these signals and controls the throttle valve opening angle in response to driving conditions via the throttle control motor.

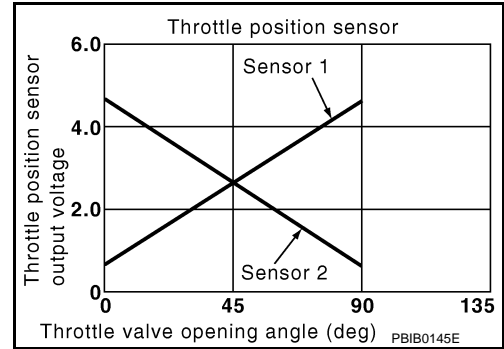

DTC Logic

INFOID:000000004833255

DTC DETECTION LOGIC

NOTE:

If DTC P0122 or P0123 is displayed with DTC P0643, first perform the trouble diagnosis for DTC P0643. Refer to [EC-308, "DTC Logic"](#).

DTC No.	Trouble diagnosis name	DTC detecting condition	Possible cause
P0122	Throttle position sensor 2 circuit low input	An excessively low voltage from the TP sensor 2 is sent to ECM.	<ul style="list-style-type: none"> Harness or connectors (TP sensor 2 circuit is open or shorted.) Electric throttle control actuator (TP sensor 2)
P0123	Throttle position sensor 2 circuit high input	An excessively high voltage from the TP sensor 2 is sent to ECM.	

DTC CONFIRMATION PROCEDURE

1. PRECONDITIONING

If DTC Confirmation Procedure has been previously conducted, always turn ignition switch OFF and wait at least 10 seconds before conducting the next test.

TESTING CONDITION:

Before performing the following procedure, confirm that battery voltage is more than 8 V at idle.

>> GO TO 2.

2. PERFORM DTC CONFIRMATION PROCEDURE

1. Start engine and let it idle for 1 second.
2. Check DTC.

Is DTC detected?

YES >> Go to [EC-155, "Diagnosis Procedure"](#).

NO >> INSPECTION END

Diagnosis Procedure

INFOID:000000004833257

1. CHECK GROUND CONNECTION

1. Turn ignition switch OFF.
2. Check ground connection E38. Refer to [GI-37, "Circuit Inspection"](#).

Is the inspection result normal?

YES >> GO TO 2.

NO >> Repair or replace ground connection.

2. CHECK THROTTLE POSITION SENSOR 2 POWER SUPPLY CIRCUIT

1. Disconnect electric throttle control actuator harness connector.
2. Turn ignition switch ON.

P0122, P0123 TP SENSOR

[MR18DE]

< DTC/CIRCUIT DIAGNOSIS >

3. Check the voltage between electric throttle control actuator harness connector and ground.

Electric throttle control actuator		Ground	Voltage
Connector	Terminal		
F29	2	Ground	Approx. 5 V

Is the inspection result normal?

YES >> GO TO 3.

NO >> Repair open circuit or short to ground or short to power in harness or connectors.

3.CHECK THROTTLE POSITION SENSOR 2 GROUND CIRCUIT FOR OPEN AND SHORT

1. Turn ignition switch OFF.
2. Disconnect ECM harness connector.
3. Check the continuity between electric throttle control actuator harness connector and ECM harness connector.

Electric throttle control actuator		ECM		Continuity
Connector	Terminal	Connector	Terminal	
F29	4	F8	36	Existed

4. Also check harness for short to ground and short to power.

Is the inspection result normal?

YES >> GO TO 4.

NO >> Repair open circuit or short to ground or short to power in harness or connectors.

4.CHECK THROTTLE POSITION SENSOR 2 INPUT SIGNAL CIRCUIT FOR OPEN AND SHORT

1. Check the continuity between electric throttle control actuator harness connector and ECM harness connector.

Electric throttle control actuator		ECM		Continuity
Connector	Terminal	Connector	Terminal	
F29	3	F8	34	Existed

2. Also check harness for short to ground and short to power.

Is the inspection result normal?

YES >> GO TO 5.

NO >> Repair open circuit or short to ground or short to power in harness or connectors.

5.CHECK THROTTLE POSITION SENSOR

Refer to [EC-157, "Component Inspection"](#).

Is the inspection result normal?

YES >> GO TO 7.

NO >> GO TO 6.

6.REPLACE ELECTRIC THROTTLE CONTROL ACTUATOR

1. Replace electric throttle control actuator.
2. Perform [EC-157, "Special Repair Requirement"](#).

>> INSPECTION END

7.CHECK INTERMITTENT INCIDENT

Refer to [GI-34, "Intermittent Incident"](#).

>> INSPECTION END

P0122, P0123 TP SENSOR

< DTC/CIRCUIT DIAGNOSIS >

[MR18DE]

Component Inspection

INFOID:000000004833258

1. CHECK THROTTLE POSITION SENSOR

1. Turn ignition switch OFF.
2. Reconnect all harness connectors disconnected.
3. Perform [EC-17, "THROTTLE VALVE CLOSED POSITION LEARNING : Special Repair Requirement"](#).
4. Turn ignition switch ON.
5. Set selector lever to D (CVT) or 1st (M/T) position.
6. Check the voltage between ECM harness connector and ground.

ECM		Ground	Condition	Voltage	
Connector	Terminal				
F8	33 (TP sensor 1 signal)	Ground	Accelerator pedal	Fully released	More than 0.36V
				Fully de- pressed	Less than 4.75V
	34 (TP sensor 2 signal)			Fully released	Less than 4.75V
				Fully de- pressed	More than 0.36V

Is the inspection result normal?

- YES >> INSPECTION END
NO >> GO TO 2.

2. REPLACE ELECTRIC THROTTLE CONTROL ACTUATOR

1. Replace electric throttle control actuator.
2. Perform [EC-157, "Special Repair Requirement"](#).

>> INSPECTION END

Special Repair Requirement

INFOID:000000004833259

1. PERFORM THROTTLE VALVE CLOSED POSITION LEARNING

Refer to [EC-17, "THROTTLE VALVE CLOSED POSITION LEARNING : Special Repair Requirement"](#)

>> GO TO 2.

2. PERFORM IDLE AIR VOLUME LEARNING

Refer to [EC-17, "IDLE AIR VOLUME LEARNING : Special Repair Requirement"](#)

>> END

P0125 ECT SENSOR

< DTC/CIRCUIT DIAGNOSIS >

[MR18DE]

P0125 ECT SENSOR

Description

INFOID:000000004833260

The engine coolant temperature sensor is used to detect the engine coolant temperature. The sensor modifies a voltage signal from the ECM. The modified signal returns to the ECM as the engine coolant temperature input. The sensor uses a thermistor which is sensitive to the change in temperature. The electrical resistance of the thermistor decreases as temperature increases.

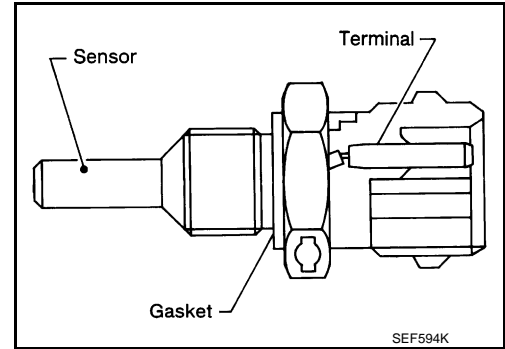

<Reference data>

Engine coolant temperature [°C (°F)]	Voltage* (V)	Resistance (kΩ)
-10 (14)	4.4	7.0 - 11.4
20 (68)	3.5	2.37 - 2.63
50 (122)	2.2	0.68 - 1.00
90 (194)	0.9	0.236 - 0.260

*: These data are reference values and are measured between ECM terminal 38 (Engine coolant temperature sensor) and ground.

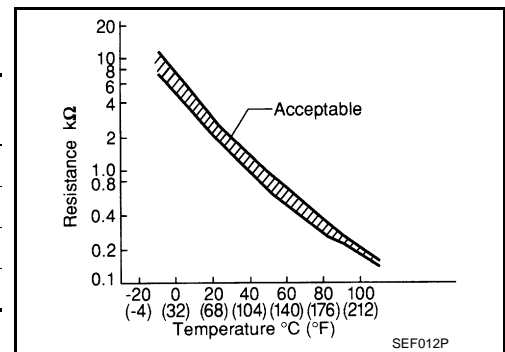

DTC Logic

INFOID:000000004833261

DTC DETECTION LOGIC

NOTE:

- If DTC P0125 is displayed with P0116, first perform the trouble diagnosis for DTC P0116. Refer to [EC-150, "DTC Logic"](#).
- If DTC P0125 is displayed with P0117 or P0118, first perform the trouble diagnosis for DTC P0117 or P0118. Refer to [EC-152, "DTC Logic"](#).

DTC No.	Trouble diagnosis name	DTC detecting condition	Possible cause
P0125	Insufficient engine coolant temperature for closed loop fuel control	<ul style="list-style-type: none"> • Voltage sent to ECM from the sensor is not practical, even when some time has passed after starting the engine. • Engine coolant temperature is insufficient for closed loop fuel control. 	<ul style="list-style-type: none"> • Harness or connectors (High resistance in the circuit) • Engine coolant temperature sensor • Thermostat

DTC CONFIRMATION PROCEDURE

1. PRECONDITIONING

If DTC Confirmation Procedure has been previously conducted, always turn ignition switch OFF and wait at least 10 seconds before conducting the next test.

>> GO TO 2.

2. CHECK ENGINE COOLANT TEMPERATURE SENSOR FUNCTION

With CONSULT-III

1. Turn ignition switch ON.
2. Select "DATA MONITOR" mode with CONSULT-III.
3. Check that "COOLAN TEMP/S" is above 10°C (50°F).

With GST

< DTC/CIRCUIT DIAGNOSIS >

Follow the procedure "With CONSULT-III" above.

Is it above 5°C (41°F)?

- YES >> INSPECTION END
- NO >> GO TO 3.

3.PERFORM DTC CONFIRMATION PROCEDURE

With CONSULT-III

1. Start engine and run it for 65 minutes at idle speed.
2. Check 1st trip DTC.

If "COOLAN TEMP/S" indication increases to more than 10°C (50°F) within 65 minutes, stop engine because the test result will be OK.

CAUTION:

Be careful not to overheat engine.

With GST

Follow the procedure "With CONSULT-III" above.

Is 1st trip DTC detected?

- YES >> [EC-159, "Diagnosis Procedure"](#)
- NO >> INSPECTION END

Diagnosis Procedure

INFOID:000000004833262

1.CHECK GROUND CONNECTION

1. Turn ignition switch OFF.
2. Check ground connection E38. Refer to [GI-37, "Circuit Inspection"](#).

Is the inspection result normal?

- YES >> GO TO 2.
- NO >> Repair or replace ground connection.

2.CHECK ENGINE COOLANT TEMPERATURE SENSOR

Refer to [EC-159, "Component Inspection"](#).

Is the inspection result normal?

- YES >> GO TO 3.
- NO >> Replace engine coolant temperature sensor.

3.CHECK THERMOSTAT OPERATION

When the engine is cold [lower than 70°C (158°F)] condition, grasp lower radiator hose and confirm the engine coolant does not flow.

Is the inspection result normal?

- YES >> GO TO 4.
- NO >> Repair or replace thermostat. Refer to [CO-20, "Removal and Installation"](#).

4.CHECK INTERMITTENT INCIDENT

Refer to [GI-34, "Intermittent Incident"](#).

>> INSPECTION END

Component Inspection

INFOID:000000004833263

1.CHECK ENGINE COOLANT TEMPERATURE SENSOR

1. Turn ignition switch OFF.
2. Disconnect engine coolant temperature sensor harness connector.
3. Remove engine coolant temperature sensor.
4. Check resistance between engine coolant temperature sensor terminals by heating with hot water as shown in the figure.

P0125 ECT SENSOR

< DTC/CIRCUIT DIAGNOSIS >

[MR18DE]

Terminals	Condition	Resistance	
1 and 2	Temperature [°C (°F)]	20 (68)	2.37 - 2.63 kΩ
		50 (122)	0.68 - 1.00 kΩ
		90 (194)	0.236 - 0.260 kΩ

Is the inspection result normal?

YES >> INSPECTION END

NO >> Replace engine coolant temperature sensor.

P0127 IAT SENSOR

< DTC/CIRCUIT DIAGNOSIS >

[MR18DE]

P0127 IAT SENSOR

Description

INFOID:000000004833264

The intake air temperature sensor is built-into mass air flow sensor (1). The sensor detects intake air temperature and transmits a signal to the ECM.

The temperature sensing unit uses a thermistor which is sensitive to the change in temperature. Electrical resistance of the thermistor decreases in response to the temperature rise.

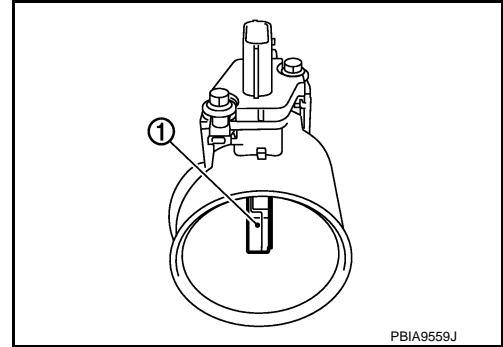

<Reference data>

Intake air temperature [°C (°F)]	Voltage* (V)	Resistance (kΩ)
25 (77)	3.3	1.800 - 2.200
80 (176)	1.2	0.283 - 0.359

*: These data are reference values and are measured between ECM terminal 46 (Intake air temperature sensor) and ground.

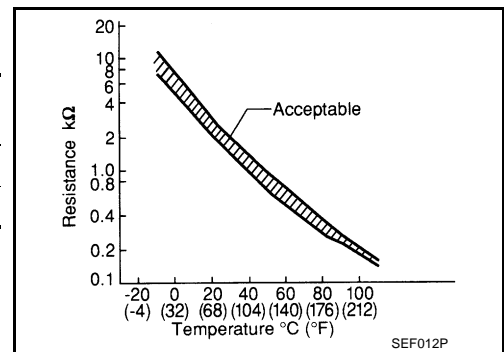

DTC Logic

INFOID:000000004833265

DTC DETECTION LOGIC

DTC No.	Trouble diagnosis name	DTC detecting condition	Possible cause
P0127	Intake air temperature too high	Rationally incorrect voltage from the sensor is sent to ECM, compared with the voltage signal from engine coolant temperature sensor.	<ul style="list-style-type: none"> • Harness or connectors (The sensor circuit is open or shorted) • Intake air temperature sensor

DTC CONFIRMATION PROCEDURE

1. PRECONDITIONING

If DTC Confirmation Procedure has been previously conducted, always turn ignition switch OFF and wait at least 10 seconds before conducting the next test.

TESTING CONDITION:

This test may be conducted with the drive wheels lifted in the shop or by driving the vehicle. If a road test is expected to be easier, it is unnecessary to lift the vehicle.

>> GO TO 2.

2. PERFORM DTC CONFIRMATION PROCEDURE

Ⓜ With CONSULT-III

1. Wait until engine coolant temperature is less than 96°C (205°F)
 - Turn ignition switch ON.
 - Select "DATA MONITOR" mode with CONSULT-III.
 - Check the engine coolant temperature.
 - If the engine coolant temperature is not less than 96°C (205°F), turn ignition switch OFF and cool down engine.

NOTE:

Perform the following steps before engine coolant temperature is above 96°C (205°F).

P0127 IAT SENSOR

[MR18DE]

< DTC/CIRCUIT DIAGNOSIS >

2. Turn ignition switch ON.
3. Select "DATA MONITOR" mode with CONSULT-III.
4. Start engine.
5. Hold vehicle speed at more than 70 km/h (43 MPH) for 95 consecutive seconds.

CAUTION:

Always drive vehicle at a safe speed.

6. Check 1st trip DTC.

 **With GST**

Follow the procedure "With CONSULT-III" above.

Is 1st trip DTC detected?

- YES >> Go to [EC-162, "Diagnosis Procedure"](#).
NO >> INSPECTION END

Diagnosis Procedure

INFOID:00000000483266

1.CHECK GROUND CONNECTION

1. Turn ignition switch OFF.
2. Check ground connection E38. Refer to [GI-37, "Circuit Inspection"](#).

Is the inspection result normal?

- YES >> GO TO 2.
NO >> Repair or replace ground connection.

2.CHECK INTAKE AIR TEMPERATURE SENSOR

Refer to [EC-162, "Component Inspection"](#).

Is the inspection result normal?

- YES >> GO TO 3.
NO >> Replace mass air flow sensor (with intake air temperature sensor).

3.CHECK INTERMITTENT INCIDENT

Refer to [GI-34, "Intermittent Incident"](#).

>> INSPECTION END

Component Inspection

INFOID:00000000483267

1.CHECK INTAKE AIR TEMPERATURE SENSOR

1. Turn ignition switch OFF.
2. Disconnect mass air flow sensor harness connector.
3. Check resistance between mass air flow sensor terminals as per the following.

Terminals	Condition	Resistance (k Ω)
1 and 2	Intake air temperature [$^{\circ}$ C ($^{\circ}$ F)]	25 (77) 1.800 - 2.200

Is the inspection result normal?

- YES >> INSPECTION END
NO >> Replace mass air flow sensor (with intake air temperature sensor).

P0128 THERMOSTAT FUNCTION

< DTC/CIRCUIT DIAGNOSIS >

[MR18DE]

P0128 THERMOSTAT FUNCTION

DTC Logic

INFOID:000000005040130

DTC DETECTION LOGIC

NOTE:

If DTC P0128 is displayed with DTC P0300, P0301, P0302, P0303 or P0304, first perform the trouble diagnosis for DTC P0300, P0301, P0302, P0303, P0304. Refer to [EC-217. "DTC Logic"](#).

Engine coolant temperature has not risen enough to open the thermostat even though the engine has run long enough.

This is due to a leak in the seal or the thermostat stuck open.

DTC No.	Trouble diagnosis name	DTC detecting condition	Possible cause
P0128	Thermostat function	The engine coolant temperature does not reach to specified temperature even though the engine has run long enough.	<ul style="list-style-type: none">• Thermostat• Leakage from sealing portion of thermostat• Engine coolant temperature sensor

DTC CONFIRMATION PROCEDURE

1. PRECONDITIONING

If DTC CONFIRMATION PROCEDURE has been previously conducted, always turn ignition switch OFF and wait at least 10 seconds before conducting the next test.

TESTING CONDITION:

- For best results, perform at ambient temperature of -10°C (14°F) or higher.
- For best results, perform at engine coolant temperature of -10°C (14°F) to 52°C (126°F).
- Before performing the following procedure, do not fill with the fuel.

>> GO TO 2.

2. PERFORM DTC CONFIRMATION PROCEDURE

With CONSULT-III

1. Turn A/C switch OFF.
2. Turn blower fan switch OFF.
3. Turn ignition switch ON.
4. Select "COOLAN TEMP/S" in "DATA MONITOR" mode with CONSULT-III.
5. Check the indication of "COOLAN TEMP/S"
If it is below 52°C (126°F), go to following step.
If it is above 52°C (126°F), cool down the engine to less than 52°C (126°F). Then go to next steps.
6. Start engine.
7. Drive vehicle for 10 consecutive minutes under the following conditions.

VHCL SPEED SE	More than 56km/h (35MPH)
---------------	--------------------------

CAUTION:

Always drive vehicle at a safe speed.

NOTE:

If "COOLAN TEMP/S" indication increases to more than 71°C (160°F) within 10 minutes, turn ignition switch OFF because the test result will be OK.

8. Check 1st trip DTC.

With GST

Follow the procedure "With CONSULT-III" above.

Is 1st trip DTC detected?

- YES >> Go to [EC-163. "Diagnosis Procedure"](#).
- NO >> INSPECTION END

Diagnosis Procedure

INFOID:000000005040131

1. CHECK ENGINE COOLANT TEMPERATURE SENSOR

Refer to [EC-164. "Component Inspection"](#).

P0128 THERMOSTAT FUNCTION

[MR18DE]

< DTC/CIRCUIT DIAGNOSIS >

Is the inspection result normal?

- YES >> GO TO 2.
- NO >> Replace engine coolant temperature sensor.

2.CHECK THERMOSTAT

Refer to [CO-21, "Inspection"](#).

Is the inspection result normal?

- YES >> INSPECTION END
- NO >> Replace thermostat.

Component Inspection

INFOID:000000005040132

1.CHECK ENGINE COOLANT TEMPERATURE SENSOR

1. Turn ignition switch OFF.
2. Disconnect engine coolant temperature sensor harness connector.
3. Remove engine coolant temperature sensor.
4. Check resistance between engine coolant temperature sensor terminals by heating with hot water as shown in the figure.

Terminals	Condition	Resistance	
1 and 2	Temperature [°C (°F)]	20 (68)	2.37 - 2.63 kΩ
		50 (122)	0.68 - 1.00 kΩ
		90 (194)	0.236 - 0.260 kΩ

Is the inspection result normal?

- YES >> INSPECTION END
- NO >> Replace engine coolant temperature sensor.

P0130 A/F SENSOR 1

Description

INFOID:000000004833271

The air fuel ratio (A/F) sensor 1 is a planar one-cell limit current sensor. The sensor element of the A/F sensor 1 is composed an electrode layer, which transports ions. It has a heater in the element. The sensor is capable of precise measurement $\lambda = 1$, but also in the lean and rich range. Together with its control electronics, the sensor outputs a clear, continuous signal throughout a wide λ range. The exhaust gas components diffuse through the diffusion layer at the sensor cell. An electrode layer is applied voltage, and this current relative oxygen density in lean. Also this current relative hydrocarbon density in rich.

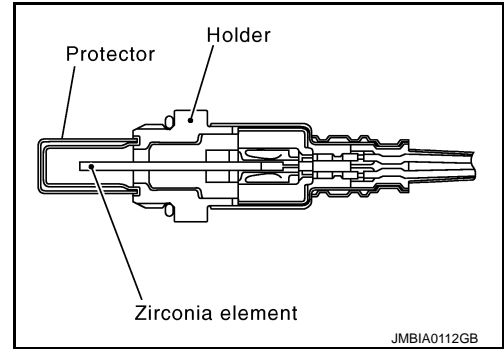

Therefore, the A/F sensor 1 is able to indicate air fuel ratio by this electrode layer of current. In addition, a heater is integrated in the sensor to ensure the required operating temperature of about 800°C (1,472°F).

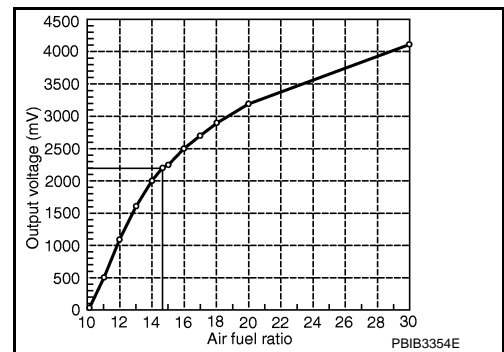

DTC Logic

INFOID:000000004833272

DTC DETECTION LOGIC

To judge the malfunction, the diagnosis checks that the A/F signal computed by ECM from the A/F sensor 1 signal fluctuates according to fuel feedback control.

DTC No.	Trouble diagnosis name	DTC detecting condition		Possible Cause
P0130	Air fuel ratio (A/F) sensor 1 circuit	A)	The A/F signal computed by ECM from the A/F sensor 1 signal is constantly in the range other than approx. 2.2 V.	<ul style="list-style-type: none"> • Harness or connectors (The A/F sensor 1 circuit is open or shorted.) • A/F sensor 1
		B)	The A/F signal computed by ECM from the A/F sensor 1 signal is constantly approx. 2.2 V.	

DTC CONFIRMATION PROCEDURE

1. PRECONDITIONING

If DTC Confirmation Procedure has been previously conducted, always turn ignition switch OFF and wait at least 10 seconds before conducting the next test.

TESTING CONDITION:

Before performing the following procedure, confirm that battery voltage is more than 11 V at idle.

>> GO TO 2.

2. PERFORM DTC CONFIRMATION PROCEDURE FOR MALFUNCTION A

Ⓜ With CONSULT-III

1. Start engine and warm it up to normal operating temperature.
2. Let it idle for 2 minutes.
3. Check 1st trip DTC.

Is 1st trip DTC detected?

YES >> Go to [EC-167, "Diagnosis Procedure"](#).

< DTC/CIRCUIT DIAGNOSIS >

- NO-1 >> With CONSULT-III: GO TO 3.
- NO-2 >> Without CONSULT-III: GO TO 7.

3. CHECK AIR FUEL RATIO (A/F) SENSOR 1 FUNCTION

1. Select "A/F SEN1 (B1)" in "DATA MONITOR" mode with CONSULT-III.
2. Check "A/F SEN1 (B1)" indication.

Does the indication fluctuate around 2.2 V?

- YES >> GO TO 4.
- NO >> Go to [EC-167. "Diagnosis Procedure"](#).

4. PERFORM DTC CONFIRMATION PROCEDURE FOR MALFUNCTION B-I

1. Select "A/F SEN1 (B1) P1276" of "A/F SEN1" in "DTC WORK SUPPORT" mode with CONSULT-III.
2. Touch "START".
3. When the following conditions are met, "TESTING" will be displayed on the CONSULT-III screen.

ENG SPEED	1,000 - 3,200 rpm
VHCL SPEED SE	More than 64 km/h (40 mph)
B/FUEL SCHDL	1.0 - 8.0 msec
Selector lever	D position (CVT) 5th position (M/T)

If "TESTING" is not displayed after 20 seconds, retry from step 2.

CAUTION:

Always drive vehicle at a safe speed.

Is "TESTING" displayed on CONSULT-III screen?

- YES >> GO TO 5.
- NO >> Check A/F sensor 1 function again. GO TO 3.

5. PERFORM DTC CONFIRMATION PROCEDURE FOR MALFUNCTION B-II

Release accelerator pedal fully.

NOTE:

Never apply brake during releasing the accelerator pedal.

Which does "TESTING" change to?

- COMPLETED>>GO TO 6.
- OUT OF CONDITION>>Retry DTC CONFIRMATION PROCEDURE. GO TO 4.

6. PERFORM DTC CONFIRMATION PROCEDURE FOR MALFUNCTION B-III

Touch "SELF-DIAG RESULT"

Which is displayed on CONSULT-III screen?

- YES >> INSPECTION END
- NO >> Go to [EC-167. "Diagnosis Procedure"](#).

7. PERFORM COMPONENT FUNCTION CHECK FOR MALFUNCTION B

Perform Component Function Check. Refer to [EC-166. "Component Function Check"](#).

NOTE:

Use component function check to check the overall function of the A/F sensor 1 circuit. During this check, a 1st trip DTC might not be confirmed.

Is the inspection result normal?

- YES >> INSPECTION END
- NO >> Go to [EC-167. "Diagnosis Procedure"](#).

Component Function Check

INFOID:000000004833273

1. PERFORM COMPONENT FUNCTION CHECK

 **With GST**

1. Start engine and warm it up to normal operating temperature.
2. Drive the vehicle at a speed of 80 km/h (50 MPH) for a few minutes in the suitable gear position.

P0130 A/F SENSOR 1

[MR18DE]

< DTC/CIRCUIT DIAGNOSIS >

- Shift the selector lever to the D position (CVT) or 1st position (M/T), then release the accelerator pedal fully until the vehicle speed decreases to 50 km/h (31 MPH).

CAUTION:

Always drive vehicle at a safe speed.

NOTE:

Never apply brake during releasing the accelerator pedal.

- Repeat steps 2 to 3 for five times.
- Stop the vehicle and turn ignition switch OFF.
- Wait at least 10 seconds and restart engine.
- Repeat steps 2 to 3 for five times.
- Stop the vehicle.
- Check 1st trip DTC.

Is 1st trip DTC detected?

- YES >> Go to [EC-167, "Diagnosis Procedure"](#).
NO >> INSPECTION END

Diagnosis Procedure

INFOID:000000004833275

1. CHECK GROUND CONNECTION

- Turn ignition switch OFF.
- Check ground connection E38. Refer to [GI-37, "Circuit Inspection"](#).

Is the inspection result normal?

- YES >> GO TO 2.
NO >> Repair or replace ground connection.

2. CHECK AIR FUEL RATIO (A/F) SENSOR 1 POWER SUPPLY CIRCUIT

- Disconnect A/F sensor 1 harness connector.
- Turn ignition switch ON.
- Check the voltage between A/F sensor 1 harness connector and ground.

A/F sensor 1		Ground	Voltage
Connector	Terminal		
F50	4	Ground	Battery voltage

Is the inspection result normal?

- YES >> GO TO 4.
NO >> GO TO 3.

3. DETECT MALFUNCTIONING PART

Check the following.

- Harness connectors E8, F1
- IPDM E/R harness connector E15
- 15 A fuse (No. 61)
- Harness for open or short between A/F sensor 1 and fuse

>> Repair or replace harness or connectors.

4. CHECK A/F SENSOR 1 INPUT SIGNAL CIRCUIT FOR OPEN AND SHORT

- Turn ignition switch OFF.
- Disconnect ECM harness connector.
- Check the continuity between A/F sensor 1 harness connector and ECM harness connector.

A/F sensor 1		ECM		Continuity
Connector	Terminal	Connector	Terminal	
F50	1	F8	49	Existed
	2		53	

P0130 A/F SENSOR 1

[MR18DE]

< DTC/CIRCUIT DIAGNOSIS >

4. Check the continuity between A/F sensor 1 harness connector and ground, or ECM harness connector and ground.

A/F sensor 1		Ground	Continuity
Connector	Terminal		
F50	1	Ground	Not existed
	2		

ECM		Ground	Continuity
Connector	Terminal		
F8	49	Ground	Not existed
	53		

5. Also check harness for short to power.

Is the inspection result normal?

YES >> GO TO 5.

NO >> Repair open circuit or short to ground or short to power in harness or connectors.

5.CHECK INTERMITTENT INCIDENT

Perform [GI-34. "Intermittent Incident"](#).

Is the inspection result normal?

YES >> GO TO 6.

NO >> Repair or replace.

6.REPLACE AIR FUEL RATIO (A/F) SENSOR 1

Replace air fuel ratio (A/F) sensor 1.

CAUTION:

- Discard any sensor which has been dropped from a height of more than 0.5 m (19.7 in) onto a hard surface such as a concrete floor; use a new one.
- Before installing new sensor, clean exhaust system threads using Oxygen Sensor Thread Cleaner [commercial service tool (J-43897-18 or J43897-12)] and approved Anti-seize Lubricant (commercial service tool).

>> INSPECTION END

P0131 A/F SENSOR 1

Description

INFOID:000000004833276

The air fuel ratio (A/F) sensor 1 is a planar one-cell limit current sensor. The sensor element of the A/F sensor 1 is composed an electrode layer, which transports ions. It has a heater in the element. The sensor is capable of precise measurement $\lambda = 1$, but also in the lean and rich range. Together with its control electronics, the sensor outputs a clear, continuous signal throughout a wide λ range. The exhaust gas components diffuse through the diffusion layer at the sensor cell. An electrode layer is applied voltage, and this current relative oxygen density in lean. Also this current relative hydrocarbon density in rich.

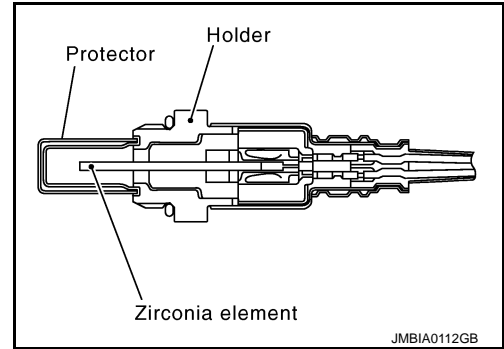

Therefore, the A/F sensor 1 is able to indicate air fuel ratio by this electrode layer of current. In addition, a heater is integrated in the sensor to ensure the required operating temperature of about 800°C (1,472°F).

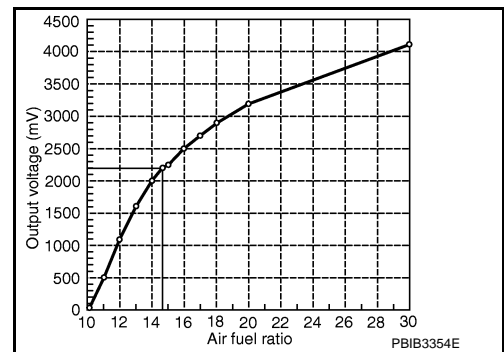

DTC Logic

INFOID:000000004833277

DTC DETECTION LOGIC

To judge the malfunction, the diagnosis checks that the A/F signal computed by ECM from the A/F sensor 1 signal is not inordinately low.

DTC No.	Trouble diagnosis name	DTC detecting condition	Possible Cause
P0131	Air fuel ratio (A/F) sensor 1 circuit low voltage	<ul style="list-style-type: none"> The A/F signal computed by ECM from the A/F sensor 1 signal is constantly approx. 0 V. 	<ul style="list-style-type: none"> Harness or connectors (The A/F sensor 1 circuit is open or shorted.) A/F sensor 1

DTC CONFIRMATION PROCEDURE

1. PRECONDITIONING

If DTC Confirmation Procedure has been previously conducted, always turn ignition switch OFF and wait at least 10 seconds before conducting the next test.

TESTING CONDITION:

Before performing the following procedure, confirm that battery voltage is more than 10.5 V at idle.

>> GO TO 2.

2. CHECK A/F SENSOR FUNCTION

With CONSULT-III

- Start engine and warm it up to normal operating temperature.
- Select "A/F SEN1 (B1)" in "DATA MONITOR" mode with CONSULT-III.
- Check "A/F SEN1 (B1)" indication.

With GST

Follow the procedure "With CONSULT-III" above.

Is the indication constantly approx. 0 V?

P0131 A/F SENSOR 1

[MR18DE]

< DTC/CIRCUIT DIAGNOSIS >

- YES >> Go to [EC-170. "Diagnosis Procedure"](#).
NO >> GO TO 3.

3.PERFORM DTC CONFIRMATION PROCEDURE

With CONSULT-III

1. Turn ignition switch OFF, wait at least 10 seconds and then restart engine.
2. Drive and accelerate vehicle to more than 40 km/h (25 MPH) within 20 seconds after restarting engine.

CAUTION:

Always drive vehicle at a safe speed.

3. Maintain the following conditions for about 20 consecutive seconds.

ENG SPEED	1,000 - 3,200 rpm
VHCL SPEED SE	More than 40 km/h (25 mph)
B/FUEL SCHDL	1.5 - 9.0 msec
Selector lever	Suitable position

NOTE:

- Keep the accelerator pedal as steady as possible during the cruising.
- If this procedure is not completed within 1 minute after restarting engine at step 1, return to step 1.

4. Check 1st trip DTC.

With GST

Follow the procedure "With CONSULT-III" above.

Is 1st trip DTC detected?

- YES >> Go to [EC-170. "Diagnosis Procedure"](#).
NO >> INSPECTION END

Diagnosis Procedure

INFOID:000000004833279

1.CHECK GROUND CONNECTION

1. Turn ignition switch OFF.
2. Check ground connection E38. Refer to [GI-37. "Circuit Inspection"](#).

Is the inspection result normal?

- YES >> GO TO 2.
NO >> Repair or replace ground connection.

2.CHECK AIR FUEL RATIO (A/F) SENSOR 1 POWER SUPPLY CIRCUIT

1. Disconnect A/F sensor 1 harness connector.
2. Turn ignition switch ON.
3. Check the voltage between A/F sensor 1 harness connector and ground.

A/F sensor 1		Ground	Voltage
Connector	Terminal		
F50	4	Ground	Battery voltage

Is the inspection result normal?

- YES >> GO TO 4.
NO >> GO TO 3.

3.DETECT MALFUNCTIONING PART

Check the following.

- Harness connectors E8, F1
- IPDM E/R harness connector E15
- 15 A fuse (No. 61)
- Harness for open or short between A/F sensor 1 and fuse

>> Repair or replace harness or connectors.

P0131 A/F SENSOR 1

[MR18DE]

< DTC/CIRCUIT DIAGNOSIS >

4. CHECK A/F SENSOR 1 INPUT SIGNAL CIRCUIT FOR OPEN AND SHORT

1. Turn ignition switch OFF.
2. Disconnect ECM harness connector.
3. Check the continuity between A/F sensor 1 harness connector and ECM harness connector.

A/F sensor 1		ECM		Continuity
Connector	Terminal	Connector	Terminal	
F50	1	F8	49	Existed
	2		53	

4. Check the continuity between A/F sensor 1 harness connector and ground, or ECM harness connector and ground.

A/F sensor 1		Ground	Continuity
Connector	Terminal		
F50	1	Ground	Not existed
	2		

ECM		Ground	Continuity
Connector	Terminal		
F8	49	Ground	Not existed
	53		

5. Also check harness for short to power.

Is the inspection result normal?

YES >> GO TO 5.

NO >> Repair open circuit or short to ground or short to power in harness or connectors.

5. CHECK INTERMITTENT INCIDENT

Perform [GI-34. "Intermittent Incident"](#).

Is the inspection result normal?

YES >> GO TO 6.

NO >> Repair or replace.

6. REPLACE AIR FUEL RATIO (A/F) SENSOR 1

Replace air fuel ratio (A/F) sensor 1.

CAUTION:

- Discard any sensor which has been dropped from a height of more than 0.5 m (19.7 in) onto a hard surface such as a concrete floor; use a new one.
- Before installing new sensor, clean exhaust system threads using Oxygen Sensor Thread Cleaner [commercial service tool (J-43897-18 or J43897-12)] and approved Anti-seize Lubricant (commercial service tool).

>> INSPECTION END

P0132 A/F SENSOR 1

Description

INFOID:000000004833280

The air fuel ratio (A/F) sensor 1 is a planar one-cell limit current sensor. The sensor element of the A/F sensor 1 is composed an electrode layer, which transports ions. It has a heater in the element. The sensor is capable of precise measurement $\lambda = 1$, but also in the lean and rich range. Together with its control electronics, the sensor outputs a clear, continuous signal throughout a wide λ range. The exhaust gas components diffuse through the diffusion layer at the sensor cell. An electrode layer is applied voltage, and this current relative oxygen density in lean. Also this current relative hydrocarbon density in rich.

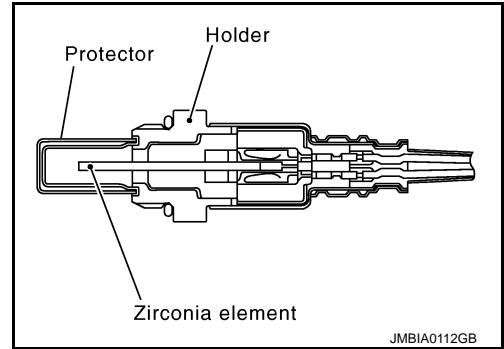

Therefore, the A/F sensor 1 is able to indicate air fuel ratio by this electrode layer of current. In addition, a heater is integrated in the sensor to ensure the required operating temperature of about 800°C (1,472°F).

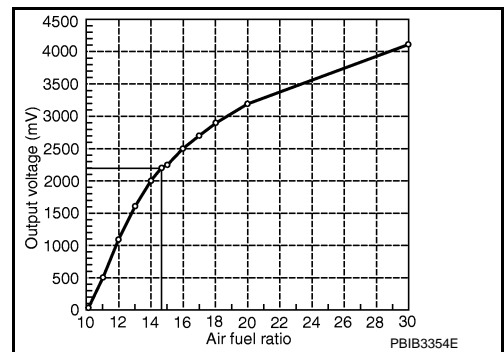

DTC Logic

INFOID:000000004833281

DTC DETECTION LOGIC

To judge the malfunction, the diagnosis checks that the A/F signal computed by ECM from the A/F sensor 1 signal is not inordinately high.

DTC No.	Trouble diagnosis name	DTC detecting condition	Possible Cause
P0132	Air fuel ratio (A/F) sensor 1 circuit high voltage	<ul style="list-style-type: none"> The A/F signal computed by ECM from the A/F sensor 1 signal is constantly approx. 5 V. 	<ul style="list-style-type: none"> Harness or connectors (The A/F sensor 1 circuit is open or shorted.) A/F sensor 1

DTC CONFIRMATION PROCEDURE

1. PRECONDITIONING

If DTC Confirmation Procedure has been previously conducted, always turn ignition switch OFF and wait at least 10 seconds before conducting the next test.

TESTING CONDITION:

Before performing the following procedure, confirm that battery voltage is more than 10.5 V at idle.

>> GO TO 2.

2. CHECK A/F SENSOR FUNCTION

With CONSULT-III

- Start engine and warm it up to normal operating temperature.
- Select "A/F SEN1 (B1)" in "DATA MONITOR" mode with CONSULT-III.
- Check "A/F SEN1 (B1)" indication.

With GST

Follow the procedure "With CONSULT-III" above.

Is the indication constantly approx. 5 V?

P0132 A/F SENSOR 1

[MR18DE]

< DTC/CIRCUIT DIAGNOSIS >

- YES >> Go to [EC-173. "Diagnosis Procedure"](#).
NO >> GO TO 3.

3.PERFORM DTC CONFIRMATION PROCEDURE

With CONSULT-III

1. Turn ignition switch OFF, wait at least 10 seconds and then restart engine.
2. Drive and accelerate vehicle to more than 40 km/h (25 MPH) within 20 seconds after restarting engine.

CAUTION:

Always drive vehicle at a safe speed.

3. Maintain the following conditions for about 20 consecutive seconds.

ENG SPEED	1,000 - 3,200 rpm
VHCL SPEED SE	More than 40 km/h (25 mph)
B/FUEL SCHDL	1.5 - 9.0 msec
Selector lever	Suitable position

NOTE:

- Keep the accelerator pedal as steady as possible during the cruising.
- If this procedure is not completed within 1 minute after restarting engine at step 1, return to step 1.

4. Check 1st trip DTC.

With GST

Follow the procedure "With CONSULT-III" above.

Is 1st trip DTC is detected?

- YES >> Go to [EC-173. "Diagnosis Procedure"](#).
NO >> INSPECTION END

Diagnosis Procedure

INFOID:000000004833283

1.CHECK GROUND CONNECTION

1. Turn ignition switch OFF.
2. Check ground connection E38. Refer to [GI-37. "Circuit Inspection"](#).

Is the inspection result normal?

- YES >> GO TO 2.
NO >> Repair or replace ground connection.

2.CHECK AIR FUEL RATIO (A/F) SENSOR 1 POWER SUPPLY CIRCUIT

1. Disconnect A/F sensor 1 harness connector.
2. Turn ignition switch ON.
3. Check the voltage between A/F sensor 1 harness connector and ground.

A/F sensor 1		Ground	Voltage
Connector	Terminal		
F50	4	Ground	Battery voltage

Is the inspection result normal?

- YES >> GO TO 4.
NO >> GO TO 3.

3.DETECT MALFUNCTIONING PART

Check the following.

- Harness connectors E8, F1
- IPDM E/R harness connector E15
- 15 A fuse (No. 61)
- Harness for open or short between A/F sensor 1 and fuse

>> Repair or replace harness or connectors.

P0132 A/F SENSOR 1

[MR18DE]

< DTC/CIRCUIT DIAGNOSIS >

4. CHECK A/F SENSOR 1 INPUT SIGNAL CIRCUIT FOR OPEN AND SHORT

1. Turn ignition switch OFF.
2. Disconnect ECM harness connector.
3. Check the continuity between A/F sensor 1 harness connector and ECM harness connector.

A/F sensor 1		ECM		Continuity
Connector	Terminal	Connector	Terminal	
F50	1	F8	49	Existed
	2		53	

4. Check the continuity between A/F sensor 1 harness connector and ground, or ECM harness connector and ground.

A/F sensor 1		Ground	Continuity
Connector	Terminal		
F50	1	Ground	Not existed
	2		

ECM		Ground	Continuity
Connector	Terminal		
F8	49	Ground	Not existed
	53		

5. Also check harness for short to power.

Is the inspection result normal?

YES >> GO TO 5.

NO >> Repair open circuit or short to ground or short to power in harness or connectors.

5. CHECK INTERMITTENT INCIDENT

Perform [GI-34. "Intermittent Incident"](#).

Is the inspection result normal?

YES >> GO TO 6.

NO >> Repair or replace.

6. REPLACE AIR FUEL RATIO (A/F) SENSOR 1

Replace air fuel ratio (A/F) sensor 1.

CAUTION:

- Discard any sensor which has been dropped from a height of more than 0.5 m (19.7 in) onto a hard surface such as a concrete floor; use a new one.
- Before installing new sensor, clean exhaust system threads using Oxygen Sensor Thread Cleaner [commercial service tool (J-43897-18 or J43897-12)] and approved Anti-seize Lubricant (commercial service tool).

>> INSPECTION END

P0133 A/F SENSOR 1

Description

INFOID:000000004833284

The air fuel ratio (A/F) sensor 1 is a planar one-cell limit current sensor. The sensor element of the A/F sensor 1 is composed an electrode layer, which transports ions. It has a heater in the element. The sensor is capable of precise measurement $\lambda = 1$, but also in the lean and rich range. Together with its control electronics, the sensor outputs a clear, continuous signal throughout a wide λ range. The exhaust gas components diffuse through the diffusion layer at the sensor cell. An electrode layer is applied voltage, and this current relative oxygen density in lean. Also this current relative hydrocarbon density in rich.

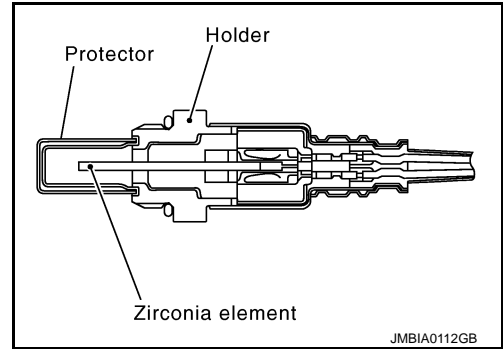

Therefore, the A/F sensor 1 is able to indicate air fuel ratio by this electrode layer of current. In addition, a heater is integrated in the sensor to ensure the required operating temperature of about 800°C (1,472°F).

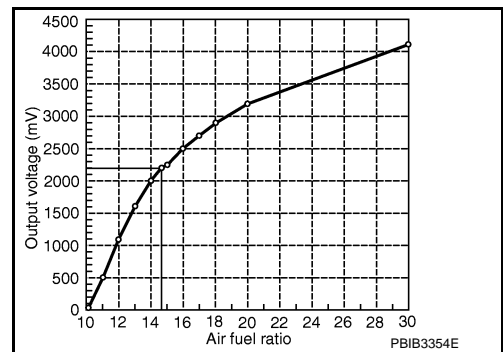

DTC Logic

INFOID:000000004833285

DTC DETECTION LOGIC

To judge the malfunction of A/F sensor 1, this diagnosis measures response time of the A/F signal computed by ECM from the A/F sensor 1 signal. The time is compensated by engine operating (speed and load), fuel feedback control constant, and the A/F sensor 1 temperature index. Judgment is based on whether the compensated time (the A/F signal cycling time index) is inordinately long or not.

DTC No.	Trouble diagnosis name	DTC detecting condition	Possible Cause
P0133	Air fuel ratio (A/F) sensor 1 circuit slow response	<ul style="list-style-type: none"> The response of the A/F signal computed by ECM from A/F sensor 1 signal takes more than the specified time. 	<ul style="list-style-type: none"> Harness or connectors (The A/F sensor 1 circuit is open or shorted.) A/F sensor 1 A/F sensor 1 heater Fuel pressure Fuel injector Intake air leaks Exhaust gas leaks PCV Mass air flow sensor

DTC CONFIRMATION PROCEDURE

1. PRECONDITIONING

If DTC Confirmation Procedure has been previously conducted, always turn ignition switch OFF and wait at least 10 seconds before conducting the next test.

TESTING CONDITION:

Before performing the following procedure, confirm that battery voltage is more than 11 V at idle.

Do you have CONSULT-III?

YES >> GO TO 2.

NO >> GO TO 5.

2. PERFORM DTC CONFIRMATION PROCEDURE-I

< DTC/CIRCUIT DIAGNOSIS >

ⓑ With CONSULT-III

1. Start engine and warm it up to normal operating temperature.
2. Turn ignition switch OFF and wait at least 10 seconds.
3. Start engine and keep the engine speed between 3,500 and 4,000 rpm for at least 1 minute under no load.
4. Let engine idle for 1 minute.
5. Select "A/F SEN1(B1) P1278/P1279" of "A/F SEN1" in "DTC WORK SUPPORT" mode with CONSULT-III.
6. Touch "START".

Is "COMPLETED" displayed on COUSULT-III?

- YES >> GO TO 3
 NO >> GO TO 4.

3. PERFORM DTC CONFIRMATION PROCEDURE-II

Touch "SELF-DIAG RESULT".

Which is displayed on CONSULT-III?

- OK >> INSPECTION END
 NG >> Go to [EC-177. "Diagnosis Procedure"](#).

4. PERFORM DTC CONFIRMATION PROCEDURE

1. After perform the following procedure, "TESTING" will be displayed on the CONSULT-III screen.
 - Increase the engine speed up to 4,000 to 5,000 rpm and keep it for 10 seconds.
 - Fully release accelerator pedal and then let engine idle for about 10 seconds.

If "TESTING" is not displayed after 10 seconds, go to [EC-109. "Component Function Check"](#).
2. Wait for about 20 seconds at idle under the condition that "TESTING" is displayed on the CONSULT-III screen.
3. Make sure that "TESTING" changes to "COMPLETED".
If "TESTING" changed to "OUT OF CONDITION", go to [EC-109. "Component Function Check"](#).
4. Touch "SELF-DIAG RESULT".

Which is displayed on CONSULT-III?

- OK >> INSPECTION END
 NG >> Go to [EC-177. "Diagnosis Procedure"](#).

5. CHECK AIR-FUEL RATIO SELF-LEARNING VALUE**ⓐ With GST**

1. Start engine and warm it up to normal operating temperature.
2. Select Service \$01 with GST.
3. Calculate the total value of "Short-term fuel trim" and "Long-term fuel trim" indications.

Is the total percentage within $\pm 15\%$?

- YES >> GO TO 7.
 NO >> GO TO 6.

6. DETECT MALFUNCTIONING PART

Check the following.

- Intake air leaks
- Exhaust gas leaks
- Incorrect fuel pressure
- Lack of fuel
- Fuel injector
- Incorrect PCV hose connection
- PCV valve
- Mass air flow sensor

>> Repair or replace malfunctioning part.

7. PERFORM DTC CONFIRMATION PROCEDURE

1. Turn ignition switch OFF and wait at least 10 seconds.
2. Start engine and keep the engine speed between 3,500 and 4,000 rpm for at least 1 minute under no load.
3. Let engine idle for 1 minute.
4. Increase the engine speed up to 4,000 to 5,000 rpm and keep it for 10 seconds.

P0133 A/F SENSOR 1

[MR18DE]

< DTC/CIRCUIT DIAGNOSIS >

5. Fully release accelerator pedal and then let engine idle for about 1 minute.
6. Check 1st trip DTC detected?.

Is 1st trip DTC detected?

- YES >> Go to [EC-177, "Diagnosis Procedure"](#).
NO >> INSPECTION END

Diagnosis Procedure

INFOID:000000004833287

1.CHECK GROUND CONNECTION

1. Turn ignition switch OFF.
2. Check ground connection E38. Refer to [GI-37, "Circuit Inspection"](#).

Is the inspection result normal?

- YES >> GO TO 2.
NO >> Repair or replace ground connection.

2.RETIGHTEN A/F SENSOR 1

Loosen and retighten the A/F sensor 1. Refer to [EM-29, "Exploded View"](#).

>> GO TO 3.

3.CHECK EXHAUST GAS LEAK

1. Start engine and run it at idle.
2. Listen for an exhaust gas leak before three way catalyst (manifold).

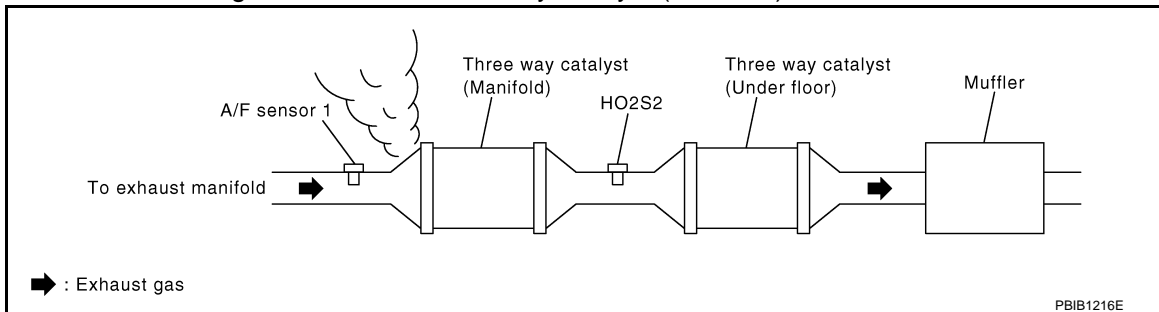

Is exhaust gas leak detected?

- YES >> Repair or replace.
NO >> GO TO 4.

4.CHECK FOR INTAKE AIR LEAK

Listen for an intake air leak after the mass air flow sensor.

Is intake air leak detected?

- YES >> Repair or replace.
NO >> GO TO 5.

5.CLEAR THE MIXTURE RATIO SELF-LEARNING VALUE

1. Clear the mixture ratio self-learning value. Refer to [EC-19, "MIXTURE RATIO SELF-LEARNING VALUE CLEAR : Special Repair Requirement"](#).
2. Run engine for at least 10 minutes at idle speed.

Is the 1st trip DTC P0171 or P172 detected? Is it difficult to start engine?

- YES >> Perform trouble diagnosis for DTC P0171 or P0172. Refer to [EC-200, "DTC Logic"](#) or [EC-204, "DTC Logic"](#).
NO >> GO TO 6.

6.CHECK AIR FUEL RATIO (A/F) SENSOR 1 POWER SUPPLY CIRCUIT

1. Disconnect A/F sensor 1 harness connector.
2. Turn ignition switch ON.
3. Check the voltage between A/F sensor 1 harness connector and ground.

< DTC/CIRCUIT DIAGNOSIS >

A/F sensor 1		Ground	Voltage
Connector	Terminal		
F50	4	Ground	Battery voltage

Is the inspection result normal?

- YES >> GO TO 8.
- NO >> GO TO 7.

7.DETECT MALFUNCTIONING PART

Check the following.

- Harness connectors E8, F1
- IPDM E/R harness connector E15
- 15 A fuse (No. 61)
- Harness for open or short between A/F sensor 1 and fuse

>> Repair or replace harness or connectors.

8.CHECK A/F SENSOR 1 INPUT SIGNAL CIRCUIT FOR OPEN AND SHORT

1. Turn ignition switch OFF.
2. Disconnect ECM harness connector.
3. Check the continuity between A/F sensor 1 harness connector and ECM harness connector.

A/F sensor 1		ECM		Continuity
Connector	Terminal	Connector	Terminal	
F50	1	F8	49	Existed
	2		53	

4. Check the continuity between A/F sensor 1 harness connector and ground, or ECM harness connector and ground.

A/F sensor 1		Ground	Continuity
Connector	Terminal		
F50	1	Ground	Not existed
	2		

ECM		Ground	Continuity
Connector	Terminal		
F8	49	Ground	Not existed
	53		

5. Also check harness for short to power.

Is the inspection result normal?

- YES >> GO TO 9.
- NO >> Repair open circuit or short to ground or short to power in harness or connectors.

9.CHECK AIR FUEL RATIO (A/F) SENSOR 1 HEATER

Refer to [EC-129, "Component Inspection"](#).

Is the inspection result normal?

- YES >> GO TO 10.
- NO >> GO TO 13.

10.CHECK MASS AIR FLOW SENSOR

Refer to [EC-139, "Component Inspection"](#).

Is the inspection result normal?

P0133 A/F SENSOR 1

[MR18DE]

< DTC/CIRCUIT DIAGNOSIS >

- YES >> GO TO 11.
NO >> Replace mass air flow sensor.

11.CHECK PCV VALVE

Refer to [EC-413. "Component Inspection"](#).

Is the inspection result normal?

- YES >> GO TO 12.
NO >> Repair or replace PCV valve.

12.CHECK INTERMITTENT INCIDENT

Perform [GI-34. "Intermittent Incident"](#).

Is the inspection result normal?

- YES >> GO TO 13.
NO >> Repair or replace.

13.REPLACE AIR FUEL RATIO (A/F) SENSOR 1

Replace air fuel ratio (A/F) sensor 1.

CAUTION:

- Discard any sensor which has been dropped from a height of more than 0.5 m (19.7 in) onto a hard surface such as a concrete floor; use a new one.
- Before installing new sensor, clean exhaust system threads using Oxygen Sensor Thread Cleaner [commercial service tool (J-43897-18 or J43897-12)] and approved Anti-seize Lubricant (commercial service tool).

>> INSPECTION END

A
EC
C
D
E
F
G
H
I
J
K
L
M
N
O
P

P0137 HO2S2

Description

INFOID:000000004833288

The heated oxygen sensor 2, after three way catalyst (manifold), monitors the oxygen level in the exhaust gas on each bank. Even if switching characteristics of the air fuel ratio (A/F) sensor 1 are shifted, the air-fuel ratio is controlled to stoichiometric, by the signal from the heated oxygen sensor 2. This sensor is made of ceramic zirconia. The zirconia generates voltage from approximately 1 V in richer conditions to 0 V in leaner conditions. Under normal conditions the heated oxygen sensor 2 is not used for engine control operation.

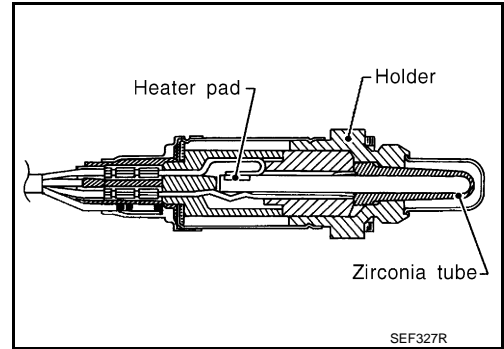

DTC Logic

INFOID:000000004833289

DTC DETECTION LOGIC

The heated oxygen sensor 2 has a much longer switching time between rich and lean than the air fuel ratio (A/F) sensor 1. The oxygen storage capacity of the three way catalyst (manifold) causes the longer switching time. To judge the malfunctions of heated oxygen sensor 2, ECM monitors whether the maximum voltage of the sensor is sufficiently high during the various driving condition such as fuel-cut.

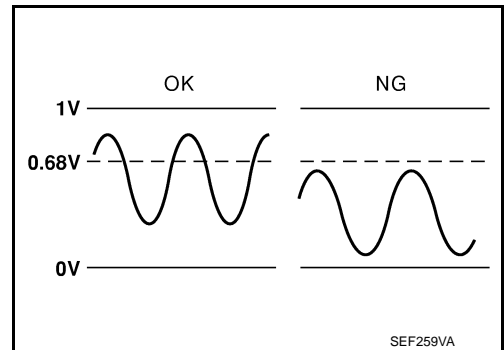

DTC No.	Trouble diagnosis name	DTC detecting condition	Possible cause
P0137	Heated oxygen sensor 2 circuit low voltage	The maximum voltage from the sensor is not reached to the specified voltage.	<ul style="list-style-type: none"> • Harness or connectors (The sensor circuit is open or shorted) • Heated oxygen sensor 2 • Fuel pressure • Fuel injector • Intake air leaks

DTC CONFIRMATION PROCEDURE

1.INSPECTION START

Do you have CONSULT-III?

Do you have CONSULT-III?

YES >> GO TO 2.

NO >> GO TO 5.

2.PRECONDITIONING

If DTC confirmation Procedure has been previously conducted, always turn ignition switch OFF and wait at least 10 seconds before conducting the next test.

TESTING CONDITION:

For better results, perform "DTC WORK SUPPORT" at a temperature of 0 to 30°C (32 to 86°F).

>> GO TO 3.

3.PERFORM DTC CONFIRMATION PROCEDURE

With CONSULT-III

< DTC/CIRCUIT DIAGNOSIS >

1. Turn ignition switch ON and select "DATA MONITOR" mode with CONSULT-III.
2. Start engine and warm it up to normal operating temperature.
3. Turn ignition switch OFF and wait at least 10 seconds.
4. Start engine and keep the engine speed between 3,500 and 4,000 rpm for at least 1 minute under no load.
5. Let engine idle for 1 minute.
6. Make sure that "COOLAN TEMP/S" indicates more than 70°C (158°F).
If not, warm up engine and go to next step when "COOLAN TEMP/S" indication reaches 70°C (158°F).
7. Open engine hood.
8. Select "HO2S2 (B1) P1147" of "HO2S2" in "DTC WORK SUPPORT" mode with CONSULT-III.
9. Follow the instruction of CONSULT-III.

NOTE:

It will take at most 10 minutes until "COMPLETED" is displayed.

10. Touch "SELF-DIAG RESULT".

Which is displayed on CONSULT-III screen?

- OK >> INSPECTION END
- NG >> Go to [EC-182. "Diagnosis Procedure"](#).
- CAN NOT BE DIAGNOSED>>GO TO 4.

4.PERFORM DTC CONFIRMATION PROCEDURE AGAIN

1. Turn ignition switch OFF and leave the vehicle in a cool place (soak the vehicle).
2. Perform DTC CONFIRMATION PROCEDURE again.

>> GO TO 3.

5.PERFORM COMPONENT FUNCTION CHECK

Perform component function check. Refer to [EC-181. "Component Function Check"](#).

NOTE:

Use component function check to check the overall function of the heated oxygen sensor 2 circuit. During this check, a 1st trip DTC might not be confirmed.

Is the inspection result normal?

- YES >> INSPECTION END
- NO >> Go to [EC-182. "Diagnosis Procedure"](#).

Component Function Check

INFOID:000000004833290

1.PERFORM COMPONENT FUNCTION CHECK-I

⊗ Without CONSULT-III

1. Start engine and warm it up to normal operating temperature.
2. Turn ignition switch OFF and wait at least 10 seconds.
3. Start engine and keep the engine speed between 3,500 and 4,000 rpm for at least 1 minute under no load.
4. Let engine idle for 1 minute.
5. Check the voltage between ECM harness connector and ground under the following condition.

ECM		Ground	Condition	Voltage
Connector	Terminal			
F8	50 (HO2S2 signal)	Ground	Reving up to 4,000 rpm under no load at least 10 times	The voltage should be above 0.68 V at least once during this procedure.

Is the inspection result normal?

- YES >> INSPECTION END
- NO >> GO TO 2.

2.PERFORM COMPONENT FUNCTION CHECK-II

Check the voltage between ECM harness connector and ground under the following condition.

< DTC/CIRCUIT DIAGNOSIS >

ECM		Ground	Condition	Voltage
Connector	Terminal			
F8	50 (HO2S2 signal)	Ground	Keeping engine speed at idle for 10 minutes	The voltage should be above 0.68 V at least once during this procedure.

Is the inspection result normal?

YES >> INSPECTION END

NO >> GO TO 3.

3.PERFORM COMPONENT FUNCTION CHECK-III

Check the voltage between ECM harness connector and ground under the following condition.

ECM		Ground	Condition	Voltage
Connector	Terminal			
F8	50 (HO2S2 signal)	Ground	Coasting from 80 km/h (50 MPH) in D position (CVT), 4th gear position (M/T)	The voltage should be above 0.68 V at least once during this procedure.

Is the inspection result normal?

YES >> INSPECTION END

NO >> Go to [EC-182, "Diagnosis Procedure"](#).

Diagnosis Procedure

INFOID:000000004833292

1.CHECK GROUND CONNECTION

1. Turn ignition switch OFF.
2. Check ground connection E38. Refer to [GI-37, "Circuit Inspection"](#).

Is the inspection result normal?

YES >> GO TO 2.

NO >> Repair or replace ground connection.

2.CLEAR THE MIXTURE RATIO SELF-LEARNING VALUE

1. Clear the mixture ratio self-learning value. Refer to [EC-19, "MIXTURE RATIO SELF-LEARNING VALUE CLEAR : Special Repair Requirement"](#).
2. Run engine for at least 10 minutes at idle speed.

Is the 1st trip DTC P0171 detected? Is it difficult to start engine?

YES >> Perform trouble diagnosis for DTC P0171. Refer to [EC-200, "DTC Logic"](#).

NO >> GO TO 3.

3.CHECK HO2S2 GROUND CIRCUIT FOR OPEN AND SHORT

1. Turn ignition switch OFF.
2. Disconnect heated oxygen sensor 2 (HO2S2) harness connector.
3. Disconnect ECM harness connector.
4. Check the continuity between HO2S2 harness connector and ECM harness connector.

HO2S2		ECM		Continuity
Connector	Terminal	Connector	Terminal	
F30	1	F8	59	Existed

5. Also check harness for short to ground and short to power.

Is the inspection result normal?

YES >> GO TO 4.

NO >> Repair open circuit or short to ground or short to power in harness or connectors.

4.CHECK HO2S2 INPUT SIGNAL CIRCUIT FOR OPEN AND SHORT

1. Check the continuity between HO2S2 harness connector and ECM harness connector.

< DTC/CIRCUIT DIAGNOSIS >

HO2S2		ECM		Continuity
Connector	Terminal	Connector	Terminal	
F30	4	F8	50	Existed

2. Check the continuity between HO2S2 harness connector and ground, or ECM harness connector and ground.

HO2S2		Ground	Continuity
Connector	Terminal		
F30	4	Ground	Not existed

ECM		Ground	Continuity
Connector	Terminal		
F8	50	Ground	Not existed

3. Also check harness for short to power.

Is the inspection result normal?

YES >> GO TO 5.

NO >> Repair open circuit or short to ground or short to power in harness or connectors.

5.CHECK HEATED OXYGEN SENSOR 2

Refer to [EC-183. "Component Inspection"](#).

Is the inspection result normal?

YES >> GO TO 7.

NO >> GO TO 6.

6.REPLACE HEATED OXYGEN SENSOR 2

Replace heated oxygen sensor 2.

CAUTION:

- Discard any sensor which has been dropped from a height of more than 0.5 m (19.7 in) onto a hard surface such as a concrete floor; use a new one.
- Before installing new sensor, clean exhaust system threads using Oxygen Sensor Thread Cleaner [commercial service tool (J-43897-18 or J43897-12)] and approved Anti-seize Lubricant (commercial service tool).

>> INSPECTION END

7.CHECK INTERMITTENT INCIDENT

Refer to [GI-34. "Intermittent Incident"](#).

>> INSPECTION END

Component Inspection

INFOID:000000004833293

1.INSPECTION START

Do you have CONSULT-III?

Do you have CONSULT-III?

YES >> GO TO 2.

NO >> GO TO 3.

2.CHECK HEATED OXYGEN SENSOR 2

Ⓜ With CONSULT-III

1. Turn ignition switch ON and select "DATA MONITOR" mode with CONSULT-III.
2. Start engine and warm it up to normal operating temperature.
3. Turn ignition switch OFF and wait at least 10 seconds.

< DTC/CIRCUIT DIAGNOSIS >

4. Start engine and keep the engine speed between 3,500 and 4,000 rpm for at least 1 minute under no load.
5. Let engine idle for 1 minute.
6. Select "FUEL INJECTION" in "ACTIVE TEST" mode, and select "HO2S2 (B1)" as the monitor item with CONSULT-III.
7. Check "HO2S2 (B1)" at idle speed when adjusting "FUEL INJECTION" to $\pm 25\%$.

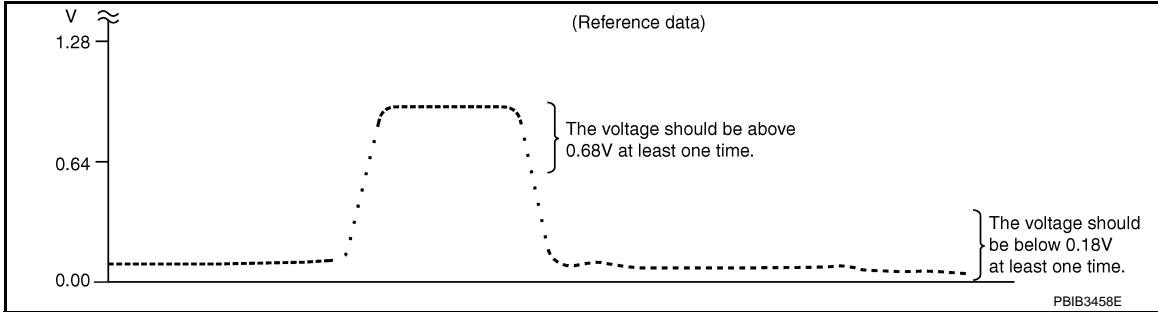

"HO2S2 (B1)" should be above 0.68 V at least once when the "FUEL INJECTION" is + 25%.
 "HO2S2 (B1)" should be below 0.18 V at least once when the "FUEL INJECTION" is - 25%.

Is the inspection result normal?

- YES >> INSPECTION END
- NO >> GO TO 6.

3.CHECK HEATED OXYGEN SENSOR 2-I

⊗ Without CONSULT-III

1. Start engine and warm it up to normal operating temperature.
2. Turn ignition switch OFF and wait at least 10 seconds.
3. Start engine and keep the engine speed between 3,500 and 4,000 rpm for at least 1 minute under no load.
4. Let engine idle for 1 minute.
5. Check the voltage between ECM harness connector and ground under the following condition.

ECM		Ground	Condition	Voltage
Connector	Terminal			
F8	50 (HO2S2 signal)	Ground	Revvng up to 4,000 rpm under no load at least 10 times	The voltage should be above 0.68 V at least once during this procedure. The voltage should be below 0.18 V at least once during this procedure.

Is the inspection result normal?

- YES >> INSPECTION END
- NO >> GO TO 4.

4.CHECK HEATED OXYGEN SENSOR 2-II

Check the voltage between ECM harness connector and ground under the following condition.

ECM		Ground	Condition	Voltage
Connector	Terminal			
F8	50 (HO2S2 signal)	Ground	Keeping engine speed at idle for 10 minutes	The voltage should be above 0.68 V at least once during this procedure. The voltage should be below 0.18 V at least once during this procedure.

Is the inspection result normal?

- YES >> INSPECTION END
- NO >> GO TO 5.

5.CHECK HEATED OXYGEN SENSOR 2-III

Check the voltage between ECM harness connector and ground under the following condition.

ECM		Ground	Condition	Voltage
Connector	Terminal			
F8	50 (HO2S2 signal)	Ground	Coasting from 80 km/h (50 MPH) in D position (CVT), 4th gear position (M/T)	The voltage should be above 0.68 V at least once during this procedure. The voltage should be below 0.18 V at least once during this procedure.

A
EC

Is the inspection result normal?

- YES >> INSPECTION END
- NO >> GO TO 6.

C

6.REPLACE HEATED OXYGEN SENSOR 2

D

Replace heated oxygen sensor 2.

CAUTION:

- Discard any sensor which has been dropped from a height of more than 0.5 m (19.7 in) onto a hard surface such as a concrete floor; use a new one.
- Before installing new sensor, clean exhaust system threads using Oxygen Sensor Thread Cleaner [commercial service tool (J-43897-18 or J43897-12)] and approved Anti-seize Lubricant (commercial service tool).

E

F

>> INSPECTION END

G

H

I

J

K

L

M

N

O

P

P0138 HO2S2

Description

INFOID:000000004833294

The heated oxygen sensor 2, after three way catalyst (manifold), monitors the oxygen level in the exhaust gas on each bank. Even if switching characteristics of the air fuel ratio (A/F) sensor 1 are shifted, the air-fuel ratio is controlled to stoichiometric, by the signal from the heated oxygen sensor 2. This sensor is made of ceramic zirconia. The zirconia generates voltage from approximately 1 V in richer conditions to 0 V in leaner conditions. Under normal conditions the heated oxygen sensor 2 is not used for engine control operation.

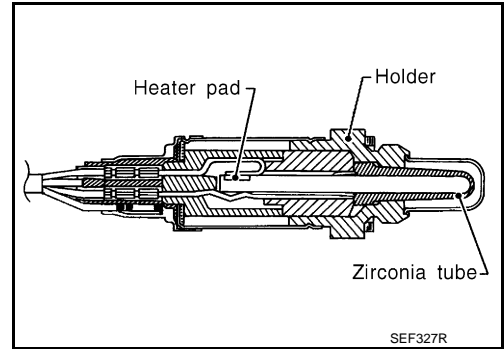

DTC Logic

INFOID:000000004833295

DTC DETECTION LOGIC

The heated oxygen sensor 2 has a much longer switching time between rich and lean than the air fuel ratio (A/F) sensor 1. The oxygen storage capacity of the three way catalyst (manifold) causes the longer switching time.

MALFUNCTION A

To judge the malfunctions of heated oxygen sensor 2, ECM monitors whether the voltage is unusually high during the various driving condition such as fuel-cut.

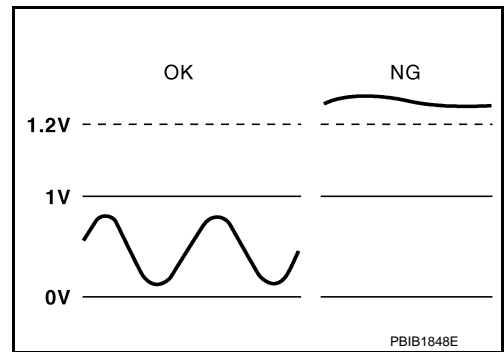

MALFUNCTION B

To judge the malfunctions of heated oxygen sensor 2, ECM monitors whether the minimum voltage of sensor is sufficiently low during the various driving condition such as fuel-cut.

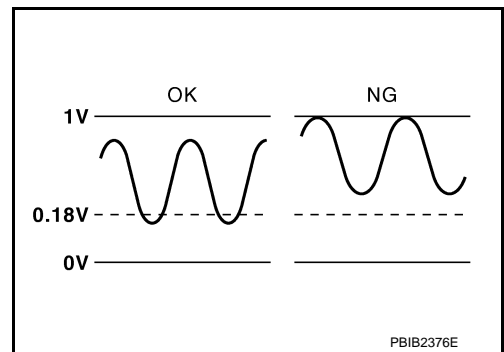

DTC No.	Trouble diagnosis name	DTC detecting condition		Possible cause
P0138	Heated oxygen sensor 2 circuit high voltage	A)	An excessively high voltage from the sensor is sent to ECM.	<ul style="list-style-type: none"> • Harness or connectors (The sensor circuit is open or shorted) • Heated oxygen sensor 2
		B)	The minimum voltage from the sensor is not reached to the specified voltage.	<ul style="list-style-type: none"> • Harness or connectors (The sensor circuit is open or shorted) • Heated oxygen sensor 2 • Fuel pressure • Fuel injector

< DTC/CIRCUIT DIAGNOSIS >

DTC CONFIRMATION PROCEDURE

1. PRECONDITIONING

If DTC Confirmation Procedure has been previously conducted, always turn ignition switch OFF and wait at least 10 seconds before conducting the next test.

>> GO TO 2.

2. PERFORM DTC CONFIRMATION PROCEDURE FOR MALFUNCTION A

1. Start engine and warm it up to normal operating temperature.
2. Turn ignition switch OFF and wait at least 10 seconds.
3. Start engine and keep the engine speed between 3,500 and 4,000 rpm for at least 1 minute under no load.
4. Let engine idle for 2 minutes.
5. Check 1st trip DTC.

Is 1st trip DTC detected?

- YES >> Go to [EC-188, "Diagnosis Procedure"](#).
 NO-1 >> With CONSULT-III: GO TO 3.
 NO-2 >> Without CONSULT-III: GO TO 5.

3. PERFORM DTC CONFIRMATION PROCEDURE FOR MALFUNCTION B**NOTE:**

For better results, perform "DTC WORK SUPPORT" at a temperature of 0 to 30°C (32 to 86°F).

1. Turn ignition switch ON and select "DATA MONITOR" mode with CONSULT-III.
2. Start engine and warm it up to normal operating temperature.
3. Turn ignition switch OFF and wait at least 10 seconds.
4. Start engine and keep the engine speed between 3,500 and 4,000 rpm for at least 1 minute under no load.
5. Let engine idle for 1 minute.
6. Make sure that "COOLAN TEMP/S" indication is more than 70°C (158°F).
If not, warm up engine and go to next step when "COOLAN TEMP/S" indication reaches 70°C (158°F).
7. Open engine hood.
8. Select "HO2S2 (B1) P1146" of "HO2S2" in "DTC WORK SUPPORT" mode with CONSULT-III.
9. Follow the instruction of CONSULT-III.

NOTE:

It will take at most 10 minutes until "COMPLETED" is displayed.

10. Touch "SELF-DIAG RESULT".

Which is displayed on CONSULT-III

- OK >> INSPECTION END
 NG >> Go to [EC-188, "Diagnosis Procedure"](#).
 CAN NOT BE DIAGNOSED >> GO TO 4.

4. PERFORM DTC CONFIRMATION PROCEDURE FOR MALFUNCTION B AGAIN

1. Turn ignition switch OFF and leave the vehicle in a cool place (soak the vehicle).
2. Perform DTC CONFIRMATION PROCEDURE again.

>> GO TO 3.

5. PERFORM COMPONENT FUNCTION CHECK FOR MALFUNCTION B

Perform component function check. Refer to [EC-188, "Diagnosis Procedure"](#).

NOTE:

Use component function check to check the overall function of the heated oxygen sensor 2 circuit. During this check, a 1st trip DTC might not be confirmed.

Is the inspection result normal?

- YES >> INSPECTION END
 NO >> Go to [EC-188, "Diagnosis Procedure"](#).

Component Function Check

INFOID:000000004833296

1. PERFORM COMPONENT FUNCTION CHECK-I

< DTC/CIRCUIT DIAGNOSIS >

⊗ Without CONSULT-III

1. Start engine and warm it up to normal operating temperature.
2. Turn ignition switch OFF and wait at least 10 seconds.
3. Start engine and keep the engine speed between 3,500 and 4,000 rpm for at least 1 minute under no load.
4. Let engine idle for 1 minute.
5. Check the voltage between ECM harness connector and ground under the following condition.

ECM		Ground	Condition	Voltage
Connector	Terminal			
F8	50 (HO2S2 signal)	Ground	Revvng up to 4,000 rpm under no load at least 10 times	The voltage should be above 0.18 V at least once during this procedure.

Is the inspection result normal?

YES >> INSPECTION END

NO >> GO TO 2.

2.PERFORM COMPONENT FUNCTION CHECK-II

Check the voltage between ECM harness connector and ground under the following condition.

ECM		Ground	Condition	Voltage
Connector	Terminal			
F8	50 (HO2S2 signal)	Ground	Keeping engine speed at idle for 10 minutes	The voltage should be above 0.18 V at least once during this procedure.

Is the inspection result normal?

YES >> INSPECTION END

NO >> GO TO 3.

3.PERFORM COMPONENT FUNCTION CHECK-III

Check the voltage between ECM harness connector and ground under the following condition.

ECM		Ground	Condition	Voltage
Connector	Terminal			
F8	50 (HO2S2 signal)	Ground	Coasting from 80 km/h (50 MPH) in D position (CVT), 4th gear position (M/T)	The voltage should be above 0.18 V at least once during this procedure.

Is the inspection result normal?

YES >> INSPECTION END

NO >> Go to [EC-188. "Diagnosis Procedure"](#).

Diagnosis Procedure

INFOID:000000004833298

1.INSPECTION START

Confirm the detected malfunction (A or B). Refer to [EC-186. "DTC Logic"](#).

Which malfunction is detected?

A >> GO TO 2.

B >> GO TO 9.

2.CHECK GROUND CONNECTION

1. Turn ignition switch OFF.
2. Check ground connection E38. Refer to [GI-37. "Circuit Inspection"](#).

Is the inspection result normal?

YES >> GO TO 3.

NO >> Repair or replace ground connection.

3.CHECK HO2S2 CONNECTOR FOR WATER

< DTC/CIRCUIT DIAGNOSIS >

1. Disconnect heated oxygen sensor 2 harness connector.
2. Check connectors for water.

Water should not exist.

Is the inspection result normal?

YES >> GO TO 4.

NO >> Repair or replace harness or connectors.

4.CHECK HO2S2 GROUND CIRCUIT FOR OPEN AND SHORT

1. Disconnect ECM harness connector.
2. Check the continuity between HO2S2 harness connector and ECM harness connector.

HO2S2		ECM		Continuity
Connector	Terminal	Connector	Terminal	
F30	1	F8	59	Existed

3. Also check harness for short to ground and short to power.

Is the inspection result normal?

YES >> GO TO 5.

NO >> Repair open circuit or short to ground or short to power in harness or connectors.

5.CHECK HO2S2 INPUT SIGNAL CIRCUIT FOR OPEN AND SHORT

1. Check the continuity between HO2S2 harness connector and ECM harness connector.

HO2S2		ECM		Continuity
Connector	Terminal	Connector	Terminal	
F30	4	F8	50	Existed

2. Check the continuity between HO2S2 harness connector and ground, or ECM harness connector and ground.

HO2S2		Ground	Continuity
Connector	Terminal		
F30	4	Ground	Not existed

ECM		Ground	Continuity
Connector	Terminal		
F8	50	Ground	Not existed

3. Also check harness for short to power.

Is the inspection result normal?

YES >> GO TO 6.

NO >> Repair open circuit or short to ground or short to power in harness or connectors.

6.CHECK HEATED OXYGEN SENSOR 2

Refer to [EC-191, "Component Inspection"](#).

Is the inspection result normal?

YES >> GO TO 8.

NO >> GO TO 7.

7.REPLACE HEATED OXYGEN SENSOR 2

Replace heated oxygen sensor 2.

CAUTION:

- Discard any sensor which has been dropped from a height of more than 0.5 m (19.7 in) onto a hard surface such as a concrete floor; use a new one.

< DTC/CIRCUIT DIAGNOSIS >

- Before installing new sensor, clean exhaust system threads using Oxygen Sensor Thread Cleaner [commercial service tool (J-43897-18 or J43897-12)] and approved Anti-seize Lubricant (commercial service tool).

>> INSPECTION END

8.CHECK INTERMITTENT INCIDENT

Refer to [GI-34, "Intermittent Incident"](#).

>> INSPECTION END

9.CHECK GROUND CONNECTION

1. Turn ignition switch OFF.
2. Check ground connection E38. Refer to [GI-37, "Circuit Inspection"](#).

Is the inspection result normal?

- YES >> GO TO 10.
- NO >> Repair or replace ground connection.

10.CLEAR THE MIXTURE RATIO SELF-LEARNING VALUE

1. Clear the mixture ratio self-learning value. Refer to [EC-19, "MIXTURE RATIO SELF-LEARNING VALUE CLEAR : Special Repair Requirement"](#).
2. Run engine for at least 10 minutes at idle speed.

Is the 1st trip DTC P0172 detected? Is it difficult to start engine?

- YES >> Perform trouble diagnosis for DTC P0172. Refer to [EC-204, "DTC Logic"](#).
- NO >> GO TO 11.

11.CHECK HO2S2 GROUND CIRCUIT FOR OPEN AND SHORT

1. Turn ignition switch OFF.
2. Disconnect heated oxygen sensor 2 harness connector.
3. Disconnect ECM harness connector.
4. Check the continuity between HO2S2 harness connector and ECM harness connector.

HO2S2		ECM		Continuity
Connector	Terminal	Connector	Terminal	
F30	1	F8	59	Existed

5. Also check harness for short to ground and short to power.

Is the inspection result normal?

- YES >> GO TO 12.
- NO >> Repair open circuit or short to ground or short to power in harness or connectors.

12.CHECK HO2S2 INPUT SIGNAL CIRCUIT FOR OPEN AND SHORT

1. Check the continuity between HO2S2 harness connector and ECM harness connector.

HO2S2		ECM		Continuity
Connector	Terminal	Connector	Terminal	
F30	4	F8	50	Existed

2. Check the continuity between HO2S2 harness connector or ECM harness connector and ground.

HO2S2		Ground	Continuity
Connector	Terminal		
F30	4	Ground	Not existed

ECM		Ground	Continuity
Connector	Terminal		
F8	50	Ground	Not existed

3. Also check harness for short to power.

Is the inspection result normal?

YES >> GO TO 13.

NO >> Repair open circuit or short to ground or short to power in harness or connectors.

13.CHECK HEATED OXYGEN SENSOR 2

Refer to [EC-191, "Component Inspection"](#).

Is the inspection result normal?

YES >> GO TO 15.

NO >> GO TO 14.

14.REPLACE HEATED OXYGEN SENSOR 2

Replace heated oxygen sensor 2.

CAUTION:

- Discard any sensor which has been dropped from a height of more than 0.5 m (19.7 in) onto a hard surface such as a concrete floor; use a new one.
- Before installing new sensor, clean exhaust system threads using Oxygen Sensor Thread Cleaner [commercial service tool (J-43897-18 or J43897-12)] and approved Anti-seize Lubricant (commercial service tool).

>> INSPECTION END

15.CHECK INTERMITTENT INCIDENT

Refer to [GI-34, "Intermittent Incident"](#).

>> INSPECTION END

Component Inspection

INFOID:000000004833299

1.INSPECTION START

Do you have CONSULT-III?

Do you have CONSULT-III?

YES >> GO TO 2.

NO >> GO TO 3.

2.CHECK HEATED OXYGEN SENSOR 2

 **With CONSULT-III**

1. Turn ignition switch ON and select "DATA MONITOR" mode with CONSULT-III.
2. Start engine and warm it up to normal operating temperature.
3. Turn ignition switch OFF and wait at least 10 seconds.
4. Start engine and keep the engine speed between 3,500 and 4,000 rpm for at least 1 minute under no load.
5. Let engine idle for 1 minute.
6. Select "FUEL INJECTION" in "ACTIVE TEST" mode, and select "HO2S2 (B1)" as the monitor item with CONSULT-III.

A
EC
C
D
E
F
G
H
I
J
K
L
M
N
O
P

< DTC/CIRCUIT DIAGNOSIS >

7. Check "HO2S2 (B1)" at idle speed when adjusting "FUEL INJECTION" to $\pm 25\%$.

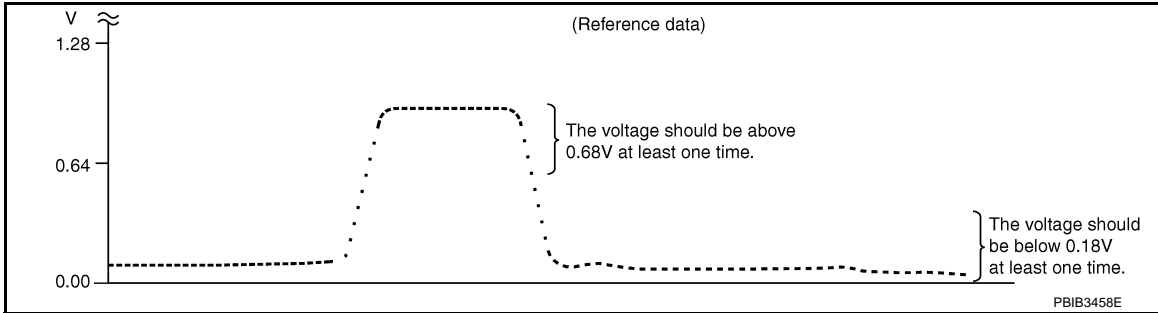

"HO2S2 (B1)" should be above 0.68 V at least once when the "FUEL INJECTION" is + 25%.
 "HO2S2 (B1)" should be below 0.18 V at least once when the "FUEL INJECTION" is - 25%.

Is the inspection result normal?

- YES >> INSPECTION END
- NO >> GO TO 6.

3.CHECK HEATED OXYGEN SENSOR 2-I

⊗ Without CONSULT-III

1. Start engine and warm it up to normal operating temperature.
2. Turn ignition switch OFF and wait at least 10 seconds.
3. Start engine and keep the engine speed between 3,500 and 4,000 rpm for at least 1 minute under no load.
4. Let engine idle for 1 minute.
5. Check the voltage between ECM harness connector and ground under the following condition.

ECM		Ground	Condition	Voltage
Connector	Terminal			
F8	50 (HO2S2 signal)	Ground	Revvng up to 4,000 rpm under no load at least 10 times	The voltage should be above 0.68 V at least once during this procedure. The voltage should be below 0.18 V at least once during this procedure.

Is the inspection result normal?

- YES >> INSPECTION END
- NO >> GO TO 4.

4.CHECK HEATED OXYGEN SENSOR 2-II

Check the voltage between ECM harness connector and ground under the following condition.

ECM		Ground	Condition	Voltage
Connector	Terminal			
F8	50 (HO2S2 signal)	Ground	Keeping engine speed at idle for 10 minutes	The voltage should be above 0.68 V at least once during this procedure. The voltage should be below 0.18 V at least once during this procedure.

Is the inspection result normal?

- YES >> INSPECTION END
- NO >> GO TO 5.

5.CHECK HEATED OXYGEN SENSOR 2-III

Check the voltage between ECM harness connector and ground under the following condition.

ECM		Ground	Condition	Voltage
Connector	Terminal			
F8	50 (HO2S2 signal)	Ground	Coasting from 80 km/h (50 MPH) in D position (CVT), 4th gear position (M/T)	The voltage should be above 0.68 V at least once during this procedure. The voltage should be below 0.18 V at least once during this procedure.

A

EC

Is the inspection result normal?

C

- YES >> INSPECTION END
- NO >> GO TO 6.

6. REPLACE HEATED OXYGEN SENSOR 2

D

Replace heated oxygen sensor 2.

CAUTION:

- Discard any sensor which has been dropped from a height of more than 0.5 m (19.7 in) onto a hard surface such as a concrete floor; use a new one.
- Before installing new sensor, clean exhaust system threads using Oxygen Sensor Thread Cleaner [commercial service tool (J-43897-18 or J43897-12)] and approved Anti-seize Lubricant (commercial service tool).

E

F

>> INSPECTION END

G

H

I

J

K

L

M

N

O

P

P0139 HO2S2

Description

INFOID:000000004833300

The heated oxygen sensor 2, after three way catalyst (manifold), monitors the oxygen level in the exhaust gas on each bank. Even if switching characteristics of the air fuel ratio (A/F) sensor 1 are shifted, the air-fuel ratio is controlled to stoichiometric, by the signal from the heated oxygen sensor 2. This sensor is made of ceramic zirconia. The zirconia generates voltage from approximately 1 V in richer conditions to 0 V in leaner conditions. Under normal conditions the heated oxygen sensor 2 is not used for engine control operation.

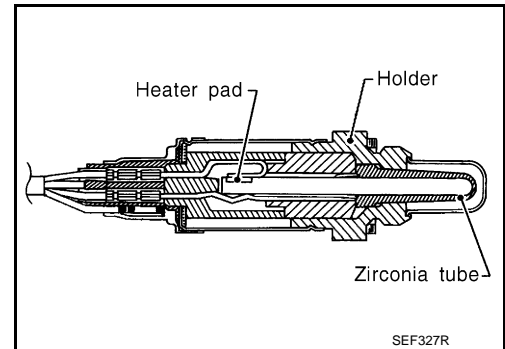

DTC Logic

INFOID:000000004833301

DTC DETECTION LOGIC

The heated oxygen sensor 2 has a much longer switching time between rich and lean than the air fuel ratio (A/F) sensor 1. The oxygen storage capacity of the three way catalyst (manifold) causes the longer switching time. To judge the malfunctions of heated oxygen sensor 2, ECM monitors whether the switching response of the sensor's voltage is faster than specified during the various driving condition such as fuel-cut.

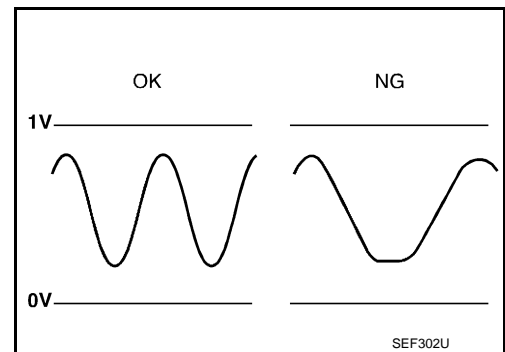

DTC No.	Trouble diagnosis name	DTC detecting condition	Possible cause
P0139	Heated oxygen sensor 2 circuit slow response	It takes more time for the sensor to respond between rich and lean than the specified time.	<ul style="list-style-type: none"> • Harness or connectors (The sensor circuit is open or shorted) • Heated oxygen sensor 2 • Fuel pressure • Fuel injector • Intake air leaks

DTC CONFIRMATION PROCEDURE

1.INSPECTION START

Do you have CONSULT-III?

Do you have CONSULT-III?

YES >> GO TO 2.

NO >> GO TO 5.

2.PRECONDITIONING

If DTC Confirmation Procedure has been previously conducted, always turn ignition switch OFF and wait at least 10 seconds before conducting the next test.

>> GO TO 3.

3.PERFORM DTC CONFIRMATION PROCEDURE

With CONSULT-III

1. Turn ignition switch ON and select "DATA MONITOR" mode with CONSULT-III.
2. Start engine and warm it up to normal operating temperature.

< DTC/CIRCUIT DIAGNOSIS >

3. Start engine and keep the engine speed between 3,500 and 4,000 rpm for at least 1 minute under no load.
4. Let engine idle for 1 minute.
5. Open engine hood.
6. Select "HO2S2 (B1) P0139" of "HO2S2" in "DTC WORK SUPPORT" mode with CONSULT-III.
7. Follow the instruction of CONSULT-III.

NOTE:

It will take at most 10 minutes until "COMPLETED" is displayed.

8. Touch "SELF-DIAG RESULT".

Which is displayed on CONSULT-III?

- OK >> INSPECTION END
- NG >> GO TO 4.
- CAN NOT BE DIAGNOSED>>GO TO 4.

4.PERFORM THE RESULT OF DTC CONFIRMATION PROCEDURE

1. Turn ignition switch OFF and leave the vehicle in a cool place (soak the vehicle).
2. Perform DTC CONFIRMATION PROCEDURE again.

>> GO TO 3.

5.PERFORM COMPONENT FUNCTION CHECK

Perform component function check. Refer to [EC-195, "Component Function Check"](#).

NOTE:

Use component function check to check the overall function of the heated oxygen sensor 2 circuit. During this check, a 1st trip DTC might not be confirmed.

Is the inspection result normal?

- YES >> INSPECTION END
- NO >> Go to [EC-196, "Diagnosis Procedure"](#).

Component Function Check

INFOID:000000004833302

1.PERFORM COMPONENT FUNCTION CHECK-I

⊗ Without CONSULT-III

1. Start engine and warm it up to normal operating temperature.
2. Turn ignition switch OFF and wait at least 10 seconds.
3. Start engine and keep the engine speed between 3,500 and 4,000 rpm for at least 1 minute under no load.
4. Let engine idle for 1 minute.
5. Check the voltage between ECM harness connector and ground under the following condition.

ECM		Ground	Condition	Voltage
Connector	Terminal			
F8	50 (HO2S2 signal)	Ground	Reving up to 4,000 rpm under no load at least 10 times	The voltage should be above 0.8 V at least once during this procedure.

Is the inspection result normal?

- YES >> INSPECTION END
- NO >> GO TO 2.

2.PERFORM COMPONENT FUNCTION CHECK-II

Check the voltage between ECM harness connector and ground under the following condition.

ECM		Ground	Condition	Voltage
Connector	Terminal			
F8	50 (HO2S2 signal)	Ground	Keeping engine speed at idle for 10 minutes	The voltage should be above 0.8 V at least once during this procedure.

Is the inspection result normal?

- YES >> INSPECTION END
- NO >> GO TO 3.

< DTC/CIRCUIT DIAGNOSIS >

3.PERFORM COMPONENT FUNCTION CHECK-III

Check the voltage between ECM harness connector and ground under the following condition.

ECM		Ground	Condition	Voltage
Connector	Terminal			
F8	50 (HO2S2 signal)	Ground	Coasting from 80 km/h (50 MPH) in D position (CVT), 4th gear position (M/T)	The voltage should be above 0.8 V at least once during this procedure.

Is the inspection result normal?

- YES >> INSPECTION END
- NO >> Go to [EC-196, "Diagnosis Procedure"](#).

Diagnosis Procedure

INFOID:000000004833304

1.CHECK GROUND CONNECTION

1. Turn ignition switch OFF.
2. Check ground connection E38. Refer to [GI-37, "Circuit Inspection"](#).

Is the inspection result normal?

- YES >> GO TO 2.
- NO >> Repair or replace ground connection.

2.CLEAR THE MIXTURE RATIO SELF-LEARNING VALUE

1. Clear the mixture ratio self-learning value. Refer to [EC-19, "MIXTURE RATIO SELF-LEARNING VALUE CLEAR : Special Repair Requirement"](#).
2. Run engine for at least 10 minutes at idle speed.

Is the 1st trip DTC P0171 or P0172 detected? Is it difficult to start engine?

- YES >> Perform trouble diagnosis for DTC P0171 or P0172. Refer to [EC-200, "DTC Logic"](#) or [EC-204, "DTC Logic"](#).
- NO >> GO TO 3.

3.CHECK HO2S2 GROUND CIRCUIT FOR OPEN AND SHORT

1. Turn ignition switch OFF.
2. Disconnect heated oxygen sensor 2 harness connector.
3. Disconnect ECM harness connector.
4. Check the continuity between HO2S2 harness connector and ECM harness connector.

HO2S2		ECM		Continuity
Connector	Terminal	Connector	Terminal	
F30	1	F8	59	Existed

5. Also check harness for short to ground and short to power.

Is the inspection result normal?

- YES >> GO TO 4.
- NO >> Repair open circuit or short to ground or short to power in harness or connectors.

4.CHECK HO2S2 INPUT SIGNAL CIRCUIT FOR OPEN AND SHORT

1. Check the continuity between HO2S2 harness connector and ECM harness connector.

HO2S2		ECM		Continuity
Connector	Terminal	Connector	Terminal	
F30	4	F8	50	Existed

2. Check the continuity between HO2S2 harness connector and ground, or ECM harness connector and ground.

< DTC/CIRCUIT DIAGNOSIS >

HO2S2		Ground	Continuity
Connector	Terminal		
F30	4	Ground	Not existed

ECM		Ground	Continuity
Connector	Terminal		
F8	50	Ground	Not existed

3. Also check harness for short to power.

Is the inspection result normal?

YES >> GO TO 5.

NO >> Repair open circuit or short to ground or short to power in harness or connectors.

5.CHECK HEATED OXYGEN SENSOR 2

Refer to [EC-197, "Component Inspection"](#).

Is the inspection result normal?

YES >> GO TO 7.

NO >> GO TO 6.

6.REPLACE HEATED OXYGEN SENSOR 2

Replace heated oxygen sensor 2.

CAUTION:

- Discard any sensor which has been dropped from a height of more than 0.5 m (19.7 in) onto a hard surface such as a concrete floor; use a new one.
- Before installing new sensor, clean exhaust system threads using Oxygen Sensor Thread Cleaner [commercial service tool (J-43897-18 or J43897-12)] and approved Anti-seize Lubricant (commercial service tool).

>> INSPECTION END

7.CHECK INTERMITTENT INCIDENT

Refer to [GI-34, "Intermittent Incident"](#).

>> INSPECTION END

Component Inspection

INFOID:000000004833305

1.INSPECTION START

Do you have CONSULT-III?

Do you have CONSULT-III?

YES >> GO TO 2.

NO >> GO TO 3.

2.CHECK HEATED OXYGEN SENSOR 2

Ⓜ With CONSULT-III

1. Turn ignition switch ON and select "DATA MONITOR" mode with CONSULT-III.
2. Start engine and warm it up to normal operating temperature.
3. Turn ignition switch OFF and wait at least 10 seconds.
4. Start engine and keep the engine speed between 3,500 and 4,000 rpm for at least 1 minute under no load.
5. Let engine idle for 1 minute.
6. Select "FUEL INJECTION" in "ACTIVE TEST" mode, and select "HO2S2 (B1)" as the monitor item with CONSULT-III.

< DTC/CIRCUIT DIAGNOSIS >

7. Check "HO2S2 (B1)" at idle speed when adjusting "FUEL INJECTION" to $\pm 25\%$.

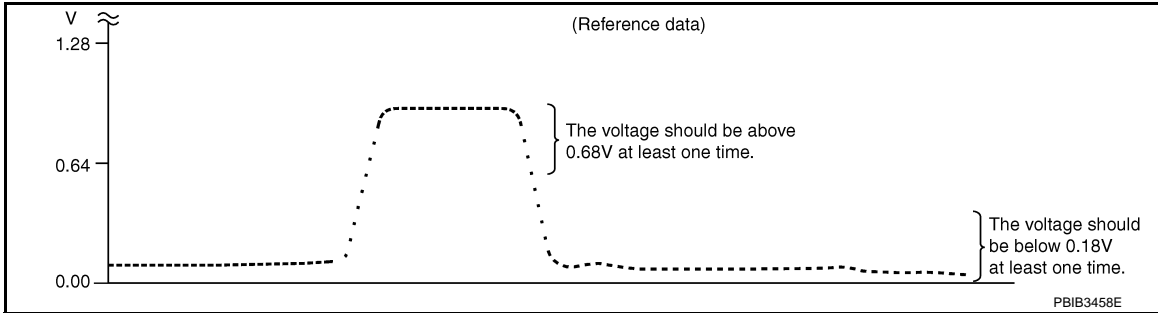

"HO2S2 (B1)" should be above 0.68 V at least once when the "FUEL INJECTION" is + 25%.
 "HO2S2 (B1)" should be below 0.18 V at least once when the "FUEL INJECTION" is - 25%.

Is the inspection result normal?

- YES >> INSPECTION END
- NO >> GO TO 6.

3.CHECK HEATED OXYGEN SENSOR 2-I

⊗ Without CONSULT-III

1. Start engine and warm it up to normal operating temperature.
2. Turn ignition switch OFF and wait at least 10 seconds.
3. Start engine and keep the engine speed between 3,500 and 4,000 rpm for at least 1 minute under no load.
4. Let engine idle for 1 minute.
5. Check the voltage between ECM harness connector and ground under the following condition.

ECM		Ground	Condition	Voltage
Connector	Terminal			
F8	50 (HO2S2 signal)	Ground	Revvig up to 4,000 rpm under no load at least 10 times	The voltage should be above 0.68 V at least once during this procedure. The voltage should be below 0.18 V at least once during this procedure.

Is the inspection result normal?

- YES >> INSPECTION END
- NO >> GO TO 4.

4.CHECK HEATED OXYGEN SENSOR 2-II

Check the voltage between ECM harness connector and ground under the following condition.

ECM		Ground	Condition	Voltage
Connector	Terminal			
F8	50 (HO2S2 signal)	Ground	Keeping engine speed at idle for 10 minutes	The voltage should be above 0.68 V at least once during this procedure. The voltage should be below 0.18 V at least once during this procedure.

Is the inspection result normal?

- YES >> INSPECTION END
- NO >> GO TO 5.

5.CHECK HEATED OXYGEN SENSOR 2-III

Check the voltage between ECM harness connector and ground under the following condition.

ECM		Ground	Condition	Voltage
Connector	Terminal			
F8	50 (HO2S2 signal)	Ground	Coasting from 80 km/h (50 MPH) in D position (CVT), 4th gear position (M/T)	The voltage should be above 0.68 V at least once during this procedure. The voltage should be below 0.18 V at least once during this procedure.

A
EC

Is the inspection result normal?

C

- YES >> INSPECTION END
- NO >> GO TO 6.

6. REPLACE HEATED OXYGEN SENSOR 2

D

Replace heated oxygen sensor 2.

CAUTION:

- Discard any sensor which has been dropped from a height of more than 0.5 m (19.7 in) onto a hard surface such as a concrete floor; use a new one.
- Before installing new sensor, clean exhaust system threads using Oxygen Sensor Thread Cleaner [commercial service tool (J-43897-18 or J43897-12)] and approved Anti-seize Lubricant (commercial service tool).

E

F

>> INSPECTION END

G

H

I

J

K

L

M

N

O

P

P0171 FUEL INJECTION SYSTEM FUNCTION

< DTC/CIRCUIT DIAGNOSIS >

[MR18DE]

P0171 FUEL INJECTION SYSTEM FUNCTION

DTC Logic

INFOID:000000004833306

DTC DETECTION LOGIC

With the Air/Fuel Mixture Ratio Self-Learning Control, the actual mixture ratio can be brought closely to the theoretical mixture ratio based on the mixture ratio feedback signal from the A/F sensors 1. The ECM calculates the necessary compensation to correct the offset between the actual and the theoretical ratios.

In case the amount of the compensation value is extremely large (The actual mixture ratio is too lean.), the ECM judges the condition as the fuel injection system malfunction and lights up the MIL (2 trip detection logic).

Sensor	Input signal to ECM	ECM function	Actuator
A/F sensor 1	Density of oxygen in exhaust gas (Mixture ratio feedback signal)	Fuel injection control	Fuel injector

DTC No.	Trouble diagnosis name	DTC detecting condition	Possible cause
P0171	Fuel injection system too lean	<ul style="list-style-type: none">Fuel injection system does not operate properly.The amount of mixture ratio compensation is too large. (The mixture ratio is too lean.)	<ul style="list-style-type: none">Intake air leaksA/F sensor 1Fuel injectorExhaust gas leaksIncorrect fuel pressureLack of fuelMass air flow sensorIncorrect PCV hose connection

DTC CONFIRMATION PROCEDURE

1. PRECONDITIONING

If DTC Confirmation Procedure has been previously conducted, always turn ignition switch OFF and wait at least 10 seconds before conducting the next test.

>> GO TO 2.

2. PERFORM DTC CONFIRMATION PROCEDURE-I

1. Clear the mixture ratio self-learning value. Refer to [EC-19, "MIXTURE RATIO SELF-LEARNING VALUE CLEAR : Special Repair Requirement"](#).
2. Start engine.

Is it difficult to start engine?

- YES >> GO TO 3.
NO >> GO TO 4.

3. RESTART ENGINE

If it is difficult to start engine, the fuel injection system has a malfunction, too.
Crank engine while depressing accelerator pedal.

NOTE:

When depressing accelerator pedal three-fourths (3/4) or more, the control system does not start the engine. Do not depress accelerator pedal too much.

Does engine start?

- YES >> Go to [EC-201, "Diagnosis Procedure"](#).
NO >> Check exhaust and intake air leak visually.

4. PERFORM DTC CONFIRMATION PROCEDURE-II

1. Start engine and let it idle for at least 5 minutes.
2. Check 1st trip DTC.

Is 1st trip DTC detected?

- YES >> Go to [EC-201, "Diagnosis Procedure"](#).
NO >> GO TO 5.

P0171 FUEL INJECTION SYSTEM FUNCTION

< DTC/CIRCUIT DIAGNOSIS >

[MR18DE]

5. PERFORM DTC CONFIRMATION PROCEDURE-III

1. Turn ignition switch OFF and wait at least 10 seconds.
2. Start engine.
3. Maintain the following conditions for at least 10 consecutive minutes.
Hold the accelerator pedal as steady as possible.

VHCL SPEED SE	50 - 120 km/h (31 - 75 MPH)
---------------	-----------------------------

CAUTION:

Always drive vehicle at a safe speed.

4. Check 1st trip DTC.

Is 1st trip DTC detected?

- YES >> Go to [EC-201, "Diagnosis Procedure"](#).
NO >> INSPECTION END

Diagnosis Procedure

INFOID:000000004833308

1. CHECK EXHAUST GAS LEAK

1. Start engine and run it at idle.
2. Listen for an exhaust gas leak before three way catalyst (manifold).

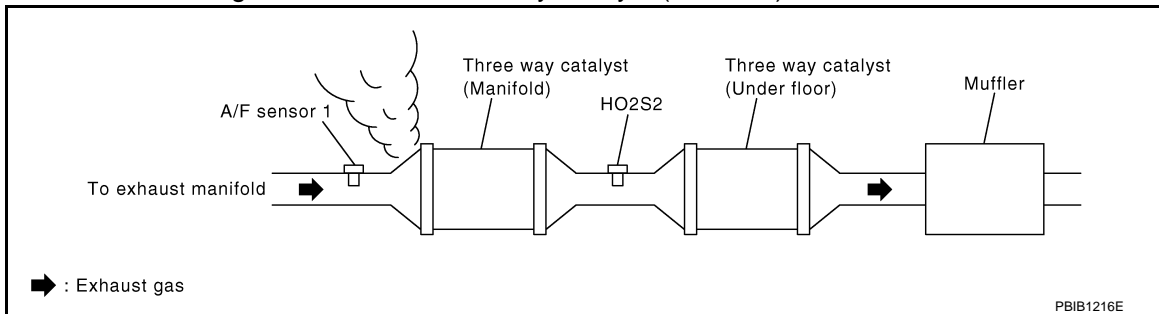

Is exhaust gas leak detected?

- YES >> Repair or replace.
NO >> GO TO 2.

2. CHECK FOR INTAKE AIR LEAK

1. Listen for an intake air leak after the mass air flow sensor.
2. Check PCV hose connection.

Intake air leak detected?

- YES >> Repair or replace.
NO >> GO TO 3.

3. CHECK A/F SENSOR 1 INPUT SIGNAL CIRCUIT

1. Turn ignition switch OFF.
2. Disconnect corresponding A/F sensor 1 harness connector.
3. Disconnect ECM harness connector.
4. Check the continuity between A/F sensor 1 harness connector and ECM harness connector.

A/F sensor 1		ECM		Continuity
Connector	Terminal	Connector	Terminal	
F50	1	F8	49	Existed
	2		53	

5. Check the continuity between A/F sensor 1 harness connector and ground, or ECM harness connector and ground.

P0171 FUEL INJECTION SYSTEM FUNCTION

[MR18DE]

< DTC/CIRCUIT DIAGNOSIS >

A/F sensor 1		Ground	Continuity
Connector	Terminal		
F50	1	Ground	Not existed
	2		

ECM		Ground	Continuity
Connector	Terminal		
F8	49	Ground	Not existed
	53		

6. Also check harness for short to power.

Is the inspection result normal?

YES >> GO TO 4.

NO >> Repair open circuit or short to ground or short to power in harness or connectors.

4. CHECK FUEL PRESSURE

1. Check fuel pressure. Refer to [EC-471, "Inspection"](#).

Is the inspection result normal?

YES >> GO TO 6.

NO >> GO TO 5.

5. DETECT MALFUNCTIONING PART

Check fuel hoses and fuel tubes for clogging.

Is the inspection result normal?

YES >> Replace "fuel filter and fuel pump assembly".

NO >> Repair or replace

6. CHECK MASS AIR FLOW SENSOR

 **With CONSULT-III**

1. Install all removed parts.
2. Check "MASS AIR FLOW" in "DATA MONITOR" mode with CONSULT-III.
3. For specification, refer to [EC-477, "Mass Air Flow Sensor"](#).

 **With GST**

1. Install all removed parts.
2. Check mass air flow sensor signal in Service \$01 with GST.
3. For specification, refer to [EC-477, "Mass Air Flow Sensor"](#).

Is the measurement value within the specification?

YES >> GO TO 7.

NO >> Check connectors for rusted terminals or loose connections in the mass air flow sensor circuit or grounds. Refer to [EC-136, "DTC Logic"](#).

7. CHECK FUNCTION OF FUEL INJECTOR

 **With CONSULT-III**

1. Start engine.
2. Perform "POWER BALANCE" in "ACTIVE TEST" mode with CONSULT-III.
3. Make sure that each circuit produces a momentary engine speed drop.

 **Without CONSULT-III**

1. Let engine idle.

P0171 FUEL INJECTION SYSTEM FUNCTION

[MR18DE]

< DTC/CIRCUIT DIAGNOSIS >

2. Listen to each fuel injector operating sound.

Clicking noise should be heard.

Is the inspection result normal?

YES >> GO TO 8.

NO >> Perform trouble diagnosis for FUEL INJECTOR, refer to [EC-395. "Component Function Check"](#).

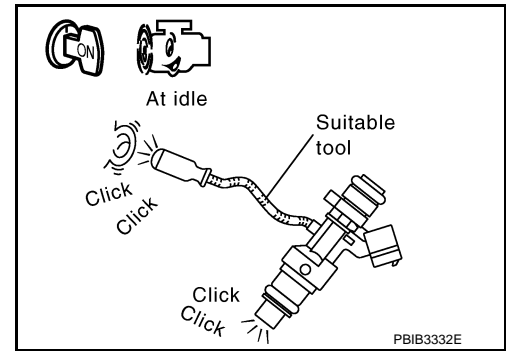

8. CHECK FUEL INJECTOR

1. Turn ignition switch OFF.
2. Confirm that the engine is cooled down and there are no fire hazards near the vehicle.
3. Disconnect all fuel injector harness connectors.
4. Remove fuel tube assembly. Refer to [EM-35. "Removal and Installation"](#).
Keep fuel hose and all fuel injectors connected to fuel tube.
5. Disconnect all ignition coil harness connectors.
6. Prepare pans or saucers under each fuel injector.
7. Crank engine for about 3 seconds.

Fuel should be sprayed evenly for each fuel injector.

Is the inspection result normal?

YES >> GO TO 9.

NO >> Replace fuel injectors from which fuel does not spray out. Always replace O-ring with new ones.

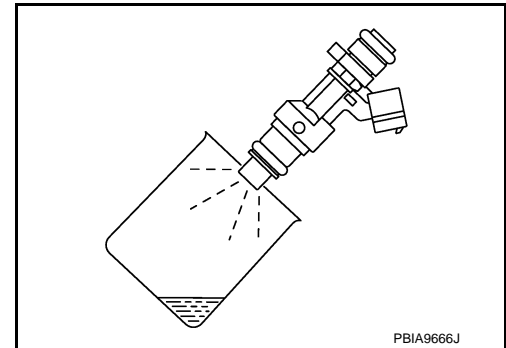

9. CHECK INTERMITTENT INCIDENT

Refer to [GI-34. "Intermittent Incident"](#).

>> INSPECTION END

P0172 FUEL INJECTION SYSTEM FUNCTION

< DTC/CIRCUIT DIAGNOSIS >

[MR18DE]

P0172 FUEL INJECTION SYSTEM FUNCTION

DTC Logic

INFOID:000000004833309

DTC DETECTION LOGIC

With the Air/Fuel Mixture Ratio Self-Learning Control, the actual mixture ratio can be brought closely to the theoretical mixture ratio based on the mixture ratio feedback signal from the A/F sensors 1. The ECM calculates the necessary compensation to correct the offset between the actual and the theoretical ratios.

In case the amount of the compensation value is extremely large (The actual mixture ratio is too rich.), the ECM judges the condition as the fuel injection system malfunction and lights up the MIL (2 trip detection logic).

Sensor	Input signal to ECM	ECM function	Actuator
A/F sensor 1	Density of oxygen in exhaust gas (Mixture ratio feedback signal)	Fuel injection control	Fuel injector

DTC No.	Trouble diagnosis name	DTC detecting condition	Possible cause
P0172	Fuel injection system too rich	<ul style="list-style-type: none">Fuel injection system does not operate properly.The amount of mixture ratio compensation is too large. (The mixture ratio is too rich.)	<ul style="list-style-type: none">A/F sensor 1Fuel injectorExhaust gas leaksIncorrect fuel pressureMass air flow sensor

DTC CONFIRMATION PROCEDURE

1. PRECONDITIONING

If DTC Confirmation Procedure has been previously conducted, always turn ignition switch OFF and wait at least 10 seconds before conducting the next test.

>> GO TO 2.

2. PERFORM DTC CONFIRMATION PROCEDURE-I

1. Clear the mixture ratio self-learning value. Refer to [EC-19, "MIXTURE RATIO SELF-LEARNING VALUE CLEAR : Special Repair Requirement"](#).
2. Start engine.

Is it difficult to start engine?

- YES >> GO TO 3.
NO >> GO TO 4.

3. RESTART ENGINE

If it is difficult to start engine, the fuel injection system has a malfunction, too.

Crank engine while depressing accelerator pedal.

NOTE:

When depressing accelerator pedal three-fourths (3/4) or more, the control system does not start the engine. Do not depress accelerator pedal too much.

Does engine start?

- YES >> Go to [EC-205, "Diagnosis Procedure"](#).
NO >> Check exhaust and intake air leak visually.

4. PERFORM DTC CONFIRMATION PROCEDURE-II

1. Start engine and let it idle for at least 5 minutes.
2. Check 1st trip DTC.

Is 1st trip DTC detected?

- YES >> Go to [EC-205, "Diagnosis Procedure"](#).
NO >> GO TO 5.

5. PERFORM DTC CONFIRMATION PROCEDURE-III

1. Turn ignition switch OFF and wait at least 10 seconds.
2. Start engine.

P0172 FUEL INJECTION SYSTEM FUNCTION

[MR18DE]

< DTC/CIRCUIT DIAGNOSIS >

- Maintain the following conditions for at least 10 consecutive minutes.
Hold the accelerator pedal as steady as possible.

VHCL SPEED SE	50 - 120 km/h (31 - 75 MPH)
---------------	-----------------------------

CAUTION:

Always drive vehicle at a safe speed.

- Check 1st trip DTC.

Is 1st trip DTC detected?

- YES >> Go to [EC-205. "Diagnosis Procedure"](#).
NO >> INSPECTION END

Diagnosis Procedure

INFOID:000000004833311

1.CHECK EXHAUST GAS LEAK

- Start engine and run it at idle.
- Listen for an exhaust gas leak before three way catalyst (manifold).

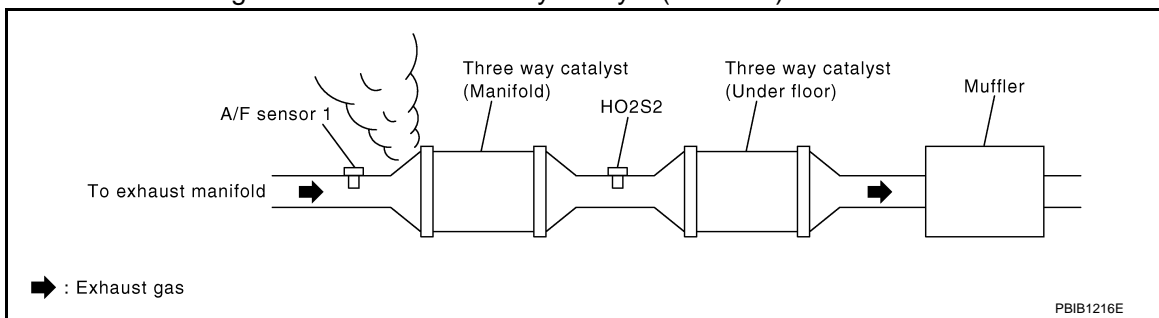

Is exhaust gas leak detected?

- YES >> Repair or replace.
NO >> GO TO 2.

2.CHECK FOR INTAKE AIR LEAK

Listen for an intake air leak after the mass air flow sensor.

Is intake air leak detected?

- YES >> Repair or replace.
NO >> GO TO 3.

3.CHECK A/F SENSOR 1 INPUT SIGNAL CIRCUIT

- Turn ignition switch OFF.
- Disconnect corresponding A/F sensor 1 harness connector.
- Disconnect ECM harness connector.
- Check the continuity between A/F sensor 1 harness connector and ECM harness connector.

A/F sensor 1		ECM		Continuity
Connector	Terminal	Connector	Terminal	
F50	1	F8	49	Existed
	2		53	

- Check the continuity between A/F sensor 1 harness connector and ground, or ECM harness connector and ground.

A/F sensor 1		Ground	Continuity
Connector	Terminal		
F50	1	Ground	Not existed
	2		

P0172 FUEL INJECTION SYSTEM FUNCTION

[MR18DE]

< DTC/CIRCUIT DIAGNOSIS >

ECM		Ground	Continuity
Connector	Terminal		
F8	49	Ground	Not existed
	53		

6. Also check harness for short to power.

Is the inspection result normal?

YES >> GO TO 4.

NO >> Repair open circuit or short to ground or short to power in harness or connectors.

4. CHECK FUEL PRESSURE

1. Check fuel pressure. Refer to [EC-471, "Inspection"](#).

Is the inspection result normal?

YES >> GO TO 6.

NO >> GO TO 5.

5. DETECT MALFUNCTIONING PART

Check fuel hoses and fuel tubes for clogging.

Is the inspection result normal?

YES >> Replace "fuel filter and fuel pump assembly".

NO >> Repair or replace

6. CHECK MASS AIR FLOW SENSOR

 **With CONSULT-III**

1. Install all removed parts.

2. Check "MASS AIR FLOW" in "DATA MONITOR" mode with CONSULT-III.

3. For specification, refer to [EC-477, "Mass Air Flow Sensor"](#).

 **With GST**

1. Install all removed parts.

2. Check mass air flow sensor signal in "Service \$01" with GST.

3. For specification, refer to [EC-477, "Mass Air Flow Sensor"](#).

Is the measurement value within the specification?

YES >> GO TO 7.

NO >> Check connectors for rusted terminals or loose connections in the mass air flow sensor circuit or grounds. Refer to [EC-136, "DTC Logic"](#).

7. CHECK FUNCTION OF FUEL INJECTOR

 **With CONSULT-III**

1. Start engine.

2. Perform "POWER BALANCE" in "ACTIVE TEST" mode with CONSULT-III.

3. Make sure that each circuit produces a momentary engine speed drop.

 **Without CONSULT-III**

1. Let engine idle.

2. Listen to each fuel injector operating sound.

Clicking noise should be heard.

Is the inspection result normal?

YES >> GO TO 8.

NO >> Perform trouble diagnosis for FUEL INJECTOR, refer to [EC-395, "Component Function Check"](#).

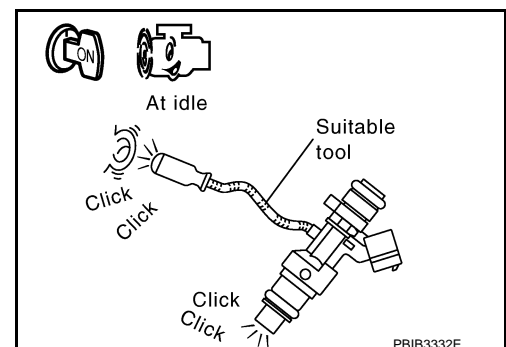

P0172 FUEL INJECTION SYSTEM FUNCTION

< DTC/CIRCUIT DIAGNOSIS >

[MR18DE]

8. CHECK FUEL INJECTOR

1. Remove fuel injector assembly. Refer to [EM-35. "Removal and Installation"](#).
Keep fuel hose and all fuel injectors connected to fuel tube.
2. Confirm that the engine is cooled down and there are no fire hazards near the vehicle.
3. Disconnect all fuel injector harness connectors.
4. Disconnect all ignition coil harness connectors.
5. Prepare pans or saucers under each fuel injectors.
6. Crank engine for about 3 seconds.
Make sure fuel does not drip from fuel injector.

Is the inspection result normal?

YES >> GO TO 9.

NO >> Replace the fuel injectors from which fuel is dripping. Always replace O-ring with new one.

9. CHECK INTERMITTENT INCIDENT

Refer to [GI-34. "Intermittent Incident"](#).

>> INSPECTION END

A

EC

C

D

E

F

G

H

I

J

K

L

M

N

O

P

P0181 FTT SENSOR

Description

INFOID:000000004833312

The fuel tank temperature sensor is used to detect the fuel temperature inside the fuel tank. The sensor modifies a voltage signal from the ECM. The modified signal returns to the ECM as the fuel temperature input. The sensor uses a thermistor which is sensitive to the change in temperature. The electrical resistance of the thermistor decreases as temperature increases.

<Reference data>

Fluid temperature [°C (°F)]	Voltage* [V]	Resistance [kΩ]
20 (68)	3.5	2.3 - 2.7
50 (122)	2.2	0.79 - 0.90

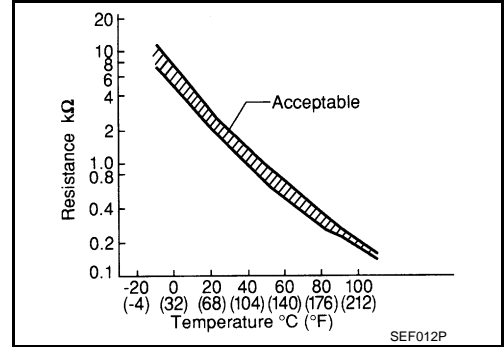

*: These data are reference values and are measured between ECM terminal 43 (Fuel tank temperature sensor) and ground.

DTC Logic

INFOID:000000004833313

DTC DETECTION LOGIC

DTC No.	Trouble diagnosis name	DTC detecting condition	Possible cause
P0181	Fuel tank temperature sensor circuit range/performance	Rationally incorrect voltage from the sensor is sent to ECM, compared with the voltage signals from engine coolant temperature sensor and intake air temperature sensor.	<ul style="list-style-type: none"> • Harness or connectors (The sensor circuit is open or shorted) • Fuel tank temperature sensor

DTC CONFIRMATION PROCEDURE

1. PRECONDITIONING

If DTC Confirmation Procedure has been previously conducted, always turn ignition switch OFF and wait at least 10 seconds before conducting the next test.

>> GO TO 2.

2. PERFORM DTC CONFIRMATION PROCEDURE-I

1. Turn ignition switch and wait at least 10 seconds.
2. Check 1st trip DTC.

Is 1st trip DTC detected?

- YES >> Go to [EC-209, "Diagnosis Procedure"](#).
- NO >> GO TO 3.

3. CHECK ENGINE COOLANT TEMPERATURE

With CONSULT-III

1. Select "COOLAN TEMP/S" in "DATA MONITOR" mode with CONSULT-III.
2. Check "COOLAN TEMP/S" indication.

With GST

Follow the procedure "With CONSULT-III" above.

Is "COOLAN TEMP/S" indication less than 60°C (140°F)?

- YES >> INSPECTION END
- NO >> GO TO 4.

4. PERFORM DTC CONFIRMATION PROCEDURE-II

With CONSULT-III

1. Cool engine down until "COOLAN TEMP/S" indication is less than 60°C (140°F).
2. Wait at least 10 seconds.

< DTC/CIRCUIT DIAGNOSIS >

3. Check 1st trip DTC.

 **With GST**

Follow the procedure "With CONSULT-III" above.

Is 1st trip DTC detected?

- YES >> Go to [EC-209, "Diagnosis Procedure"](#).
- NO >> INSPECTION END

Diagnosis Procedure

INFOID:000000004833315

1.CHECK GROUND CONNECTION

1. Turn ignition switch OFF.
2. Check ground connection E38. Refer to [GI-34, "Intermittent Incident"](#).

Is the inspection result normal?

- YES >> GO TO 2.
- NO >> Repair or replace ground connection.

2.CHECK FUEL TANK TEMPERATURE SENSOR POWER SUPPLY CIRCUIT

1. Turn ignition switch OFF.
2. Disconnect "fuel level sensor unit and fuel pump" harness connector.
3. Turn ignition switch ON.
4. Check the voltage between "fuel level sensor unit and fuel pump" harness connector and ground.

Fuel level sensor unit and fuel pump		Ground	Voltage
Connector	Terminal		
B40	4	Ground	Approx. 5 V

Is the inspection result normal?

- YES >> GO TO 4.
- NO >> GO TO 3.

3.DETECT MALFUNCTIONING PART

Check the following.

- Harness connectors B4, M79
- Harness connectors M77, E105
- Harness connectors E8, F1
- Harness for open or short between ECM and "fuel level sensor unit and fuel pump"

>> Repair open circuit or short to ground or short to power in harness or connector.

4.CHECK FUEL TANK TEMPERATURE SENSOR GROUND CIRCUIT FOR OPEN AND SHORT

1. Turn ignition switch OFF.
2. Disconnect combination meter harness connector.
3. Check the continuity between "fuel level sensor unit and fuel pump" harness connector and ECM harness connector.

Fuel level sensor unit and fuel pump		Combination meter		Continuity
Connector	Terminal	Connector	Terminal	
B40	5	M34	24	Existed

4. Also check harness for short to ground and short to power.

Is the inspection result normal?

- YES >> GO TO 6.
- NO >> GO TO 5.

5.DETECT MALFUNCTIONING PART

Check the following.

- Harness connectors M79, B4

P0181 FTT SENSOR

[MR18DE]

< DTC/CIRCUIT DIAGNOSIS >

- Harness for open or short between “fuel level sensor unit and fuel pump” and combination meter

>> Repair open circuit or short to ground or short to power in harness or connector.

6.CHECK FUEL TANK TEMPERATURE SENSOR

Refer to [EC-210, "Component Inspection"](#).

Is the inspection result normal?

YES >> GO TO 7.

NO >> Replace “fuel level sensor unit and fuel pump”.

7.CHECK INTERMITTENT INCIDENT

Refer to [GI-34, "Intermittent Incident"](#).

>> INSPECTION END

Component Inspection

INFOID:000000004833316

1.CHECK FUEL TANK TEMPERATURE SENSOR

1. Turn ignition switch OFF.
2. Disconnect “fuel level sensor unit and fuel pump” harness connector.
3. Remove fuel level sensor unit.
4. Check resistance between “fuel level sensor unit and fuel pump” terminals by heating with hot water as shown in the figure.

Terminals	Condition	Resistance	
4 and 5	Temperature [°C (°F)]	20 (68)	2.3 - 2.7 kΩ
		50 (122)	0.79 - 0.90 kΩ

Is the inspection result normal?

YES >> INSPECTION END

NO >> Replace “fuel level sensor unit and fuel pump”.

P0182, P0183 FTT SENSOR

Description

INFOID:000000004833317

The fuel tank temperature sensor is used to detect the fuel temperature inside the fuel tank. The sensor modifies a voltage signal from the ECM. The modified signal returns to the ECM as the fuel temperature input. The sensor uses a thermistor which is sensitive to the change in temperature. The electrical resistance of the thermistor decreases as temperature increases.

<Reference data>

Fluid temperature [°C (°F)]	Voltage* [V]	Resistance [kΩ]
20 (68)	3.5	2.3 - 2.7
50 (122)	2.2	0.79 - 0.90

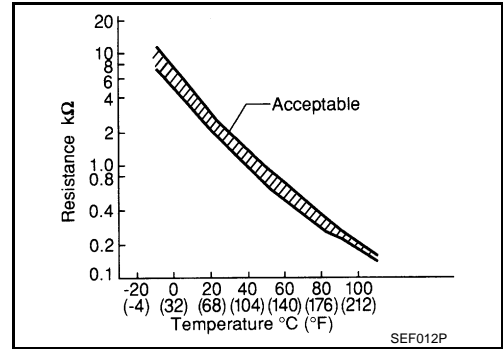

*: These data are reference values and are measured between ECM terminal 43 (Fuel tank temperature sensor) and ground.

DTC Logic

INFOID:000000004833318

DTC DETECTION LOGIC

DTC No.	Trouble diagnosis name	DTC detecting condition	Possible cause
P0182	Fuel tank temperature sensor circuit low input	An excessively low voltage from the sensor is sent to ECM.	<ul style="list-style-type: none"> • Harness or connectors (The sensor circuit is open or shorted.) • Fuel tank temperature sensor
P0183	Fuel tank temperature sensor circuit high input	An excessively high voltage from the sensor is sent to ECM.	

DTC CONFIRMATION PROCEDURE

1. PRECONDITIONING

If DTC Confirmation Procedure has been previously conducted, always turn ignition switch OFF and wait at least 10 seconds before conducting the next test.

>> GO TO 2.

2. PERFORM DTC CONFIRMATION PROCEDURE

1. Turn ignition switch ON and wait at least 5 seconds.
2. Check 1st trip DTC.

Is 1st trip DTC detected?

- YES >> Go to [EC-211, "Diagnosis Procedure"](#).
- NO >> INSPECTION END

Diagnosis Procedure

INFOID:000000004833320

1. CHECK GROUND CONNECTION

1. Turn ignition switch OFF.
2. Check ground connection E38. Refer to [GI-34, "Intermittent Incident"](#).

Is the inspection result normal?

- YES >> GO TO 2.
- NO >> Repair or replace ground connection.

2. CHECK FUEL TANK TEMPERATURE SENSOR POWER SUPPLY CIRCUIT

1. Turn ignition switch OFF.
2. Disconnect "fuel level sensor unit and fuel pump" harness connector.
3. Turn ignition switch ON.
4. Check the voltage between "fuel level sensor unit and fuel pump" harness connector and ground.

P0182, P0183 FTT SENSOR

[MR18DE]

< DTC/CIRCUIT DIAGNOSIS >

Fuel level sensor unit and fuel pump		Ground	Voltage
Connector	Terminal		
B40	4	Ground	Approx. 5 V

Is the inspection result normal?

- YES >> GO TO 4.
- NO >> GO TO 3.

3. DETECT MALFUNCTIONING PART

Check the following.

- Harness connectors B4, M79
- Harness connectors M77, E105
- Harness connectors E8, F1
- Harness for open or short between ECM and “fuel level sensor unit and fuel pump”

>> Repair open circuit or short to ground or short to power in harness or connector.

4. CHECK FUEL TANK TEMPERATURE SENSOR GROUND CIRCUIT FOR OPEN AND SHORT

1. Turn ignition switch OFF.
2. Disconnect combination meter harness connector.
3. Check the continuity between “fuel level sensor unit and fuel pump” harness connector and ECM harness connector.

Fuel level sensor unit and fuel pump		Combination meter		Continuity
Connector	Terminal	Connector	Terminal	
B40	5	M34	24	Existed

4. Also check harness for short to ground and short to power.

Is the inspection result normal?

- YES >> GO TO 6.
- NO >> GO TO 5.

5. DETECT MALFUNCTIONING PART

Check the following.

- Harness connectors M79, B4
- Harness for open or short between “fuel level sensor unit and fuel pump” and combination meter

>> Repair open circuit or short to ground or short to power in harness or connector.

6. CHECK FUEL TANK TEMPERATURE SENSOR

Refer to [EC-212. "Component Inspection"](#).

Is the inspection result normal?

- YES >> GO TO 7.
- NO >> Replace “fuel level sensor unit and fuel pump”.

7. CHECK INTERMITTENT INCIDENT

Refer to [GI-34. "Intermittent Incident"](#).

>> INSPECTION END

Component Inspection

INFOID:000000004833321

1. CHECK FUEL TANK TEMPERATURE SENSOR

1. Turn ignition switch OFF.
2. Disconnect “fuel level sensor unit and fuel pump” harness connector.
3. Remove fuel level sensor unit.

P0182, P0183 FTT SENSOR

[MR18DE]

< DTC/CIRCUIT DIAGNOSIS >

4. Check resistance between “fuel level sensor unit and fuel pump” terminals by heating with hot water as shown in the figure.

Terminals	Condition	Resistance	
4 and 5	Temperature [°C (°F)]	20 (68)	2.3 - 2.7 kΩ
		50 (122)	0.79 - 0.90 kΩ

Is the inspection result normal?

YES >> INSPECTION END

NO >> Replace “fuel level sensor unit and fuel pump”.

A

EC

C

D

E

F

G

H

I

J

K

L

M

N

O

P

P0222, P0223 TP SENSOR

Description

INFOID:000000004833322

Electric throttle control actuator consists of throttle control motor, throttle position sensor, etc. The throttle position sensor responds to the throttle valve movement.

The throttle position sensor has two sensors. These sensors are a kind of potentiometer which transform the throttle valve position into output voltage, and emit the voltage signals to the ECM. The ECM judges the current opening angle of the throttle valve from these signals and controls the throttle valve opening angle in response to driving conditions via the throttle control motor.

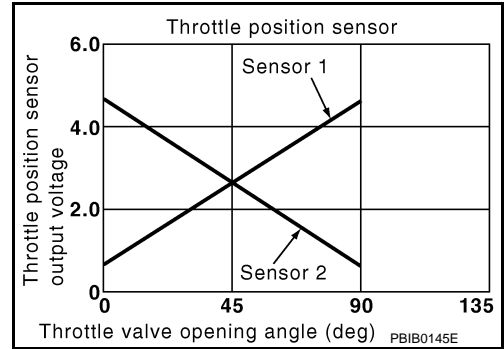

DTC Logic

INFOID:000000004833323

DTC DETECTION LOGIC

NOTE:

If DTC P0222 or P0223 is displayed with DTC P0643 ,first perform the trouble diagnosis for DTC P0643. Refer to [EC-229, "DTC Logic"](#).

DTC No.	Trouble diagnosis name	DTC detecting condition	Possible cause
P0222	Throttle position sensor 1 circuit low input	An excessively low voltage from the TP sensor 1 is sent to ECM.	<ul style="list-style-type: none"> Harness or connectors (TP sensor 1 circuit is open or shorted.)
P0223	Throttle position sensor 1 circuit high input	An excessively high voltage from the TP sensor 1 is sent to ECM.	<ul style="list-style-type: none"> Electric throttle control actuator (TP sensor 1)

DTC CONFIRMATION PROCEDURE

1.PRECONDITIONING

If DTC Confirmation Procedure has been previously conducted, always turn ignition switch OFF and wait at least 10 seconds before conducting the next test.

TESTING CONDITION:

Before performing the following procedure, confirm that battery voltage is more than 8 V at idle.

>> GO TO 2.

2.PERFORM DTC CONFIRMATION PROCEDURE

1. Start engine and let it idle for 1 second.
2. Check DTC.

Is DTC detected?

YES >> Go to [EC-214, "Diagnosis Procedure"](#).

NO >> INSPECTION END

Diagnosis Procedure

INFOID:000000004833325

1.CHECK GROUND CONNECTION

1. Turn ignition switch OFF.
2. Check ground connection E38. Refer to [GI-37, "Circuit Inspection"](#).

Is the inspection result normal?

YES >> GO TO 2.

NO >> Repair or replace ground connection.

2.CHECK THROTTLE POSITION SENSOR 1 POWER SUPPLY CIRCUIT

1. Disconnect electric throttle control actuator harness connector.
2. Turn ignition switch ON.

P0222, P0223 TP SENSOR

[MR18DE]

< DTC/CIRCUIT DIAGNOSIS >

3. Check the voltage between electric throttle control actuator harness connector and ground.

Electric throttle control actuator		Ground	Voltage
Connector	Terminal		
F29	2	Ground	Approx. 5 V

Is the inspection result normal?

YES >> GO TO 3.

NO >> Repair open circuit or short to ground or short to power in harness or connectors.

3.CHECK THROTTLE POSITION SENSOR 1 GROUND CIRCUIT FOR OPEN AND SHORT

1. Turn ignition switch OFF.
2. Disconnect ECM harness connector.
3. Check the continuity between electric throttle control actuator harness connector and ECM harness connector.

Electric throttle control actuator		ECM		Continuity
Connector	Terminal	Connector	Terminal	
F29	4	F8	36	Existed

4. Also check harness for short to ground and short to power.

Is the inspection result normal?

YES >> GO TO 4.

NO >> Repair open circuit or short to ground or short to power in harness or connectors.

4.CHECK THROTTLE POSITION SENSOR 1 INPUT SIGNAL CIRCUIT FOR OPEN AND SHORT

1. Check the continuity between electric throttle control actuator harness connector and ECM harness connector.

Electric throttle control actuator		ECM		Continuity
Connector	Terminal	Connector	Terminal	
F29	1	F8	33	Existed

2. Also check harness for short to ground and short to power.

Is the inspection result normal?

YES >> GO TO 5.

NO >> Repair open circuit or short to ground or short to power in harness or connectors.

5.CHECK THROTTLE POSITION SENSOR

Refer to [EC-216, "Component Inspection"](#).

Is the inspection result normal?

YES >> GO TO 7.

NO >> GO TO 6.

6.REPLACE ELECTRIC THROTTLE CONTROL ACTUATOR

1. Replace electric throttle control actuator.
2. Perform [EC-216, "Special Repair Requirement"](#).

>> INSPECTION END

7.CHECK INTERMITTENT INCIDENT

Refer to [GI-34, "Intermittent Incident"](#).

>> INSPECTION END

P0222, P0223 TP SENSOR

< DTC/CIRCUIT DIAGNOSIS >

[MR18DE]

INFOID:000000004833326

Component Inspection

1. CHECK THROTTLE POSITION SENSOR

1. Turn ignition switch OFF.
2. Reconnect all harness connectors disconnected.
3. Perform [EC-17. "THROTTLE VALVE CLOSED POSITION LEARNING : Special Repair Requirement"](#).
4. Turn ignition switch ON.
5. Set selector lever to D (CVT) or 1st (M/T) position.
6. Check the voltage between ECM harness connector and ground.

ECM		Ground	Condition	Voltage	
Connector	Terminal				
F8	33 (TP sensor 1 signal)	Ground	Accelerator pedal	Fully released	More than 0.36V
			Fully de- pressed	Less than 4.75V	
	34 (TP sensor 2 signal)		Fully released	Less than 4.75V	
			Fully de- pressed	More than 0.36V	

Is the inspection result normal?

- YES >> INSPECTION END
NO >> GO TO 2.

2. REPLACE ELECTRIC THROTTLE CONTROL ACTUATOR

1. Replace electric throttle control actuator.
2. Perform [EC-216. "Special Repair Requirement"](#).

>> INSPECTION END

Special Repair Requirement

INFOID:000000004833327

1. PERFORM THROTTLE VALVE CLOSED POSITION LEARNING

Refer to [EC-17. "THROTTLE VALVE CLOSED POSITION LEARNING : Special Repair Requirement"](#)

>> GO TO 2.

2. PERFORM IDLE AIR VOLUME LEARNING

Refer to [EC-17. "IDLE AIR VOLUME LEARNING : Special Repair Requirement"](#)

>> END

P0300, P0301, P0302, P0303, P0304 MISFIRE

DTC Logic

INFOID:000000004833328

DTC DETECTION LOGIC

When a misfire occurs, engine speed will fluctuate. If the engine speed fluctuates enough to cause the crankshaft position (CKP) sensor (POS) signal to vary, ECM can determine that a misfire is occurring.

Sensor	Input signal to ECM	ECM function
Crankshaft position sensor (POS)	Engine speed	On board diagnosis of misfire

The misfire detection logic consists of the following two conditions.

- One Trip Detection Logic (Three Way Catalyst Damage)**
 On the 1st trip, when a misfire condition occurs that can damage the three way catalyst (TWC) due to overheating, the MIL will blink.
 When a misfire condition occurs, the ECM monitors the CKP sensor signal every 200 engine revolutions for a change.
 When the misfire condition decreases to a level that will not damage the TWC, the MIL will turn off.
 If another misfire condition occurs that can damage the TWC on a second trip, the MIL will blink.
 When the misfire condition decreases to a level that will not damage the TWC, the MIL will remain on.
 If another misfire condition occurs that can damage the TWC, the MIL will begin to blink again.
- Two Trip Detection Logic (Exhaust quality deterioration)**
 For misfire conditions that will not damage the TWC (but will affect vehicle emissions), the MIL will only light when the misfire is detected on a second trip. During this condition, the ECM monitors the CKP sensor signal every 1,000 engine revolutions.
 A misfire malfunction can be detected on any one cylinder or on multiple cylinders.

DTC No.	Trouble diagnosis name	DTC detecting condition	Possible cause
P0300	Multiple cylinder misfire detected	Multiple cylinders misfire.	<ul style="list-style-type: none"> • Improper spark plug • Insufficient compression • Incorrect fuel pressure • The fuel injector circuit is open or shorted • Fuel injector • Intake air leak • The ignition signal circuit is open or shorted • Lack of fuel • Signal plate • A/F sensor 1 • Incorrect PCV hose connection
P0301	No.1 cylinder misfire detected	No. 1 cylinder misfires.	
P0302	No. 2 cylinder misfire detected	No. 2 cylinder misfires.	
P0303	No. 3 cylinder misfire detected	No. 3 cylinder misfires.	
P0304	No. 4 cylinder misfire detected	No. 4 cylinder misfires.	

DTC CONFIRMATION PROCEDURE

1.PRECONDITIONING

If DTC Confirmation Procedure has been previously conducted, always turn ignition switch OFF and wait at least 10 seconds before conducting the next test.

>> GO TO 2.

2.PERFORM DTC CONFIRMATION PROCEDURE-I

1. Start engine and warm it up to normal operating temperature.
2. Turn ignition switch OFF and wait at least 10 seconds.
3. Restart engine and let it idle for about 15 minutes.
4. Check 1st trip DTC.

Is 1st trip DTC detected?

- YES >> Go to [EC-218, "Diagnosis Procedure"](#).
- NO >> GO TO 3.

3.PERFORM DTC CONFIRMATION PROCEDURE-II

1. Turn ignition switch OFF and wait at least 10 seconds.

P0300, P0301, P0302, P0303, P0304 MISFIRE

[MR18DE]

< DTC/CIRCUIT DIAGNOSIS >

2. Start engine and drive the vehicle under the similar conditions to (1st trip) Freeze Frame Data for a certain time. Refer to the table below.

Hold the accelerator pedal as steady as possible.

The similar conditions to (1st trip) Freeze Frame Data means the vehicle operation that the following conditions should be satisfied at the same time.

CAUTION:

Always drive vehicle in safe manner according to traffic conditions and obey all traffic laws when driving.

Engine speed	Engine speed in the freeze frame data \pm 400 rpm
Vehicle speed	Vehicle speed in the freeze frame data \pm 10 km/h (6 MPH)
Base fuel schedule	Base fuel schedule in freeze frame data \times (1 \pm 0.1)
Engine coolant temperature (T) condition	When the freeze frame data shows lower than 70°C (158°F), T should be lower than 70°C (158°F).
	When the freeze frame data shows higher than or equal to 70°C (158°F), T should be higher than or equal to 70°C (158°F).

The time to driving varies according to the engine speed in the freeze frame data.

Engine speed	Time
Around 1,000 rpm	Approximately 10 minutes
Around 2,000 rpm	Approximately 5 minutes
More than 3,000 rpm	Approximately 3.5 minutes

3. Check 1st trip DTC.

Is 1st trip DTC detected?

- YES >> Go to [EC-218. "Diagnosis Procedure"](#).
NO >> INSPECTION END

Diagnosis Procedure

INFOID:00000000483329

1. CHECK FOR INTAKE AIR LEAK AND PCV HOSE

1. Start engine and run it at idle speed.
2. Listen for the sound of the intake air leak.
3. Check PCV hose connection.

Is intake air leak detected?

- YES >> Discover air leak location and repair.
NO >> GO TO 2.

2. CHECK FOR EXHAUST SYSTEM CLOGGING

Stop engine and visually check exhaust tube, three way catalyst and muffler for dents.

Is the inspection result normal?

- YES-1 >> With CONSULT-III: GO TO 3.
YES-2 >> Without CONSULT-III: GO TO 4.
NO >> Repair or replace it.

3. PERFORM POWER BALANCE TEST

 **With CONSULT-III**

1. Start engine.
2. Perform "POWER BALANCE" in "ACTIVE TEST" mode with CONSULT-III.
3. Make sure that each circuit produces a momentary engine speed drop.

Is the inspection result normal?

- YES >> GO TO 9.
NO >> GO TO 4.

4. CHECK FUNCTION OF FUEL INJECTOR

1. Start engine and let engine idle.

P0300, P0301, P0302, P0303, P0304 MISFIRE

[MR18DE]

< DTC/CIRCUIT DIAGNOSIS >

- Listen to each fuel injector operating sound.

Clicking noise should be heard.

Is the inspection result normal?

YES >> GO TO 5.

NO >> Perform trouble diagnosis for FUEL INJECTOR, refer to [EC-396. "Component Inspection"](#).

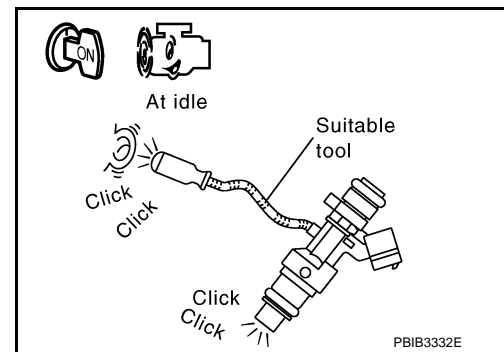

5. CHECK FUNCTION OF IGNITION COIL-I

CAUTION:

Do the following procedure in the place where ventilation is good without the combustible.

- Turn ignition switch OFF.
- Remove fuel pump fuse in IPDM E/R to release fuel pressure.

NOTE:

Do not use CONSULT-III to release fuel pressure, or fuel pressure applies again during the following procedure.

- Start engine.
- After engine stalls, crank it two or three times to release all fuel pressure.
- Turn ignition switch OFF.
- Remove all ignition coil harness connectors to avoid the electrical discharge from the ignition coils.
- Remove ignition coil and spark plug of the cylinder to be checked.
- Crank engine for 5 seconds or more to remove combustion gas in the cylinder.
- Connect spark plug and harness connector to ignition coil.
- Fix ignition coil using a rope etc. with gap of 13 - 17 mm (0.52 - 0.66 in) between the edge of the spark plug and grounded metal portion as shown in the figure.
- Crank engine for about 3 seconds, and check whether spark is generated between the spark plug and the grounded metal portion.

Spark should be generated.

CAUTION:

- During the operation, always stay 0.5 m (19.7 in) away from the spark plug and the ignition coil within. Be careful not to get an electrical shock while checking, because the electrical discharge voltage becomes 20 kV or more.
- It might cause to damage the ignition coil if the gap of more than 17 mm (0.66 in) is taken.

NOTE:

When the gap is less than 13 mm (0.52 in), the spark might be generated even if the coil is malfunctioning.

Is the inspection result normal?

YES >> GO TO 9.

NO >> GO TO 6.

6. CHECK FUNCTION OF IGNITION COIL-II

- Turn ignition switch OFF.
- Disconnect spark plug and connect a known-good spark plug.
- Crank engine for about 3 seconds, and recheck whether spark is generated between the spark plug and the grounded metal portion.

Spark should be generated.

Is the inspection result normal?

YES >> GO TO 7.

NO >> Check ignition coil, power transistor and their circuits. Refer to [EC-401. "Component Function Check"](#).

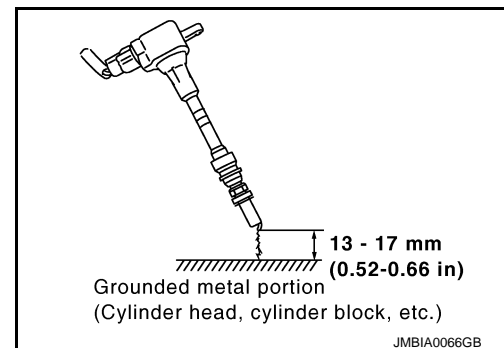

< DTC/CIRCUIT DIAGNOSIS >

7.CHECK SPARK PLUG

Check the initial spark plug for fouling, etc.

Is the inspection result normal?

- YES >> Replace spark plug(s) with standard type one(s). For spark plug type, refer to [EM-113, "Spark Plug"](#).
- NO >> Repair or clean spark plug. Then GO TO 8.

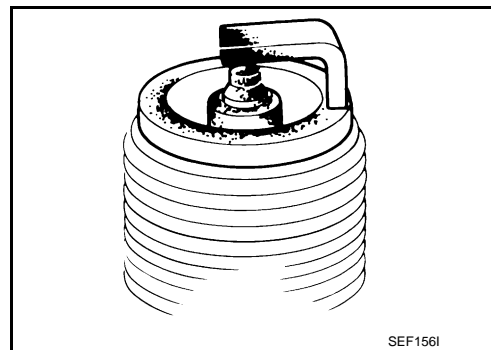
**8.CHECK FUNCTION OF IGNITION COIL-III**

1. Reconnect the initial spark plugs.
2. Crank engine for about 3 seconds, and recheck whether spark is generated between the spark plug and the grounded portion.

Spark should be generated.Is the inspection result normal?

- YES >> INSPECTION END
- NO >> Replace spark plug(s) with standard type one(s). For spark plug type, refer to [EM-113, "Spark Plug"](#).

9.CHECK COMPRESSION PRESSURECheck compression pressure. Refer to [EM-21, "Inspection"](#).Is the inspection result normal?

- YES >> GO TO 10.
- NO >> Check pistons, piston rings, valves, valve seats and cylinder head gaskets.

10.CHECK FUEL PRESSURE

1. Install all removed parts.
2. Check fuel pressure. Refer to [EC-471, "Inspection"](#).

Is the inspection result normal?

- YES >> GO TO 12.
- NO >> GO TO 11.

11.DETECT MALFUNCTIONING PART

Check fuel hoses and fuel tubes for clogging.

Is the inspection result normal?

- YES >> Replace "fuel filter and fuel pump assembly".
- NO >> Repair or replace.

12.CHECK IGNITION TIMINGCheck the following items. Refer to [EC-12, "BASIC INSPECTION : Special Repair Requirement"](#). For specification, refer to [EC-477, "Ignition Timing"](#).Is the inspection result normal?

- YES >> GO TO 13.
- NO >> Follow the [EC-12, "BASIC INSPECTION : Special Repair Requirement"](#).

13.CHECK A/F SENSOR 1 INPUT SIGNAL CIRCUIT

1. Turn ignition switch OFF.
2. Disconnect corresponding A/F sensor 1 harness connector.
3. Disconnect ECM harness connector.
4. Check the continuity between A/F sensor 1 harness connector and ECM harness connector.

P0300, P0301, P0302, P0303, P0304 MISFIRE

< DTC/CIRCUIT DIAGNOSIS >

[MR18DE]

A/F sensor 1		ECM		Continuity
Connector	Terminal	Connector	Terminal	
F50	1	F8	49	Existed
	2		53	

5. Check the continuity between A/F sensor 1 harness connector and ground, or ECM harness connector and ground.

A/F sensor 1		Ground	Continuity
Connector	Terminal		
F50	1	Ground	Not existed
	2		

ECM		Ground	Continuity
Connector	Terminal		
F8	49	Ground	Not existed
	53		

6. Also check harness for short to power.

Is the inspection result normal?

YES >> GO TO 14.

NO >> Repair open circuit or short to ground or short to power in harness or connectors.

14.CHECK A/F SENSOR 1 HEATER

Refer to [EC-129, "Component Inspection"](#).

Is the inspection result normal?

YES >> GO TO 15.

NO >> Replace A/F sensor 1.

15.CHECK MASS AIR FLOW SENSOR

With CONSULT-III

Check "MASS AIR FLOW" in "DATA MONITOR" mode with CONSULT-III.

For specification, refer to [EC-477, "Mass Air Flow Sensor"](#).

With GST

Check mass air flow sensor signal in Service \$01 with GST.

For specification, refer to [EC-477, "Mass Air Flow Sensor"](#).

Is the measurement value within the specification?

YES >> GO TO 16.

NO >> Check connectors for rusted terminals or loose connections in the mass air flow sensor circuit or ground. Refer to [EC-136, "DTC Logic"](#).

16.CHECK SYMPTOM TABLE

Check items on the rough idle symptom in [EC-460, "Symptom Table"](#).

Is the inspection result normal?

YES >> GO TO 17.

NO >> Repair or replace.

17.ERASE THE 1ST TRIP DTC

Some tests may cause a 1st trip DTC to be set.

Erase the 1st trip DTC from the ECM memory after performing the tests. Refer to "How to Erase DTC and 1st Trip DTC" in [EC-85, "Diagnosis Description"](#).

>> GO TO 18.

P0300, P0301, P0302, P0303, P0304 MISFIRE

< DTC/CIRCUIT DIAGNOSIS >

[MR18DE]

18.CHECK INTERMITTENT INCIDENT

Refer to [GI-34, "Intermittent Incident"](#).

>> INSPECTION END

P0327, P0328 KS

Description

INFOID:000000004833330

The knock sensor is attached to the cylinder block. It senses engine knocking using a piezoelectric element. A knocking vibration from the cylinder block is sensed as vibrational pressure. This pressure is converted into a voltage signal and sent to the ECM.

DTC Logic

INFOID:000000004833331

DTC DETECTION LOGIC

DTC No.	Trouble diagnosis name	DTC detected condition	Possible cause
P0327	Knock sensor circuit low input	An excessively low voltage from the sensor is sent to ECM.	<ul style="list-style-type: none"> • Harness or connectors (The sensor circuit is open or shorted.) • Knock sensor
P0328	Knock sensor circuit high input	An excessively high voltage from the sensor is sent to ECM.	

DTC CONFIRMATION PROCEDURE

1. PRECONDITIONING

If DTC Confirmation Procedure has been previously conducted, always turn ignition switch OFF and wait at least 10 seconds before conducting the next test.

TESTING CONDITION:

Before performing the following procedure, confirm that battery voltage is more than 10 V at idle.

>> GO TO 2.

2. PERFORM DTC CONFIRMATION PROCEDURE

1. Start engine and run it for at least 5 seconds at idle speed.
2. Check 1st trip DTC.

Is 1st trip DTC detected?

- YES >> Go to [EC-223, "Diagnosis Procedure"](#).
- NO >> INSPECTION END

Diagnosis Procedure

INFOID:000000004833333

1. CHECK GROUND CONNECTION

1. Turn ignition switch OFF.
2. Check ground connection E38. Refer to [GI-37, "Circuit Inspection"](#).

Is the inspection result normal?

- YES >> GO TO 2.
- NO >> Repair or replace ground connection.

2. CHECK KNOCK SENSOR GROUND CIRCUIT FOR OPEN AND SHORT

1. Disconnect knock sensor harness connector.
2. Disconnect ECM harness connector.
3. Check the continuity between knock sensor harness connector and ECM harness connector.

Knock sensor		ECM		Continuity
Connector	Terminal	Connector	Terminal	
F12	2	F8	40	Existed

4. Also check harness for short to ground and short to power.

Is the inspection result normal?

- YES >> GO TO 3.
- NO >> Repair open circuit or short to ground or short to power in harness or connectors.

< DTC/CIRCUIT DIAGNOSIS >

3.CHECK KNOCK SENSOR INPUT SIGNAL CIRCUIT FOR OPEN AND SHORT

1. Check the continuity between knock sensor harness connector and ECM harness connector.

Knock sensor		ECM		Continuity
Connector	Terminal	Connector	Terminal	
F12	1	F8	37	Existed

2. Also check harness for short to ground and short to power.

Is the inspection result normal?

YES >> GO TO 4.

NO >> Repair open circuit or short to ground or short to power in harness or connectors.

4.CHECK KNOCK SENSOR

Refer to [EC-224, "Component Inspection"](#).

Is the inspection result normal?

YES >> GO TO 5.

NO >> Replace knock sensor.

5.CHECK INTERMITTENT INCIDENT

Refer to [GI-34, "Intermittent Incident"](#).

>> INSPECTION END

Component Inspection

INFOID:000000004833334

1.CHECK KNOCK SENSOR

1. Turn ignition switch OFF.
2. Disconnect knock sensor harness connector.
3. Check resistance between knock sensor terminals as per the following.

NOTE:

It is necessary to use an ohmmeter which can measure more than 10 MΩ.

Terminals	Resistance
1 and 2	Approx. 532 - 588 kΩ [at 20°C (68°F)]

CAUTION:

Do not use any knock sensors that have been dropped or physically damaged. Use only new ones.

Is the inspection result normal?

YES >> INSPECTION END

NO >> Replace knock sensor.

P0335 CKP SENSOR (POS)

< DTC/CIRCUIT DIAGNOSIS >

[MR18DE]

P0335 CKP SENSOR (POS)

Description

INFOID:000000004833335

The crankshaft position sensor (POS) is located on the oil pan facing the gear teeth (cogs) of the signal plate. It detects the fluctuation of the engine revolution.

The sensor consists of a permanent magnet and Hall IC.

When the engine is running, the high and low parts of the teeth cause the gap with the sensor to change.

The changing gap causes the magnetic field near the sensor to change.

Due to the changing magnetic field, the voltage from the sensor changes.

The ECM receives the voltage signal and detects the fluctuation of the engine revolution.

ECM receives the signals as shown in the figure.

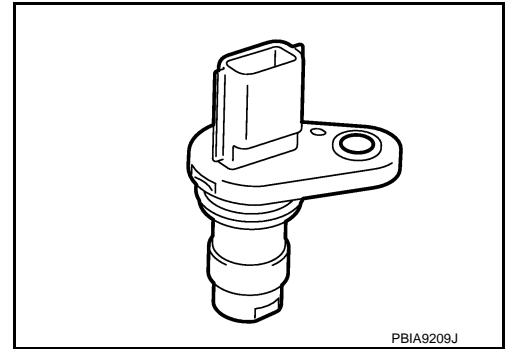

PBIA9209J

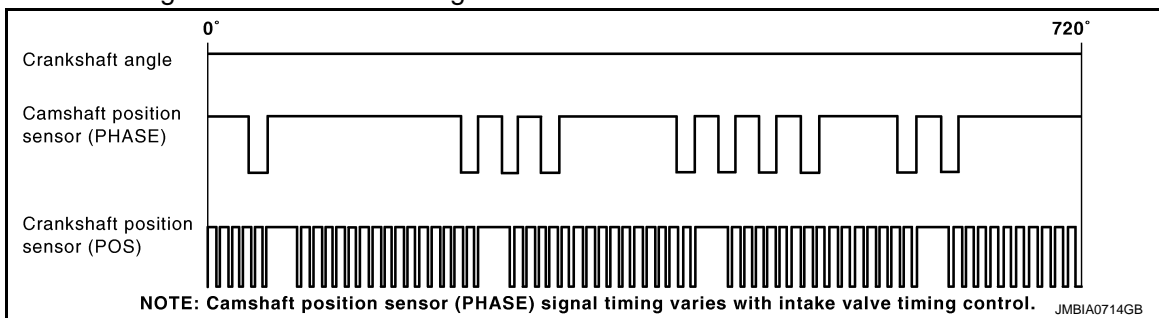

DTC Logic

INFOID:000000004833336

DTC DETECTION LOGIC

DTC No.	Trouble diagnosis name	DTC detecting condition	Possible cause
P0335	Crankshaft position sensor (POS) circuit	<ul style="list-style-type: none"> The crankshaft position sensor (POS) signal is not detected by the ECM during the first few seconds of engine cranking. The proper pulse signal from the crankshaft position sensor (POS) is not sent to ECM while the engine is running. The crankshaft position sensor (POS) signal is not in the normal pattern during engine running. 	<ul style="list-style-type: none"> Harness or connectors [Crankshaft position sensor (POS) circuit is open or shorted.] (Refrigerant pressure sensor circuit is shorted.) (Accelerator pedal position sensor circuit is shorted.) (EVAP control system pressure sensor circuit is shorted.) (Battery current sensor circuit is shorted.) Crankshaft position sensor (POS) Refrigerant pressure sensor Accelerator pedal position sensor EVAP control system pressure sensor Signal plate Battery current sensor

DTC CONFIRMATION PROCEDURE

1. PRECONDITIONING

If DTC Confirmation Procedure has been previously conducted, always turn ignition switch OFF and wait at least 10 seconds before conducting the next test.

TESTING CONDITION:

Before performing the following procedure, confirm that battery voltage is more than 10.5 V with ignition switch ON.

>> GO TO 2.

P0335 CKP SENSOR (POS)

[MR18DE]

< DTC/CIRCUIT DIAGNOSIS >

2. PERFORM DTC CONFIRMATION PROCEDURE

1. Start engine and let it idle for at least 5 seconds.
If engine does not start, crank engine for at least 2 seconds.
2. Check 1st trip DTC.

Is 1st trip DTC detected?

- YES >> Go to [EC-226. "Diagnosis Procedure"](#).
NO >> INSPECTION END

Diagnosis Procedure

INFOID:00000000483338

1. CHECK GROUND CONNECTION

1. Turn ignition switch OFF.
2. Check ground connection E38. Refer to [GI-37. "Circuit Inspection"](#).

Is the inspection result normal?

- YES >> GO TO 2.
NO >> Repair or replace ground connection.

2. CHECK CRANKSHAFT POSITION (CKP) SENSOR (POS) POWER SUPPLY CIRCUIT-I

1. Disconnect crankshaft position (CKP) sensor (POS) harness connector.
2. Turn ignition switch ON.
3. Check the voltage between CKP sensor (POS) harness connector and ground.

CKP sensor (POS)		Ground	Voltage
Connector	Terminal		
F20	1	Ground	Approx. 5 V

Is the inspection result normal?

- YES >> GO TO 8.
NO >> GO TO 3.

3. CHECK CKP SENSOR (POS) POWER SUPPLY CIRCUIT-II

1. Turn ignition switch ON.
2. Disconnect ECM harness connector.
3. Check the continuity between CKP sensor (POS) harness connector and ECM harness connector.

CKP sensor (POS)		ECM		Continuity
Connector	Terminal	Connector	Terminal	
F20	1	F8	75	Existed

Is the inspection result normal?

- YES >> GO TO 4.
NO >> Repair open circuit.

4. CHECK CKP SENSOR POWER SUPPLY CIRCUIT

Check harness for short to power and short to ground, between the following terminals.

ECM		Sensor		
Connector	Terminal	Name	Connector	Terminal
F8	74	Refrigerant pressure sensor	E49	3
	75	CKP sensor (POS)	F20	1
	76	EVAP control system pressure sensor	B21	3
	77	Battery current sensor	F51	1
E16	102	APP sensor	E110	5

P0335 CKP SENSOR (POS)

[MR18DE]

< DTC/CIRCUIT DIAGNOSIS >

Is the inspection result normal?

- YES >> GO TO 5.
NO >> Repair short to ground or short to power in harness or connectors.

5.CHECK COMPONENTS

Check the following.

- Battery current sensor (Refer to [EC-327, "Component Inspection"](#).)
- EVAP control system pressure sensor (Refer to [EC-269, "Component Inspection"](#).)
- Refrigerant pressure sensor (Refer to [EC-414, "Diagnosis Procedure"](#).)

Is the inspection result normal?

- YES >> GO TO 6.
NO >> Replace malfunctioning components.

6.CHECK APP SENSOR

Refer to [EC-370, "Component Inspection"](#).

Is the inspection result normal?

- YES >> GO TO 12.
NO >> GO TO 7.

7.REPLACE ACCELERATOR PEDAL ASSEMBLY

1. Replace accelerator pedal assembly.
2. Perform [EC-370, "Special Repair Requirement"](#).

>> INSPECTION END

8.CHECK CKP SENSOR (POS) GROUND CIRCUIT FOR OPEN AND SHORT

1. Turn ignition switch OFF.
2. Check the continuity between CKP sensor (POS) harness connector and ECM harness connector.

CKP sensor (POS)		ECM		Continuity
Connector	Terminal	Connector	Terminal	
F20	2	F8	62	Existed

3. Also check harness for short to ground and short to power.

Is the inspection result normal?

- YES >> GO TO 9.
NO >> Repair open circuit or short to ground or short to power in harness or connectors.

9.CHECK CKP SENSOR (POS) INPUT SIGNAL CIRCUIT FOR OPEN AND SHORT

1. Disconnect ECM harness connector.
2. Check the continuity between CKP sensor (POS) harness connector and ECM harness connector.

CKP sensor (POS)		ECM		Continuity
Connector	Terminal	Connector	Terminal	
F20	3	F8	61	Existed

3. Also check harness for short to ground and short to power.

Is the inspection result normal?

- YES >> GO TO 10.
NO >> Repair open circuit or short to ground or short to power in harness or connectors.

10.CHECK CRANKSHAFT POSITION SENSOR (POS)

Refer to [EC-228, "Component Inspection"](#).

Is the inspection result normal?

- YES >> GO TO 11.
NO >> Replace crankshaft position sensor (POS).

P0335 CKP SENSOR (POS)

[MR18DE]

< DTC/CIRCUIT DIAGNOSIS >

11. CHECK GEAR TOOTH

Visually check for chipping signal plate gear tooth.

Is the inspection result normal?

YES >> GO TO 12.

NO >> Replace the signal plate.

12. CHECK INTERMITTENT INCIDENT

Refer to [GI-34, "Intermittent Incident"](#).

>> INSPECTION END

Component Inspection

INFOID:000000004833339

1. CHECK CRANKSHAFT POSITION SENSOR (POS)-I

1. Turn ignition switch OFF.
2. Loosen the fixing bolt of the sensor.
3. Disconnect crankshaft position sensor (POS) harness connector.
4. Remove the sensor.
5. Visually check the sensor for chipping.

Is the inspection result normal?

YES >> GO TO 2.

NO >> Replace crankshaft position sensor (POS).

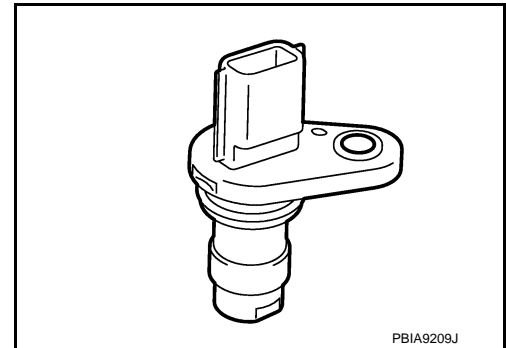

2. CHECK CRANKSHAFT POSITION SENSOR (POS)-II

Check resistance between crankshaft position sensor (POS) terminals as per the following.

Terminals (Polarity)	Resistance [Ω at 25°C (77°F)]
1 (+) - 2 (-)	Except 0 or ∞
1 (+) - 3 (-)	
2 (+) - 3 (-)	

Is the inspection result normal?

YES >> INSPECTION END

NO >> Replace crankshaft position sensor (POS).

P0340 CMP SENSOR (PHASE)

< DTC/CIRCUIT DIAGNOSIS >

[MR18DE]

P0340 CMP SENSOR (PHASE)

Description

INFOID:000000004833340

The camshaft position sensor (PHASE) senses the retraction of camshaft (INT) to identify a particular cylinder. The camshaft position sensor (PHASE) senses the piston position.

When the crankshaft position sensor (POS) system becomes inoperative, the camshaft position sensor (PHASE) provides various controls of engine parts instead, utilizing timing of cylinder identification signals.

The sensor consists of a permanent magnet and Hall IC.

When engine is running, the high and low parts of the teeth cause the gap with the sensor to change.

The changing gap causes the magnetic field near the sensor to change.

Due to the changing magnetic field, the voltage from the sensor changes. ECM receives the signals as shown in the figure.

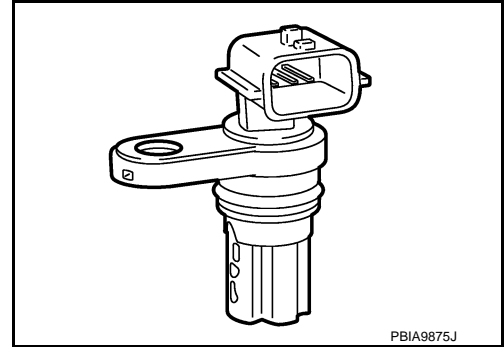

PBIA9875J

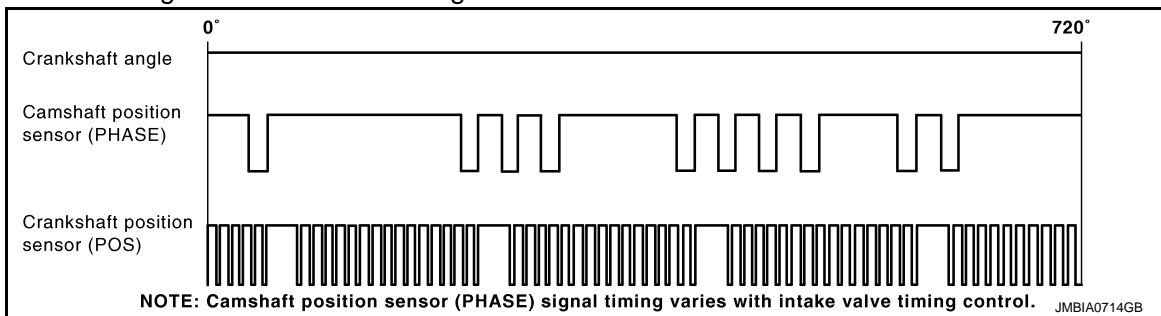

DTC Logic

INFOID:000000004833341

DTC DETECTION LOGIC

NOTE:

If DTC P0340 is displayed with DTC P0643, first perform the trouble diagnosis for DTC P0643. Refer to [EC-308, "DTC Logic"](#).

DTC No.	Trouble diagnosis name	DTC detecting condition	Possible cause
P0340	Camshaft position sensor (PHASE) circuit	<ul style="list-style-type: none"> The cylinder No. signal is not sent to ECM for the first few seconds during engine cranking. The cylinder No. signal is not sent to ECM during engine running. The cylinder No. signal is not in the normal pattern during engine running. 	<ul style="list-style-type: none"> Harness or connectors (The sensor circuit is open or shorted) Camshaft position sensor (PHASE) Camshaft (INT) Starter motor Starting system circuit Dead (Weak) battery

DTC CONFIRMATION PROCEDURE

1. PRECONDITIONING

If DTC Confirmation Procedure has been previously conducted, always turn ignition switch OFF and wait at least 10 seconds before conducting the next test.

TESTING CONDITION:

Before performing the following procedure, confirm that battery voltage is more than 10.5 V with ignition switch ON.

>> GO TO 2.

2. PERFORM DTC CONFIRMATION PROCEDURE-I

- Start engine and let it idle for at least 5 seconds.
If engine does not start, crank engine for at least 2 seconds.
- Check 1st trip DTC.

P0340 CMP SENSOR (PHASE)

[MR18DE]

< DTC/CIRCUIT DIAGNOSIS >

Is 1st trip DTC detected?

- YES >> Go to [EC-230, "Diagnosis Procedure"](#).
- NO >> GO TO 3.

3.PERFORM DTC CONFIRMATION PROCEDURE-I

1. Maintaining engine speed at more than 800 rpm for at least 5 seconds.
2. Check 1st trip DTC.

Is 1st trip DTC detected?

- YES >> Go to [EC-230, "Diagnosis Procedure"](#).
- NO >> INSPECTION END

Diagnosis Procedure

INFOID:000000004833343

1.CHECK STARTING SYSTEM

Turn ignition switch to START position.

Does the engine turn over? Does the starter motor operate?

- YES >> GO TO 2.
- NO >> Check starting system (Refer to [STR-2, "Work Flow"](#)).

2.CHECK GROUND CONNECTION

1. Turn ignition switch OFF.
2. Check ground connection E38. Refer to [GI-37, "Circuit Inspection"](#).

Is the inspection result normal?

- YES >> GO TO 3.
- NO >> Repair or replace ground connection.

3.CHECK CAMSHAFT POSITION (CMP) SENSOR (PHASE) POWER SUPPLY CIRCUIT

1. Disconnect camshaft position (CMP) sensor (PHASE) harness connector.
2. Turn ignition switch ON.
3. Check the voltage between CMP sensor (PHASE) harness connector and ground.

CMP sensor (PHASE)		Ground	Voltage
Connector	Terminal		
F26	1	Ground	Approx. 5 V

Is the inspection result normal?

- YES >> GO TO 4.
- NO >> Repair open circuit or short to ground or short to power in harness or connectors.

4.CHECK CMP SENSOR (PHASE) GROUND CIRCUIT FOR OPEN AND SHORT

1. Turn ignition switch OFF.
2. Check the continuity between CMP sensor (PHASE) harness connector and ECM harness connector.

CMP sensor (PHASE)		ECM		Continuity
Connector	Terminal	Connector	Terminal	
F26	2	F8	63	Existed

3. Also check harness for short to power.

Is the inspection result normal?

- YES >> GO TO 5.
- NO >> Repair open circuit or short to ground or short to power in harness or connectors.

5.CHECK CMP SENSOR (PHASE) INPUT SIGNAL CIRCUIT FOR OPEN AND SHORT

1. Disconnect ECM harness connector.
2. Check the continuity between CMP sensor (PHASE) harness connector and ECM harness connector.

P0340 CMP SENSOR (PHASE)

[MR18DE]

< DTC/CIRCUIT DIAGNOSIS >

CMP sensor (PHASE)		ECM		Continuity
Connector	Terminal	Connector	Terminal	
F26	3	F8	65	Existed

3. Also check harness for short to ground and short to power.

Is the inspection result normal?

YES >> GO TO 6.

NO >> Repair open circuit or short to ground or short to power in harness or connectors.

6.CHECK CAMSHAFT POSITION SENSOR (PHASE)

Refer to [EC-231](#), "[Component Inspection](#)".

Is the inspection result normal?

YES >> GO TO 7.

NO >> Replace camshaft position sensor (PHASE).

7.CHECK CAMSHAFT (INT)

Check the following.

- Accumulation of debris to the signal plate of camshaft (1) rear end
- Chipping signal plate of camshaft rear end

Is the inspection result normal?

YES >> GO TO 8.

NO >> Remove debris and clean the signal plate of camshaft rear end or replace camshaft.

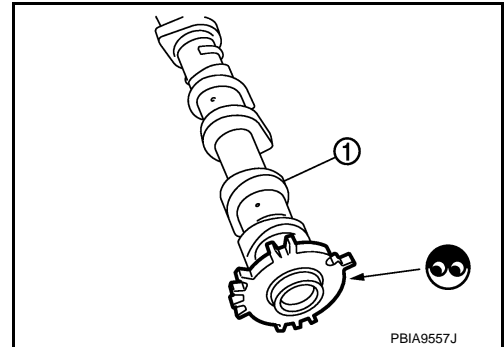

8.CHECK INTERMITTENT INCIDENT

Refer to [GI-34](#), "[Intermittent Incident](#)".

>> INSPECTION END

Component Inspection

INFOID:000000004833344

1.CHECK CAMSHAFT POSITION SENSOR (PHASE)-I

1. Turn ignition switch OFF.
2. Loosen the fixing bolt of the sensor.
3. Disconnect camshaft position sensor (PHASE) harness connector.
4. Remove the sensor.
5. Visually check the sensor for chipping.

Is the inspection result normal?

YES >> GO TO 2.

NO >> Replace camshaft position sensor (PHASE).

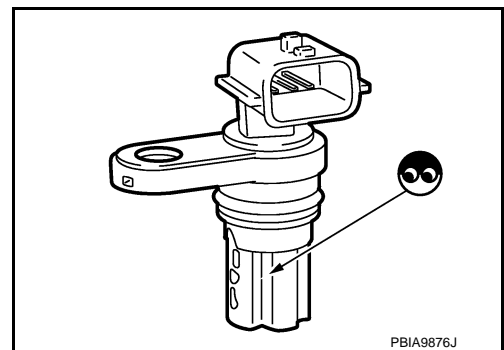

2.CHECK CAMSHAFT POSITION SENSOR (PHASE)-II

Check resistance camshaft position sensor (PHASE) terminals as per the following.

P0340 CMP SENSOR (PHASE)

< DTC/CIRCUIT DIAGNOSIS >

[MR18DE]

Terminals (Polarity)	Resistance [Ω at 25°C (77°F)]
1 (+) - 2 (-)	Except 0 or ∞
1 (+) - 3 (-)	
2 (+) - 3 (-)	

Is the inspection result normal?

YES >> INSPECTION END

NO >> Replace camshaft position sensor (PHASE).

P0420 THREE WAY CATALYST FUNCTION

< DTC/CIRCUIT DIAGNOSIS >

[MR18DE]

P0420 THREE WAY CATALYST FUNCTION

DTC Logic

INFOID:000000004833345

DTC DETECTION LOGIC

The ECM monitors the switching frequency ratio of air fuel ratio (A/F) sensor 1 and heated oxygen sensor 2.

A three way catalyst (manifold) with high oxygen storage capacity will indicate a low switching frequency of heated oxygen sensor 2. As oxygen storage capacity decreases, the heated oxygen sensor 2 switching frequency will increase.

When the frequency ratio of A/F sensor 1 and heated oxygen sensor 2 approaches a specified limit value, the three way catalyst (manifold) malfunction is diagnosed.

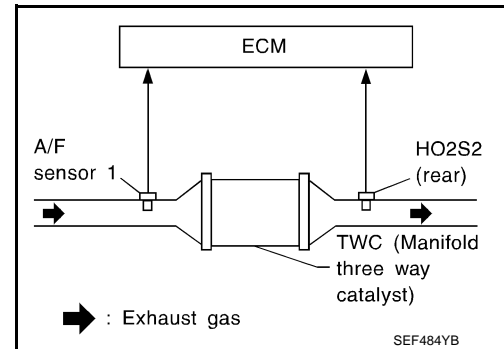

DTC No.	Trouble diagnosis name	DTC detecting condition	Possible cause
P0420	Catalyst system efficiency below threshold	<ul style="list-style-type: none"> Three way catalyst (manifold) does not operate properly. Three way catalyst (manifold) does not have enough oxygen storage capacity. 	<ul style="list-style-type: none"> Three way catalyst (manifold) Exhaust tube Intake air leaks Fuel injector Fuel injector leaks Spark plug Improper ignition timing

DTC CONFIRMATION PROCEDURE

1.INSPECTION START

Do you have CONSULT-III?

Do you have CONSULT-III?

YES >> GO TO 2.

NO >> GO TO 7.

2.PRECONDITIONING

If DTC Confirmation Procedure has been previously conducted, always turn ignition switch OFF and wait at least 10 seconds before conducting the next test.

TESTING CONDITION:

Do not hold engine speed for more than the specified minutes below.

>> GO TO 3.

3.PERFORM DTC CONFIRMATION PROCEDURE-I

Ⓜ With CONSULT-III

- Turn ignition switch ON and select "DATA MONITOR" mode with CONSULT-III.
- Start engine and warm it up to normal operating temperature.
- Turn ignition switch OFF and wait at least 10 seconds.
- Start engine and keep the engine speed between 3,500 and 4,000 rpm for at least 1 minute under no load.
- Let engine idle for 1 minute.
- Make sure that "COOLAN TEMP/S" indication is more than 70°C (158°F).
If not, warm up engine and go to next step when "COOLAN TEMP/S" indication reaches 70°C (158°F).
- Open engine hood.
- Select "DTC & SRT CONFIRMATION" then "SRT WORK SUPPORT" mode with CONSULT-III.
- Rev engine up to 2,000 to 3,000 rpm and hold it for 3 consecutive minutes then release the accelerator pedal completely.
- Check the indication of "CATALYST".

Which is displayed on CONSULT-III screen?

P0420 THREE WAY CATALYST FUNCTION

[MR18DE]

< DTC/CIRCUIT DIAGNOSIS >

- CMPLT >> GO TO 6.
- INCMP >> GO TO 4.

4.PERFORM DTC CONFIRMATION PROCEDURE-II

1. Wait 5 seconds at idle.
2. Rev engine up to 2,000 to 3,000 rpm and maintain it until "INCMP" of "CATALYST" changes to "CMPLT" (It will take approximately 5 minutes).

Does the indication change to "CMPLT"?

- YES >> GO TO 6.
- NO >> GO TO 5.

5.PERFORM DTC CONFIRMATION PROCEDURE AGAIN

1. Stop engine and cool it down to less than 70°C (158°F).
2. Perform DTC CONFIRMATION PROCEDURE again.

>> GO TO 3.

6.PERFORM DTC CONFIRMATION PROCEDURE-III

Check 1st trip DTC.

Is 1st trip DTC detected?

- YES >> Go to [EC-234, "Diagnosis Procedure"](#).
- NO >> INSPECTION END

7.PERFORM COMPONENT FUNCTION CHECK

Perform component function check. Refer to [EC-234, "Component Function Check"](#).

NOTE:

Use component function check to check the overall function of the three way catalyst (manifold). During this check, a 1st trip DTC might not be confirmed.

Is the inspection result normal?

- YES >> INSPECTION END
- NO >> Go to [EC-234, "Diagnosis Procedure"](#).

Component Function Check

INFOID:000000004833346

1.PERFORM COMPONENT FUNCTION CHECK

⊗ Without CONSULT-III

1. Start engine and warm it up to normal operating temperature.
2. Turn ignition switch OFF and wait at least 10 seconds.
3. Start engine and keep the engine speed between 3,500 and 4,000 rpm for at least 1 minute under no load.
4. Let engine idle for 1 minute.
5. Open engine hood.
6. Check the voltage between ECM harness connector and ground under the following condition.

ECM		Ground	Condition	Voltage
Connector	Terminal			
F8	50 (HO2S2 signal)	Ground	Keeping engine speed at 2,500 rpm constant under no load	The voltage fluctuation cycle takes more than 5 seconds. 1 cycle: 0.6 - 1.0 → 0 - 0.3 → 0.6 - 1.0

Is the inspection result normal?

- YES >> INSPECTION END
- NO >> Go to [EC-234, "Diagnosis Procedure"](#).

Diagnosis Procedure

INFOID:000000004833347

1.CHECK EXHAUST SYSTEM

Visually check exhaust tubes and muffler for dent.

P0420 THREE WAY CATALYST FUNCTION

[MR18DE]

< DTC/CIRCUIT DIAGNOSIS >

Is the inspection result normal?

- YES >> GO TO 2.
- NO >> Repair or replace.

2.CHECK EXHAUST GAS LEAK

1. Start engine and run it at idle.
2. Listen for an exhaust gas leak before the three way catalyst (manifold).

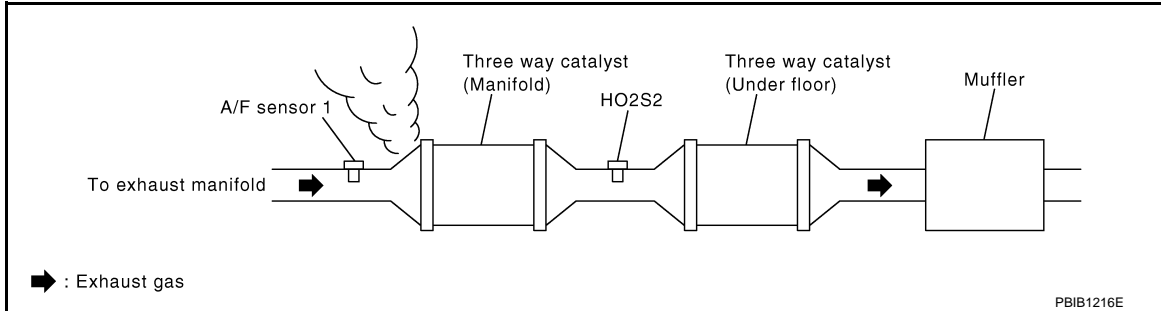

Is exhaust gas leak detected?

- YES >> Repair or replace.
- NO >> GO TO 3.

3.CHECK INTAKE AIR LEAK

Listen for an intake air leak after the mass air flow sensor.

Is intake air leak detected?

- YES >> Repair or replace.
- NO >> GO TO 4.

4.CHECK IDLE SPEED AND IGNITION TIMING

For procedure, refer to [EC-16, "IGNITION TIMING : Special Repair Requirement"](#).
For specification, refer to [EC-477, "Idle Speed"](#) and [EC-477, "Ignition Timing"](#).

Is the inspection result normal?

- YES >> GO TO 5.
- NO >> Follow the instruction of [EC-12, "BASIC INSPECTION : Special Repair Requirement"](#).

5.CHECK FUEL INJECTOR

1. Stop engine and then turn ignition switch ON.
2. Check the voltage between ECM harness connector and ground.

ECM		Ground	Voltage
Connector	Terminal		
F7	25	Ground	Battery voltage
	29		
	30		
	31		

Is the inspection result normal?

- YES >> GO TO 6.
- NO >> Perform [EC-395, "Diagnosis Procedure"](#).

6.CHECK FUNCTION OF IGNITION COIL-I

CAUTION:

Do the following procedure in the place where ventilation is good without the combustible.

1. Turn ignition switch OFF.
2. Remove fuel pump fuse in IPDM E/R to release fuel pressure.

NOTE:

Do not use CONSULT-III to release fuel pressure, or fuel pressure applies again during the following procedure.

P0420 THREE WAY CATALYST FUNCTION

[MR18DE]

< DTC/CIRCUIT DIAGNOSIS >

3. Start engine.
4. After engine stalls, crank it two or three times to release all fuel pressure.
5. Turn ignition switch OFF.
6. Remove all ignition coil harness connectors to avoid the electrical discharge from the ignition coils.
7. Remove ignition coil and spark plug of the cylinder to be checked.
8. Crank engine for 5 seconds or more to remove combustion gas in the cylinder.
9. Connect spark plug and harness connector to ignition coil.
10. Fix ignition coil using a rope etc. with gap of 13 - 17 mm (0.52 - 0.66 in) between the edge of the spark plug and grounded metal portion as shown in the figure.
11. Crank engine for about 3 seconds, and check whether spark is generated between the spark plug and the grounded metal portion.

Spark should be generated.

CAUTION:

- During the operation, always stay 0.5 m (19.7 in) away from the spark plug and the ignition coil. Be careful not to get an electrical shock while checking, because the electrical discharge voltage becomes 20 kV or more.
- It might cause to damage the ignition coil if the gap of more than 17 mm (0.66 in) is taken.

NOTE:

When the gap is less than 13 mm (0.52 in), the spark might be generated even if the coil is malfunctioning.

Is the inspection result normal?

- YES >> GO TO 10.
NO >> GO TO 7.

7. CHECK FUNCTION OF IGNITION COIL-II

1. Turn ignition switch OFF.
2. Disconnect spark plug and connect a known-good spark plug.
3. Crank engine for about 3 seconds, and recheck whether spark is generated between the spark plug and the grounded metal portion.

Spark should be generated.

Is the inspection result normal?

- YES >> GO TO 8.
NO >> Check ignition coil, power transistor and their circuits. Refer to [EC-401. "Diagnosis Procedure"](#).

8. CHECK SPARK PLUG

Check the initial spark plug for fouling, etc.

Is the inspection result normal?

- YES >> Replace spark plug(s) with standard type one(s). For spark plug type, refer to [EM-113. "Spark Plug"](#).
NO >> Repair or clean spark plug. Then GO TO 9.

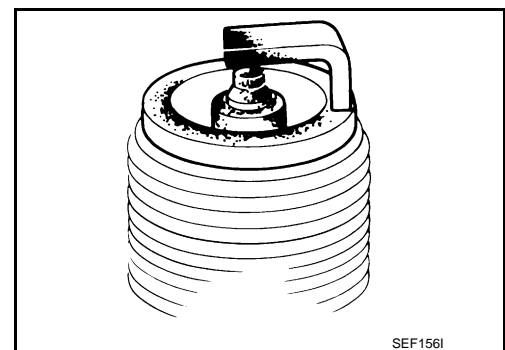
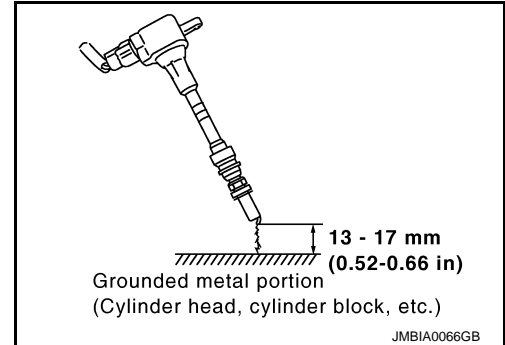

9. CHECK FUNCTION OF IGNITION COIL-III

1. Reconnect the initial spark plugs.
2. Crank engine for about three seconds, and recheck whether spark is generated between the spark plug and the grounded portion.

Spark should be generated.

P0420 THREE WAY CATALYST FUNCTION

[MR18DE]

< DTC/CIRCUIT DIAGNOSIS >

Is the inspection result normal?

YES >> INSPECTION END

NO >> Replace spark plug(s) with standard type one(s). For spark plug type, refer to [EM-113. "Spark Plug"](#).

10.CHECK FUEL INJECTOR

1. Turn ignition switch OFF. Refer to [EM-35. "Removal and Installation"](#).

2. Remove fuel injector assembly.

Keep fuel hose and all fuel injectors connected to fuel tube.

3. Disconnect all ignition coil harness connectors.

4. Reconnect all fuel injector harness connectors disconnected.

5. Turn ignition switch ON.

Does fuel drip from fuel injector?

YES >> GO TO 11.

NO >> Replace the fuel injector(s) from which fuel is dripping.

11.CHECK INTERMITTENT INCIDENT

Refer to [GI-34. "Intermittent Incident"](#).

Is the inspection result normal?

YES >> Replace three way catalyst assembly.

NO >> Repair or replace harness or connector

A

EC

C

D

E

F

G

H

I

J

K

L

M

N

O

P

P0441 EVAP CONTROL SYSTEM

< DTC/CIRCUIT DIAGNOSIS >

[MR18DE]

P0441 EVAP CONTROL SYSTEM

DTC Logic

INFOID:000000004833348

DTC DETECTION LOGIC

NOTE:

If DTC P0441 is displayed with other DTC such as P2122, P2123, P2127, P2128 or P2138, first perform trouble diagnosis for other DTC.

In this evaporative emission (EVAP) control system, purge flow occurs during non-closed throttle conditions. Purge volume is related to air intake volume. Under normal purge conditions (non-closed throttle), the EVAP canister purge volume control solenoid valve is open to admit purge flow. Purge flow exposes the EVAP control system pressure sensor to intake manifold vacuum.

Under normal conditions (non-closed throttle), sensor output voltage indicates if pressure drop and purge flow are adequate. If not, a malfunction is determined.

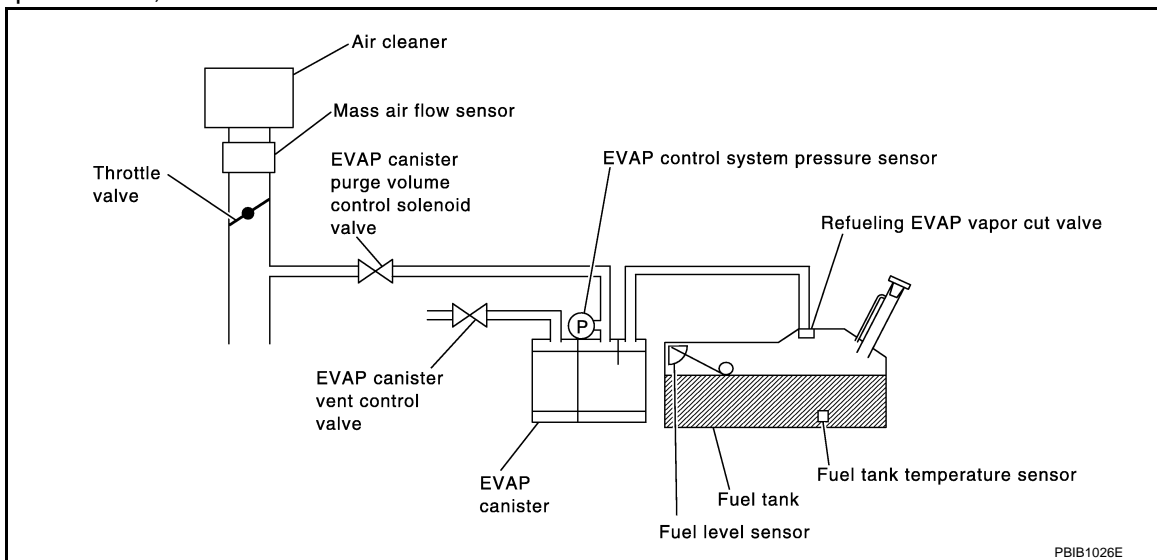

DTC No.	Trouble diagnosis name	DTC detecting condition	Possible cause
P0441	EVAP control system incorrect purge flow	EVAP control system does not operate properly, EVAP control system has a leak between intake manifold and EVAP control system pressure sensor.	<ul style="list-style-type: none"> • EVAP canister purge volume control solenoid valve stuck closed • EVAP control system pressure sensor and the circuit • Loose, disconnected or improper connection of rubber tube • Blocked rubber tube • Cracked EVAP canister • EVAP canister purge volume control solenoid valve circuit • Accelerator pedal position sensor • Blocked purge port • EVAP canister vent control valve • Drain filter

DTC CONFIRMATION PROCEDURE

1. INSPECTION START

Do you have CONSULT-III?

Do you have CONSULT-III?

YES >> GO TO 2.

NO >> GO TO 6.

2. PRECONDITIONING

If DTC Confirmation Procedure has been previously conducted, always turn ignition switch OFF and wait at least 10 seconds before conducting the next test.

P0441 EVAP CONTROL SYSTEM

[MR18DE]

< DTC/CIRCUIT DIAGNOSIS >

TESTING CONDITION:

Always perform test at a temperature of 5°C (41°F) or more.

>> GO TO 3.

3. PERFORM DTC CONFIRMATION PROCEDURE-I

With CONSULT-III

1. Start engine and warm it up to normal operating temperature.
2. Turn ignition switch OFF and wait at least 10 seconds.
3. Start engine and let it idle for at least 70 seconds.
4. Select "PURG FLOW P0441" of "EVAPORATIVE SYSTEM" in "DTC WORK SUPPORT" mode with CONSULT-III.
5. Touch "START".

Is **COMPLETED** displayed on CONSULT-III screen?

YES >> GO TO 5.

NO >> GO TO 4.

4. PERFORM DTC CONFIRMATION PROCEDURE-II

When the following conditions are met, "TESTING" will be displayed on the CONSULT-III screen. Maintain the conditions continuously until "TESTING" changes to "COMPLETED". (It will take at least 35 seconds.)

Selector lever	Suitable position
VHCL SPEED SE	32 - 120 km/h (20 - 75 mph)
ENG SPEED	500 - 3,800 rpm
B/FUEL SCHDL	1.0 - 10.0 msec
COOLAN TEMP/S	More than 0°C (32°F)

CAUTION:

Always drive vehicle at a safe speed.

If "TESTING" is not changed for a long time, retry from step 2.

Is "COMPLETED" displayed on CONSULT-III screen?

YES >> GO TO 5.

NO >> Perform DTC CONFIRMATION PROCEDURE again. GO TO 3.

5. PERFORM DTC CONFIRMATION PROCEDURE-II

Touch "SELF-DIAG RESULT".

Which is displayed on CONSULT-III screen?

OK >> INSPECTION END

NG >> Go to [EC-240, "Diagnosis Procedure"](#).

6. PERFORM COMPONENT FUNCTION CHECK

Perform component function check. Refer to [EC-239, "Component Function Check"](#).

NOTE:

Use component function check to check the overall monitoring function of the EVAP control system purge flow monitoring. During this check, a 1st trip DTC might not be confirmed.

Is the inspection result normal?

YES >> INSPECTION END

NO >> Go to [EC-240, "Diagnosis Procedure"](#).

Component Function Check

INFOID:000000004833349

1. PERFORM COMPONENT FUNCTION CHECK

Without CONSULT-III

1. Lift up drive wheels.
2. Start engine and warm it up to normal operating temperature.
3. Turn ignition switch OFF and wait at least 10 seconds.
4. Start engine and wait at least 70 seconds.

P0441 EVAP CONTROL SYSTEM

[MR18DE]

< DTC/CIRCUIT DIAGNOSIS >

5. Set voltmeter probes to ECM harness connector and ground.

ECM		Ground
Connector	Terminal	
F8	42 (EVAP control system pressure sensor signal)	Ground

6. Check EVAP control system pressure sensor value at idle speed and note it.
7. Establish and maintain the following conditions for at least 1 minute.

Air conditioner switch	ON
Headlamp switch	ON
Rear window defogger switch	ON
Engine speed	Approx. 3,000 rpm
Selector lever	Any position other than P, N or R

8. Verify that EVAP control system pressure sensor value stays 0.1 V less than the value at idle speed (measured at step 6 for at least 1 second).

Is the inspection result normal?

- YES >> INSPECTION END
NO >> Go to [EC-240, "Diagnosis Procedure"](#).

Diagnosis Procedure

INFOID:000000004833350

1.CHECK EVAP CANISTER

1. Turn ignition switch OFF.
2. Check EVAP canister for cracks.

Is the inspection result normal?

- YES-1 >> With CONSULT-III: GO TO 2.
YES-2 >> Without CONSULT-III: GO TO 3.
NO >> Replace EVAP canister.

2.CHECK PURGE FLOW

With CONSULT-III

1. Disconnect vacuum hose connected to EVAP canister purge volume control solenoid valve at EVAP service port and install vacuum gauge. For the location of EVAP service port, refer to [EC-68, "System Description"](#).
2. Start engine and let it idle.
3. Select "PURG VOL CONT/V" in "ACTIVE TEST" mode with CONSULT-III.
4. Rev engine up to 2,000 rpm.
5. Touch "Qd" and "Qu" on CONSULT-III screen to adjust "PURG VOL C/V" opening and check vacuum existence.

PURG VOL C/V	Vacuum
100%	Existed
0%	Not existed

Is the inspection result normal?

- YES >> GO TO 7.
NO >> GO TO 4.

3.CHECK PURGE FLOW

Without CONSULT-III

1. Start engine and warm it up to normal operating temperature.
2. Stop engine.

P0441 EVAP CONTROL SYSTEM

[MR18DE]

< DTC/CIRCUIT DIAGNOSIS >

3. Disconnect vacuum hose connected to EVAP canister purge volume control solenoid valve at EVAP service port and install vacuum gauge. For the location of EVAP service port, refer to [EC-68, "System Description"](#).
4. Start engine and let it idle.
Do not depress accelerator pedal even slightly.
5. Check vacuum gauge indication before 60 seconds passed after starting engine.

Vacuum should not exist.

6. Revving engine up to 2,000rpm after 100 seconds passed after starting engine.

Vacuum should exist.

Is the inspection result normal?

- YES >> GO TO 7.
- NO >> GO TO 4.

4.CHECK EVAP PURGE LINE

1. Turn ignition switch OFF.
2. Check EVAP purge line for improper connection or disconnection.
Refer to [EC-68, "System Description"](#).

Is the inspection result normal?

- YES >> GO TO 5.
- NO >> Repair it.

5.CHECK EVAP PURGE HOSE AND PURGE PORT

1. Disconnect purge hoses connected to EVAP service port **A** and EVAP canister purge volume control solenoid valve **B**.
2. Blow air into each hose and EVAP purge port **C**.

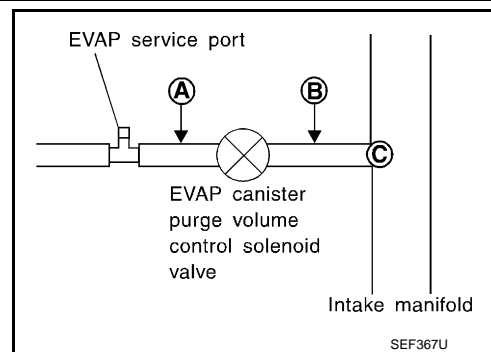

3. Check that air flows freely.

Is the inspection result normal?

- YES-1 >> With CONSULT-III: GO TO 6.
- YES-2 >> Without CONSULT-III: GO TO 7.
- NO >> Repair or clean hoses and/or purge port.

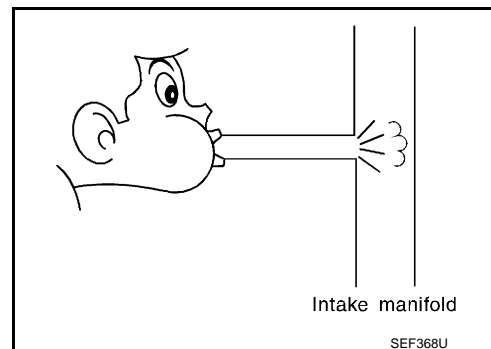

6.CHECK EVAP CANISTER PURGE VOLUME CONTROL SOLENOID VALVE

Ⓜ With CONSULT-III

1. Start engine.
2. Perform "PURG VOL CONT/V" in "ACTIVE TEST" mode with CONSULT-III. Check that engine speed varies according to the valve opening.

Is the inspection result normal?

- YES >> GO TO 8.
- NO >> GO TO 7.

P0441 EVAP CONTROL SYSTEM

[MR18DE]

< DTC/CIRCUIT DIAGNOSIS >

7. CHECK EVAP CANISTER PURGE VOLUME CONTROL SOLENOID VALVE

Refer to [EC-254, "Component Inspection"](#).

Is the inspection result normal?

YES >> GO TO 8.

NO >> Replace EVAP canister purge volume control solenoid valve.

8. CHECK EVAP CONTROL SYSTEM PRESSURE SENSOR CONNECTOR

1. Disconnect EVAP control system pressure sensor harness connector.

2. Check connectors for water.

Water should not exist.

Is the inspection result normal?

YES >> GO TO 9.

NO >> Replace EVAP control system pressure sensor.

9. CHECK EVAP CONTROL SYSTEM PRESSURE SENSOR FUNCTION

Refer to [EC-270, "DTC Logic"](#) for DTC P0452, [EC-275, "DTC Logic"](#) for DTC P0453.

Is the inspection result normal?

YES >> GO TO 10.

NO >> Replace EVAP control system pressure sensor.

10. CHECK RUBBER TUBE FOR CLOGGING

1. Disconnect rubber tube connected to EVAP canister vent control valve.

2. Check the rubber tube for clogging.

Is the inspection result normal?

YES >> GO TO 11.

NO >> Clean the rubber tube using an air blower.

11. CHECK DRAIN FILTER

Refer to [EC-243, "Component Inspection \(Drain filter\)"](#).

Is the inspection result normal?

YES >> GO TO 12.

NO >> Replace drain filter.

12. CHECK EVAP CANISTER VENT CONTROL VALVE

Refer to [EC-261, "Component Inspection"](#).

Is the inspection result normal?

YES >> GO TO 13.

NO >> Replace EVAP canister vent control valve.

13. CHECK EVAP PURGE LINE

Inspect EVAP purge line (pipe and rubber tube). Check for evidence of leaks.

Refer to [EC-473, "Inspection"](#).

Is the inspection result normal?

YES >> GO TO 14.

NO >> Replace it.

14. CLEAN EVAP PURGE LINE

Clean EVAP purge line (pipe and rubber tube) using air blower.

>> GO TO 15.

15. CHECK INTERMITTENT INCIDENT

Refer to [GI-34, "Intermittent Incident"](#).

P0441 EVAP CONTROL SYSTEM

< DTC/CIRCUIT DIAGNOSIS >

[MR18DE]

>> INSPECTION END

Component Inspection (Drain filter)

INFOID:000000004833351

1. CHECK DRAIN FILTER

1. Check visually for insect nests in the drain filter air inlet.
2. Check visually for cracks or flaws in the appearance.
3. Check visually for cracks or flaws in the hose.
4. Blow air into port A and check that it flows freely out of port B.
5. Block port B.
6. Blow air into port A and check that there is no leakage.

Is the inspection result normal?

- YES >> INSPECTION END
NO >> Replace drain filter.

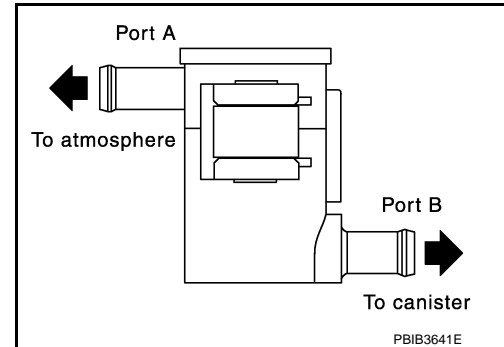

A
EC
C
D
E
F
G
H
I
J
K
L
M
N
O
P

P0442 EVAP CONTROL SYSTEM

< DTC/CIRCUIT DIAGNOSIS >

[MR18DE]

P0442 EVAP CONTROL SYSTEM

DTC Logic

INFOID:000000004833352

DTC DETECTION LOGIC

NOTE:

If DTC P0442 is displayed with DTC P0456, first perform the trouble diagnosis for DTC P0456. Refer to [EC-287, "DTC Logic"](#).

This diagnosis detects leaks in the EVAP purge line using engine intake manifold vacuum.

If pressure does not increase, the ECM will check for leaks in the line between the fuel tank and EVAP canister purge volume control solenoid valve, under the following "Vacuum test" conditions.

The EVAP canister vent control valve is closed to shut the EVAP purge line off. The EVAP canister purge volume control solenoid valve will then be opened to depressurize the EVAP purge line using intake manifold vacuum. After this occurs, the EVAP canister purge volume control solenoid valve will be closed.

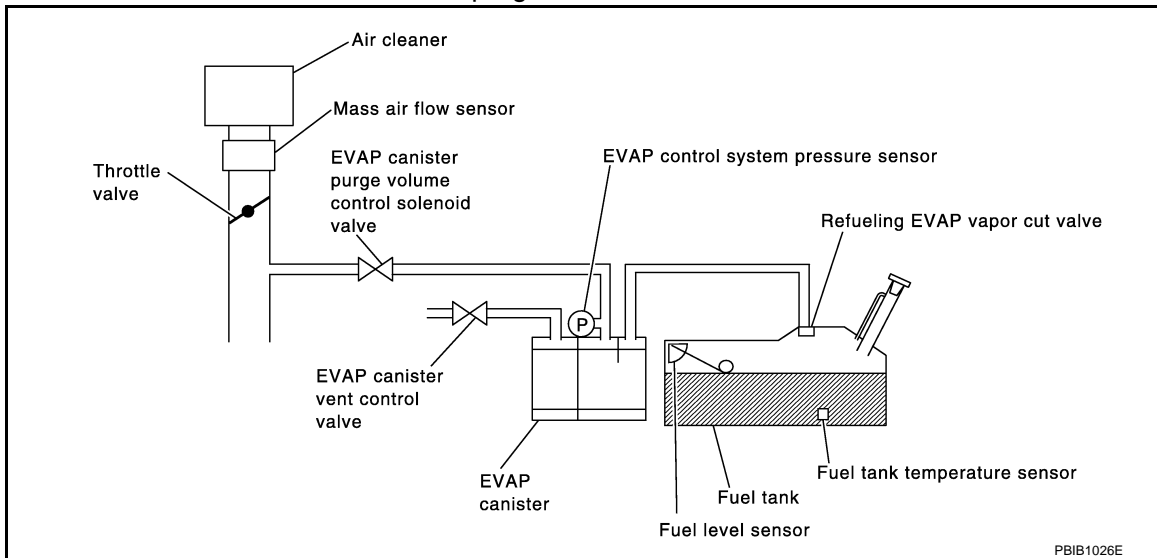

DTC No.	Trouble diagnosis name	DTC detecting condition	Possible cause
P0442	EVAP control system small leak detected (negative pressure)	EVAP control system has a leak, EVAP control system does not operate properly.	<ul style="list-style-type: none"> • Incorrect fuel tank vacuum relief valve • Incorrect fuel filler cap used • Fuel filler cap remains open or fails to close. • Foreign matter caught in fuel filler cap. • Leak is in line between intake manifold and EVAP canister purge volume control solenoid valve. • Foreign matter caught in EVAP canister vent control valve. • EVAP canister or fuel tank leaks • EVAP purge line (pipe and rubber tube) leaks • EVAP purge line rubber tube bent • Loose or disconnected rubber tube • EVAP canister vent control valve and the circuit • EVAP canister purge volume control solenoid valve and the circuit • Fuel tank temperature sensor • O-ring of EVAP canister vent control valve is missing or damaged • EVAP canister is saturated with water • EVAP control system pressure sensor • Fuel level sensor and the circuit • Refueling EVAP vapor cut valve • ORVR system leaks • Drain filter

CAUTION:

• Use only a genuine NISSAN fuel filler cap as a replacement. If an incorrect fuel filler cap is used, the MIL may come on.

P0442 EVAP CONTROL SYSTEM

[MR18DE]

< DTC/CIRCUIT DIAGNOSIS >

- If the fuel filler cap is not tightened properly, the MIL may come on.
- Use only a genuine NISSAN rubber tube as a replacement.

DTC CONFIRMATION PROCEDURE

1. PRECONDITIONING

If DTC Confirmation Procedure has been previously conducted, always turn ignition switch OFF and wait at least 10 seconds before conducting the next test.

TESTING CONDITION:

- Perform "DTC WORK SUPPORT" when the fuel level is between 1/4 and 3/4 full, and vehicle is placed on flat level surface.
- Always perform test at a temperature of 0 to 30°C (32 to 86°F).

NOTE:

Make sure that EVAP hoses are connected to EVAP canister purge volume control solenoid valve properly.

Do you have CONSULT-III?

YES >> GO TO 2.

NO >> GO TO 3.

2. PERFORM DTC CONFIRMATION PROCEDURE

With CONSULT-III

1. Turn ignition switch ON.
2. Turn ignition switch OFF and wait at least 10 seconds.
3. Turn ignition switch ON and select "DATA MONITOR" mode with CONSULT-III.
4. Make sure that the following conditions are met.
COOLAN TEMP/S: 0 - 70°C (32 - 158°F)
INT/A TEMP SE: 0 - 30°C (32 - 86°F)
5. Select "EVAP SML LEAK P0442/P1442" of "EVAPORATIVE SYSTEM" in "DTC WORK SUPPORT" mode with CONSULT-III.
Follow the instruction displayed.

NOTE:

If the engine speed cannot be maintained within the range displayed on the CONSULT-III screen, go to [EC-12, "BASIC INSPECTION : Special Repair Requirement"](#).

Which is displayed on CONSULT-III screen?

OK >> INSPECTION END

NG >> Go to [EC-245, "Diagnosis Procedure"](#).

3. PERFORM COMPONENT FUNCTION CHECK

With GST

NOTE:

Be sure to read the explanation of DRIVING PATTERN in [EC-451, "How to Set SRT Code"](#) before driving vehicle.

1. Start engine.
2. Drive vehicle according to DRIVING PATTERN.
3. Stop vehicle.
4. Turn ignition switch OFF, wait at least 10 seconds and then turn ON.
5. Select Service \$07 with GST.

Is 1st trip DTC displayed?

YES-1 >> P0441: Go to [EC-240, "Diagnosis Procedure"](#).

YES-2 >> P0442: Go to [EC-245, "Diagnosis Procedure"](#).

NO >> INSPECTION END

Diagnosis Procedure

INFOID:000000004833353

1. CHECK FUEL FILLER CAP DESIGN

1. Turn ignition switch OFF.

P0442 EVAP CONTROL SYSTEM

[MR18DE]

< DTC/CIRCUIT DIAGNOSIS >

2. Check for genuine NISSAN fuel filler cap design.

Is the inspection result normal?

YES >> GO TO 2.

NO >> Replace with genuine NISSAN fuel filler cap.

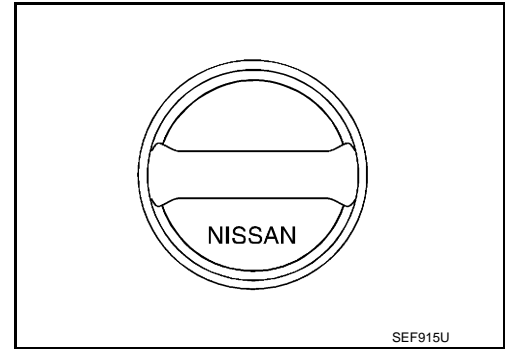

2. CHECK FUEL FILLER CAP INSTALLATION

Check that the cap is tightened properly by rotating the cap clockwise.

Is the inspection result normal?

YES >> GO TO 3.

NO >> Open fuel filler cap, then clean cap and fuel filler neck threads using air blower. Then retighten until ratcheting sound is heard.

3. CHECK FUEL FILLER CAP FUNCTION

Check for air releasing sound while opening the fuel filler cap.

Is the inspection result normal?

YES >> GO TO 5.

NO >> GO TO 4.

4. CHECK FUEL TANK VACUUM RELIEF VALVE

Refer to [EC-249, "Component Inspection \(Fuel filler cap\)"](#).

Is the inspection result normal?

YES >> GO TO 5.

NO >> Replace fuel filler cap with a genuine one.

5. CHECK FOR EVAP LEAK

Refer to [EC-473, "Inspection"](#).

Is there any leak in EVAP line?

YES >> Repair or replace.

NO >> GO TO 6.

6. CHECK DRAIN FILTER

Refer to [EC-249, "Component Inspection \(Drain filter\)"](#).

Is the inspection result normal?

YES >> GO TO 7.

NO >> Replace drain filter.

7. CHECK EVAP CANISTER VENT CONTROL VALVE

Check the following.

- EVAP canister vent control valve is installed properly.

Refer to [EC-475, "Exploded View"](#).

- EVAP canister vent control valve.

Refer to [EC-261, "Component Inspection"](#).

Is the inspection result normal?

YES >> GO TO 8.

NO >> Repair or replace EVAP canister vent control valve and O-ring.

8. CHECK IF EVAP CANISTER IS SATURATED WITH WATER

1. Remove EVAP canister with EVAP canister vent control valve and EVAP control system pressure sensor attached.

P0442 EVAP CONTROL SYSTEM

[MR18DE]

< DTC/CIRCUIT DIAGNOSIS >

2. Does water drain from the EVAP canister?

Does water drain from the EVAP canister?

YES >> GO TO 9.

NO-1 >> With CONSULT-III: GO TO 11.

NO-2 >> Without CONSULT-III: GO TO 12.

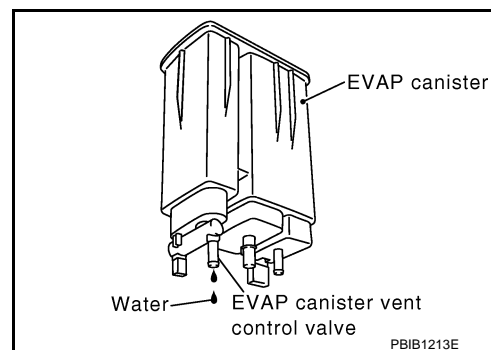

9. CHECK EVAP CANISTER

Weigh the EVAP canister with the EVAP canister vent control valve and EVAP control system pressure sensor attached.

The weight should be less than 1.9 kg (4.2 lb).

Is the inspection result normal?

YES-1 >> With CONSULT-III: GO TO 11.

YES-2 >> Without CONSULT-III: GO TO 12.

NO >> GO TO 10.

10. DETECT MALFUNCTIONING PART

Check the following.

- EVAP canister for damage
- EVAP hose between EVAP canister and vehicle frame for clogging or poor connection

>> Repair hose or replace EVAP canister.

11. CHECK EVAP CANISTER PURGE VOLUME CONTROL SOLENOID VALVE OPERATION

With CONSULT-III

1. Disconnect vacuum hose to EVAP canister purge volume control solenoid valve at EVAP service port.
2. Start engine.
3. Perform "PURG VOL CONT/V" in "ACTIVE TEST" mode.
4. Touch "Qu" on CONSULT-III screen to increase "PURG VOL C/V" opening to 100%.
5. Check vacuum hose for vacuum.

Vacuum should exist.

Is the inspection result normal?

YES >> GO TO 14.

NO >> GO TO 13.

12. CHECK EVAP CANISTER PURGE VOLUME CONTROL SOLENOID VALVE OPERATION

Without CONSULT-III

1. Start engine and warm it up to normal operating temperature.
2. Stop engine.
3. Disconnect vacuum hose to EVAP canister purge volume control solenoid valve at EVAP service port.
4. Start engine and let it idle for at least 80 seconds.
5. Check vacuum hose for vacuum when revving engine up to 2,000 rpm.

Vacuum should exist.

Is the inspection result normal?

YES >> GO TO 14.

NO >> GO TO 13.

13. CHECK VACUUM HOSE

Check vacuum hoses for clogging or disconnection. Refer to [EC-68. "System Description"](#).

Is the inspection result normal?

P0442 EVAP CONTROL SYSTEM

[MR18DE]

< DTC/CIRCUIT DIAGNOSIS >

- YES >> GO TO 14.
NO >> Repair or reconnect the hose.

14.CHECK EVAP CANISTER PURGE VOLUME CONTROL SOLENOID VALVE

Refer to [EC-254, "Component Inspection"](#).

Is the inspection result normal?

- YES >> GO TO 15.
NO >> Replace EVAP canister purge volume control solenoid valve.

15.CHECK FUEL TANK TEMPERATURE SENSOR

Refer to [EC-210, "Component Inspection"](#).

Is the inspection result normal?

- YES >> GO TO 16.
NO >> Replace fuel level sensor unit.

16.CHECK EVAP CONTROL SYSTEM PRESSURE SENSOR

Refer to [EC-267, "DTC Logic"](#).

Is the inspection result normal?

- YES >> GO TO 17.
NO >> Replace EVAP control system pressure sensor.

17.CHECK EVAP PURGE LINE

Check EVAP purge line (pipe, rubber tube, fuel tank and EVAP canister) for cracks or improper connection.

Refer to [EC-68, "System Description"](#).

Is the inspection result normal?

- YES >> GO TO 18.
NO >> Repair or reconnect the hose.

18.CLEAN EVAP PURGE LINE

Clean EVAP purge line (pipe and rubber tube) using air blower.

>> GO TO 19.

19.CHECK EVAP/ORVR LINE

Check EVAP/ORVR line between EVAP canister and fuel tank for clogging, kink, looseness and improper connection. For location, refer to [EC-407, "Description"](#).

Is the inspection result normal?

- YES >> GO TO 20.
NO >> Repair or replace hoses and tubes.

20.CHECK RECIRCULATION LINE

Check recirculation line between fuel filler tube and fuel tank for clogging, kink, cracks, looseness and improper connection.

Is the inspection result normal?

- YES >> GO TO 21.
NO >> Repair or replace hose, tube or fuel filler tube.

21.CHECK REFUELING EVAP VAPOR CUT VALVE

Refer to [EC-410, "Component Inspection \(Refueling EVAP vapor cut valve\)"](#).

Is the inspection result normal?

- YES >> GO TO 22.
NO >> Replace refueling EVAP vapor cut valve with fuel tank.

22.CHECK FUEL LEVEL SENSOR

Refer to [MWI-42, "Component Function Check"](#).

Is the inspection result normal?

- YES >> GO TO 23.

P0442 EVAP CONTROL SYSTEM

[MR18DE]

< DTC/CIRCUIT DIAGNOSIS >

NO >> Replace fuel level sensor unit.

23.CHECK INTERMITTENT INCIDENT

Refer to [GI-34, "Intermittent Incident"](#).

>> INSPECTION END

Component Inspection (Fuel filler cap)

INFOID:000000004833354

1.CHECK FUEL FILLER CAP

1. Turn ignition switch OFF.
2. Remove fuel filler cap.
3. Wipe clean valve housing.

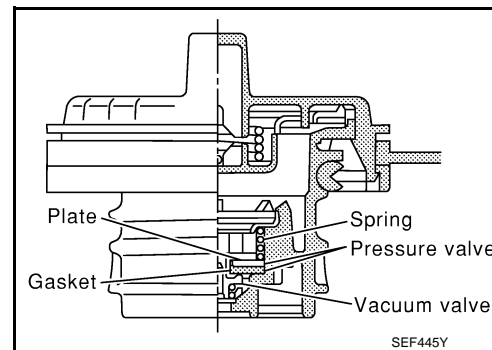

4. Install fuel filler cap adapter (commercial service tool) to fuel filler cap.
5. Check valve opening pressure and vacuum.

Pressure: 15.3 - 20.0 kPa (0.156 - 0.204 kg/cm², 2.22 - 2.90 psi)

Vacuum: -6.0 to -3.3 kPa (-0.061 to -0.034 kg/cm², -0.87 to -0.48 psi)

Is the inspection result normal?

YES >> INSPECTION END

NO >> GO TO 2.

2.REPLACE FUEL FILLER CAP

Replace fuel filler cap.

CAUTION:

Use only a genuine fuel filler cap as a replacement. If an incorrect fuel filler cap is used, the MIL may illuminate.

>> INSPECTION END

Component Inspection (Drain filter)

INFOID:000000004833355

1.CHECK DRAIN FILTER

1. Check visually for insect nests in the drain filter air inlet.
2. Check visually for cracks or flaws in the appearance.
3. Check visually for cracks or flaws in the hose.

P0442 EVAP CONTROL SYSTEM

[MR18DE]

< DTC/CIRCUIT DIAGNOSIS >

4. Blow air into port A and check that it flows freely out of port B.
5. Block port B.
6. Blow air into port A and check that there is no leakage.

Is the inspection result normal?

- YES >> INSPECTION END
NO >> Replace drain filter.

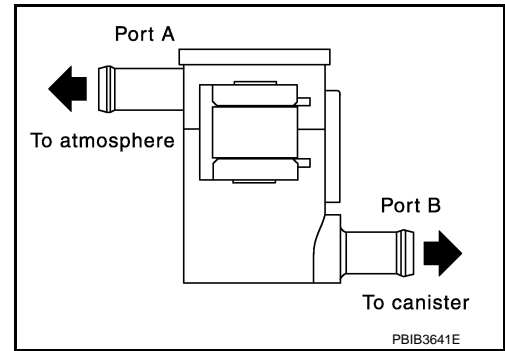

P0443 EVAP CANISTER PURGE VOLUME CONTROL SOLENOID VALVE

< DTC/CIRCUIT DIAGNOSIS >

[MR18DE]

P0443 EVAP CANISTER PURGE VOLUME CONTROL SOLENOID VALVE

Description

INFOID:000000004833356

The EVAP canister purge volume control solenoid valve is used to control the flow rate of fuel vapor from the EVAP canister. The EVAP canister purge volume control solenoid valve is moved by ON/OFF pulses from the ECM. The longer the ON pulse, the greater the amount of fuel vapor that will flow through the valve.

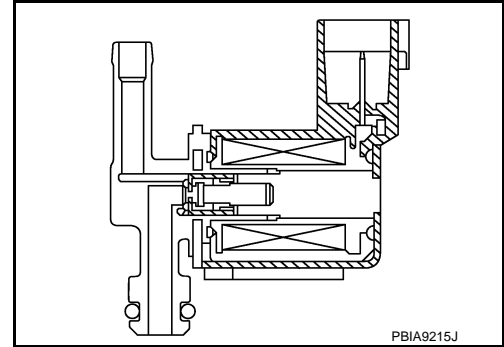

DTC Logic

INFOID:000000004833357

DTC DETECTION LOGIC

DTC No.	Trouble diagnosis name	DTC detecting condition		Possible cause
P0443	EVAP canister purge volume control solenoid valve	A	The canister purge flow is detected during the vehicle is stopped while the engine is running, even when EVAP canister purge volume control solenoid valve is completely closed.	<ul style="list-style-type: none"> • EVAP control system pressure sensor • EVAP canister purge volume control solenoid valve (The valve is stuck open.) • EVAP canister vent control valve • EVAP canister • Hoses (Hoses are connected incorrectly or clogged.)
		B	The canister purge flow is detected during the specified driving conditions, even when EVAP canister purge volume control solenoid valve is completely closed.	

DTC CONFIRMATION PROCEDURE

1. PRECONDITIONING

If DTC Confirmation Procedure has been previously conducted, always turn ignition switch OFF and wait at least 10 seconds before conducting the next test.

TESTING CONDITION:

- Perform DTC CONFIRMATION PROCEDURE when the fuel is between 1/4 and 3/4 full, and vehicle is placed on flat level surface.
- Always perform test at a temperature of 5 to 60°C (41 to 140°F).
- Cool the vehicle so that engine coolant temperature becomes same level as ambient temperature.

Do you have CONSULT-III

- YES >> GO TO 2.
NO >> GO TO 4.

2. PERFORM DTC CONFIRMATION PROCEDURE A

Ⓜ With CONSULT-III

1. Turn ignition switch ON.
2. Select "DATA MONITOR" mode with CONSULT-III.
3. Check that the following condition are met.
FUEL T/TMP SE: 0 - 35°C (32 - 95°F)
4. Start engine and wait at least 60 seconds.
5. Check 1st trip DTC.

Is 1st trip DTC detected?

- YES >> Go to [EC-252, "Diagnosis Procedure"](#).
NO >> GO TO 3.

3. PERFORM DTC CONFIRMATION PROCEDURE B

Ⓜ With CONSULT-III

P0443 EVAP CANISTER PURGE VOLUME CONTROL SOLENOID VALVE

[MR18DE]

< DTC/CIRCUIT DIAGNOSIS >

1. Start engine and warm it up to normal operating temperature.
2. Turn ignition switch OFF and wait at least 10 seconds.
3. Turn ignition switch ON.
4. Select "PURG VOL CN/V P1444" of "EVAPORATIVE SYSTEM" in "DTC WORK SUPPORT" mode with CONSULT-III.
5. Touch "START".
6. Start engine and let it idle until "TESTING" on CONSULT-III changes to "COMPLETED". (It will take approximately 10 seconds.)
If "TESTING" is not displayed after 5 minutes, retry from step 2.
7. Touch "SELF-DIAG RESULT".

Which is displayed on CONSULT-III?

- OK >> INSPECTION END
NG >> Go to [EC-252, "Diagnosis Procedure"](#).

4.PERFORM DTC CONFIRMATION PROCEDURE A

With GST

1. Turn ignition switch ON.
2. Check the voltage between ECM harness connector and ground.

ECM		Ground	Voltage (V)
Connector	Terminal		
F8	43 (Fuel tank temperature sensor signal)	Ground	3.1 - 4.0

3. Start engine and wait at least 60 seconds.
4. Check 1st trip DTC.

Is 1st trip DTC detected?

- YES >> Go to [EC-252, "Diagnosis Procedure"](#).
NO >> GO TO 5.

5.PERFORM DTC CONFIRMATION PROCEDURE

With GST

1. Start engine and warm it up to normal operating temperature.
2. Turn ignition switch OFF and wait at least 10 seconds.
3. Start engine and let it idle for at least 20 seconds.
4. Check 1st trip DTC.

Is 1st trip DTC detected?

- YES >> Go to [EC-252, "Diagnosis Procedure"](#).
NO >> INSPECTION END

Diagnosis Procedure

INFOID:000000004833359

1.CHECK EVAP CANISTER PURGE VOLUME CONTROL SOLENOID VALVE POWER SUPPLY CIRCUIT

1. Turn ignition switch OFF.
2. Disconnect EVAP canister purge volume control solenoid valve harness connector.
3. Turn ignition switch ON.
4. Check the voltage between EVAP canister purge volume control solenoid valve harness connector and ground.

EVAP canister purge volume control solenoid valve		Ground	Voltage
Connector	Terminal		
F32	1	Ground	Battery voltage

Is the inspection result normal?

- YES >> GO TO 3.
NO >> GO TO 2.

P0443 EVAP CANISTER PURGE VOLUME CONTROL SOLENOID VALVE

< DTC/CIRCUIT DIAGNOSIS >

[MR18DE]

2. DETECT MALFUNCTIONING PART

Check the following.

- Harness connectors E8, F1
- IPDM E/R harness connector E14
- Harness for open or short between EVAP canister purge volume control solenoid valve and IPDM E/R
- Harness for open or short between EVAP canister purge volume control solenoid valve and ECM

>> Repair open circuit or short to ground or short to power in harness or connectors.

3. CHECK EVAP CANISTER PURGE VOLUME CONTROL SOLENOID VALVE OUTPUT SIGNAL CIRCUIT FOR OPEN AND SHORT

1. Turn ignition switch OFF.
2. Disconnect ECM harness connector.
3. Check the continuity between EVAP canister purge volume control solenoid valve harness connector and ECM harness connector.

EVAP canister purge volume control solenoid valve		ECM		Continuity
Connector	Terminal	Connector	Terminal	
F32	2	F7	9	Existed

4. Also check harness for short to ground and short to power.

Is the inspection result normal?

YES >> GO TO 4.

NO >> Repair open circuit or short to ground or short to power in harness or connectors.

4. CHECK EVAP CONTROL SYSTEM PRESSURE SENSOR CONNECTOR

1. Disconnect EVAP control system pressure sensor harness connector.
2. Check connectors for water.

Water should not exist.

Is the inspection result normal?

YES >> GO TO 5.

NO >> Replace EVAP control system pressure sensor.

5. CHECK EVAP CONTROL SYSTEM PRESSURE SENSOR

Refer to [EC-269, "Component Inspection"](#).

Is the inspection result normal?

YES-1 >> With CONSULT-III: GO TO 6.

YES-2 >> Without CONSULT-III: GO TO 7.

NO >> Replace EVAP control system pressure sensor.

6. CHECK EVAP CANISTER PURGE VOLUME CONTROL SOLENOID VALVE

Ⓜ With CONSULT-III

1. Turn ignition switch OFF.
2. Reconnect harness connectors disconnected.
3. Start engine.
4. Perform "PURG VOL CONT/V" in "ACTIVE TEST" mode with CONSULT-III. Check that engine speed varies according to the valve opening.

Is the inspection result normal?

YES >> GO TO 8.

NO >> GO TO 7.

7. CHECK EVAP CANISTER PURGE VOLUME CONTROL SOLENOID VALVE

Refer to [EC-254, "Component Inspection"](#).

Is the inspection result normal?

P0443 EVAP CANISTER PURGE VOLUME CONTROL SOLENOID VALVE

[MR18DE]

< DTC/CIRCUIT DIAGNOSIS >

- YES >> GO TO 8.
NO >> Replace EVAP canister purge volume control solenoid valve.

8. CHECK RUBBER TUBE FOR CLOGGING

1. Disconnect rubber tube connected to EVAP canister vent control valve.
2. Check the rubber tube for clogging.

Is the inspection result normal?

- YES >> GO TO 9.
NO >> Clean the rubber tube using an air blower.

9. CHECK EVAP CANISTER VENT CONTROL VALVE

Refer to [EC-261, "Component Inspection"](#).

Is the inspection result normal?

- YES >> GO TO 10.
NO >> Replace EVAP canister vent control valve.

10. CHECK IF EVAP CANISTER IS SATURATED WITH WATER

1. Remove EVAP canister with EVAP canister vent control valve and EVAP control system pressure sensor attached.
2. Check if water will drain from EVAP canister.

Does water drain from the EVAP canister?

- YES >> GO TO 11.
NO >> GO TO 13.

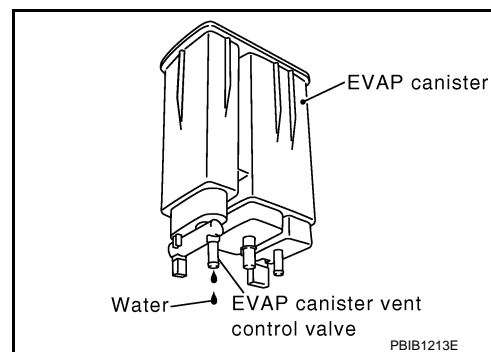

11. CHECK EVAP CANISTER

Weigh the EVAP canister with the EVAP canister vent control valve and EVAP control system pressure sensor attached.

The weight should be less than 1.9 kg (4.2 lb).

Is the inspection result normal?

- YES >> GO TO 13.
NO >> GO TO 12.

12. DETECT MALFUNCTIONING PART

Check the following.

- EVAP canister for damage
- EVAP hose between EVAP canister and vehicle frame for clogging or poor connection

>> Repair hose or replace EVAP canister.

13. CHECK INTERMITTENT INCIDENT

Refer to [GI-34, "Intermittent Incident"](#).

>> INSPECTION END

Component Inspection

INFOID:000000004833360

1. CHECK EVAP CANISTER PURGE VOLUME CONTROL SOLENOID VALVE

ⓑ **With CONSULT-III**

1. Turn ignition switch OFF.
2. Reconnect all harness connectors disconnected.
3. Disconnect EVAP purge hoses connected to EVAP canister purge volume control solenoid valve.

P0443 EVAP CANISTER PURGE VOLUME CONTROL SOLENOID VALVE

[MR18DE]

< DTC/CIRCUIT DIAGNOSIS >

4. Turn ignition switch ON.
5. Select "PURG VOL CONT/V" in "ACTIVE TEST" mode with CONSULT-III.
6. Touch "Qd" and "Qu" on CONSULT-III screen to adjust "PURG VOL C/V" opening and check air passage continuity of EVAP canister purge volume control solenoid valve under the following conditions.

Condition (PURG VOL C/V value)	Air passage continuity between (A) and (B)
100%	Existed
0%	Not existed

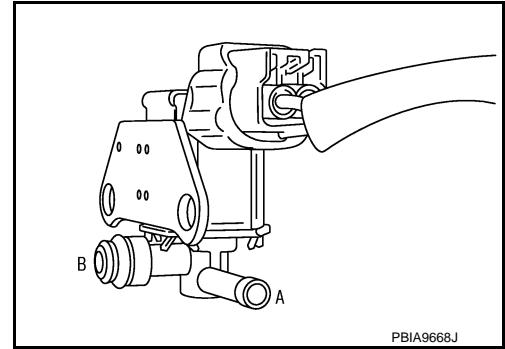

⊗ Without CONSULT-III

1. Turn ignition switch OFF.
2. Disconnect EVAP canister purge volume control solenoid valve harness connector.
3. Disconnect EVAP purge hoses connected to EVAP canister purge volume control solenoid valve.
4. Check air passage continuity of EVAP canister purge volume control solenoid valve under the following conditions.

Condition	Air passage continuity between (A) and (B)
12 V direct current supply between terminals 1 and 2	Existed
No supply	Not existed

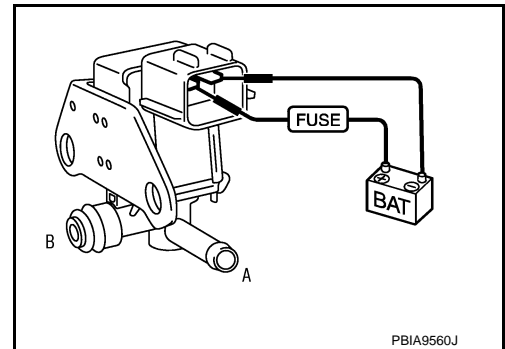

Is the inspection result normal?

- YES >> INSPECTION END
 NO >> Replace EVAP canister purge volume control solenoid valve

A
EC
C
D
E
F
G
H
I
J
K
L
M
N
O
P

P0444, P0445 EVAP CANISTER PURGE VOLUME CONTROL SOLENOID VALVE

< DTC/CIRCUIT DIAGNOSIS >

[MR18DE]

P0444, P0445 EVAP CANISTER PURGE VOLUME CONTROL SOLENOID VALVE

Description

INFOID:000000004833361

The EVAP canister purge volume control solenoid valve is used to control the flow rate of fuel vapor from the EVAP canister. The EVAP canister purge volume control solenoid valve is moved by ON/OFF pulses from the ECM. The longer the ON pulse, the greater the amount of fuel vapor that will flow through the valve.

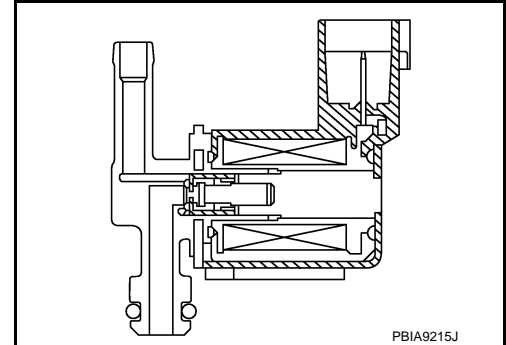

DTC Logic

INFOID:000000004833362

DTC DETECTION LOGIC

DTC No.	Trouble diagnosis name	DTC detecting condition	Possible cause
P0444	EVAP canister purge volume control solenoid valve circuit open	An excessively low voltage signal is sent to ECM through the valve	<ul style="list-style-type: none">• Harness or connectors (The solenoid valve circuit is open or shorted.)• EVAP canister purge volume control solenoid valve
P0445	EVAP canister purge volume control solenoid valve circuit shorted	An excessively high voltage signal is sent to ECM through the valve	<ul style="list-style-type: none">• Harness or connectors (The solenoid valve circuit is shorted.)• EVAP canister purge volume control solenoid valve

DTC CONFIRMATION PROCEDURE

1. CONDITIONING

If DTC Confirmation Procedure has been previously conducted, always turn ignition switch OFF and wait at least 10 seconds before conducting the next test.

TESTING CONDITION:

Before performing the following procedure, confirm battery voltage is more than 11 V at idle.

>> GO TO 2.

2. PERFORM DTC CONFIRMATION PROCEDURE

1. Start engine and let it idle for at least 13 seconds.
2. Check 1st trip DTC.

Is 1st trip DTC detected?

- YES >> Go to [EC-256, "Diagnosis Procedure"](#).
NO >> INSPECTION END

Diagnosis Procedure

INFOID:000000004833364

1. CHECK EVAP CANISTER PURGE VOLUME CONTROL SOLENOID VALVE POWER SUPPLY CIRCUIT

1. Turn ignition switch OFF.
2. Disconnect EVAP canister purge volume control solenoid valve harness connector.
3. Turn ignition switch ON.
4. Check the voltage between EVAP canister purge volume control solenoid valve harness connector and ground.

P0444, P0445 EVAP CANISTER PURGE VOLUME CONTROL SOLENOID VALVE

< DTC/CIRCUIT DIAGNOSIS >

[MR18DE]

EVAP canister purge volume control solenoid valve		Ground	Voltage
Connector	Terminal		
F32	1	Ground	Battery voltage

A

EC

Is the inspection result normal?

YES >> GO TO 3.

NO >> GO TO 2.

C

2. DETECT MALFUNCTIONING PART

Check the following.

- IPDM E/R harness connector E14
- Harness connectors E8, F1
- Harness for open or short between EVAP canister purge volume control solenoid valve and IPDM E/R
- Harness for open or short between EVAP canister purge volume control solenoid valve and ECM

D

E

>> Repair open circuit or short to ground or short to power in harness or connectors.

F

3. CHECK EVAP CANISTER PURGE VOLUME CONTROL SOLENOID VALVE OUTPUT SIGNAL CIRCUIT FOR OPEN AND SHORT

1. Turn ignition switch OFF.
2. Disconnect ECM harness connector.
3. Check the continuity between EVAP canister purge volume control solenoid valve harness connector and ECM harness connector.

G

H

EVAP canister purge volume control solenoid valve		ECM		Continuity
Connector	Terminal	Connector	Terminal	
F32	2	F7	9	Existed

I

J

4. Also check harness for short to ground and short to power.

Is the inspection result normal?

YES-1 >> With CONSULT-III: GO TO 4.

YES-2 >> Without CONSULT-III: GO TO 5.

NO >> Repair open circuit or short to ground or short to power in harness or connectors.

K

4. CHECK EVAP CANISTER PURGE VOLUME CONTROL SOLENOID VALVE OPERATION

L

 With CONSULT-III

1. Reconnect all harness connectors disconnected.
2. Start engine.
3. Perform "PURG VOL CONT/V" in "ACTIVE TEST" mode with CONSULT-III. Check that engine speed varies according to the valve opening.

M

Is the inspection result normal?

YES >> GO TO 6.

NO >> GO TO 5.

N

5. CHECK EVAP CANISTER PURGE VOLUME CONTROL SOLENOID VALVE

O

Refer to [EC-258, "Component Inspection"](#).

Is the inspection result normal?

YES >> GO TO 6.

NO >> Replace EVAP canister purge volume control solenoid valve.

P

6. CHECK INTERMITTENT INCIDENT

Refer to [GI-34, "Intermittent Incident"](#).

>> INSPECTION END

P0444, P0445 EVAP CANISTER PURGE VOLUME CONTROL SOLENOID VALVE

< DTC/CIRCUIT DIAGNOSIS >

[MR18DE]

Component Inspection

INFOID:000000004833365

1. CHECK EVAP CANISTER PURGE VOLUME CONTROL SOLENOID VALVE

④ With CONSULT-III

1. Turn ignition switch OFF.
2. Reconnect all harness connectors disconnected.
3. Disconnect EVAP purge hoses connected to EVAP canister purge volume control solenoid valve.
4. Turn ignition switch ON.
5. Select "PURG VOL CONT/V" in "ACTIVE TEST" mode with CONSULT-III.
6. Touch "Qd" and "Qu" on CONSULT-III screen to adjust "PURG VOL C/V" opening and check air passage continuity of EVAP canister purge volume control solenoid valve under the following conditions.

Condition (PURG VOL C/V value)	Air passage continuity between (A) and (B)
100%	Existed
0%	Not existed

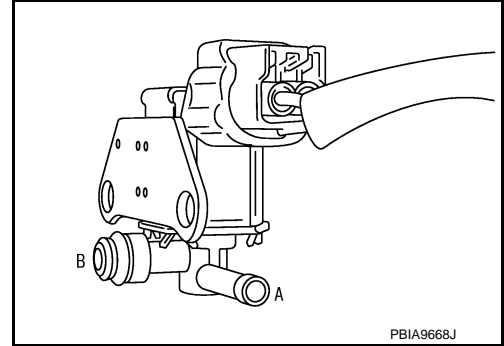

⊗ Without CONSULT-III

1. Turn ignition switch OFF.
2. Disconnect EVAP canister purge volume control solenoid valve harness connector.
3. Disconnect EVAP purge hoses connected to EVAP canister purge volume control solenoid valve.
4. Check air passage continuity of EVAP canister purge volume control solenoid valve under the following conditions.

Condition	Air passage continuity between (A) and (B)
12 V direct current supply between terminals 1 and 2	Existed
No supply	Not existed

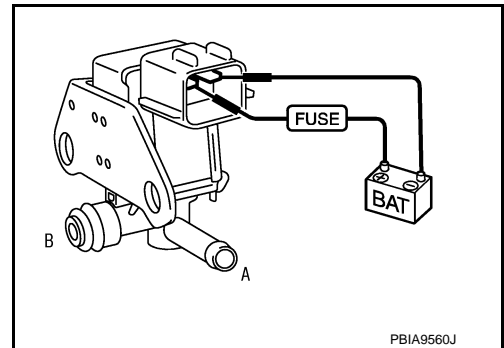

Is the inspection result normal?

YES >> INSPECTION END

NO >> Replace EVAP canister purge volume control solenoid valve

P0447 EVAP CANISTER VENT CONTROL VALVE

< DTC/CIRCUIT DIAGNOSIS >

[MR18DE]

P0447 EVAP CANISTER VENT CONTROL VALVE

Description

INFOID:000000004833366

The EVAP canister vent control valve is located on the EVAP canister and is used to seal the canister vent.

This solenoid valve responds to signals from the ECM. When the ECM sends an ON signal, the coil in the solenoid valve is energized. A plunger will then move to seal the canister vent. The ability to seal the vent is necessary for the on board diagnosis of other evaporative emission control system components.

This solenoid valve is used only for diagnosis, and usually remains opened.

When the vent is closed, under normal purge conditions, the evaporative emission control system is depressurized and allows "EVAP Control System" diagnosis.

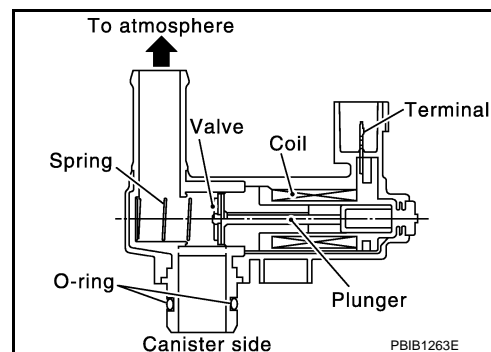

DTC Logic

INFOID:000000004833367

DTC DETECTION LOGIC

DTC No.	Trouble diagnosis name	DTC detecting condition	Possible cause
P0447	EVAP canister vent control valve circuit open	An improper voltage signal is sent to ECM through EVAP canister vent control valve.	<ul style="list-style-type: none">• Harness or connectors (The valve circuit is open or shorted.)• EVAP canister vent control valve

DTC CONFIRMATION PROCEDURE

1. PRECONDITIONING

If DTC Confirmation Procedure has been previously conducted, always turn ignition switch OFF and wait at least 10 seconds before conducting the next test.

TESTING CONDITION:

Before performing the following procedure, confirm battery voltage is more than 11 V at idle.

>> GO TO 2.

2. PERFORM DTC CONFIRMATION PROCEDURE

1. Start engine and wait at least 8 seconds.
2. Check 1st trip DTC.

Is 1st trip DTC detected?

- YES >> Go to [EC-259, "Diagnosis Procedure"](#).
NO >> INSPECTION END

Diagnosis Procedure

INFOID:000000004833369

1. INSPECTION START

Do you have CONSULT-III?

Do you have CONSULT-III?

- YES >> GO TO 2.
NO >> GO TO 3.

2. CHECK EVAP CANISTER VENT CONTROL VALVE CIRCUIT

With CONSULT-III

1. Turn ignition switch OFF and then turn ON.
2. Select "VENT CONTROL/V" in "ACTIVE TEST" mode with CONSULT-III.
3. Touch "ON/OFF" on CONSULT-III screen.
4. Check for operating sound of the valve.

P0447 EVAP CANISTER VENT CONTROL VALVE

< DTC/CIRCUIT DIAGNOSIS >

[MR18DE]

Clicking sound should be heard.

Is the inspection result normal?

- YES >> GO TO 7.
- NO >> GO TO 3.

3.CHECK EVAP CANISTER VENT CONTROL VALVE POWER SUPPLY CIRCUIT

1. Turn ignition switch OFF.
2. Disconnect EVAP canister vent control valve harness connector.
3. Turn ignition switch ON.
4. Check the voltage between EVAP canister vent control valve harness connector and ground.

EVAP canister vent control valve		Ground	Voltage
Connector	Terminal		
B20	1	Ground	Battery voltage

Is the inspection result normal?

- YES >> GO TO 5.
- NO >> GO TO 4.

4.DETECT MALFUNCTIONING PART

Check the following.

- Harness connectors E8, F1
- Harness connectors E105, M77
- Harness connectors M79, B4
- Harness for open or short between EVAP canister vent control valve and IPDM E/R

>> Repair open circuit or short to ground or short to power in harness or connectors.

5.CHECK EVAP CANISTER VENT CONTROL VALVE OUTPUT SIGNAL CIRCUIT FOR OPEN AND SHORT

1. Turn ignition switch OFF.
2. Disconnect ECM harness connector.
3. Check the continuity between EVAP canister vent control valve harness connector and ECM harness connector.

EVAP canister vent control valve		ECM		Continuity
Connector	Terminal	Connector	Terminal	
B20	2	F7	28	Existed

4. Also check harness for short to ground and short to power.

Is the inspection result normal?

- YES >> GO TO 7.
- NO >> GO TO 6.

6.DETECT MALFUNCTIONING PART

Check the following.

- Junction block connector E8, F1
- Harness connectors E105, M77
- Harness connectors M79, B4
- Harness for open or short between EVAP canister vent control valve and ECM

>> Repair open circuit or short to ground or short to power in harness or connectors.

7.CHECK RUBBER TUBE FOR CLOGGING

1. Disconnect rubber tube connected to EVAP canister vent control valve.
2. Check the rubber tube for clogging.

Is the inspection result normal?

P0447 EVAP CANISTER VENT CONTROL VALVE

[MR18DE]

< DTC/CIRCUIT DIAGNOSIS >

- YES >> GO TO 8.
- NO >> Clean the rubber tube using an air blower.

8.CHECK EVAP CANISTER VENT CONTROL VALVE

Refer to [EC-261. "Component Inspection"](#).

Is the inspection result normal?

- YES >> GO TO 9.
- NO >> Replace EVAP canister vent control valve.

9.CHECK INTERMITTENT INCIDENT

Refer to [GI-34. "Intermittent Incident"](#).

>> INSPECTION END

Component Inspection

INFOID:000000004833370

1.CHECK EVAP CANISTER VENT CONTROL VALVE-I

1. Turn ignition switch OFF.
2. Remove EVAP canister vent control valve from EVAP canister.
3. Check portion (A) of EVAP canister vent control valve for being rusted.

Is it rusted?

- YES >> Replace EVAP canister vent control valve.
- NO >> GO TO 2.

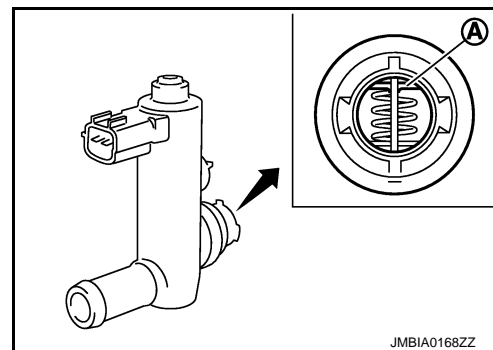

2.CHECK EVAP CANISTER VENT CONTROL VALVE-II

With CONSULT-III

1. Reconnect harness connectors disconnected.
2. Turn ignition switch ON.
3. Perform "VENT CONTROL/V" in "ACTIVE TEST" mode.
4. Check air passage continuity and operation delay time.
Make sure new O-ring is installed properly.

VENT CONT/V condition	Air passage continuity between (A) and (B)
ON	Not existed
OFF	Existed

Operation takes less than 1 second.

Without CONSULT-III

Check air passage continuity and operation delay time under the following conditions.

Make sure new O-ring is installed properly.

Condition	Air passage continuity between (A) and (B)
12 V direct current supply between terminals (1) and (2)	Not existed
OFF	Existed

Operation takes less than 1 second.

Is the inspection result normal?

- YES >> GO TO 3.
- NO >> Replace EVAP canister vent control valve.

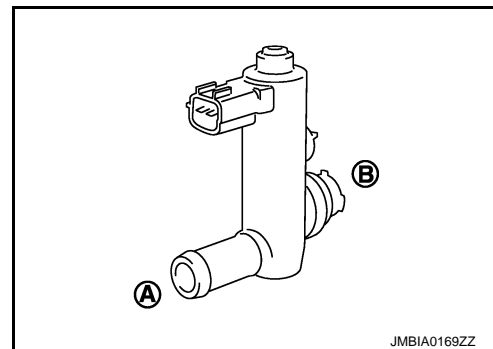

P0447 EVAP CANISTER VENT CONTROL VALVE

< DTC/CIRCUIT DIAGNOSIS >

[MR18DE]

3. CHECK EVAP CANISTER VENT CONTROL VALVE-III

④ With CONSULT-III

1. Clean the air passage [portion (A) to (B)] of EVAP canister vent control valve using an air blower.
2. Perform "VENT CONTROL/V" in "ACTIVE TEST" mode.
3. Check air passage continuity and operation delay time.
Make sure new O-ring is installed properly.

VENT CONT/V condition	Air passage continuity between (A) and (B)
ON	Not existed
OFF	Existed

Operation takes less than 1 second.

⊗ Without CONSULT-III

1. Clean the air passage [portion (A) to (B)] of EVAP canister vent control valve using an air blower.
2. Check air passage continuity and operation delay time under the following conditions.
Make sure new O-ring is installed properly.

Condition	Air passage continuity between (A) and (B)
12 V direct current supply between terminals (1) and (2)	Not existed
OFF	Existed

Operation takes less than 1 second.

Is the inspection result normal?

- YES >> INSPECTION END
NO >> Replace EVAP canister vent control valve.

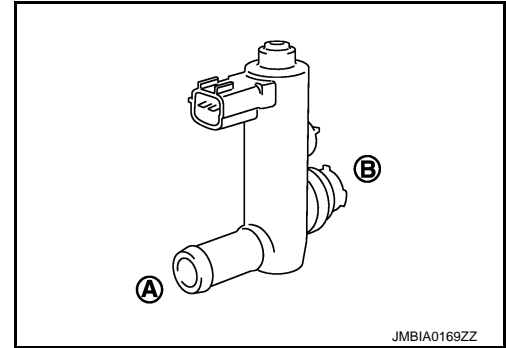

P0448 EVAP CANISTER VENT CONTROL VALVE

< DTC/CIRCUIT DIAGNOSIS >

[MR18DE]

P0448 EVAP CANISTER VENT CONTROL VALVE

Description

INFOID:000000004833371

The EVAP canister vent control valve is located on the EVAP canister and is used to seal the canister vent.

This solenoid valve responds to signals from the ECM. When the ECM sends an ON signal, the coil in the solenoid valve is energized. A plunger will then move to seal the canister vent. The ability to seal the vent is necessary for the on board diagnosis of other evaporative emission control system components.

This solenoid valve is used only for diagnosis, and usually remains opened.

When the vent is closed, under normal purge conditions, the evaporative emission control system is depressurized and allows "EVAP Control System" diagnosis.

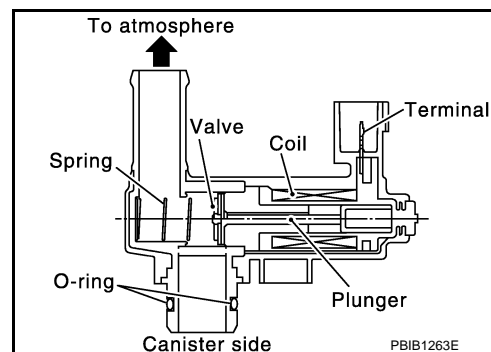

DTC Logic

INFOID:000000004833372

DTC DETECTION LOGIC

DTC No.	Trouble diagnosis name	DTC detecting condition	Possible cause
P0448	EVAP canister vent control valve close	EVAP canister vent control valve remains closed under specified driving conditions.	<ul style="list-style-type: none"> • EVAP canister vent control valve • EVAP control system pressure sensor and the circuit • Blocked rubber tube to EVAP canister vent control valve • EVAP canister is saturated with water

DTC CONFIRMATION PROCEDURE

1. PRECONDITIONING

If DTC Confirmation Procedure has been previously conducted, always turn ignition switch OFF and wait at least 10 seconds before conducting the next test.

>> GO TO 2.

2. PERFORM DTC CONFIRMATION PROCEDURE

④ With CONSULT-III

1. Turn ignition switch ON and wait at least 5 seconds.
2. Turn ignition switch OFF and wait at least 10 seconds.
3. Turn ignition switch ON and select "DATA MONITOR" mode with CONSULT-III.
4. Start engine and let it idle for at least 1 minute.
5. Repeat next procedures three times.
 - Increase the engine speed up to 3,000 to 3,500 rpm and keep it for 2 minutes and 50 seconds to 3 minutes.

Never exceed 3 minutes.

- Fully released accelerator pedal and keep engine idle for about 5 seconds.
6. Repeat next procedure 20 times.
 - Quickly increase the engine speed up to 4,000 to 4,500 rpm or more and keep it for 25 to 30 seconds.

P0448 EVAP CANISTER VENT CONTROL VALVE

[MR18DE]

< DTC/CIRCUIT DIAGNOSIS >

- Fully released accelerator pedal and keep engine idle for at least 35 seconds.

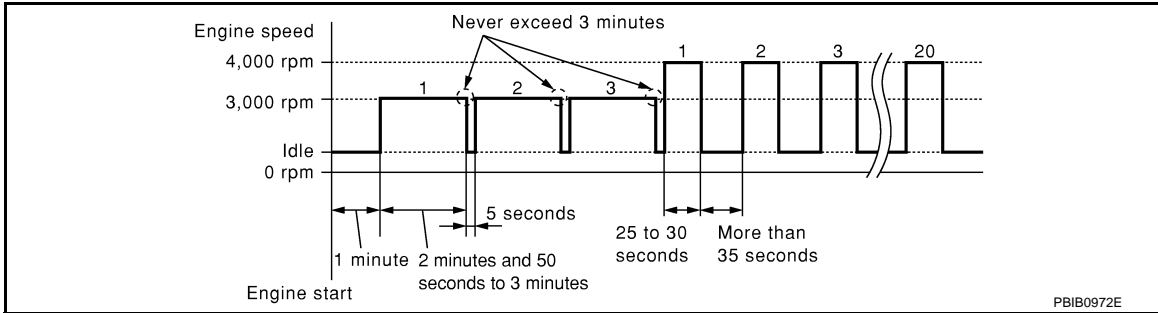

7. Check 1st trip DTC.

With GST

Follow the procedure "With CONSULT-III" above.

Is 1st trip DTC detected?

- YES >> Go to [EC-264, "Diagnosis Procedure"](#).
- NO >> INSPECTION END

Diagnosis Procedure

INFOID:000000004833374

1. CHECK RUBBER TUBE

1. Turn ignition switch OFF.
2. Disconnect rubber tube connected to EVAP canister vent control valve.
3. Check the rubber tube for clogging.

Is the inspection result normal?

- YES >> GO TO 2.
- NO >> Clean rubber tube using an air blower.

2. CHECK EVAP CANISTER VENT CONTROL VALVE

Refer to [EC-265, "Component Inspection"](#).

Is the inspection result normal?

- YES >> GO TO 3.
- NO >> Replace EVAP canister vent control valve.

3. CHECK IF EVAP CANISTER IS SATURATED WITH WATER

1. Remove EVAP canister with EVAP canister vent control valve and EVAP control system pressure sensor attached.
2. Check if water will drain from the EVAP canister.

Does water drain from EVAP canister?

- YES >> GO TO 4.
- NO >> GO TO 6.

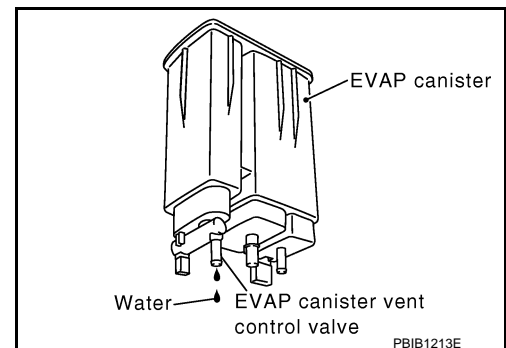

4. CHECK EVAP CANISTER

Weigh the EVAP canister with the EVAP canister vent control valve and EVAP control system pressure sensor attached.

The weight should be less than 1.9 kg (4.2 lb).

Is the inspection result normal?

- YES >> GO TO 6.
- NO >> GO TO 5.

5. DETECT MALFUNCTIONING PART

P0448 EVAP CANISTER VENT CONTROL VALVE

[MR18DE]

< DTC/CIRCUIT DIAGNOSIS >

Check the following.

- EVAP canister for damage
- EVAP hose between EVAP canister and vehicle frame for clogging or poor connection

>> Repair hose or replace EVAP canister.

6.CHECK EVAP CONTROL SYSTEM PRESSURE SENSOR CONNECTOR

1. Disconnect EVAP control system pressure sensor harness connector.
2. Check connectors for water.

Water should not exist.

Is the inspection result normal?

YES >> GO TO 7.

NO >> Replace EVAP control system pressure sensor.

7.CHECK EVAP CONTROL SYSTEM PRESSURE SENSOR

Refer to [EC-269, "Component Inspection"](#).

Is the inspection result normal?

YES >> GO TO 8.

NO >> Replace EVAP control system pressure sensor.

8.CHECK INTERMITTENT INCIDENT

Refer to [GI-34, "Intermittent Incident"](#).

>> INSPECTION END

Component Inspection

INFOID:000000004833375

1.CHECK EVAP CANISTER VENT CONTROL VALVE-I

1. Turn ignition switch OFF.
2. Remove EVAP canister vent control valve from EVAP canister.
3. Check portion (A) of EVAP canister vent control valve for being rusted.

Is it rusted?

YES >> Replace EVAP canister vent control valve.

NO >> GO TO 2.

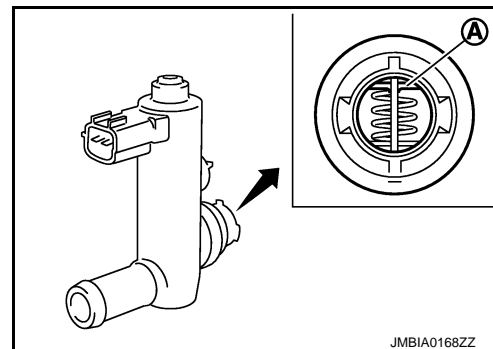

2.CHECK EVAP CANISTER VENT CONTROL VALVE-II

With CONSULT-III

1. Reconnect harness connectors disconnected.
2. Turn ignition switch ON.
3. Perform "VENT CONTROL/V" in "ACTIVE TEST" mode.

P0448 EVAP CANISTER VENT CONTROL VALVE

[MR18DE]

< DTC/CIRCUIT DIAGNOSIS >

4. Check air passage continuity and operation delay time.
Make sure new O-ring is installed properly.

VENT CONT/V condition	Air passage continuity between (A) and (B)
ON	Not existed
OFF	Existed

Operation takes less than 1 second.

⊗ Without CONSULT-III

Check air passage continuity and operation delay time under the following conditions.

Make sure new O-ring is installed properly.

Condition	Air passage continuity between (A) and (B)
12 V direct current supply between terminals (1) and (2)	Not existed
OFF	Existed

Operation takes less than 1 second.

Is the inspection result normal?

YES >> GO TO 3.

NO >> Replace EVAP canister vent control valve.

3. CHECK EVAP CANISTER VENT CONTROL VALVE-III

Ⓟ With CONSULT-III

- Clean the air passage [portion (A) to (B)] of EVAP canister vent control valve using an air blower.
- Perform "VENT CONTROL/V" in "ACTIVE TEST" mode.
- Check air passage continuity and operation delay time.
Make sure new O-ring is installed properly.

VENT CONT/V condition	Air passage continuity between (A) and (B)
ON	Not existed
OFF	Existed

Operation takes less than 1 second.

⊗ Without CONSULT-III

- Clean the air passage [portion (A) to (B)] of EVAP canister vent control valve using an air blower.
- Check air passage continuity and operation delay time under the following conditions.

Make sure new O-ring is installed properly.

Condition	Air passage continuity between (A) and (B)
12 V direct current supply between terminals (1) and (2)	Not existed
OFF	Existed

Operation takes less than 1 second.

Is the inspection result normal?

YES >> INSPECTION END

NO >> Replace EVAP canister vent control valve.

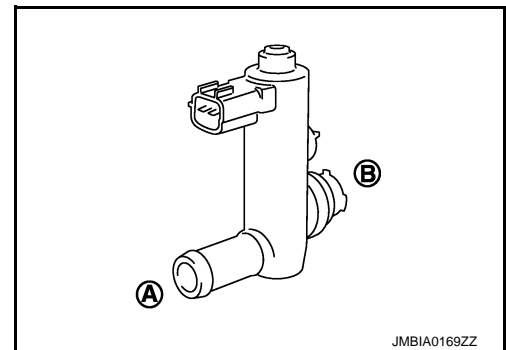
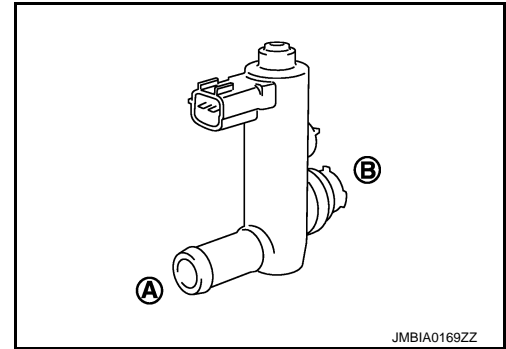

P0451 EVAP CONTROL SYSTEM PRESSURE SENSOR

< DTC/CIRCUIT DIAGNOSIS >

[MR18DE]

P0451 EVAP CONTROL SYSTEM PRESSURE SENSOR

Description

INFOID:000000004833376

The EVAP control system pressure sensor detects pressure in the purge line. The sensor output voltage to the ECM increases as pressure increases.

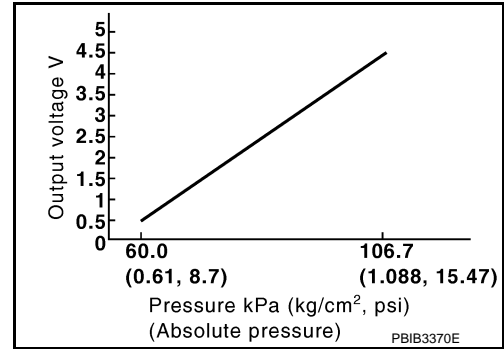

DTC Logic

INFOID:000000004833377

DTC DETECTION LOGIC

DTC No.	Trouble diagnosis name	DTC detecting condition	Possible cause
P0451	EVAP control system pressure sensor performance	ECM detects a sloshing signal from the EVAP control system pressure sensor	<ul style="list-style-type: none"> Harness or connectors (EVAP control system pressure sensor circuit is shorted.) [Crankshaft position sensor (POS) circuit is shorted.] (Accelerator pedal position sensor circuit is shorted.) (Refrigerant pressure sensor circuit is shorted.) (Battery current sensor circuit is shorted.) EVAP control system pressure sensor Crankshaft position sensor (POS) Accelerator pedal position sensor Refrigerant pressure sensor Battery current sensor

DTC CONFIRMATION PROCEDURE

1. PRECONDITIONING

If DTC Confirmation Procedure has been previously conducted, always turn ignition switch OFF and wait at least 10 seconds before conducting the next test.

>> GO TO 2.

2. PERFORM DTC CONFIRMATION PROCEDURE

- Turn ignition switch OFF and wait at least 10 seconds.
- Start engine and wait at least 40 seconds.

NOTE:

Do not depress accelerator pedal even slightly.

- Check 1st trip DTC.

Is 1st trip DTC detected?

YES >> Go to [EC-267. "Diagnosis Procedure"](#).

NO >> INSPECTION END

Diagnosis Procedure

INFOID:000000004833378

1. CHECK GROUND CONNECTION

- Turn ignition switch OFF.
- Check ground connection E38. Refer to [GI-37. "Circuit Inspection"](#).

P0451 EVAP CONTROL SYSTEM PRESSURE SENSOR

[MR18DE]

< DTC/CIRCUIT DIAGNOSIS >

Is the inspection result normal?

- YES >> GO TO 2.
NO >> Repair or replace ground connection.

2.CHECK EVAP CONTROL SYSTEM PRESSURE SENSOR CONNECTOR FOR WATER

1. Disconnect EVAP control system pressure sensor harness connector.
2. Check sensor harness connector for water.

Water should not exist.

Is the inspection result normal?

- YES >> GO TO 3.
NO >> Repair or replace harness connector.

3.CHECK EVAP CONTROL SYSTEM PRESSURE SENSOR POWER SUPPLY CIRCUIT

1. Turn ignition switch ON.
2. Check the voltage between EVAP control system pressure sensor harness connector and ground.

EVAP control system pressure sensor		Ground	Voltage
Connector	Terminal		
B21	3	Ground	Approx. 5 V

Is the inspection result normal?

- YES >> GO TO 8.
NO >> GO TO 4.

4.CHECK SENSOR POWER SUPPLY CIRCUITS

Check harness for short to power and short to ground, between the following terminals.

ECM		Sensor		
Connector	Terminal	Name	Connector	Terminal
F8	74	Refrigerant pressure sensor	E49	3
	75	CKP sensor (POS)	F20	1
	76	EVAP control system pressure sensor	B21	3
	77	Battery current sensor	F51	1
E16	102	APP sensor	E110	5

Is the inspection result normal?

- YES >> GO TO 5.
NO >> Repair short to ground or short to power in harness or connectors.

5.CHECK COMPONENTS

Check the following.

- Battery current sensor (Refer to [EC-327, "Component Inspection"](#).)
- Crankshaft position sensor (POS) (Refer to [EC-228, "Component Inspection"](#).)
- Refrigerant pressure sensor (Refer to [EC-414, "Diagnosis Procedure"](#).)

Is the inspection result normal?

- YES >> GO TO 6.
NO >> Replace malfunctioning component.

6.CHECK APP SENSOR

Refer to [EC-370, "Component Inspection"](#).

Is the inspection result normal?

- YES >> GO TO 9.
NO >> GO TO 7.

P0451 EVAP CONTROL SYSTEM PRESSURE SENSOR

< DTC/CIRCUIT DIAGNOSIS >

[MR18DE]

7. REPLACE ACCELERATOR PEDAL ASSEMBLY

1. Replace accelerator pedal assembly
2. Perform [EC-370, "Special Repair Requirement"](#).

>> INSPECTION END

8. CHECK EVAP CONTROL SYSTEM PRESSURE SENSOR

Refer to [EC-269, "Component Inspection"](#).

Is the inspection result normal?

- YES >> GO TO 9.
NO >> Replace EVAP control system pressure sensor.

9. CHECK INTERMITTENT INCIDENT

Refer to [GI-34, "Intermittent Incident"](#).

>> INSPECTION END

Component Inspection

INFOID:000000004633379

1. CHECK EVAP CONTROL SYSTEM PRESSURE SENSOR

1. Turn ignition switch OFF.
2. Remove EVAP control system pressure sensor with its harness connector connected from EVAP canister. **Always replace O-ring with a new one.**
3. Install a vacuum pump to EVAP control system pressure sensor.
4. Turn ignition switch ON and check output voltage between ECM harness connector and ground under the following conditions.

ECM		Condition	Voltage
Connector	Terminal	[Applied vacuum kPa (kg/cm ² , psi)]	
F8	42 (EVAP control system pressure sensor signal)	Not applied	1.8 - 4.8 V
		-26.7 (-0.272, -3.87)	2.1 to 2.5 V lower than above value

CAUTION:

- Always calibrate the vacuum pump gauge when using it.
- Do not apply below -93.3 kPa (-0.952 kg/cm², -13.53 psi) or pressure over 101.3 kPa (1.033 kg/cm², 14.69 psi).

Is the inspection result normal?

- YES >> INSPECTION END
NO >> Replace EVAP control system pressure sensor

P0452 EVAP CONTROL SYSTEM PRESSURE SENSOR

< DTC/CIRCUIT DIAGNOSIS >

[MR18DE]

P0452 EVAP CONTROL SYSTEM PRESSURE SENSOR

Description

INFOID:000000004833380

The EVAP control system pressure sensor detects pressure in the purge line. The sensor output voltage to the ECM increases as pressure increases.

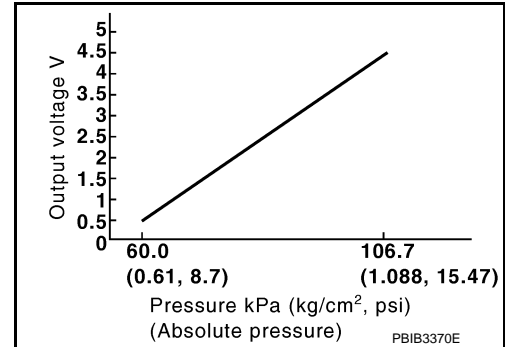

DTC Logic

INFOID:000000004833381

DTC DETECTION LOGIC

DTC No.	Trouble diagnosis name	DTC detecting condition	Possible cause
P0452	EVAP control system pressure sensor low input	An excessively low voltage from the sensor is sent to ECM.	<ul style="list-style-type: none"> • Harness or connectors (EVAP control system pressure sensor circuit is open or shorted.) • [Crankshaft position sensor (POS) circuit is shorted.] • (Accelerator pedal position sensor circuit is shorted.) • (Refrigerant pressure sensor circuit is shorted.) • (Battery current sensor circuit is shorted.) • EVAP control system pressure sensor • Crankshaft position sensor (POS) • Accelerator pedal position sensor • Refrigerant pressure sensor • Battery current sensor

DTC CONFIRMATION PROCEDURE

1. PRECONDITIONING

If DTC Confirmation Procedure has been previously conducted, always turn ignition switch OFF and wait at least 10 seconds before conducting the next test.

TESTING CONDITION:

Always perform test at a temperature of 5°C (41°F) or more.

>> GO TO 2.

2. PERFORM DTC CONFIRMATION PROCEDURE

With CONSULT-III

1. Start engine and warm it up to normal operating temperature.
2. Turn ignition switch OFF and wait at least 10 seconds.
3. Turn ignition switch ON.
4. Select "DATA MONITOR" mode with CONSULT-III.
5. Make sure that "FUEL T/TMP SE" indication is more than 0°C (32°F).
6. Start engine and wait at least 20 seconds.
7. Check 1st trip DTC.

With GST

1. Start engine and warm it up to normal operating temperature.
2. Set voltmeter probes to ECM harness connector and ground as per the following.

P0452 EVAP CONTROL SYSTEM PRESSURE SENSOR

< DTC/CIRCUIT DIAGNOSIS >

[MR18DE]

ECM		Ground
Connector	Terminal	
F8	43 (Fuel tank temperature sensor signal)	Ground

3. Make sure that the voltage is less than 4.2 V.
4. Turn ignition switch OFF and wait at least 10 seconds.
5. Start engine and wait at least 20 seconds.
6. Check 1st trip DTC.

Is 1st trip DTC detected?

- YES >> Go to [EC-271, "Diagnosis Procedure"](#).
 NO >> INSPECTION END

Diagnosis Procedure

INFOID:000000004833383

1. CHECK GROUND CONNECTION

1. Turn ignition switch OFF.
2. Check ground connection E38. Refer to [GI-37, "Circuit Inspection"](#).

Is the inspection result normal?

- YES >> GO TO 2.
 NO >> Repair or replace ground connection.

2. CHECK CONNECTOR

1. Disconnect EVAP control system pressure sensor harness connector.
2. Check sensor harness connector for water.

Water should not exist.

Is the inspection result normal?

- YES >> GO TO 3.
 NO >> Repair or replace harness connector.

3. CHECK EVAP CONTROL SYSTEM PRESSURE SENSOR POWER SUPPLY CIRCUIT-I

1. Turn ignition switch ON.
2. Check the voltage between EVAP control system pressure sensor harness connector and ground.

EVAP control system pressure sensor		Ground	Voltage
Connector	Terminal		
B21	3	Ground	Approx. 5 V

Is the inspection result normal?

- YES >> GO TO 10.
 NO >> GO TO 4.

4. CHECK EVAP CONTROL SYSTEM PRESSURE SENSOR POWER SUPPLY CIRCUIT-II

1. Turn ignition switch OFF.
2. Disconnect ECM harness connector.
3. Check the continuity between EVAP control system pressure sensor harness connector and ECM harness connector.

EVAP control system pressure sensor		ECM		Continuity
Connector	Terminal	Connector	Terminal	
B21	3	F8	76	Existed

Is the inspection result normal?

P0452 EVAP CONTROL SYSTEM PRESSURE SENSOR

[MR18DE]

< DTC/CIRCUIT DIAGNOSIS >

- YES >> GO TO 6.
- NO >> GO TO 5.

5. DETECT MALFUNCTIONING PART

Check the following.

- Harness connectors B4, M79
- Harness connectors M77, E105
- Harness connectors E8, F1
- Harness for open or short between EVAP control system pressure sensor and ECM

>> Repair open circuit or short to ground or short to power in harness or connectors.

6. CHECK SENSOR POWER SUPPLY CIRCUIT

Check harness for short to power and short to ground, between the following terminals.

ECM		Sensor		
Connector	Terminal	Name	Connector	Terminal
F8	74	Refrigerant pressure sensor	E49	3
	75	CKP sensor (POS)	F20	1
	76	EVAP control system pressure sensor	B21	3
	77	Battery current sensor	F51	1
E16	102	APP sensor	E110	5

Is the inspection result normal?

- YES >> GO TO 7.
- NO >> Repair short to ground or short to power in harness or connectors.

7. CHECK COMPONENTS

Check the following.

- Battery current sensor (Refer to [EC-327, "Component Inspection"](#).)
- Crankshaft position sensor (POS) (Refer to [EC-228, "Component Inspection"](#).)
- Refrigerant pressure sensor (Refer to [EC-414, "Diagnosis Procedure"](#).)

Is the inspection result normal?

- YES >> GO TO 8.
- NO >> Replace malfunctioning component.

8. CHECK APP SENSOR

Refer to [EC-370, "Component Inspection"](#).

Is the inspection result normal?

- YES >> GO TO 10.
- NO >> GO TO 9.

9. REPLACE ACCELERATOR PEDAL ASSEMBLY

1. Replace accelerator pedal assembly
2. Perform [EC-370, "Special Repair Requirement"](#).

>> INSPECTION END

10. CHECK EVAP CONTROL SYSTEM PRESSURE SENSOR GROUND CIRCUIT FOR OPEN AND SHORT

1. Turn ignition switch OFF.
2. Disconnect ECM harness connector.
3. Check the continuity between EVAP control system pressure sensor harness connector and ECM harness connector.

P0452 EVAP CONTROL SYSTEM PRESSURE SENSOR

< DTC/CIRCUIT DIAGNOSIS >

[MR18DE]

EVAP control system pressure sensor		ECM		Continuity
Connector	Terminal	Connector	Terminal	
B21	1	F8	51	Existed

4. Also check harness for short to ground and short to power.

Is the inspection result normal?

YES >> GO TO 12.

NO >> GO TO 11.

11.DETECT MALFUNCTIONING PART

Check the following.

- Harness connectors B4, M79
- Harness connectors M77, E105
- Harness connectors E8, F1
- Harness for open or short between EVAP control system pressure sensor and ECM

>> Repair open circuit or short to ground or short to power in harness or connectors.

12.CHECK EVAP CONTROL SYSTEM PRESSURE SENSOR INPUT SIGNAL CIRCUIT FOR OPEN AND SHORT

1. Check the continuity between EVAP control system pressure sensor harness connector and ECM harness connector.

EVAP control system pressure sensor		ECM		Continuity
Connector	Terminal	Connector	Terminal	
B21	2	F8	42	Existed

2. Also check harness for short to ground and short to power.

Is the inspection result normal?

YES >> GO TO 14.

NO >> GO TO 13.

13.DETECT MALFUNCTIONING PART

Check the following.

- Harness connectors B4, M79
- Harness connectors M77, E105
- Harness connectors E8, F1
- Harness for open or short between EVAP control system pressure sensor and ECM

>> Repair open circuit or short to ground or short to power in harness or connectors.

14.CHECK EVAP CONTROL SYSTEM PRESSURE SENSOR

Refer to [EC-274, "Component Inspection"](#).

Is the inspection result normal?

YES >> GO TO 15.

NO >> Replace EVAP control system pressure sensor.

15.CHECK INTERMITTENT INCIDENT

Refer to [GI-34, "Intermittent Incident"](#).

>> INSPECTION END

P0452 EVAP CONTROL SYSTEM PRESSURE SENSOR

< DTC/CIRCUIT DIAGNOSIS >

[MR18DE]

Component Inspection

INFOID:000000004833384

1. CHECK EVAP CONTROL SYSTEM PRESSURE SENSOR

1. Turn ignition switch OFF.
2. Remove EVAP control system pressure sensor with its harness connector connected from EVAP canister.
Always replace O-ring with a new one.
3. Install a vacuum pump to EVAP control system pressure sensor.
4. Turn ignition switch ON and check output voltage between ECM harness connector and ground under the following conditions.

ECM		Condition	Voltage
Connector	Terminal	[Applied vacuum kPa (kg/cm ² , psi)]	
F8	42 (EVAP control system pressure sensor signal)	Not applied	1.8 - 4.8 V
		-26.7 (-0.272, -3.87)	2.1 to 2.5 V lower than above value

CAUTION:

- Always calibrate the vacuum pump gauge when using it.
- Do not apply below -93.3 kPa (-0.952 kg/cm², -13.53 psi) or pressure over 101.3 kPa (1.033 kg/cm², 14.69 psi).

Is the inspection result normal?

- YES >> INSPECTION END
NO >> Replace EVAP control system pressure sensor

P0453 EVAP CONTROL SYSTEM PRESSURE SENSOR

< DTC/CIRCUIT DIAGNOSIS >

[MR18DE]

P0453 EVAP CONTROL SYSTEM PRESSURE SENSOR

Description

INFOID:000000004833385

The EVAP control system pressure sensor detects pressure in the purge line. The sensor output voltage to the ECM increases as pressure increases.

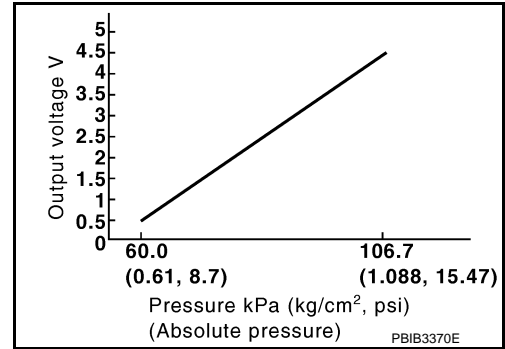

DTC Logic

INFOID:000000004833386

DTC DETECTION LOGIC

DTC No.	Trouble diagnosis name	DTC detecting condition	Possible cause
P0453	EVAP control system pressure sensor high input	An excessively high voltage from the sensor is sent to ECM.	<ul style="list-style-type: none"> • Harness or connectors (EVAP control system pressure sensor circuit is open or shorted.) [Crankshaft position sensor (POS) circuit is shorted.] (Accelerator pedal circuit is shorted.) (Refrigerant pressure sensor circuit is shorted.) (Battery current sensor circuit is shorted.) • EVAP control system pressure sensor • Crankshaft position sensor (POS) • Accelerator pedal position sensor • Refrigerant pressure sensor • EVAP canister vent control valve • EVAP canister • Rubber hose from EVAP canister vent control valve to vehicle frame • Battery current sensor

DTC CONFIRMATION PROCEDURE

1. PRECONDITIONING

If DTC Confirmation Procedure has been previously conducted, always turn ignition switch OFF and wait at least 10 seconds before conducting the next test.

TESTING CONDITION:

Always perform test at a temperature of 5°C (41°F) or more.

>> GO TO 2.

2. PERFORM DTC CONFIRMATION PROCEDURE

With CONSULT-III

1. Start engine and warm it up to normal operating temperature.
2. Turn ignition switch OFF and wait at least 10 seconds.
3. Turn ignition switch ON.
4. Select "DATA MONITOR" mode with CONSULT-III.
5. Make sure that "FUEL T/TMP SE" indication is more than 0°C (32°F).
6. Start engine and wait at least 20 seconds.
7. Check 1st trip DTC.

With GST

P0453 EVAP CONTROL SYSTEM PRESSURE SENSOR

[MR18DE]

< DTC/CIRCUIT DIAGNOSIS >

1. Start engine and warm it up to normal operating temperature.
2. Set voltmeter probes to ECM harness connector and ground as per the following.

ECM		Ground
Connector	Terminal	
F8	43 (Fuel tank temperature sensor signal)	Ground

3. Make sure that the voltage is less than 4.2 V.
4. Turn ignition switch OFF and wait at least 10 seconds.
5. Start engine and wait at least 20 seconds.
6. Check 1st trip DTC.

Is 1st trip DTC detected?

- YES >> Go to [EC-276, "Diagnosis Procedure"](#).
NO >> INSPECTION END

Diagnosis Procedure

INFOID:000000004833388

1. CHECK GROUND CONNECTION

1. Turn ignition switch OFF.
2. Check ground connection E38. Refer to [GI-37, "Circuit Inspection"](#).

Is the inspection result normal?

- YES >> GO TO 2.
NO >> Repair or replace ground connection.

2. CHECK CONNECTOR

1. Disconnect EVAP control system pressure sensor harness connector.
2. Check sensor harness connector for water.

Water should not exist.

Is the inspection result normal?

- YES >> GO TO 3.
NO >> Repair or replace harness connector.

3. CHECK EVAP CONTROL SYSTEM PRESSURE SENSOR POWER SUPPLY CIRCUIT

1. Turn ignition switch ON.
2. Check the voltage between EVAP control system pressure sensor harness connector and ground.

EVAP control system pressure sensor		Ground	Voltage
Connector	Terminal		
B21	3	Ground	Approx. 5 V

Is the inspection result normal?

- YES >> GO TO 10.
NO >> GO TO 4.

4. CHECK EVAP CONTROL SYSTEM PRESSURE SENSOR POWER SUPPLY CIRCUIT-II

1. Turn ignition switch OFF.
2. Disconnect ECM harness connector.
3. Check the continuity between EVAP control system pressure sensor harness connector and ECM harness connector.

P0453 EVAP CONTROL SYSTEM PRESSURE SENSOR

< DTC/CIRCUIT DIAGNOSIS >

[MR18DE]

EVAP control system pressure sensor		ECM		Continuity
Connector	Terminal	Connector	Terminal	
B21	3	F8	76	Existed

Is the inspection result normal?

YES >> GO TO 6.

NO >> GO TO 5.

5. DETECT MALFUNCTIONING PART

Check the following.

- Harness connectors B4, M79
- Harness connectors M77, E105
- Harness connectors E8, F1
- Harness for open or short between EVAP control system pressure sensor and ECM

>> Repair open circuit or short to ground or short to power in harness or connectors.

6. CHECK SENSOR POWER SUPPLY CIRCUIT

Check harness for short to power and short to ground, between the following terminals.

ECM		Sensor		
Connector	Terminal	Name	Connector	Terminal
F8	74	Refrigerant pressure sensor	E49	3
	75	CKP sensor (POS)	F20	1
	76	EVAP control system pressure sensor	B21	3
	77	Battery current sensor	F51	1
E16	102	APP sensor	E110	5

Is the inspection result normal?

YES >> GO TO 7.

NO >> Repair short to ground or short to power in harness or connectors.

7. CHECK COMPONENTS

Check the following.

- Battery current sensor (Refer to [EC-327, "Component Inspection"](#).)
- Crankshaft position sensor (POS) (Refer to [EC-228, "Component Inspection"](#).)
- Refrigerant pressure sensor (Refer to [EC-414, "Diagnosis Procedure"](#).)

Is the inspection result normal?

YES >> GO TO 8.

NO >> Replace malfunctioning component.

8. CHECK APP SENSOR

Refer to [EC-370, "Component Inspection"](#).

Is the inspection result normal?

YES >> GO TO 10.

NO >> GO TO 9.

9. REPLACE ACCELERATOR PEDAL ASSEMBLY

1. Replace accelerator pedal assembly
2. Perform [EC-370, "Special Repair Requirement"](#).

>> INSPECTION END

10. CHECK EVAP CONTROL SYSTEM PRESSURE SENSOR GROUND CIRCUIT FOR OPEN AND

P0453 EVAP CONTROL SYSTEM PRESSURE SENSOR

[MR18DE]

< DTC/CIRCUIT DIAGNOSIS >

SHORT

1. Turn ignition switch OFF.
2. Disconnect ECM harness connector.
3. Check the continuity between EVAP control system pressure sensor harness connector and ECM harness connector.

EVAP control system pressure sensor		ECM		Continuity
Connector	Terminal	Connector	Terminal	
B21	1	F8	51	Existed

4. Also check harness for short to ground and short to power.

Is the inspection result normal?

YES >> GO TO 12.

NO >> GO TO 11.

11.DETECT MALFUNCTIONING PART

Check the following.

- Harness connectors B4, M79
- Harness connectors M77, E105
- Harness connectors E8, F1
- Harness for open or short between EVAP control system pressure sensor and ECM

>> Repair open circuit or short to ground or short to power in harness or connectors.

12.CHECK EVAP CONTROL SYSTEM PRESSURE SENSOR INPUT SIGNAL CIRCUIT FOR OPEN AND SHORT

1. Check the continuity between EVAP control system pressure sensor harness connector and ECM harness connector.

EVAP control system pressure sensor		ECM		Continuity
Connector	Terminal	Connector	Terminal	
B21	2	F8	42	Existed

2. Also check harness for short to ground and short to power.

Is the inspection result normal?

YES >> GO TO 14.

NO >> GO TO 13.

13.DETECT MALFUNCTIONING PART

Check the following.

- Harness connectors B4, M79
- Harness connectors M77, E105
- Harness connectors E8, F1
- Harness for open or short between EVAP control system pressure sensor and ECM

>> Repair open circuit or short to ground or short to power in harness or connectors.

14.CHECK RUBBER TUBE

1. Disconnect rubber tube connected to EVAP canister vent control valve.
2. Check the rubber tube for clogging.

Is the inspection result normal?

YES >> GO TO 15.

NO >> Clean the rubber tube using an air blower, repair or replace rubber tube.

15.CHECK EVAP CANISTER VENT CONTROL VALVE

P0453 EVAP CONTROL SYSTEM PRESSURE SENSOR

[MR18DE]

< DTC/CIRCUIT DIAGNOSIS >

Refer to [EC-261, "Component Inspection"](#).

Is the inspection result normal?

YES >> GO TO 16.

NO >> Replace EVAP canister vent control valve.

16. CHECK EVAP CONTROL SYSTEM PRESSURE SENSOR

Refer to [EC-279, "Component Inspection"](#).

Is the inspection result normal?

YES >> GO TO 17.

NO >> Replace EVAP control system pressure sensor.

17. CHECK IF EVAP CANISTER IS SATURATED WITH WATER

1. Remove EVAP canister with EVAP canister vent control valve and EVAP control system pressure sensor attached.
2. Check if water will drain from the EVAP canister.

Does water drain from EVAP canister?

YES >> GO TO 18.

NO >> GO TO 20.

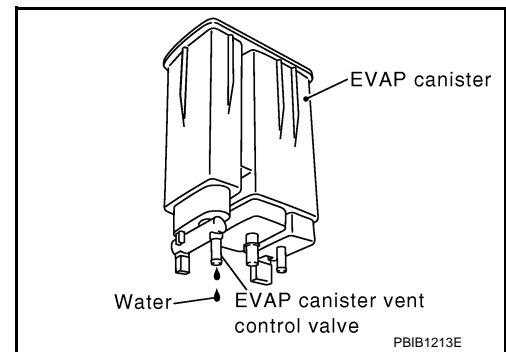

18. CHECK EVAP CANISTER

Weigh the EVAP canister with the EVAP canister vent control valve and EVAP control system pressure sensor attached.

The weight should be less than 1.9 kg (4.2 lb).

Is the inspection result normal?

YES >> GO TO 20.

NO >> GO TO 19.

19. DETECT MALFUNCTIONING PART

Check the following.

- EVAP canister for damage
- EVAP hose between EVAP canister and vehicle frame for clogging or poor connection

>> Repair hose or replace EVAP canister.

20. CHECK INTERMITTENT INCIDENT

Refer to [GI-34, "Intermittent Incident"](#).

>> INSPECTION END

Component Inspection

INFOID:000000004833389

1. CHECK EVAP CONTROL SYSTEM PRESSURE SENSOR

1. Turn ignition switch OFF.
2. Remove EVAP control system pressure sensor with its harness connector connected from EVAP canister.
Always replace O-ring with a new one.
3. Install a vacuum pump to EVAP control system pressure sensor.
4. Turn ignition switch ON and check output voltage between ECM harness connector and ground under the following conditions.

P0453 EVAP CONTROL SYSTEM PRESSURE SENSOR

< DTC/CIRCUIT DIAGNOSIS >

[MR18DE]

ECM		Condition	Voltage
Connector	Terminal	[Applied vacuum kPa (kg/cm ² , psi)]	
F8	42 (EVAP control system pressure sensor signal)	Not applied	1.8 - 4.8 V
		-26.7 (-0.272, -3.87)	2.1 to 2.5 V lower than above value

CAUTION:

- Always calibrate the vacuum pump gauge when using it.
- Do not apply below -93.3 kPa (-0.952 kg/cm², -13.53 psi) or pressure over 101.3 kPa (1.033 kg/cm², 14.69 psi).

Is the inspection result normal?

YES >> INSPECTION END

NO >> Replace EVAP control system pressure sensor

P0455 EVAP CONTROL SYSTEM

< DTC/CIRCUIT DIAGNOSIS >

[MR18DE]

P0455 EVAP CONTROL SYSTEM

DTC Logic

INFOID:000000004833390

DTC DETECTION LOGIC

This diagnosis detects a very large leak (fuel filler cap fell off etc.) in EVAP system between the fuel tank and EVAP canister purge volume control solenoid valve.

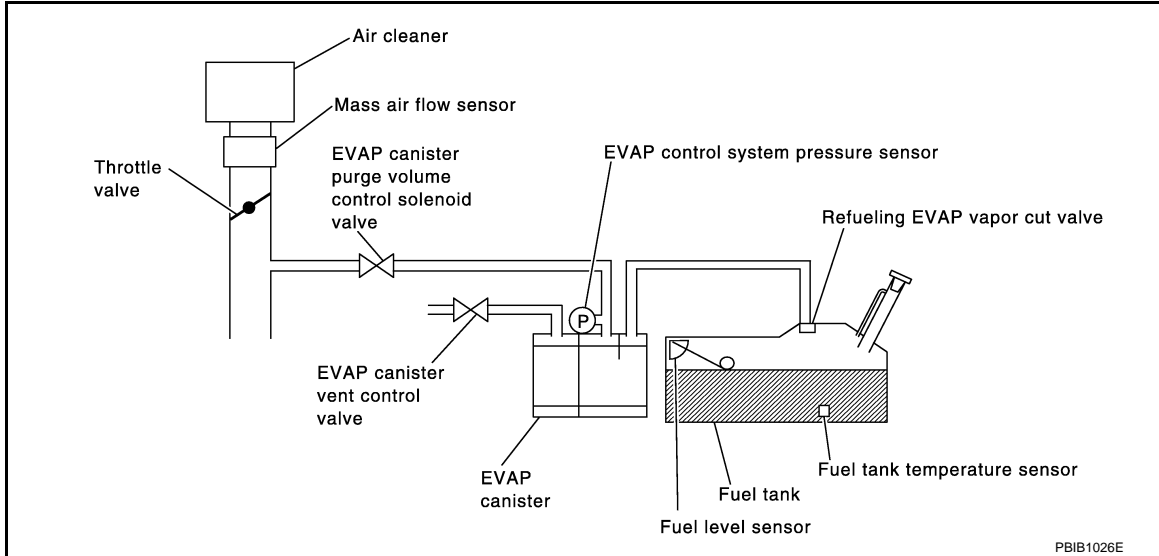

DTC No.	Trouble diagnosis name	DTC detecting condition	Possible cause
P0455	EVAP control system gross leak detected	EVAP control system has a very large leak such as fuel filler cap fell off, EVAP control system does not operate properly.	<ul style="list-style-type: none"> Fuel filler cap remains open or fails to close. Incorrect fuel tank vacuum relief valve Incorrect fuel filler cap used Foreign matter caught in fuel filler cap. Leak is in line between intake manifold and EVAP canister purge volume control solenoid valve. Foreign matter caught in EVAP canister vent control valve. EVAP canister or fuel tank leaks EVAP purge line (pipe and rubber tube) leaks EVAP purge line rubber tube bent. Loose or disconnected rubber tube EVAP canister vent control valve and the circuit EVAP canister purge volume control solenoid valve and the circuit Fuel tank temperature sensor O-ring of EVAP canister vent control valve is missing or damaged. EVAP control system pressure sensor Refueling EVAP vapor cut valve ORVR system leaks Drain filter

CAUTION:

- Use only a genuine NISSAN fuel filler cap as a replacement. If an incorrect fuel filler cap is used, the MIL may come on.
- If the fuel filler cap is not tightened properly, the MIL may come on.
- Use only a genuine NISSAN rubber tube as a replacement.

DTC CONFIRMATION PROCEDURE

1. PRECONDITIONING

P0455 EVAP CONTROL SYSTEM

[MR18DE]

< DTC/CIRCUIT DIAGNOSIS >

CAUTION:

Never remove fuel filler cap during the DTC CONFIRMATION PROCEDURE.

If DTC Confirmation Procedure has been previously conducted, always turn ignition switch OFF and wait at least 10 seconds before conducting the next test.

NOTE:

Make sure that EVAP hoses are connected to EVAP canister purge volume control solenoid valve properly.

TESTING CONDITION:

- Perform "DTC WORK SUPPORT" when the fuel level is between 1/4 and 3/4 full, and vehicle is placed on flat level surface.
- Open engine hood before conducting the following procedures.

Do you have CONSULT-III?

YES >> GO TO 2.

NO >> GO TO 4.

2.PERFORM DTC CONFIRMATION PROCEDURE

With CONSULT-III

1. Tighten fuel filler cap securely until ratcheting sound is heard.
2. Turn ignition switch ON.
3. Turn ignition switch OFF and wait at least 10 seconds.
4. Turn ignition switch ON and select "DATA MONITOR" mode with CONSULT-III.
5. Make sure that the following conditions are met.
COOLAN TEMP/S: 0 - 100°C (32 - 212°F)
INT/A TEMP SE: 0 - 60°C (32 - 140°F)
6. Select "EVAP SML LEAK P0442/P1442" of "EVAPORATIVE SYSTEM" in "DTC WORK SUPPORT" mode with CONSULT-III.

Follow the instruction displayed.

NOTE:

If the engine speed cannot be maintained within the range displayed on the CONSULT-III screen, go to [EC-12, "BASIC INSPECTION : Special Repair Requirement"](#).

Which is displayed on CONSULT-III screen?

OK >> INSPECTION END

NG >> GO TO 3.

3.CHECK DTC

Check DTC.

Which DTC is detected?

P0455 >> Go to [EC-282, "Diagnosis Procedure"](#).

P0442 >> Go to [EC-245, "Diagnosis Procedure"](#).

4.PERFORM DTC CONFIRMATION PROCEDURE

With GST

NOTE:

Be sure to read the explanation of DRIVING PATTERN in [EC-451, "How to Set SRT Code"](#) before driving vehicle.

1. Start engine.
2. Drive vehicle according to DRIVING PATTERN.
3. Stop vehicle.
4. Turn ignition switch OFF, wait at least 10 seconds and then turn ON.
5. Check 1st trip DTC.

Is 1st trip DTC detected?

YES-1 >> P0455: Go to [EC-282, "Diagnosis Procedure"](#).

YES-2 >> P0442: Go to [EC-245, "Diagnosis Procedure"](#).

YES-3 >> P0441: Go to [EC-240, "Diagnosis Procedure"](#).

NO >> INSPECTION END

Diagnosis Procedure

INFOID:000000004833391

1.CHECK FUEL FILLER CAP DESIGN

P0455 EVAP CONTROL SYSTEM

[MR18DE]

< DTC/CIRCUIT DIAGNOSIS >

1. Turn ignition switch OFF.
2. Check for genuine NISSAN fuel filler cap design.

Is the inspection result normal?

- YES >> GO TO 2.
NO >> Replace with genuine NISSAN fuel filler cap.

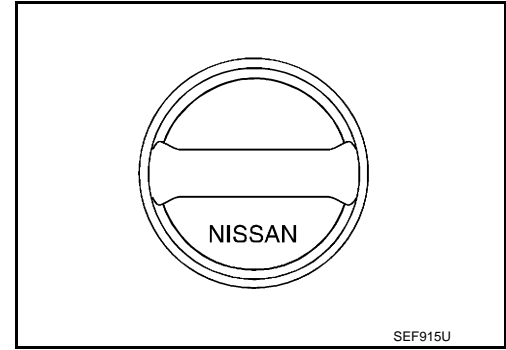

2.CHECK FUEL FILLER CAP INSTALLATION

Check that the cap is tightened properly by rotating the cap clockwise.

Is the inspection result normal?

- YES >> GO TO 3.
NO >> Open fuel filler cap, then clean cap and fuel filler neck threads using air blower. Then retighten until ratcheting sound is heard.

3.CHECK FUEL FILLER CAP FUNCTION

Check for air releasing sound while opening the fuel filler cap.

Is the inspection result normal?

- YES >> GO TO 5.
NO >> GO TO 4.

4.CHECK FUEL TANK VACUUM RELIEF VALVE

Refer to [EC-285. "Component Inspection \(Fuel filler cap\)".](#)

Is the inspection result normal?

- YES >> GO TO 5.
NO >> Replace fuel filler cap with a genuine one.

5.CHECK EVAP PURGE LINE

Check EVAP purge line (pipe, rubber tube, fuel tank and EVAP canister) for cracks, improper connection or disconnection.

Refer to [EC-68. "System Description".](#)

Is the inspection result normal?

- YES >> GO TO 6.
NO >> Repair or reconnect the hose.

6.CLEAN EVAP PURGE LINE

Clean EVAP purge line (pipe and rubber tube) using air blower.

>> GO TO 7.

7.CHECK DRAIN FILTER

Refer to [EC-286. "Component Inspection \(Drain filter\)".](#)

Is the inspection result normal?

- YES >> GO TO 8.
NO >> Replace drain filter.

8.CHECK EVAP CANISTER VENT CONTROL VALVE

Check the following.

- EVAP canister vent control valve is installed properly.
Refer to [EC-475. "Exploded View".](#)
- EVAP canister vent control valve.
Refer to [EC-261. "Component Inspection".](#)

< DTC/CIRCUIT DIAGNOSIS >

Is the inspection result normal?

YES >> GO TO 9.

NO >> Repair or replace EVAP canister vent control valve and O-ring.

9. CHECK FOR EVAP LEAK

Refer to [EC-473. "Inspection"](#).

Is there any leak in EVAP line?

YES >> Repair or replace.

NO-1 >> With CONSULT-III: GO TO 10.

NO-2 >> Without CONSULT-III: GO TO 11.

10. CHECK EVAP CANISTER PURGE VOLUME CONTROL SOLENOID VALVE OPERATION

With CONSULT-III

1. Disconnect vacuum hose to EVAP canister purge volume control solenoid valve at EVAP service port.
2. Start engine.
3. Perform "PURG VOL CONT/V" in "ACTIVE TEST" mode.
4. Touch "Qu" on CONSULT-III screen to increase "PURG VOL C/V" opening to 100%.
5. Check vacuum hose for vacuum.

Vacuum should exist.

Is the inspection result normal?

YES >> GO TO 13.

NO >> GO TO 12.

11. CHECK EVAP CANISTER PURGE VOLUME CONTROL SOLENOID VALVE OPERATION

Without CONSULT-III

1. Start engine and warm it up to normal operating temperature.
2. Stop engine.
3. Disconnect vacuum hose to EVAP canister purge volume control solenoid valve at EVAP service port.
4. Start engine and let it idle for at least 80 seconds.
5. Check vacuum hose for vacuum when revving engine up to 2,000 rpm.

Vacuum should exist.

Is the inspection result normal?

YES >> GO TO 14.

NO >> GO TO 12.

12. CHECK VACUUM HOSE

Check vacuum hoses for clogging or disconnection. Refer to [EC-68. "System Description"](#).

Is the inspection result normal?

YES-1 >> With CONSULT-III: GO TO 13.

YES-2 >> Without CONSULT-III: GO TO 14.

NO >> Repair or reconnect the hose.

13. CHECK EVAP CANISTER PURGE VOLUME CONTROL SOLENOID VALVE

With CONSULT-III

1. Start engine.
2. Perform "PURG VOL CONT/V" in "ACTIVE TEST" mode with CONSULT-III. Check that engine speed varies according to the valve opening.

Does engine speed vary according to the valve opening?

YES >> GO TO 15.

NO >> GO TO 14.

14. CHECK EVAP CANISTER PURGE VOLUME CONTROL SOLENOID VALVE

Refer to [EC-254. "Component Inspection"](#).

Is the inspection result normal?

YES >> GO TO 15.

P0455 EVAP CONTROL SYSTEM

[MR18DE]

< DTC/CIRCUIT DIAGNOSIS >

NO >> Replace EVAP canister purge volume control solenoid valve.

15.CHECK FUEL TANK TEMPERATURE SENSOR

Refer to [EC-210. "Component Inspection"](#).

Is the inspection result normal?

YES >> GO TO 16.

NO >> Replace fuel level sensor unit.

16.CHECK EVAP CONTROL SYSTEM PRESSURE SENSOR

Refer to [EC-269. "Component Inspection"](#).

Is the inspection result normal?

YES >> GO TO 17.

NO >> Replace EVAP control system pressure sensor.

17.CHECK EVAP/ORVR LINE

Check EVAP/ORVR line between EVAP canister and fuel tank for clogging, kink, looseness and improper connection. For location, refer to [EC-407. "Description"](#).

Is the inspection result normal?

YES >> GO TO 18.

NO >> Repair or replace hoses and tubes.

18.CHECK RECIRCULATION LINE

Check recirculation line between fuel filler tube and fuel tank for clogging, kink, cracks, looseness and improper connection.

Is the inspection result normal?

YES >> GO TO 19.

NO >> Repair or replace hose, tube or fuel filler tube.

19.CHECK REFUELING EVAP VAPOR CUT VALVE

Refer to [EC-410. "Component Inspection \(Refueling EVAP vapor cut valve\)"](#).

Is the inspection result normal?

YES >> GO TO 20.

NO >> Replace refueling EVAP vapor cut valve with fuel tank.

20.CHECK INTERMITTENT INCIDENT

Refer to [GI-34. "Intermittent Incident"](#).

>> INSPECTION END

Component Inspection (Fuel filler cap)

INFOID:000000004833392

1.CHECK FUEL FILLER CAP

1. Turn ignition switch OFF.
2. Remove fuel filler cap.
3. Wipe clean valve housing.

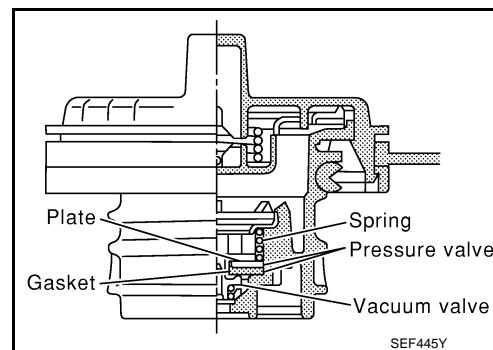

P0455 EVAP CONTROL SYSTEM

[MR18DE]

< DTC/CIRCUIT DIAGNOSIS >

4. Install fuel filler cap adapter (commercial service tool) to fuel filler cap.
5. Check valve opening pressure and vacuum.

Pressure: 15.3 - 20.0 kPa (0.156 - 0.204 kg/cm², 2.22 - 2.90 psi)

Vacuum: -6.0 to -3.3 kPa (-0.061 to -0.034 kg/cm², -0.87 to -0.48 psi)

Is the inspection result normal?

YES >> INSPECTION END

NO >> GO TO 2.

2. REPLACE FUEL FILLER CAP

Replace fuel filler cap.

CAUTION:

Use only a genuine fuel filler cap as a replacement. If an incorrect fuel filler cap is used, the MIL may illuminate.

>> INSPECTION END

Component Inspection (Drain filter)

INFOID:000000004833393

1. CHECK DRAIN FILTER

1. Check visually for insect nests in the drain filter air inlet.
2. Check visually for cracks or flaws in the appearance.
3. Check visually for cracks or flaws in the hose.
4. Blow air into port A and check that it flows freely out of port B.
5. Block port B.
6. Blow air into port A and check that there is no leakage.

Is the inspection result normal?

YES >> INSPECTION END

NO >> Replace drain filter.

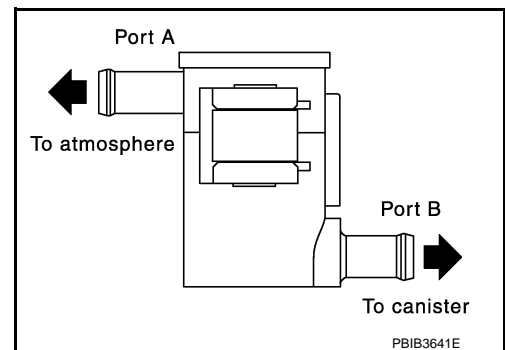
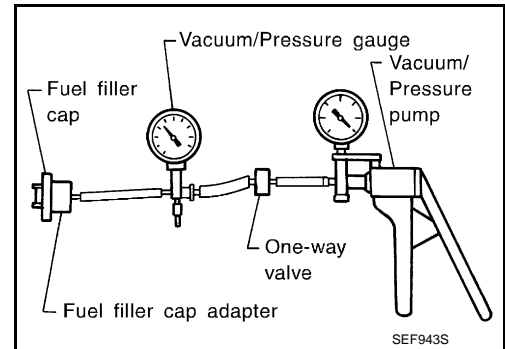

P0456 EVAP CONTROL SYSTEM

< DTC/CIRCUIT DIAGNOSIS >

[MR18DE]

P0456 EVAP CONTROL SYSTEM

DTC Logic

INFOID:000000004833394

DTC DETECTION LOGIC

This diagnosis detects very small leaks in the EVAP line between fuel tank and EVAP canister purge volume control solenoid valve, using the intake manifold vacuum in the same way as conventional EVAP small leak diagnosis.

If ECM judges a leak which corresponds to a very small leak, the very small leak P0456 will be detected.

If ECM judges a leak equivalent to a small leak, EVAP small leak P0442 will be detected.

If ECM judges there are no leaks, the diagnosis will be OK.

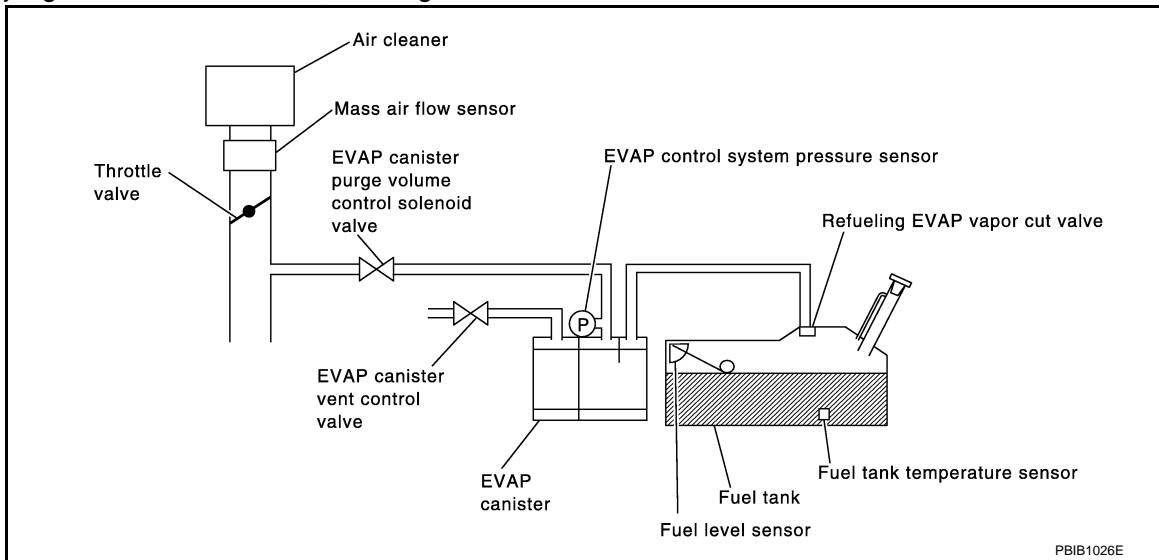

DTC No.	Trouble diagnosis name	DTC detecting condition	Possible cause
P0456	Evaporative emission control system very small leak (negative pressure check)	<ul style="list-style-type: none"> • EVAP system has a very small leak. • EVAP system does not operate properly. 	<ul style="list-style-type: none"> • Incorrect fuel tank vacuum relief valve • Incorrect fuel filler cap used • Fuel filler cap remains open or fails to close. • Foreign matter caught in fuel filler cap. • Leak is in line between intake manifold and EVAP canister purge volume control solenoid valve. • Foreign matter caught in EVAP canister vent control valve. • EVAP canister or fuel tank leaks • EVAP purge line (pipe and rubber tube) leaks • EVAP purge line rubber tube bent • Loose or disconnected rubber tube • EVAP canister vent control valve and the circuit • EVAP canister purge volume control solenoid valve and the circuit • Fuel tank temperature sensor • O-ring of EVAP canister vent control valve is missing or damaged • EVAP canister is saturated with water • EVAP control system pressure sensor • Refueling EVAP vapor cut valve • ORVR system leaks • Fuel level sensor and the circuit • Foreign matter caught in EVAP canister purge volume control solenoid valve • Drain filter

CAUTION:

- Use only a genuine NISSAN fuel filler cap as a replacement. If an incorrect fuel filler cap is used, the MIL may come on.
- If the fuel filler cap is not tightened properly, the MIL may come on.

P0456 EVAP CONTROL SYSTEM

[MR18DE]

< DTC/CIRCUIT DIAGNOSIS >

- Use only a genuine NISSAN rubber tube as a replacement.

DTC CONFIRMATION PROCEDURE

1. INSPECTION START

Do you have CONSULT-III?

Do you have CONSULT-III?

YES >> GO TO 2.

NO >> GO TO 4.

2. PRECONDITIONING

If DTC Confirmation Procedure has been previously conducted, always turn ignition switch OFF and wait at least 10 seconds before conducting the next test.

NOTE:

- If DTC P0456 is displayed with P0442, first perform trouble diagnosis for DTC P0456.
- After repair, make sure that the hoses and clips are installed properly.
- Make sure that EVAP hoses are connected to EVAP canister purge volume control solenoid valve properly.

TESTING CONDITION:

- Open engine hood before conducting following procedure.
- If any of following conditions are met just before the DTC CONFIRMATION PROCEDURE, leave the vehicle for more than 1 hour.
 - Fuel filler cap is removed.
 - Fuel is refilled or drained.
 - EVAP component parts is/are removed.
- Before performing the following procedure, confirm that battery voltage is more than 11 V at idle.

>> GO TO 3.

3. PERFORM DTC CONFIRMATION PROCEDURE

Ⓜ With CONSULT-III

1. Turn ignition switch ON and select "DATA MONITOR" mode with CONSULT-III.

2. Make sure the following conditions are met.

FUEL LEVEL SE: 0.25 - 1.4 V

COOLAN TEMP/S: 0 - 32°C (32 - 90°F)

FUEL T/TMP SE: 0 - 35°C (32 - 95°F)

INT A/TEMP SE: More than 0°C (32°F)

If NG, turn ignition switch OFF and leave the vehicle in a cool place (soak the vehicle) or refilling/draining fuel until the output voltage condition of the "FUEL LEVEL SE" meets within the range above and leave the vehicle for more than 1 hour. Then start from step 1.

3. Turn ignition switch OFF and wait at least 10 seconds.

4. Turn ignition switch ON.

5. Select "EVAP V/S LEAK P0456/P1456" of "EVAPORATIVE SYSTEM" in "DTC WORK SUPPORT" mode with CONSULT-III.

Follow the instruction displayed.

NOTE:

If the engine speed cannot be maintained within the range displayed on CONSULT-III screen, go to [EC-12, "BASIC INSPECTION : Special Repair Requirement"](#).

Which is displayed on CONSULT-III?

OK >> INSPECTION END

NG >> Go to [EC-289, "Diagnosis Procedure"](#).

4. PERFORM COMPONENT FUNCTION CHECK

Perform component function check. Refer to [EC-289, "Component Function Check"](#).

NOTE:

Use component function check to check the overall function of the EVAP very small leak function. During this check, a 1st trip DTC might not be confirmed.

Is the inspection result normal?

YES >> INSPECTION END

P0456 EVAP CONTROL SYSTEM

[MR18DE]

< DTC/CIRCUIT DIAGNOSIS >

NO >> Go to [EC-289. "Diagnosis Procedure"](#).

Component Function Check

INFOID:000000004833395

1. PERFORM COMPONENT FUNCTION CHECK

 With GST

CAUTION:

- Do not use compressed air, doing so may damage the EVAP system.
- Do not start engine.

• Do not exceeded 4.12 kPa (0.042 kg/cm², 0.6 psi).

1. Attach the EVAP service port adapter securely to the EVAP service port.
2. Set the pressure pump and a hose.
3. Also set a vacuum gauge via 3-way connector and a hose.
4. Turn ignition switch ON.
5. Connect GST and select Service \$08.
6. Using Service \$08 control the EVAP canister vent control valve (close).
7. Apply pressure and make sure the following conditions are satisfied.

Pressure to be applied: 2.7 kPa (0.028 kg/cm², 0.39 psi)

Time to be waited after the pressure drawn in to the EVAP system and the pressure to be dropped: 60 seconds and the pressure should not be dropped more than 0.4 kPa (0.004 kg/cm², 0.06 psi).

Is the inspection result normal?

YES >> GO TO 2.

NO >> Go to [EC-289. "Diagnosis Procedure"](#).

2. RELEASE PRESSURE

1. Disconnect GST.
2. Start engine and warm it up to normal operating temperature.
3. Turn ignition switch OFF and wait at least 10 seconds.
4. Restart engine and let it idle for 90 seconds.
5. Keep engine speed at 2,000 rpm for 30 seconds.
6. Turn ignition switch OFF.

NOTE:

For more information, refer to GST Instruction Manual.

>> INSPECTION END

Diagnosis Procedure

INFOID:000000004833396

1. CHECK FUEL FILLER CAP DESIGN

1. Turn ignition switch OFF.
2. Check for genuine NISSAN fuel filler cap design.

Is the inspection result normal?

YES >> GO TO 2.

NO >> Replace with genuine NISSAN fuel filler cap.

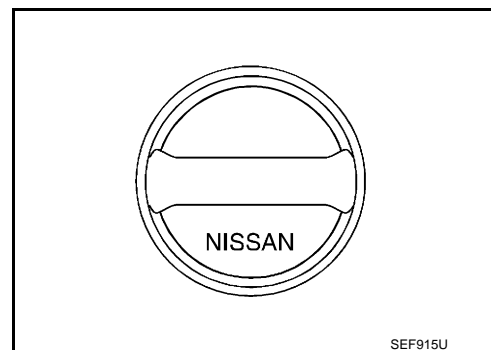
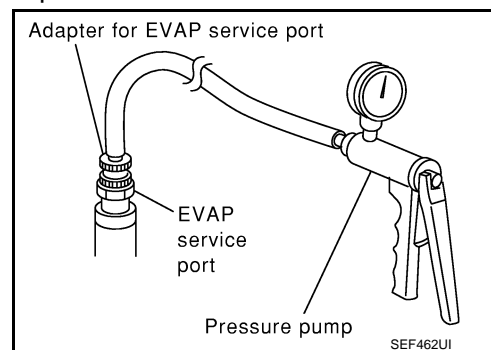

2. CHECK FUEL FILLER CAP INSTALLATION

Check that the cap is tightened properly by rotating the cap clockwise.

P0456 EVAP CONTROL SYSTEM

[MR18DE]

< DTC/CIRCUIT DIAGNOSIS >

Is the inspection result normal?

YES >> GO TO 3.

NO >> Open fuel filler cap, then clean cap and fuel filler neck threads using air blower. Then retighten until ratcheting sound is heard.

3.CHECK FUEL FILLER CAP FUNCTION

Check for air releasing sound while opening the fuel filler cap.

Is the inspection result normal?

YES >> GO TO 5.

NO >> GO TO 4.

4.CHECK FUEL TANK VACUUM RELIEF VALVE

Refer to [EC-292, "Component Inspection \(Fuel filler cap\)"](#).

Is the inspection result normal?

YES >> GO TO 5.

NO >> Replace fuel filler cap with a genuine one.

5.CHECK FOR EVAP LEAK

Refer to [EC-473, "Inspection"](#).

Is there any leak in EVAP line?

YES >> Repair or replace.

NO >> GO TO 6.

6.CHECK DRAIN FILTER

Refer to [EC-293, "Component Inspection \(Drain filter\)"](#).

Is the inspection result normal?

YES >> GO TO 7.

NO >> Replace drain filter.

7.CHECK EVAP CANISTER VENT CONTROL VALVE

Check the following.

- EVAP canister vent control valve is installed properly.

Refer to [EC-475, "Exploded View"](#).

- EVAP canister vent control valve.

Refer to [EC-261, "Component Inspection"](#).

Is the inspection result normal?

YES >> GO TO 8.

NO >> Repair or replace EVAP canister vent control valve and O-ring.

8.CHECK IF EVAP CANISTER IS SATURATED WITH WATER

1. Remove EVAP canister with EVAP canister vent control valve and EVAP control system pressure sensor attached.

2. Check if water will drain from the EVAP canister.

Does water drain from EVAP canister?

YES >> GO TO 9.

NO-1 >> With CONSULT-III: GO TO 11.

NO-2 >> Without CONSULT-III: GO TO 12.

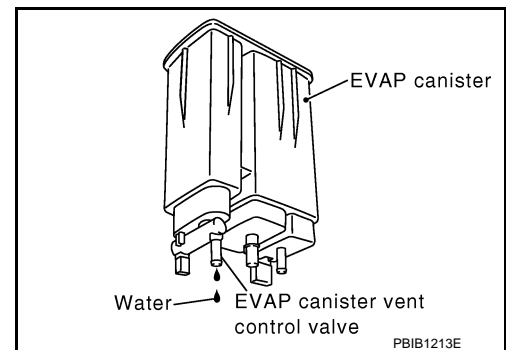

9.CHECK EVAP CANISTER

Weigh the EVAP canister with the EVAP canister vent control valve and EVAP control system pressure sensor attached.

The weight should be less than 1.9 kg (4.2 lb).

P0456 EVAP CONTROL SYSTEM

[MR18DE]

< DTC/CIRCUIT DIAGNOSIS >

Is the inspection result normal?

- YES-1 >> With CONSULT-III: GO TO 11.
- YES-2 >> Without CONSULT-III: GO TO 12.
- NO >> GO TO 10.

10. DETECT MALFUNCTIONING PART

Check the following.

- EVAP canister for damage
- EVAP hose between EVAP canister and vehicle frame for clogging or poor connection

>> Repair hose or replace EVAP canister.

11. CHECK EVAP CANISTER PURGE VOLUME CONTROL SOLENOID VALVE OPERATION

 **With CONSULT-III**

1. Disconnect vacuum hose to EVAP canister purge volume control solenoid valve at EVAP service port.
2. Start engine.
3. Perform "PURG VOL CONT/V" in "ACTIVE TEST" mode.
4. Touch "Qu" on CONSULT-III screen to increase "PURG VOL CONT/V" opening to 100%.
5. Check vacuum hose for vacuum.

Vacuum should exist.

Is the inspection result normal?

- YES >> GO TO 14.
- NO >> GO TO 13.

12. CHECK EVAP CANISTER PURGE VOLUME CONTROL SOLENOID VALVE OPERATION

 **Without CONSULT-III**

1. Start engine and warm it up to normal operating temperature.
2. Stop engine.
3. Disconnect vacuum hose to EVAP canister purge volume control solenoid valve at EVAP service port.
4. Start engine and let it idle for at least 80 seconds.
5. Check vacuum hose for vacuum when revving engine up to 2,000 rpm.

Vacuum should exist.

Is the inspection result normal?

- YES >> GO TO 15.
- NO >> GO TO 13.

13. CHECK VACUUM HOSE

Check vacuum hoses for clogging or disconnection. Refer to [EC-68, "System Description"](#).

Is the inspection result normal?

- YES >> GO TO 14.
- NO >> Repair or reconnect the hose.

14. CHECK EVAP CANISTER PURGE VOLUME CONTROL SOLENOID VALVE

Refer to [EC-252, "Diagnosis Procedure"](#).

Is the inspection result normal?

- YES >> GO TO 15.
- NO >> Replace EVAP canister purge volume control solenoid valve.

15. CHECK FUEL TANK TEMPERATURE SENSOR

Refer to [EC-210, "Component Inspection"](#).

Is the inspection result normal?

- YES >> GO TO 16.
- NO >> Replace fuel level sensor unit.

16. CHECK EVAP CONTROL SYSTEM PRESSURE SENSOR

P0456 EVAP CONTROL SYSTEM

[MR18DE]

< DTC/CIRCUIT DIAGNOSIS >

Refer to [EC-269, "Component Inspection"](#).

Is the inspection result normal?

YES >> GO TO 17.

NO >> Replace EVAP control system pressure sensor.

17.CHECK EVAP PURGE LINE

Check EVAP purge line (pipe, rubber tube, fuel tank and EVAP canister) for cracks or improper connection.

Refer to [EC-68, "System Description"](#).

Is the inspection result normal?

YES >> GO TO 18.

NO >> Repair or reconnect the hose.

18.CLEAN EVAP PURGE LINE

Clean EVAP purge line (pipe and rubber tube) using air blower.

>> GO TO 19.

19.CHECK EVAP/ORVR LINE

Check EVAP/ORVR line between EVAP canister and fuel tank for clogging, kink, looseness and improper connection. For location, refer to [EC-407, "Description"](#).

Is the inspection result normal?

YES >> GO TO 20.

NO >> Repair or replace hoses and tubes.

20.CHECK RECIRCULATION LINE

Check recirculation line between fuel filler tube and fuel tank for clogging, kink, cracks, looseness and improper connection.

Is the inspection result normal?

YES >> GO TO 21.

NO >> Repair or replace hose, tube or fuel filler tube.

21.CHECK REFUELING EVAP VAPOR CUT VALVE

Refer to [EC-410, "Component Inspection \(Refueling EVAP vapor cut valve\)"](#).

Is the inspection result normal?

YES >> GO TO 22.

NO >> Replace refueling EVAP vapor cut valve with fuel tank.

22.CHECK FUEL LEVEL SENSOR

Refer to [FL-8, "Inspection"](#).

Is the inspection result normal?

YES >> GO TO 23.

NO >> Replace fuel level sensor unit.

23.CHECK INTERMITTENT INCIDENT

Refer to [GI-34, "Intermittent Incident"](#).

>> INSPECTION END

Component Inspection (Fuel filler cap)

INFOID:000000004833397

1.CHECK FUEL FILLER CAP

1. Turn ignition switch OFF.
2. Remove fuel filler cap.

P0456 EVAP CONTROL SYSTEM

[MR18DE]

< DTC/CIRCUIT DIAGNOSIS >

3. Wipe clean valve housing.

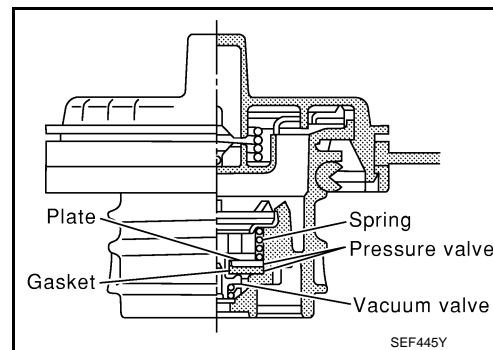

4. Install fuel filler cap adapter (commercial service tool) to fuel filler cap.

5. Check valve opening pressure and vacuum.

Pressure: 15.3 - 20.0 kPa (0.156 - 0.204 kg/cm², 2.22 - 2.90 psi)

Vacuum: -6.0 to -3.3 kPa (-0.061 to -0.034 kg/cm², -0.87 to -0.48 psi)

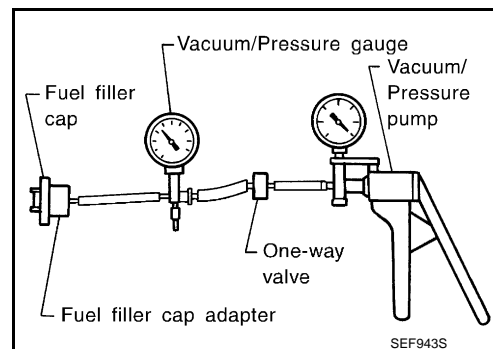

Is the inspection result normal?

YES >> INSPECTION END

NO >> GO TO 2.

2. REPLACE FUEL FILLER CAP

Replace fuel filler cap.

CAUTION:

Use only a genuine fuel filler cap as a replacement. If an incorrect fuel filler cap is used, the MIL may illuminate.

>> INSPECTION END

Component Inspection (Drain filter)

INFOID:000000004833398

1. CHECK DRAIN FILTER

1. Check visually for insect nests in the drain filter air inlet.
2. Check visually for cracks or flaws in the appearance.
3. Check visually for cracks or flaws in the hose.
4. Blow air into port A and check that it flows freely out of port B.
5. Block port B.
6. Blow air into port A and check that there is no leakage.

Is the inspection result normal?

YES >> INSPECTION END

NO >> Replace drain filter.

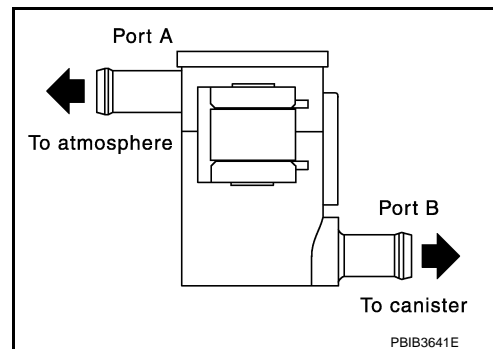

P0460 FUEL LEVEL SENSOR

[MR18DE]

< DTC/CIRCUIT DIAGNOSIS >

P0460 FUEL LEVEL SENSOR

Description

INFOID:000000004833399

The fuel level sensor is mounted in the fuel level sensor unit. The sensor detects a fuel level in the fuel tank and transmits a signal to the combination meter. The combination meter sends the fuel level sensor signal to the ECM via the CAN communication line. It consists of two parts, one is mechanical float and the other is variable resistor. Fuel level sensor output voltage changes depending on the movement of the fuel mechanical float.

DTC Logic

INFOID:000000004833400

DTC DETECTION LOGIC

NOTE:

- If DTC P0460 is displayed with DTC UXXXX, first perform the trouble diagnosis for DTC UXXXX.
- If DTC P0460 is displayed with DTC P0607, first perform the trouble diagnosis for DTC P0607. Refer to [EC-307, "DTC Logic"](#).

When the vehicle is parked, naturally the fuel level in the fuel tank is stable. It means that output signal of the fuel level sensor does not change. If ECM senses sloshing signal from the sensor, fuel level sensor malfunction is detected.

DTC No.	Trouble diagnosis name	DTC detecting condition	Possible cause
P0460	Fuel level sensor circuit noise	Even though the vehicle is parked, a signal being varied is sent from the fuel level sensor to ECM.	<ul style="list-style-type: none">• Harness or connectors (The CAN communication line is open or shorted)• Harness or connectors (The sensor circuit is open or shorted)• Combination meter• Fuel level sensor

DTC CONFIRMATION PROCEDURE

1. PRECONDITIONING

If DTC Confirmation Procedure has been previously conducted, always turn ignition switch OFF and wait at least 10 seconds before conducting the next test.

>> GO TO 2.

2. PERFORM DTC CONFIRMATION PROCEDURE

1. Start engine and wait maximum of 2 consecutive minutes.
2. Check 1st trip DTC.

Is 1st trip DTC detected?

YES >> Go to [EC-294, "Diagnosis Procedure"](#).

NO >> INSPECTION END

Diagnosis Procedure

INFOID:000000004833401

1. CHECK COMBINATION METER FUNCTION

Refer to [MWI-30, "CONSULT-III Function \(METER/M&A\)"](#).

Is the inspection result normal?

YES >> GO TO 2.

NO >> Refer to [MWI-42, "Component Function Check"](#)

2. CHECK INTERMITTENT INCIDENT

Refer to [GI-34, "Intermittent Incident"](#).

>> INSPECTION END

P0461 FUEL LEVEL SENSOR

< DTC/CIRCUIT DIAGNOSIS >

[MR18DE]

P0461 FUEL LEVEL SENSOR

Description

INFOID:000000004833402

The fuel level sensor is mounted in the fuel level sensor unit. The sensor detects a fuel level in the fuel tank and transmits a signal to the combination meter. The combination meter sends the fuel level sensor signal to the ECM via the CAN communication line. It consists of two parts, one is mechanical float and the other is variable resistor. Fuel level sensor output voltage changes depending on the movement of the fuel mechanical float.

DTC Logic

INFOID:000000004833403

DTC DETECTION LOGIC

NOTE:

- If DTC P0461 is displayed with DTC UXXXX, first perform the trouble diagnosis for DTC UXXXX.
- If DTC P0461 is displayed with DTC P0607, first perform the trouble diagnosis for DTC P0607. Refer to [EC-307, "DTC Logic"](#).

Driving long distances naturally affect fuel gauge level.

This diagnosis detects the fuel gauge malfunction of the gauge not moving even after a long distance has been driven.

DTC No.	Trouble diagnosis name	DTC detecting condition	Possible cause
P0461	Fuel level sensor circuit range/performance	The output signal of the fuel level sensor does not change within the specified range even though the vehicle has been driven a long distance.	<ul style="list-style-type: none">• Harness or connectors (The CAN communication line is open or shorted)• Harness or connectors (The sensor circuit is open or shorted)• Combination meter• Fuel level sensor

DTC CONFIRMATION PROCEDURE

1. PERFORM COMPONENT FUNCTION CHECK

Perform component function check. Refer to [EC-295, "Component Function Check"](#).

Use component function check to check the overall function of the fuel level sensor function. During this check, a 1st trip DTC might not be confirmed.

Is the inspection result normal?

YES >> INSPECTION END

NO >> Go to [EC-296, "Diagnosis Procedure"](#).

Component Function Check

INFOID:000000004833404

1. PRECONDITIONING

WARNING:

When performing following procedure, be sure to observe the handling of the fuel. Refer to [FL-2, "General Precautions"](#).

TESTING CONDITION:

Before starting component function check, preparation of draining fuel and refilling fuel is required.

Do you have CONSULT-III?

YES >> GO TO 2.

NO >> GO TO 3.

2. PERFORM COMPONENT FUNCTION CHECK

With CONSULT-III

NOTE:

Start from step 10, if it is possible to confirm that the fuel cannot be drained by 30 ℓ (7-7/8 US gal, 6-5/8 Imp gal) in advance.

1. Prepare a fuel container and a spare hose.

P0461 FUEL LEVEL SENSOR

[MR18DE]

< DTC/CIRCUIT DIAGNOSIS >

2. Release fuel pressure from fuel line, refer to [EC-471, "Inspection"](#).
3. Remove the fuel feed hose on the fuel level sensor unit.
4. Connect a spare fuel hose where the fuel feed hose was removed.
5. Turn ignition switch OFF and wait at least 10 seconds then turn ON.
6. Select "FUEL LEVEL SE" in "DATA MONITOR" mode with CONSULT-III.
7. Check "FUEL LEVEL SE" output voltage and note it.
8. Select "FUEL PUMP RELAY" in "ACTIVE TEST" mode with CONSULT-III.
9. Touch "ON" and drain fuel approximately 30 ℓ (7-7/8 US gal, 6-5/8 Imp gal) and stop it.
10. Check "FUEL LEVEL SE" output voltage and note it.
11. Fill fuel into the fuel tank for 30 ℓ (7-7/8 US gal, 6-5/8 Imp gal).
12. Check "FUEL LEVEL SE" output voltage and note it.
13. Confirm whether the voltage changes more than 0.03 V during step 7 to 10 and 10 to 12.

Is the inspection result normal?

YES >> INSPECTION END

NO >> Go to [EC-296, "Diagnosis Procedure"](#).

3.PERFORM COMPONENT FUNCTION CHECK

⊗ Without CONSULT-III

NOTE:

Start from step 8, if it is possible to confirm that the fuel cannot be drained by 30 ℓ (7-7/8 US gal, 6-5/8 Imp gal) in advance.

1. Prepare a fuel container and a spare hose.
2. Release fuel pressure from fuel line. Refer to [EC-471, "Inspection"](#).
3. Remove the fuel feed hose on the fuel level sensor unit.
4. Connect a spare fuel hose where the fuel feed hose was removed.
5. Turn ignition switch ON.
6. Drain fuel by 30 ℓ (7-7/8 US gal, 6-5/8 Imp gal) from the fuel tank using proper equipment.
7. Confirm that the fuel gauge indication varies.
8. Fill fuel into the fuel tank for 30 ℓ (7-7/8 US gal, 6-5/8 Imp gal).
9. Confirm that the fuel gauge indication varies.

Is the inspection result normal?

YES >> INSPECTION END

NO >> Go to [EC-296, "Diagnosis Procedure"](#).

Diagnosis Procedure

INFOID:000000004833405

1.CHECK COMBINATION METER FUNCTION

Refer to [MWI-30, "CONSULT-III Function \(METER/M&A\)"](#).

Is the inspection result normal?

YES >> GO TO 2.

NO >> Refer to [MWI-42, "Component Function Check"](#)

2.CHECK INTERMITTENT INCIDENT

Refer to [GI-34, "Intermittent Incident"](#).

>> INSPECTION END

P0462, P0463 FUEL LEVEL SENSOR

< DTC/CIRCUIT DIAGNOSIS >

[MR18DE]

P0462, P0463 FUEL LEVEL SENSOR

Description

INFOID:000000004833406

The fuel level sensor is mounted in the fuel level sensor unit. The sensor detects a fuel level in the fuel tank and transmits a signal to the combination meter. The combination meter sends the fuel level sensor signal to the ECM via the CAN communication line. It consists of two parts, one is mechanical float and the other is variable resistor. Fuel level sensor output voltage changes depending on the movement of the fuel mechanical float.

DTC Logic

INFOID:000000004833407

DTC DETECTION LOGIC

NOTE:

- If DTC P0462 or P0463 is displayed with DTC UXXXX, first perform the trouble diagnosis for DTC UXXXX.
- If DTC P0462 or P0463 is displayed with DTC P0607, first perform the trouble diagnosis for DTC P0607. Refer to [EC-307, "DTC Logic"](#).

This diagnosis indicates the former, to detect open or short circuit malfunction.

DTC No.	Trouble diagnosis name	DTC detecting condition	Possible cause
P0462	Fuel level sensor circuit low input	An excessively low voltage from the sensor is sent to ECM.	<ul style="list-style-type: none">• Harness or connectors (The CAN communication line is open or shorted)
P0463	Fuel level sensor circuit high input	An excessively high voltage from the sensor is sent to ECM.	<ul style="list-style-type: none">• Harness or connectors (The sensor circuit is open or shorted)• Combination meter• Fuel level sensor

DTC CONFIRMATION PROCEDURE

1. PRECONDITIONING

If DTC Confirmation Procedure has been previously conducted, always turn ignition switch OFF and wait at least 10 seconds before conducting the next test.

TESTING CONDITION:

Before performing the following procedure, confirm that battery voltage is between 11 V and 16 V at ignition switch ON.

>> GO TO 2.

2. PERFORM DTC CONFIRMATION PROCEDURE

1. Turn ignition switch ON and wait at least 5 seconds.
2. Check 1st trip DTC.

Is 1st trip DTC detected?

- YES >> Go to [EC-297, "Diagnosis Procedure"](#).
NO >> INSPECTION END

Diagnosis Procedure

INFOID:000000004833408

1. CHECK COMBINATION METER FUNCTION

Refer to [MWI-30, "CONSULT-III Function \(METER/M&A\)"](#).

Is the inspection result normal?

- YES >> GO TO 2.
NO >> Refer to [MWI-42, "Component Function Check"](#)

2. CHECK INTERMITTENT INCIDENT

Refer to [GI-34, "Intermittent Incident"](#).

P0462, P0463 FUEL LEVEL SENSOR

< DTC/CIRCUIT DIAGNOSIS >

[MR18DE]

>> INSPECTION END

P0500 VSS

Description

INFOID:000000004833409

The vehicle speed signal is sent to the combination meter from the “ABS actuator and electric unit (control unit)” via the CAN communication line. The combination meter then sends a signal to the ECM via the CAN communication line.

DTC Logic

INFOID:000000004833410

DTC DETECTION LOGIC

NOTE:

- If DTC P0500 is displayed with DTC UXXXX, first perform the trouble diagnosis for DTC UXXXX.
- If DTC P0500 is displayed with DTC P0607, first perform the trouble diagnosis for DTC P0607. Refer to [EC-307, "DTC Logic"](#).

DTC No.	Trouble diagnosis name	DTC detecting condition	Possible cause
P0500	Vehicle speed sensor	The vehicle speed signal sent to ECM is almost 0 km/h (0 MPH) even when vehicle is being driven.	<ul style="list-style-type: none"> • Harness or connectors (The CAN communication line is open or shorted) • Harness or connectors (The vehicle speed signal circuit is open or shorted) • Wheel sensor • Combination meter • ABS actuator and electric unit (control unit)

DTC CONFIRMATION PROCEDURE

1.INSPECTION START

Do you have CONSULT-III?

Do you have CONSULT-III?

- YES >> GO TO 2.
- NO >> GO TO 5.

2.PRECONDITIONING

If DTC Confirmation Procedure has been previously conducted, always turn ignition switch OFF and wait at least 10 seconds before conducting the next test.

>> GO TO 3.

3.CHECK VEHICLE SPEED SIGNAL

NOTE:

This procedure may be conducted with the drive wheels lifted in the shop or by driving the vehicle. If a road test is expected to be easier, it is unnecessary to lift the vehicle.

 With CONSULT-III

1. Start engine.
2. Read “VHCL SPEED SE” in “DATA MONITOR” mode with CONSULT-III. The vehicle speed on CONSULT-III should exceed 10 km/h (6 mph) when rotating wheels with suitable gear position.

Is the inspection result normal?

- YES >> GO TO 4.
- NO >> Go to [EC-300, "Diagnosis Procedure"](#).

4.PERFORM DTC CONFIRMATION PROCEDURE

1. Select “DATA MONITOR” mode with CONSULT-III.
2. Warm engine up to normal operating temperature.
3. Maintain the following conditions for at least 50 consecutive seconds.

CAUTION:

Always drive vehicle at a safe speed.

< DTC/CIRCUIT DIAGNOSIS >

ENG SPEED	CVT: 1,600 - 6,000 rpm M/T: 2,200 - 6,000 rpm
COOLAN TEMP/S	More than 70°C (158°F)
B/FUEL SCHDL	CVT: 5.5 - 31.8 msec M/T: 4.0 - 31.8 msec
Selector lever	Except P or N position (CVT) Except Neutral position (M/T)
PW/ST SIGNAL	OFF

4. Check 1st trip DTC.

Is 1st trip DTC detected?

- YES >> Go to [EC-300, "Diagnosis Procedure"](#).
- NO >> INSPECTION END

5. PERFORM COMPONENT FUNCTION CHECK

Perform component function check. Refer to [EC-300, "Component Function Check"](#).

Use component function check to check the overall function of the vehicle speed signal circuit. During this check, a 1st trip DTC might not be confirmed.

Is the inspection result normal?

- YES >> INSPECTION END
- NO >> Go to [EC-300, "Diagnosis Procedure"](#).

Component Function Check

INFOID:000000004833411

1. PERFORM COMPONENT FUNCTION CHECK

 **With GST**

1. Lift up drive wheels.
2. Start engine.
3. Read vehicle speed signal in Service \$01 with GST.
The vehicle speed signal on GST should be able to exceed 10 km/h (6 MPH) when rotating wheels with suitable gear position.

Is the inspection result normal?

- YES >> INSPECTION END
- NO >> Go to [EC-300, "Diagnosis Procedure"](#).

Diagnosis Procedure

INFOID:000000004833412

1. CHECK DTC WITH "ABS ACTUATOR AND ELECTRIC UNIT (CONTROL UNIT)"

Refer to [BRC-22, "CONSULT-III Function"](#).

Is the inspection result normal?

- YES >> GO TO 2.
- NO >> Repair or replace.

2. CHECK COMBINATION METER

Refer to [MWI-30, "CONSULT-III Function \(METER/M&A\)"](#).

>> INSPECTION END

P0506 ISC SYSTEM

Description

INFOID:000000004833413

The ECM controls the engine idle speed to a specified level through the fine adjustment of the air, which is let into the intake manifold, by operating the electric throttle control actuator. The operating of the throttle valve is varied to allow for optimum control of the engine idling speed. The crankshaft position sensor (POS) detects the actual engine speed and sends a signal to the ECM.

The ECM controls the electric throttle control actuator so that the engine speed coincides with the target value memorized in the ECM. The target engine speed is the lowest speed at which the engine can operate steadily. The optimum value stored in the ECM is determined by taking into consideration various engine conditions, such as during warming up, deceleration, and engine load (air conditioner, power steering and cooling fan operation, etc.).

DTC Logic

INFOID:000000004833414

DTC DETECTION LOGIC

NOTE:

If DTC P0506 is displayed with other DTC, first perform the trouble diagnosis for the other DTC.

DTC No.	Trouble diagnosis name	DTC detecting condition	Possible cause
P0506	Idle speed control system RPM lower than expected	The idle speed is less than the target idle speed by 100 rpm or more.	<ul style="list-style-type: none"> • Electric throttle control actuator • Intake air leak

DTC CONFIRMATION PROCEDURE

1. PRECONDITIONING

If DTC Confirmation Procedure has been previously conducted, always turn ignition switch OFF and wait at least 10 seconds before conducting the next test.

If the target idle speed is out of the specified value, perform **EC-17, "IDLE AIR VOLUME LEARNING : Special Repair Requirement"**, before conducting DTC Confirmation Procedure.

TESTING CONDITION:

- Before performing the following procedure, confirm that battery voltage is more than 11 V at idle.
- Always perform the test at a temperature above -10°C(14°F).

>> GO TO 2.

2. PERFORM DTC CONFIRMATION PROCEDURE

1. Start engine and warm it up to normal operating temperature.
2. Turn ignition switch OFF and wait at least 10 seconds.
3. Start engine and run it for at least 1 minute at idle speed.
4. Check 1st trip DTC.

Is 1st trip DTC detected?

- YES >> Go to **EC-301, "Diagnosis Procedure"**.
- NO >> INSPECTION END

Diagnosis Procedure

INFOID:000000004833415

1. CHECK INTAKE AIR LEAK

1. Start engine and let it idle.
2. Listen for an intake air leak after the mass air flow sensor.

Is intake air leak detected?

- YES >> Discover air leak location and repair.
- NO >> GO TO 2.

2. REPLACE ECM

1. Stop engine.
2. Replace ECM.

P0506 ISC SYSTEM

< DTC/CIRCUIT DIAGNOSIS >

[MR18DE]

3. Perform [EC-15. "ADDITIONAL SERVICE WHEN REPLACING CONTROL UNIT : Special Repair Requirement"](#).

>> INSPECTION END

P0507 ISC SYSTEM

Description

INFOID:000000004833416

The ECM controls the engine idle speed to a specified level through the fine adjustment of the air, which is let into the intake manifold, by operating the electric throttle control actuator. The operating of the throttle valve is varied to allow for optimum control of the engine idling speed. The crankshaft position sensor (POS) detects the actual engine speed and sends a signal to the ECM.

The ECM controls the electric throttle control actuator so that the engine speed coincides with the target value memorized in the ECM. The target engine speed is the lowest speed at which the engine can operate steadily. The optimum value stored in the ECM is determined by taking into consideration various engine conditions, such as during warming up, deceleration, and engine load (air conditioner, power steering and cooling fan operation, etc.).

DTC Logic

INFOID:000000004833417

DTC DETECTION LOGIC

NOTE:

If DTC P0507 is displayed with other DTC, first perform the trouble diagnosis for the other DTC.

DTC No.	Trouble diagnosis name	DTC detecting condition	Possible cause
P0507	Idle speed control system RPM higher than expected	The idle speed is more than the target idle speed by 200 rpm or more.	<ul style="list-style-type: none"> • Electric throttle control actuator • Intake air leak • PCV system

DTC CONFIRMATION PROCEDURE

1. PRECONDITIONING

If DTC Confirmation Procedure has been previously conducted, always turn ignition switch OFF and wait at least 10 seconds before conducting the next test.

If the target idle speed is out of the specified value, perform [EC-17, "IDLE AIR VOLUME LEARNING : Special Repair Requirement"](#), before conducting DTC Confirmation Procedure.

TESTING CONDITION:

- Before performing the following procedure, confirm that battery voltage is more than 11 V at idle.
- Always perform the test at a temperature above -10°C(14°F).

>> GO TO 2.

2. PERFORM DTC CONFIRMATION PROCEDURE

1. Start engine and warm it up to normal operating temperature.
2. Turn ignition switch OFF and wait at least 10 seconds.
3. Start engine and run it for at least 1 minute at idle speed.
4. Check 1st trip DTC.

Is 1st trip DTC detected?

- YES >> Go to [EC-303, "Diagnosis Procedure"](#).
- NO >> INSPECTION END

Diagnosis Procedure

INFOID:000000004833418

1. CHECK PCV HOSE CONNECTION

Confirm that PCV hose is connected correctly.

Is the inspection result normal?

- YES >> GO TO 2.
- NO >> Repair or replace.

2. CHECK INTAKE AIR LEAK

1. Start engine and let it idle.
2. Listen for an intake air leak after the mass air flow sensor.

P0507 ISC SYSTEM

[MR18DE]

< DTC/CIRCUIT DIAGNOSIS >

Is intake air leak detected?

YES >> Discover air leak location and repair.

NO >> GO TO 3.

3.REPLACE ECM

1. Stop engine.
2. Replace ECM.
3. Perform [EC-15. "ADDITIONAL SERVICE WHEN REPLACING CONTROL UNIT : Special Repair Requirement"](#).

>> INSPECTION END

P0605 ECM

Description

INFOID:000000004833422

The ECM consists of a microcomputer and connectors for signal input and output and for power supply. The ECM controls the engine.

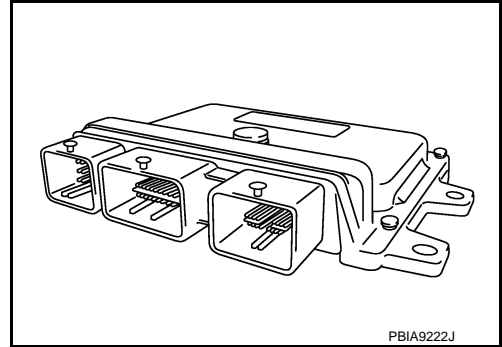

DTC Logic

INFOID:000000004833423

DTC DETECTION LOGIC

DTC No.	Trouble diagnosis name	DTC detecting condition		Possible cause
P0605	Engine control module	A)	ECM calculation function is malfunctioning.	• ECM
		B)	ECM EEPROM system is malfunctioning.	
		C)	ECM self shut-off function is malfunctioning.	

DTC CONFIRMATION PROCEDURE

1. PRECONDITIONING

If DTC Confirmation Procedure has been previously conducted, always turn ignition switch OFF and wait at least 10 seconds before conducting the next test.

>> GO TO 2.

2. PERFORM DTC CONFIRMATION PROCEDURE FOR MALFUNCTION A

- Turn ignition switch ON.
- Check 1st trip DTC.

Is 1st trip DTC detected?

- YES >> Go to [EC-306, "Diagnosis Procedure"](#).
- NO >> GO TO 3.

3. PERFORM DTC CONFIRMATION PROCEDURE FOR MALFUNCTION B

- Turn ignition switch ON and wait at least 1 second.
- Turn ignition switch OFF, wait at least 10 seconds and then turn ON.
- Check 1st trip DTC.

Is 1st trip DTC detected?

- YES >> Go to [EC-306, "Diagnosis Procedure"](#).
- NO >> GO TO 4.

4. PERFORM DTC CONFIRMATION PROCEDURE FOR MALFUNCTION C

- Turn ignition switch ON and wait at least 1 second.
- Turn ignition switch OFF, wait at least 10 seconds and then turn ON.
- Repeat step 2 for 32 times.
- Check 1st trip DTC.

Is 1st trip DTC detected?

- YES >> Go to [EC-306, "Diagnosis Procedure"](#).
- NO >> INSPECTION END

Diagnosis Procedure

INFOID:000000004833424

1.INSPECTION START

1. Turn ignition switch ON.
2. Erase 1st trip DTC. Refer to "How to Erase DTC and 1st Trip DTC" in [EC-85. "Diagnosis Description"](#).
3. Perform DTC CONFIRMATION PROCEDURE. Refer to [EC-305. "DTC Logic"](#).

Is the 1st trip DTC P0605 displayed again?

- YES >> GO TO 2.
- NO >> INSPECTION END

2.REPLACE ECM

1. Replace ECM.
2. Perform [EC-15. "ADDITIONAL SERVICE WHEN REPLACING CONTROL UNIT : Special Repair Requirement"](#).

>> INSPECTION END

P0607 ECM

Description

INFOID:000000004833425

CAN (Controller Area Network) is a serial communication line for real time application. It is an on-vehicle multiplex communication line with high data communication speed and excellent error detection ability. Many electronic control units are equipped onto a vehicle, and each control unit shares information and links with other control units during operation (not independent). In CAN communication, control units are connected with 2 communication lines (CAN H line, CAN L line) allowing a high rate of information transmission with less wiring. Each control unit transmits/receives data but selectively reads required data only.

DTC Logic

INFOID:000000004833426

DTC DETECTION LOGIC

DTC No.	Trouble diagnosis name	DTC detecting condition	Possible cause
P0607	CAN communication bus	When detecting error during the initial diagnosis of CAN controller of ECM.	<ul style="list-style-type: none"> ECM

DTC CONFIRMATION PROCEDURE

1.PERFORM DTC CONFIRMATION PROCEDURE

1. Turn ignition switch ON.
2. Check DTC.

Is DTC detected?

- YES >> Go to [EC-307. "Diagnosis Procedure"](#).
- NO >> INSPECTION END

Diagnosis Procedure

INFOID:000000004833427

1.INSPECTION START

1. Turn ignition switch ON.
2. Erase DTC. Refer to "How to Erase DTC and 1st Trip DTC" in [.EC-85. "Diagnosis Description"](#)
3. Perform DTC CONFIRMATION PROCEDURE. Refer to [EC-307. "DTC Logic"](#).
4. Check DTC.

Is the DTC P0607 displayed again?

- YES >> GO TO 2.
- NO >> INSPECTION END

2.REPLACE ECM

1. Replace ECM.
2. Perform [EC-15. "ADDITIONAL SERVICE WHEN REPLACING CONTROL UNIT : Special Repair Requirement"](#).

>> INSPECTION END

P0643 SENSOR POWER SUPPLY

< DTC/CIRCUIT DIAGNOSIS >

[MR18DE]

P0643 SENSOR POWER SUPPLY

DTC Logic

INFOID:000000004833428

DTC DETECTION LOGIC

DTC No.	Trouble diagnosis name	DTC detecting condition	Possible cause
P0643	Sensor power supply circuit short	ECM detects a voltage of power source for sensor is excessively low or high.	<ul style="list-style-type: none">• Harness or connectors (APP sensor 1 circuit is shorted.) (TP sensor circuit is shorted.) (Battery current sensor circuit is shorted.) (PSP sensor circuit is shorted.) [Camshaft position sensor (PHASE) circuit is shorted.]• Accelerator pedal position sensor• Throttle position sensor• Battery current sensor• Power steering pressure sensor• Camshaft position sensor (PHASE)

DTC CONFIRMATION PROCEDURE

1. PRECONDITIONING

If DTC Confirmation Procedure has been previously conducted, always turn ignition switch OFF and wait at least 10 seconds before conducting the next test.

TESTING CONDITION:

Before performing the following procedure, confirm that battery voltage is more than 8 V at idle.

>> GO TO 2.

2. PERFORM DTC CONFIRMATION PROCEDURE

1. Start engine and let it idle for 1 second.
2. Check DTC.

Is DTC detected?

- YES >> Go to [EC-308, "Diagnosis Procedure"](#).
NO >> INSPECTION END

Diagnosis Procedure

INFOID:000000004833430

1. CHECK GROUND CONNECTION

1. Turn ignition switch OFF.
2. Check ground connection E38. Refer to [GI-37, "Circuit Inspection"](#).

Is the inspection result normal?

- YES >> GO TO 2.
NO >> Repair or replace ground connection.

2. CHECK ACCELERATOR PEDAL POSITION SENSOR 1 POWER SUPPLY CIRCUIT

1. Disconnect accelerator pedal position (APP) sensor harness connector.
2. Turn ignition switch ON.
3. Check the voltage between APP sensor harness connector and ground.

APP sensor		Ground	Voltage
Connector	Terminal		
E110	4	Ground	Approx. 5 V

Is the inspection result normal?

- YES >> GO TO 7.
NO >> GO TO 3.

P0643 SENSOR POWER SUPPLY

< DTC/CIRCUIT DIAGNOSIS >

[MR18DE]

3. CHECK SENSOR POWER SUPPLY CIRCUITS

Check harness for short to power and short to ground, between the following terminals.

ECM		Sensor		
Connector	Terminal	Name	Connector	Terminal
F8	72	Electric throttle control actuator	F29	2
	78	CMP sensor (PHASE)	F26	1
E16	106	APP sensor	E110	4

Is the inspection result normal?

YES >> GO TO 4.

NO >> Repair short to ground or short to power in harness or connectors.

4. CHECK COMPONENTS

Check the following.

- Camshaft position sensor (PHASE) (Refer to [EC-231, "Component Inspection"](#).)

Is the inspection result normal?

YES >> GO TO 5.

NO >> Replace camshaft position sensor (PHASE).

5. CHECK TP SENSOR

Refer to [EC-157, "Component Inspection"](#).

Is the inspection result normal?

YES >> GO TO 9.

NO >> GO TO 6.

6. REPLACE ELECTRIC THROTTLE CONTROL ACTUATOR

1. Replace electric throttle control actuator.
2. Perform [EC-17, "ACCELERATOR PEDAL RELEASED POSITION LEARNING : Special Repair Requirement"](#).

>> INSPECTION END

7. CHECK APP SENSOR

Refer to [EC-370, "Component Inspection"](#).

Is the inspection result normal?

YES >> GO TO 9.

NO >> GO TO 8.

8. REPLACE ACCELERATOR PEDAL ASSEMBLY

1. Replace accelerator pedal assembly.
2. Perform [EC-370, "Special Repair Requirement"](#).

>> INSPECTION END

9. CHECK INTERMITTENT INCIDENT

Refer to [GI-34, "Intermittent Incident"](#).

>> INSPECTION END

P0850 PNP SWITCH

< DTC/CIRCUIT DIAGNOSIS >

[MR18DE]

P0850 PNP SWITCH

Description

INFOID:000000004833431

For CVT models, transmission range switch is turn ON when the selector lever is P or N.
For M/T models, park/neutral position (PNP) range switch is ON when the selector lever is Neutral position.
ECM detects the position because the continuity of the line (the ON) exists.

DTC Logic

INFOID:000000004833432

DTC DETECTION LOGIC

DTC No.	Trouble diagnosis name	DTC detecting condition	Possible cause
P0850	Park/neutral position switch	For CVT models, the signal of transmission range switch is not changed in the process of engine starting and driving. For M/T models, the signal of the park/neutral position (PNP) switch is not changed in the process of engine starting and driving.	<ul style="list-style-type: none">• Harness or connectors [The transmission range switch circuit is open or shorted.(CVT models)] [The park/neutral position (PNP) switch circuit is open or shorted.(M/T models)]• Transmission range switch (CVT models)• Park/neutral position (PNP) switch (M/T models)

DTC CONFIRMATION PROCEDURE

1.INSPECTION START

Do you have CONSULT-III?

Do you have CONSULT-III?

YES >> GO TO 2.

NO >> GO TO 5.

2.PRECONDITIONING

If DTC Confirmation Procedure has been previously conducted, always turn ignition switch OFF and wait at least 10 seconds before conducting the next test.

>> GO TO 3.

3.CHECK PNP SWITCH FUNCTION

With CONSULT-III

1. Turn ignition switch ON.
2. Select "P/N POSI SW" in "DATA MONITOR" mode with CONSULT-III. Then check the "P/N POSI SW" signal under the following conditions.

Selector lever position	Known-good signal
N or P position (CVT) Neutral position (M/T)	ON
Except above position	OFF

Is the inspection result normal?

YES >> GO TO 4.

NO >> Go to [EC-311. "Diagnosis Procedure"](#).

4.PERFORM DTC CONFIRMATION PROCEDURE

1. Select "DATA MONITOR" mode with CONSULT-III.
2. Start engine and warm it up to normal operating temperature.
3. Maintain the following conditions for at least 60 consecutive seconds.

CAUTION:

Always drive vehicle at a safe speed.

P0850 PNP SWITCH

< DTC/CIRCUIT DIAGNOSIS >

[MR18DE]

ENG SPEED	1,200 - 6,375 rpm
COOLAN TEMP/S	More than 70°C (158°F)
B/FUEL SCHDL	2.5 - 31.8 msec
VHCL SPEED SE	More than 64 km/h (40 mph)
Selector lever	Suitable position

4. Check 1st trip DTC.

Is 1st trip DTC detected?

- YES >> Go to [EC-311, "Diagnosis Procedure"](#).
- NO >> INSPECTION END

5.PERFORM COMPONENT FUNCTION CHECK

Perform component function check. Refer to [EC-311, "Component Function Check"](#).

NOTE:

Use component function check the overall function of the transmission range switch circuit (CVT models) or the park/neutral position (PNP) switch circuit (M/T models). During this check, a 1st trip DTC might not be confirmed.

Is the inspection result normal?

- YES >> INSPECTION END
- NO >> Go to [EC-311, "Diagnosis Procedure"](#).

Component Function Check

INFOID:000000004833433

1.PERFORM COMPONENT FUNCTION CHECK

1. Turn ignition switch ON.
2. Check the voltage between ECM harness connector and ground under the following conditions.

ECM		Ground	Condition	Voltage
Connector	Terminal			
F8	69 (PNP switch signal)	Ground	P or N (CVT) Neutral (M/T)	Approx. 0 V
			Except above	Battery voltage

Is the inspection result normal?

- YES >> INSPECTION END
- NO >> Go to [EC-311, "Diagnosis Procedure"](#).

Diagnosis Procedure

INFOID:000000004833435

1.CHECK TRANSMISSION RANGE SWITCH (CVT) OR PNP SWITCH (M/T) POWER SUPPLY CIRCUIT

1. Turn ignition switch OFF.
2. Disconnect transmission range switch (CVT) or park/neutral position (PNP) switch (M/T) harness connector.
3. Turn ignition switch ON.
4. Check the voltage between transmission range switch (CVT) or PNP switch (M/T) harness connector and ground.

Transmission range switch (CVT) / PNP switch (M/T)		Ground	Voltage
Connector	Terminal		
F21 (CVT)	1	Ground	Battery voltage
F23 (M/T)	2		

Is the inspection result normal?

- YES >> GO TO 3.

P0850 PNP SWITCH

[MR18DE]

< DTC/CIRCUIT DIAGNOSIS >

NO >> GO TO 2.

2. DETECT MALFUNCTIONING PART

Check the following.

- Harness connectors E8, F1
- IPDM E/R harness connector E43 (M/T)
- IPDM E/R harness connector E45 (CVT)
- 10 A fuse (No. 51) (M/T)
- 10 A fuse (No. 54) (CVT)
- Harness for open or short between PNP switch and fuse

Is the inspection result normal?

>> Repair open circuit or short to ground or short to power in harness or connectors.

3. CHECK PNP SWITCH INPUT SIGNAL CIRCUIT FOR OPEN AND SHORT

1. Turn ignition switch OFF.
2. Disconnect ECM harness connector.
3. Check the continuity between transmission range switch (CVT) or PNP switch (M/T) harness connector and ECM harness connector.

Transmission range switch (CVT) / PNP switch (M/T)		ECM		Continuity
Connector	Terminal	Connector	Terminal	
F21 (CVT)	2	F8	69	Existed
F23 (M/T)	3			

4. Also check harness for short to ground and short to power.

Is the inspection result normal?

YES >> GO TO 4.

NO >> Repair open circuit or short to ground or short to power in harness or connectors.

4. CHECK TRANSMISSION RANGE SWITCH (CVT) OR PNP SWITCH (M/T)

Refer to [TM-103. "Component Inspection \(Park/Neutral Position Switch\)"](#) (CVT) or [TM-8. "PARK/NEUTRAL POSITION \(PNP\) SWITCH : Component Inspection"](#) (M/T).

Is the inspection result normal?

YES >> GO TO 5.

NO >> Replace transmission range switch (CVT) or PNP switch (M/T).

5. CHECK INTERMITTENT INCIDENT

Refer to [GI-34. "Intermittent Incident"](#).

>> INSPECTION END

P1148 CLOSED LOOP CONTROL

< DTC/CIRCUIT DIAGNOSIS >

[MR18DE]

P1148 CLOSED LOOP CONTROL

DTC Logic

INFOID:000000004833436

DTC DETECTION LOGIC

NOTE:

**DTC P1148 is displayed with another DTC for A/F sensor 1.
Perform the trouble diagnosis for the corresponding DTC.**

DTC No.	Trouble diagnosis name	DTC detecting condition	Possible cause
P1148	Closed loop control function	The closed loop control function for bank 1 does not operate even when vehicle is driving in the specified condition.	<ul style="list-style-type: none">• Harness or connectors (The A/F sensor 1 circuit is open or shorted.)• A/F sensor 1• A/F sensor 1 heater
		The closed loop control function for bank 2 does not operate even when vehicle is driving in the specified condition.	

A

EC

C

D

E

F

G

H

I

J

K

L

M

N

O

P

P1212 TCS COMMUNICATION LINE

< DTC/CIRCUIT DIAGNOSIS >

[MR18DE]

P1212 TCS COMMUNICATION LINE

Description

INFOID:000000004922382

This CAN communication line is used to control the smooth engine operation during the TCS operation. Pulse signals are exchanged between ECM and “ABS actuator and electric unit (control unit)”.

Be sure to erase the malfunction information such as DTC not only for “ABS actuator and electric unit (control unit)” but also for ECM after TCS related repair.

DTC Logic

INFOID:000000004922383

DTC DETECTION LOGIC

NOTE:

- If DTC P1212 is displayed with DTC U1001, first perform the trouble diagnosis for DTC U1001. Refer to [EC-120, "DTC Logic"](#).
- If DTC P1212 is displayed with DTC P0607, first perform the trouble diagnosis for DTC P0607. Refer to [EC-307, "DTC Logic"](#).

Freeze frame data is not stored in the ECM for this self-diagnosis.

DTC No.	Trouble diagnosis name	DTC detecting condition	Possible cause
P1212	TCS communication line	ECM can not receive the information from “ABS actuator and electric unit (control unit)” continuously.	<ul style="list-style-type: none">• Harness or connectors (The CAN communication line is open or shorted.)• ABS actuator and electric unit (control unit)• Dead (Weak) battery

DTC CONFIRMATION PROCEDURE

1. PRECONDITIONING

TESTING CONDITION:

Before performing the following procedure, confirm that battery voltage is more than 10.5V at idle.

>> GO TO 2.

2. PERFORM DTC CONFIRMATION PROCEDURE

1. Start engine and let it idle for at least 10 seconds.
2. Check 1st trip DTC.

Is 1st trip DTC detected?

- YES >> Go to [EC-314, "Diagnosis Procedure"](#).
NO >> INSPECTION END

Diagnosis Procedure

INFOID:000000004922384

Go to [GI-30, "Work Flow"](#).

P1217 ENGINE OVER TEMPERATURE

< DTC/CIRCUIT DIAGNOSIS >

[MR18DE]

P1217 ENGINE OVER TEMPERATURE

DTC Logic

INFOID:000000004833437

DTC DETECTION LOGIC

NOTE:

- If DTC P1217 is displayed with DTC UXXXX, first perform the trouble diagnosis for DTC UXXXX.
- If DTC P1217 is displayed with DTC P0607, first perform the trouble diagnosis for DTC P0607. Refer to [EC-307, "DTC Logic"](#).

If the cooling fan or another component in the cooling system malfunctions, engine coolant temperature will rise.

When the engine coolant temperature reaches an abnormally high temperature condition, a malfunction is indicated.

DTC No.	Trouble diagnosis name	DTC detecting condition	Possible cause
P1217	Engine over temperature (Overheat)	<ul style="list-style-type: none"> • Cooling fan does not operate properly (Overheat). • Cooling fan system does not operate properly (Overheat). • Engine coolant was not added to the system using the proper filling method. • Engine coolant is not within the specified range. 	<ul style="list-style-type: none"> • Harness or connectors (The cooling fan circuit is open or shorted.) • IPDM E/R (Cooling fan relay-1) • Cooling fan relays-2 and -3 • Cooling fan motor • Radiator hose • Radiator • Radiator cap • Reservoir tank • Water pump • Thermostat • Water control valve

CAUTION:

When a malfunction is indicated, be sure to replace the coolant. Refer to [CO-9, "Draining"](#). Also, replace the engine oil. Refer to [LU-8, "Refilling"](#).

1. Fill radiator with coolant up to specified level with a filling speed of 2 liters per minute. Be sure to use coolant with the proper mixture ratio. Refer to [MA-11, "Anti-Freeze Coolant Mixture Ratio"](#).
2. After refilling coolant, run engine to ensure that no water-flow noise is emitted.

DTC CONFIRMATION PROCEDURE

1. PERFORM COMPONENT FUNCTION CHECK

Perform component function check. Refer to [EC-315, "Component Function Check"](#).

NOTE:

Use component function check to check the overall function of the cooling fan. During this check, a DTC might not be confirmed.

Is the inspection result normal?

YES >> INSPECTION END

NO >> Go to [EC-316, "Diagnosis Procedure"](#).

Component Function Check

INFOID:000000004833438

1. PERFORM COMPONENT FUNCTION CHECK-I

WARNING:

Never remove the radiator cap when the engine is hot. Serious burns could be caused by high pressure fluid escaping from the radiator.

Wrap a thick cloth around cap. Carefully remove the cap by turning it a quarter turn to allow built-up pressure to escape. Then turn the cap all the way off.

P1217 ENGINE OVER TEMPERATURE

[MR18DE]

< DTC/CIRCUIT DIAGNOSIS >

Check the coolant level in the reservoir tank and radiator.

Allow engine to cool before checking coolant level.

Is the coolant level in the reservoir tank and/or radiator below the proper range?

- YES >> Go to [EC-316, "Diagnosis Procedure"](#).
NO >> GO TO 2.

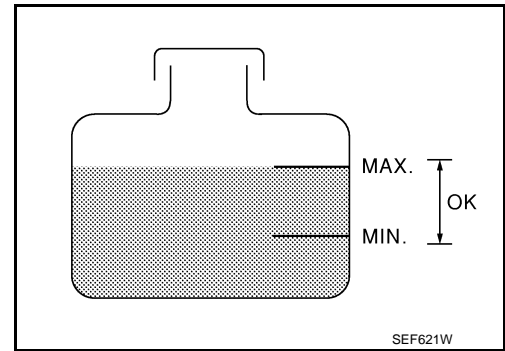

2.PERFORM COMPONENT FUNCTION CHECK-II

Confirm whether customer filled the coolant or not.

Did customer fill the coolant?

- YES >> Go to [EC-316, "Diagnosis Procedure"](#).
NO >> GO TO 3.

3.PERFORM COMPONENT FUNCTION CHECK-III

With CONSULT-III

1. Turn ignition switch ON.
2. Perform "COOLING FAN" in "ACTIVE TEST" mode with CONSULT-III.
3. Make sure that cooling fan motor operates at each speed (LOW/HI).

Without CONSULT-III

Perform IPDM E/R auto active test and check cooling fan motor operation. Refer to [PCS-11, "Diagnosis Description"](#).

Is the inspection result normal?

- YES >> INSPECTION END
NO >> Go to [EC-316, "Diagnosis Procedure"](#).

Diagnosis Procedure

INFOID:000000004833439

1.CHECK COOLING FAN OPERATION

With CONSULT-III

1. Turn ignition switch ON.
2. Perform "COOLING FAN" in "ACTIVE TEST" mode with CONSULT-III.
3. Make sure that cooling fan motor operates at each speed (LOW/HI).

Without CONSULT-III

1. Perform IPDM E/R auto active test and check cooling fan motor operation. Refer to [PCS-11, "Diagnosis Description"](#).
2. Make sure that cooling fan motor operates at each speed (Low/High).

Is the inspection result normal?

- YES >> GO TO 2.
NO >> Go to [EC-391, "Diagnosis Procedure"](#).

2.CHECK COOLING SYSTEM FOR LEAK-I

Check cooling system for leak. Refer to [CO-9, "Inspection"](#).

Is leakage detected?

- YES >> GO TO 3.
NO >> GO TO 4.

3.CHECK COOLING SYSTEM FOR LEAK-II

Check the following for leak.

- Hose (Refer to [CO-23, "Inspection"](#).)
- Radiator (Refer to [CO-15, "Inspection"](#).)
- Water pump (Refer to [CO-18, "Inspection"](#).)

P1217 ENGINE OVER TEMPERATURE

< DTC/CIRCUIT DIAGNOSIS >

[MR18DE]

>> Repair or replace malfunctioning part.

4.CHECK RADIATOR CAP

Check radiator cap. Refer to [CO-12, "RADIATOR CAP : Inspection"](#).

Is the inspection result normal?

YES >> GO TO 5.

NO >> Replace radiator cap.

5.CHECK THERMOSTAT

Check thermostat. Refer to [CO-21, "Inspection"](#).

Is the inspection result normal?

YES >> GO TO 6.

NO >> Replace thermostat.

6.CHECK WATER CONTROL VALVE

Check water control valve. Refer to [CO-24, "Water Control Valve"](#).

Is the inspection result normal?

YES >> GO TO 7.

NO >> Replace water control valve

7.CHECK ENGINE COOLANT TEMPERATURE SENSOR

Refer to [EC-153, "Component Inspection"](#).

Is the inspection result normal?

YES >> GO TO 8.

NO >> Replace engine coolant temperature sensor.

8.CHECK MAIN 12 CAUSES

If the cause cannot be isolated, check the following.

Engine	Step	Inspection item	Equipment	Standard	Reference page
OFF	1	<ul style="list-style-type: none"> Blocked radiator Blocked condenser Blocked radiator grille Blocked bumper 	<ul style="list-style-type: none"> Visual 	No blocking	—
	2	<ul style="list-style-type: none"> Coolant mixture 	<ul style="list-style-type: none"> Coolant tester 	MA-11, "Anti-Freeze Coolant Mixture Ratio"	
	3	<ul style="list-style-type: none"> Coolant level 	<ul style="list-style-type: none"> Visual 	Coolant up to MAX level in reservoir tank and radiator filler neck	CO-9, "Inspection"
	4	<ul style="list-style-type: none"> Radiator cap 	<ul style="list-style-type: none"> Pressure tester 	CO-12, "RADIATOR CAP : Inspection"	
ON*2	5	<ul style="list-style-type: none"> Coolant leaks 	<ul style="list-style-type: none"> Visual 	No leaks	CO-9, "Inspection"
ON*2	6	<ul style="list-style-type: none"> Thermostat 	<ul style="list-style-type: none"> Touch the upper and lower radiator hoses 	Both hoses should be hot	CO-21, "Inspection"
ON*1	7	<ul style="list-style-type: none"> Cooling fan motor 	<ul style="list-style-type: none"> CONSULT-III 	Operating	EC-391, "Component Function Check"
OFF	8	<ul style="list-style-type: none"> Combustion gas leak 	<ul style="list-style-type: none"> Color checker chemical tester 4 Gas analyzer 	Negative	—
ON*3	9	<ul style="list-style-type: none"> Coolant temperature gauge 	<ul style="list-style-type: none"> Visual 	Gauge less than 3/4 when driving	—
		<ul style="list-style-type: none"> Coolant overflow to reservoir tank 	<ul style="list-style-type: none"> Visual 	No overflow during driving and idling	CO-9, "Inspection"
OFF*4	10	<ul style="list-style-type: none"> Coolant return from reservoir tank to radiator 	<ul style="list-style-type: none"> Visual 	Should be initial level in reservoir tank	CO-9, "Inspection"

P1217 ENGINE OVER TEMPERATURE

[MR18DE]

< DTC/CIRCUIT DIAGNOSIS >

Engine	Step	Inspection item	Equipment	Standard	Reference page
OFF	11	<ul style="list-style-type: none">• Cylinder head	<ul style="list-style-type: none">• Straight gauge feeler gauge	0.1 mm (0.004 in) Maximum distortion (warping)	EM-67, "Disassembly and Assembly"
	12	<ul style="list-style-type: none">• Cylinder block and pistons	<ul style="list-style-type: none">• Visual	No scuffing on cylinder walls or piston	EM-95, "Inspection"

*1: Turn the ignition switch ON.

*2: Engine running at 3,000 rpm for 10 minutes.

*3: Drive at 90 km/h (56 MPH) for 30 minutes and then let idle for 10 minutes.

*4: After 60 minutes of cool down time.

For more information, refer to [CO-4, "Troubleshooting Chart"](#).

>> INSPECTION END

P1225 TP SENSOR

< DTC/CIRCUIT DIAGNOSIS >

[MR18DE]

P1225 TP SENSOR

Description

INFOID:000000004833440

Electric throttle control actuator consists of throttle control motor, throttle position sensor, etc. The throttle position sensor responds to the throttle valve movement.

The throttle position sensor has two sensors. These sensors are a kind of potentiometer which transform the throttle valve position into output voltage, and emit the voltage signals to the ECM. The ECM judges the current opening angle of the throttle valve from these signals and controls the throttle valve opening angle in response to driving conditions via the throttle control motor.

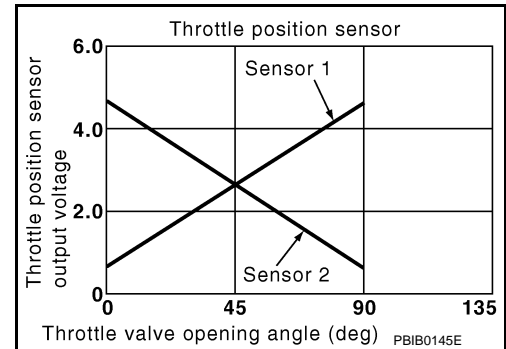

DTC Logic

INFOID:000000004833441

DTC DETECTION LOGIC

DTC No.	Trouble diagnosis name	DTC detecting condition	Possible cause
P1225	Closed throttle position learning performance	Closed throttle position learning value is excessively low.	• Electric throttle control actuator (TP sensor 1 and 2)

DTC CONFIRMATION PROCEDURE

1. PRECONDITIONING

If DTC Confirmation Procedure has been previously conducted, always turn ignition switch OFF and wait at least 10 seconds before conducting the next test.

TESTING CONDITION:

Before performing the following procedure, confirm that battery voltage is more than 10 V at idle.

>> GO TO 2.

2. PERFORM DTC CONFIRMATION PROCEDURE

1. Turn ignition switch ON.
2. Turn ignition switch OFF and wait at least 10 seconds.
3. Turn ignition switch ON.
4. Check 1st trip DTC.

Is 1st trip DTC detected?

- YES >> Go to [EC-319. "Diagnosis Procedure"](#).
NO >> INSPECTION END

Diagnosis Procedure

INFOID:000000004833442

1. CHECK ELECTRIC THROTTLE CONTROL ACTUATOR VISUALLY

1. Turn ignition switch OFF.
2. Remove the intake air duct.

P1225 TP SENSOR

[MR18DE]

< DTC/CIRCUIT DIAGNOSIS >

3. Check if foreign matter is caught between the throttle valve (1) and the housing.
 - Electric throttle control actuator (2)

Is the inspection result normal?

YES >> GO TO 2.

NO >> Remove the foreign matter and clean the electric throttle control actuator inside.

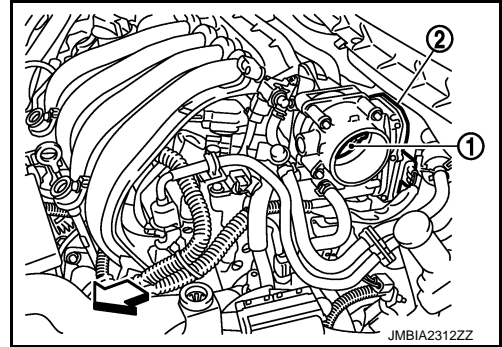

2. REPLACE ELECTRIC THROTTLE CONTROL ACTUATOR

1. Replace electric throttle control actuator.
2. Perform [EC-320. "Special Repair Requirement"](#).

>> INSPECTION END

Special Repair Requirement

INFOID:000000004833443

1. PERFORM THROTTLE VALVE CLOSED POSITION LEARNING

Refer to [EC-17, "THROTTLE VALVE CLOSED POSITION LEARNING : Special Repair Requirement"](#)

>> GO TO 2.

2. PERFORM IDLE AIR VOLUME LEARNING

Refer to [EC-17, "IDLE AIR VOLUME LEARNING : Special Repair Requirement"](#)

>> END

P1226 TP SENSOR

< DTC/CIRCUIT DIAGNOSIS >

[MR18DE]

P1226 TP SENSOR

Description

INFOID:000000004833444

Electric throttle control actuator consists of throttle control motor, throttle position sensor, etc. The throttle position sensor responds to the throttle valve movement.

The throttle position sensor has two sensors. These sensors are a kind of potentiometer which transform the throttle valve position into output voltage, and emit the voltage signals to the ECM. The ECM judges the current opening angle of the throttle valve from these signals and controls the throttle valve opening angle in response to driving conditions via the throttle control motor.

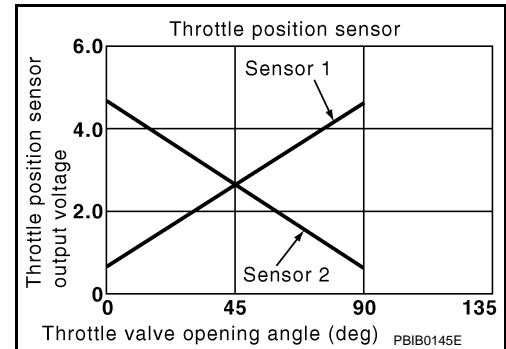

DTC Logic

INFOID:000000004833445

DTC DETECTION LOGIC

DTC No.	Trouble diagnosis name	DTC detecting condition	Possible cause
P1226	Closed throttle position learning performance	Closed throttle position learning is not performed successfully, repeatedly.	• Electric throttle control actuator (TP sensor 1 and 2)

DTC CONFIRMATION PROCEDURE

1. PRECONDITIONING

If DTC Confirmation Procedure has been previously conducted, always turn ignition switch OFF and wait at least 10 seconds before conducting the next test.

TESTING CONDITION:

Before performing the following procedure, confirm that battery voltage is more than 10 V at idle.

>> GO TO 2.

2. PERFORM DTC CONFIRMATION PROCEDURE

1. Turn ignition switch ON.
2. Turn ignition switch OFF, wait at least 10 seconds.
3. Turn ignition switch ON.
4. Repeat steps 2 and 3 for 32 times.
5. Check 1st trip DTC.

Is 1st trip DTC detected?

- YES >> Go to [EC-321, "Diagnosis Procedure"](#).
NO >> INSPECTION END

Diagnosis Procedure

INFOID:000000004833446

1. CHECK ELECTRIC THROTTLE CONTROL ACTUATOR VISUALLY

1. Turn ignition switch OFF.
2. Remove the intake air duct.

P1226 TP SENSOR

[MR18DE]

< DTC/CIRCUIT DIAGNOSIS >

3. Check if foreign matter is caught between the throttle valve (1) and the housing.
 - Electric throttle control actuator (2)

Is the inspection result normal?

YES >> GO TO 2.

NO >> Remove the foreign matter and clean the electric throttle control actuator inside.

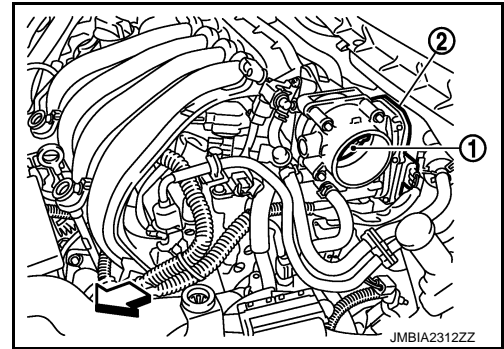

2. REPLACE ELECTRIC THROTTLE CONTROL ACTUATOR

1. Replace electric throttle control actuator.
2. Perform [EC-322. "Special Repair Requirement"](#).

>> INSPECTION END

Special Repair Requirement

INFOID:000000004833447

1. PERFORM THROTTLE VALVE CLOSED POSITION LEARNING

Refer to [EC-17, "THROTTLE VALVE CLOSED POSITION LEARNING : Special Repair Requirement"](#)

>> GO TO 2.

2. PERFORM IDLE AIR VOLUME LEARNING

Refer to [EC-17, "IDLE AIR VOLUME LEARNING : Special Repair Requirement"](#)

>> END

P1421 COLD START CONTROL

< DTC/CIRCUIT DIAGNOSIS >

[MR18DE]

P1421 COLD START CONTROL

Description

INFOID:000000004833448

ECM controls ignition timing and engine idle speed when engine is started with pre-warming up condition. This control promotes the activation of three way catalyst by heating the catalyst and reduces emissions.

DTC Logic

INFOID:000000004833449

DTC DETECTION LOGIC

NOTE:

If DTC P1421 is displayed with other DTC, first perform the trouble diagnosis for other DTC.

DTC No.	Trouble diagnosis name	DTC detecting condition	Possible cause
P1421	Cold start emission reduction strategy monitoring	ECM does not control ignition timing and engine idle speed properly when engine is started with pre-warming up condition.	<ul style="list-style-type: none">Lack of intake air volumeFuel injection systemECM

DTC CONFIRMATION PROCEDURE

1. PRECONDITIONING

If DTC Confirmation Procedure has been previously conducted, always turn ignition switch OFF and wait at least 10 seconds before conducting the next test.

TESTING CONDITION:

Before performing the following procedure, confirm that battery voltage is more than 11 V at idle.

>> GO TO 2.

2. PERFORM DTC CONFIRMATION PROCEDURE

With CONSULT-III

- Turn ignition switch OFF and wait at least 10 seconds.
- Turn ignition switch ON.
- Select "DATA MONITOR" mode with CONSULT-III.
- Check that the "COOLAN TEMP/S" indication is between 4°C (39°F) and 36°C (97°F).
If "COOLAN TEMP/S" indication is within the specified value, go to the following step.
If "COOLAN TEMP/S" indication is out of the specified value, cool engine down or warm engine up and go to step 1.
- Start engine and let it idle for 5 minutes.
- Check 1st trip DTC.

With GST

Follow the procedure "With CONSULT-III" above.

Is 1st trip DTC detected?

- YES >> Go to [EC-323, "Diagnosis Procedure"](#).
NO >> INSPECTION END

Diagnosis Procedure

INFOID:000000004833450

1. PERFORM IDLE AIR VOLUME LEARNING

Perform [EC-17, "IDLE AIR VOLUME LEARNING : Special Repair Requirement"](#).

Is Idle Air Volume Learning carried out successfully?

- YES >> GO TO 2.
NO >> Follow the instruction of Idle Air Volume Learning.

2. CHECK INTAKE SYSTEM

Check for the cause of intake air volume lacking. Refer to the following.

- Crushed intake air passage
- Intake air passage clogging

P1421 COLD START CONTROL

[MR18DE]

< DTC/CIRCUIT DIAGNOSIS >

Is the inspection result normal?

YES >> GO TO 3.

NO >> Repair or replace malfunctioning part

3. CHECK FUEL INJECTION SYSTEM FUNCTION

Perform DTC CONFIRMATION PROCEDURE for DTC P0171. Refer to [EC-200. "DTC Logic"](#).

Is the inspection result normal?

YES >> GO TO 4.

NO >> Go to [EC-201. "Diagnosis Procedure"](#) for DTC P0171.

4. PERFORM DTC CONFIRMATION PROCEDURE

1. Turn ignition switch ON.
2. Erase 1st trip DTC. Refer to "How to Erase DTC and 1st Trip DTC" in [EC-85. "Diagnosis Description"](#).
3. Perform DTC CONFIRMATION PROCEDURE. Refer to [EC-323. "DTC Logic"](#).

Is the 1st trip DTC P1421 displayed again?

YES >> GO TO 5.

NO >> INSPECTION END

5. REPLACE ECM

1. Replace ECM.
2. Perform [EC-15. "ADDITIONAL SERVICE WHEN REPLACING CONTROL UNIT : Special Repair Requirement"](#).

>> INSPECTION END

P1550 BATTERY CURRENT SENSOR

< DTC/CIRCUIT DIAGNOSIS >

[MR18DE]

P1550 BATTERY CURRENT SENSOR

Description

INFOID:000000005151142

The power generation voltage variable control enables fuel consumption to be decreased by reducing the engine load which is caused by the power generation of the generator. The battery current sensor is installed to the battery cable at the negative terminal. The sensor measures the charging/discharging current of the battery. Based on the sensor signal, ECM judges whether or not the power generation voltage variable control is performed. When performing the power generation voltage variable control, ECM calculates the target power generation voltage based on the sensor signal. And ECM sends the calculated value as the power generation command value to IPDM E/R. For the details of the power generation voltage variable control, refer to [PCS-69. "System Description"](#).

CAUTION:

Never connect the electrical component or the ground wire directly to the battery terminal. The connection causes the malfunction of the power generation voltage variable control, and then the battery discharge may occur.

DTC Logic

INFOID:000000005151143

DTC DETECTION LOGIC

DTC No.	Trouble diagnosis name	DTC detecting condition	Possible cause
P1550	Battery current sensor circuit range/performance	The output voltage of the battery current sensor remains within the specified range while engine is running.	<ul style="list-style-type: none">• Harness or connectors (Battery current sensor circuit is open or shorted.) [Crankshaft position sensor (POS) circuit is shorted.] (EVAP control system pressure sensor circuit is shorted.) (Accelerator pedal position sensor circuit is shorted.) (Refrigerant pressure sensor circuit is shorted.)• Battery current sensor• Crankshaft position sensor (POS)• EVAP control system pressure sensor• Accelerator pedal position sensor• Refrigerant pressure sensor

DTC CONFIRMATION PROCEDURE

1. PRECONDITIONING

If DTC Confirmation Procedure has been previously conducted, always perform the following before conducting the next test.

1. Turn ignition switch OFF and wait at least 10 seconds.
2. Turn ignition switch ON.
3. Turn ignition switch OFF and wait at least 10 seconds.

TESTING CONDITION:

Before performing the following procedure, confirm that battery voltage is more than 8 V at idle.

>> GO TO 2.

2. PERFORM DTC CONFIRMATION PROCEDURE

1. Start engine and wait at least 10 seconds.
2. Check 1st trip DTC.

Is 1st trip DTC detected?

- YES >> Go to [EC-326. "Diagnosis Procedure"](#).
NO >> INSPECTION END

P1550 BATTERY CURRENT SENSOR

[MR18DE]

< DTC/CIRCUIT DIAGNOSIS >

INFOID:000000005151144

Diagnosis Procedure

1. CHECK GROUND CONNECTION

1. Turn ignition switch OFF.
2. Check ground connection E38. Refer to Ground Inspection in [GI-37. "Circuit Inspection"](#).

Is the inspection result normal?

- YES >> GO TO 2.
NO >> Repair or replace ground connection.

2. CHECK BATTERY CURRENT SENSOR POWER SUPPLY CIRCUIT-I

1. Disconnect battery current sensor harness connector.
2. Turn ignition switch ON.
3. Check the voltage between battery current sensor harness connector and ground.

Battery current sensor		Ground	Voltage
Connector	Terminal		
F53	1	Ground	Approx. 5 V

Is the inspection result normal?

- YES >> GO TO 8.
NO >> GO TO 3.

3. CHECK BATTERY CURRENT SENSOR POWER SUPPLY CIRCUIT-II

1. Turn ignition switch OFF.
2. Disconnect ECM harness connector.
3. Check the continuity between battery current sensor harness connector and ECM harness connector.

Battery current sensor		ECM		Continuity
Connector	Terminal	Connector	Terminal	
F53	1	F8	77	Existed

Is the inspection result normal?

- YES >> GO TO 4.
NO >> Repair open circuit.

4. CHECK SENSOR POWER SUPPLY CIRCUIT

Check harness for short to power and short to ground, between the following terminals.

ECM		Sensor		
Connector	Terminal	Name	Connector	Terminal
F8	74	Refrigerant pressure sensor	E49	1
	75	CKP sensor (POS)	F20	1
	76	EVAP control system pressure sensor	B21	3
	77	Battery current sensor	F53	1
E16	102	APP sensor	E110	5

Is the inspection result normal?

- YES >> GO TO 5.
NO >> Repair short to ground or short to power in harness or connectors.

5. CHECK COMPONENTS

Check the following.

- Crankshaft position sensor (POS) (Refer to [EC-228. "Component Inspection"](#).)
- EVAP control system pressure sensor (Refer to [EC-269. "Component Inspection"](#).)
- Refrigerant pressure sensor (Refer to [EC-414. "Diagnosis Procedure"](#).)

P1550 BATTERY CURRENT SENSOR

[MR18DE]

< DTC/CIRCUIT DIAGNOSIS >

Is the inspection result normal?

- YES >> GO TO 6.
- NO >> Replace malfunctioning components.

6.CHECK APP SENSOR

Refer to [EC-381, "Component Inspection"](#).

Is the inspection result normal?

- YES >> GO TO 11.
- NO >> GO TO 7.

7.REPLACE ACCELERATOR PEDAL ASSEMBLY

1. Replace accelerator pedal assembly.
2. Go to [EC-381, "Special Repair Requirement"](#).

>> INSPECTION END

8.CHECK BATTERY CURRENT SENSOR GROUND CIRCUIT FOR OPEN AND SHORT

1. Turn ignition switch OFF.
2. Disconnect ECM harness connector.
3. Check the continuity between battery current sensor harness connector and ECM harness connector.

Battery current sensor		ECM		Continuity
Connector	Terminal	Connector	Terminal	
F53	2	F8	68	Existed

4. Also check harness for short to ground and short to power.

Is the inspection result normal?

- YES >> GO TO 9.
- NO >> Repair open circuit, short to ground or short to power in harness or connectors.

9.CHECK BATTERY CURRENT SENSOR INPUT SIGNAL CIRCUIT FOR OPEN AND SHORT

1. Check the continuity between battery current sensor harness connector and ECM harness connector.

Battery current sensor		ECM		Continuity
Connector	Terminal	Connector	Terminal	
F53	3	F8	58	Existed

2. Also check harness for short to ground and short to power.

Is the inspection result normal?

- YES >> GO TO 10.
- NO >> Repair open circuit, short to ground or short to power in harness or connectors.

10.CHECK BATTERY CURRENT SENSOR

Refer to [EC-327, "Component Inspection"](#).

Is the inspection result normal?

- YES >> GO TO 11.
- NO >> Replace battery negative cable assembly.

11.CHECK INTERMITTENT INCIDENT

Refer to [GI-34, "Intermittent Incident"](#).

>> INSPECTION END

Component Inspection

INFOID:000000005151145

1.CHECK BATTERY CURRENT SENSOR

P1550 BATTERY CURRENT SENSOR

[MR18DE]

< DTC/CIRCUIT DIAGNOSIS >

1. Turn ignition switch OFF.
2. Reconnect harness connectors disconnected.
3. Disconnect battery negative cable.
4. Install jumper cable (A) between battery negative terminal and body ground.

1 : Battery negative terminal

← : To body ground

5. Turn ignition switch ON.
6. Check the voltage between ECM harness connector and ground.

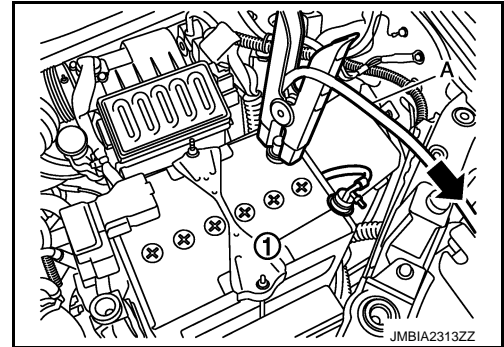

Connector	ECM		Voltage
	+	-	
	Terminal	Terminal	
F8	58 (Battery current sensor signal)	68	Approx. 2.5 V

Before measuring the terminal voltage, confirm that the battery is fully charged. Refer to [PG-3, "How to Handle Battery"](#).

Is the inspection result normal?

- YES >> INSPECTION END
NO >> Replace battery negative cable assembly.

P1551, P1552 BATTERY CURRENT SENSOR

< DTC/CIRCUIT DIAGNOSIS >

[MR18DE]

P1551, P1552 BATTERY CURRENT SENSOR

Description

INFOID:000000005184772

The power generation voltage variable control enables fuel consumption to be decreased by reducing the engine load which is caused by the power generation of the generator. The battery current sensor is installed to the battery cable at the negative terminal. The sensor measures the charging/discharging current of the battery. Based on the sensor signal, ECM judges whether or not the power generation voltage variable control is performed. When performing the power generation voltage variable control, ECM calculates the target power generation voltage based on the sensor signal. And ECM sends the calculated value as the power generation command value to IPDM E/R. For the details of the power generation voltage variable control, refer to [PCS-69. "System Description"](#).

CAUTION:

Never connect the electrical component or the ground wire directly to the battery terminal. The connection causes the malfunction of the power generation voltage variable control, and then the battery discharge may occur.

DTC Logic

INFOID:000000005151146

DTC DETECTION LOGIC

DTC No.	Trouble diagnosis name	DTC detecting condition	Possible cause
P1551	Battery current sensor circuit low input	An excessively low voltage from the sensor is sent to ECM.	<ul style="list-style-type: none">• Harness or connectors (Battery current sensor circuit is open or shorted.) [Crankshaft position sensor (POS) circuit is shorted.] (Power steering pressure sensor circuit is shorted.) (Accelerator pedal position sensor circuit is shorted.) (Refrigerant pressure sensor circuit is shorted.)• Battery current sensor• Crankshaft position sensor (POS)• Power steering pressure sensor• Accelerator pedal position sensor• Refrigerant pressure sensor
P1552	Battery current sensor circuit high input	An excessively high voltage from the sensor is sent to ECM.	

DTC CONFIRMATION PROCEDURE

1. PRECONDITIONING

If DTC Confirmation Procedure has been previously conducted, always perform the following before conducting the next test.

1. Turn ignition switch OFF and wait at least 10 seconds.
2. Turn ignition switch ON.
3. Turn ignition switch OFF and wait at least 10 seconds.

TESTING CONDITION:

Before performing the following procedure, confirm that battery voltage is more than 8 V with ignition switch ON

>> GO TO 2.

2. PERFORM DTC CONFIRMATION PROCEDURE

1. Turn ignition switch ON and wait at least 10 seconds.
2. Check 1st trip DTC.

Is 1st trip DTC detected?

- YES >> Go to [EC-330. "Diagnosis Procedure"](#).
NO >> INSPECTION END

P1551, P1552 BATTERY CURRENT SENSOR

[MR18DE]

< DTC/CIRCUIT DIAGNOSIS >

INFOID:000000005184775

Diagnosis Procedure

1. CHECK GROUND CONNECTION

1. Turn ignition switch OFF.
2. Check ground connection E38. Refer to Ground Inspection in [GI-37. "Circuit Inspection"](#).

Is the inspection result normal?

- YES >> GO TO 2.
NO >> Repair or replace ground connection.

2. CHECK BATTERY CURRENT SENSOR POWER SUPPLY CIRCUIT-I

1. Disconnect battery current sensor harness connector.
2. Turn ignition switch ON.
3. Check the voltage between battery current sensor harness connector and ground.

Battery current sensor		Ground	Voltage
Connector	Terminal		
F53	1	Ground	Approx. 5 V

Is the inspection result normal?

- YES >> GO TO 8.
NO >> GO TO 3.

3. CHECK BATTERY CURRENT SENSOR POWER SUPPLY CIRCUIT-II

1. Turn ignition switch OFF.
2. Disconnect ECM harness connector.
3. Check the continuity between battery current sensor harness connector and ECM harness connector.

Battery current sensor		ECM		Continuity
Connector	Terminal	Connector	Terminal	
F53	1	F8	77	Existed

Is the inspection result normal?

- YES >> GO TO 4.
NO >> Repair open circuit.

4. CHECK SENSOR POWER SUPPLY CIRCUIT

Check harness for short to power and short to ground, between the following terminals.

ECM		Sensor		
Connector	Terminal	Name	Connector	Terminal
F8	74	Refrigerant pressure sensor	E49	1
	75	CKP sensor (POS)	F20	1
	76	EVAP control system pressure sensor	B21	3
	77	Battery current sensor	F53	1
E16	102	APP sensor	E110	5

Is the inspection result normal?

- YES >> GO TO 5.
NO >> Repair short to ground or short to power in harness or connectors.

5. CHECK COMPONENTS

Check the following.

- Crankshaft position sensor (POS) (Refer to [EC-228. "Component Inspection"](#).)
- EVAP control system pressure sensor (Refer to [EC-269. "Component Inspection"](#).)
- Refrigerant pressure sensor (Refer to [EC-414. "Diagnosis Procedure"](#).)

P1551, P1552 BATTERY CURRENT SENSOR

[MR18DE]

< DTC/CIRCUIT DIAGNOSIS >

Is the inspection result normal?

- YES >> GO TO 6.
- NO >> Replace malfunctioning components.

6.CHECK APP SENSOR

Refer to [EC-381, "Component Inspection"](#).

Is the inspection result normal?

- YES >> GO TO 11.
- NO >> GO TO 7.

7.REPLACE ACCELERATOR PEDAL ASSEMBLY

1. Replace accelerator pedal assembly.
2. Go to [EC-381, "Special Repair Requirement"](#).

>> INSPECTION END

8.CHECK BATTERY CURRENT SENSOR GROUND CIRCUIT FOR OPEN AND SHORT

1. Turn ignition switch OFF.
2. Disconnect ECM harness connector.
3. Check the continuity between battery current sensor harness connector and ECM harness connector.

Battery current sensor		ECM		Continuity
Connector	Terminal	Connector	Terminal	
F53	2	F8	68	Existed

4. Also check harness for short to ground and short to power.

Is the inspection result normal?

- YES >> GO TO 9.
- NO >> Repair open circuit, short to ground or short to power in harness or connectors.

9.CHECK BATTERY CURRENT SENSOR INPUT SIGNAL CIRCUIT FOR OPEN AND SHORT

1. Check the continuity between battery current sensor harness connector and ECM harness connector.

Battery current sensor		ECM		Continuity
Connector	Terminal	Connector	Terminal	
F53	3	F8	58	Existed

2. Also check harness for short to ground and short to power.

Is the inspection result normal?

- YES >> GO TO 10.
- NO >> Repair open circuit, short to ground or short to power in harness or connectors.

10.CHECK BATTERY CURRENT SENSOR

Refer to [EC-340, "Component Inspection"](#).

Is the inspection result normal?

- YES >> GO TO 11.
- NO >> Replace battery negative cable assembly.

11.CHECK INTERMITTENT INCIDENT

Refer to [GI-34, "Intermittent Incident"](#).

>> INSPECTION END

Component Inspection

INFOID:000000005184778

1.CHECK BATTERY CURRENT SENSOR

P1551, P1552 BATTERY CURRENT SENSOR

[MR18DE]

< DTC/CIRCUIT DIAGNOSIS >

1. Turn ignition switch OFF.
2. Reconnect harness connectors disconnected.
3. Disconnect battery negative cable.
4. Install jumper cable (A) between battery negative terminal and body ground.

1 : Battery negative terminal

← : To body ground

5. Turn ignition switch ON.
6. Check the voltage between ECM harness connector and ground.

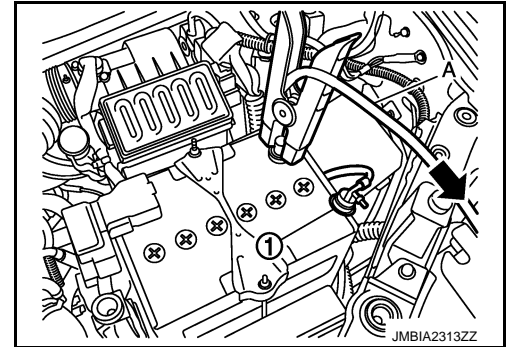

Connector	ECM		Voltage
	+	-	
	Terminal	Terminal	
F8	58 (Battery current sensor signal)	68	Approx. 2.5 V

Before measuring the terminal voltage, confirm that the battery is fully charged. Refer to [PG-3, "How to Handle Battery"](#).

Is the inspection result normal?

YES >> INSPECTION END

NO >> Replace battery negative cable assembly.

P1553 BATTERY CURRENT SENSOR

< DTC/CIRCUIT DIAGNOSIS >

[MR18DE]

P1553 BATTERY CURRENT SENSOR

Description

INFOID:000000005184773

The power generation voltage variable control enables fuel consumption to be decreased by reducing the engine load which is caused by the power generation of the generator. The battery current sensor is installed to the battery cable at the negative terminal. The sensor measures the charging/discharging current of the battery. Based on the sensor signal, ECM judges whether or not the power generation voltage variable control is performed. When performing the power generation voltage variable control, ECM calculates the target power generation voltage based on the sensor signal. And ECM sends the calculated value as the power generation command value to IPDM E/R. For the details of the power generation voltage variable control, refer to [PCS-69. "System Description"](#).

CAUTION:

Never connect the electrical component or the ground wire directly to the battery terminal. The connection causes the malfunction of the power generation voltage variable control, and then the battery discharge may occur.

DTC Logic

INFOID:000000005151147

DTC DETECTION LOGIC

DTC No.	Trouble diagnosis name	DTC detecting condition	Possible cause
P1553	Battery current sensor performance	The signal voltage transmitted from the sensor to ECM is higher than the amount of the maximum power generation.	<ul style="list-style-type: none">• Harness or connectors (Battery current sensor circuit is open or shorted.) [Crankshaft position sensor (POS) circuit is shorted.] (Power steering pressure sensor circuit is shorted.) (Accelerator pedal position sensor circuit is shorted.) (Refrigerant pressure sensor circuit is shorted.)• Battery current sensor• Crankshaft position sensor (POS)• Power steering pressure sensor• Accelerator pedal position sensor• Refrigerant pressure sensor

DTC CONFIRMATION PROCEDURE

1. PRECONDITIONING

If DTC Confirmation Procedure has been previously conducted, always perform the following before conducting the next test.

1. Turn ignition switch OFF and wait at least 10 seconds.
2. Turn ignition switch ON.
3. Turn ignition switch OFF and wait at least 10 seconds.

TESTING CONDITION:

Before performing the following procedure, confirm that battery voltage is more than 8 V at idle.

>> GO TO 2.

2. PERFORM DTC CONFIRMATION PROCEDURE

1. Start engine and wait at least 10 seconds.
2. Check 1st trip DTC.

Is 1st trip DTC detected?

- YES >> Go to [EC-334. "Diagnosis Procedure"](#).
NO >> INSPECTION END

P1553 BATTERY CURRENT SENSOR

[MR18DE]

< DTC/CIRCUIT DIAGNOSIS >

Diagnosis Procedure

INFOID:000000005184776

1. CHECK GROUND CONNECTION

1. Turn ignition switch OFF.
2. Check ground connection E38. Refer to Ground Inspection in [GI-37. "Circuit Inspection"](#).

Is the inspection result normal?

- YES >> GO TO 2.
NO >> Repair or replace ground connection.

2. CHECK BATTERY CURRENT SENSOR POWER SUPPLY CIRCUIT-I

1. Disconnect battery current sensor harness connector.
2. Turn ignition switch ON.
3. Check the voltage between battery current sensor harness connector and ground.

Battery current sensor		Ground	Voltage
Connector	Terminal		
F53	1	Ground	Approx. 5 V

Is the inspection result normal?

- YES >> GO TO 8.
NO >> GO TO 3.

3. CHECK BATTERY CURRENT SENSOR POWER SUPPLY CIRCUIT-II

1. Turn ignition switch OFF.
2. Disconnect ECM harness connector.
3. Check the continuity between battery current sensor harness connector and ECM harness connector.

Battery current sensor		ECM		Continuity
Connector	Terminal	Connector	Terminal	
F53	1	F8	77	Existed

Is the inspection result normal?

- YES >> GO TO 4.
NO >> Repair open circuit.

4. CHECK SENSOR POWER SUPPLY CIRCUIT

Check harness for short to power and short to ground, between the following terminals.

ECM		Sensor		
Connector	Terminal	Name	Connector	Terminal
F8	74	Refrigerant pressure sensor	E49	1
	75	CKP sensor (POS)	F20	1
	76	EVAP control system pressure sensor	B21	3
	77	Battery current sensor	F53	1
E16	102	APP sensor	E110	5

Is the inspection result normal?

- YES >> GO TO 5.
NO >> Repair short to ground or short to power in harness or connectors.

5. CHECK COMPONENTS

Check the following.

- Crankshaft position sensor (POS) (Refer to [EC-228. "Component Inspection"](#).)
- EVAP control system pressure sensor (Refer to [EC-269. "Component Inspection"](#).)
- Refrigerant pressure sensor (Refer to [EC-414. "Diagnosis Procedure"](#).)

P1553 BATTERY CURRENT SENSOR

[MR18DE]

< DTC/CIRCUIT DIAGNOSIS >

Is the inspection result normal?

- YES >> GO TO 6.
- NO >> Replace malfunctioning components.

6.CHECK APP SENSOR

Refer to [EC-381, "Component Inspection"](#).

Is the inspection result normal?

- YES >> GO TO 11.
- NO >> GO TO 7.

7.REPLACE ACCELERATOR PEDAL ASSEMBLY

1. Replace accelerator pedal assembly.
2. Go to [EC-381, "Special Repair Requirement"](#).

>> INSPECTION END

8.CHECK BATTERY CURRENT SENSOR GROUND CIRCUIT FOR OPEN AND SHORT

1. Turn ignition switch OFF.
2. Disconnect ECM harness connector.
3. Check the continuity between battery current sensor harness connector and ECM harness connector.

Battery current sensor		ECM		Continuity
Connector	Terminal	Connector	Terminal	
F53	2	F8	68	Existed

4. Also check harness for short to ground and short to power.

Is the inspection result normal?

- YES >> GO TO 9.
- NO >> Repair open circuit, short to ground or short to power in harness or connectors.

9.CHECK BATTERY CURRENT SENSOR INPUT SIGNAL CIRCUIT FOR OPEN AND SHORT

1. Check the continuity between battery current sensor harness connector and ECM harness connector.

Battery current sensor		ECM		Continuity
Connector	Terminal	Connector	Terminal	
F53	3	F8	58	Existed

2. Also check harness for short to ground and short to power.

Is the inspection result normal?

- YES >> GO TO 10.
- NO >> Repair open circuit, short to ground or short to power in harness or connectors.

10.CHECK BATTERY CURRENT SENSOR

Refer to [EC-340, "Component Inspection"](#).

Is the inspection result normal?

- YES >> GO TO 11.
- NO >> Replace battery negative cable assembly.

11.CHECK INTERMITTENT INCIDENT

Refer to [GI-34, "Intermittent Incident"](#).

>> INSPECTION END

Component Inspection

INFOID:000000005184779

1.CHECK BATTERY CURRENT SENSOR

P1553 BATTERY CURRENT SENSOR

[MR18DE]

< DTC/CIRCUIT DIAGNOSIS >

1. Turn ignition switch OFF.
2. Reconnect harness connectors disconnected.
3. Disconnect battery negative cable.
4. Install jumper cable (A) between battery negative terminal and body ground.

1 : Battery negative terminal

← : To body ground

5. Turn ignition switch ON.
6. Check the voltage between ECM harness connector and ground.

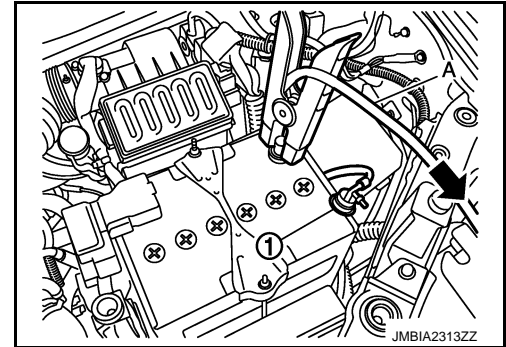

Connector	ECM		Voltage
	+	-	
F8	58 (Battery current sensor signal)	68	Approx. 2.5 V

Before measuring the terminal voltage, confirm that the battery is fully charged. Refer to [PG-3, "How to Handle Battery"](#).

Is the inspection result normal?

- YES >> INSPECTION END
NO >> Replace battery negative cable assembly.

P1554 BATTERY CURRENT SENSOR

< DTC/CIRCUIT DIAGNOSIS >

[MR18DE]

P1554 BATTERY CURRENT SENSOR

Description

INFOID:000000005184774

The power generation voltage variable control enables fuel consumption to be decreased by reducing the engine load which is caused by the power generation of the generator. The battery current sensor is installed to the battery cable at the negative terminal. The sensor measures the charging/discharging current of the battery. Based on the sensor signal, ECM judges whether or not the power generation voltage variable control is performed. When performing the power generation voltage variable control, ECM calculates the target power generation voltage based on the sensor signal. And ECM sends the calculated value as the power generation command value to IPDM E/R. For the details of the power generation voltage variable control, refer to [PCS-69. "System Description"](#).

CAUTION:

Never connect the electrical component or the ground wire directly to the battery terminal. The connection causes the malfunction of the power generation voltage variable control, and then the battery discharge may occur.

DTC Logic

INFOID:000000005151148

DTC DETECTION LOGIC

DTC No.	Trouble diagnosis name	DTC detecting condition	Possible cause
P1554	Battery current sensor performance	The output voltage of the battery current sensor is lower than the specified value while the battery voltage is high enough.	<ul style="list-style-type: none">• Harness or connectors (Battery current sensor circuit is open or shorted.) [Crankshaft position sensor (POS) circuit is shorted.] (Power steering pressure sensor circuit is shorted.) (Accelerator pedal position sensor circuit is shorted.) (Refrigerant pressure sensor circuit is shorted.)• Battery current sensor• Crankshaft position sensor (POS)• Power steering pressure sensor• Accelerator pedal position sensor• Refrigerant pressure sensor

DTC CONFIRMATION PROCEDURE

1. PERFORM COMPONENT FUNCTION CHECK

Perform component function check. Refer to [EC-337. "Component Function Check"](#).

NOTE:

Use component function check to check the overall function of the battery current sensor circuit. During this check, a 1st trip DTC might not be confirmed.

Is the inspection result normal?

YES >> INSPECTION END

NO >> Go to [EC-338. "Diagnosis Procedure"](#).

Component Function Check

INFOID:000000005151149

1. PRECONDITIONING

TESTING CONDITION:

- Before performing the following procedure, confirm that battery voltage is more than 12.8 V at idle.
- Before performing the following procedure, confirm that all load switches and A/C switch are turned OFF.

>> GO TO 2.

P1554 BATTERY CURRENT SENSOR

[MR18DE]

< DTC/CIRCUIT DIAGNOSIS >

2. PERFORM COMPONENT FUNCTION CHECK

① With CONSULT-III

1. Start engine and let it idle.
2. Select "BAT CUR SEN" in "DATA MONITOR" mode with CONSULT-III.
3. Check "BAT CUR SEN" indication for 10 seconds.
"BAT CUR SEN" should be above 2,300 mV at least once.

② Without CONSULT-III

1. Start engine and let it idle.
2. Check the voltage between ECM harness connector and ground.

Connector	ECM		Voltage
	+	-	
	Terminal	Terminal	
F8	58 (Battery current sensor signal)	68	Above 2.3 V at least once

Is the inspection result normal?

- YES >> INSPECTION END
NO >> Go to [EC-338, "Diagnosis Procedure"](#)

Diagnosis Procedure

INFOID:000000005184777

1. CHECK GROUND CONNECTION

1. Turn ignition switch OFF.
2. Check ground connection E38. Refer to Ground Inspection in [GI-37, "Circuit Inspection"](#).

Is the inspection result normal?

- YES >> GO TO 2.
NO >> Repair or replace ground connection.

2. CHECK BATTERY CURRENT SENSOR POWER SUPPLY CIRCUIT-I

1. Disconnect battery current sensor harness connector.
2. Turn ignition switch ON.
3. Check the voltage between battery current sensor harness connector and ground.

Battery current sensor		Ground	Voltage
Connector	Terminal		
F53	1	Ground	Approx. 5 V

Is the inspection result normal?

- YES >> GO TO 8.
NO >> GO TO 3.

3. CHECK BATTERY CURRENT SENSOR POWER SUPPLY CIRCUIT-II

1. Turn ignition switch OFF.
2. Disconnect ECM harness connector.
3. Check the continuity between battery current sensor harness connector and ECM harness connector.

Battery current sensor		ECM		Continuity
Connector	Terminal	Connector	Terminal	
F53	1	F8	77	Existed

Is the inspection result normal?

- YES >> GO TO 4.
NO >> Repair open circuit.

4. CHECK SENSOR POWER SUPPLY CIRCUIT

P1554 BATTERY CURRENT SENSOR

[MR18DE]

< DTC/CIRCUIT DIAGNOSIS >

Check harness for short to power and short to ground, between the following terminals.

ECM		Sensor		
Connector	Terminal	Name	Connector	Terminal
F8	74	Refrigerant pressure sensor	E49	1
	75	CKP sensor (POS)	F20	1
	76	EVAP control system pressure sensor	B21	3
	77	Battery current sensor	F53	1
E16	102	APP sensor	E110	5

Is the inspection result normal?

YES >> GO TO 5.

NO >> Repair short to ground or short to power in harness or connectors.

5. CHECK COMPONENTS

Check the following.

- Crankshaft position sensor (POS) (Refer to [EC-228, "Component Inspection"](#).)
- EVAP control system pressure sensor (Refer to [EC-269, "Component Inspection"](#).)
- Refrigerant pressure sensor (Refer to [EC-414, "Diagnosis Procedure"](#).)

Is the inspection result normal?

YES >> GO TO 6.

NO >> Replace malfunctioning components.

6. CHECK APP SENSOR

Refer to [EC-381, "Component Inspection"](#).

Is the inspection result normal?

YES >> GO TO 11.

NO >> GO TO 7.

7. REPLACE ACCELERATOR PEDAL ASSEMBLY

1. Replace accelerator pedal assembly.
2. Go to [EC-381, "Special Repair Requirement"](#).

>> INSPECTION END

8. CHECK BATTERY CURRENT SENSOR GROUND CIRCUIT FOR OPEN AND SHORT

1. Turn ignition switch OFF.
2. Disconnect ECM harness connector.
3. Check the continuity between battery current sensor harness connector and ECM harness connector.

Battery current sensor		ECM		Continuity
Connector	Terminal	Connector	Terminal	
F53	2	F8	68	Existed

4. Also check harness for short to ground and short to power.

Is the inspection result normal?

YES >> GO TO 9.

NO >> Repair open circuit, short to ground or short to power in harness or connectors.

9. CHECK BATTERY CURRENT SENSOR INPUT SIGNAL CIRCUIT FOR OPEN AND SHORT

1. Check the continuity between battery current sensor harness connector and ECM harness connector.

P1554 BATTERY CURRENT SENSOR

[MR18DE]

< DTC/CIRCUIT DIAGNOSIS >

Battery current sensor		ECM		Continuity
Connector	Terminal	Connector	Terminal	
F53	3	F8	58	Existed

2. Also check harness for short to ground and short to power.

Is the inspection result normal?

YES >> GO TO 10.

NO >> Repair open circuit, short to ground or short to power in harness or connectors.

10.CHECK BATTERY CURRENT SENSOR

Refer to [EC-340, "Component Inspection"](#).

Is the inspection result normal?

YES >> GO TO 11.

NO >> Replace battery negative cable assembly.

11.CHECK INTERMITTENT INCIDENT

Refer to [GI-34, "Intermittent Incident"](#).

>> INSPECTION END

Component Inspection

INFOID:000000005184780

1.CHECK BATTERY CURRENT SENSOR

1. Turn ignition switch OFF.
2. Reconnect harness connectors disconnected.
3. Disconnect battery negative cable.
4. Install jumper cable (A) between battery negative terminal and body ground.

1 : Battery negative terminal

← : To body ground

5. Turn ignition switch ON.
6. Check the voltage between ECM harness connector and ground.

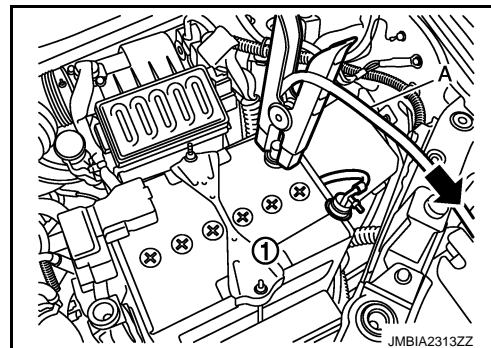

Connector	ECM		Voltage
	+	-	
	Terminal	Terminal	
F8	58 (Battery current sensor signal)	68	Approx. 2.5 V

Before measuring the terminal voltage, confirm that the battery is fully charged. Refer to [PG-3, "How to Handle Battery"](#).

Is the inspection result normal?

YES >> INSPECTION END

NO >> Replace battery negative cable assembly.

P1564 ASCD STEERING SWITCH

< DTC/CIRCUIT DIAGNOSIS >

[MR18DE]

P1564 ASCD STEERING SWITCH

Description

INFOID:000000005040369

ASCD steering switch has variant values of electrical resistance for each button. ECM reads voltage variation of switch, and determines which button is operated. Refer to [EC-51, "System Description"](#) for the ASCD function.

DTC Logic

INFOID:000000005040370

DTC DETECTION LOGIC

NOTE:

If DTC P1564 is displayed with DTC P0605, first perform the trouble diagnosis for DTC P0605. Refer to [EC-305, "DTC Logic"](#).

DTC No.	Trouble diagnosis name	DTC detecting condition	Possible cause
P1564	ASCD steering switch	<ul style="list-style-type: none">An excessively high voltage signal from the ASCD steering switch is sent to ECM.ECM detects that input signal from the ASCD steering switch is out of the specified range.ECM detects that the ASCD steering switch is stuck ON.	<ul style="list-style-type: none">Harness or connectors (The switch circuit is open or shorted.)ASCD steering switchECM

DTC CONFIRMATION PROCEDURE

1. PRECONDITIONING

If DTC Confirmation Procedure has been previously conducted, always turn ignition switch OFF and wait at least 10 seconds before conducting the next test.

>> GO TO 2.

2. PERFORM DTC CONFIRMATION PROCEDURE

- Turn ignition switch ON.
- Wait at least 10 seconds.
- Press MAIN switch for at least 10 seconds, then release it and wait at least 10 seconds.
- Press CANCEL switch for at least 10 seconds, then release it and wait at least 10 seconds.
- Press RESUME/ACCELERATE switch for at least 10 seconds, then release it and wait at least 10 seconds.
- Press SET/COAST switch for at least 10 seconds, then release it and wait at least 10 seconds.
- Check DTC.

Is DTC detected?

- YES >> Go to [EC-341, "Diagnosis Procedure"](#).
NO >> INSPECTION END

Diagnosis Procedure

INFOID:000000005040371

1. CHECK GROUND CONNECTION

- Turn ignition switch OFF.
- Check ground connection E38. Refer to Ground Inspection in [GI-37, "Circuit Inspection"](#).

Is the inspection result normal?

- YES >> GO TO 2.
NO >> Repair or replace ground connection.

2. CHECK ASCD STEERING SWITCH CIRCUIT

Ⓜ With CONSULT-III

- Turn ignition switch ON.

P1564 ASCD STEERING SWITCH

[MR18DE]

< DTC/CIRCUIT DIAGNOSIS >

- Select "MAIN SW", "CANCEL SW", "RESUME/ACC SW" and "SET SW" in "DATA MONITOR" mode with CONSULT-III.
- Check each item indication under the following conditions.

Monitor item	Condition		Indication
MAIN SW	MAIN switch	Pressed	ON
		Released	OFF
CANCEL SW	CANCEL switch	Pressed	ON
		Released	OFF
RESUME/ACC SW	RESUME/ACCELERATE switch	Pressed	ON
		Released	OFF
SET SW	SET/COAST switch	Pressed	ON
		Released	OFF

⊗ Without CONSULT-III

- Turn ignition switch ON.
- Check the voltage between ECM harness connector terminals.

ECM			Condition	Voltage
Connector	+	-		
	Terminal	Terminal		
E16	94 (ASCD steering switch signal)	95	MAIN switch: Pressed	Approx. 0V
			CANSEL switch: Pressed	Approx. 1V
			SET/COAST switch: Pressed	Approx. 2V
			RESUME/ACCELERATE switch: Pressed	Approx. 3V
			All ASCD steering switches: Re- leased	Approx. 4V

Is the inspection result normal?

YES >> GO TO 8.

NO >> GO TO 3.

3. CHECK ASCD STEERING SWITCH GROUND CIRCUIT FOR OPEN AND SHORT

- Turn ignition switch OFF.
- Disconnect ECM harness connector.
- Disconnect combination switch harness connector M352.
- Check the continuity between combination switch and ECM harness connector.

Combination switch	ECM		Continuity
	Connector	Terminal	
Terminal			
16	E16	95	Existed

- Also check harness for short to ground and short to power.

Is the inspection result normal?

YES >> GO TO 5.

NO >> GO TO 4.

4. DETECT MALFUNCTIONING PART

Check the following.

- Harness connectors M77, E105
- Combination switch (spiral cable)
- Harness for open and short between ECM and combination switch

P1564 ASCD STEERING SWITCH

[MR18DE]

< DTC/CIRCUIT DIAGNOSIS >

>> Repair open circuit or short to ground or short to power in harness or connectors.

5. CHECK ASCD STEERING SWITCH INPUT SIGNAL CIRCUIT FOR OPEN AND SHORT

1. Check the continuity between ECM harness connector and combination switch.

combination switch	ECM		Continuity
	Terminal	Connector	
13	E16	94	Existed

2. Also check harness for short to ground and short to power.

Is the inspection result normal?

YES >> GO TO 7.

NO >> GO TO 6.

6. DETECT MALFUNCTIONING PART

Check the following.

- Harness connectors M77, E105
- Combination switch (spiral cable)
- Harness for open and short between ECM and combination switch

>> Repair open circuit or short to ground or short to power in harness or connectors.

7. CHECK ASCD STEERING SWITCH

Refer to [EC-343. "Component Inspection"](#).

Is the inspection result normal?

YES >> GO TO 8.

NO >> Replace ASCD steering switch.

8. CHECK INTERMITTENT INCIDENT

Refer to [GI-34. "Intermittent Incident"](#).

>> INSPECTION END

Component Inspection

INFOID:000000005040372

1. CHECK ASCD STEERING SWITCH

1. Disconnect combination switch (spiral cable) harness connector.
2. Check the continuity between combination switch harness connector terminals under following conditions.

Combination switch		Condition	Resistance
Connector	Terminals		
M302	13 and 16	MAIN switch: Pressed	Approx. 0 Ω
		CANCEL switch: Pressed	Approx. 250 Ω
		SET/COAST switch: Pressed	Approx. 660 Ω
		RESUME/ACCELERATE switch: Pressed	Approx. 1,480 Ω
		All ASCD steering switches: Released	Approx. 4,000 Ω

Is the inspection result normal?

YES >> INSPECTION END

NO >> Replace ASCD steering switch

P1572 ASCD BRAKE SWITCH

< DTC/CIRCUIT DIAGNOSIS >

[MR18DE]

P1572 ASCD BRAKE SWITCH

Description

INFOID:000000005040373

When the brake pedal is depressed, ASCD brake switch is turned OFF and stop lamp switch is turned ON. ECM detects the state of the brake pedal by this input of two kinds (ON/OFF signal). Refer to [EC-51, "System Description"](#) for the ASCD function.

DTC Logic

INFOID:000000005040374

DTC DETECTION LOGIC

NOTE:

- If DTC P1572 is displayed with DTC P0605, first perform the trouble diagnosis for DTC P0605. Refer to [EC-305, "DTC Logic"](#).
- This self-diagnosis has the one trip detection logic. When malfunction A is detected, DTC is not stored in ECM memory. And in that case, 1st trip DTC and 1st trip freeze frame data are displayed. 1st trip DTC is erased when ignition switch OFF. And even when malfunction A is detected in two consecutive trips, DTC is not stored in ECM memory.

DTC No.	Trouble diagnosis name	DTC detecting condition		Possible cause
P1572	ASCD brake switch	A)	When the vehicle speed is above 30 km/h (19 MPH), ON signals from the stop lamp switch and the ASCD brake switch are sent to the ECM at the same time.	<ul style="list-style-type: none">• Harness or connectors (The stop lamp switch circuit is shorted.)• Harness or connectors (The ASCD brake switch circuit is shorted.)• Harness or connectors (The ASCD clutch switch circuit is shorted.)• Stop lamp switch• ASCD brake switch• ASCD clutch switch• Incorrect stop lamp switch installation• Incorrect ASCD brake switch installation• Incorrect ASCD clutch switch installation• ECM
		B)	ASCD brake switch signal is not sent to ECM for extremely long time while the vehicle is driving.	

DTC CONFIRMATION PROCEDURE

1. PRECONDITIONING

If DTC Confirmation Procedure has been previously conducted, always turn ignition switch OFF and wait at least 10 seconds before conducting the next test.

NOTE:

Procedure for malfunction B is not described here. It takes extremely long time to complete procedure for malfunction B. By performing procedure for malfunction A, the incident that causes malfunction B can be detected.

>> GO TO 2.

2. PERFORM DTC CONFIRMATION PROCEDURE FOR MALFUNCTION A

1. Start engine.
2. Press MAIN switch and make sure that CRUISE indicator is displayed in combination meter.
3. Drive the vehicle for at least 5 consecutive seconds under the following conditions.

CAUTION:

Always drive vehicle at a safe speed.

NOTE:

This procedure may be conducted with the drive wheels lifted in the shop or by driving the vehicle. If a road test is expected to be easier, it is unnecessary to lift the vehicle.

Vehicle speed	More than 30 km/h (19 mph)
Selector lever	Suitable position

4. Check DTC.

P1572 ASCD BRAKE SWITCH

[MR18DE]

< DTC/CIRCUIT DIAGNOSIS >

Is DTC detected?

- YES >> Go to [EC-345, "Diagnosis Procedure"](#).
- NO >> GO TO 3.

3.PERFORM DTC CONFIRMATION PROCEDURE FOR MALFUNCTION B

1. Drive the vehicle for at least 5 consecutive seconds under the following conditions.

CAUTION:

Always drive vehicle at a safe speed.

NOTE:

This procedure may be conducted with the drive wheels lifted in the shop or by driving the vehicle. If a road test is expected to be easier, it is unnecessary to lift the vehicle.

Vehicle speed	More than 30 km/h (19 mph)
Selector lever	Suitable position
Driving location	Depress the brake pedal for more than five seconds so as not to come off from the above-mentioned vehicle speed.

2. Check DTC.

Is DTC detected?

- YES >> Go to [EC-345, "Diagnosis Procedure"](#).
- NO >> INSPECTION END

Diagnosis Procedure

INFOID:000000005040375

1.CHECK OVERALL FUNCTION-I

 **With CONSULT-III**

1. Turn ignition switch ON.
2. Select "BRAKE SW1" in "DATA MONITOR" mode with CONSULT-III.
3. Check "BRAKE SW1" indication under the following conditions.

Monitor item	Condition		Indication
BRAKE SW1	Brake pedal (CVT)	Slightly depressed	OFF
	Brake pedal and clutch pedal (M/T)	Fully released	ON

 **Without CONSULT-III**

1. Turn ignition switch ON.
2. Check the voltage between ECM harness connector terminals.

Connector	ECM		Condition	Voltage	
	+	-			
	Terminal	Terminal			
E16	100 (ASCD brake switch signal)	108	Brake pedal (CVT)	Slightly depressed	Approx. 0V
			Brake pedal and clutch pedal (M/T)	Fully released	Battery voltage

Is the inspection result normal?

- YES >> GO TO 2.
- NO >> GO TO 3.

2.CHECK OVERALL FUNCTION-II

 **With CONSULT-III**

Select "BRAKE SW2" and check indication in "DATA MONITOR" mode with CONSULT-III.

P1572 ASCD BRAKE SWITCH

[MR18DE]

< DTC/CIRCUIT DIAGNOSIS >

Monitor item	Condition		Indication
BRAKE SW2	Brake pedal	Slightly depressed	ON
		Fully released	OFF

⊗ Without CONSULT-III

Check the voltage between ECM harness connector terminals.

ECM			Condition	Voltage	
Connector	+	-			
		Terminal	Terminal		
E16	99 (Stop lamp switch signal)	108	Brake pedal	Slightly depressed	Battery voltage
			Fully released	Approx. 0V	

Is the inspection result normal?

- YES >> GO TO 16.
NO >> GO TO 11.

3. CHECK ASCD BRAKE SWITCH POWER SUPPLY CIRCUIT-I

- Turn ignition switch OFF.
- Disconnect ASCD brake switch harness connector.
- Turn ignition switch ON.
- Check the voltage between ASCD brake switch harness connector and ground.

ASCD brake switch		Ground	Voltage
Connector	Terminal		
E112	1	Ground	Battery voltage

Is the inspection result normal?

- YES >> GO TO 9.
NO-1 >> CVT models: GO TO 4.
NO-2 >> M/T models: GO TO 5.

4. DETECT MALFUNCTIONING PART

Check the following.

- Harness connectors E105, M77
- 10 A fuse (No. 2)
- Harness for open or short between ASCD brake switch and fuse

>> Repair open circuit or short to ground or short to power in harness or connectors.

5. CHECK ASCD CLUTCH SWITCH POWER SUPPLY CIRCUIT

- Turn ignition switch OFF.
- Disconnect ASCD clutch switch harness connector.
- Turn ignition switch ON.
- Check the voltage between ASCD clutch switch harness connector and ground.

ASCD clutch switch		Ground	Voltage
Connector	Terminal		
E111	3	Ground	Battery voltage

Is the inspection result normal?

- YES >> GO TO 7.
NO >> GO TO 6.

P1572 ASCD BRAKE SWITCH

[MR18DE]

< DTC/CIRCUIT DIAGNOSIS >

6. DETECT MALFUNCTIONING PART

Check the following.

- Harness connectors E105, M77
- 10 A fuse (No. 2)
- Harness for open or short between ASCD clutch switch and fuse

>> Repair open circuit or short to ground or short to power in harness or connectors.

7. CHECK ASCD BRAKE SWITCH POWER SUPPLY CIRCUIT-II

1. Turn ignition switch OFF.
2. Disconnect ASCD brake switch harness connector.
3. Check the continuity between ASCD clutch switch harness connector and ASCD brake switch harness connector.

ASCD clutch switch		ASCD brake switch		Continuity
Connector	Terminal	Connector	Terminal	
E111	4	E112	1	Existed

4. Also check harness for short to ground and short to power.

Is the inspection result normal?

YES >> GO TO 8.

NO >> Repair open circuit or short to ground or short to power in harness or connectors.

8. CHECK ASCD CLUTCH SWITCH

Refer to [EC-349. "Component Inspection \(ASCD Clutch Switch\)".](#)

Is the inspection result normal?

YES >> GO TO 16.

NO >> Replace ASCD clutch switch.

9. CHECK ASCD BRAKE SWITCH INPUT SIGNAL CIRCUIT FOR OPEN AND SHORT

1. Turn ignition switch OFF.
2. Disconnect ECM harness connector.
3. Check the continuity between ASCD brake switch harness connector and ECM harness connector.

ASCD brake switch		ECM		Continuity
Connector	Terminal	Connector	Terminal	
E112	2	E16	100	Existed

4. Also check harness for short to ground and short to power.

Is the inspection result normal?

YES >> GO TO 10.

NO >> Repair open circuit or short to ground or short to power in harness or connectors.

10. CHECK ASCD BRAKE SWITCH

Refer to [EC-348. "Component Inspection \(ASCD Brake Switch\)".](#)

Is the inspection result normal?

YES >> GO TO 16.

NO >> Replace ASCD brake switch.

11. CHECK STOP LAMP SWITCH POWER SUPPLY CIRCUIT

1. Turn ignition switch OFF.
2. Disconnect stop lamp switch harness connector.
3. Check the voltage between stop lamp switch harness connector and ground.

P1572 ASCD BRAKE SWITCH

[MR18DE]

< DTC/CIRCUIT DIAGNOSIS >

Stop lamp switch		Ground	Voltage
Connector	Terminal		
E114 (M/T) E115 (CVT)	1	Ground	Battery voltage

Is the inspection result normal?

YES >> GO TO 13.

NO >> GO TO 12.

12.DETECT MALFUNCTIONING PART

Check the following.

- Harness connectors E105, M77
- 10A fuse (No.11)
- Harness for open or short between stop lamp switch and battery

>> Repair open circuit or short to ground or short to power in harness or connectors.

13.CHECK STOP LAMP SWITCH INPUT SIGNAL CIRCUIT FOR OPEN AND SHORT

1. Disconnect ECM harness connector.
2. Check the continuity between ECM harness connector and stop lamp switch harness connector.

ECM		Stop lamp switch		Continuity
Connector	Terminal	Connector	Terminal	
E16	99	E114 (M/T) E115 (CVT)	2	Existed

3. Also check harness for short to ground and short to power.

Is the inspection result normal?

YES >> GO TO 15.

NG >> GO TO 14.

14.DETECT MALFUNCTIONING PART

Check the following.

- Harness for open or short between ECM and stop lamp switch

>> Repair open circuit or short to ground or short to power in harness or connectors.

15.CHECK STOP LAMP SWITCH

Refer to [EC-349, "Component Inspection \(Stop Lamp Switch\)"](#).

Is the inspection result normal?

YES >> GO TO 16.

NO >> Replace stop lamp switch.

16.CHECK INTERMITTENT INCIDENT

Refer to [GI-34, "Intermittent Incident"](#).

>> INSPECTION END

Component Inspection (ASCD Brake Switch)

INFOID:000000005040376

1.CHECK ASCD BRAKE SWITCH-I

1. Turn ignition switch OFF.
2. Disconnect ASCD brake switch harness connector.
3. Check the continuity between ASCD brake switch terminals under the following conditions.

P1572 ASCD BRAKE SWITCH

< DTC/CIRCUIT DIAGNOSIS >

[MR18DE]

Terminals	Condition		Continuity
1 and 2	Brake pedal	Fully released	Existed
		Slightly depressed	Not existed

Is the inspection result normal?

YES >> INSPECTION END

NO >> GO TO 2.

2.CHECK ASCD BRAKE SWITCH-II

1. Adjust ASCD brake switch installation. Refer to [BR-7, "Inspection and Adjustment"](#).
2. Check the continuity between ASCD brake switch terminals under the following conditions.

Terminals	Condition		Continuity
1 and 2	Brake pedal	Fully released	Existed
		Slightly depressed	Not existed

Is the inspection result normal?

YES >> INSPECTION END

NO >> Replace ASCD brake switch.

Component Inspection (ASCD Clutch Switch)

INFOID:000000005040377

1.CHECK ASCD CLUTCH SWITCH-I

1. Turn ignition switch OFF.
2. Disconnect ASCD clutch switch harness connector.
3. Check the continuity between ASCD clutch switch terminals under the following conditions.

Terminals	Condition		Continuity
1 and 2	Clutch pedal	Fully released	Existed
		Slightly depressed	Not existed

Is the inspection result normal?

YES >> INSPECTION END

NO >> GO TO 2.

2.CHECK ASCD CLUTCH SWITCH-II

1. Adjust ASCD clutch switch installation. Refer to [BR-7, "Inspection and Adjustment"](#).
2. Check the continuity between ASCD clutch switch terminals under the following conditions.

Terminals	Condition		Continuity
1 and 2	Clutch pedal	Fully released	Existed
		Slightly depressed	Not existed

Is the inspection result normal?

YES >> INSPECTION END

NO >> Replace ASCD clutch switch.

Component Inspection (Stop Lamp Switch)

INFOID:000000005040378

1.CHECK STOP LAMP SWITCH-I

1. Turn ignition switch OFF.
2. Disconnect stop lamp switch harness connector.
3. Check the continuity between stop lamp switch terminals under the following conditions.

P1572 ASCD BRAKE SWITCH

[MR18DE]

< DTC/CIRCUIT DIAGNOSIS >

Terminals	Condition		Continuity
1 and 2	Brake pedal	Fully released	Not existed
		Slightly de-pressed	Existed

Is the inspection result normal?

YES >> INSPECTION END

NO >> GO TO 2.

2. CHECK STOP LAMP SWITCH-II

1. Adjust stop lamp switch installation. Refer to [BR-7, "Inspection and Adjustment"](#).
2. Check the continuity between stop lamp switch terminals under the following conditions.

Terminals	Condition		Continuity
1 and 2	Brake pedal	Fully released	Not existed
		Slightly de-pressed	Existed

Is the inspection result normal?

YES >> INSPECTION END

NO >> Replace stop lamp switch.

P1574 ASCD VEHICLE SPEED SENSOR

[MR18DE]

< DTC/CIRCUIT DIAGNOSIS >

P1574 ASCD VEHICLE SPEED SENSOR

Description

INFOID:000000005040379

The ECM receives two vehicle speed sensor signals via CAN communication line. One is sent from combination meter, and the other is from TCM (Transmission control module). The ECM uses these signals for ASCD control. Refer to [EC-51, "System Description"](#) for ASCD functions.

DTC Logic

INFOID:000000005040380

DTC DETECTION LOGIC

NOTE:

- If DTC P1574 is displayed with DTC U1001, first perform the trouble diagnosis for DTC U1001. Refer to [EC-122, "DTC Logic"](#).
- If DTC P1574 is displayed with DTC P0500, first perform the trouble diagnosis for DTC P0500. Refer to [EC-299, "DTC Logic"](#).
- If DTC P1574 is displayed with DTC P0605, first perform the trouble diagnosis for DTC P0605. Refer to [EC-305, "DTC Logic"](#).
- If DTC P1574 is displayed with DTC P0607, first perform the trouble diagnosis for DTC P0607. Refer to [EC-307, "DTC Logic"](#).

DTC No.	Trouble diagnosis name	DTC detecting condition	Possible cause
P1574	ASCD vehicle speed sensor	ECM detects a difference between two vehicle speed signals is out of the specified range.	<ul style="list-style-type: none">• Harness or connectors (The CAN communication line is open or shorted.)• ABS actuator and electric unit (control unit)• TCM• ECM

DTC CONFIRMATION PROCEDURE

1. PRECONDITIONING

If DTC Confirmation Procedure has been previously conducted, always turn ignition switch OFF and wait at least 10 seconds before conducting the next test.

>> GO TO 2.

2. PERFORM DTC CONFIRMATION PROCEDURE

1. Start engine.
2. Drive the vehicle at more than 40 km/h (25 MPH).

CAUTION:

Always drive vehicle at a safe speed.

NOTE:

This procedure may be conducted with the drive wheels lifted in the shop or by driving the vehicle. If a road test is expected to be easier, it is unnecessary to lift the vehicle.

3. Check DTC.

Is DTC detected?

YES >> Go to [EC-351, "Diagnosis Procedure"](#).

NO >> INSPECTION END

Diagnosis Procedure

INFOID:000000005040381

1. CHECK DTC WITH TCM

Check DTC with TCM. Refer to [TM-91, "Diagnosis Description"](#).

Is DTC detected?

NO >> GO TO 2.

YES >> Perform trouble shooting relevant to DTC indicated.

P1574 ASCD VEHICLE SPEED SENSOR

< DTC/CIRCUIT DIAGNOSIS >

[MR18DE]

2. CHECK DTC WITH "ABS ACTUATOR AND ELECTRIC UNIT (CONTROL UNIT)"

Refer to [BRC-22. "CONSULT-III Function"](#).

Is DTC detected?

NO >> INSPECTION END

YES >> Perform trouble shooting relevant to DTC indicated.

P1715 INPUT SPEED SENSOR

< DTC/CIRCUIT DIAGNOSIS >

[MR18DE]

P1715 INPUT SPEED SENSOR

Description

INFOID:000000004833451

ECM receives input speed sensor signal from TCM via the CAN communication line. ECM uses this signal for engine control.

DTC Logic

INFOID:000000004833452

DTC DETECTION LOGIC

NOTE:

- If DTC P1715 is displayed with DTC UXXXX, first perform the trouble diagnosis for DTC UXXXX.
- If DTC P1715 is displayed with DTC P0335, first perform the trouble diagnosis for DTC P0335. Refer to [EC-225, "DTC Logic"](#).
- If DTC P1715 is displayed with DTC P0340, first perform the trouble diagnosis for DTC P0340. Refer to [EC-229, "DTC Logic"](#).
- If DTC P1715 is displayed with DTC P0605, first perform the trouble diagnosis for DTC P0605. Refer to [EC-305, "DTC Logic"](#).
- If DTC P1715 is displayed with DTC P0607, first perform the trouble diagnosis for DTC P0607. Refer to [EC-307, "DTC Logic"](#).

DTC No.	Trouble diagnosis name	DTC detecting condition	Possible cause
P1715	Input speed sensor (TCM output)	Input speed sensor signal is different from the theoretical value calculated by ECM from output speed sensor signal and engine rpm signal.	<ul style="list-style-type: none">• Harness or connectors (The CAN communication line is open or shorted)• Harness or connectors (Input speed sensor circuit is open or shorted)• TCM

DTC CONFIRMATION PROCEDURE

1. PRECONDITIONING

If DTC Confirmation Procedure has been previously conducted, always turn ignition switch OFF and wait at least 10 seconds before conducting the next test.

>> GO TO 2.

2. PERFORM DTC CONFIRMATION PROCEDURE

1. Start engine and drive the vehicle at more than 50 km/h (31 MPH) for at least 5 seconds.

CAUTION:

Always drive vehicle at a safe speed.

2. Check 1st trip DTC.

Is 1st trip DTC detected?

YES >> Go to [EC-353, "Diagnosis Procedure"](#).

NO >> INSPECTION END

Diagnosis Procedure

INFOID:000000004833453

1. CHECK DTC WITH TCM

Check DTC with TCM. Refer to [TM-92, "CONSULT-III Function \(TRANSMISSION\)"](#).

Is the inspection result normal?

YES >> GO TO 2.

NO >> Perform trouble shooting relevant to DTC indicated.

2. REPLACE TCM

Replace TCM.

>> INSPECTION END

P1805 BRAKE SWITCH

< DTC/CIRCUIT DIAGNOSIS >

[MR18DE]

P1805 BRAKE SWITCH

Description

INFOID:000000004833454

Brake switch signal is applied to the ECM through the stop lamp switch when the brake pedal is depressed. This signal is used mainly to decrease the engine speed when the vehicle is driving.

DTC Logic

INFOID:000000004833455

DTC DETECTION LOGIC

DTC No.	Trouble diagnosis name	DTC detecting condition	Possible cause
P1805	Brake switch	A brake switch signal is not sent to ECM for extremely long time while the vehicle is driving.	<ul style="list-style-type: none">• Harness or connectors (Stop lamp switch circuit is open or shorted.)• Stop lamp switch

DTC CONFIRMATION PROCEDURE

1. PERFORM DTC CONFIRMATION PROCEDURE

1. Turn ignition switch ON.
2. Fully depress the brake pedal for at least 5 seconds.
3. Erase the DTC.
4. Check 1st trip DTC.

Is 1st trip DTC detected?

- YES >> Go to [EC-354, "Diagnosis Procedure"](#).
NO >> INSPECTION END

Diagnosis Procedure

INFOID:000000004833457

1. CHECK STOP LAMP SWITCH CIRCUIT

1. Turn ignition switch OFF.
2. Check the stop lamp when depressing and releasing the brake pedal.

Brake pedal	Stop lamp
Fully released	Not illuminated
Slightly depressed	Illuminated

Is the inspection result normal?

- YES >> GO TO 4.
NO >> GO TO 2.

2. CHECK STOP LAMP SWITCH POWER SUPPLY CIRCUIT

1. Turn ignition switch OFF.
2. Disconnect stop lamp switch harness connector.
3. Check the voltage between stop lamp switch harness connector and ground.

Stop lamp switch		Ground	Voltage
Connector	Terminal		
E114 (M/T) E115 (CVT)	1	Ground	Battery voltage

Is the inspection result normal?

- YES >> GO TO 4.
NO >> GO TO 3.

3. DETECT MALFUNCTIONING PART

Check the following.

P1805 BRAKE SWITCH

[MR18DE]

< DTC/CIRCUIT DIAGNOSIS >

- Harness connectors E7, M69
- 10 A fuse (No. 7)
- Harness for open or short between stop lamp switch and battery

>> Repair open circuit or short to ground or short to power in harness or connectors.

4.CHECK STOP LAMP SWITCH INPUT SIGNAL CIRCUIT FOR OPEN AND SHORT

1. Disconnect ECM harness connector.
2. Check the continuity between ECM harness connector and stop lamp switch harness connector.

ECM		Stop lamp switch		Continuity
Connector	Terminal	Connector	Terminal	
E16	99	E114 (M/T) E115 (CVT)	2	Existed

3. Also check harness for short to ground and short to power.

Is the inspection result normal?

YES >> GO TO 5.

NO >> Repair open circuit or short to ground or short to power in harness or connectors.

5.CHECK STOP LAMP SWITCH

Refer to [EC-355. "Component Inspection \(Stop Lamp Switch\)".](#)

Is the inspection result normal?

YES >> GO TO 6.

NO >> Replace stop lamp switch.

6.CHECK INTERMITTENT INCIDENT

Refer to [GI-34. "Intermittent Incident".](#)

>> INSPECTION END

Component Inspection (Stop Lamp Switch)

INFOID:000000004833458

1.CHECK STOP LAMP SWITCH-I

1. Turn ignition switch OFF.
2. Disconnect stop lamp switch harness connector.
3. Check the continuity between stop lamp switch terminals under the following conditions.

Terminals	Condition		Continuity
1 and 2	Brake pedal	Fully released	Not existed
		Slightly depressed	Existed

Is the inspection result normal?

YES >> INSPECTION END

NO >> GO TO 2.

2.CHECK STOP LAMP SWITCH-II

1. Adjust stop lamp switch installation. Refer to [BR-7. "Inspection and Adjustment".](#)
2. Check the continuity between stop lamp switch terminals under the following conditions.

Terminals	Condition		Continuity
1 and 2	Brake pedal	Fully released	Not existed
		Slightly depressed	Existed

Is the inspection result normal?

P1805 BRAKE SWITCH

< DTC/CIRCUIT DIAGNOSIS >

[MR18DE]

YES >> INSPECTION END
NO >> Replace stop lamp switch.

P2100, P2103 THROTTLE CONTROL MOTOR RELAY

< DTC/CIRCUIT DIAGNOSIS >

[MR18DE]

P2100, P2103 THROTTLE CONTROL MOTOR RELAY

Description

INFOID:000000004833459

Power supply for the throttle control motor is provided to the ECM via throttle control motor relay. The throttle control motor relay is ON/OFF controlled by the ECM. When the ignition switch is turned ON, the ECM sends an ON signal to throttle control motor relay and battery voltage is provided to the ECM. When the ignition switch is turned OFF, the ECM sends an OFF signal to throttle control motor relay and battery voltage is not provided to the ECM.

DTC Logic

INFOID:000000004833460

DTC DETECTION LOGIC

DTC No.	Trouble diagnosis name	DTC detecting condition	Possible cause
P2100	Throttle control motor relay circuit open	ECM detects a voltage of power source for throttle control motor is excessively low.	<ul style="list-style-type: none">• Harness or connectors (Throttle control motor relay circuit is open)• Throttle control motor relay
P2103	Throttle control motor relay circuit short	ECM detect the throttle control motor relay is stuck ON.	<ul style="list-style-type: none">• Harness or connectors (Throttle control motor relay circuit is shorted)• Throttle control motor relay

DTC CONFIRMATION PROCEDURE

1. PRECONDITIONING

If DTC Confirmation Procedure has been previously conducted, always turn ignition switch OFF and wait at least 10 seconds before conducting the next test.

TESTING CONDITION:

Before performing the following procedure, confirm that battery voltage is more than 8 V.

With DTC is detected?

P2100 >> GO TO 2.

P2103 >> GO TO 3.

2. PERFORM DTC CONFIRMATION PROCEDURE FOR DTC P2100

1. Turn ignition switch ON and wait at least 2 seconds.
2. Start engine and let it idle for 5 seconds.
3. Check DTC.

Is DTC detected?

YES >> Go to [EC-357. "Diagnosis Procedure"](#).

NO >> INSPECTION END

3. PERFORM DTC CONFIRMATION PROCEDURE FOR DTC P2103

1. Turn ignition switch ON and wait at least 1 second.
2. Check DTC.

Is DTC detected?

YES >> Go to [EC-357. "Diagnosis Procedure"](#).

NO >> INSPECTION END

Diagnosis Procedure

INFOID:000000004833462

1. CHECK THROTTLE CONTROL MOTOR RELAY POWER SUPPLY CIRCUIT-I

1. Turn ignition switch OFF.
2. Check the voltage between ECM harness connector and ground.

P2100, P2103 THROTTLE CONTROL MOTOR RELAY

[MR18DE]

< DTC/CIRCUIT DIAGNOSIS >

ECM		Ground	Voltage
Connector	Terminal		
F7	15	Ground	Battery voltage

OK or NG

- OK >> GO TO 5.
NG >> GO TO 2.

2.CHECK THROTTLE CONTROL MOTOR RELAY POWER SUPPLY CIRCUIT-II

1. Disconnect ECM harness connector.
2. Disconnect IPDM E/R harness connector.
3. Check the continuity between ECM harness connector and IPDM E/R harness connector.

ECM		IPDM E/R		Continuity
Connector	Terminal	Connector	Terminal	
F7	15	E15	57	Existed

4. Also check harness for short to ground and short to power.

Is the inspection result normal?

- YES >> GO TO 4.
NO >> GO TO 3.

3.DETECT MALFUNCTIONING PART

Check the following.

- Harness connectors E8, F1
- Harness for open or short between ECM and IPDM E/R

>> Repair open circuit or short to ground or short to power in harness or connectors.

4.CHECK FUSE

1. Disconnect 15 A fuse (No. 64) from IPDM E/R.
2. Check 15 A fuse for blown.

Is the inspection result normal?

- YES >> GO TO 8.
NO >> Replace 15 A fuse.

5.CHECK THROTTLE CONTROL MOTOR RELAY INPUT SIGNAL CIRCUIT-I

Check the voltage between ECM harness connector and ground under the following conditions.

ECM		Ground	Condition	Voltage
Connector	Terminal			
F7	2	Ground	Ignition switch: OFF	Approximately 0 V
			Ignition switch: ON	Battery voltage

OK or NG

- OK >> GO TO 8.
NG >> GO TO 6.

6.CHECK THROTTLE CONTROL MOTOR RELAY INPUT SIGNAL CIRCUIT-II

1. Turn ignition switch OFF.
2. Disconnect ECM harness connector.
3. Disconnect IPDM E/R harness connector.
4. Check the continuity between ECM harness connector and IPDM E/R harness connector.

P2100, P2103 THROTTLE CONTROL MOTOR RELAY

< DTC/CIRCUIT DIAGNOSIS >

[MR18DE]

ECM		IPDM E/R		Continuity
Connector	Terminal	Connector	Terminal	
F7	2	E15	54	Existed

5. Also check harness for short to ground and short to power.

Is the inspection result normal?

- YES >> GO TO 8.
- NO >> GO TO 7.

7. DETECT MALFUNCTIONING PART

Check the following.

- Harness connectors E8, F1
- Harness for open or short between ECM and IPDM E/R

>> Repair open circuit or short to ground or short to power in harness or connectors.

8. CHECK INTERMITTENT INCIDENT

Refer to [GI-34, "Intermittent Incident"](#).

Is the inspection result normal?

- YES >> Replace IPDM E/R.
- NO >> Repair or replace harness or connectors.

A

EC

C

D

E

F

G

H

I

J

K

L

M

N

O

P

P2101 ELECTRIC THROTTLE CONTROL FUNCTION

< DTC/CIRCUIT DIAGNOSIS >

[MR18DE]

P2101 ELECTRIC THROTTLE CONTROL FUNCTION

Description

INFOID:000000004833463

Electric throttle control actuator consists of throttle control motor, throttle position sensor, etc. The throttle control motor is operated by the ECM and it opens and closes the throttle valve. The current opening angle of the throttle valve is detected by the throttle position sensor and it provides feedback to the ECM. ECM controls the throttle valve opening angle in response to driving condition via the throttle control motor.

DTC Logic

INFOID:000000004833464

DTC DETECTION LOGIC

NOTE:

- If DTC P2101 is displayed with DTC P2100, first perform the trouble diagnosis for DTC P2100. Refer to [EC-357, "DTC Logic"](#).
- If DTC P2101 is displayed with DTC P2119, first perform the trouble diagnosis for DTC P2119. Refer to [EC-366, "DTC Logic"](#).

DTC No.	Trouble diagnosis name	DTC detecting condition	Possible cause
P2101	Electric throttle control performance	Electric throttle control function does not operate properly.	<ul style="list-style-type: none">• Harness or connectors (Throttle control motor circuit is open or shorted)• Electric throttle control actuator

DTC CONFIRMATION PROCEDURE

1. PRECONDITIONING

If DTC Confirmation Procedure has been previously conducted, always turn ignition switch OFF and wait at least 10 seconds before conducting the next test.

TESTING CONDITION:

Before performing the following procedure, confirm that battery voltage is more than 11 V when engine is running.

>> GO TO 2.

2. PERFORM DTC CONFIRMATION PROCEDURE

1. Turn ignition switch ON and wait at least 2 seconds.
2. Start engine and let it idle for 5 seconds.
3. Check DTC.

Is DTC detected?

YES >> Go to [EC-360, "Diagnosis Procedure"](#).

NO >> INSPECTION END

Diagnosis Procedure

INFOID:000000004833466

1. CHECK GROUND CONNECTION

1. Turn ignition switch OFF.
2. Check ground connection E38. Refer to [GI-37, "Circuit Inspection"](#).

Is the inspection result normal?

YES >> GO TO 2.

NO >> Repair or replace ground connection.

2. CHECK THROTTLE CONTROL MOTOR RELAY INPUT SIGNAL CIRCUIT-I

1. Check the voltage between ECM harness connector and ground under the following conditions.

P2101 ELECTRIC THROTTLE CONTROL FUNCTION

[MR18DE]

< DTC/CIRCUIT DIAGNOSIS >

ECM		Ground	Condition	Voltage
Connector	Terminal			
F7	2	Ground	Ignition switch: OFF	Approx. 0 V
			Ignition switch: ON	Battery voltage

Is the inspection result normal?

YES >> GO TO 9.

NO >> GO TO 3.

3.CHECK THROTTLE CONTROL MOTOR RELAY POWER SUPPLY CIRCUIT

1. Turn ignition switch OFF.
2. Disconnect ECM harness connector.
3. Disconnect IPDM E/R harness connector.
4. Check the continuity between ECM harness connector and IPDM E/R harness connector.

IPDM E/R		ECM		Continuity
Connector	Terminal	Connector	Terminal	
E15	57	F7	15	Existed

5. Also check harness for short to ground and short to power.

Is the inspection result normal?

YES >> GO TO 5.

NO >> GO TO 4.

4.DETECT MALFUNCTIONING PART

Check the following.

- Harness connectors E8, F8
- Harness for open or short between ECM and IPDM E/R

>> Repair open circuit or short to ground or short to power in harness or connectors.

5.CHECK THROTTLE CONTROL MOTOR RELAY INPUT SIGNAL CIRCUIT-II

1. Check the continuity between ECM harness connector and IPDM E/R harness connector.

IPDM E/R		ECM		Continuity
Connector	Terminal	Connector	Terminal	
E15	54	F7	2	Existed

2. Also check harness for short to ground and short to power.

Is the inspection result normal?

YES >> GO TO 7.

NO >> GO TO 6.

6.DETECT MALFUNCTIONING PART

Check the following.

- Harness connectors E8, F1
- Harness for open or short between ECM and IPDM E/R

>> Repair open circuit or short to ground or short to power in harness or connectors.

7.CHECK FUSE

1. Disconnect 15 A fuse (No. 64) from IPDM E/R.
2. Check 15 A fuse for blown.

Is the inspection result normal?

P2101 ELECTRIC THROTTLE CONTROL FUNCTION

[MR18DE]

< DTC/CIRCUIT DIAGNOSIS >

- YES >> GO TO 8.
NO >> Replace 15 A fuse.

8.CHECK INTERMITTENT INCIDENT

Refer to [GI-34, "Intermittent Incident"](#).

Is the inspection result normal?

- YES >> Replace IPDM E/R.
NO >> Repair or replace harness or connectors.

9.CHECK THROTTLE CONTROL MOTOR OUTPUT SIGNAL CIRCUIT FOR OPEN OR SHORT

1. Turn ignition switch OFF.
2. Disconnect electric throttle control actuator harness connector.
3. Disconnect ECM harness connector.
4. Check the continuity between electric throttle control actuator harness connector and ECM harness connector.

Electric throttle control actuator		ECM		Continuity
Connector	Terminal	Connector	Terminal	
F29	5	F7	1	Not existed
			4	Existed
	6		1	Existed
			4	Not existed

5. Also check harness for short to ground and short to power.

Is the inspection result normal?

- YES >> GO TO 10.
NO >> Repair or replace.

10.CHECK ELECTRIC THROTTLE CONTROL ACTUATOR VISUALLY

1. Remove the intake air duct.
2. Check if foreign matter is caught between the throttle valve (1) and the housing.
 - Electric throttle control actuator (2)

Is the inspection result normal?

- YES >> GO TO 11.
NO >> Remove the foreign matter and clean the electric throttle control actuator inside.

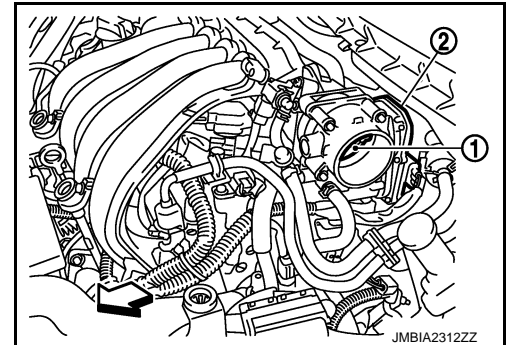

11.CHECK THROTTLE CONTROL MOTOR

Refer to [EC-363, "Component Inspection"](#).

Is the inspection result normal?

- YES >> GO TO 12.
NO >> GO TO 13.

12.CHECK INTERMITTENT INCIDENT

Refer to [GI-34, "Intermittent Incident"](#).

Is the inspection result normal?

- YES >> GO TO 13.
NO >> Repair or replace harness or connectors.

13.REPLACE ELECTRIC THROTTLE CONTROL ACTUATOR

1. Replace malfunction electric throttle control actuator.
2. Perform [EC-363, "Special Repair Requirement"](#).

P2101 ELECTRIC THROTTLE CONTROL FUNCTION

< DTC/CIRCUIT DIAGNOSIS >

[MR18DE]

>> INSPECTION END

A

Component Inspection

INFOID:000000004833467

1. CHECK THROTTLE CONTROL MOTOR

EC

1. Turn ignition switch OFF.
2. Disconnect electric throttle control actuator harness connector.
3. Check the resistance between electric throttle control actuator terminals as per the following.

C

Terminals	Resistance
5 and 6	Approx. 1 - 15 Ω [at 25°C (77°F)]

D

Is the inspection result normal?

E

- YES >> INSPECTION END
NO >> GO TO 2.

2. REPLACE ELECTRIC THROTTLE CONTROL ACTUATOR

F

1. Replace electric throttle control actuator.
2. Perform [EC-363. "Special Repair Requirement"](#).

G

>> INSPECTION END

Special Repair Requirement

INFOID:000000004833468

H

1. PERFORM THROTTLE VALVE CLOSED POSITION LEARNING

Refer to [EC-17. "THROTTLE VALVE CLOSED POSITION LEARNING : Special Repair Requirement"](#)

I

>> GO TO 2.

2. PERFORM IDLE AIR VOLUME LEARNING

J

Refer to [EC-17. "IDLE AIR VOLUME LEARNING : Special Repair Requirement"](#)

>> END

K

L

M

N

O

P

P2118 THROTTLE CONTROL MOTOR

< DTC/CIRCUIT DIAGNOSIS >

[MR18DE]

P2118 THROTTLE CONTROL MOTOR

Description

INFOID:000000004833469

The throttle control motor is operated by the ECM and it opens and closes the throttle valve. The current opening angle of the throttle valve is detected by the throttle position sensor and it provides feedback to the ECM. ECM controls the throttle valve opening angle in response to driving conditions via the throttle control motor.

DTC Logic

INFOID:000000004833470

DTC DETECTION LOGIC

DTC No.	Trouble diagnosis name	DTC detecting condition	Possible cause
P2118	Throttle control motor circuit short	ECM detects short in both circuits between ECM and throttle control motor.	<ul style="list-style-type: none"> Harness or connectors (Throttle control motor circuit is shorted.) Electric throttle control actuator (Throttle control motor)

DTC CONFIRMATION PROCEDURE

1. PRECONDITIONING

If DTC Confirmation Procedure has been previously conducted, always turn ignition switch OFF and wait at least 10 seconds before conducting the next test.

>> GO TO 2.

2. PERFORM DTC CONFIRMATION PROCEDURE

- Turn ignition switch ON and wait at least 2 seconds.
- Start engine and let it idle for 5 seconds.
- Check DTC.

Is DTC detected?

- YES >> Go to [EC-364, "Diagnosis Procedure"](#).
 NO >> INSPECTION END

Diagnosis Procedure

INFOID:000000004833472

1. CHECK GROUND CONNECTION

- Turn ignition switch OFF.
- Check ground connection E38. Refer to [GI-37, "Circuit Inspection"](#).

Is the inspection result normal?

- YES >> GO TO 2.
 NO >> Repair or replace ground connection.

2. CHECK THROTTLE CONTROL MOTOR OUTPUT SIGNAL CIRCUIT FOR OPEN AND SHORT

- Disconnect electric throttle control actuator harness connector.
- Disconnect ECM harness connector.
- Check the continuity between electric throttle control actuator harness connector and ECM harness connector.

Electric throttle control actuator		ECM		Continuity
Connector	Terminal	Connector	Terminal	
F29	5	F7	1	Not existed
			4	Existed
	6		1	Existed
			4	Not existed

P2118 THROTTLE CONTROL MOTOR

[MR18DE]

< DTC/CIRCUIT DIAGNOSIS >

4. Also check harness for short to ground and short to power.

Is the inspection result normal?

YES >> GO TO 3.

NO >> Repair or replace.

3.CHECK THROTTLE CONTROL MOTOR

Refer to [EC-365, "Component Inspection"](#).

Is the inspection result normal?

YES >> GO TO 4.

NO >> GO TO 5.

4.CHECK INTERMITTENT INCIDENT

Refer to [GI-34, "Intermittent Incident"](#).

Is the inspection result normal?

YES >> GO TO 5.

NO >> Repair or replace harness or connectors.

5.REPLACE ELECTRIC THROTTLE CONTROL ACTUATOR

1. Replace electric throttle control actuator.

2. Perform [EC-365, "Special Repair Requirement"](#).

>> INSPECTION END

Component Inspection

INFOID:000000004833473

1.CHECK THROTTLE CONTROL MOTOR

1. Turn ignition switch OFF.

2. Disconnect electric throttle control actuator harness connector.

3. Check the resistance between electric throttle control actuator terminals as per the following.

Terminals	Resistance
5 and 6	Approx. 1 - 15 Ω [at 25°C (77°F)]

Is the inspection result normal?

YES >> INSPECTION END

NO >> GO TO 2.

2.REPLACE ELECTRIC THROTTLE CONTROL ACTUATOR

1. Replace electric throttle control actuator.

2. Perform [EC-365, "Special Repair Requirement"](#).

>> INSPECTION END

Special Repair Requirement

INFOID:000000004833474

1.PERFORM THROTTLE VALVE CLOSED POSITION LEARNING

Refer to [EC-17, "THROTTLE VALVE CLOSED POSITION LEARNING : Special Repair Requirement"](#)

>> GO TO 2.

2.PERFORM IDLE AIR VOLUME LEARNING

Refer to [EC-17, "IDLE AIR VOLUME LEARNING : Special Repair Requirement"](#)

>> END

P2119 ELECTRIC THROTTLE CONTROL ACTUATOR

< DTC/CIRCUIT DIAGNOSIS >

[MR18DE]

P2119 ELECTRIC THROTTLE CONTROL ACTUATOR

Description

INFOID:000000004833475

Electric throttle control actuator consists of throttle control motor, throttle position sensor, etc. The throttle control motor is operated by the ECM and it opens and closes the throttle valve. The throttle position sensor detects the throttle valve position, and feeds the voltage signal to the ECM. The ECM judges the current opening angle of the throttle valve and controls the throttle valve opening angle in response to driving conditions via the throttle control motor.

DTC Logic

INFOID:000000004833476

DTC DETECTION LOGIC

DTC No.	Trouble diagnosis name	DTC detecting condition		Possible cause
P2119	Electric throttle control actuator	A	Electric throttle control actuator does not function properly due to the return spring malfunction.	• Electric throttle control actuator
		B	Throttle valve opening angle in fail-safe mode is not in specified range.	
		C	ECM detect the throttle valve is stuck open.	

DTC CONFIRMATION PROCEDURE

1. PRECONDITIONING

If DTC Confirmation Procedure has been previously conducted, always turn ignition switch OFF and wait at least 10 seconds before conducting the next test.

>> GO TO 2.

2. PERFORM DTC CONFIRMATION PROCEDURE FOR MALFUNCTION A AND B

1. Turn ignition switch ON and wait at least 1 second.
2. Set selector lever to D (CVT) or 1st (M/T) position and wait at least 3 seconds.
3. Set selector lever to P (CVT) or Neutral (M/T) position.
4. Turn ignition switch OFF and wait at least 10 seconds.
5. Turn ignition switch ON and wait at least 1 second.
6. Set selector lever to D (CVT) or 1st (M/T) position and wait at least 3 seconds.
7. Set selector lever to P (CVT) or Neutral (M/T) position.
8. Turn ignition switch OFF, wait at least 10 seconds and then turn ON.
9. Check DTC.

Is DTC detected?

- YES >> Go to [EC-366. "Diagnosis Procedure"](#).
NO >> GO TO 3.

3. PERFORM DTC CONFIRMATION PROCEDURE FOR MALFUNCTION C

1. Turn ignition switch ON and wait at least 1 second.
2. Set selector lever to D (CVT) or 1st (M/T) position and wait at least 3 seconds.
3. Set selector lever to P (CVT) or Neutral (M/T) position.
4. Start engine and let it idle for 3 seconds.
5. Check DTC.

Is DTC detected?

- YES >> Go to [EC-366. "Diagnosis Procedure"](#).
NO >> INSPECTION END

Diagnosis Procedure

INFOID:000000004833477

1. CHECK ELECTRIC THROTTLE CONTROL ACTUATOR VISUALLY

1. Turn ignition switch OFF.
2. Remove the intake air duct.

P2119 ELECTRIC THROTTLE CONTROL ACTUATOR

[MR18DE]

< DTC/CIRCUIT DIAGNOSIS >

3. Check if foreign matter is caught between the throttle valve (1) and the housing.
 - Electric throttle control actuator (2)

Is the inspection result normal?

YES >> GO TO 2.

NO >> Remove the foreign matter and clean the electric throttle control actuator inside.

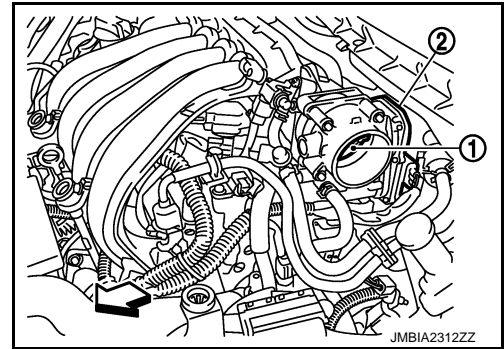

2. REPLACE ELECTRIC THROTTLE CONTROL ACTUATOR

1. Replace electric throttle control actuator.
2. Perform [EC-367, "Special Repair Requirement"](#).

>> INSPECTION END

Special Repair Requirement

INFOID:000000004833478

1. PERFORM THROTTLE VALVE CLOSED POSITION LEARNING

Refer to [EC-17, "THROTTLE VALVE CLOSED POSITION LEARNING : Special Repair Requirement"](#)

>> GO TO 2.

2. PERFORM IDLE AIR VOLUME LEARNING

Refer to [EC-17, "IDLE AIR VOLUME LEARNING : Special Repair Requirement"](#)

>> END

P2122, P2123 APP SENSOR

Description

INFOID:000000004833479

The accelerator pedal position sensor is installed on the upper end of the accelerator pedal assembly. The sensor detects the accelerator position and sends a signal to the ECM.

Accelerator pedal position sensor has two sensors. These sensors are a kind of potentiometer which transform the accelerator pedal position into output voltage, and emit the voltage signal to the ECM. The ECM judges the current opening angle of the accelerator pedal from these signals and controls the throttle control motor based on these signals.

Idle position of the accelerator pedal is determined by the ECM receiving the signal from the accelerator pedal position sensor. The ECM uses this signal for the engine operation such as fuel cut.

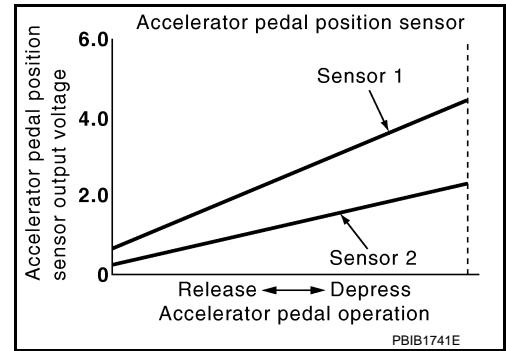

DTC Logic

INFOID:000000004833480

DTC DETECTION LOGIC

NOTE:

If DTC P2122 or P2123 is displayed with DTC P0643, first perform the trouble diagnosis for DTC P0643. Refer to [EC-308, "DTC Logic"](#).

DTC No.	Trouble diagnosis name	DTC detecting condition	Possible cause
P2122	Accelerator pedal position sensor 1 circuit low input	An excessively low voltage from the APP sensor 1 is sent to ECM.	<ul style="list-style-type: none"> Harness or connectors (APP sensor 1 circuit is open or shorted.) Accelerator pedal position sensor (APP sensor 1)
P2123	Accelerator pedal position sensor 1 circuit high input	An excessively high voltage from the APP sensor 1 is sent to ECM.	

DTC CONFIRMATION PROCEDURE

1. PRECONDITIONING

If DTC Confirmation Procedure has been previously conducted, always turn ignition switch OFF and wait at least 10 seconds before conducting the next test.

TESTING CONDITION:

Before performing the following procedure, confirm that battery voltage is more than 8 V at idle.

>> GO TO 2.

2. PERFORM DTC CONFIRMATION PROCEDURE

- Start engine and let it idle for 1 second.
- Check DTC.

Is DTC detected?

- YES >> Go to [EC-368, "Diagnosis Procedure"](#).
- NO >> INSPECTION END

Diagnosis Procedure

INFOID:000000004833482

1. CHECK GROUND CONNECTION

- Turn ignition switch OFF.
- Check ground connection E38. Refer to [GI-37, "Circuit Inspection"](#).

Is the inspection result normal?

- YES >> GO TO 2.
- NO >> Repair or replace ground connection.

2. CHECK APP SENSOR 1 POWER SUPPLY CIRCUIT

- Disconnect accelerator pedal position (APP) sensor harness connector.

P2122, P2123 APP SENSOR

[MR18DE]

< DTC/CIRCUIT DIAGNOSIS >

- Turn ignition switch ON.
- Check the voltage between APP sensor harness connector and ground.

APP sensor		Ground	Voltage
Connector	Terminal		
E110	4	Ground	Approx. 5 V

Is the inspection result normal?

YES >> GO TO 3.

NO >> Repair open circuit or short to ground or short to power in harness or connectors.

3.CHECK APP SENSOR 1 GROUND CIRCUIT FOR OPEN AND SHORT

- Turn ignition switch OFF.
- Disconnect ECM harness connector.
- Check the continuity between APP sensor harness connector and ECM harness connector.

APP sensor		ECM		Continuity
Connector	Terminal	Connector	Terminal	
E110	2	E16	111	Existed

- Also check harness for short to ground and short to power.

Is the inspection result normal?

YES >> GO TO 4.

NO >> Repair open circuit or short to ground or short to power in harness or connectors.

4.CHECK APP SENSOR INPUT SIGNAL CIRCUIT FOR OPEN AND SHORT

- Check the continuity between APP sensor harness connector and ECM harness connector.

APP sensor		ECM		Continuity
Connector	Terminal	Connector	Terminal	
E110	3	E16	110	Existed

- Also check harness for short to ground and short to power.

Is the inspection result normal?

YES >> GO TO 5.

NO >> Repair open circuit or short to ground or short to power in harness or connectors.

5.CHECK APP SENSOR

Refer to [EC-370, "Component Inspection"](#).

Is the inspection result normal?

YES >> GO TO 7.

NO >> GO TO 6.

6.REPLACE ACCELERATOR PEDAL ASSEMBLY

- Replace accelerator pedal assembly.
- Perform [EC-370, "Special Repair Requirement"](#).

>> INSPECTION END

7.CHECK INTERMITTENT INCIDENT

Refer to [GI-34, "Intermittent Incident"](#).

>> INSPECTION END

P2122, P2123 APP SENSOR

< DTC/CIRCUIT DIAGNOSIS >

[MR18DE]

Component Inspection

INFOID:000000004833483

1. CHECK ACCELERATOR PEDAL POSITION SENSOR

1. Reconnect all harness connectors disconnected.
2. Turn ignition switch ON.
3. Check the voltage between ECM harness connector and ground.

ECM		Ground	Condition	Voltage	
Connector	Terminal				
E16	110 (APP sensor 1 signal)	Ground	Accelerator ped- al	Fully released	0.6 - 0.9 V
				Fully depressed	3.9 - 4.7 V
	103 (APP sensor 2 signal)			Fully released	0.3 - 0.6 V
				Fully depressed	1.95 - 2.4 V

Is the inspection result normal?

YES >> INSPECTION END

NO >> GO TO 2.

2. REPLACE ACCELERATOR PEDAL ASSEMBLY

1. Replace accelerator pedal assembly.
2. Perform [EC-370. "Special Repair Requirement"](#).

>> INSPECTION END

Special Repair Requirement

INFOID:000000004833484

1. PERFORM ACCELERATOR PEDAL RELEASED POSITION LEARNING

Refer to [EC-17. "ACCELERATOR PEDAL RELEASED POSITION LEARNING : Special Repair Requirement"](#).

>> GO TO 2.

2. PERFORM THROTTLE VALVE CLOSED POSITION LEARNING

Refer to [EC-17. "THROTTLE VALVE CLOSED POSITION LEARNING : Special Repair Requirement"](#).

>> GO TO 3.

3. PERFORM IDLE AIR VOLUME LEARNING

Refer to [EC-17. "IDLE AIR VOLUME LEARNING : Special Repair Requirement"](#).

>> END

P2127, P2128 APP SENSOR

< DTC/CIRCUIT DIAGNOSIS >

[MR18DE]

P2127, P2128 APP SENSOR

Description

INFOID:000000004833485

The accelerator pedal position sensor is installed on the upper end of the accelerator pedal assembly. The sensor detects the accelerator position and sends a signal to the ECM.

Accelerator pedal position sensor has two sensors. These sensors are a kind of potentiometer which transform the accelerator pedal position into output voltage, and emit the voltage signal to the ECM. The ECM judges the current opening angle of the accelerator pedal from these signals and controls the throttle control motor based on these signals.

Idle position of the accelerator pedal is determined by the ECM receiving the signal from the accelerator pedal position sensor. The ECM uses this signal for the engine operation such as fuel cut.

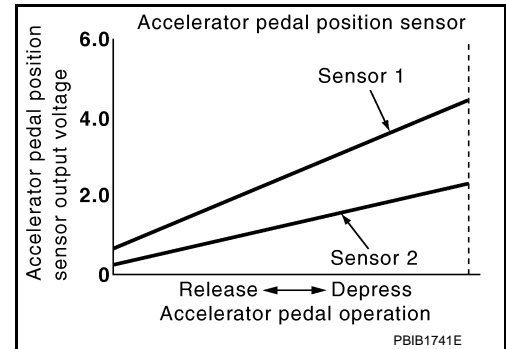

DTC Logic

INFOID:000000004833486

DTC DETECTION LOGIC

DTC No.	Trouble diagnosis name	DTC detecting condition	Possible cause
P2127	Accelerator pedal position sensor 2 circuit low input	An excessively low voltage from the APP sensor 2 is sent to ECM.	<ul style="list-style-type: none"> • Harness or connectors (APP sensor 2 circuit is open or shorted.) [Crankshaft position sensor (POS) circuit is shorted.] (Refrigerant pressure sensor circuit is shorted.) (EVAP control system pressure sensor circuit is shorted.) (Battery current sensor circuit is shorted.) • Accelerator pedal position sensor (APP sensor 2) • Crankshaft position sensor (POS) • Refrigerant pressure sensor • EVAP control system pressure sensor • Battery current sensor
P2128	Accelerator pedal position sensor 2 circuit high input	An excessively high voltage from the APP sensor 2 is sent to ECM.	

DTC CONFIRMATION PROCEDURE

1. PRECONDITIONING

If DTC Confirmation Procedure has been previously conducted, always turn ignition switch OFF and wait at least 10 seconds before conducting the next test.

TESTING CONDITION:

Before performing the following procedure, confirm that battery voltage is more than 8 V at idle.

>> GO TO 2.

2. PERFORM DTC CONFIRMATION PROCEDURE

1. Start engine and let it idle for 1 second.
2. Check DTC.

Is DTC detected?

- YES >> Go to [EC-371. "Diagnosis Procedure"](#).
 NO >> INSPECTION END

Diagnosis Procedure

INFOID:000000004833488

1. CHECK GROUND CONNECTION

1. Turn ignition switch OFF.
2. Check ground connection E38. Refer to [GI-37. "Circuit Inspection"](#).

P2127, P2128 APP SENSOR

[MR18DE]

< DTC/CIRCUIT DIAGNOSIS >

Is the inspection result normal?

- YES >> GO TO 2.
NO >> Repair or replace ground connection.

2.CHECK APP SENSOR 2 POWER SUPPLY CIRCUIT-I

1. Disconnect accelerator pedal position (APP) sensor harness connector.
2. Turn ignition switch ON.
3. Check the voltage between APP sensor harness connector and ground.

APP sensor		Ground	Voltage
Connector	Terminal		
E110	5	Ground	Approx. 5 V

Is the inspection result normal?

- YES >> GO TO 6.
NO >> GO TO 3.

3.CHECK APP SENSOR 2 POWER SUPPLY CIRCUIT-II

1. Turn ignition switch OFF.
2. Disconnect ECM harness connector.
3. Check the continuity between APP sensor harness connector and ECM harness connector.

APP sensor		ECM		Continuity
Connector	Terminal	Connector	Terminal	
E110	5	E16	102	Existed

Is the inspection result normal?

- YES >> GO TO 4.
NO >> Repair open circuit or short to ground or short to power in harness or connectors.

4.CHECK SENSOR POWER SUPPLY CIRCUIT

Check harness for short to power and short to ground, between the following terminals.

ECM		Sensor		
Connector	Terminal	Name	Connector	Terminal
F11	74	Refrigerant pressure sensor	E17	3
	75	CKP sensor (POS)	F15	1
	76	EVAP control system pressure sensor	B104	3
	77	Battery current sensor	F51	1
E16	102	APP sensor	E12	5

Is the inspection result normal?

- YES >> GO TO 5.
NO >> Repair short to ground or short to power in harness or connectors.

5.CHECK COMPONENTS

Check the following.

- Crankshaft position sensor (POS) (Refer to [EC-228, "Component Inspection".](#))
- EVAP control system pressure sensor (Refer to [EC-269, "Component Inspection".](#))
- Refrigerant pressure sensor (Refer to [EC-414, "Diagnosis Procedure".](#))

Is the inspection result normal?

- YES >> GO TO 10.
NO >> Replace malfunctioning component.

6.CHECK APP SENSOR 2 GROUND CIRCUIT FOR OPEN AND SHORT

1. Turn ignition switch OFF.

P2127, P2128 APP SENSOR

[MR18DE]

< DTC/CIRCUIT DIAGNOSIS >

2. Disconnect ECM harness connector.
3. Check the continuity between APP sensor harness connector and ECM harness connector.

APP sensor		ECM		Continuity
Connector	Terminal	Connector	Terminal	
E110	1	E16	104	Existed

4. Also check harness for short to ground and short to power.

Is the inspection result normal?

YES >> GO TO 7.

NO >> Repair open circuit or short to ground or short to power in harness or connectors.

7. CHECK APP SENSOR 2 INPUT SIGNAL CIRCUIT FOR OPEN AND SHORT

1. Check the continuity between APP sensor harness connector and ECM harness connector.

APP sensor		ECM		Continuity
Connector	Terminal	Connector	Terminal	
E110	6	E16	103	Existed

2. Also check harness for short to ground and short to power.

Is the inspection result normal?

YES >> GO TO 8.

NO >> Repair open circuit or short to ground or short to power in harness or connectors.

8. CHECK APP SENSOR

Refer to [EC-373. "Component Inspection"](#).

Is the inspection result normal?

YES >> GO TO 10.

NO >> GO TO 9.

9. REPLACE ACCELERATOR PEDAL ASSEMBLY

1. Replace accelerator pedal assembly.
2. Perform [EC-374. "Special Repair Requirement"](#).

>> INSPECTION END

10. CHECK INTERMITTENT INCIDENT

Refer to [GI-34. "Intermittent Incident"](#).

>> INSPECTION END

Component Inspection

INFOID:000000004833489

1. CHECK ACCELERATOR PEDAL POSITION SENSOR

1. Reconnect all harness connectors disconnected.
2. Turn ignition switch ON.
3. Check the voltage between ECM harness connector and ground.

ECM		Ground	Condition	Voltage
Connector	Terminal			
E16	110 (APP sensor 1 signal)	Ground	Fully released	0.6 - 0.9 V
			Fully depressed	3.9 - 4.7 V
	103 (APP sensor 2 signal)		Fully released	0.3 - 0.6 V
			Fully depressed	1.95 - 2.4 V

P2127, P2128 APP SENSOR

[MR18DE]

< DTC/CIRCUIT DIAGNOSIS >

Is the inspection result normal?

YES >> INSPECTION END

NO >> GO TO 2.

2. REPLACE ACCELERATOR PEDAL ASSEMBLY

1. Replace accelerator pedal assembly.
2. Perform [EC-374, "Special Repair Requirement"](#).

>> INSPECTION END

Special Repair Requirement

INFOID:000000004833490

1. PERFORM ACCELERATOR PEDAL RELEASED POSITION LEARNING

Refer to [EC-17, "ACCELERATOR PEDAL RELEASED POSITION LEARNING : Special Repair Requirement"](#).

>> GO TO 2.

2. PERFORM THROTTLE VALVE CLOSED POSITION LEARNING

Refer to [EC-17, "THROTTLE VALVE CLOSED POSITION LEARNING : Special Repair Requirement"](#).

>> GO TO 3.

3. PERFORM IDLE AIR VOLUME LEARNING

Refer to [EC-17, "IDLE AIR VOLUME LEARNING : Special Repair Requirement"](#).

>> END

P2135 TP SENSOR

< DTC/CIRCUIT DIAGNOSIS >

[MR18DE]

P2135 TP SENSOR

Description

INFOID:000000004833491

Electric throttle control actuator consists of throttle control motor, throttle position sensor, etc. The throttle position sensor responds to the throttle valve movement.

The throttle position sensor has two sensors. These sensors are a kind of potentiometer which transform the throttle valve position into output voltage, and emit the voltage signals to the ECM. The ECM judges the current opening angle of the throttle valve from these signals and controls the throttle valve opening angle in response to driving conditions via the throttle control motor.

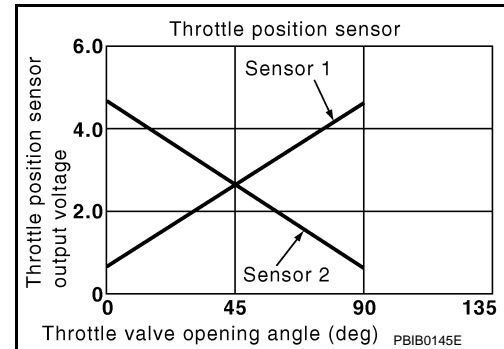

DTC Logic

INFOID:000000004833492

DTC DETECTION LOGIC

NOTE:

If DTC P2135 is displayed with DTC P0643, first perform the trouble diagnosis for DTC P0643. Refer to [EC-308, "DTC Logic"](#).

DTC No.	Trouble diagnosis name	DTC detecting condition	Possible cause
P2135	Throttle position sensor circuit range/performance	Rationally incorrect voltage is sent to ECM compared with the signals from TP sensor 1 and TP sensor 2.	<ul style="list-style-type: none"> Harness or connector (TP sensor 1 or 2 circuit is open or shorted.) Electric throttle control actuator (TP sensor 1 or 2)

DTC CONFIRMATION PROCEDURE

1. PRECONDITIONING

If DTC Confirmation Procedure has been previously conducted, always turn ignition switch OFF and wait at least 10 seconds before conducting the next test.

TESTING CONDITION:

Before performing the following procedure, confirm that battery voltage is more than 8 V at idle.

>> GO TO 2.

2. PERFORM DTC CONFIRMATION PROCEDURE

- Start engine and let it idle for 1 second.
- Check DTC.

Is DTC detected?

- YES >> Go to [EC-375, "Diagnosis Procedure"](#).
 NO >> INSPECTION END

Diagnosis Procedure

INFOID:000000004833494

1. CHECK GROUND CONNECTION

- Turn ignition switch OFF.
- Check ground connection E38. Refer to [GI-37, "Circuit Inspection"](#).

Is the inspection result normal?

- YES >> GO TO 2.
 NO >> Repair or replace ground connection.

2. CHECK THROTTLE POSITION SENSOR POWER SUPPLY CIRCUIT

- Disconnect electric throttle control actuator harness connector.
- Turn ignition switch ON.

P2135 TP SENSOR

[MR18DE]

< DTC/CIRCUIT DIAGNOSIS >

3. Check the voltage between electric throttle control actuator harness connector and ground.

Electric throttle control actuator		Ground	Voltage
Connector	Terminal		
F29	2	Ground	Approx. 5 V

Is the inspection result normal?

YES >> GO TO 3.

NO >> Repair open circuit or short to ground or short to power in harness or connectors.

3.CHECK THROTTLE POSITION SENSOR GROUND CIRCUIT FOR OPEN AND SHORT

1. Turn ignition switch OFF.
2. Disconnect ECM harness connector.
3. Check the continuity between electric throttle control actuator harness connector and ground.

Electric throttle control actuator		ECM		Continuity
Connector	Terminal	Connector	Terminal	
F29	4	F8	36	Existed

4. Also check harness for short to ground and short to power.

Is the inspection result normal?

YES >> GO TO 4.

NO >> Repair open circuit or short to ground or short to power in harness or connectors.

4.CHECK THROTTLE POSITION SENSOR INPUT SIGNAL CIRCUIT FOR OPEN AND SHORT

1. Check the continuity between electric throttle control actuator harness connector and ground.

Electric throttle control actuator		ECM		Continuity
Connector	Terminal	Connector	Terminal	
F29	1	F8	33	Existed
	3		34	

2. Also check harness for short to ground and short to power.

Is the inspection result normal?

YES >> GO TO 5.

NO >> Repair open circuit or short to ground or short to power in harness or connectors.

5.CHECK THROTTLE POSITION SENSOR

Refer to [EC-377, "Component Inspection"](#).

Is the inspection result normal?

YES >> GO TO 7.

NO >> GO TO 6.

6.REPLACE ELECTRIC THROTTLE CONTROL ACTUATOR

1. Replace electric throttle control actuator.
2. Perform [EC-377, "Special Repair Requirement"](#).

>> INSPECTION END

7.CHECK INTERMITTENT INCIDENT

Refer to [GI-34, "Intermittent Incident"](#).

>> INSPECTION END

P2135 TP SENSOR

< DTC/CIRCUIT DIAGNOSIS >

[MR18DE]

Component Inspection

INFOID:000000004833495

1. CHECK THROTTLE POSITION SENSOR

1. Turn ignition switch OFF.
2. Reconnect all harness connectors disconnected.
3. Perform [EC-377. "Special Repair Requirement"](#).
4. Turn ignition switch ON.
5. Set selector lever to D (CVT) or 1st (M/T) position.
6. Check the voltage between ECM harness connector and ground.

ECM		Ground	Condition	Voltage	
Connector	Terminal				
F8	33 (TP sensor 1 signal)	Ground	Accelerator pedal	Fully released	More than 0.36V
				Fully de- pressed	Less than 4.75V
	34 (TP sensor 2 signal)			Fully released	Less than 4.75V
				Fully de- pressed	More than 0.36V

Is the inspection result normal?

- YES >> INSPECTION END
NO >> GO TO 2.

2. REPLACE ELECTRIC THROTTLE CONTROL ACTUATOR

1. Replace electric throttle control actuator.
2. Perform [EC-377. "Special Repair Requirement"](#).

>> INSPECTION END

Special Repair Requirement

INFOID:000000004833496

1. PERFORM THROTTLE VALVE CLOSED POSITION LEARNING

Refer to [EC-17. "THROTTLE VALVE CLOSED POSITION LEARNING : Special Repair Requirement"](#)

>> GO TO 2.

2. PERFORM IDLE AIR VOLUME LEARNING

Refer to [EC-17. "IDLE AIR VOLUME LEARNING : Special Repair Requirement"](#)

>> END

P2138 APP SENSOR

Description

INFOID:000000004833497

The accelerator pedal position sensor is installed on the upper end of the accelerator pedal assembly. The sensor detects the accelerator position and sends a signal to the ECM.

Accelerator pedal position sensor has two sensors. These sensors are a kind of potentiometer which transform the accelerator pedal position into output voltage, and emit the voltage signal to the ECM. The ECM judges the current opening angle of the accelerator pedal from these signals and controls the throttle control motor based on these signals.

Idle position of the accelerator pedal is determined by the ECM receiving the signal from the accelerator pedal position sensor. The ECM uses this signal for the engine operation such as fuel cut.

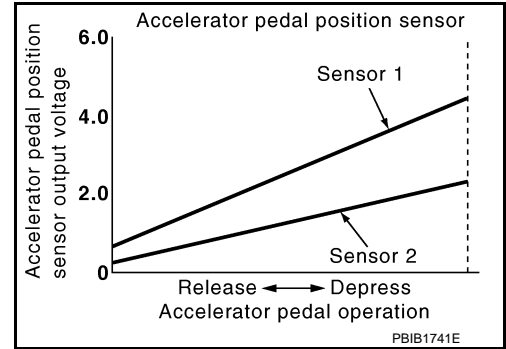

DTC Logic

INFOID:000000004833498

DTC DETECTION LOGIC

NOTE:

If DTC P2138 is displayed with DTC P0643, first perform the trouble diagnosis for DTC P0643. Refer to [EC-308, "DTC Logic"](#).

DTC No.	Trouble diagnosis name	DTC detecting condition	Possible cause
P2138	Accelerator pedal position sensor circuit range/performance	Rationally incorrect voltage is sent to ECM compared with the signals from APP sensor 1 and APP sensor 2.	<ul style="list-style-type: none"> • Harness or connector (APP sensor 1 or 2 circuit is open or shorted.) [Crankshaft position sensor (POS) circuit is shorted.] (Refrigerant pressure sensor circuit is shorted.) (EVAP control system sensor circuit is shorted.) (Battery current sensor circuit is shorted.) • Accelerator pedal position sensor (APP sensor 1 or 2) • Crankshaft position sensor (POS) • Refrigerant pressure sensor • EVAP control system pressure sensor • Battery current sensor

DTC CONFIRMATION PROCEDURE

1. PRECONDITIONING

If DTC Confirmation Procedure has been previously conducted, always turn ignition switch OFF and wait at least 10 seconds before conducting the next test.

TESTING CONDITION:

Before performing the following procedure, confirm that battery voltage is more than 8 V at idle.

>> GO TO 2.

2. PERFORM DTC CONFIRMATION PROCEDURE

1. Start engine and let it idle for 1 second.
2. Check DTC.

Is DTC detected?

- YES >> Go to [EC-379, "Diagnosis Procedure"](#).
- NO >> INSPECTION END

P2138 APP SENSOR

[MR18DE]

< DTC/CIRCUIT DIAGNOSIS >

INFOID:000000004833500

Diagnosis Procedure

1. CHECK GROUND CONNECTION

1. Turn ignition switch OFF.
2. Check ground connection E38. Refer to [GI-37. "Circuit Inspection"](#).

Is the inspection result normal?

- YES >> GO TO 2.
NO >> Repair or replace ground connection.

2. CHECK APP SENSOR 1 POWER SUPPLY CIRCUIT

1. Disconnect accelerator pedal position (APP) sensor harness connector.
2. Turn ignition switch ON.
3. Check the voltage between APP sensor harness connector and ground.

APP sensor		Ground	Voltage
Connector	Terminal		
E110	4	Ground	Approx. 5 V

Is the inspection result normal?

- YES >> GO TO 3.
NO >> Repair open circuit or short to ground or shot to power in harness or connectors.

3. CHECK APP SENSOR 2 POWER SUPPLY CIRCUIT-I

1. Check the voltage between APP sensor harness connector and ground.

APP sensor		Ground	Voltage
Connector	Terminal		
E110	5	Ground	Approx. 5 V

Is the inspection result normal?

- YES >> GO TO 7.
NO >> GO TO 4.

4. CHECK APP SENSOR 2 POWER SUPPLY CIRCUIT-II

1. Turn ignition switch OFF.
2. Disconnect ECM harness connector.
3. Check the continuity between APP sensor harness connector and ECM harness connector.

APP sensor		ECM		Continuity
Connector	Terminal	Connector	Terminal	
E110	4	E16	106	Existed

Is the inspection result normal?

- YES >> GO TO 5.
NO >> Repair open circuit or short to ground or shot to power in harness or connectors.

5. CHECK SENSOR POWER SUPPLY CIRCUIT

Check harness for short to power and short to ground, between the following terminals.

P2138 APP SENSOR

[MR18DE]

< DTC/CIRCUIT DIAGNOSIS >

ECM		Sensor		
Connector	Terminal	Name	Connector	Terminal
F8	74	Refrigerant pressure sensor	E17	3
	75	CKP sensor (POS)	F15	1
	76	EVAP control system pressure sensor	B104	3
	77	Battery current sensor	F51	1
E16	102	APP sensor	E12	5

Is the inspection result normal?

YES >> GO TO 6.

NO >> Repair short to ground or short to power in harness or connectors.

6.CHECK COMPONENTS

Check the following.

- Crankshaft position sensor (POS) (Refer to [EC-228, "Component Inspection".](#))
- EVAP control system pressure sensor (Refer to [EC-269, "Component Inspection".](#))
- Refrigerant pressure sensor (Refer to [EC-414, "Diagnosis Procedure".](#))

Is the inspection result normal?

YES >> GO TO 11.

NO >> Replace malfunctioning component.

7.CHECK APP SENSOR GROUND CIRCUIT FOR OPEN AND SHORT

1. Turn ignition switch OFF.
2. Disconnect ECM harness connector.
3. Check the continuity between APP sensor harness connector and ECM harness connector as per the following.

APP sensor		ECM		Continuity
Connector	Terminal	Connector	Terminal	
E110	2	E16	111	Existed
	1		104	

4. Also check harness for short to ground and short to power.

Is the inspection result normal?

YES >> GO TO 8.

NO >> Repair open circuit or short to ground or short to power in harness or connectors.

8.CHECK APP SENSOR INPUT SIGNAL CIRCUIT FOR OPEN AND SHORT

1. Check the continuity between APP sensor harness connector and ECM harness connector as per the following.

APP sensor		ECM		Continuity
Connector	Terminal	Connector	Terminal	
E110	3	E16	110	Existed
	6		103	

2. Also check harness for short to ground and short to power.

Is the inspection result normal?

YES >> GO TO 9.

NO >> Repair open circuit or short to ground or short to power in harness or connectors.

9.CHECK APP SENSOR

Refer to [EC-381, "Component Inspection".](#)

Is the inspection result normal?

P2138 APP SENSOR

[MR18DE]

< DTC/CIRCUIT DIAGNOSIS >

- YES >> GO TO 11.
- NO >> GO TO 10.

10. REPLACE ACCELERATOR PEDAL ASSEMBLY

1. Replace accelerator pedal assembly.
2. Perform [EC-381, "Special Repair Requirement"](#).

>> INSPECTION END

11. CHECK INTERMITTENT INCIDENT

Refer to [GI-34, "Intermittent Incident"](#).

>> INSPECTION END

Component Inspection

INFOID:000000004833501

1. CHECK ACCELERATOR PEDAL POSITION SENSOR

1. Reconnect all harness connectors disconnected.
2. Turn ignition switch ON.
3. Check the voltage between ECM harness connector and ground.

ECM		Ground	Condition	Voltage
Connector	Terminal			
E16	110 (APP sensor 1 signal)	Ground	Fully released	0.6 - 0.9 V
	103 (APP sensor 2 signal)		Fully depressed	3.9 - 4.7 V
			Fully released	0.3 - 0.6 V
			Fully depressed	1.95 - 2.4 V

Is the inspection result normal?

- YES >> INSPECTION END
- NO >> GO TO 2.

2. REPLACE ACCELERATOR PEDAL ASSEMBLY

1. Replace accelerator pedal assembly.
2. Perform [EC-381, "Special Repair Requirement"](#).

>> INSPECTION END

Special Repair Requirement

INFOID:000000004833502

1. PERFORM ACCELERATOR PEDAL RELEASED POSITION LEARNING

Refer to [EC-17, "ACCELERATOR PEDAL RELEASED POSITION LEARNING : Special Repair Requirement"](#).

>> GO TO 2.

2. PERFORM THROTTLE VALVE CLOSED POSITION LEARNING

Refer to [EC-17, "THROTTLE VALVE CLOSED POSITION LEARNING : Special Repair Requirement"](#).

>> GO TO 3.

3. PERFORM IDLE AIR VOLUME LEARNING

Refer to [EC-17, "IDLE AIR VOLUME LEARNING : Special Repair Requirement"](#).

>> END

P2A00 A/F SENSOR 1

Description

INFOID:000000004833503

The air fuel ratio (A/F) sensor 1 is a planar one-cell limit current sensor. The sensor element of the A/F sensor 1 is composed an electrode layer, which transports ions. It has a heater in the element. The sensor is capable of precise measurement $\lambda = 1$, but also in the lean and rich range. Together with its control electronics, the sensor outputs a clear, continuous signal throughout a wide λ range. The exhaust gas components diffuse through the diffusion layer at the sensor cell. An electrode layer is applied voltage, and this current relative oxygen density in lean. Also this current relative hydrocarbon density in rich.

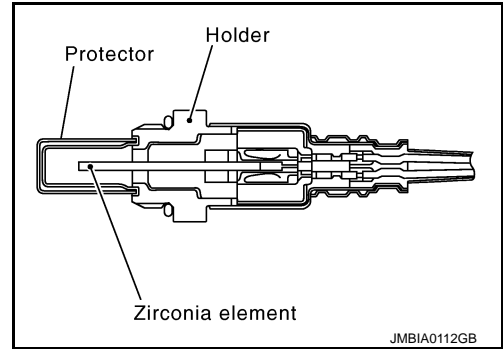

Therefore, the A/F sensor 1 is able to indicate air fuel ratio by this electrode layer of current. In addition, a heater is integrated in the sensor to ensure the required operating temperature of about 800°C (1,472°F).

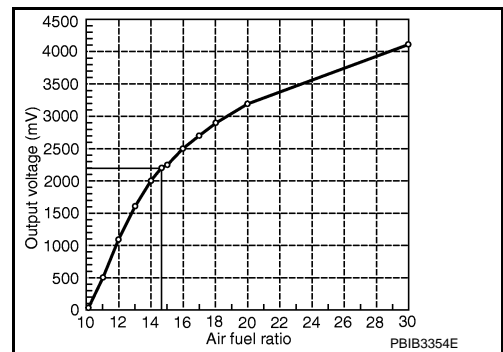

DTC Logic

INFOID:000000004833504

DTC DETECTION LOGIC

To judge the malfunction, the A/F signal computed by ECM from the A/F sensor 1 signal is monitored not to be shifted to LEAN side or RICH side.

DTC No.	Trouble diagnosis name	DTC detecting condition	Possible Cause
P2A00	Air fuel ratio (A/F) sensor 1 circuit range/performance	<ul style="list-style-type: none"> The output voltage computed by ECM from the A/F sensor 1 signal is shifted to the lean side for a specified period. The A/F signal computed by ECM from the A/F sensor 1 signal is shifted to the rich side for a specified period. 	<ul style="list-style-type: none"> A/F sensor 1 A/F sensor 1 heater Fuel pressure Fuel injector Intake air leaks

DTC CONFIRMATION PROCEDURE

1. PRECONDITIONING

If DTC Confirmation Procedure has been previously conducted, always turn ignition switch OFF and wait at least 10 seconds before conducting the next test.

TESTING CONDITION:

Before performing the following procedure, confirm that battery voltage is more than 11 V at idle.

>> GO TO 2.

2. PERFORM DTC CONFIRMATION PROCEDURE

1. Clear the mixture ratio self-learning value. Refer to [EC-19, "MIXTURE RATIO SELF-LEARNING VALUE CLEAR : Special Repair Requirement"](#).
2. Turn ignition switch OFF and wait at least 10 seconds.
3. Start engine and keep the engine speed between 3,500 and 4,000 rpm for 1 minute under no load.
4. Let engine idle for 1 minute.
5. Keep engine speed between 2,500 and 3,000 rpm for 20 minutes.

< DTC/CIRCUIT DIAGNOSIS >

6. Check 1st trip DTC.

Is 1st trip DTC detected?

- YES >> Go to [EC-383, "Diagnosis Procedure"](#).
- NO >> INSPECTION END

Diagnosis Procedure

INFOID:000000004833506

EC

1.CHECK GROUND CONNECTION

1. Turn ignition switch OFF.
2. Check ground connection E38. Refer to [GI-37, "Circuit Inspection"](#).

Is the inspection result normal?

- YES >> GO TO 2.
- NO >> Repair or replace ground connection.

2.CHECK HARNESS CONNECTOR

1. Disconnect A/F sensor 1 harness connector.
2. Check harness connector for water.

Water should not exit.

Is the inspection result normal?

- YES >> GO TO 3.
- NO >> Repair or replace harness connector.

3.RETIGHTEN A/F SENSOR 1

1. Loosen and retighten the A/F sensor 1. Refer to [EM-29, "Exploded View"](#).

>> GO TO 4.

4.CHECK FOR INTAKE AIR LEAK

1. Reconnect A/F sensor 1 harness connector.
2. Start engine and run it at idle.
3. Listen for an intake air leak after the mass air flow sensor.

Is intake air leak detected?

- YES >> GO TO 5.
- NO >> Repair or replace.

5.CLEAR THE MIXTURE RATIO SELF-LEARNING VALUE

1. Clear the mixture ratio self-learning value. Refer to [EC-19, "MIXTURE RATIO SELF-LEARNING VALUE CLEAR : Special Repair Requirement"](#).
2. Run engine for at least 10 minutes at idle speed.

Is the 1st trip DTC P0171 or P0172 detected? Is it difficult to start engine?

- YES >> Perform trouble diagnosis for DTC P0171 or P0172. Refer to [EC-200, "DTC Logic"](#) or [EC-204, "DTC Logic"](#).
- NO >> GO TO 6.

6.CHECK A/F SENSOR 1 POWER SUPPLY CIRCUIT

1. Disconnect A/F sensor 1 harness connector.
2. Turn ignition switch ON.
3. Check the voltage between A/F sensor 1 harness connector and ground.

A/F sensor 1		Ground	Voltage
Connector	Terminal		
F50	4	Ground	Battery voltage

Is the inspection result normal?

- YES >> GO TO 8.
- NO >> GO TO 7.

< DTC/CIRCUIT DIAGNOSIS >

7. DETECT MALFUNCTIONING PART

Check the following.

- Harness connectors E8, F1
- IPDM E/R harness connector E45
- 10 A fuse (No. 54)
- Harness for open or short between A/F sensor 1 and fuse

>> Repair or replace harness or connectors.

8. CHECK A/F SENSOR 1 INPUT SIGNAL CIRCUIT FOR OPEN AND SHORT

1. Turn ignition switch OFF.
2. Disconnect ECM harness connector.
3. Check the continuity between A/F sensor 1 harness connector and ECM harness connector.

A/F sensor 1		ECM		Continuity
Connector	Terminal	Connector	Terminal	
F50	1	F8	49	Existed
	2		53	

4. Check the continuity between A/F sensor 1 harness connector and ground, or ECM harness connector and ground.

A/F sensor 1		Ground	Continuity
Connector	Terminal		
F50	1	Ground	Not existed
	2		

ECM		Ground	Continuity
Connector	Terminal		
F8	49	Ground	Not existed
	53		

5. Also check harness for short to power.

Is the inspection result normal?

YES >> GO TO 9.

NO >> Repair open circuit or short to ground or short to power in harness or connectors.

9. CHECK A/F SENSOR 1 HEATER

Refer to [EC-129, "Component Inspection"](#).

Is the inspection result normal?

YES >> GO TO 10.

NO >> GO TO 11.

10. CHECK INTERMITTENT INCIDENT

Perform [GI-34, "Intermittent Incident"](#).

Is the inspection result normal?

YES >> GO TO 11.

NO >> Repair or replace.

11. REPLACE AIR FUEL RATIO (A/F) SENSOR 1

Replace air fuel ratio (A/F) sensor 1.

CAUTION:

- Discard any sensor which has been dropped from a height of more than 0.5 m (19.7 in) onto a hard surface such as a concrete floor; use a new one.

P2A00 A/F SENSOR 1

[MR18DE]

< DTC/CIRCUIT DIAGNOSIS >

- Before installing new sensor, clean exhaust system threads using Oxygen Sensor Thread Cleaner [commercial service tool (J-43897-18 or J-43897-12)] and approved Anti-seize Lubricant (commercial service tool).

Do you have CONSULT-III?

YES >> GO TO 12.

NO >> GO TO 13.

12.CONFIRM A/F ADJUSTMENT DATA

Ⓜ With CONSULT-III

1. Turn ignition switch ON.
2. Select "A/F ADJ-B1" in "DATA MONITOR" mode with CONSULT-III.
3. Make sure that "0.000" is displayed on CONSULT-III screen.

Is "0.000" displayed?

YES >> INSPECTION END

NO >> GO TO 13.

13.CLEAR THE MIXTURE RATIO SELF-LEARNING VALUE

Clear the mixture ratio self-learning value. Refer to [EC-19, "MIXTURE RATIO SELF-LEARNING VALUE CLEAR : Special Repair Requirement"](#).

Do you have CONSULT-III?

YES >> GO TO 14.

NO >> INSPECTION END

14.CONFIRM A/F ADJUSTMENT DATA

Ⓜ With CONSULT-III

1. Turn ignition switch ON.
2. Select "A/F ADJ-B1" in "DATA MONITOR" mode with CONSULT-III.
3. Make sure that "0.000" is displayed on CONSULT-III screen.

>> INSPECTION END

A
EC
C
D
E
F
G
H
I
J
K
L
M
N
O
P

ASCD BRAKE SWITCH

< DTC/CIRCUIT DIAGNOSIS >

[MR18DE]

ASCD BRAKE SWITCH

Description

INFOID:000000005040382

When the brake pedal is depressed, ASCD brake switch is turned OFF and stop lamp switch is turned ON. ECM detects the state of the brake pedal by this input of two kinds (ON/OFF signal). Refer to [EC-51, "System Description"](#) for the ASCD function.

Component Function Check

INFOID:000000005040383

1. CHECK FOR ASCD BRAKE SWITCH FUNCTION

With CONSULT-III

1. Turn ignition switch ON.
2. Select "BRAKE SW1" in "DATA MONITOR" mode with CONSULT-III.
3. Check "BRAKE SW1" indication under the following conditions.

Monitor item	Condition	Indication
BRAKE SW1	Brake pedal (CVT)	Slightly depressed
	Brake pedal and clutch pedal (M/T)	Fully released
		OFF
		ON

Without CONSULT-III

1. Turn ignition switch ON.
2. Check the voltage between ECM harness connector terminals.

Connector	ECM		Condition	Voltage
	+	-		
	Terminal	Terminal		
E16	100 (ASCD brake switch signal)	108	Brake pedal (CVT)	Slightly depressed
			Brake pedal and clutch pedal (M/T)	Fully released
				Approx. 0 V
				Battery voltage

Is the inspection result normal?

- YES >> INSPECTION END
NO >> Go to [EC-386, "Diagnosis Procedure"](#).

Diagnosis Procedure

INFOID:000000005040384

1. CHECK ASCD BRAKE SWITCH POWER SUPPLY CIRCUIT-I

1. Turn ignition switch OFF.
2. Disconnect ASCD brake switch harness connector.
3. Turn ignition switch ON.
4. Check the voltage between ASCD brake switch harness connector and ground.

ASCD brake switch		Ground	Voltage
Connector	Terminal		
E112	1	Ground	Battery voltage

Is the inspection result normal?

- YES >> GO TO 7.
NO-1 >> CVT models: GO TO 2.
NO-2 >> M/T models: GO TO 3.

2. DETECT MALFUNCTIONING PART

Check the following.

- Harness connectors E105, M77

ASCD BRAKE SWITCH

[MR18DE]

< DTC/CIRCUIT DIAGNOSIS >

- 10 A fuse (No. 2)
- Harness for open or short between ASCD brake switch and fuse

>> Repair open circuit or short to ground or short to power in harness or connectors.

3. CHECK ASCD CLUTCH SWITCH POWER SUPPLY CIRCUIT

1. Turn ignition switch OFF.
2. Disconnect ASCD clutch switch harness connector.
3. Turn ignition switch ON.
4. Check the voltage between ASCD clutch switch harness connector and ground.

ASCD clutch switch		Ground	Voltage
Connector	Terminal		
E111	3	Ground	Battery voltage

Is the inspection result normal?

YES >> GO TO 5.

NO >> GO TO 4.

4. DETECT MALFUNCTIONING PART

Check the following.

- Harness connectors E105, M77
- 10 A fuse (No. 2)
- Harness for open or short between ASCD clutch switch and fuse

>> Repair open circuit or short to ground or short to power in harness or connectors.

5. CHECK ASCD BRAKE SWITCH POWER SUPPLY CIRCUIT-II

1. Turn ignition switch OFF.
2. Disconnect ASCD brake switch harness connector.
3. Check the continuity between ASCD clutch switch harness connector and ASCD brake switch harness connector.

ASCD clutch switch		ASCD brake switch		Continuity
Connector	Terminal	Connector	Terminal	
E111	4	E112	1	Existed

4. Also check harness for short to ground and short to power.

Is the inspection result normal?

YES >> GO TO 6.

NO >> Repair open circuit or short to ground or short to power in harness or connectors.

6. CHECK ASCD CLUTCH SWITCH

Refer to [EC-388. "Component Inspection \(ASCD Clutch Switch\)".](#)

Is the inspection result normal?

YES >> GO TO 9.

NO >> Replace ASCD clutch switch.

7. CHECK ASCD BRAKE SWITCH INPUT SIGNAL CIRCUIT FOR OPEN AND SHORT

1. Turn ignition switch OFF.
2. Disconnect ECM harness connector.
3. Check the continuity between ASCD brake switch harness connector and ECM harness connector.

ASCD brake switch		ECM		Continuity
Connector	Terminal	Connector	Terminal	
E112	2	E16	100	Existed

ASCD BRAKE SWITCH

[MR18DE]

< DTC/CIRCUIT DIAGNOSIS >

4. Also check harness for short to ground and short to power.

Is the inspection result normal?

YES >> GO TO 8.

NO >> Repair open circuit or short to ground or short to power in harness or connectors.

8.CHECK ASCD BRAKE SWITCH

Refer to [EC-388, "Component Inspection \(ASCD Brake Switch\)"](#).

Is the inspection result normal?

YES >> GO TO 9.

NO >> Replace ASCD brake switch.

9.CHECK INTERMITTENT INCIDENT

Refer to [GI-34, "Intermittent Incident"](#).

>> INSPECTION END

Component Inspection (ASCD Brake Switch)

INFOID:000000005040385

1.CHECK ASCD BRAKE SWITCH-I

1. Turn ignition switch OFF.
2. Disconnect ASCD brake switch harness connector.
3. Check the continuity between ASCD brake switch terminals under the following conditions.

Terminals	Condition		Continuity
1 and 2	Brake pedal	Fully released	Existed
		Slightly depressed	Not existed

Is the inspection result normal?

YES >> INSPECTION END

NO >> GO TO 2.

2.CHECK ASCD BRAKE SWITCH-II

1. Adjust ASCD brake switch installation. Refer to [BR-7, "Inspection and Adjustment"](#).
2. Check the continuity between ASCD brake switch terminals under the following conditions.

Terminals	Condition		Continuity
1 and 2	Brake pedal	Fully released	Existed
		Slightly depressed	Not existed

Is the inspection result normal?

YES >> INSPECTION END

NO >> Replace ASCD brake switch.

Component Inspection (ASCD Clutch Switch)

INFOID:000000005040386

1.CHECK ASCD CLUTCH SWITCH-I

1. Turn ignition switch OFF.
2. Disconnect ASCD clutch switch harness connector.
3. Check the continuity between ASCD clutch switch terminals under the following conditions.

Terminals	Condition		Continuity
1 and 2	Clutch pedal	Fully released	Existed
		Slightly depressed	Not existed

ASCD BRAKE SWITCH

[MR18DE]

< DTC/CIRCUIT DIAGNOSIS >

Is the inspection result normal?

YES >> INSPECTION END

NO >> GO TO 2.

2. CHECK ASCD CLUTCH SWITCH-II

1. Adjust ASCD clutch switch installation. Refer to [BR-7. "Inspection and Adjustment"](#).
2. Check the continuity between ASCD clutch switch terminals under the following conditions.

Terminals	Condition		Continuity
1 and 2	Clutch pedal	Fully released	Existed
		Slightly depressed	Not existed

Is the inspection result normal?

YES >> INSPECTION END

NO >> Replace ASCD clutch switch.

A

EC

C

D

E

F

G

H

I

J

K

L

M

N

O

P

ASC D INDICATOR

Description

INFOID:000000005040387

ASC D indicator lamp illuminates to indicate ASC D operation status. Lamp has two indicators, CRUISE and SET, and is integrated in combination meter.

CRUISE lamp illuminates when MAIN switch on ASC D steering switch is turned ON to indicated that ASC D system is ready for operation.

SET lamp illuminates when following conditions are met.

- CRUISE lamp is illuminated.
- SET/COAST switch on ASC D steering switch is turned ON while vehicle speed is within the range of ASC D setting.

SET lamp remains lit during ASC D control.

Refer to [EC-51, "System Description"](#) for the ASC D function.

Component Function Check

INFOID:000000005040388

1. ASC D INDICATOR FUNCTION

Check ASC D indicator under the following conditions.

ASC D INDICATOR	CONDITION		SPECIFICATION
CRUISE LAMP	<ul style="list-style-type: none"> • Ignition switch: ON 	<ul style="list-style-type: none"> • MAIN switch: Pressed at the 1st time → at the 2nd time 	ON → OFF
SET LAMP	<ul style="list-style-type: none"> • MAIN switch: ON • When vehicle speed: Between 40 km/h (25 MPH) and 190 km/h (118 MPH) (For the Middle East), 40 km/h (25 MPH) and 160 km/h (100 MPH) (Except for the Middle East) 	<ul style="list-style-type: none"> • ASC D: Operating 	ON
		<ul style="list-style-type: none"> • ASC D: Not operating 	OFF

Is the inspection result normal?

YES >> INSPECTION END

NO >> Go to [EC-390, "Diagnosis Procedure"](#).

Diagnosis Procedure

INFOID:000000005040389

1. CHECK DTC

Check that DTC U1001 is not displayed.

Is DTC detected?

NO >> GO TO 2.

YES >> Perform trouble diagnosis for DTC U1001. Refer to [EC-122, "DTC Logic"](#).

2. CHECK COMBINATION METER OPERATION

Refer to [MWI-6, "METER SYSTEM : System Description"](#).

Is the inspection result normal?

YES >> GO TO 3.

NO >> Check combination meter circuit. Refer to [MWI-6, "METER SYSTEM : System Diagram"](#).

3. CHECK INTERMITTENT INCIDENT

Refer to [GI-34, "Intermittent Incident"](#).

>> INSPECTION END

COOLING FAN

Description

INFOID:000000004833507

The ECM controls the cooling fan corresponding to the vehicle speed, engine coolant temperature, refrigerant pressure, and air conditioner ON signal. The control system has 3-step control [HIGH/LOW/OFF].

COOLING FAN MOTOR

Models without A/C

The cooling fan operates at each speed when the current flows in the cooling fan motor as prt the following.

Cooling fan Speed	Cooling fan motor terminals	
	(+)	(-)
Low (LOW)	1	3 and 4
	2	3 and 4
	1 and 2	3
	1 and 2	4
High (HI)	1 and 2	3 and 4

Models with A/C

The cooling fan operates at high (HI) speed when the current flows, and operates at low (LOW) speed when cooling fan motor and the resistor are circuited in series.

Component Function Check

INFOID:000000004833508

1. CHECK COOLING FAN FUNCTION

With CONSULT-III

1. Turn ignition switch ON.
2. Perform "COOLING FAN" in "ACTIVE TEST" mode with CONSULT-III.
3. Touch "LOW" and "HI" on the CONSULT-III screen.
4. Check that cooling fan operates at each speed.

Without CONSULT-III

1. Perform IPDM E/R auto active test and check cooling fan motor operation. Refer to [PCS-11, "Diagnosis Description"](#) or [PCS-42, "Diagnosis Description"](#).
2. Check that cooling fan operates at each speed.

Is the inspection result normal?

- YES >> INSPECTION END
- NO >> Refer to [EC-391, "Diagnosis Procedure"](#).

Diagnosis Procedure

INFOID:000000004833510

1. CHECK GROUND CONNECTION

1. Turn ignition switch OFF.
2. Check ground connection E21. Refer to Ground Inspection in [GI-37, "Circuit Inspection"](#).

Is the inspection result normal?

- YES >> GO TO 2.
- NO >> Repair or replace ground connection.

2. CHECK COOLING FAN MOTOR CIRCUIT

1. Disconnect cooling fan motor harness connector.
2. Check the continuity between IPDM E/R harness connector and cooling fan motor harness connector.

COOLING FAN

[MR18DE]

< DTC/CIRCUIT DIAGNOSIS >

IPDM E/R		Cooling fan motor		Continuity
Connector	Terminal	Connector	Terminal	
E10	5	E62	1	Existed
	7		2	
E11	10		3	

3. Check the continuity between cooling fan motor harness connector and ground.

Cooling fan motor		Ground	Continuity
Connector	Terminal		
E62	4	Ground	Existed

4. Also check harness for short to ground and short to power.

OK or NG

- OK >> GO TO 4.
- NG >> GO TO 3.

3. DETECT MALFUNCTIONING PART

Check the following.

- Harness for open or short between cooling fan motor and IPDM E/R
- Harness for open or short between cooling fan motor and ground

>> Repair open circuit or short to ground or short to power in harness or connectors.

4. CHECK COOLING FAN MOTOR

Refer to [EC-392, "Component Inspection"](#).

OK or NG

- OK >> GO TO 5.
- NG >> Replace cooling fan motor.

5. CHECK INTERMITTENT INCIDENT

Perform [GI-34, "Intermittent Incident"](#).

OK or NG

- OK >> Replace IPDM E/R. Refer to [PCS-35, "Removal and Installation"](#)(WITH I-Key) or [PCS-65, "Removal and Installation"](#)(WITHOUT I-Key).
- NG >> Repair or replace harness or connector.

Component Inspection

INFOID:000000004833511

COOLING FAN MOTOR

1. Disconnect cooling fan motor harness connectors.
2. Supply cooling fan motor terminals with battery voltage and check operation.

	Speed	terminals	
		(+)	(-)
Cooling fan motor	Low	1	4
		2	3
	High	1 and 2	3 and 4

Cooling fan motor should operate.

If NG, replace cooling fan motor.

ELECTRICAL LOAD SIGNAL

[MR18DE]

< DTC/CIRCUIT DIAGNOSIS >

ELECTRICAL LOAD SIGNAL

Description

INFOID:000000004833512

The electrical load signal (Headlamp switch signal, rear window defogger switch signal, etc.) is transferred via the CAN communication line.

Component Function Check

INFOID:000000004833513

1. CHECK REAR WINDOW DEFOGGER SWITCH FUNCTION

1. Turn ignition switch ON.
2. Connect CONSULT-III and select "DATA MONITOR" mode.
3. Select "LOAD SIGNAL" and check indication under the following conditions.

Monitor item	Condition		Indication
LOAD SIGNAL	Rear window defogger switch	ON	ON
		OFF	OFF

Is the inspection result normal?

- YES >> GO TO 2.
NO >> Go to [EC-393, "Diagnosis Procedure"](#).

2. CHECK LIGHTING SWITCH FUNCTION

Check "LOAD SIGNAL" indication under the following conditions.

Monitor item	Condition		Indication
LOAD SIGNAL	Lighting switch	ON at 2nd position	ON
		OFF	OFF

Is the inspection result normal?

- YES >> GO TO 3.
NO >> Go to [EC-393, "Diagnosis Procedure"](#).

3. CHECK HEATER FAN CONTROL SWITCH FUNCTION

Select "HEATER FAN SW" and check indication under the following conditions.

Monitor item	Condition		Indication
HEATER FAN SW	Heater fan control switch	ON	ON
		OFF	OFF

Is the inspection result normal?

- YES >> INSPECTION END
NO >> Go to [EC-393, "Diagnosis Procedure"](#).

Diagnosis Procedure

INFOID:000000004833514

1. INSPECTION START

Confirm the malfunctioning circuit (rear window defogger, headlamp or heater fan). Refer to [EC-393, "Component Function Check"](#).

Which circuit is related to the incident?

- Rear window defogger>>GO TO 2.
Headlamp>>GO TO 3.
Heater fan>>GO TO 4.

2. CHECK REAR WINDOW DEFOGGER SYSTEM

Refer to [DEF-4, "Work Flow"](#).

ELECTRICAL LOAD SIGNAL

< DTC/CIRCUIT DIAGNOSIS >

[MR18DE]

>> INSPECTION END

3.CHECK HEADLAMP SYSTEM

Refer to [EXL-5. "Work Flow"](#).

>> INSPECTION END

4.CHECK HEATER FAN CONTROL SYSTEM

Refer to [HA-3. "Work Flow"](#).

>> INSPECTION END

FUEL INJECTOR

Description

INFOID:000000004833515

The fuel injector is a small, precise solenoid valve. When the ECM supplies a ground to the fuel injector circuit, the coil in the fuel injector is energized. The energized coil pulls the ball valve back and allows fuel to flow through the fuel injector into the intake manifold. The amount of fuel injected depends upon the injection pulse duration. Pulse duration is the length of time the fuel injector remains open. The ECM controls the injection pulse duration based on engine fuel needs.

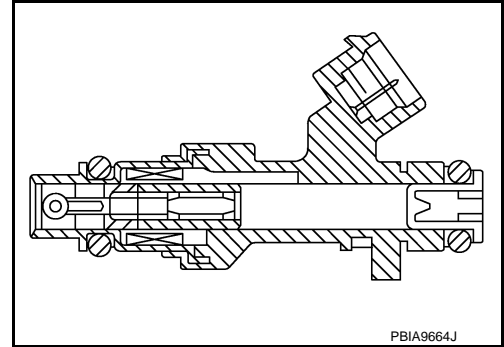

Component Function Check

INFOID:000000004833516

1. INSPECTION START

Turn ignition switch to START.

Is any cylinder ignited?

YES >> GO TO 2.

NO >> Go to [EC-395, "Diagnosis Procedure"](#).

2. CHECK FUEL INJECTOR FUNCTION

With CONSULT-III

1. Start engine.
2. Perform "POWER BALANCE" in "ACTIVE TEST" mode with CONSULT-III.
3. Make sure that each circuit produces a momentary engine speed drop.

Without CONSULT-III

1. Let engine idle.
2. Listen to each fuel injector operating sound.

Clicking noise should be heard.

Is the inspection result normal?

YES >> INSPECTION END

NO >> Go to [EC-395, "Diagnosis Procedure"](#).

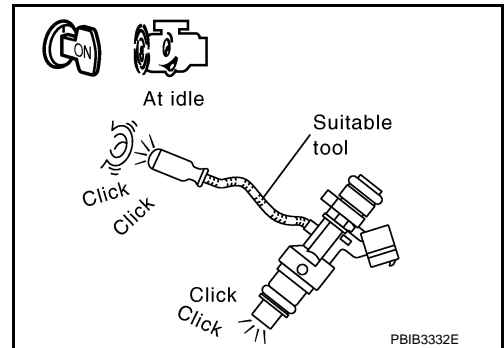

Diagnosis Procedure

INFOID:000000004833518

1. CHECK FUEL INJECTOR POWER SUPPLY CIRCUIT

1. Turn ignition switch OFF.
2. Disconnect fuel injector harness connector.
3. Turn ignition switch ON.
4. Check the voltage between fuel injector harness connector and ground.

FUEL INJECTOR

[MR18DE]

< DTC/CIRCUIT DIAGNOSIS >

Fuel injector			Ground	Voltage
Cylinder	Connector	Terminal		
1	F37	1	Ground	Battery voltage
2	F38	1		
3	F39	1		
4	F40	1		

Is the inspection result normal?

- YES >> GO TO 3.
NO >> GO TO 2.

2. DETECT MALFUNCTIONING PART

Check the following.

- IPDM E/R harness connector E15
- 15 A fuse (No. 62)
- Harness for open or short between fuel injector and fuse

>> Repair open circuit or short to ground or short to power in harness or connectors.

3. CHECK FUEL INJECTOR OUTPUT SIGNAL CIRCUIT FOR OPEN AND SHORT

1. Turn ignition switch OFF.
2. Disconnect ECM harness connector.
3. Check the continuity between fuel injector harness connector and ECM harness connector.

Fuel injector			ECM		Continuity
Cylinder	Connector	Terminal	Connector	Terminal	
1	F37	2	F7	31	Existed
2	F38	2		30	
3	F39	2		29	
4	F40	2		25	

4. Also check harness for short to ground and short to power.

Is the inspection result normal?

- YES >> GO TO 4.
NO >> Repair open circuit or short to ground or short to power in harness or connectors.

4. CHECK FUEL INJECTOR

Refer to [EC-396, "Component Inspection"](#).

Is the inspection result normal?

- YES >> GO TO 5.
NO >> Replace malfunctioning fuel injector.

5. CHECK INTERMITTENT INCIDENT

Refer to [GI-34, "Intermittent Incident"](#).

Is the inspection result normal?

- YES >> Replace IPDM E/R.
NO >> Repair open circuit or short to ground or short to power in harness or connectors.

Component Inspection

INFOID:000000004833519

1. CHECK FUEL INJECTOR

1. Turn ignition switch OFF.
2. Disconnect fuel injector harness connector.
3. Check resistance between fuel injector terminals as per the following.

FUEL INJECTOR

< DTC/CIRCUIT DIAGNOSIS >

[MR18DE]

Terminals	Resistance
1 and 2	11.1 - 14.5 Ω [at 10 - 60°C (50 - 140°F)]

Is the inspection result normal?

- YES >> INSPECTION END
- NO >> Replace malfunctioning fuel injector.

A

EC

C

D

E

F

G

H

I

J

K

L

M

N

O

P

FUEL PUMP

< DTC/CIRCUIT DIAGNOSIS >

[MR18DE]

FUEL PUMP

Description

INFOID:000000004833520

Sensor	Input signal to ECM	ECM function	Actuator
Crankshaft position sensor (POS) Camshaft position sensor (PHASE)	Engine speed*	Fuel pump control	Fuel pump relay ↓
Battery	Battery voltage*		Fuel pump

*: ECM determines the start signal status by the signals of engine speed and battery voltage.

The ECM activates the fuel pump for several seconds after the ignition switch is turned ON to improve engine start ability. If the ECM receives a engine speed signal from the camshaft position sensor (PHASE), it knows that the engine is rotating, and causes the pump to operate. If the engine speed signal is not received when the ignition switch is ON, the engine stalls. The ECM stops pump operation and prevents battery discharging, thereby improving safety. The ECM does not directly drive the fuel pump. It controls the ON/OFF fuel pump relay, which in turn controls the fuel pump.

Condition	Fuel pump operation
Ignition switch is turned to ON.	Operates for 1 second.
Engine running and cranking	Operates.
When engine is stopped	Stops in 1.5 seconds.
Except as shown above	Stops.

Component Function Check

INFOID:000000004833521

1. CHECK FUEL PUMP FUNCTION

1. Turn ignition switch ON.
2. Pinch fuel feed hose (1) with two fingers.

Fuel pressure pulsation should be felt on the fuel feed hose for 1 second after ignition switch is turned ON.

Is the inspection result normal?

- YES >> INSPECTION END
NO >> [EC-398, "Diagnosis Procedure"](#).

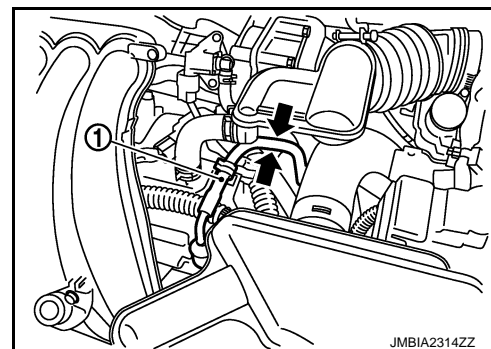

Diagnosis Procedure

INFOID:000000004833523

1. CHECK FUEL PUMP POWER SUPPLY CIRCUIT-I

1. Turn ignition switch OFF.
2. Disconnect ECM harness connector.
3. Turn ignition switch ON.
4. Check the voltage between ECM harness connector and ground.

ECM		Ground	Voltage
Connector	Terminal		
F7	23	Ground	Battery voltage

Is the inspection result normal?

- YES >> GO TO 4.
NO >> GO TO 2.

2. CHECK FUEL PUMP POWER SUPPLY CIRCUIT-II

FUEL PUMP

[MR18DE]

< DTC/CIRCUIT DIAGNOSIS >

1. Turn ignition switch OFF.
2. Disconnect IPDM E/R harness connector E13.
3. Turn ignition switch ON.
4. Check the voltage between IPDM E/R harness connector and ground.

IPDM E/R		Ground	Voltage
Connector	Terminal		
E13	31	Ground	Battery voltage

Is the inspection result normal?

- YES >> GO TO 4.
NO >> GO TO 3.

3.DETECT MALFUNCTIONING PART

Check the following.

- Harness or connectors E8, F1
- Harness for open or short between ECM and IPDM E/R

>> Repair open circuit or short to ground or short to power in harness or connectors.

4.CHECK FUEL PUMP POWER SUPPLY CIRCUIT-III

1. Turn ignition switch OFF.
2. Reconnect all harness connectors disconnected.
3. Disconnect "fuel level sensor unit and fuel pump" harness connector.
4. Turn ignition switch ON.
5. Check the voltage between "fuel level sensor unit and fuel pump" harness connector and ground.

Fuel level sensor unit and fuel pump		Ground	Voltage
Connector	Terminal		
B40	1	Ground	Battery voltage should exist 1 second after ignition switch is turn ON.

Is the inspection result normal?

- YES >> GO TO 8.
NO >> GO TO 5.

5.CHECK FUSE

1. Turn ignition switch OFF.
2. Disconnect 15 A fuse (No. 60) from IPDM E/R.
3. Check 15 A fuse.

Is the inspection result normal?

- YES >> GO TO 6.
NO >> Replace 15 A fuse.

6.CHECK FUEL PUMP POWER SUPPLY CIRCUIT-IV

1. Disconnect IPDM E/R harness connector E15.
2. Check the continuity between IPDM E/R harness connector and "fuel level sensor unit and fuel pump" harness connector.

IPDM E/R		Fuel level sensor unit and fuel pump		Continuity
Connector	Terminal	Connector	Terminal	
E15	36	B40	1	Existed

3. Also check harness for short to ground and short to power.

Is the inspection result normal?

- YES >> GO TO 10.
NO >> GO TO 7.

FUEL PUMP

[MR18DE]

< DTC/CIRCUIT DIAGNOSIS >

7. DETECT MALFUNCTIONING PART

Check the following.

- Harness connectors B1, M18
- Harness connectors M77, E105
- Harness for open or short between IPDM E/R and “fuel level sensor unit and fuel pump”

>> Repair open circuit or short to power in harness or connectors.

8. CHECK FUEL PUMP GROUND CIRCUIT

1. Check the continuity between “fuel level sensor unit and fuel pump” and ground.

Fuel level sensor unit and fuel pump		Ground	Continuity
Connector	Terminal		
B40	3	Ground	Existed

2. Also check harness for short to power.

Is the inspection result normal?

YES >> GO TO 9.

NO >> Repair open circuit or short to power in harness or connectors.

9. CHECK FUEL PUMP

Refer to [EC-400, "Component Inspection"](#).

Is the inspection result normal?

YES >> GO TO 10.

NO >> Replace “fuel level sensor unit and fuel pump”.

10. CHECK INTERMITTENT INCIDENT

Refer to [GI-34, "Intermittent Incident"](#).

Is the inspection result normal?

YES >> Replace IPDM E/R.

NO >> Repair or replace harness or connectors.

Component Inspection

INFOID:000000004833524

1. CHECK FUEL PUMP

1. Turn ignition switch OFF.
2. Disconnect “fuel level sensor unit and fuel pump” harness connector.
3. Check resistance between “fuel level sensor unit and fuel pump” terminals as per the following.

Terminals	Resistance
1 and 3	0.2 - 5.0 Ω [at 25°C (77°F)]

Is the inspection result normal?

YES >> INSPECTION END

NO >> Replace “fuel level sensor unit and fuel pump”.

IGNITION SIGNAL

Description

INFOID:000000004833525

The ignition signal from the ECM is sent to and amplified by the power transistor. The power transistor turns ON and OFF the ignition coil primary circuit. This ON/OFF operation induces the proper high voltage in the coil secondary circuit.

Component Function Check

INFOID:000000004833526

1.INSPECTION START

Turn ignition switch OFF, and restart engine.

Does the engine start?

YES-1 >> With CONSULT-III: GO TO 2.

YES-2 >> Without CONSULT-III: GO TO 3.

NO >> Go to [EC-401, "Diagnosis Procedure"](#).

2.IGNITION SIGNAL FUNCTION

With CONSULT-III

1. Perform "POWER BALANCE" in "ACTIVE TEST" mode with CONSULT-III.
2. Make sure that each circuit produces a momentary engine speed drop.

Is the inspection result normal?

YES >> INSPECTION END

NO >> Go to [EC-401, "Diagnosis Procedure"](#).

3.IGNITION SIGNAL FUNCTION

Without CONSULT-III

1. Let engine idle.
2. Read the voltage signal between ECM harness connector and ground.

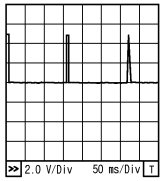
ECM		Ground	Voltage signal
Connector	Terminal		
F10	17	Ground	
	18		
	21		
	22		

NOTE:

The pulse cycle changes depending on rpm at idle.

Is the inspection result normal?

YES >> INSPECTION END

NO >> Go to [EC-401, "Diagnosis Procedure"](#).

Diagnosis Procedure

INFOID:000000004833528

1.CHECK IGNITION COIL POWER SUPPLY CIRCUIT-I

1. Turn ignition switch OFF, wait at least 10 seconds and then turn ON.
2. Check the voltage between ECM harness connector and ground.

ECM		Ground	Voltage
Connector	Terminal		
E16	105	Ground	Battery voltage

IGNITION SIGNAL

[MR18DE]

< DTC/CIRCUIT DIAGNOSIS >

Is the inspection result normal?

- YES >> GO TO 2.
NO >> Go to [EC-117, "Diagnosis Procedure"](#).

2.CHECK IGNITION COIL POWER SUPPLY CIRCUIT-II

1. Turn ignition switch OFF.
2. Disconnect Condenser harness connector.
3. Turn ignition switch ON.
4. Check the voltage between condenser harness connector and ground.

Condenser		Ground	Voltage
Connector	Terminal		
F13	1	Ground	Battery voltage

Is the inspection result normal?

- YES >> GO TO 5.
NO >> GO TO 3.

3.CHECK IGNITION COIL POWER SUPPLY CIRCUIT-III

1. Turn ignition switch OFF.
2. Disconnect IPDM E/R harness connector E43.
3. Check the continuity between IPDM E/R harness connector and condenser harness connector.

IPDM E/R		Condenser		Continuity
Connector	Terminal	Connector	Terminal	
E14	44	F26	1	Existed

4. Also check harness for short to ground and short to power.

Is the inspection result normal?

- YES >> Go to [EC-117, "Diagnosis Procedure"](#).
NO >> GO TO 4.

4.DETECT MALFUNCTIONING PART

Check the following.

- Harness connectors E8, F1
- IPDM E/R harness connector E43
- Harness for open or short between IPDM E/R and condenser

>> Repair open circuit or short to ground or short to power in harness or connectors.

5.CHECK CONDENSER GROUND CIRCUIT FOR OPEN AND SHORT

1. Turn ignition switch OFF.
2. Check the continuity between Condenser harness connector and ground.

Condenser		Ground	Continuity
Connector	Terminal		
E13	2	Ground	Existed

3. Also check harness for short to power.

Is the inspection result normal?

- YES >> GO TO 6.
NO >> Repair open circuit or short to ground or short to power in harness or connectors.

6.CHECK CONDENSER

Refer to [EC-405, "Component Inspection \(Condenser\)"](#).

Is the inspection result normal?

- YES >> GO TO 7.

IGNITION SIGNAL

[MR18DE]

< DTC/CIRCUIT DIAGNOSIS >

NO >> Replace condenser.

7. CHECK IGNITION COIL POWER SUPPLY CIRCUIT-V

1. Reconnect all harness connectors disconnected.
2. Disconnect ignition coil harness connector.
3. Turn ignition switch ON.
4. Check the voltage between ignition coil harness connector and ground.

Ignition coil			Ground	Voltage
Cylinder	Connector	Terminal		
1	F33	3	Ground	Battery voltage
2	F34	3		
3	F35	3		
4	F36	3		

Is the inspection result normal?

YES >> GO TO 8.

NO >> Repair open circuit or short to ground or short to power in harness or connectors.

8. CHECK IGNITION COIL GROUND CIRCUIT FOR OPEN AND SHORT

1. Turn ignition switch OFF.
2. Check the continuity between ignition coil harness connector and ground.

Ignition coil			Ground	Continuity
Cylinder	Connector	Terminal		
1	F33	2	Ground	Existed
2	F34	2		
3	F35	2		
4	F36	2		

3. Also check harness for short to power.

Is the inspection result normal?

YES >> GO TO 9.

NO >> Repair open circuit or short to ground or short to power in harness or connectors.

9. CHECK IGNITION COIL OUTPUT SIGNAL CIRCUIT FOR OPEN AND SHORT

1. Disconnect ECM harness connector.
2. Check the continuity between ECM harness connector and ignition coil harness connector.

Ignition coil			ECM		Continuity
Cylinder	Connector	Terminal	Connector	Terminal	
1	F33	1	F7	17	Existed
2	F34	1		18	
3	F35	1		22	
4	F36	1		21	

3. Also check harness for short to ground and short to power.

Is the inspection result normal?

YES >> GO TO 10.

NO >> Repair open circuit or short to ground or short to power in harness or connectors.

10. CHECK IGNITION COIL WITH POWER TRANSISTOR

Refer to [EC-404. "Component Inspection \(Ignition Coil with Power Transistor\)".](#)

Is the inspection result normal?

YES >> GO TO 11.

IGNITION SIGNAL

[MR18DE]

< DTC/CIRCUIT DIAGNOSIS >

NO >> Replace malfunctioning ignition coil with power transistor.

11.CHECK INTERMITTENT INCIDENT

Refer to [GI-34, "Intermittent Incident"](#).

>> INSPECTION END

Component Inspection (Ignition Coil with Power Transistor)

INFOID:000000004833529

1.CHECK IGNITION COIL WITH POWER TRANSISTOR-I

1. Turn ignition switch OFF.
2. Disconnect ignition coil harness connector.
3. Check resistance between ignition coil terminals as per the following.

Terminals	Resistance [Ω at 25°C (77°F)]
1 and 2	Except 0 or ∞
1 and 3	Except 0
2 and 3	

Is the inspection result normal?

YES >> GO TO 2.

NO >> Replace malfunctioning ignition coil with power transistor.

2.CHECK IGNITION COIL WITH POWER TRANSISTOR-II

CAUTION:

Do the following procedure in the place where ventilation is good without the combustible.

1. Turn ignition switch OFF.
2. Reconnect all harness connectors disconnected.
3. Remove fuel pump fuse in IPDM E/R to release fuel pressure.

NOTE:

Do not use CONSULT-III to release fuel pressure, or fuel pressure applies again during the following procedure.

4. Start engine.
5. After engine stalls, crank it two or three times to release all fuel pressure.
6. Turn ignition switch OFF.
7. Remove all ignition coil harness connectors to avoid the electrical discharge from the ignition coils.
8. Remove ignition coil and spark plug of the cylinder to be checked.
9. Crank engine for 5 seconds or more to remove combustion gas in the cylinder.
10. Connect spark plug and harness connector to ignition coil.
11. Fix ignition coil using a rope etc. with gap of 13 - 17 mm (0.52 - 0.66 in) between the edge of the spark plug and grounded metal portion as shown in the figure.
12. Crank engine for about three seconds, and check whether spark is generated between the spark plug and the grounded metal portion.

Spark should be generated.

CAUTION:

- During the operation, always stay 0.5 cm (19.7 in) away from the spark plug and the ignition coil. Be careful not to get an electrical shock while checking, because the electrical discharge voltage becomes 20 kV or more.
- It might cause to damage the ignition coil if the gap of more than 17 mm (0.66 in) is taken.

NOTE:

When the gap is less than 13 mm (0.52 in), the spark might be generated even if the coil is malfunctioning.

Is the inspection result normal?

YES >> INSPECTION END

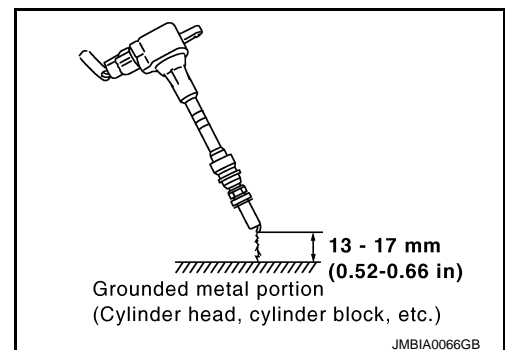

IGNITION SIGNAL

[MR18DE]

< DTC/CIRCUIT DIAGNOSIS >

NO >> Replace malfunctioning ignition coil with power transistor.

Component Inspection (Condenser)

INFOID:000000004833530

1. CHECK CONDENSER

1. Turn ignition switch OFF.
2. Disconnect condenser harness connector.
3. Check resistance between condenser terminals as per the following.

Terminals	Resistance
1 and 2	Above 1 MΩ [at 25°C (77°F)]

Is the inspection result normal?

- YES >> INSPECTION END
NO >> Replace Condenser.

A

EC

C

D

E

F

G

H

I

J

K

L

M

N

O

P

MALFUNCTION INDICATOR LAMP

< DTC/CIRCUIT DIAGNOSIS >

[MR18DE]

MALFUNCTION INDICATOR LAMP

Description

INFOID:000000004833531

The Malfunction Indicator Lamp (MIL) is located on the combination meter.

The MIL will light up when the ignition switch is turned ON without the engine running. This is a bulb check.

When the engine is started, the MIL should go off. If the MIL remains on, the on board diagnostic system has detected an engine system malfunction.

For details, refer to [EC-85. "Diagnosis Description"](#).

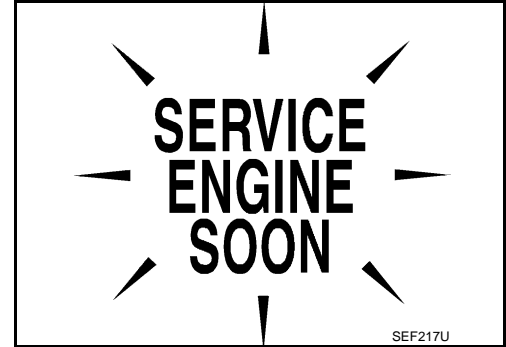

Component Function Check

INFOID:000000004833532

1. CHECK MIL FUNCTION

1. Turn ignition switch ON.
2. Make sure that MIL lights up.

Is the inspection result normal?

- YES >> INSPECTION END
- NO >> Go to [EC-406. "Diagnosis Procedure"](#).

Diagnosis Procedure

INFOID:000000004833534

1. CHECK DTC

Check that DTC UXXXX is not displayed.

Is the inspection result normal?

- YES >> GO TO 2.
- NO >> Perform trouble diagnosis for DTC UXXXX.

2. CHECK DTC WITH METER

Refer to [MWI-30. "CONSULT-III Function \(METER/M&A\)"](#).

Is the inspection result normal?

- YES >> GO TO 3.
- NO >> Repair or replace.

3. CHECK INTERMITTENT INCIDENT

Refer to [GI-34. "Intermittent Incident"](#).

Is the inspection result normal?

- YES >> Replace combination meter.
- NO >> Repair or replace.

ON BOARD REFUELING VAPOR RECOVERY (ORVR)

< DTC/CIRCUIT DIAGNOSIS >

[MR18DE]

ON BOARD REFUELING VAPOR RECOVERY (ORVR)

Description

INFOID:000000004833535

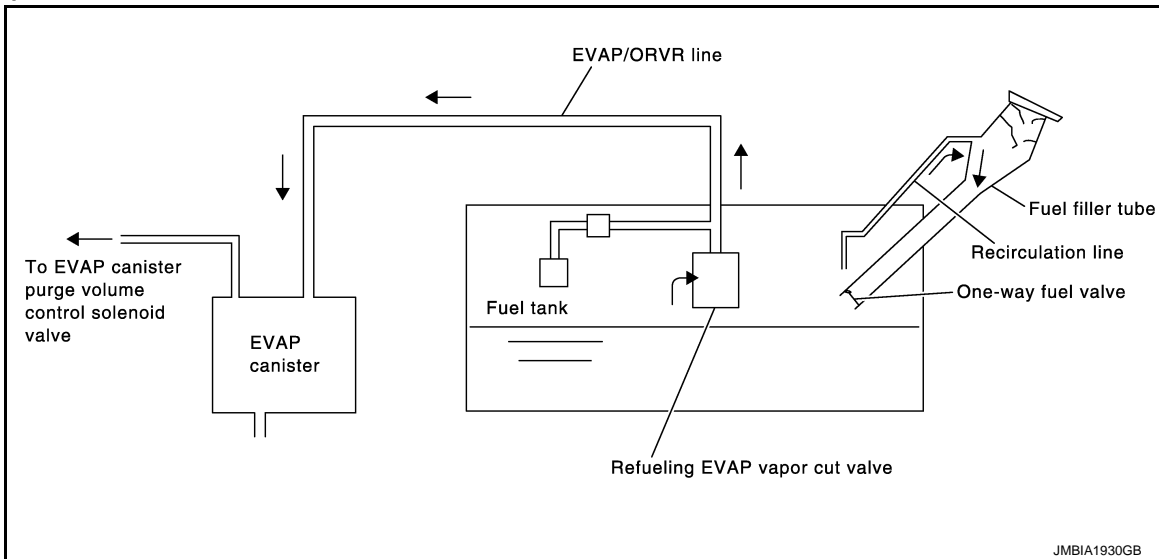

From the beginning of refueling, the air and vapor inside the fuel tank go through refueling EVAP vapor cut valve and EVAP/ORVR line to the EVAP canister. The vapor is absorbed by the EVAP canister and the air is released to the atmosphere.

When the refueling has reached the full level of the fuel tank, the refueling EVAP vapor cut valve is closed and refueling is stopped because of auto shut-off. The vapor which was absorbed by the EVAP canister is purged during driving.

WARNING:

When conducting inspections below, be sure to observe the following:

- Put a "CAUTION: FLAMMABLE" sign in workshop.
- Do not smoke while servicing fuel system. Keep open flames and sparks away from work area.
- Be sure to furnish the workshop with a CO₂ fire extinguisher.

CAUTION:

- Before removing fuel line parts, carry out the following procedures:
 - Put drained fuel in an explosion-proof container and put lid on securely.
 - Release fuel pressure from fuel line. Refer to [EC-471, "Inspection"](#).
 - Disconnect battery ground cable.
- Always replace O-ring when the fuel gauge retainer is removed.
- Do not kink or twist hose and tube when they are installed.
- Do not tighten hose and clamps excessively to avoid damaging hoses.
- After installation, run engine and check for fuel leaks at connection.
- Do not attempt to top off the fuel tank after the fuel pump nozzle shuts off automatically. Continued refueling may cause fuel overflow, resulting in fuel spray and possibly a fire.

Component Function Check

INFOID:000000004833536

1. CHECK ORVR FUNCTION

Check whether the following symptoms are present.

- Fuel odor from EVAP canister is strong.
- Cannot refuel/Fuel odor from the fuel filler opening is strong while refueling.

Is any symptom present?

- YES >> Go to [EC-407, "Diagnosis Procedure"](#).
- NO >> INSPECTION END

Diagnosis Procedure

INFOID:000000004833537

1. INSPECTION START

Check whether the following symptoms are present.

- A: Fuel odor from EVAP canister is strong.

ON BOARD REFUELING VAPOR RECOVERY (ORVR)

[MR18DE]

< DTC/CIRCUIT DIAGNOSIS >

B: Cannot refuel/Fuel odor from the fuel filler opening is strong while refueling.

Which symptom is present?

- A >> GO TO 2.
- B >> GO TO 8.

2.CHECK EVAP CANISTER

1. Remove EVAP canister with EVAP canister vent control valve and EVAP control system pressure sensor attached.
2. Weigh the EVAP canister with EVAP canister vent control valve and EVAP control system pressure sensor attached.

The weight should be less than 1.9 kg (4.2 lb).

Is the inspection result normal?

- YES >> GO TO 3.
- NO >> GO TO 4.

3.CHECK IF EVAP CANISTER IS SATURATED WITH WATER

Check if water will drain from EVAP canister.

Does water drain from the EVAP canister?

- YES >> GO TO 4.
- NO >> GO TO 7.

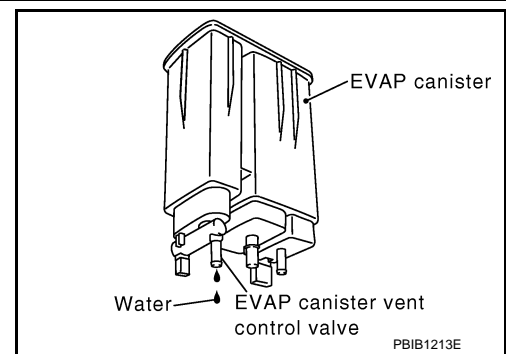

4.REPLACE EVAP CANISTER

Replace EVAP canister with a new one.

>> GO TO 5.

5.CHECK DRAIN FILTER

Refer to [EC-412. "Component Inspection \(Drain filter\)".](#)

Is the inspection result normal?

- OK >> GO TO 6.
- NO >> Replace drain filter.

6.DETECT MALFUNCTIONING PART

Check the EVAP hose between EVAP canister and vehicle frame for clogging or poor connection.

>> Repair or replace EVAP hose.

7.CHECK REFUELING EVAP VAPOR CUT VALVE

Refer to [EC-410. "Component Inspection \(Refueling EVAP vapor cut valve\)".](#)

Is the inspection result normal?

- YES >> INSPECTION END
- NO >> Replace refueling EVAP vapor cut valve with fuel tank.

8.CHECK EVAP CANISTER

1. Remove EVAP canister with EVAP canister vent control valve and EVAP control system pressure sensor attached.
2. Weigh the EVAP canister with EVAP canister vent control valve and EVAP control system pressure sensor attached.

The weight should be less than 1.9 kg (4.2 lb).

Is the inspection result normal?

ON BOARD REFUELING VAPOR RECOVERY (ORVR)

[MR18DE]

< DTC/CIRCUIT DIAGNOSIS >

- YES >> GO TO 9.
- NO >> GO TO 10.

9. CHECK IF EVAP CANISTER IS SATURATED WITH WATER

Check if water will drain from EVAP canister.

Does water drain from the EVAP canister?

- YES >> GO TO 10.
- NO >> GO TO 13.

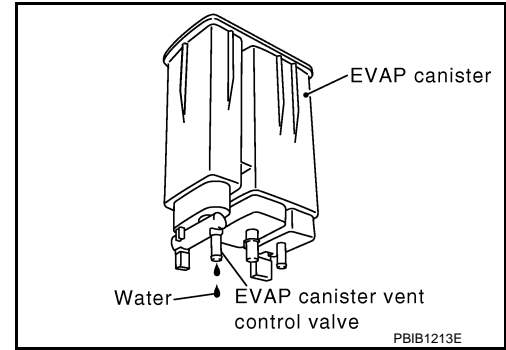

10. REPLACE EVAP CANISTER

Replace EVAP canister with a new one.

>> GO TO 11.

11. CHECK DRAIN FILTER

Refer to [EC-412. "Component Inspection \(Drain filter\)".](#)

Is the inspection result normal?

- OK >> GO TO 12.
- NO >> Replace drain filter.

12. DETECT MALFUNCTIONING PART

Check the EVAP hose between EVAP canister and vehicle frame for clogging or poor connection.

>> Repair or replace EVAP hose.

13. CHECK VENT HOSES AND VENT TUBES

Check hoses and tubes between EVAP canister and refueling control valve for clogging, kink, looseness and improper connection.

Is the inspection result normal?

- YES >> GO TO 14.
- NO >> Repair or replace hoses and tubes.

14. CHECK RECIRCULATION LINE

Check recirculation line for clogging, dents and cracks.

Is the inspection result normal?

- YES >> GO TO 15.
- NO >> Replace fuel filler tube.

15. CHECK REFUELING EVAP VAPOR CUT VALVE

Refer to [EC-410. "Component Inspection \(Refueling EVAP vapor cut valve\)".](#)

Is the inspection result normal?

- YES >> GO TO 16.
- NO >> Replace refueling EVAP vapor cut valve with fuel tank.

16. CHECK FUEL FILLER TUBE

Check fuel filler tube and hose connected to the fuel tank for clogging, dents and cracks.

Is the inspection result normal?

- YES >> GO TO 17.
- NO >> Replace fuel filler tube.

ON BOARD REFUELING VAPOR RECOVERY (ORVR)

< DTC/CIRCUIT DIAGNOSIS >

[MR18DE]

17. CHECK ONE-WAY FUEL VALVE-I

Check one-way valve for clogging.

Is the inspection result normal?

YES >> GO TO 18.

NO >> Repair or replace one-way fuel valve with fuel tank.

18. CHECK ONE-WAY FUEL VALVE-II

1. Make sure that fuel is drained from the tank.
2. Remove fuel filler tube and hose.
3. Check one-way fuel valve for operation as per the following.
When a stick is inserted, the valve should open, when removing stick it should close.

Do not drop any material into the tank.

Is the inspection result normal?

YES >> INSPECTION END

NO >> Replace fuel filler tube or replace one-way fuel valve with fuel tank.

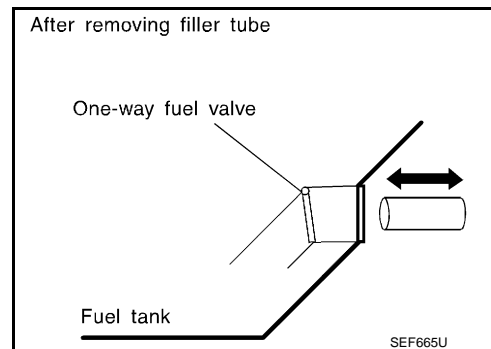

Component Inspection (Refueling EVAP vapor cut valve)

INFOID:000000004833538

1. INSPECTION START

Do you have CONSULT-III?

Do you have CONSULT-III?

YES >> GO TO 2.

NO >> GO TO 3.

2. CHECK REFUELING EVAP VAPOR CUT VALVE

Ⓜ With CONSULT-III

1. Remove fuel tank. Refer to [FL-9, "Removal and Installation"](#).
2. Drain fuel from the tank as per the following:
 - Remove fuel feed hose located on the fuel gauge retainer.
 - Connect a spare fuel hose, one side to fuel gauge retainer where the hose was removed and the other side to a fuel container.
 - Drain fuel using "FUEL PUMP RELAY" in "ACTIVE TEST" mode with CONSULT-III.
3. Check refueling EVAP vapor cut valve for being stuck to close as per the following.
Blow air into the refueling EVAP vapor cut valve (from the end of EVAP/ORVR line hose), and check that the air flows freely into the tank.
4. Check refueling EVAP vapor cut valve for being stuck to open as per the following.
 - Connect vacuum pump to hose end.
 - Remove fuel gauge retainer with fuel gauge unit.

Always replace O-ring with new one.

 - Put fuel tank upside down.
 - Apply vacuum pressure to hose end [-13.3 kPa (-0.136 kg/cm³, -1.93 psi)] with fuel gauge retainer remaining open and check that the pressure is applicable.

ON BOARD REFUELING VAPOR RECOVERY (ORVR)

< DTC/CIRCUIT DIAGNOSIS >

[MR18DE]

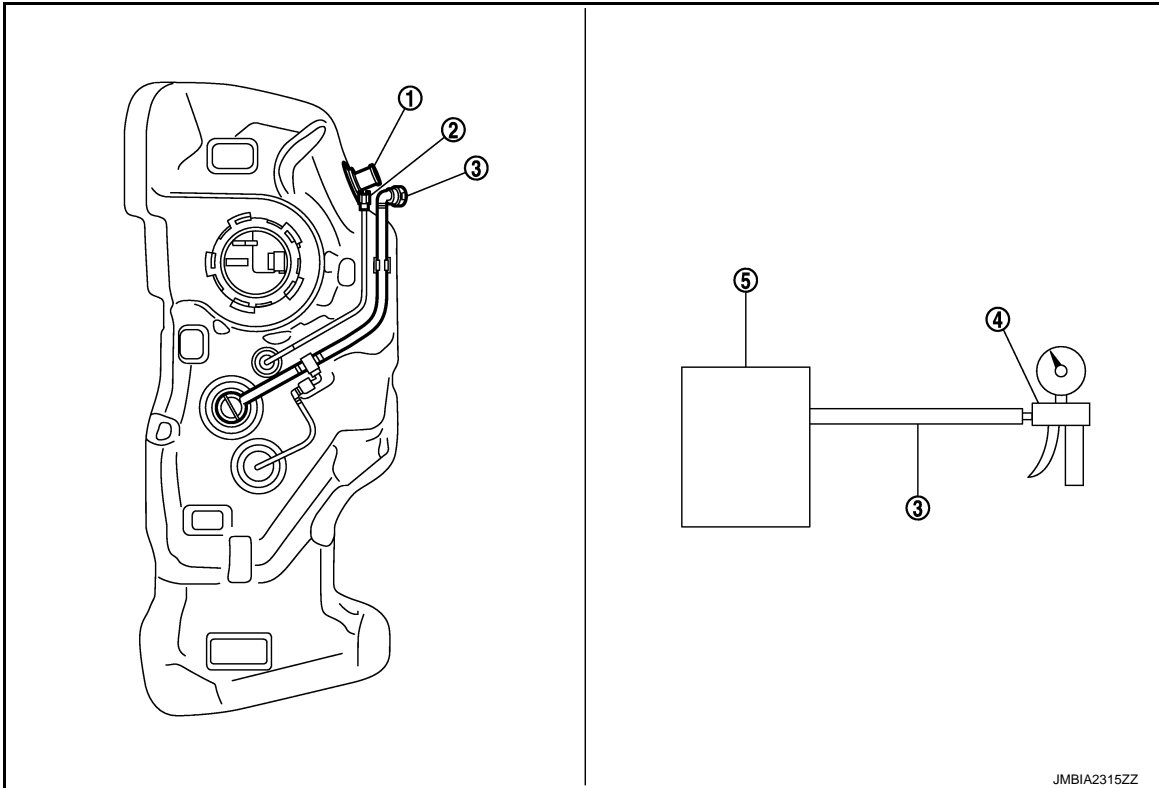

1. Filler tube
2. Recirculation line
3. EVAP/ORVR line
4. Vacuum/pressure handy pump
5. Fuel tank

Is the inspection result normal?

YES >> INSPECTION END

NO >> Replace refueling EVAP vapor cut valve with fuel tank.

3. CHECK REFUELING EVAP VAPOR CUT VALVE

⊗ Without CONSULT-III

1. Remove fuel tank. Refer to [FL-9. "Removal and Installation"](#).
 2. Drain fuel from the tank as per the following:
 - Remove fuel gauge retainer.
 - Drain fuel from the tank using a handy pump into a fuel container.
 3. Check refueling EVAP vapor cut valve for being stuck to close as per the following. Blow air into the refueling EVAP vapor cut valve (from the end of EVAP/ORVR line hose), and check that the air flows freely into the tank.
 4. Check refueling EVAP vapor cut valve for being stuck to open as per the following.
 - Connect vacuum pump to hose end.
 - Remove fuel gauge retainer with fuel gauge unit.
- Always replace O-ring with new one.**
- Put fuel tank upside down.
 - Apply vacuum pressure to hose end [-13.3 kPa (-0.136 kg/cm³, -1.93 psi)] with fuel gauge retainer remaining open and check that the pressure is applicable.

ON BOARD REFUELING VAPOR RECOVERY (ORVR)

< DTC/CIRCUIT DIAGNOSIS >

[MR18DE]

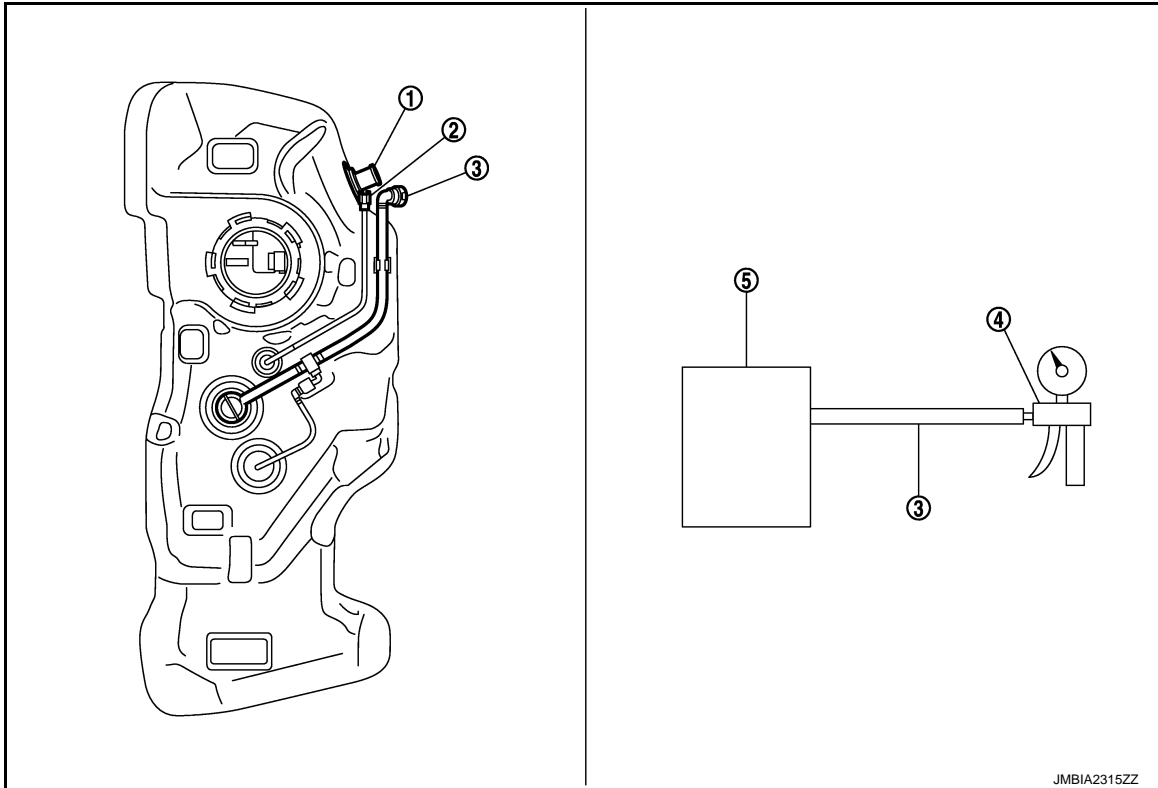

- | | | |
|-------------------------------|-----------------------|-------------------|
| 1. Filler tube | 2. Recirculation line | 3. EVAP/ORVR line |
| 4. Vacuum/pressure handy pump | 5. Fuel tank | |

Is the inspection result normal?

- YES >> INSPECTION END
NO >> Replace refueling EVAP vapor cut valve with fuel tank.

Component Inspection (Drain filter)

INFOID:000000004833539

1. CHECK DRAIN FILTER

1. Check visually for insect nests in the drain filter air inlet.
2. Check visually for cracks or flaws in the appearance.
3. Check visually for cracks or flaws in the hose.
4. Blow air into port A and check that it flows freely out of port B.
5. Block port B.
6. Blow air into port A and check that there is no leakage.

Is the inspection result normal?

- YES >> INSPECTION END
NO >> Replace drain filter.

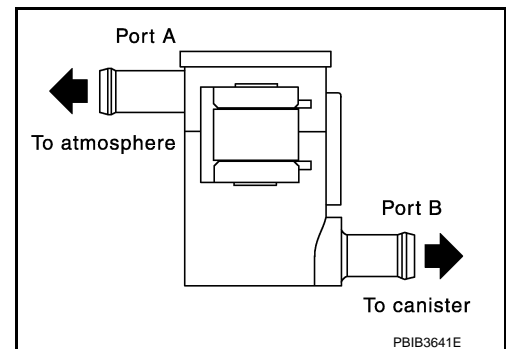

POSITIVE CRANKCASE VENTILATION

< DTC/CIRCUIT DIAGNOSIS >

[MR18DE]

POSITIVE CRANKCASE VENTILATION

Description

INFOID:000000004833540

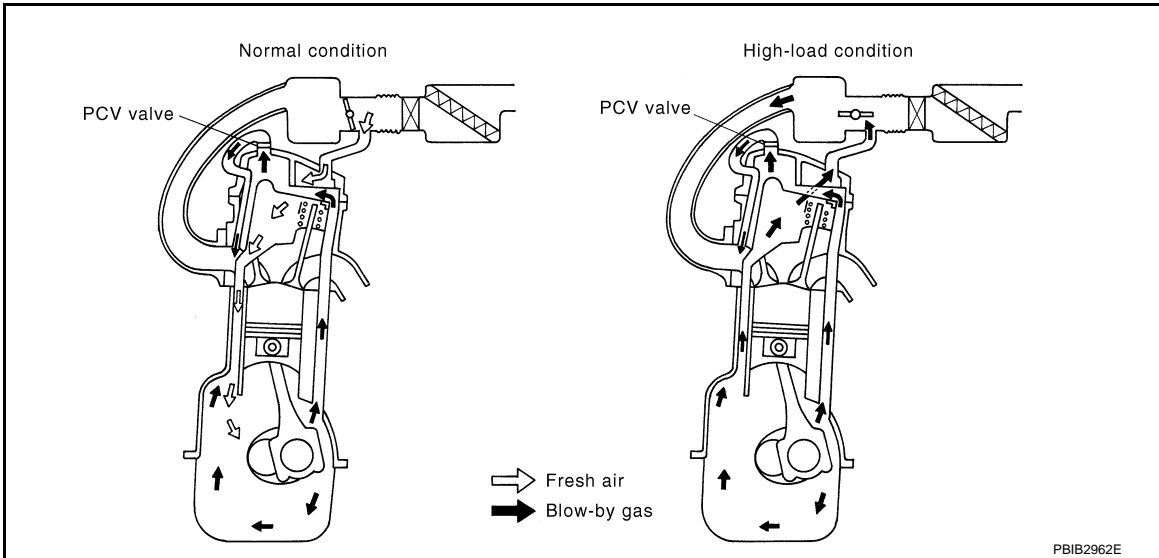

This system returns blow-by gas to the intake manifold.

The positive crankcase ventilation (PCV) valve is provided to conduct crankcase blow-by gas to the intake manifold.

During partial throttle operation of the engine, the intake manifold sucks the blow-by gas through the PCV valve.

Normally, the capacity of the valve is sufficient to handle any blow-by and a small amount of ventilating air.

The ventilating air is drawn from the air inlet tubes into the crankcase. In this process the air passes through the hose connecting air inlet tubes to rocker cover.

Under full-throttle condition, the manifold vacuum is insufficient to draw the blow-by flow through the valve. The flow goes through the hose connection in the reverse direction.

On vehicles with an excessively high blow-by, the valve does not meet the requirement. This is because some of the flow will go through the hose connection to the air inlet tubes under all conditions.

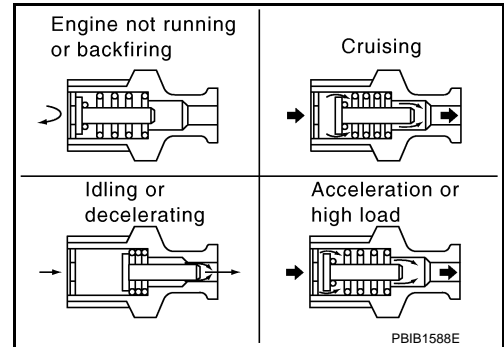

Component Inspection

INFOID:000000004833541

1. CHECK PCV VALVE

With engine running at idle, remove PCV valve from rocker cover. A properly working valve makes a hissing noise as air passes through it. A strong vacuum should be felt immediately when a finger is placed over valve inlet.

Is the inspection result normal?

- YES >> INSPECTION END
- NO >> Replace PCV valve.

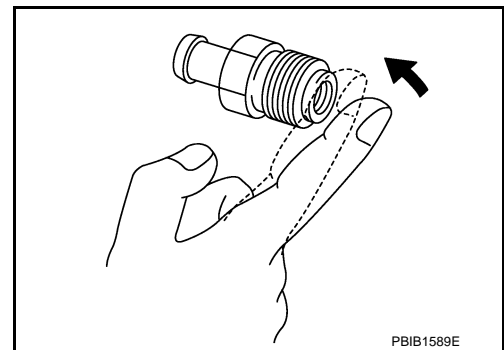

REFRIGERANT PRESSURE SENSOR

< DTC/CIRCUIT DIAGNOSIS >

[MR18DE]

REFRIGERANT PRESSURE SENSOR

Description

INFOID:000000004833542

The refrigerant pressure sensor is installed at the condenser of the air conditioner system. The sensor uses an electrostatic volume pressure transducer to convert refrigerant pressure to voltage. The voltage signal is sent to ECM, and ECM controls cooling fan system.

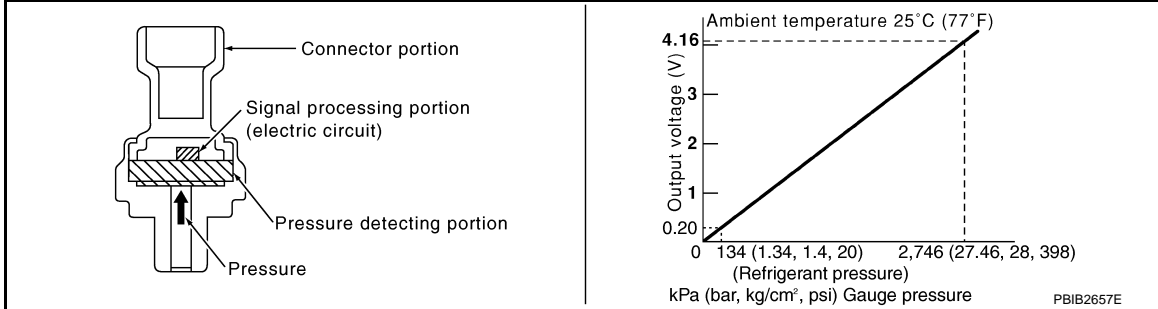

Component Function Check

INFOID:000000004833543

1. CHECK REFRIGERANT PRESSURE SENSOR OVERALL FUNCTION

1. Start engine and warm it up to normal operating temperature.
2. Turn A/C switch and blower fan switch ON.
3. Check the voltage between ECM harness connector and ground.

ECM		Ground	Voltage
Connector	Terminal		
F8	41 (Refrigerant pressure sensor signal)	Ground	1.0 - 4.0V

Is the inspection result normal?

- YES >> INSPECTION END
 NO >> Go to [EC-414, "Diagnosis Procedure"](#).

Diagnosis Procedure

INFOID:000000004833545

1. CHECK GROUND CONNECTION

1. Turn A/C switch and blower fan switch OFF.
2. Stop engine.
3. Turn ignition switch OFF.
4. Check ground connection E38. Refer to [GI-37, "Circuit Inspection"](#).

Is the inspection result normal?

- YES >> GO TO 2.
 NO >> Repair or replace ground connection.

2. CHECK REFRIGERANT PRESSURE SENSOR POWER SUPPLY CIRCUIT

1. Disconnect refrigerant pressure sensor harness connector.
2. Turn ignition switch ON.
3. Check the voltage between refrigerant pressure sensor harness connector and ground.

Refrigerant pressure sensor		Ground	Voltage
Connector	Terminal		
E49	3	Ground	Approx. 5 V

Is the inspection result normal?

- YES >> GO TO 4.

REFRIGERANT PRESSURE SENSOR

[MR18DE]

< DTC/CIRCUIT DIAGNOSIS >

NO >> GO TO 3.

3. DETECT MALFUNCTIONING PART

Check the following.

- Harness connectors F1, E8
- Harness for open or short between ECM and refrigerant pressure sensor

>> Repair open circuit or short to ground or short to power in harness or connectors.

4. CHECK REFRIGERANT PRESSURE SENSOR GROUND CIRCUIT FOR OPEN AND SHORT

1. Turn ignition switch OFF.
2. Disconnect ECM harness connector.
3. Check the continuity between refrigerant pressure sensor harness connector and ECM harness connector.

Refrigerant pressure sensor		ECM		Continuity
Connector	Terminal	Connector	Terminal	
E49	1	F8	48	Existed

4. Also check harness for short to ground and short to power.

Is the inspection result normal?

YES >> GO TO 6.

NO >> GO TO 5.

5. DETECT MALFUNCTIONING PART

Check the following.

- Harness connectors E8, F1
- Harness for open or short between ECM and refrigerant pressure sensor

>> Repair open circuit or short to ground or short to power in harness or connectors.

6. CHECK REFRIGERANT PRESSURE SENSOR INPUT SIGNAL CIRCUIT FOR OPEN AND SHORT

1. Check the continuity between ECM harness connector and refrigerant pressure sensor harness connector.

Refrigerant pressure sensor		ECM		Continuity
Connector	Terminal	Connector	Terminal	
E49	2	F8	41	Existed

2. Also check harness for short to ground and short to power.

Is the inspection result normal?

YES >> GO TO 8.

NO >> GO TO 7.

7. DETECT MALFUNCTIONING PART

Check the following.

- Harness connectors E8, F1
- Harness for open or short between ECM and refrigerant pressure sensor

>> Repair open circuit or short to ground or short to power in harness or connectors.

8. CHECK INTERMITTENT INCIDENT

Refer to [GI-34. "Intermittent Incident"](#).

Is the inspection result normal?

YES >> Replace refrigerant pressure sensor.

NO >> Repair or replace.

ECU DIAGNOSIS INFORMATION

ECM

Reference Value

INFOID:000000005040138

VALUES ON THE DIAGNOSIS TOOL

Remarks:

- Specification data are reference values.
- Specification data are output/input values which are detected or supplied by the ECM at the connector.

*Specification data may not be directly related to their components signals/values/operations.

I.e. Adjust ignition timing with a timing light before monitoring IGN TIMING, because the monitor may show the specification data in spite of the ignition timing not being adjusted to the specification data. this IGN TIMING monitors the data calculated by the ECM according to the signals input from the camshaft position sensor and other ignition timing related sensors.

Monitor Item	Condition		Values/Status
ENG SPEED	• Run engine and compare CONSULT-III value with the tachometer indication.		Almost the same speed as the tachometer indication.
MAS A/F SE-B1	See EC-110. "Diagnosis Procedure" .		
B/FUEL SCHDL	See EC-110. "Diagnosis Procedure" .		
A/F ALPHA-B1	See EC-110. "Diagnosis Procedure" .		
COOLAN TEMP/S	• Engine: After warming up		More than 70°C (158F)
A/F SEN1 (B1)	• Engine: After warming up	Maintaining engine speed at 2,000 rpm	Fluctuates around 2.2 V
HO2S2 (B1)	• Revving engine from idle up to 3,000 rpm quickly after the following conditions are met.		0 - 0.3 V ←→ Approx. 0.6 - 1.0 V
HO2S2 MNTR (B1)	- Engine: After warming up - After keeping engine speed between 3,500 and 4,000 rpm for 1 minute and at idle for 1 minute under no load		LEAN ←→ RICH
VHCL SPEED SE	• Turn drive wheels and compare CONSULT-III value with the speedometer indication.		Almost the same speed as speedometer indication
BATTERY VOLT	• Ignition switch: ON (Engine stopped)		11 - 14 V
ACCEL SEN 1	• Ignition switch: ON (Engine stopped)	Accelerator pedal: Fully released	0.6 - 0.9 V
		Accelerator pedal: Fully depressed	4.0 - 4.8 V
ACCEL SEN 2*1	• Ignition switch: ON (Engine stopped)	Accelerator pedal: Fully released	0.6 - 0.9 V
		Accelerator pedal: Fully depressed	3.9 - 4.8 V
TP SEN 1-B1	• Ignition switch: ON (Engine stopped) • Selector lever position: D (CVT) or 1st (M/T)	Accelerator pedal: Fully released	More than 0.36 V
		Accelerator pedal: Fully depressed	Less than 4.75 V
TP SEN 2-B1*1	• Ignition switch: ON (Engine stopped) • Selector lever position: D (CVT) or 1st (M/T)	Accelerator pedal: Fully released	More than 0.36 V
		Accelerator pedal: Fully depressed	Less than 4.75 V
START SIGNAL	• Ignition switch: ON → START → ON		OFF → ON → OFF
CLSD THL POS	• Ignition switch: ON (Engine stopped)	Accelerator pedal: Fully released	ON
		Accelerator pedal: Slightly depressed	OFF
AIR COND SIG	• Engine: After warming up, idle the engine	Air conditioner switch: OFF	OFF
		Air conditioner switch: ON (Compressor operates.)	ON
P/N POSI SW	• Ignition switch: ON	Selector lever position: P or N (CVT) or Neutral (M/T)	ON
		Selector lever position: Except above	OFF

ECM

< ECU DIAGNOSIS INFORMATION >

[MR18DE]

Monitor Item	Condition	Values/Status	
PW/ST SIGNAL	<ul style="list-style-type: none"> Engine: After warming up, idle the engine 	Steering wheel: Not being turned	OFF
		Steering wheel: Being turned	ON
LOAD SIGNAL	<ul style="list-style-type: none"> Ignition switch: ON 	Rear window defogger switch: ON and/or Lighting switch: 2nd position	ON
		Rear window defogger switch and lighting switch: OFF	OFF
IGNITION SW	<ul style="list-style-type: none"> Ignition switch: ON → OFF → ON 		ON → OFF → ON
HEATER FAN SW	<ul style="list-style-type: none"> Engine: After warming up, idle the engine 	Heater fan switch: ON	ON
		Heater fan switch: OFF	OFF
BRAKE SW	<ul style="list-style-type: none"> Ignition switch: ON 	Brake pedal: Fully released	OFF
		Brake pedal: Slightly depressed	ON
INJ PULSE-B1	<ul style="list-style-type: none"> Engine: After warming up Selector lever position: P or N (CVT) or Neutral (M/T) Air conditioner switch: OFF No load 	Idle	2.0 - 3.0 msec
		2,000 rpm	1.9 - 2.9 msec
IGN TIMING	<ul style="list-style-type: none"> Engine: After warming up Selector lever position: P or N (CVT) or Neutral (M/T) Air conditioner switch: OFF No load 	Idle	8 - 18°BTDC
		2,000 rpm	25 - 45°BTDC
CAL/LD VALUE	<ul style="list-style-type: none"> Engine: After warming up Selector lever position: P or N (CVT) or Neutral (M/T) Air conditioner switch: OFF No load 	Idle	10 - 35%
		2,500 rpm	10 - 35%
MASS AIRFLOW	<ul style="list-style-type: none"> Engine: After warming up Selector lever position: P or N (CVT) or Neutral (M/T) Air conditioner switch: OFF No load 	Idle	1.0 - 4.0 g·m/s
		2,500 rpm	2.0 - 10.0 g·m/s
PURG VOL C/V	<ul style="list-style-type: none"> Engine: After warming up Selector lever position: P or N (CVT) or Neutral (M/T) Air conditioner switch: OFF No load 	Idle	0%
		2,000 rpm	0 - 50%
INT/V TIM (B1)	<ul style="list-style-type: none"> Engine: After warming up Selector lever position: P or N (CVT) or Neutral (M/T) Air conditioner switch: OFF No load 	Idle	-5 - 5°C
		2,000 rpm	Approx. 0 - 40°C
INT/V SOL (B1)	<ul style="list-style-type: none"> Engine: After warming up Selector lever position: P or N (CVT) or Neutral (M/T) Air conditioner switch: OFF No load 	Idle	0 - 2%
		2,000 rpm	Approx. 0 - 90%
AIR COND RLY	<ul style="list-style-type: none"> Engine: After warming up, idle the engine 	Air conditioner switch: OFF	OFF
		Air conditioner switch: ON (Compressor operates)	ON
FUEL PUMP RLY	<ul style="list-style-type: none"> For 1 second after turning ignition switch: ON Engine running or cranking 		ON
	<ul style="list-style-type: none"> Except above 		OFF
THRTL RELAY	<ul style="list-style-type: none"> Ignition switch: ON 		ON

A

EC

C

D

E

F

G

H

I

J

K

L

M

N

O

P

ECM

< ECU DIAGNOSIS INFORMATION >

[MR18DE]

Monitor Item	Condition		Values/Status
COOLING FAN	<ul style="list-style-type: none"> Engine: After warming up, idle the engine Air conditioner switch: OFF 	Engine coolant temperature is 98°C (208°F) or less	OFF
		Engine coolant temperature is between 98°C (208°F) and 99°C (210°F)	LOW
		Engine coolant temperature is 100°C (212°F) or more	HIGH
HO2S2 HTR (B1)	<ul style="list-style-type: none"> Engine speed: Below 3,600 rpm after the following conditions are met. <ul style="list-style-type: none"> Engine: After warming up Keeping the engine speed between 3,500 and 4,000 rpm for 1 minute and at idle for 1 minute under no load 		ON
VEHICLE SPEED	<ul style="list-style-type: none"> Turn drive wheels and compare CONSULT-III value with the speedometer indication. 		Almost the same speed as the speedometer indication
IDL A/V LEARN	<ul style="list-style-type: none"> Engine: running 	Idle air volume learning has not been performed yet.	YET
		Idle air volume learning has already been performed successfully.	CMPLT
TRVL AFTER MIL	<ul style="list-style-type: none"> Ignition switch: ON 	Vehicle has traveled after MIL has turned ON.	0 - 65,535 km (0 - 40,723 miles)
A/F S1 HTR (B1)	<ul style="list-style-type: none"> Engine: After warming up, idle the engine (More than 140 seconds after starting engine) 		4 - 100%
AC PRESS SEN	<ul style="list-style-type: none"> Engine: Idle Both A/C switch and blower fan switch: ON (Compressor operates) 		1.0 - 4.0 V
EVAP SYS PRES	<ul style="list-style-type: none"> Ignition switch: ON 		Approx 1.8 - 4.8 V
VENT CONT/V	<ul style="list-style-type: none"> Ignition switch: ON 		OFF
I/P PULLY SPD	<ul style="list-style-type: none"> Vehicle speed: More than than 20 km/h (12MPH) 		Almost the same speed as the tachometer indication.
A/F ADJ-B1	<ul style="list-style-type: none"> Engine: Running 		-0.330 - 0.330
FUEL T/TMP SE	<ul style="list-style-type: none"> Ignition switch: ON 		Indicates fuel tank temperature.
INT/A TEMP SE	<ul style="list-style-type: none"> Ignition switch: ON 		Indicates intake air temperature.
FUEL LEVEL SE	<ul style="list-style-type: none"> Ignition switch: ON 		Depending on fuel level of fuel tank.
BAT CUR SEN	<ul style="list-style-type: none"> Engine speed: Idle Battery: Fuel charged*2 Selector lever: P or N (CVT), Neutral (M/T) Air conditioner switch: OFF No load 		Approx 2,600 - 3,500 mV
ALT DUTY	<ul style="list-style-type: none"> Engine: Idle 		0 - 80%
ALT DUTY SIG	<ul style="list-style-type: none"> Power generation voltage variable control: Operating 		ON
	<ul style="list-style-type: none"> Power generation voltage variable control: Not operating 		OFF
VHCL SPEED SE	<ul style="list-style-type: none"> Turn drive wheels and compare CONSULT-III value with the speedometer indication. 		Almost the same speed as the speedometer indication.
SET VHCL SPD	<ul style="list-style-type: none"> Engine: Running 	ASCD: Operating	The preset vehicle speed is displayed.
MAIN SW	<ul style="list-style-type: none"> Ignition switch: ON 	MAIN switch: pressed	ON
		MAIN switch: Released	OFF
CANCEL SW	<ul style="list-style-type: none"> Ignition switch: ON 	CANCEL switch: pressed	ON
		CANCEL switch: Released	OFF
SET SW	<ul style="list-style-type: none"> Ignition switch: ON 	SET/COAST switch: pressed	ON
		SET/COAST switch: Released	OFF

< ECU DIAGNOSIS INFORMATION >

Monitor Item	Condition	Values/Status	
RESUME/ACC SW	• Ignition switch: ON	RESUME/ACCELERATE switch: pressed	ON
		RESUME/ACCELERATE switch: Released	OFF
BRAKE SW1 (ASCD brake switch)	• Ignition switch: ON	• Brake pedal: Fully released (CVT) • Brake pedal and clutch pedal: Fully released (M/T)	ON
		• Brake pedal: Slightly depressed (CVT) • Brake pedal and/or clutch pedal: Slightly depressed (M/T)	OFF
BRAKE SW2 (stop lamp switch)	• Ignition switch: ON	Brake pedal: Fully released	OFF
		Brake pedal: Slightly depressed	ON
VHCL SPD CUT	• Ignition switch: ON	NON	
LO SPEED CUT	• Ignition switch: ON	NON	
AT OD MONITOR	• Ignition switch: ON	OFF	
AT OD CANCEL	• Ignition switch: ON	OFF	
CRUISE LAMP	• Ignition switch: ON	MAIN switch: Pressed at the 1st time → at the 2nd time	ON → OFF
SET LAMP	• MAIN switch: ON • Vehicle speed: Between 40 km/h (25 MPH) and 144 km/h (89 MPH)	ASCD: Operating	ON
		ASCD: Not operating	OFF

*: Accelerator pedal position sensor 2 signal and throttle position sensor 2 signal are converted by ECM internally. Thus, they differ from ECM terminals voltage signal.

*: Before measuring the terminal voltage, confirm that the battery is fully charged. Refer to [PG-3, "How to Handle Battery"](#)

TERMINAL LAYOUT

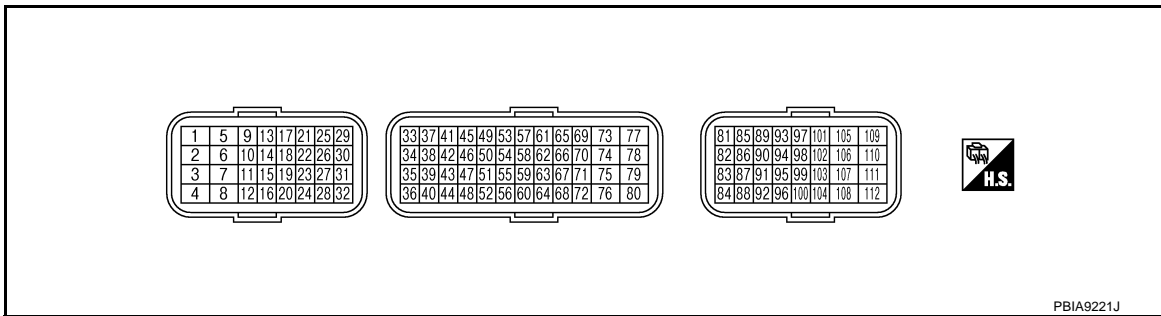

PHYSICAL VALUES

NOTE:

- ECM is located in the engine room left side near battery.
- Specification data are reference values and are measured between each terminal and ground.
- Pulse signal is measured by CONSULT-III.

< ECU DIAGNOSIS INFORMATION >

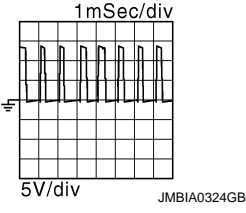
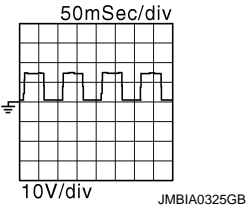
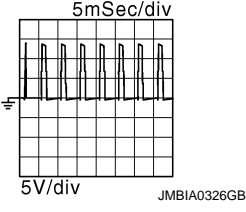
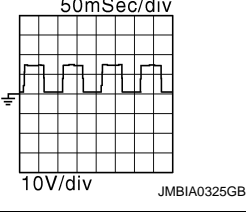
Terminal No.		Description		Condition	Value (Approx.)
+	-	Signal name	Input/ Output		
1 (P)	108 (B)	Throttle control motor (Open)	Output	[Ignition switch: ON] • Engine stopped • Shift lever: D (CVT), 1st (M/T) • Accelerator pedal: Fully depressed	3.2 V★ 
2 (SB)	108 (B)	Throttle control motor re- lay power supply	Input	[Ignition switch: ON]	BATTERY VOLTAGE (11 - 14 V)
3 (G)	53 (B)	A/F sensor 1 heater	Output	[Engine is running] • Warm-up condition • Engine speed: Idle speed (Mpre than 140 seconds after start- ing engine)	2.9 - 8.8 V★ 
4 (L)	108 (B)	Throttle control motor (Close)	Output	[Ignition switch: ON] • Engine stopped • Shift lever: D (CVT), 1st (M/T) • Accelerator pedal: Fully released	1.8 V★ 
5 (G)	59 (O)	Heated oxygen sensor 2 heater	Output	[Engine is running] • Engine speed: Below 3,600 rpm af- ter the following conditions are met - Engine: after warming up - Keeping the engine speed between 3,500 and 4,000 rpm for 1 minute and at idle for 1 minute under no load	10 V★ 
				[Ignition switch: ON] • Engine stopped [Engine is running] • Engine speed: Above 3,600 rpm	BATTERY VOLTAGE (11 - 14 V)

ECM

< ECU DIAGNOSIS INFORMATION >

[MR18DE]

Terminal No.		Description		Condition	Value (Approx.)
+	-	Signal name	Input/Output		
9 (P)	108 (B)	EVAP canister purge volume control solenoid valve	Output	[Engine is running] • Idle speed • Accelerator pedal: Not depressed even slightly, after engine starting	BATTERY VOLTAGE (11 - 14 V)★
				[Engine is running] • Engine speed: About 2,000 rpm (More than 100 seconds after starting engine.)	10 V★
10 (B) 11 (B)	—	ECM ground	—	—	—
15 (Y)	108 (B)	Throttle control motor relay	Output	[Ignition switch: OFF]	BATTERY VOLTAGE (11 - 14 V)
				[Ignition switch: ON]	0 - 1.0 V
17 (R)	108 (B)	Ignition signal No. 1	Output	[Engine is running] • Warm-up condition • Idle speed NOTE: The pulse cycle changes depending on rpm at idle	0 - 0.3 V★
18 (LG)		Ignition signal No. 2		[Engine is running] • Warm-up condition • Engine speed: 2,500 rpm	0.2 - 0.5 V★
21 (G)		Ignition signal No. 4			
22 (SB)		Ignition signal No. 3			
23 (GR)	108 (B)	Fuel pump relay	Output	[Ignition switch: ON] • For 1 second after turning ignition switch ON [Engine is running]	0 - 1.0 V

A
EC
C
D
E
F
G
H
I
J
K
L
M
N
O
P

ECM

< ECU DIAGNOSIS INFORMATION >

[MR18DE]

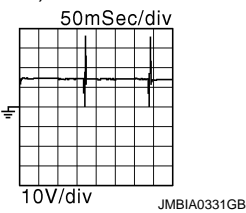
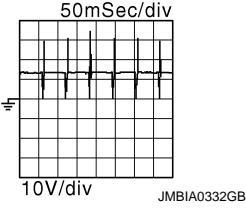
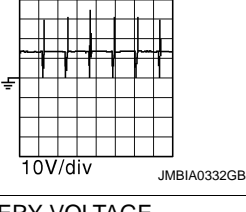
Terminal No.		Description		Condition	Value (Approx.)
+	-	Signal name	Input/Output		
25 (V)	108 (B)	Fuel injector No. 4	Output	[Engine is running] • Warm-up condition • Idle speed NOTE: The pulse cycle changes depending on rpm at idle	BATTERY VOLTAGE (11 - 14 V)★ 
29 (Y)		Fuel injector No. 3			BATTERY VOLTAGE (11 - 14 V)★ 
30 (O)		Fuel injector No. 2			BATTERY VOLTAGE (11 - 14 V)★ 
31 (L)		Fuel injector No. 1			[Engine is running] • Warm-up condition • Engine speed: 2,000 rpm
28 (W)	108 (B)	EVAP canister vent control valve	Output	[Ignition switch: ON]	BATTERY VOLTAGE (11 - 14 V)
32 (P)	108 (B)	ECM relay (Self shut-off)	Output	[Engine is running] [Ignition switch: OFF] • A few seconds after turning ignition switch OFF	0 - 1.0 V
				[Ignition switch: OFF] • More than a few seconds after turning ignition switch OFF	BATTERY VOLTAGE (11 - 14 V)
33 (LG)	36 (Y)	Throttle position sensor 1	Input	[Ignition switch: ON] • Engine stopped • Shift lever: D (CVT), 1st (M/T) • Accelerator pedal: Fully released	More than 0.36 V
				[Ignition switch: ON] • Engine stopped • Shift lever: D (CVT), 1st (M/T) • Accelerator pedal: Fully depressed	Less than 4.75 V
34 (V)	36 (Y)	Throttle position sensor 2	Input	[Ignition switch: ON] • Engine stopped • Shift lever: D (CVT), 1st (M/T) • Accelerator pedal: Fully released	Less than 4.75 V
				[Ignition switch: ON] • Engine stopped • Shift lever: D (CVT), 1st (M/T) • Accelerator pedal: Fully depressed	More than 0.36 V
36 (Y)	—	Sensor ground (Throttle position sensor)	—	—	—
37 (W)	40 (B)	Knock sensor	Input	[Engine is running] • Idle speed	2.5 V
38 (P)	44 (B)	Engine coolant temperature sensor	Input	[Engine is running]	0 - 4.8 V Output voltage varies with engine coolant temperature.
40 (B)	—	Sensor ground (Knock sensor)	—	—	—

ECM

< ECU DIAGNOSIS INFORMATION >

[MR18DE]

Terminal No.		Description		Condition	Value (Approx.)	
+	-	Signal name	Input/Output			
41 (GR)	48 (BR)	Refrigerant pressure sensor	Input	[Engine is running] • Warm-up condition • Both A/C switch and blower fan motor switch: ON (Compressor operates)	1.0 - 4.0 V	EC
42 (V)	51 (O)	EVAP control system pressure sensor	Input	[Ignition switch: ON]	1.8 - 4.8 V	C
43 (P)	108 (B)	Fuel tank temperature sensor	Input	[Engine is running]	0 - 4.8 V Output voltage varies with fuel tank temperature.	D
44 (B)	—	Sensor ground (Engine coolant temperature sensor)	—	—	—	E
45 (G)	52 (LG)	Mass air flow sensor	Input	[Engine is running] • Warm-up condition • Idle speed	0.7 - 1.1 V	F
				[Engine is running] • Warm-up condition • Engine speed : 2,500 rpm	1.3 - 1.7 V	G
46 (V)	55 (O)	Intake air temperature sensor	Input	[Engine is running]	0 - 4.8 V Output voltage varies with intake air temperature.	H
48 (BR)	—	Sensor ground (Refrigerant pressure sensor)	—	—	—	I
49 (W)	53 (B)	A/F sensor 1	Input	[Engine is running] • Warm-up condition • Engine speed: 2,000 rpm	Approximately 1.8 V Output voltage varies with air fuel ratio.	J
50 (W)	59 (O)	Heated oxygen sensor 2	Input	[Engine is running] • Revving engine from idle to 3,000 rpm quickly after the following conditions are met - Engine: after warming up - Keeping the engine speed between 3,500 and 4,000 rpm for 1 minute and at idle for 1 minute under no load	0 - 1.0 V	K
51 (O)	—	Sensor ground (EVAP control system pressure sensor)	—	—	—	L
52 (LG)	—	Sensor ground (Mass air flow sensor)	—	—	—	M
53 (B)	—	Sensor ground (A/F sensor 1)	—	—	—	N
55 (O)	—	Sensor ground (Intake air temperature sensor)	—	—	—	O
58 (GR)	68 (SB)	Battery current sensor	Input	[Engine is running] • Battery: Fully charged *1 • Idle speed	2.6 - 3.5 V	P
59 (O)	—	Sensor ground (Heated oxygen sensor 2)	—	—	—	

< ECU DIAGNOSIS INFORMATION >

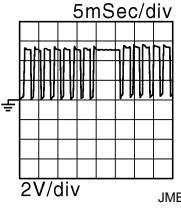
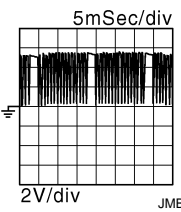
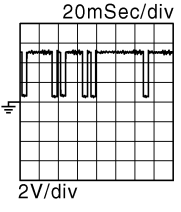
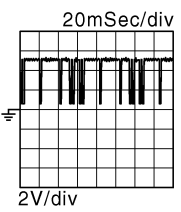
Terminal No.		Description		Condition	Value (Approx.)
+	-	Signal name	Input/Output		
61 (W)	62 (R)	Crankshaft position sensor (POS)	Input	[Engine is running] • Warm-up condition • Idle speed NOTE: The pulse cycle changes depending on rpm at idle	4.0 V★ 
				[Engine is running] • Engine speed: 2,000 rpm	4.0 V★ 
62 (R)	—	Sensor ground [Crankshaft position sensor (POS)]	—	—	—
63 (BR)	—	Sensor ground [Camshaft position sensor (PHASE)]	—	—	—
65 (G)	63 (BR)	Camshaft position sensor (PHASE)	Input	[Engine is running] • Warm-up condition • Idle speed NOTE: The pulse cycle changes depending on rpm at idle	0 - 5.0★ 
				[Engine is running] • Engine speed is 2,000 rpm	0 - 5.0★ 
68 (SB)	—	Sensor ground (Battery current sensor)	—	—	—
69 (L)	108 (B)	PNP switch	Input	[Ignition switch: ON] • Shift lever: P or N (CVT), Neutral (M/T)	BATTERY VOLTAGE (11 - 14 V)
				[Ignition switch: ON] • Shift lever: Except above	0 V
72 (O)	36 (Y)	Sensor power supply (Throttle position sensor)	—	[Ignition switch: ON]	5 V

ECM

< ECU DIAGNOSIS INFORMATION >

[MR18DE]

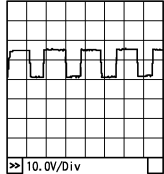
Terminal No.		Description		Condition	Value (Approx.)
+	-	Signal name	Input/Output		
73 (P)	108 (B)	Intake valve timing control solenoid valve	Output	[Engine is running] • Warm-up condition • Idle speed	BATTERY VOLTAGE (11 - 14 V)
				[Engine is running] • Warm-up condition • When revving engine up to 2,000rpm Quickly	7 - 10 V★ 
74 (W)	108 (B)	Sensor power supply (Refrigerant pressure sensor)	Input	[Ignition switch: ON]	5 V
75 (BR)	62 (R)	Sensor power supply [Crankshaft position sensor (POS)]	—	[Ignition switch: ON]	5 V
76 (W)	51 (O)	Sensor power supply [EVAP control system pressure sensor]	—	[Ignition switch: ON]	5 V
77 (Y)	108 (B)	Sensor power supply [Battery current sensor]	—	[Ignition switch: ON]	5 V
78 (O)	63 (BR)	Sensor power supply [Camshaft position sensor (PHASE)]	—	[Ignition switch: ON]	5 V
83 (L)	108 (B)	CAN communication line	Input/Output	—	—
84 (P)	108 (B)	CAN communication line	Input/Output	—	—
88 (LG)	108 (B)	Data link connector	Input/Output	—	—
93 (L)	108 (B)	Ignition switch	Input	[Ignition switch: OFF]	0 V
				[Ignition switch: ON]	BATTERY VOLTAGE (11 - 14 V)
94 (SB)	95 (BR)	ASCDC steering switch	Input	[Ignition switch: ON] • ASCDC steering switch: OFF	4 V
				[Ignition switch: ON] • MAIN switch: Pressed	0 V
				[Ignition switch: ON] • CANCEL switch: Pressed	1 V
				[Ignition switch: ON] • RESUME/ACCELERATE switch: Pressed	3 V
				[Ignition switch: ON] • SET/COAST switch: Pressed	2 V
95 (BR)	—	Sensor ground (ASCDC steering switch)	—	—	—
99 (W)	108 (B)	Stop lamp switch	Input	[Ignition switch: OFF] • Brake pedal: Fully released	0 V
				[Ignition switch: OFF] • Brake pedal: Slightly depressed	BATTERY VOLTAGE (11 - 14 V)

A
EC
C
D
E
F
G
H
I
J
K
L
M
N
O
P

ECM

< ECU DIAGNOSIS INFORMATION >

[MR18DE]

Terminal No.		Description		Condition	Value (Approx.)
+	-	Signal name	Input/Output		
100 (SB)	108 (B)	ASCDC brake switch	Input	[Ignition switch: ON] • Brake pedal: Slightly depressed (CVT) • Brake pedal and clutch pedal: Slightly depressed (M/T)	0 V
				[Ignition switch: ON] • Brake pedal: Fully released (CVT) • Brake pedal and/or clutch pedal: Fully released (M/T)	BATTERY VOLTAGE (11 - 14 V)
102 (O)	108 (B)	Sensor power supply (Accelerator pedal position sensor 2)	—	[Ignition switch: ON]	5 V
103 (G)	104 (R)	Accelerator pedal position sensor 2	Input	[Ignition switch: ON] • Engine stopped • Accelerator pedal: Fully released	0.3 - 0.6 V
				[Ignition switch: ON] • Engine stopped • Accelerator pedal: Fully depressed	1.95 - 2.4 V
104 (R)	—	Sensor ground (Accelerator pedal position sensor 2)	—	—	—
105 (G)	108 (B)	Power supply for ECM	Input	[Ignition switch: ON]	BATTERY VOLTAGE (11 - 14 V)
106 (V)	108 (B)	Sensor power supply (Accelerator pedal position sensor 1)	—	[Ignition switch: ON]	5 V
108 (B)	—	ECM ground	—	—	—
110 (BR)	111 (Y)	Accelerator pedal position sensor 1	Input	[Ignition switch: ON] • Engine stopped • Accelerator pedal: Fully released	0.6 - 0.9 V
				[Ignition switch: ON] • Engine stopped • Accelerator pedal: Fully depressed	3.9 - 4.7 V
111 (Y)	—	Sensor ground (Accelerator pedal position sensor 1)	—	—	—

★: Average voltage for pulse signal (Actual pulse signal can be confirmed by oscilloscope.)

*1: Before measuring the terminal voltage, confirm that the battery is fully charged. Refer to [PG-3, "How to Handle Battery"](#)

Wiring Diagram — ENGINE CONTROL SYSTEM —

INFOID:000000004833547

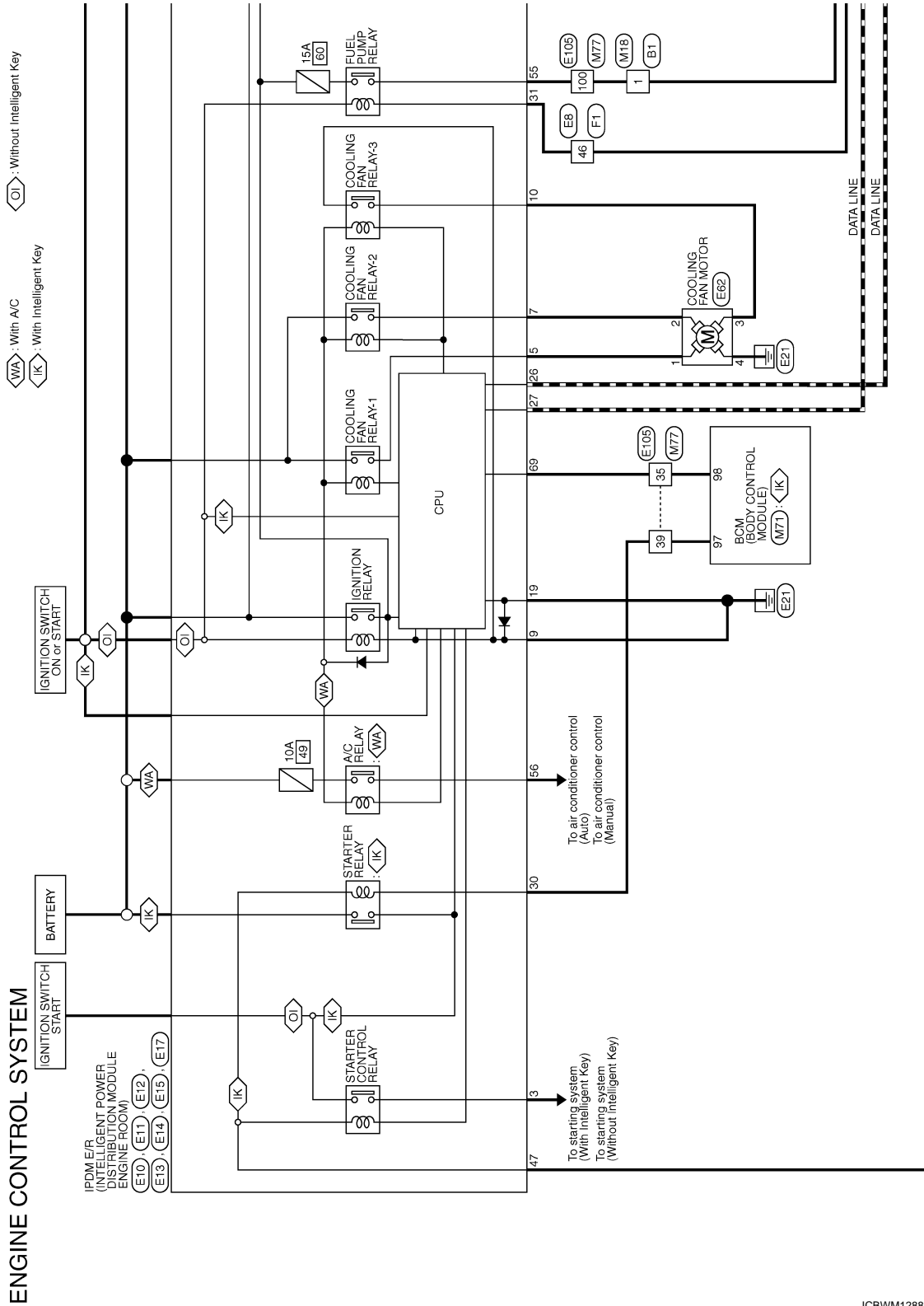

2009/02/27

JCBWM1288GB

A
EC
C
D
E
F
G
H
I
J
K
L
M
N
O
P

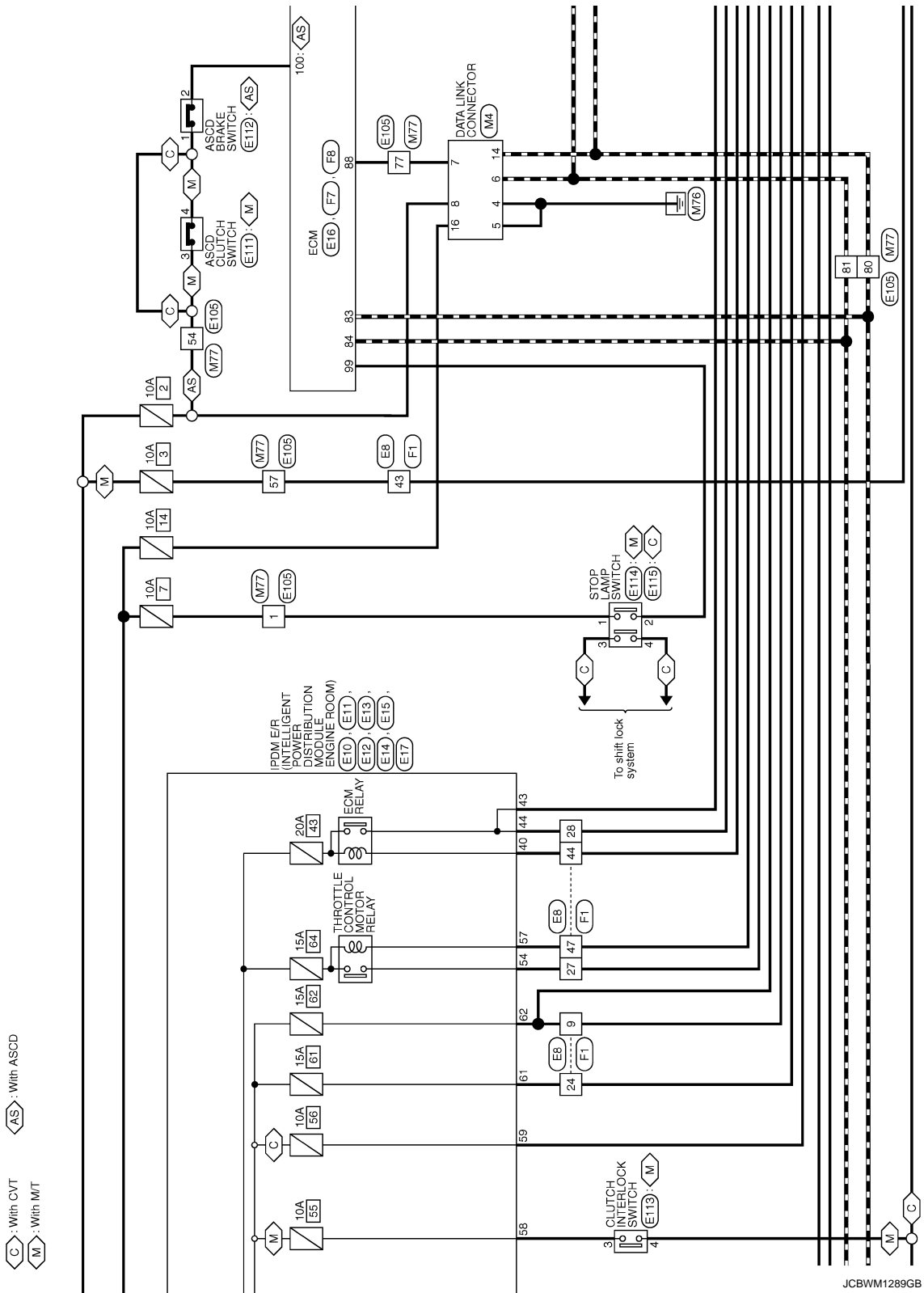

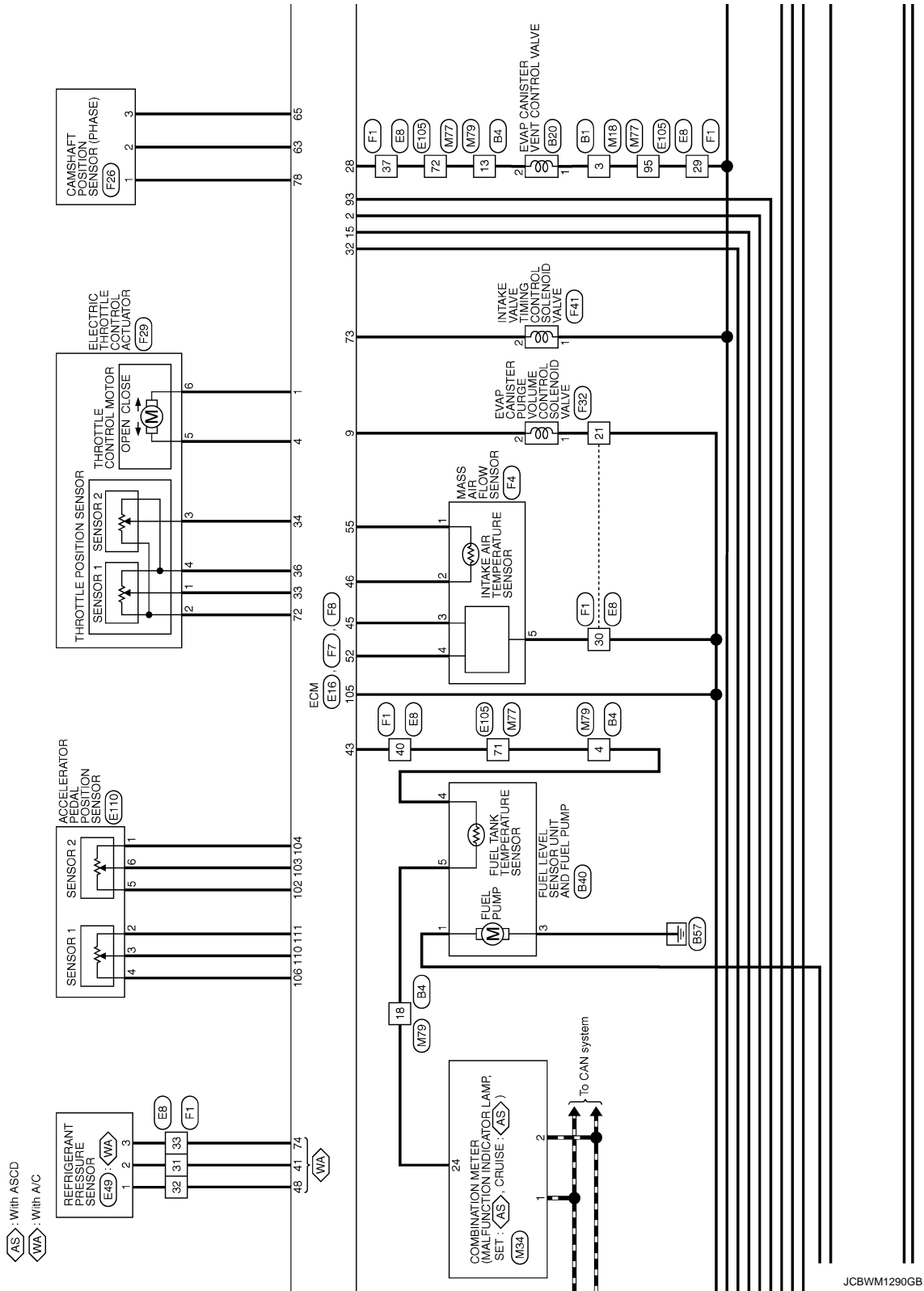

JCBWM1290GB

A
EC
C
D
E
F
G
H
I
J
K
L
M
N
O
P

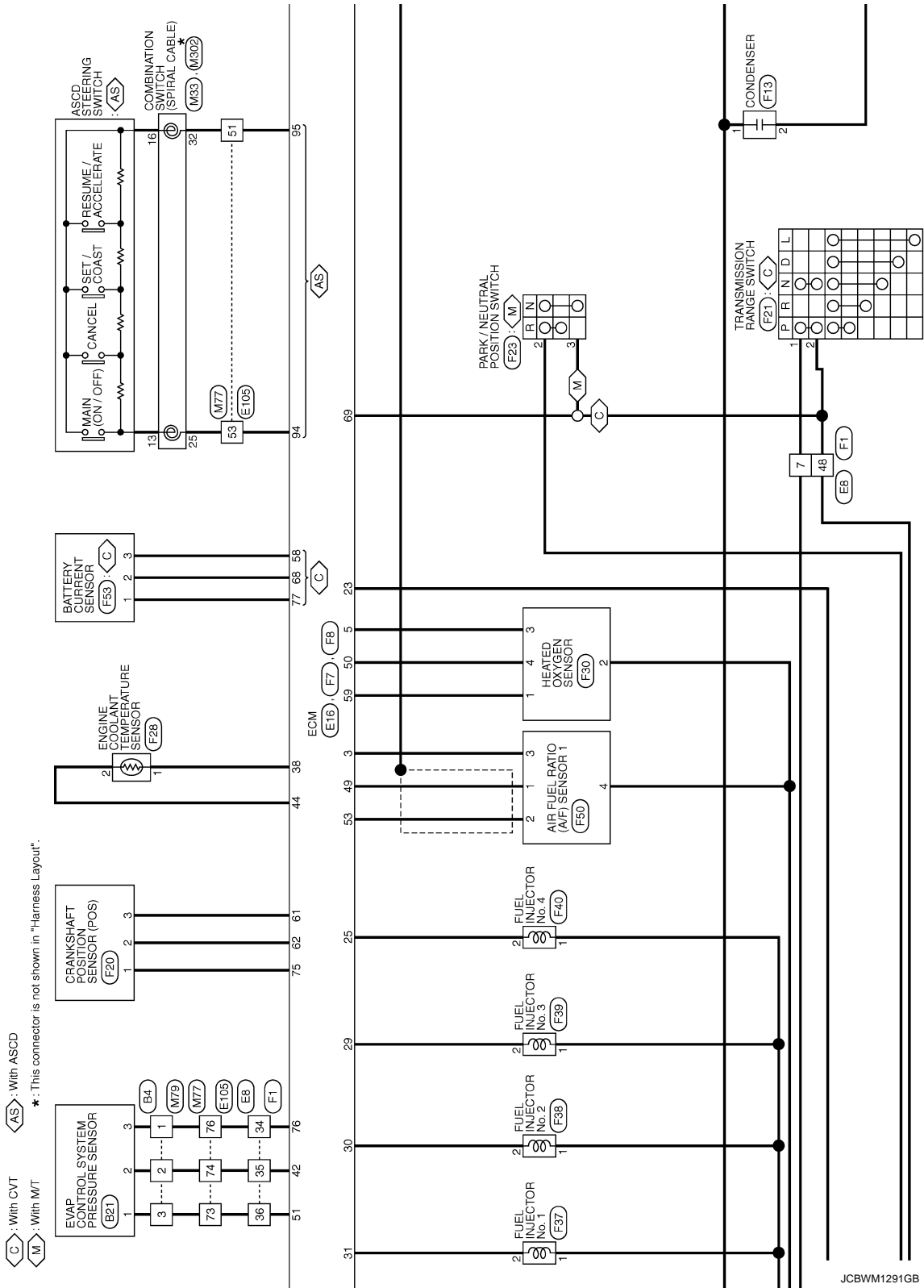

JCBWM1291GB

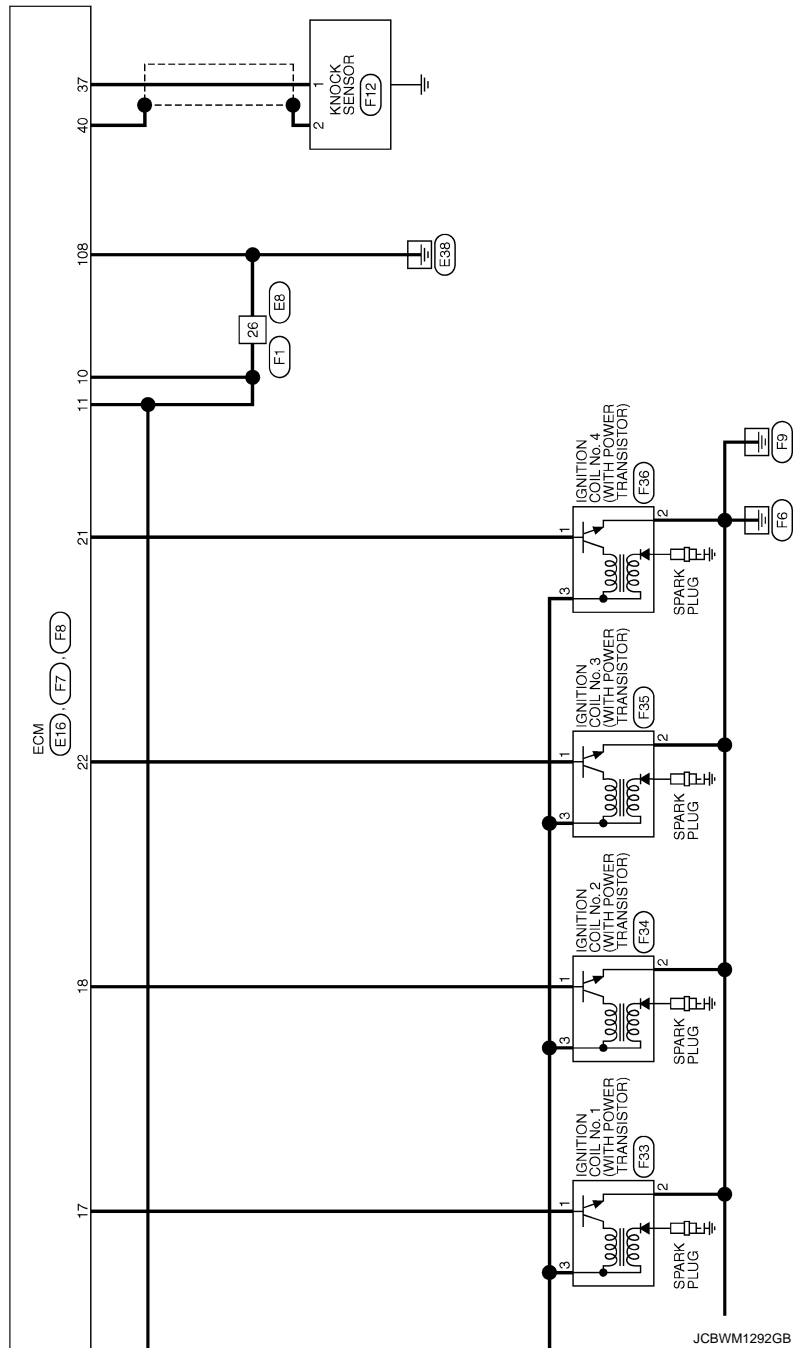

JCBWM1292GB

ENGINE CONTROL SYSTEM

Connector No.	B1
Connector Name	WIRE TO WIRE
Connector Type	HS16MW-CS

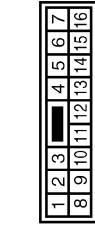

Terminal No.	Color of Wire	Signal Name [Specification]
1	G	-
3	V	-

Connector No.	B4
Connector Name	WIRE TO WIRE
Connector Type	TH24MPV-HH



Terminal No.	Color of Wire	Signal Name [Specification]
1	W	-
2	V	-
3	O	-
4	P	-
13	L	-
18	L	-

Connector No.	B20
Connector Name	EVAP CANISTER VENT CONTROL VALVE
Connector Type	E30TFS-RS



Terminal No.	Color of Wire	Signal Name [Specification]
1	V	-
2	L	-

Connector No.	B21
Connector Name	EVAP CONTROL SYSTEM PRESSURE SENSOR
Connector Type	EG8FGY-RS



Terminal No.	Color of Wire	Signal Name [Specification]
1	O	-
2	V	-
3	W	-

Connector No.	B40
Connector Name	FUEL LEVEL SENSOR UNIT AND FUEL PUMP
Connector Type	EG8FGY-RS

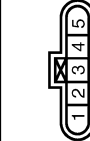

Terminal No.	Color of Wire	Signal Name [Specification]
1	G	-
3	B	-
4	P	-
5	L	-

Connector No.	E8
Connector Name	WIRE TO WIRE
Connector Type	SAA36MB-RS10-SJZZ

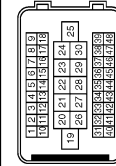

Terminal No.	Color of Wire	Signal Name [Specification]
7	Y	-
9	L	-
21	G	-
24	W	-
26	B	-
27	GR	-
28	P	-
29	V	-
30	G	-
31	G	-
32	O	-

Terminal No.	Color of Wire	Signal Name [Specification]
33	W	-
34	Y	-
35	V	-
36	P	-
37	LG	-
40	GR	-
43	LG	-
44	R	- [With M/T]
46	W	-
47	G	-
48	BR	-

Connector No.	E10
Connector Name	IPDM E/R (INTELLIGENT POWER DISTRIBUTION MODULE ENGINE ROOM)
Connector Type	MM6FW-LC

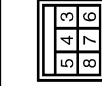

Terminal No.	Color of Wire	Signal Name [Specification]
3	BR	-
5	LG	-
7	Y	-

ENGINE CONTROL SYSTEM

Connector No.	E49
Connector Name	REFRIGERANT PRESSURE SENSOR
Connector Type	RK03FB



Terminal No.	Color of Wire	Signal Name [Specification]
1	O	-
2	G	-
3	W	-

Connector No.	E62
Connector Name	COOLING FAN MOTOR
Connector Type	RS04FY-PR



Terminal No.	Color of Wire	Signal Name [Specification]
1	LG	-
2	Y	-
3	L	-
4	B/W	-

Connector No.	E105
Connector Name	WIRE TO WIRE
Connector Type	T1H0MW-C518-TM4

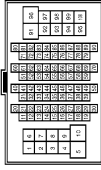

Terminal No.	Color of Wire	Signal Name [Specification]
1	V	-
35	Y	-
39	SB	- [With CVT]
51	BR	- [With M/T]
51	B	- [With M/T]
52	SB	- [With CVT]
54	W	- [With CVT]
54	O	- [With M/T]
57	LG	-
71	GR	-
72	LG	-

73	P	-
74	V	-
76	Y	-
77	LG	-
80	P	-
81	L	-
95	V	-
100	P	-

Connector No.	E10
Connector Name	ACCELERATOR PEDAL POSITION SENSOR
Connector Type	RH06FB

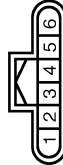

Terminal No.	Color of Wire	Signal Name [Specification]
1	R	-
2	Y	-
3	BR	-
4	V	-
5	O	-
6	G	-

Connector No.	E11
Connector Name	ASCD CLUTCH SWITCH
Connector Type	M04FW-LC



Terminal No.	Color of Wire	Signal Name [Specification]
3	O	-
4	R	-

Connector No.	E112
Connector Name	ASCD BRAKE SWITCH
Connector Type	M02FER-LC



Terminal No.	Color of Wire	Signal Name [Specification]
1	W	- [With CVT]
1	R	- [With M/T]
2	SB	-

Connector No.	E113
Connector Name	CLUTCH INTERLOCK SWITCH
Connector Type	M04FW-LC



Terminal No.	Color of Wire	Signal Name [Specification]
3	Y	-
4	BR	-

JCBWM1295GB

ENGINE CONTROL SYSTEM

Connector No.	E114
Connector Name	STOP LAMP SWITCH (WITH M/T)
Connector Type	MD2PB-LC



Terminal No.	Color of Wire	Signal Name [Specification]
1	V	-
2	W	-

Connector No.	E115
Connector Name	STOP LAMP SWITCH (WITH CVT)
Connector Type	MD4FW-LC



Terminal No.	Color of Wire	Signal Name [Specification]
1	V	-
2	W	-
3	O	-
4	G	-

Connector No.	F1
Connector Name	WIRE TO WIRE
Connector Type	SAA38FB-RS(IP-SJ72)

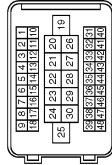

Terminal No.	Color of Wire	Signal Name [Specification]
7	V	-
9	SB	-
21	G	-
24	R	-
26	B	-
27	SB	-
28	V	-
30	BR	-
31	GR	-
32	BR	-

Connector No.	F4
Connector Name	MASS AIR FLOW SENSOR
Connector Type	RH08FB



Terminal No.	Color of Wire	Signal Name [Specification]
1	P	-
2	L	-
3	G	-
4	R	-
5	BR	-

Connector No.	F7
Connector Name	ECM
Connector Type	RH24FGY-RZ6-R-RH

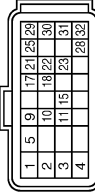

Terminal No.	Color of Wire	Signal Name [Specification]
1	P	MOTOR1
2	SB	VMOT
3	G	AF HEATER GND
4	L	MOTOR2
5	G	O2HR
9	P	EVAP
10	B	GND
11	B	GND
15	Y	MOTRLY
17	R	ING#1
18	LG	ING#2

21	G	ING#4
22	SB	ING#3
23	GR	FPR
25	V	INJ#4
28	W	CDCV
29	Y	INJ#3
30	O	INJ#2
31	L	INJ#1
32	P	SSOFF

33	W	-
34	LG	-
35	V	-
36	Y	-
37	W	-
40	P	-
43	R	-
44	P	-
46	GR	-
47	Y	-
48	BR	-

A
EC
C
D
E
F
G
H
I
J
K
L
M
N
O
P

ENGINE CONTROL SYSTEM

Connector No.	FB
Connector Name	ECM
Connector Type	RH40FB-R28-L-RH

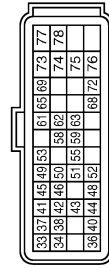

Terminal No.	Color of Wire	Signal Name [Specification]
33	LG	TPS1
34	R	TPSZ
36	Y	GND-TPS
37	W	KNK
38	BR	TW
40	SHIELD	GND-KNK
41	GR	PDPRES
42	V	FIPRES
43	P	TF
44	GR	GND-TW
45	G	GA+

Connector No.	F20
Connector Name	CRANKSHAFT POSITION SENSOR (POS)
Connector Type	RH03FB



Terminal No.	Color of Wire	Signal Name [Specification]
1	BR	-
2	R	-
3	W	-

46	L	TA
48	BR	GND-PDPRES
49	V	AF+
50	W	OZSR
51	Y	GND-FIPRES
52	R	GA-
53	LG	AF-
55	P	GND-TA
58	GR	CURSEN
59	O	GND-OZSR
61	W	POS
62	R	GND-POS
63	BR	GND-PHASE
65	G	PHASE
68	S5	GND-CURSEN
69	L	NEUT-H
72	O	AVCC-TPS
73	P	CVTC
74	W	AVCC-PDPRES
75	BR	AVCC-POS
76	LG	AVCC-FIPRES
77	Y	AVCC-CURSEN
78	O	AVCC-PHASE

Connector No.	F21
Connector Name	TRANSMISSION RANGE SWITCH
Connector Type	RK08FG



Terminal No.	Color of Wire	Signal Name [Specification]
1	R	-
2	W	-

Connector No.	F12
Connector Name	KNOCK SENSOR
Connector Type	BS02FB-AY



Terminal No.	Color of Wire	Signal Name [Specification]
1	W	-
2	SHIELD	-

Connector No.	F23
Connector Name	PARK / NEUTRAL POSITION SWITCH
Connector Type	FEA03FG



Terminal No.	Color of Wire	Signal Name [Specification]
1	R	-
2	L	-
3	L	-

Connector No.	F13
Connector Name	CONDENSER
Connector Type	MM02FW-LC



Terminal No.	Color of Wire	Signal Name [Specification]
1	V	-
2	B	-

Connector No.	F26
Connector Name	CAMSHAFT POSITION SENSOR (PHASE)
Connector Type	RH03FB



Terminal No.	Color of Wire	Signal Name [Specification]
1	O	-
2	BR	-
3	G	-

ENGINE CONTROL SYSTEM

Connector No. F28	ENGINE COOLANT TEMPERATURE SENSOR	Connector No. F29	ELECTRIC THROTTLE CONTROL ACTUATOR	Connector No. F30	HEATED OXYGEN SENSOR	Connector No. F36	IGNITION COIL No. 1 (WITH POWER TRANSISTOR)	Connector No. F37	IGNITION COIL No. 2 (WITH POWER TRANSISTOR)	Connector No. F38	IGNITION COIL No. 3 (WITH POWER TRANSISTOR)	Connector No. F39	IGNITION COIL No. 4 (WITH POWER TRANSISTOR)
Connector Name E02FGY-RS		Connector Name H30GFB		Connector Name AFZ04FB-P		Connector Name E03FGY-RS		Connector Name E03FGY-RS		Connector Name E03FGY-RS		Connector Name E03FGY-RS	
Connector Type H.S.		Connector Type H.S.		Connector Type H.S.		Connector Type H.S.		Connector Type H.S.		Connector Type H.S.		Connector Type H.S.	
Terminal No. 1 2	Color of Wire BR GR	Terminal No. 1 2 3 4 5 6	Color of Wire LG O R Y L P	Terminal No. 1 2 3 4	Color of Wire O R G W	Terminal No. 1 2 3	Color of Wire G P	Terminal No. 1 2 3	Color of Wire SB B V	Terminal No. 1 2 3	Color of Wire G B V	Terminal No. 1 2 3	Color of Wire G B V
	Signal Name [Specification]		Signal Name [Specification]		Signal Name [Specification]		Signal Name [Specification]		Signal Name [Specification]		Signal Name [Specification]		Signal Name [Specification]

JCBWM1298GB

ENGINE CONTROL SYSTEM

Connector No. F37	FUEL INJECTOR No. 1	HS	1 2	Terminal No. 1	Color of Wire SB	Signal Name [Specification]	Terminal No. 1	Color of Wire SB	Signal Name [Specification]
Connector Name	FUEL INJECTOR No. 1			2	L	-	2	V	-
Connector Type	HS2ZFGY								
Connector No. F38	FUEL INJECTOR No. 2	HS	1 2	Terminal No. 1	Color of Wire SB	Signal Name [Specification]	Terminal No. 1	Color of Wire SB	Signal Name [Specification]
Connector Name	FUEL INJECTOR No. 2			2	O	-	2	Y	-
Connector Type	HS2ZFGY								
Connector No. F39	FUEL INJECTOR No. 3	HS	1 2	Terminal No. 1	Color of Wire SB	Signal Name [Specification]	Terminal No. 1	Color of Wire SB	Signal Name [Specification]
Connector Name	FUEL INJECTOR No. 3			2	Y	-	2	V	-
Connector Type	HS2ZFGY								
Connector No. F40	FUEL INJECTOR No. 4	HS	1 2	Terminal No. 1	Color of Wire SB	Signal Name [Specification]	Terminal No. 1	Color of Wire SB	Signal Name [Specification]
Connector Name	FUEL INJECTOR No. 4			2	V	-	2	V	-
Connector Type	HS2ZFGY								
Connector No. F41	INTAKE VALVE TIMING CONTROL SOLENOID VALVE	HS	2 1	Terminal No. 1	Color of Wire V	Signal Name [Specification]	Terminal No. 1	Color of Wire B	Signal Name [Specification]
Connector Name	INTAKE VALVE TIMING CONTROL SOLENOID VALVE			2	P	-	2	B	-
Connector Type	EDZFG-RS-LGY						5	B	-
Connector No. F50	AIR FUEL RATIO (A/F) SENSOR 1	HS	1 2 3 4	Terminal No. 1	Color of Wire V	Signal Name [Specification]	Terminal No. 1	Color of Wire Y	Signal Name [Specification]
Connector Name	AIR FUEL RATIO (A/F) SENSOR 1			2	LG	-	2	SB	-
Connector Type	AFZQAFGY-P			3	G	-	3	GR	-
Connector No. F53	BATTERY CURRENT SENSOR	HS	1 2 3	Terminal No. 1	Color of Wire Y	Signal Name [Specification]	Terminal No. 1	Color of Wire Y	Signal Name [Specification]
Connector Name	BATTERY CURRENT SENSOR			2	SB	-	2	SB	-
Connector Type	RH03FB			3	GR	-	3	GR	-
Connector No. M4	DATA LINK CONNECTOR	HS	1 4 16 4 5 6 7 8	Terminal No. 4	Color of Wire B	Signal Name [Specification]	Terminal No. 4	Color of Wire B	Signal Name [Specification]
Connector Name	DATA LINK CONNECTOR			5	B	-	5	B	-
Connector Type	BD16FW			6	L	-	6	L	-
				7	GR/R	-	7	GR/R	-
				8	O	-	8	O	-
				14	P	-	14	P	-
				16	LG/R	-	16	LG/R	-

JCBWM1299GB

ENGINE CONTROL SYSTEM

Connector No.	M18
Connector Name	WIRE TO WIRE
Connector Type	NS16FW-CS

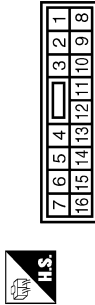

Terminal No.	Color of Wire	Signal Name [Specification]
1	G/R	-
3	L/W	-

Connector No.	M33
Connector Name	COMBINATION SWITCH (SPIRAL CABLE)
Connector Type	TK08FGY-1V

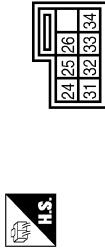

Terminal No.	Color of Wire	Signal Name [Specification]
25	R/L	-
32	B/W	-

Connector No.	M34
Connector Name	COMBINATION METER
Connector Type	TH40FW-NH

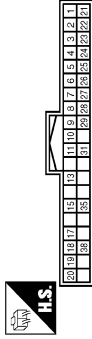

Terminal No.	Color of Wire	Signal Name [Specification]
1	L	CAN-H
2	P	CAN-L
24	V	FUEL LEVEL SENSOR GROUND

Connector No.	M71
Connector Name	ECM (BODY CONTROL MODULE) (WITH INTELLIGENT KEY)
Connector Type	TH40FW-NH

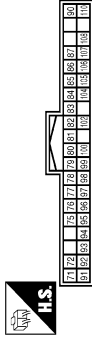

Terminal No.	Color of Wire	Signal Name [Specification]
97	L/R	STARTER RELAY CONT
98	BR	IGN RELAY (IPDM E/R) CONT

Connector No.	M77
Connector Name	WIRE TO WIRE
Connector Type	TH80FW-CS16-TM4

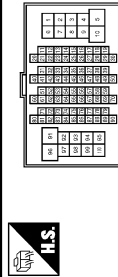

Terminal No.	Color of Wire	Signal Name [Specification]
1	B/O	-
35	BR	-
38	L/R	-
51	B/W	-
53	R/L	-
54	O	-
57	GR	-
71	P/B	-
72	R/G	-
73	R	-
74	L/Y	-

Terminal No.	76	W/G	-
77	GR/R	-	-
80	P	-	-
81	L	-	-
95	L/W	-	-
100	G/R	-	-

Connector No.	M79
Connector Name	WIRE TO WIRE
Connector Type	TH24FW-NH

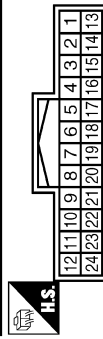

Terminal No.	Color of Wire	Signal Name [Specification]
1	W/G	-
2	L/Y	-
3	R	-
4	P/B	-
13	R/G	-
18	V	-

Connector No.	M302
Connector Name	COMBINATION SWITCH (SPIRAL CABLE)
Connector Type	TK08FGY



Terminal No.	Color of Wire	Signal Name [Specification]
13	R	-
18	B	-

A
EC
C
D
E
F
G
H
I
J
K
L
M
N
O
P

STARTING SYSTEM (WITH INTELLIGENT KEY)

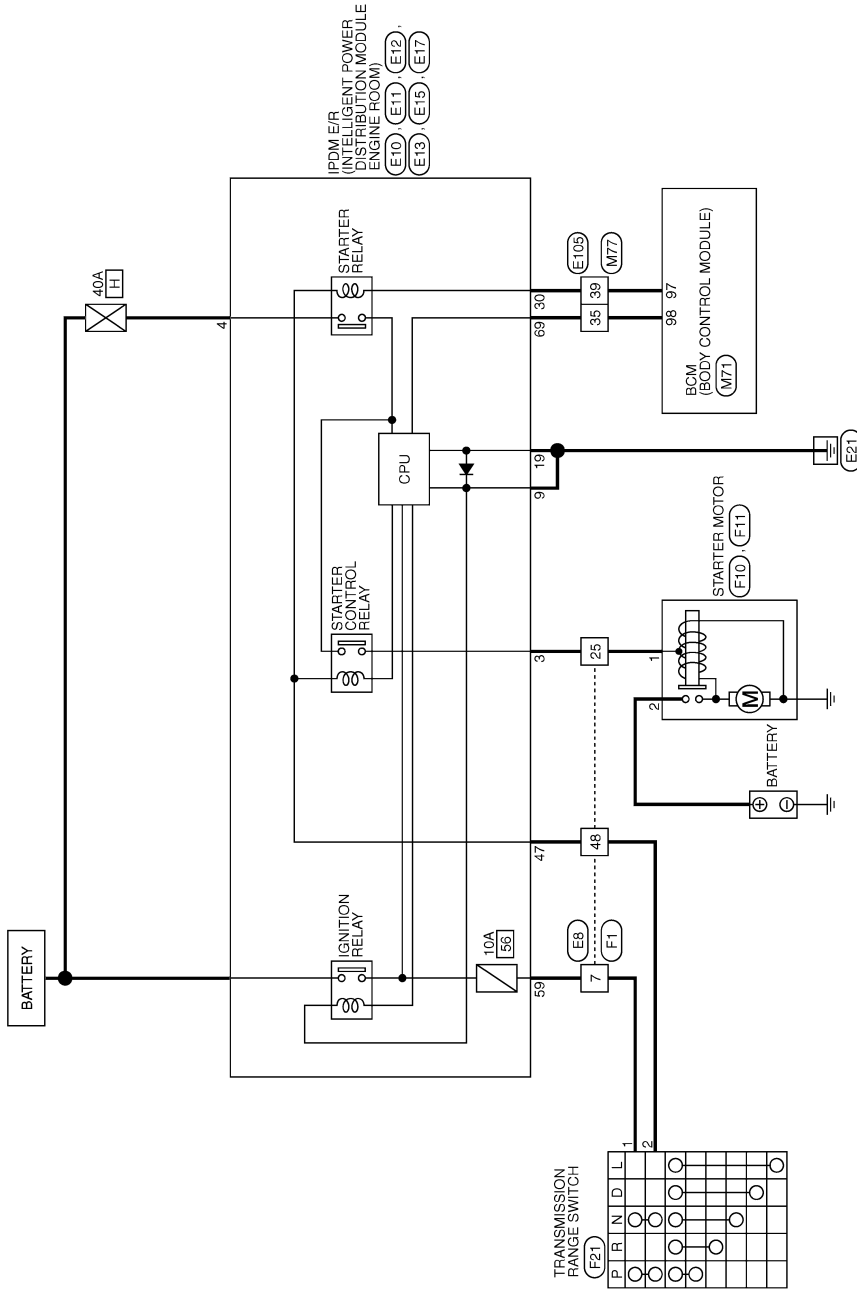

2009/02/27

JCBWM1301GB

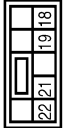

STARTING SYSTEM (WITH INTELLIGENT KEY)

Connector No.	E12
Connector Name	IPDM E/R (INTELLIGENT POWER DISTRIBUTION MODULE ENGINE ROOM)
Connector Type	NS33FBR-CS



Terminal No.	19	Color of Wire	B/W	Signal Name [Specification]

Connector No.	E11
Connector Name	IPDM E/R (INTELLIGENT POWER DISTRIBUTION MODULE ENGINE ROOM)
Connector Type	MD8FV-LC

Terminal No.	9	Color of Wire	B/W	Signal Name [Specification]

Connector No.	E10
Connector Name	IPDM E/R (INTELLIGENT POWER DISTRIBUTION MODULE ENGINE ROOM)
Connector Type	MD8FV-LC

Terminal No.	3	Color of Wire	BR	Signal Name [Specification]
	4		P	

Connector No.	EB
Connector Name	WIRE TO WIRE
Connector Type	SAA33MB-FS (S-SJZZ)

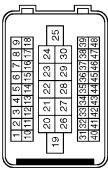

Terminal No.	7	Color of Wire	Y	Signal Name [Specification]
	25		BR	
	48		BR	

Connector No.	E105
Connector Name	WIRE TO WIRE
Connector Type	TH80MY-CS16-TM4

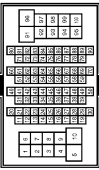

Terminal No.	35	Color of Wire	Y	Signal Name [Specification]
	39		SB	

Connector No.	E17
Connector Name	IPDM E/R (INTELLIGENT POWER DISTRIBUTION MODULE ENGINE ROOM)
Connector Type	TH10FB-NH



Terminal No.	69	Color of Wire	O	Signal Name [Specification]
--------------	----	---------------	---	-----------------------------

Connector No.	E15
Connector Name	IPDM E/R (INTELLIGENT POWER DISTRIBUTION MODULE ENGINE ROOM)
Connector Type	NS10FW-CS

Terminal No.	47	Color of Wire	BR	Signal Name [Specification]
	59		Y	

Connector No.	E13
Connector Name	IPDM E/R (INTELLIGENT POWER DISTRIBUTION MODULE ENGINE ROOM)
Connector Type	TH12FW-NH





Terminal No.	30	Color of Wire	SB	Signal Name [Specification]
--------------	----	---------------	----	-----------------------------

A
EC
C
D
E
F
G
H
I
J
K
L
M
N
O
P

STARTING SYSTEM (WITH INTELLIGENT KEY)

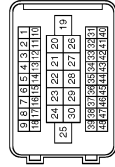
Connector No.	F1
Connector Name	WIRE TO WIRE
Connector Type	SA38FE-RS10-SLZZ



Terminal No.	Color of Wire	Signal Name [Specification]
7	V	
25	R	
48	BR	

Connector No.	F10
Connector Name	STARTER MOTOR
Connector Type	



Terminal No.	Color of Wire	Signal Name [Specification]
1	R	

Connector No.	F11
Connector Name	STARTER MOTOR
Connector Type	



Terminal No.	Color of Wire	Signal Name [Specification]
2	B/R	

Connector No.	FZ1
Connector Name	TRANSMISSION RANGE SWITCH
Connector Type	FR08FG



Terminal No.	Color of Wire	Signal Name [Specification]
1	R	
2	W	

Connector No.	M71
Connector Name	BCM (BODY CONTROL MODULE) (WITH INTELLIGENT KEY)
Connector Type	TH40FV-NH

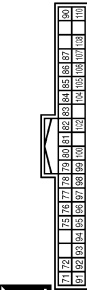

Terminal No.	Color of Wire	Signal Name [Specification]
97	L/R	STARTER RELAY COUNT
98	BR	IGN RELAY (IPDM E/R) COUNT

Connector No.	M77
Connector Name	WIRE TO WIRE
Connector Type	TH80FW-CS16-TM4



Terminal No.	Color of Wire	Signal Name [Specification]
35	BR	
39	L/R	

JCBWM1303GB

STARTING SYSTEM (WITHOUT INTELLIGENT KEY)

C: With CVT
M: With MTT

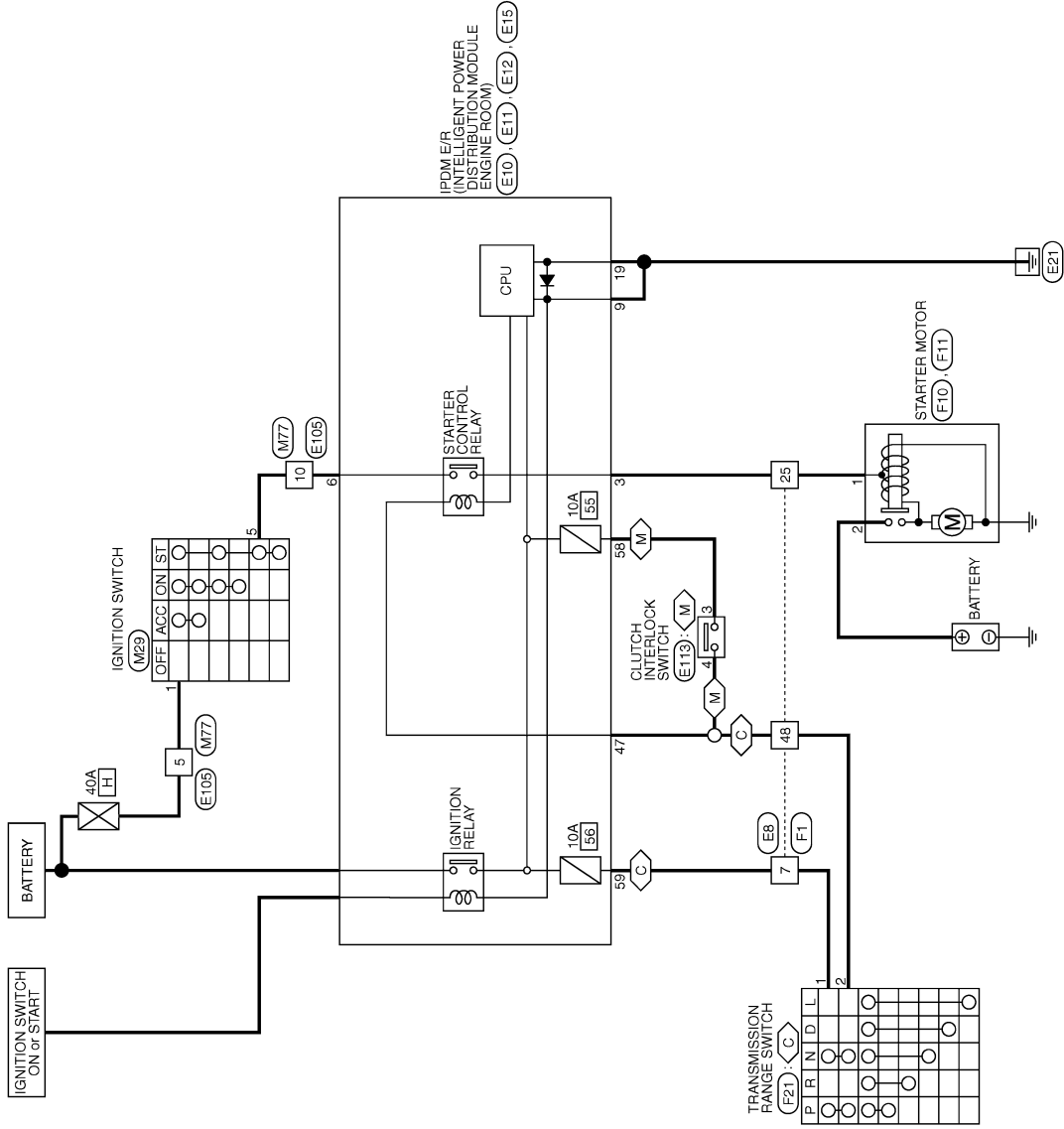

2009/02/27

JCBWM1304GB

A
EC
C
D
E
F
G
H
I
J
K
L
M
N
O
P

STARTING SYSTEM (WITHOUT INTELLIGENT KEY)

Connector No.	E12
Connector Name	IPDM E/R (INTELLIGENT POWER DISTRIBUTION MODULE ENGINE ROOM)
Connector Type	NS308FB-RS-CS

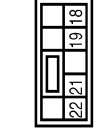

Terminal No.	19	Color of Wire	B/W	Signal Name [Specification]
--------------	----	---------------	-----	-----------------------------

Connector No.	E11
Connector Name	IPDM E/R (INTELLIGENT POWER DISTRIBUTION MODULE ENGINE ROOM)
Connector Type	M08FB-LC



Terminal No.	9	Color of Wire	B/W	Signal Name [Specification]
--------------	---	---------------	-----	-----------------------------

Connector No.	E10
Connector Name	IPDM E/R (INTELLIGENT POWER DISTRIBUTION MODULE ENGINE ROOM)
Connector Type	M08FV-LC



Terminal No.	3	Color of Wire	BR	Signal Name [Specification]
Terminal No.	6	Color of Wire	SB	Signal Name [Specification]

Connector No.	E8
Connector Name	WIRE TO WIRE
Connector Type	SAA38MB-RS10-SJZZ

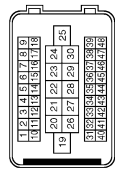

Terminal No.	7	Color of Wire	Y	Signal Name [Specification]
Terminal No.	25	Color of Wire	BR	Signal Name [Specification]
Terminal No.	48	Color of Wire	BR	Signal Name [Specification]

Connector No.	F1
Connector Name	WIRE TO WIRE
Connector Type	SAA38FB-RS10-SJZZ

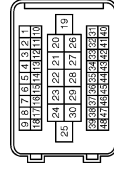

Terminal No.	7	Color of Wire	V	Signal Name [Specification]
Terminal No.	25	Color of Wire	R	Signal Name [Specification]
Terminal No.	48	Color of Wire	BR	Signal Name [Specification]

Connector No.	E113
Connector Name	CLUTCH INTERLOCK SWITCH
Connector Type	M04FV-LC



Terminal No.	3	Color of Wire	Y	Signal Name [Specification]
Terminal No.	4	Color of Wire	BR	Signal Name [Specification]

Connector No.	E105
Connector Name	WIRE TO WIRE
Connector Type	TH80MW-CS16-TM4



Terminal No.	5	Color of Wire	P	Signal Name [Specification]
Terminal No.	10	Color of Wire	SB	Signal Name [Specification]

Connector No.	E15
Connector Name	IPDM E/R (INTELLIGENT POWER DISTRIBUTION MODULE ENGINE ROOM)
Connector Type	NS16FV-CS

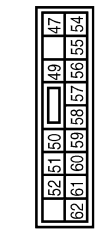

Terminal No.	47	Color of Wire	BR	Signal Name [Specification]
Terminal No.	58	Color of Wire	Y	Signal Name [Specification]
Terminal No.	59	Color of Wire	Y	Signal Name [Specification]

JCBWM1305GB

STARTING SYSTEM (WITHOUT INTELLIGENT KEY)

Connector No.	F10
Connector Name	STARTER MOTOR
Connector Type	-



Terminal No.	1	Color of Wire	R	Signal Name [Specification]	-
--------------	---	---------------	---	-----------------------------	---

Connector No.	F11
Connector Name	STARTER MOTOR
Connector Type	-



Terminal No.	2	Color of Wire	B/R	Signal Name [Specification]	-
--------------	---	---------------	-----	-----------------------------	---

Connector No.	F21
Connector Name	TRANSMISSION RANGE SWITCH
Connector Type	FKGBFG



Terminal No.	1	Color of Wire	R	Signal Name [Specification]	-
Terminal No.	2	Color of Wire	W	Signal Name [Specification]	-

Connector No.	M29
Connector Name	IGNITION SWITCH
Connector Type	MBBFV-LC



Terminal No.	1	Color of Wire	L	Signal Name [Specification]	-
Terminal No.	5	Color of Wire	W	Signal Name [Specification]	-

Connector No.	M77
Connector Name	WIRE TO WIRE
Connector Type	TH80FW-CS16-TM4

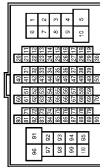

Terminal No.	5	Color of Wire	L	Signal Name [Specification]	-
Terminal No.	10	Color of Wire	W	Signal Name [Specification]	-

Fail Safe

NON DTC RELATED ITEM

JCBWM1306GB

INFOID:000000004833548

A
EC
C
D
E
F
G
H
I
J
K
L
M
N
O
P

ECM

< ECU DIAGNOSIS INFORMATION >

[MR18DE]

Detected items	Engine operating condition in fail-safe mode	Remarks
Malfunction indicator lamp circuit	Engine speed will not rise more than 2,500 rpm due to the fuel cut	When there is an open circuit on MIL circuit, the ECM cannot warn the driver by lighting up MIL when there is malfunction on engine control system. Therefore, when electrical controlled throttle and part of ECM related diagnoses are continuously detected as NG for 5 trips, ECM warns the driver that engine control system malfunctions and MIL circuit is open by means of operating fail-safe function. The fail-safe function also operates when above diagnoses except MIL circuit are detected and demands the driver to repair the malfunction.

DTC RELATED ITEM

DTC No.	Detected items	Engine operating condition in fail-safe mode								
P0011	Intake valve timing control	The signal is not energized to the intake valve timing control solenoid valve and the valve control does not function.								
P0102 P0103	Mass air flow sensor circuit	Engine speed will not rise more than 2,400 rpm due to the fuel cut.								
P0117 P0118	Engine coolant temperature sensor circuit	Engine coolant temperature will be determined by ECM based on the following condition. CONSULT-III displays the engine coolant temperature decided by ECM. <table border="1" style="width: 100%; margin-top: 5px;"> <thead> <tr> <th style="text-align: center;">Condition</th> <th style="text-align: center;">Engine coolant temperature decided (CONSULT-III display)</th> </tr> </thead> <tbody> <tr> <td>Just as ignition switch is turned ON or START</td> <td style="text-align: center;">40°C (104°F)</td> </tr> <tr> <td>More than approx. 4 minutes after engine starting</td> <td style="text-align: center;">80°C (176°F)</td> </tr> <tr> <td>Except as shown above</td> <td style="text-align: center;">40 - 80°C (104 - 176°F) (Depends on the time)</td> </tr> </tbody> </table> <p>When the fail-safe system for engine coolant temperature sensor is activated, the cooling fan operates while engine is running.</p>	Condition	Engine coolant temperature decided (CONSULT-III display)	Just as ignition switch is turned ON or START	40°C (104°F)	More than approx. 4 minutes after engine starting	80°C (176°F)	Except as shown above	40 - 80°C (104 - 176°F) (Depends on the time)
Condition	Engine coolant temperature decided (CONSULT-III display)									
Just as ignition switch is turned ON or START	40°C (104°F)									
More than approx. 4 minutes after engine starting	80°C (176°F)									
Except as shown above	40 - 80°C (104 - 176°F) (Depends on the time)									
P0122 P0123 P0222 P0223 P2135	Throttle position sensor	The ECM controls the electric throttle control actuator in regulating the throttle opening in order for the idle position to be within +10 degrees. The ECM regulates the opening speed of the throttle valve to be slower than the normal condition. So, the acceleration will be poor.								
P0643	Sensor power supply	ECM stops the electric throttle control actuator control, throttle valve is maintained at a fixed opening (approx. 5 degrees) by the return spring.								
P0605	ECM	(When ECM calculation function is malfunctioning:) ECM stops the electric throttle control actuator control, throttle valve is maintained at a fixed opening (approx. 5 degrees) by the return spring.								
P1805	Brake switch	ECM controls the electric throttle control actuator by regulating the throttle opening to a small range. Therefore, acceleration will be poor. <table border="1" style="width: 100%; margin-top: 5px;"> <thead> <tr> <th style="text-align: center;">Vehicle condition</th> <th style="text-align: center;">Driving condition</th> </tr> </thead> <tbody> <tr> <td>When engine is idling</td> <td style="text-align: center;">Normal</td> </tr> <tr> <td>When accelerating</td> <td style="text-align: center;">Poor acceleration</td> </tr> </tbody> </table>	Vehicle condition	Driving condition	When engine is idling	Normal	When accelerating	Poor acceleration		
Vehicle condition	Driving condition									
When engine is idling	Normal									
When accelerating	Poor acceleration									
P2100 P2103	Throttle control motor relay	ECM stops the electric throttle control actuator control, throttle valve is maintained at a fixed opening (approx. 5 degrees) by the return spring.								
P2101	Electric throttle control function	ECM stops the electric throttle control actuator control, throttle valve is maintained at a fixed opening (approx. 5 degrees) by the return spring.								
P2118	Throttle control motor	ECM stops the electric throttle control actuator control, throttle valve is maintained at a fixed opening (approx. 5 degrees) by the return spring.								

ECM

< ECU DIAGNOSIS INFORMATION >

[MR18DE]

DTC No.	Detected items	Engine operating condition in fail-safe mode
P2119	Electric throttle control actuator	(When electric throttle control actuator does not function properly due to the return spring malfunction:) ECM controls the electric throttle actuator by regulating the throttle opening around the idle position. The engine speed will not rise more than 2,000 rpm.
		(When throttle valve opening angle in fail-safe mode is not in specified range:) ECM controls the electric throttle control actuator by regulating the throttle opening to 20 degrees or less.
		(When ECM detects the throttle valve is stuck open:) While the vehicle is driving, it slows down gradually by fuel cut. After the vehicle stops, the engine stalls. The engine can restart in N or P (CVT), Neutral (M/T) position, and engine speed will not exceed 1,000 rpm or more.
P2122 P2123 P2127 P2128 P2138	Accelerator pedal position sensor	The ECM controls the electric throttle control actuator in regulating the throttle opening in order for the idle position to be within +10 degrees. The ECM regulates the opening speed of the throttle valve to be slower than the normal condition. So, the acceleration will be poor.

DTC Inspection Priority Chart

INFOID:000000005040139

If some DTCs are displayed at the same time, perform inspections one by one based on the following priority chart.

Priority	Detected items (DTC)
1	<ul style="list-style-type: none"> • U0101 U0140 U1001 CAN communication line • P0101 P0102 P0103 Mass air flow sensor • P0112 P0113 P0127 Intake air temperature sensor • P0116 P0117 P0118 P0125 Engine coolant temperature sensor • P0122 P0123 P0222 P0223 P1225 P1226 P2135 Throttle position sensor • P0128 Thermostat function • P0181 P0182 P0183 Fuel tank temperature sensor • P0327 P0328 Knock sensor • P0335 Crankshaft position sensor (POS) • P0340 Camshaft position sensor (PHASE) • P0460 P0461 P0462 P0463 Fuel level sensor • P0500 Vehicle speed sensor • P0605 P607 ECM • P0643 Sensor power supply • P0705 P0850 Park/neutral position (PNP) switch • P1550 P1551P1552 P1553 P1554 Battery current sensor • P1610 - P1615 NATS • P2122 P2123 P2127 P2128 P2138 Accelerator pedal position sensor

Priority	Detected items (DTC)
2	<ul style="list-style-type: none"> • P0031 P0032 Air fuel ratio (A/F) sensor 1 heater • P0037 P0038 Heated oxygen sensor 2 heater • P0075 Intake valve timing control solenoid valve • P0130 P0131 P0132 P0133 P2A00 Air fuel ratio (A/F) sensor 1 • P0137 P0138 P0139 Heated oxygen sensor 2 • P0441 EVAP control system purge flow monitoring • P0443 P0444 P0445 EVAP canister purge volume control solenoid valve • P0447 P0448 EVAP canister vent control valve • P0451 P0452 P0453 EVAP control system pressure sensor • P0710 P0715 P0720 P0740 P0744 P0745 P0746 P0776 P0778 P0840 P1740 P1777 P1778 CVT related sensors, solenoid valves and switches • P1217 Engine over temperature (OVERHEAT) • P1805 Brake switch • P2100 P2103 Throttle control motor relay • P2101 Electric throttle control function • P2118 Throttle control motor
3	<ul style="list-style-type: none"> • P0011 Intake valve timing control • P0171 P0172 Fuel injection system function • P0300 - P0304 Misfire • P0420 Three way catalyst function • P0442 P0456 EVAP control system (SMALL LEAK, VERY SMALL LEAK) • P0455 EVAP control system (GROSS LEAK) • P0506 P0507 Idle speed control system • P1148 Closed loop control • P1212 TCS communication line • P1421 Cold start control • P1564 ASCD steering switch • P1572 ASCD brake switch • P1574 ASCD vehicle speed sensor • P1715 Input speed sensor • P2119 Electric throttle control actuator

DTC Index

INFOID:000000005040140

×:Applicable —: Not applicable

DTC*1		Items (CONSULT-III screen terms)	SRT code	Trip	MIL	Reference page
CONSULT-III GST*2	ECM*3					
U0101	0101*4	LOST COMM (TCM)	—	1	×	EC-120
U0140	0140*4	LOST COMM (BCM)	—	1	×	EC-121
U1001	1001*4	CAN COMM CIRCUIT	—	2	—	EC-122
P0000	0000	NO DTC IS DETECTED. FURTHER TESTING MAY BE REQUIRED.	—	—	Flashing*7	—
P0011	0011	INT/V TIM CONT-B1	×	2	×	EC-123
P0031	0031	A/F SEN1 HTR (B1)	—	2	×	EC-127
P0032	0032	A/F SEN1 HTR (B1)	—	2	×	EC-127
P0037	0037	HO2S2 HTR (B1)	—	2	×	EC-130
P0038	0038	HO2S2 HTR (B1)	—	2	×	EC-130
P0075	0075	INT/V TIM V/CIR-B1	—	2	×	EC-133
P0101	0101	MAF SEN/CIRCUIT-B1	—	2	×	EC-136
P0102	0102	MAF SEN/CIRCUIT-B1	—	1	×	EC-143
P0103	0103	MAF SEN/CIRCUIT-B1	—	1	×	EC-143
P0112	0112	IAT SEN/CIRCUIT-B1	—	2	×	EC-148
P0113	0113	IAT SEN/CIRCUIT-B1	—	2	×	EC-148

ECM

< ECU DIAGNOSIS INFORMATION >

[MR18DE]

DTC*1		Items (CONSULT-III screen terms)	SRT code	Trip	MIL	Reference page
CONSULT-III GST*2	ECM*3					
P0116	0116	ECT SEN/CIRC	—	2	×	EC-150
P0117	0117	ECT SEN/CIRC	—	1	×	EC-152
P0118	0118	ECT SEN/CIRC	—	1	×	EC-152
P0122	0122	TP SEN 2/CIRC-B1	—	1	×	EC-155
P0123	0123	TP SEN 2/CIRC-B1	—	1	×	EC-155
P0125	0125	ECT SENSOR	—	2	×	EC-158
P0127	0127	IAT SENSOR-B1	—	2	×	EC-161
P0128	0128	THERMSTAT FNCTN	—	2	×	EC-163
P0130	0130	A/F SENSOR1 (B1)	—	2	×	EC-165
P0131	0131	A/F SENSOR1 (B1)	—	2	×	EC-169
P0132	0132	A/F SENSOR1 (B1)	—	2	×	EC-172
P0133	0133	A/F SENSOR1 (B1)	×	2	×	EC-175
P0137	0137	HO2S2 (B1)	×	2	×	EC-180
P0138	0138	HO2S2 (B1)	×	2	×	EC-186
P0139	0139	HO2S2 (B1)	×	2	×	EC-194
P0171	0171	FUEL SYS-LEAN-B1	—	2	×	EC-200
P0172	0172	FUEL SYS-RICH-B1	—	2	×	EC-204
P0181	0181	FTT SENSOR	—	2	×	EC-208
P0182	0182	FTT SEN/CIRCUIT	—	2	×	EC-211
P0183	0183	FTT SEN/CIRCUIT	—	2	×	EC-211
P0222	0222	TP SEN 1/CIRC-B1	—	1	×	EC-214
P0223	0223	TP SEN 1/CIRC-B1	—	1	×	EC-214
P0300	0300	MULTI CYL MISFIRE	—	2	×	EC-217
P0301	0301	CYL 1 MISFIRE	—	2	×	EC-217
P0302	0302	CYL 2 MISFIRE	—	2	×	EC-217
P0303	0303	CYL 3 MISFIRE	—	2	×	EC-217
P0304	0304	CYL 4 MISFIRE	—	2	×	EC-217
P0327	0327	KNOCK SEN/CIRC-B1	—	2	—	EC-223
P0328	0328	KNOCK SEN/CIRC-B1	—	2	—	EC-223
P0335	0335	CKP SEN/CIRCUIT	—	2	×	EC-225
P0340	0340	CMP SEN/CIRC-B1	—	2	×	EC-229
P0420	0420	TW CATALYST SYS-B1	×	2	×	EC-233
P0441	0441	EVAP PURG FLOW/MON	×	2	×	EC-238
P0442	0442	EVAP SMALL LEAK	×	2	×	EC-244
P0443	0443	PURG VOLUME CONT/V	—	2	×	EC-251
P0444	0444	PURG VOLUME CONT/V	—	2	×	EC-256
P0445	0445	PURG VOLUME CONT/V	—	2	×	EC-256
P0447	0447	VENT CONTROL VALVE	—	2	×	EC-259
P0448	0448	VENT CONTROL VALVE	—	2	×	EC-263
P0451	0451	EVAP SYS PRES SEN	—	2	×	EC-267
P0452	0452	EVAP SYS PRES SEN	—	2	×	EC-270
P0453	0453	EVAP SYS PRES SEN	—	2	×	EC-275

A

EC

C

D

E

F

G

H

I

J

K

L

M

N

O

P

ECM

< ECU DIAGNOSIS INFORMATION >

[MR18DE]

DTC*1		Items (CONSULT-III screen terms)	SRT code	Trip	MIL	Reference page
CONSULT-III GST*2	ECM*3					
P0455	0455	EVAP GROSS LEAK	—	2	×	EC-281
P0456	0456	EVAP VERY SML LEAK	×*6	2	×	EC-287
P0460	0460	FUEL LEV SEN SLOSH	—	2	×	EC-294
P0461	0461	FUEL LEVEL SENSOR	—	2	×	EC-295
P0462	0462	FUEL LEVL SEN/CIRC	—	2	×	EC-297
P0463	0463	FUEL LEVL SEN/CIRC	—	2	×	EC-297
P0500	0500	VEH SPEED SEN/CIRC*5	—	2	×	EC-299
P0506	0506	ISC SYSTEM	—	2	×	EC-301
P0507	0507	ISC SYSTEM	—	2	×	EC-303
P0605	0605	ECM	—	1 or 2	× or —	EC-305
P0607	0607	ECM	—	1 (CVT) 2 (M/T)	× (CVT) — (M/T)	EC-307
P0643	0643	SENSOR POWER/CIRC	—	1	×	EC-308
P0705	0705	PNP SW/CIRC	—	2	×	TM-101
P0710	0710	ATF TEMP SEN/CIRC*8	—	1	×	TM-104
P0715	0715	INPUT SPD SEN/CIRC	—	2	×	TM-107
P0720	0720	VEH SPD SEN/CIR AT*5	—	2	×	TM-110
P0740	0740	TCC SOLENOID/CIRC	—	2	×	TM-114
P0744	0744	A/T TCC S/V FNCTN	—	2	×	TM-117
P0745	0745	L/PRESS SOL/CIRC	—	2	×	TM-120
P0746	0746	PRS CNT SOL/A FCTN	—	1	×	TM-122
P0776	0776	PRS CNT SOL/B FCTN	—	2	×	TM-124
P0778	0778	PRS CNT SOL/B CIRC	—	2	×	TM-126
P0840	0840	PRS CNT SOL/A CIRC	—	2	×	TM-128
P0850	0850	P-N POS SW/CIRCUIT	—	2	×	EC-310
P1148	1148	CLOSED LOOP-B1	—	1	×	EC-313
P1212	1212	TCS/CIRC	—	2	—	EC-314
P1217	1217	ENG OVER TEMP	—	1	×	EC-315
P1225	1225	CTP LEARNING-B1	—	2	—	EC-319
P1226	1226	CTP LEARNING-B1	—	2	—	EC-321
P1421	1421	COLD START CONTROL	—	2	×	EC-323
P1550	1550	BAT CURRENT SENSOR	—	2	—	EC-325
P1551	1551	BAT CURRENT SENSOR	—	2	—	EC-329
P1552	1552	BAT CURRENT SENSOR	—	2	—	EC-329
P1553	1553	BAT CURRENT SENSOR	—	2	—	EC-333
P1554	1554	BAT CURRENT SENSOR	—	2	—	EC-337
P1564	1564	ASCD SW	—	1	—	EC-341
P1572	1572	ASCD BRAKE SW	—	1	—	EC-344
P1574	1574	ASCD VHL SPD SEN	—	1	—	EC-351
P1610	1610	LOCK MODE	—	2	—	SEC-31
P1611	1611	ID DISCORD, IMMU-ECM	—	2	—	SEC-32
P1612	1612	CHAIN OF ECM-IMMU	—	2	—	SEC-34

DTC*1		Items (CONSULT-III screen terms)	SRT code	Trip	MIL	Reference page
CONSULT-III GST*2	ECM*3					
P1614	1614	CHAIN OF IMMU-KEY	—	2	—	SEC-6
P1615	1615	DIFFERENCE OF KEY	—	2	—	SEC-6
P1715	1715	IN PULY SPEED	—	2	—	EC-353
P1740	1740	LU-SLCT SOL/CIRC	—	2	×	TM-143
P1777	1777	STEP MOTR CIRC	—	1	×	TM-146
P1778	1778	STEP MOTR FNC	—	2	×	TM-149
P1805	1805	BRAKE SW/CIRCUIT	—	2	—	EC-354
P2100	2100	ETC MOT PWR-B1	—	1	×	EC-357
P2101	2101	ETC FNCTN/CIRC-B1	—	1	×	EC-360
P2103	2103	ETC MOT PWR	—	1	×	EC-357
P2118	2118	ETC MOT-B1	—	1	×	EC-364
P2119	2119	ETC ACTR-B1	—	1	×	EC-366
P2122	2122	APP SEN 1/CIRC	—	1	×	EC-368
P2123	2123	APP SEN 1/CIRC	—	1	×	EC-368
P2127	2127	APP SEN 2/CIRC	—	1	×	EC-371
P2128	2128	APP SEN 2/CIRC	—	1	×	EC-371
P2135	2135	TP SENSOR-B1	—	1	×	EC-375
P2138	2138	APP SENSOR	—	1	×	EC-378
P2A00	2A00	A/F SENSOR1 (B1)	—	2	×	EC-382

*1: 1st trip DTC No. is the same as DTC No.

*2: This number is prescribed by SAE J2012.

*3: In Diagnostic Test Mode II (Self-diagnostic results), this number is controlled by NISSAN.

*4: The troubleshooting for this DTC needs CONSULT-III.

*5: When the fail-safe operations for both self-diagnoses occur, the MIL illuminates.

*6: SRT code will not be set if the self-diagnostic result is NG.

*7: When the ECM is in the mode that displays SRT status, MIL may flash. For the details, refer to "How to Display SRT Status" in [EC-451](#), "How to Set SRT Code".

*8: When erasing this DTC, always use CONSULT-III or GST.

How to Set SRT Code

INFOID:000000004833551

To set all SRT codes, self-diagnoses for the SRT items must be performed one or more times. Refer to [EC-85](#), "[Diagnosis Description](#)", "SYSTEM READINESS TEST (SRT) CODE", "SRT Item".

Each diagnosis may require a long period of actual driving under various conditions.

WITH CONSULT-III

Perform corresponding DTC CONFIRMATION PROCEDURE one by one based on Performance Priority in the table on "SRT Item".

WITHOUT CONSULT-III

The most efficient driving pattern in which SRT codes can be properly set is explained below. The driving pattern should be performed one or more times to set all SRT codes.

DRIVING PATTERN

Note: Always drive vehicle in safe manner according to traffic conditions and obey all traffic laws. Refer to next page for more information and explanation of chart.

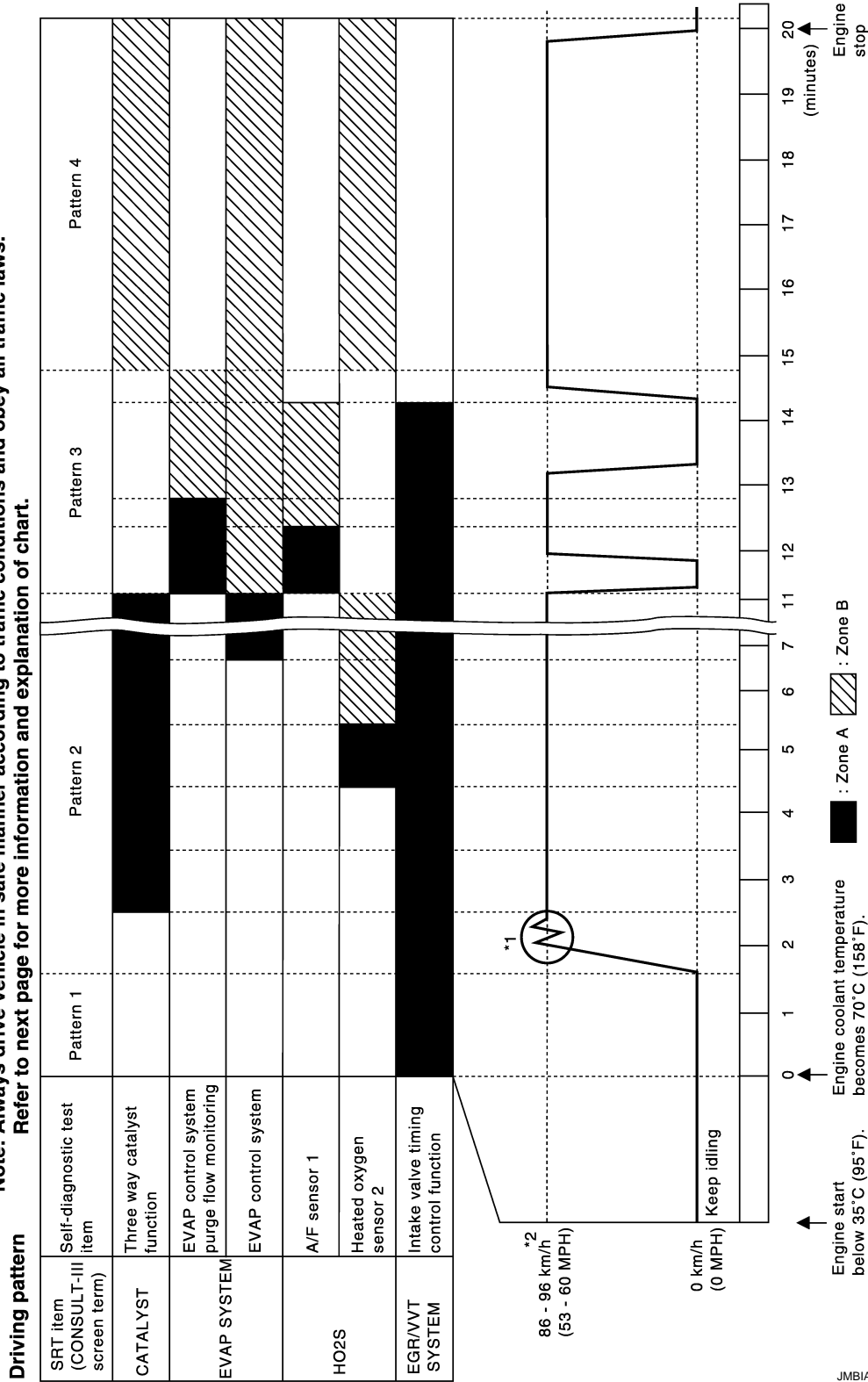

JMBIA2929GB

- The time required for each diagnosis varies with road surface conditions, weather, altitude, individual driving habits, etc.
 Zone A refers to the range where the time, required for the diagnosis under normal conditions*, is the shortest.
 Zone B refers to the range where the diagnosis can still be performed if the diagnosis is not completed within zone A.
- *: Normal conditions refer to the following:

< ECU DIAGNOSIS INFORMATION >

- Sea level
- Flat road
- Ambient air temperature: 20 - 30°C (68 - 86°F)
- Diagnosis is performed as quickly as possible under normal conditions.
- Under different conditions [For example: ambient air temperature other than 20 - 30°C (68 - 86°F)], diagnosis may also be performed.

Pattern 1:

- **The engine is started at the engine coolant temperature of -10 to 35°C (14 to 95°F) (where the voltage between the ECM terminal 38 and ground is 3.0 - 4.3 V).**
- **The engine must be operated at idle speed until the engine coolant temperature is greater than 70°C (158°F) (where the voltage between the ECM terminal 38 and ground is lower than 1.4 V).**
- **The engine is started at the fuel tank temperature of warmer than 0°C (32°F) (where the voltage between the ECM terminal 43 and ground is less than 4.1 V).**

Pattern 2:

- When steady-state driving is performed again even after it is interrupted, each diagnosis can be conducted. In this case, the time required for diagnosis may be extended.

Pattern 3:

- Operate vehicle following the driving pattern shown in the figure.
- Release the accelerator pedal during decelerating vehicle speed from 90 km/h (56 MPH) to 0 km/h (0 MPH).

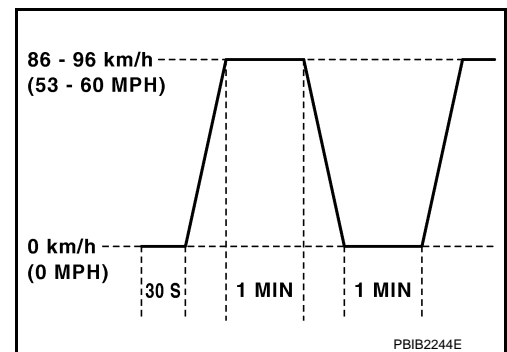

Pattern 4:

- The accelerator pedal must be held very steady during steady-state driving.
- If the accelerator pedal is moved, the test must be conducted again.

*1: Depress the accelerator pedal until vehicle speed is 90 km/h (56 MPH), then release the accelerator pedal and keep it released for more than 10 seconds. Depress the accelerator pedal until vehicle speed is 90 km/h (56 MPH) again.

*2: Checking the vehicle speed with GST is advised.

Suggested Transmission Gear Position for Models

Set the selector lever in the D position.

Suggested Upshift Speeds for M/T Models

Shown below are suggested vehicle speeds for shifting into a higher gear. These suggestions relate to fuel economy and vehicle performance. Actual upshift speeds will vary according to road conditions, the weather and individual driving habits.

Gear change	For normal acceleration in low altitude areas [less than 1,219 m (4,000 ft):		For quick acceleration in low altitude areas and high altitude areas [over 1,219 m (4,000 ft):
	ACCEL shift position [km/h (MPH)]	CRUISE shift point [km/h (MPH)]	km/h (MPH)
1st to 2nd	15 (9)	21 (13)	15 (9)
2nd to 3rd	25 (16)	38 (24)	30 (19)
3rd to 4th	40 (25)	55 (34)	45 (28)
4th to 5th	45 (28)	74 (46)	50 (31)

Test Value and Test Limit

INFOID:000000004833552

The following is the information specified in Service \$06 of SAE J1979.

The test value is a parameter used to determine whether a system/circuit diagnostic test is OK or NG while being monitored by the ECM during self-diagnosis. The test limit is a reference value which is specified as the maximum or minimum value and is compared with the test value being monitored.

These data (test value and test limit) are specified by On Board Monitor ID(OBDMID), Test ID (TID), Unit and Scaling ID and can be displayed on the GST screen.

The items of the test value and test limit will be displayed with GST screen which items are provided by the ECM. (eg., if bank 2 is not applied on this vehicle, only the items of bank 1 are displayed)

ECM

< ECU DIAGNOSIS INFORMATION >

[MR18DE]

Item	OBD-MID	Self-diagnostic test item	DTC	Test value and Test limit (GST display)		Description
				TID	Unit and Scaling ID	
HO2S	01H	Air fuel ratio (A/F) sensor 1 (Bank 1)	P0131	83H	0BH	Minimum sensor output voltage for test cycle
			P0131	84H	0BH	Maximum sensor output voltage for test cycle
			P0130	85H	0BH	Minimum sensor output voltage for test cycle
			P0130	86H	0BH	Maximum sensor output voltage for test cycle
			P0133	87H	04H	Response rate: Response ratio (Lean to Rich)
			P0133	88H	04H	Response rate: Response ratio (Rich to Lean)
			P2A00	89H	84H	The amount of shift in air fuel ratio
			P2A00	8AH	84H	The amount of shift in air fuel ratio
			P0130	8BH	0BH	Difference in sensor output voltage
			P0133	8CH	83H	Response gain at the limited frequency
	02H	Heated oxygen sensor 2 (Bank 1)	P0138	07H	0CH	Minimum sensor output voltage for test cycle
			P0137	08H	0CH	Maximum sensor output voltage for test cycle
			P0138	80H	0CH	Sensor output voltage
			P0139	81H	0CH	Difference in sensor output voltage
	03H	Heated oxygen sensor 3 (Bank 1)	P0143	07H	0CH	Minimum sensor output voltage for test cycle
P0144			08H	0CH	Maximum sensor output voltage for test cycle	
P0146			80H	0CH	Sensor output voltage	
P0145			81H	0CH	Difference in sensor output voltage	

ECM

< ECU DIAGNOSIS INFORMATION >

[MR18DE]

Item	OBD-MID	Self-diagnostic test item	DTC	Test value and Test limit (GST display)		Description
				TID	Unit and Scaling ID	
HO2S	05H	Air fuel ratio (A/F) sensor 1 (Bank 2)	P0151	83H	0BH	Minimum sensor output voltage for test cycle
			P0151	84H	0BH	Maximum sensor output voltage for test cycle
			P0150	85H	0BH	Minimum sensor output voltage for test cycle
			P0150	86H	0BH	Maximum sensor output voltage for test cycle
			P0153	87H	04H	Response rate: Response ratio (Lean to Rich)
			P0153	88H	04H	Response rate: Response ratio (Rich to Lean)
			P2A03	89H	84H	The amount of shift in air fuel ratio
			P2A03	8AH	84H	The amount of shift in air fuel ratio
			P0150	8BH	0BH	Difference in sensor output voltage
			P0153	8CH	83H	Response gain at the limited frequency
	06H	Heated oxygen sensor 2 (Bank 2)	P0158	07H	0CH	Minimum sensor output voltage for test cycle
			P0157	08H	0CH	Maximum sensor output voltage for test cycle
			P0158	80H	0CH	Sensor output voltage
			P0159	81H	0CH	Difference in sensor output voltage
	07H	Heated oxygen sensor 3 (Bank2)	P0163	07H	0CH	Minimum sensor output voltage for test cycle
P0164			08H	0CH	Maximum sensor output voltage for test cycle	
P0166			80H	0CH	Sensor output voltage	
P0165			81H	0CH	Difference in sensor output voltage	
CATA- LYST	21H	Three way catalyst function (Bank1)	P0420	80H	01H	O2 storage index
			P0420	82H	01H	Switching time lag engine exhaust index value
			P2423	83H	0CH	Difference in 3rd O2 sensor output voltage
			P2423	84H	84H	O2 storage index in HC trap catalyst
	22H	Three way catalyst function (Bank2)	P0430	80H	01H	O2 storage index
			P0430	82H	01H	Switching time lag engine exhaust index value
			P2424	83H	0CH	Difference in 3rd O2 sensor output voltage
			P2424	84H	84H	O2 storage index in HC trap catalyst

A
EC
C
D
E
F
G
H
I
J
K
L
M
N
O
P

ECM

< ECU DIAGNOSIS INFORMATION >

[MR18DE]

Item	OBD-MID	Self-diagnostic test item	DTC	Test value and Test limit (GST display)		Description
				TID	Unit and Scaling ID	
EGR SYSTEM	31H	EGR function	P0400	80H	96H	Low Flow Faults: EGR temp change rate (short term)
			P0400	81H	96H	Low Flow Faults: EGR temp change rate (long term)
			P0400	82H	96H	Low Flow Faults: Difference between max EGR temp and EGR temp under idling condition
			P0400	83H	96H	Low Flow Faults: Max EGR temp
			P1402	84H	96H	High Flow Faults: EGR temp increase rate
VVT SYSTEM	35H	VVT Monitor (Bank1)	P0011	80H	9DH	VTC intake function diagnosis (VTC alignment check diagnosis)
			P0014	81H	9DH	VTC exhaust function diagnosis (VTC alignment check diagnosis)
			P0011	82H	9DH	VTC intake function diagnosis (VTC drive failure diagnosis)
			P0014	83H	9DH	VTC exhaust function diagnosis (VTC drive failure diagnosis)
	36H	VVT Monitor (Bank2)	P0021	80H	9DH	VTC intake function diagnosis (VTC alignment check diagnosis)
			P0024	81H	9DH	VTC exhaust function diagnosis (VTC alignment check diagnosis)
			P0021	82H	9DH	VTC intake function diagnosis (VTC drive failure diagnosis)
			P0024	83H	9DH	VTC exhaust function diagnosis (VTC drive failure diagnosis)
EVAP SYSTEM	39H	EVAP control system leak (Cap Off)	P0455	80H	0CH	Difference in pressure sensor output voltage before and after pull down
	3BH	EVAP control system leak (Small leak)	P0442	80H	05H	Leak area index (for more than 0.04 inch)
	3CH	EVAP control system leak (Very small leak)	P0456	80H	05H	Leak area index (for more than 0.02 inch)
			P0456	81H	FDH	Maximum internal pressure of EVAP system during monitoring
	3DH	Purge flow system	P0441	83H	0CH	Difference in pressure sensor output voltage before and after vent control valve close
O2 SENSOR HEATER	41H	A/F sensor 1 heater (Bank 1)	Low Input:P0031 High Input:P0032	81H	0BH	Converted value of Heater electric current to voltage
	42H	Heated oxygen sensor 2 heater (Bank 1)	Low Input:P0037 High Input:P0038	80H	0CH	Converted value of Heater electric current to voltage
	43H	Heated oxygen sensor 3 heater (Bank 1)	P0043	80H	0CH	Converted value of Heater electric current to voltage
	45H	A/F sensor 1 heater (Bank 2)	Low Input:P0051 High Input:P0052	81H	0BH	Converted value of Heater electric current to voltage
	46H	Heated oxygen sensor 2 heater (Bank 2)	Low Input:P0057 High Input:P0058	80H	0CH	Converted value of Heater electric current to voltage
	47H	Heated oxygen sensor 3 heater (Bank 2)	P0063	80H	0CH	Converted value of Heater electric current to voltage

ECM

< ECU DIAGNOSIS INFORMATION >

[MR18DE]

Item	OBD-MID	Self-diagnostic test item	DTC	Test value and Test limit (GST display)		Description
				TID	Unit and Scaling ID	
SEC- OND- ARY AIR	71H	Secondary Air system	P0411	80H	01H	Secondary Air Injection System Incorrect Flow Detected
			Bank1: P0491 Bank2: P0492	81H	01H	Secondary Air Injection System Insufficient Flow
			P2445	82H	01H	Secondary Air Injection System Pump Stuck Off
			P2448	83H	01H	Secondary Air Injection System High Airflow
			Bank1: P2440 Bank2: P2442	84H	01H	Secondary Air Injection System Switching Valve Stuck Open
			P2440	85H	01H	Secondary Air Injection System Switching Valve Stuck Open
			P2444	86H	01H	Secondary Air Injection System Pump Stuck On
FUEL SYSTEM	81H	Fuel injection system function (Bank 1)	P0171 or P0172	80H	2FH	Long term fuel trim
			P0171 or P0172	81H	24H	The number of lambda control clamped
	82H	Fuel injection system function (Bank 2)	P0174 or P0175	80H	2FH	Long term fuel trim
			P0174 or P0175	81H	24H	The number of lambda control clamped

A
EC
C
D
E
F
G
H
I
J
K
L
M
N
O
P

ECM

< ECU DIAGNOSIS INFORMATION >

[MR18DE]

Item	OBD-MID	Self-diagnostic test item	DTC	Test value and Test limit (GST display)		Description
				TID	Unit and Scaling ID	
MISFIRE	A1H	Multiple Cylinder Misfires	P0301	80H	24H	Misfiring counter at 1000 revolution of the first cylinder
			P0302	81H	24H	Misfiring counter at 1000 revolution of the second cylinder
			P0303	82H	24H	Misfiring counter at 1000 revolution of the third cylinder
			P0304	83H	24H	Misfiring counter at 1000 revolution of the fourth cylinder
			P0305	84H	24H	Misfiring counter at 1000 revolution of the fifth cylinder
			P0306	85H	24H	Misfiring counter at 1000 revolution of the sixth cylinder
			P0307	86H	24H	Misfiring counter at 1000 revolution of the seventh cylinder
			P0308	87H	24H	Misfiring counter at 1000 revolution of the eighth cylinder
			P0300	88H	24H	Misfiring counter at 1000 revolution of the multiple cylinders
			P0301	89H	24H	Misfiring counter at 200 revolution of the first cylinder
			P0302	8AH	24H	Misfiring counter at 200 revolution of the second cylinder
			P0303	8BH	24H	Misfiring counter at 200 revolution of the third cylinder
			P0304	8CH	24H	Misfiring counter at 200 revolution of the fourth cylinder
			P0305	8DH	24H	Misfiring counter at 200 revolution of the fifth cylinder
			P0306	8EH	24H	Misfiring counter at 200 revolution of the sixth cylinder
			P0307	8FH	24H	Misfiring counter at 200 revolution of the seventh cylinder
			P0308	90H	24H	Misfiring counter at 200 revolution of the eighth cylinder
			P0300	91H	24H	Misfiring counter at 1000 revolution of the single cylinder
			P0300	92H	24H	Misfiring counter at 200 revolution of the single cylinder
			P0300	93H	24H	Misfiring counter at 200 revolution of the multiple cylinders

ECM

< ECU DIAGNOSIS INFORMATION >

[MR18DE]

Item	OBD-MID	Self-diagnostic test item	DTC	Test value and Test limit (GST display)		Description
				TID	Unit and Scaling ID	
MISFIRE	A2H	No. 1 Cylinder Misfire	P0301	0BH	24H	EWMA (Exponential Weighted Moving Average) misfire counts for last 10 driving cycles
			P0301	0CH	24H	Misfire counts for last/current driving cycles
	A3H	No. 2 Cylinder Misfire	P0302	0BH	24H	EWMA (Exponential Weighted Moving Average) misfire counts for last 10 driving cycles
			P0302	0CH	24H	Misfire counts for last/current driving cycles
	A4H	No. 3 Cylinder Misfire	P0303	0BH	24H	EWMA (Exponential Weighted Moving Average) misfire counts for last 10 driving cycles
			P0303	0CH	24H	Misfire counts for last/current driving cycles
	A5H	No. 4 Cylinder Misfire	P0304	0BH	24H	EWMA (Exponential Weighted Moving Average) misfire counts for last 10 driving cycles
			P0304	0CH	24H	Misfire counts for last/current driving cycles
	A6H	No. 5 Cylinder Misfire	P0305	0BH	24H	EWMA (Exponential Weighted Moving Average) misfire counts for last 10 driving cycles
			P0305	0CH	24H	Misfire counts for last/current driving cycles
	A7H	No. 6 Cylinder Misfire	P0306	0BH	24H	EWMA (Exponential Weighted Moving Average) misfire counts for last 10 driving cycles
			P0306	0CH	24H	Misfire counts for last/current driving cycles
	A8H	No. 7 Cylinder Misfire	P0307	0BH	24H	EWMA (Exponential Weighted Moving Average) misfire counts for last 10 driving cycles
			P0307	0CH	24H	Misfire counts for last/current driving cycles
	A9H	No. 8 Cylinder Misfire	P0308	0BH	24H	EWMA (Exponential Weighted Moving Average) misfire counts for last 10 driving cycles
			P0308	0CH	24H	Misfire counts for last/current driving cycles

A
EC
C
D
E
F
G
H
I
J
K
L
M
N
O
P

ENGINE CONTROL SYSTEM SYMPTOMS

< SYMPTOM DIAGNOSIS >

[MR18DE]

SYMPTOM DIAGNOSIS

ENGINE CONTROL SYSTEM SYMPTOMS

Symptom Table

INFOID:000000005040146

SYSTEM — BASIC ENGINE CONTROL SYSTEM

		SYMPTOM													Reference page
		HARD/NO START/RESTART (EXCP. HA)	ENGINE STALL	HESITATION/SURGING/FLAT SPOT	SPARK KNOCK/DETONATION	LACK OF POWER/POOR ACCELERATION	HIGH IDLE/LOW IDLE	ROUGH IDLE/HUNTING	IDLING VIBRATION	SLOW/NO RETURN TO IDLE	OVERHEATS/WATER TEMPERATURE HIGH	EXCESSIVE FUEL CONSUMPTION	EXCESSIVE OIL CONSUMPTION	BATTERY DEAD (UNDER CHARGE)	
Warranty symptom code		AA	AB	AC	AD	AE	AF	AG	AH	AJ	AK	AL	AM	HA	
Fuel	Fuel pump circuit	1	1	2	3	2		2	2			3		2	EC-398
	Fuel pressure regulator system	3	3	4	4	4	4	4	4	4		4			EC-471
	Fuel injector circuit	1	1	2	3	2		2	2			2			EC-395
	Evaporative emission system	3	3	4	4	4	4	4	4	4	4	4			EC-68
Air	Positive crankcase ventilation system	3	3	4	4	4	4	4	4	4		4	1		EC-413
	Incorrect idle speed adjustment						1	1	1	1		1			EC-16
	Electric throttle control actuator	1	1	2	3	3	2	2	2	2		2		2	EC-360 EC-364
Ignition	Incorrect ignition timing adjustment	3	3	1	1	1		1	1			1			EC-16
	Ignition circuit	1	1	2	2	2		2	2			2			EC-401
Main power supply and ground circuit		2	2	3	3	3		3	3		2	3			EC-117
Mass air flow sensor circuit		1			2										EC-136 EC-143
Engine coolant temperature sensor circuit							3			3					EC-150 EC-152
Air fuel ratio (A/F) sensor 1 circuit			1	2	3	2		2	2			2			EC-165 EC-169 EC-172 EC-175 EC-382
Throttle position sensor circuit							2			2					EC-155 EC-214 EC-319 EC-321 EC-375
Accelerator pedal position sensor circuit				3	2	1									EC-368 EC-371 EC-378
Knock sensor circuit				2								3			EC-223

ENGINE CONTROL SYSTEM SYMPTOMS

< SYMPTOM DIAGNOSIS >

[MR18DE]

	SYMPTOM													Reference page
	HARD/NO START/RESTART (EXCP. HA)	ENGINE STALL	HESITATION/SURGING/FLAT SPOT	SPARK KNOCK/DETONATION	LACK OF POWER/POOR ACCELERATION	HIGH IDLE/LOW IDLE	ROUGH IDLE/HUNTING	IDLING VIBRATION	SLOW/NO RETURN TO IDLE	OVERHEATS/WATER TEMPERATURE HIGH	EXCESSIVE FUEL CONSUMPTION	EXCESSIVE OIL CONSUMPTION	BATTERY DEAD (UNDER CHARGE)	
Warranty symptom code	AA	AB	AC	AD	AE	AF	AG	AH	AJ	AK	AL	AM	HA	
Crankshaft position sensor (POS) circuit	2	2												EC-225
Camshaft position sensor (PHASE) circuit	3	2												EC-229
Vehicle speed signal circuit		2	3		3						3			EC-299
ECM	2	2	3	3	3	3	3	3	3	3	3			EC-305 EC-307
Intake valve timing control solenoid valve circuit		3	2		1	3	2	2	3		3			EC-123
transmission range switch circuit			3		3		3	3			3			EC-310
PNP switch circuit			3		3		3	3			3			EC-310
Refrigerant pressure sensor circuit		2				3			3		4			EC-414
Electrical load signal circuit							3							EC-393
Air conditioner circuit	2	2	3	3	3	3	3	3	3		3		2	HAC-212
ABS actuator and electric unit (control unit)			4											BRC-85

1 - 6: The numbers refer to the order of inspection.
(continued on next table)

SYSTEM — ENGINE MECHANICAL & OTHER

A
EC
C
D
E
F
G
H
I
J
K
L
M
N
O
P

ENGINE CONTROL SYSTEM SYMPTOMS

< SYMPTOM DIAGNOSIS >

[MR18DE]

		SYMPTOM													Reference page																				
		HARD/NO START/RESTART (EXCP. HA)	ENGINE STALL	HESITATION/SURGING/FLAT SPOT	SPARK KNOCK/DETONATION	LACK OF POWER/POOR ACCELERATION	HIGH IDLE/LOW IDLE	ROUGH IDLE/HUNTING	IDLING VIBRATION	SLOW/NO RETURN TO IDLE	OVERHEAT/WATER TEMPERATURE HIGH	EXCESSIVE FUEL CONSUMPTION	EXCESSIVE OIL CONSUMPTION	BATTERY DEAD (UNDER CHARGE)																					
Warranty symptom code		A A	AB	AC	AD	AE	AF	AG	AH	AJ	AK	AL	AM	HA																					
Fuel	Fuel tank	5	5												FL-13																				
	Fuel piping			5	5	5		5	5			5			FL-4																				
	Vapor lock	5														—																			
	Valve deposit																—																		
	Poor fuel (Heavy weight gasoline, Low octane)			5	5	5	5		5	5			5				—																		
Air	Air duct	5	5	5	5	5	5	5	5	5	5	5	5	5	5	EM-15																			
	Air cleaner																																		
	Air leakage from air duct (Mass air flow sensor — electric throttle control actuator)																																		
	Electric throttle control actuator																																		
	Air leakage from intake manifold/Collector/Gasket																																		
Cranking	Battery	1	1	1		1		1	1						1	PG-3																			
	Generator circuit															CHG-5																			
	Starter circuit	3											1			STR-2																			
	Signal plate	6														EM-86																			
	Transmission range switch	4														TM-101 (CVT)																			
	PNP switch	4														TM-8 (M/T)																			
Engine	Cylinder head	5	5	5	5	5	5	5	5	5	5	5	5	5	5	5	EM-65																		
	Cylinder head gasket																	4		3															
	Cylinder block	6																6	6	6	6	6	6	6	6	6	6	6	6	6	6	EM-86			
	Piston																																		4
	Piston ring																																		
	Connecting rod																																		
	Bearing																																		
	Crankshaft																																		

ENGINE CONTROL SYSTEM SYMPTOMS

< SYMPTOM DIAGNOSIS >

[MR18DE]

		SYMPTOM												Reference page	
		HARD/NO START/RESTART (EXCP. HA)	ENGINE STALL	HESITATION/SURGING/FLAT SPOT	SPARK KNOCK/DETONATION	LACK OF POWER/POOR ACCELERATION	HIGH IDLE/LOW IDLE	ROUGH IDLE/HUNTING	IDLING VIBRATION	SLOW/NO RETURN TO IDLE	OVERHEATS/WATER TEMPERATURE HIGH	EXCESSIVE FUEL CONSUMPTION	EXCESSIVE OIL CONSUMPTION		BATTERY DEAD (UNDER CHARGE)
Warranty symptom code		A A	AB	AC	AD	AE	AF	AG	AH	AJ	AK	AL	AM	HA	
Valve mechanism	Timing chain														EM-42
	Camshaft														EM-53
	Intake valve timing control	5	5	5	5	5		5	5			5			EM-42
	Intake valve														EM-65
	Exhaust valve												3		
Exhaust	Exhaust manifold/Tube/Muffler/Gasket	5	5	5	5	5		5	5			5			EM-29 EX-4
	Three way catalyst														
Lubrication	Oil pan/Oil strainer/Oil pump/Oil filter/Oil gallery/Oil cooler	5	5	5	5	5		5	5			5			EM-32 LU-7 LU-11
	Oil level (Low)/Filthy oil														LU-7
Cooling	Radiator/Hose/Radiator filler cap														CO-12 CO-12
	Thermostat									5					CO-20
	Water pump														CO-18
	Water gallery	5	5	5	5	5		5	5		4	5			CO-2
	Cooling fan														EC-391
	Coolant level (Low)/Contaminated coolant										5				
NVIS (NISSAN Vehicle Immobilizer System — NATS)		1	1												SEC-15

1 - 6: The numbers refer to the order of inspection.

A
EC
C
D
E
F
G
H
I
J
K
L
M
N
O
P

NORMAL OPERATING CONDITION

Description

INFOID:000000004833554

FUEL CUT CONTROL (AT NO LOAD AND HIGH ENGINE SPEED)

If the engine speed is above 2,500 rpm under no load (for example, the selector lever position is neutral and engine speed is over 2,500 rpm) fuel will be cut off after some time. The exact time when the fuel is cut off varies based on engine speed.

Fuel cut will be operated until the engine speed reaches 2,000 rpm, then fuel cut will be cancelled.

NOTE:

This function is different from deceleration control listed under Multiport Fuel Injection (MFI) System, [EC-28](#), "[System Description](#)".

PRECAUTION

PRECAUTIONS

Precaution for Supplemental Restraint System (SRS) "AIR BAG" and "SEAT BELT PRE-TENSIONER"

INFOID:000000004833555

The Supplemental Restraint System such as "AIR BAG" and "SEAT BELT PRE-TENSIONER", used along with a front seat belt, helps to reduce the risk or severity of injury to the driver and front passenger for certain types of collision. This system includes seat belt switch inputs and dual stage front air bag modules. The SRS system uses the seat belt switches to determine the front air bag deployment, and may only deploy one front air bag, depending on the severity of a collision and whether the front occupants are belted or unbelted. Information necessary to service the system safely is included in the "SUPPLEMENTAL RESTRAINT SYSTEM" and "SEAT BELTS" of this Service Manual.

WARNING:

- To avoid rendering the SRS inoperative, which could increase the risk of personal injury or death in the event of a collision which would result in air bag inflation, all maintenance must be performed by an authorized NISSAN/INFINITI dealer.
- Improper maintenance, including incorrect removal and installation of the SRS, can lead to personal injury caused by unintentional activation of the system. For removal of Spiral Cable and Air Bag Module, see the "SUPPLEMENTAL RESTRAINT SYSTEM".
- Do not use electrical test equipment on any circuit related to the SRS unless instructed to in this Service Manual. SRS wiring harnesses can be identified by yellow and/or orange harnesses or harness connectors.

PRECAUTIONS WHEN USING POWER TOOLS (AIR OR ELECTRIC) AND HAMMERS

WARNING:

- When working near the Air Bag Diagnosis Sensor Unit or other Air Bag System sensors with the ignition ON or engine running, DO NOT use air or electric power tools or strike near the sensor(s) with a hammer. Heavy vibration could activate the sensor(s) and deploy the air bag(s), possibly causing serious injury.
- When using air or electric power tools or hammers, always switch the ignition OFF, disconnect the battery, and wait at least 3 minutes before performing any service.

Precaution for Procedure without Cowl Top Cover

INFOID:000000004833556

When performing the procedure after removing cowl top cover, cover the lower end of windshield with urethane, etc.

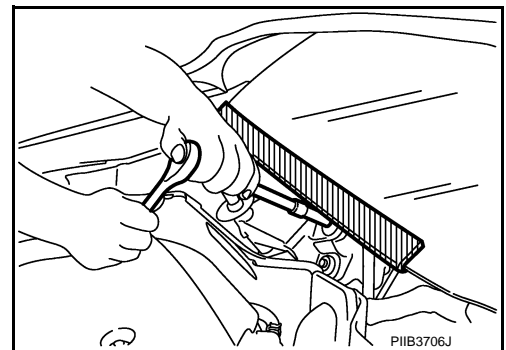

On Board Diagnosis (OBD) System of Engine and CVT

INFOID:000000004833557

The ECM has an on board diagnostic system. It will light up the malfunction indicator lamp (MIL) to warn the driver of a malfunction causing emission deterioration.

CAUTION:

- Be sure to turn the ignition switch OFF and disconnect the negative battery cable before any repair or inspection work. The open/short circuit of related switches, sensors, solenoid valves, etc. will cause the MIL to light up.
- Be sure to connect and lock the connectors securely after work. A loose (unlocked) connector will cause the MIL to light up due to the open circuit. (Be sure the connector is free from water, grease, dirt, bent terminals, etc.)
- Certain systems and components, especially those related to OBD, may use a new style slide-locking type harness connector. For description and how to disconnect, refer to [PG-85, "Description"](#).

A
EC
C
D
E
F
G
H
I
J
K
L
M
N
O
P

PRECAUTIONS

[MR18DE]

< PRECAUTION >

- Be sure to route and secure the harnesses properly after work. The interference of the harness with a bracket, etc. may cause the MIL to light up due to the short circuit.
- Be sure to connect rubber tubes properly after work. A misconnected or disconnected rubber tube may cause the MIL to light up due to the malfunction of the EVAP system or fuel injection system, etc.
- Be sure to erase the unnecessary malfunction information (repairs completed) from the ECM and TCM (Transmission control module) before returning the vehicle to the customer.

General Precautions

INFOID:000000004833558

- Always use a 12 volt battery as power source.
- Do not attempt to disconnect battery cables while engine is running.
- Before connecting or disconnecting the ECM harness connector, turn ignition switch OFF and disconnect negative battery cable. Failure to do so may damage the ECM because battery voltage is applied to ECM even if ignition switch is turned OFF.
- Before removing parts, turn ignition switch OFF and then disconnect negative battery cable.

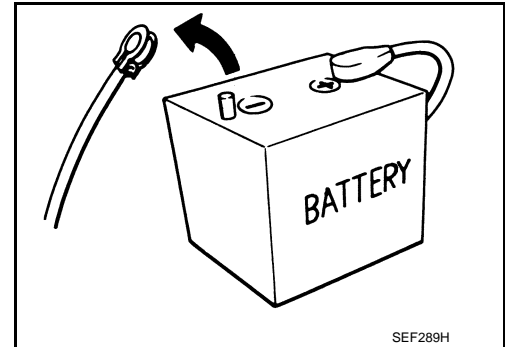

- Do not disassemble ECM.
- If a battery cable is disconnected, the memory will return to the ECM value.
The ECM will now start to self-control at its initial value. Thus, engine operation can vary slightly in this case. However, this is not an indication of a malfunction. Do not replace parts because of a slight variation.
- If the battery is disconnected, the following emission-related diagnostic information will be cleared within 24 hours.
 - Diagnostic trouble codes
 - 1st trip diagnostic trouble codes
 - Freeze frame data
 - 1st trip freeze frame data
 - System readiness test (SRT) codes
 - Test values
- When connecting ECM harness connector (1), fasten (B) it securely with a lever as far as it will go as shown in the figure.

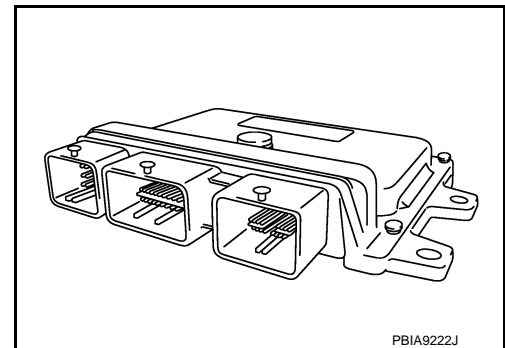

- 2. ECM
- A. Loosen

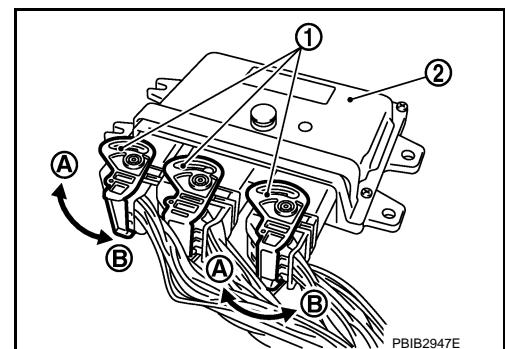

- When connecting or disconnecting pin connectors into or from ECM, take care not to damage pin terminals (bend or break).
Make sure that there are not any bends or breaks on ECM pin terminal, when connecting pin connectors.
- Securely connect ECM harness connectors.
A poor connection can cause an extremely high (surge) voltage to develop in coil and condenser, thus resulting in damage to ICs.
- Keep engine control system harness at least 10 cm (4 in) away from adjacent harness, to prevent engine control system mal-

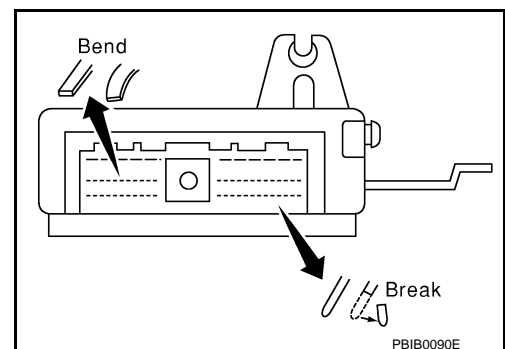

PRECAUTIONS

[MR18DE]

< PRECAUTION >

functions due to receiving external noise, degraded operation of ICs, etc.

- Keep engine control system parts and harness dry.
- Before replacing ECM, perform ECM Terminals and Reference Value inspection and make sure ECM functions properly. Refer to [EC-416, "Reference Value"](#).
- Handle mass air flow sensor carefully to avoid damage.
- Do not clean mass air flow sensor with any type of detergent.
- Do not disassemble electric throttle control actuator.
- Even a slight leak in the air intake system can cause serious incidents.
- Do not shock or jar the camshaft position sensor (PHASE), crankshaft position sensor (POS).

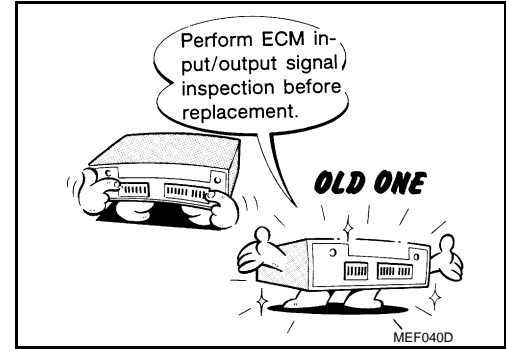

- After performing each TROUBLE DIAGNOSIS, perform DTC CONFIRMATION PROCEDURE or Component Function Check. The DTC should not be displayed in the DTC Confirmation Procedure if the repair is completed. The Component Function Check should be a good result if the repair is completed.

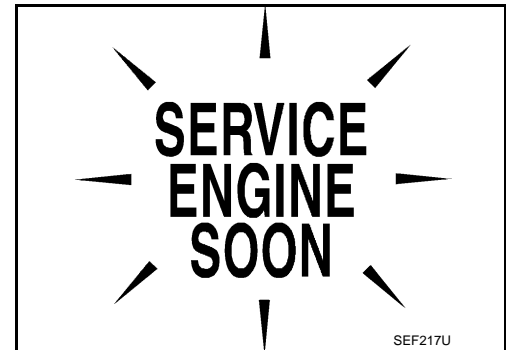

- When measuring ECM signals with a circuit tester, never allow the two tester probes to contact. Accidental contact of probes will cause a short circuit and damage the ECM power transistor.

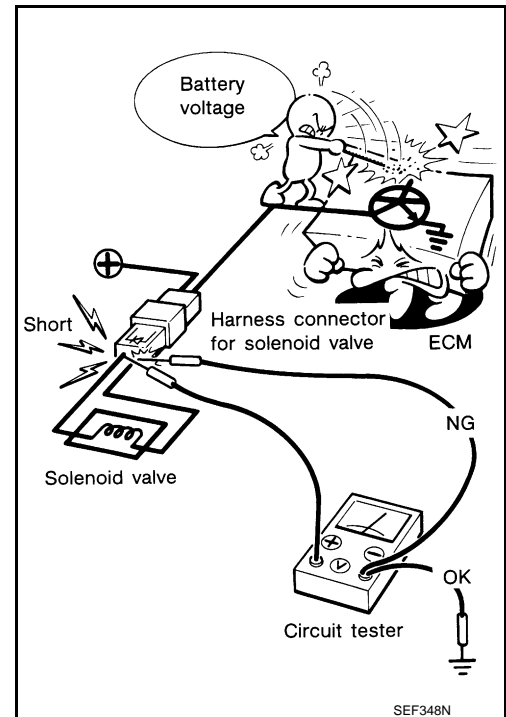

A
EC
C
D
E
F
G
H
I
J
K
L
M
N
O
P

PRECAUTIONS

[MR18DE]

< PRECAUTION >

- Do not operate fuel pump when there is no fuel in lines.
- Tighten fuel hose clamps to the specified torque.
 - Fuel level sensor unit and fuel pump (1)
 - Fuel pressure regulator (2)
 - Fuel level sensor (3)
 - Fuel tank temperature sensor (4)

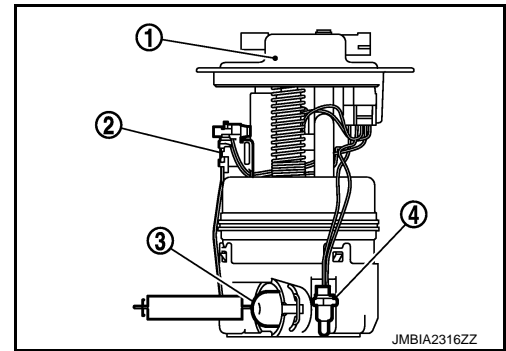

- Do not depress accelerator pedal when starting.
- Immediately after starting, do not rev up engine unnecessarily.
- Do not rev up engine just prior to shutdown.

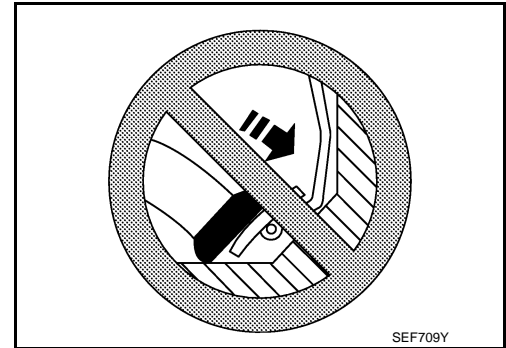

- When installing C.B. ham radio or a mobile phone, be sure to observe the following as it may adversely affect electronic control systems depending on installation location.
 - Keep the antenna as far as possible from the electronic control units.
 - Keep the antenna feeder line more than 20 cm (8 in) away from the harness of electronic controls. Do not let them run parallel for a long distance.
 - Adjust the antenna and feeder line so that the standing-wave ratio can be kept smaller.
 - Be sure to ground the radio to vehicle body.

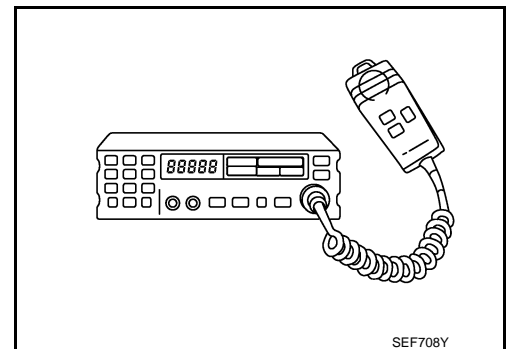

PREPARATION

< PREPARATION >

[MR18DE]

PREPARATION

PREPARATION

Special Service Tools

INFOID:000000004833559

A

EC

NOTE:

The actual shapes of Kent-Moore tools may differ from those of special service tools illustrated here.

C

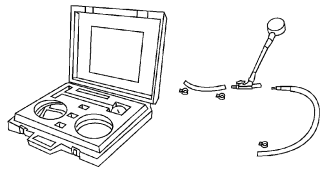
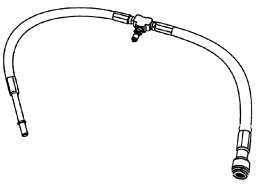
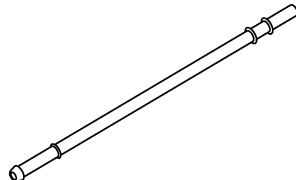
Tool number (Kent-Moore No.) Tool name	Description
(J-44321) Fuel pressure gauge kit  LEC642	Checks fuel pressure
(J-44321-6) Fuel pressure adapter  LBIA0376E	Connects fuel pressure gauge to quick connector type fuel lines.
KV10118400 Fuel tube adapter  PBIB3043E	Measures fuel pressure

D

E

F

G

H

I

J

K

Commercial Service Tools

INFOID:000000004833560

L

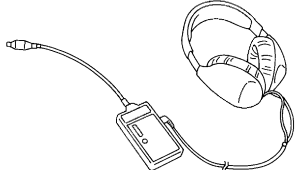
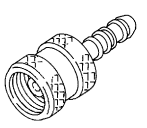
Tool name (Kent-Moore No.)	Description
Leak detector i.e.: (J-41416)  S-NT703	Locates the EVAP leak
EVAP service port adapter i.e.: (J-41413-OBD)  S-NT704	Applies positive pressure through EVAP service port

M

N

O

P

PREPARATION

[MR18DE]

< PREPARATION >

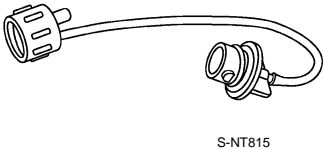
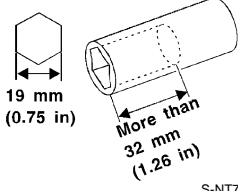
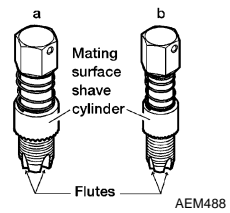
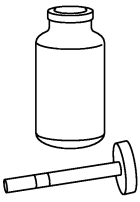
Tool name (Kent-Moore No.)	Description
Fuel filler cap adapter i.e.: (MLR-8382) <div data-bbox="516 310 836 457" style="text-align: center;">  <p>S-NT815</p> </div>	Checks fuel tank vacuum relief valve opening pressure
Socket wrench <div data-bbox="535 514 771 703" style="text-align: center;">  <p>S-NT705</p> </div>	Removes and installs engine coolant temperature sensor
Oxygen sensor thread cleaner i.e.: (J-43897-18) (J-43897-12) <div data-bbox="560 756 787 966" style="text-align: center;">  <p>AEM488</p> </div>	Reconditions the exhaust system threads before installing a new oxygen sensor. Use with anti-seize lubricant shown below. a: 18 mm diameter with pitch 1.5 mm for Zirconia Oxygen Sensor b: 12 mm diameter with pitch 1.25 mm for Titanium Oxygen Sensor
Anti-seize lubricant i.e.: (Permatex™ 133AR or equivalent meeting MIL specification MIL-A-907) <div data-bbox="576 1018 714 1218" style="text-align: center;">  <p>S-NT779</p> </div>	Lubricates oxygen sensor thread cleaning tool when reconditioning exhaust system threads.

PERIODIC MAINTENANCE

FUEL PRESSURE

Inspection

INFOID:000000004833561

FUEL PRESSURE RELEASE

④ With CONSULT-III

1. Turn ignition switch ON.
2. Perform "FUEL PRESSURE RELEASE" in "WORK SUPPORT" mode with CONSULT-III.
3. Start engine.
4. After engine stalls, crank it two or three times to release all fuel pressure.
5. Turn ignition switch OFF.

⊗ Without CONSULT-III

1. Remove fuel pump fuse located in IPDM E/R.
2. Start engine.
3. After engine stalls, crank it two or three times to release all fuel pressure.
4. Turn ignition switch OFF.
5. Reinstall fuel pump fuse after servicing fuel system.

FUEL PRESSURE CHECK

CAUTION:

Before disconnecting fuel line, release fuel pressure from fuel line to eliminate danger.

NOTE:

- Prepare pans or saucers under the disconnected fuel line because the fuel may spill out. The fuel pressure cannot be completely released because C11 models do not have fuel return system.
- The fuel hose connection method used when taking fuel pressure check must not be used for other purposes.
- Be careful not to scratch or put debris around connection area when servicing, so that the quick connector maintains seal ability with O-rings inside.
- Do not perform fuel pressure check with electrical systems operating (i.e. lights, rear defogger, A/C, etc.) Fuel pressure gauge may indicate false readings due to varying engine load and changes in manifold vacuum.

1. Release fuel pressure to zero. Refer to "FUEL PRESSURE RELEASE".

2. Prepare fuel hose for fuel pressure check B and fuel tube adapter (KV10118400) D, then connect fuel pressure gauge A.

- ⇐: To quick connector
- ←: To fuel tube (engine side)
- C: Clamp
- Use suitable fuel hose for fuel pressure check (genuine NISSAN fuel hose without quick connector).
- To avoid unnecessary force or tension to hose, use moderately long fuel hose for fuel pressure check.
- Do not use the fuel hose for checking fuel pressure with damage or cracks on it.
- Use Pressure Gauge to check fuel pressure.

3. Remove fuel hose. Refer to [EM-35, "Removal and Installation"](#).
 - Do not twist or kink fuel hose because it is plastic hose.

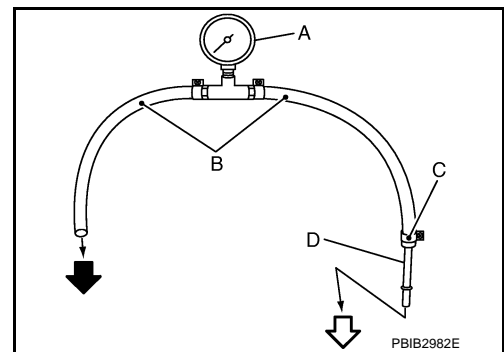

FUEL PRESSURE

[MR18DE]

< PERIODIC MAINTENANCE >

4. Connect fuel hose for fuel pressure check (1) to fuel tube (engine side) with clamp (2) as shown in the figure.
 - No.2 spool (5)
 - Wipe off oil or dirt from hose insertion part using cloth moistened with gasoline.
 - Apply proper amount of gasoline between top of the fuel tube (3) and No.1 spool (4).
 - Insert fuel hose for fuel pressure check until it touches the No.1 spool on fuel tube.
 - Use NISSAN genuine hose clamp (part number: 16439 N4710 or 16439 40U00).
 - When reconnecting fuel line, always use new clamps.
 - Use a torque driver to tighten clamps.
 - Install hose clamp to the position within 1 - 2 mm (0.04 - 0.08 in).

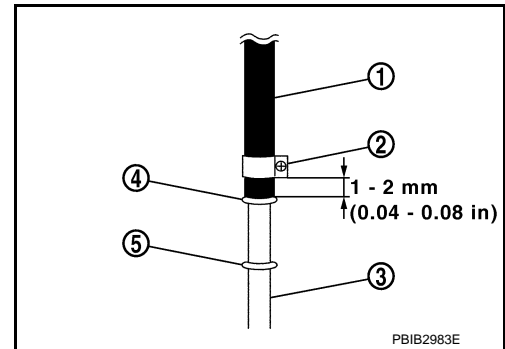

Tightening torque: 1 - 1.5 N·m (0.1 - 0.15 kg·m, 9 - 13 in·lb)

- Make sure that clamp screw does not contact adjacent parts.
5. Connect fuel tube adapter to quick connector.
 - A: Fuel pressure gauge
 - B: Fuel hose for fuel pressure check
 6. After connecting fuel hose for fuel pressure check, pull the hose with a force of approximately 98 N (10 kg, 22 lb) to confirm fuel tube does not come off.
 7. Turn ignition switch ON and check for fuel leakage.
 8. Start engine and check for fuel leakage.
 9. Read the indication of fuel pressure gauge.
 - Do not perform fuel pressure check with system operating. Fuel pressure gauge may indicate false readings.
 - During fuel pressure check, confirm for fuel leakage from fuel connection every 3 minutes.

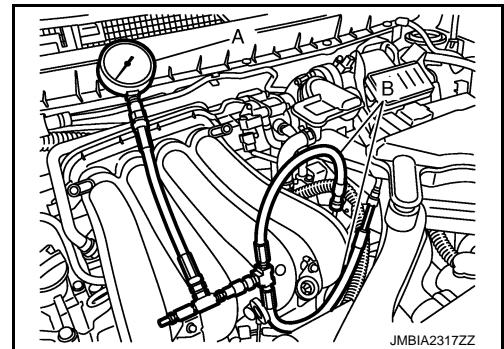

At idling: Approximately 350 kPa (3.57 kg/cm², 51 psi)

10. If result is unsatisfactory, go to next step.
11. Check the following.
 - Fuel hoses and fuel tubes for clogging
 - Fuel filter for clogging
 - Fuel pump
 - Fuel pressure regulator for cloggingIf OK, replace fuel pressure regulator.
If NG, repair or replace.
12. Before disconnecting Fuel Pressure Gauge and Fuel Pressure Adapter J-44321-6, release fuel pressure to zero. Refer to "FUEL PRESSURE RELEASE".

EVAP LEAK CHECK

< PERIODIC MAINTENANCE >

[MR18DE]

EVAP LEAK CHECK

Inspection

INFOID:000000004833562

CAUTION:

- Do not use compressed air or a high pressure pump.
- Do not exceed 4.12 kPa (0.042 kg/cm², 0.6 psi) of pressure in EVAP system.

NOTE:

- Do not start engine.
- Improper installation of EVAP service port adapter [commercial service tool: (J-41413-OBDD)] to the EVAP service port may cause a leak.

Ⓟ WITH CONSULT-III

1. Install EVAP service port adapter [commercial service tool: (J-41413-OBDD)] and pressure pump to EVAP service port.
2. Turn ignition switch ON.
3. Select the "EVAP SYSTEM CLOSE" of "WORK SUPPORT" mode with CONSULT-III.
4. Touch "START". A bar graph (Pressure indicating display) will appear on the screen.
5. Apply positive pressure to the EVAP system until the pressure indicator reaches the middle of the bar graph.
6. Remove EVAP service port adapter [commercial service tool: (J-41413-OBDD)] and hose with pressure pump.
7. Locate the leak using a leak detector [commercial service tool: (J-41416)]. Refer to [EC-68. "System Description"](#).

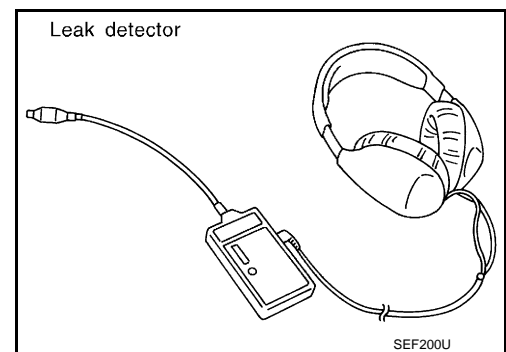
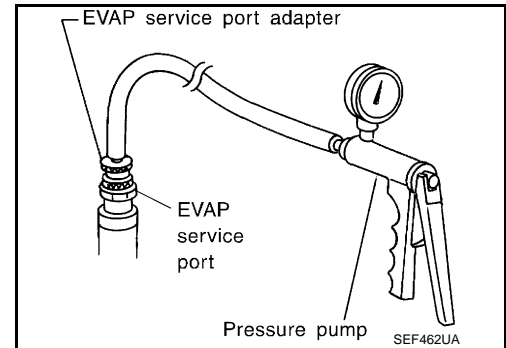

ⓧ WITHOUT CONSULT-III

1. Install EVAP service port adapter [commercial service tool: (J-41413-OBDD)] and pressure pump to EVAP service port.
2. Apply battery voltage between the terminals of EVAP canister vent control valve to make a closed EVAP system.
3. To locate the leak, deliver positive pressure to the EVAP system until pressure gauge points reach 1.38 to 2.76 kPa (0.014 to 0.028 kg/cm², 0.2 to 0.4 psi).
4. Remove EVAP service port adapter [commercial service tool: (J-41413-OBDD)] and hose with pressure pump.

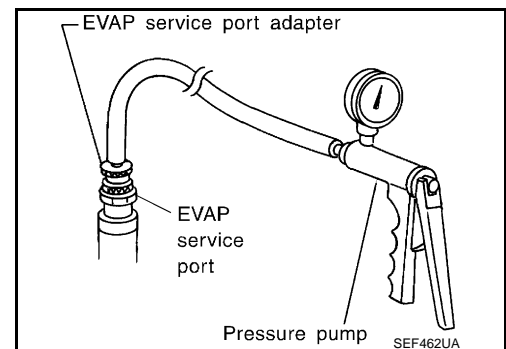

EVAP LEAK CHECK

[MR18DE]

< PERIODIC MAINTENANCE >

5. Locate the leak using a leak detector [commercial service tool: (J-41416)]. Refer to [EC-68, "System Description"](#).

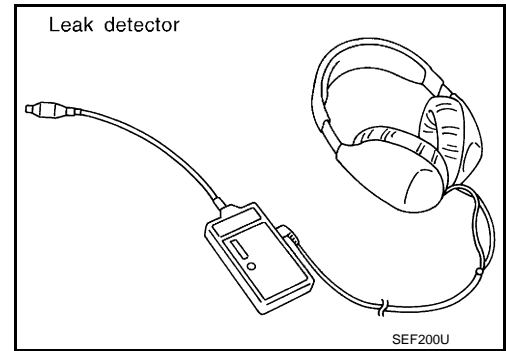

EVAP CANISTER

< REMOVAL AND INSTALLATION >

[MR18DE]

REMOVAL AND INSTALLATION

EVAP CANISTER

Exploded View

INFOID:000000004833563

A
EC

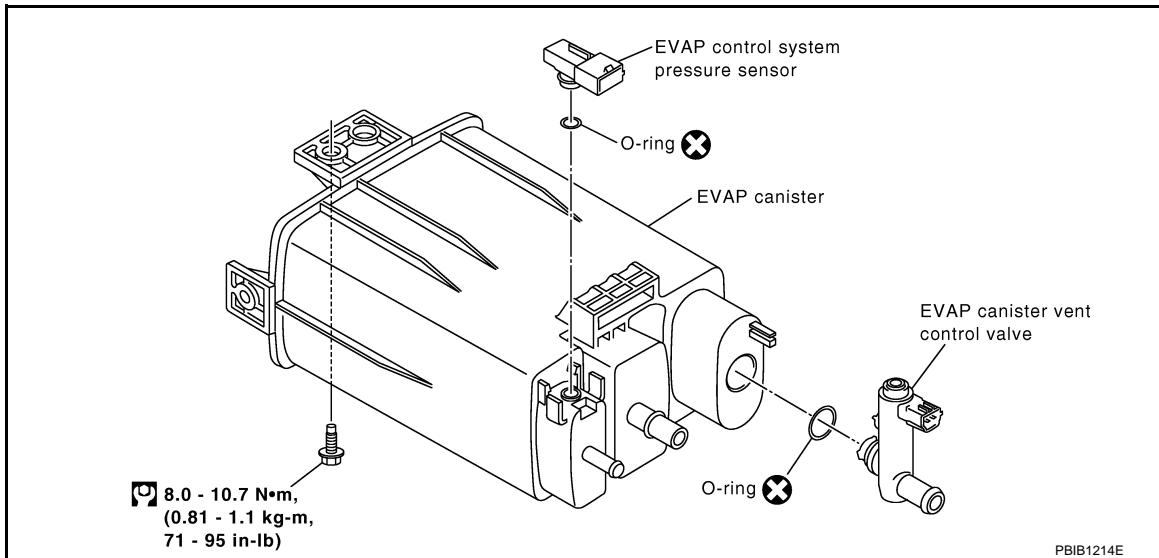

Removal and Installation

INFOID:000000004833564

REMOVAL

1. Lift up the vehicle.
2. Remove EVAP canister fixing bolt.
3. Remove EVAP canister.

NOTE:

The EVAP canister vent control valve and EVAP canister system pressure sensor can be removed without removing the EVAP canister.

INSTALLATION

Install in the reverse order of removal.

NOTE:

Tighten EVAP canister fixing bolt to the specified torque.

DISASSEMBLY

1. Turn EVAP canister vent control valve counterclockwise.
 - Lock (A)
 - Unlock (B)
2. Remove the EVAP canister vent control valve.

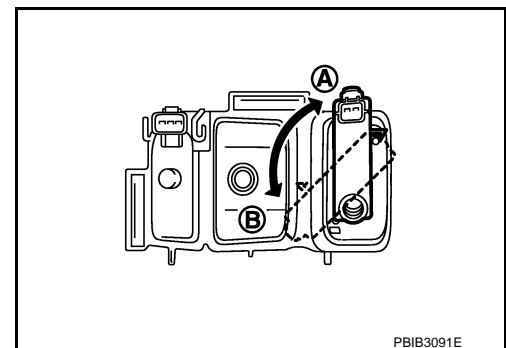

ASSEMBLY

Assemble in the reverse order of disassembly.

CAUTION:

Always replace O-ring with a new one.

C
D
E
F
G
H
I
J
K
L
M
N
O
P

EVAP CANISTER

< REMOVAL AND INSTALLATION >

[MR18DE]

INFOID:000000004833565

Inspection

Check EVAP canister as per the following:

1. Block port (B).
2. Blow air into port (A) and check that it flows freely out of port (C).
3. Release blocked port (B).
4. Apply vacuum pressure to port (B) and check that vacuum pressure exists at the ports (A) and (C).
5. Block port (A) and (B).
6. Apply pressure to port (C) and check that there is no leakage.

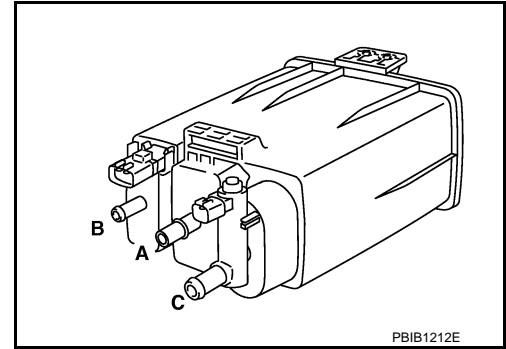

SERVICE DATA AND SPECIFICATIONS (SDS)

< SERVICE DATA AND SPECIFICATIONS (SDS)

[MR18DE]

SERVICE DATA AND SPECIFICATIONS (SDS)

SERVICE DATA AND SPECIFICATIONS (SDS)

Idle Speed

INFOID:000000004833566

EC

Transmission	Condition	Specification
CVT	No load* (in P or N position)	700 ± 50 rpm
M/T	No load* (in Neutral position)	700 ± 50 rpm

*: Under the following conditions

- A/C switch: OFF
- Electric load: OFF (Lights, heater fan & rear window defogger)
- Steering wheel: Kept in straight-ahead position

Ignition Timing

INFOID:000000004833567

Transmission	Condition	Specification
CVT	No load* (in P or N position)	13 ± 5°BTDC
M/T	No load* (in Neutral position)	13 ± 5°BTDC

*: Under the following conditions

- A/C switch: OFF
- Electric load: OFF (Lights, heater fan & rear window defogger)
- Steering wheel: Kept in straight-ahead position

Calculated Load Value

INFOID:000000004833568

Condition	Specification (Using CONSULT-III or GST)
At idle	10 – 35 %
At 2,500 rpm	10 – 35 %

Mass Air Flow Sensor

INFOID:000000004833569

Supply voltage	Battery voltage (11 – 14 V)
Output voltage at idle	0.9 – 1.3V*
Mass air flow (Using CONSULT-III or GST)	1.0 – 4.0 g-m/sec at idle* 2.0 – 10.0 g-m/sec at 2,500 rpm*

*: Engine is warmed up to normal operating temperature and running under no load.