

A
B
C

EXL

SECTION EXL

EXTERIOR LIGHTING SYSTEM

D
E

CONTENTS

<p>BASIC INSPECTION 5</p> <p>DIAGNOSIS AND REPAIR WORKFLOW 5</p> <p style="padding-left: 20px;">Work Flow5</p> <p>SYSTEM DESCRIPTION 7</p> <p>HEADLAMP SYSTEM 7</p> <p style="padding-left: 20px;">System Diagram7</p> <p style="padding-left: 20px;">System Description7</p> <p style="padding-left: 20px;">Component Parts Location8</p> <p style="padding-left: 20px;">Component Description8</p> <p>DAYTIME RUNNING LIGHT SYSTEM 9</p> <p style="padding-left: 20px;">System Diagram9</p> <p style="padding-left: 20px;">System Description9</p> <p style="padding-left: 20px;">Component Parts Location10</p> <p style="padding-left: 20px;">Component Description10</p> <p>AUTO LIGHT SYSTEM11</p> <p style="padding-left: 20px;">System Diagram11</p> <p style="padding-left: 20px;">System Description11</p> <p style="padding-left: 20px;">Component Parts Location13</p> <p style="padding-left: 20px;">Component Description13</p> <p>FRONT FOG LAMP SYSTEM14</p> <p style="padding-left: 20px;">System Diagram14</p> <p style="padding-left: 20px;">System Description14</p> <p style="padding-left: 20px;">Component Parts Location14</p> <p style="padding-left: 20px;">Component Description15</p> <p>TURN SIGNAL AND HAZARD WARNING LAMP SYSTEM16</p> <p style="padding-left: 20px;">System Diagram16</p> <p style="padding-left: 20px;">System Description16</p> <p style="padding-left: 20px;">Component Parts Location17</p> <p style="padding-left: 20px;">Component Description17</p> <p>PARKING, LICENSE PLATE, SIDE MARKER AND TAIL LAMPS SYSTEM18</p> <p style="padding-left: 20px;">System Diagram18</p> <p style="padding-left: 20px;">System Description18</p>	<p style="padding-left: 20px;">Component Parts Location19</p> <p style="padding-left: 20px;">Component Description19</p> <p>EXTERIOR LAMP BATTERY SAVER SYSTEM20</p> <p style="padding-left: 20px;">System Diagram20</p> <p style="padding-left: 20px;">System Description20</p> <p style="padding-left: 20px;">Component Parts Location21</p> <p style="padding-left: 20px;">Component Description21</p> <p>DIAGNOSIS SYSTEM (BCM) (WITH INTELLIGENT KEY SYSTEM)22</p> <p>COMMON ITEM22</p> <p style="padding-left: 20px;">COMMON ITEM : CONSULT-III Function (BCM - COMMON ITEM)22</p> <p>HEADLAMP23</p> <p style="padding-left: 20px;">HEADLAMP : CONSULT-III Function (BCM - HEAD LAMP)23</p> <p>FLASHER26</p> <p style="padding-left: 20px;">FLASHER : CONSULT-III Function (BCM - FLASHER)26</p> <p>DIAGNOSIS SYSTEM (BCM) (WITHOUT INTELLIGENT KEY SYSTEM)28</p> <p>COMMON ITEM28</p> <p style="padding-left: 20px;">COMMON ITEM : CONSULT-III Function (BCM - COMMON ITEM)28</p> <p>HEADLAMP28</p> <p style="padding-left: 20px;">HEADLAMP : CONSULT-III Function (BCM - HEAD LAMP)29</p> <p>FLASHER31</p> <p style="padding-left: 20px;">FLASHER : CONSULT-III Function (BCM - FLASHER)31</p> <p>DIAGNOSIS SYSTEM (IPDM E/R) (WITH INTELLIGENT KEY SYSTEM)32</p> <p style="padding-left: 20px;">Diagnosis Description32</p>
--	--

EXL

P

CONSULT-III Function (IPDM E/R)	34	DAYTIME RUNNING LIGHT RELAY CIRCUIT	... 57
DIAGNOSIS SYSTEM (IPDM E/R) (WITHOUT INTELLIGENT KEY SYSTEM)	37	Component Function Check	57
Diagnosis Description	37	Diagnosis Procedure	57
CONSULT-III Function (IPDM E/R)	39	Component Inspection (Daytime Running Light Relay-1)	58
DTC/CIRCUIT DIAGNOSIS	41	Component Inspection (Daytime Running Light Relay-2)	59
POWER SUPPLY AND GROUND CIRCUIT	41	PARKING LAMP CIRCUIT	60
BCM (BODY CONTROL SYSTEM) (WITH INTELLIGENT KEY SYSTEM)	41	Component Function Check	60
BCM (BODY CONTROL SYSTEM) (WITH INTELLIGENT KEY SYSTEM) : Diagnosis Procedure	41	Diagnosis Procedure	60
BCM (BODY CONTROL SYSTEM) (WITHOUT INTELLIGENT KEY SYSTEM)	41	TURN SIGNAL LAMP CIRCUIT	62
BCM (BODY CONTROL SYSTEM) (WITHOUT INTELLIGENT KEY SYSTEM) : Diagnosis Procedure	41	Description	62
IPDM E/R (WITH INTELLIGENT KEY SYSTEM)	42	Component Function Check	62
IPDM E/R (WITH INTELLIGENT KEY SYSTEM) : Diagnosis Procedure	42	Diagnosis Procedure	62
IPDM E/R (WITHOUT INTELLIGENT KEY SYSTEM)	43	OPTICAL SENSOR	64
IPDM E/R (WITHOUT INTELLIGENT KEY SYSTEM) : Diagnosis Procedure	43	Description	64
EXTERIOR LAMP FUSE	45	Component Function Check	64
WITHOUT DAYTIME RUNNING LIGHT SYSTEM ...	45	Diagnosis Procedure	64
WITHOUT DAYTIME RUNNING LIGHT SYSTEM : Description	45	HAZARD SWITCH	67
WITHOUT DAYTIME RUNNING LIGHT SYSTEM : Diagnosis Procedure	45	Component Function Check	67
WITH DAYTIME RUNNING LIGHT SYSTEM	45	Diagnosis Procedure	67
WITH DAYTIME RUNNING LIGHT SYSTEM : Description	45	TAIL LAMP CIRCUIT	69
WITH DAYTIME RUNNING LIGHT SYSTEM : Diagnosis Procedure	46	Component Function Check	69
HEADLAMP (HI) CIRCUIT	47	Diagnosis Procedure	69
Component Function Check	47	REAR SIDE MARKER LAMP CIRCUIT	71
Diagnosis Procedure	47	Component Function Check	71
HEADLAMP (LO) CIRCUIT	50	Diagnosis Procedure	71
Component Function Check	50	LICENSE PLATE LAMP CIRCUIT	72
WITH DAYTIME RUNNING LIGHT SYSTEM	50	Component Function Check	72
WITH DAYTIME RUNNING LIGHT SYSTEM : Diagnosis Procedure	50	Diagnosis Procedure	72
WITHOUT DAYTIME RUNNING LIGHT SYSTEM ...	53	HEADLAMP SYSTEM	73
WITHOUT DAYTIME RUNNING LIGHT SYSTEM : Diagnosis Procedure	53	Wiring Diagram - HEADLAMP -	73
FRONT FOG LAMP CIRCUIT	55	AUTO LIGHT SYSTEM	77
Component Function Check	55	Wiring Diagram - AUTO LIGHT SYSTEM -	77
Diagnosis Procedure	55	DAYTIME RUNNING LIGHT SYSTEM	83
		Wiring Diagram - DAYTIME RUNNING LIGHT SYSTEM -	83
		FRONT FOG LAMP SYSTEM	90
		Wiring Diagram - FRONT FOG LAMP -	90
		TURN SIGNAL AND HAZARD WARNING LAMP SYSTEM	93
		Wiring Diagram - TURN AND HAZARD WARNING LAMPS -	93
		PARKING, LICENSE PLATE, SIDE MARKER AND TAIL LAMPS SYSTEM	97
		Wiring Diagram - PARKING, LICENSE PLATE, SIDE MARKER AND TAIL LAMPS -	97

STOP LAMP	103	Description	195	
Wiring Diagram - STOP LAMP -	103	Diagnosis Procedure	195	A
BACK-UP LAMP	106	BOTH SIDE HEADLAMPS (LO) ARE NOT		
Wiring Diagram - BACK-UP LAMP -	106	TURNED ON	196	B
ECU DIAGNOSIS INFORMATION	109	Description	196	
BCM (BODY CONTROL MODULE)	109	Diagnosis Procedure	196	
WITH INTELLIGENT KEY	109	PARKING, LICENSE PLATE, SIDE MARKER		
WITH INTELLIGENT KEY : Reference Value	109	AND TAIL LAMPS ARE NOT TURNED ON ...	197	C
WITH INTELLIGENT KEY : Wiring Diagram -		Description	197	
BCM -	130	Diagnosis Procedure	197	D
WITH INTELLIGENT KEY : Fail-safe	134	BOTH SIDE FRONT FOG LAMPS ARE NOT		
WITH INTELLIGENT KEY :		TURNED ON	198	E
DTC Inspection Priority Chart	136	Description	198	
WITH INTELLIGENT KEY : DTC Index	138	Diagnosis Procedure	198	
WITHOUT INTELLIGENT KEY	140	PRECAUTION	199	F
WITHOUT INTELLIGENT KEY : Reference Value.	140	PRECAUTIONS	199	
WITHOUT INTELLIGENT KEY : Wiring Diagram -		Precaution for Supplemental Restraint System		
BCM -	156	(SRS) "AIR BAG" and "SEAT BELT PRE-TEN-		G
WITHOUT INTELLIGENT KEY : Fail-safe	159	SIONER"	199	
WITHOUT INTELLIGENT KEY :		PERIODIC MAINTENANCE	200	H
DTC Inspection Priority Chart	160	HEADLAMP AIMING ADJUSTMENT	200	
WITHOUT INTELLIGENT KEY : DTC Index	161	Description	200	
IPDM E/R (INTELLIGENT POWER DISTRI-		Aiming Adjustment Procedure	201	I
BUTION MODULE ENGINE ROOM)	163	FRONT FOG LAMP AIMING ADJUSTMENT .	203	
WITH INTELLIGENT KEY	163	Description	203	J
WITH INTELLIGENT KEY : Reference Value	163	Aiming Adjustment Procedure	203	
WITH INTELLIGENT KEY : Wiring Diagram —		REMOVAL AND INSTALLATION	205	K
IPDM E/R —	170	FRONT COMBINATION LAMP	205	
WITH INTELLIGENT KEY : Fail-Safe	174	Exploded View	205	
WITH INTELLIGENT KEY : DTC Index	176	Removal and Installation	205	
WITHOUT INTELLIGENT KEY	176	Replacement	206	
WITHOUT INTELLIGENT KEY : Reference Value.	176	Disassembly and Assembly	206	
WITHOUT INTELLIGENT KEY : Wiring Diagram		FRONT FOG LAMP	208	M
— IPDM E/R —	183	Exploded View	208	
WITHOUT INTELLIGENT KEY : Fail-Safe	186	Removal and Installation	208	
WITHOUT INTELLIGENT KEY : DTC Index	188	Replacement	208	N
SYMPTOM DIAGNOSIS	189	OPTICAL SENSOR	210	
EXTERIOR LIGHTING SYSTEM SYMPTOMS.	189	Exploded View	210	
WITHOUT DAYTIME RUNNING LIGHT SYSTEM..	189	Removal and Installation	210	O
WITHOUT DAYTIME RUNNING LIGHT SYSTEM		Replacement	210	
: Symptom Table	189	LIGHTING & TURN SIGNAL SWITCH	211	
WITH DAYTIME RUNNING LIGHT SYSTEM	190	Exploded View	211	P
WITH DAYTIME RUNNING LIGHT SYSTEM :		SIDE TURN SIGNAL LAMP	212	
Symptom Table	190	Exploded View	212	
NORMAL OPERATING CONDITION	194	Removal and Installation	212	
Description	194	Replacement	212	
BOTH SIDE HEADLAMPS (HI) ARE NOT		HAZARD SWITCH	214	
TURNED ON	195	Exploded View	214	

EXL

Removal and Installation	214	Replacement	219
REAR COMBINATION LAMP	215	LICENSE PLATE LAMP	221
Exploded View	215	Exploded View	221
Removal and Installation	215	Removal and Installation	221
Replacement	216	Replacement	221
REAR SIDE MARKER LAMP	218	SERVICE DATA AND SPECIFICATIONS	
Exploded View	218	(SDS)	223
Removal and Installation	218	SERVICE DATA AND SPECIFICATIONS	
Replacement	218	(SDS)	223
HIGH-MOUNTED STOP LAMP	219	Bulb Specifications	223
Exploded View	219		
Removal and Installation	219		

DIAGNOSIS AND REPAIR WORKFLOW

< BASIC INSPECTION >

BASIC INSPECTION

DIAGNOSIS AND REPAIR WORKFLOW

Work Flow

INFOID:000000004991922

OVERALL SEQUENCE

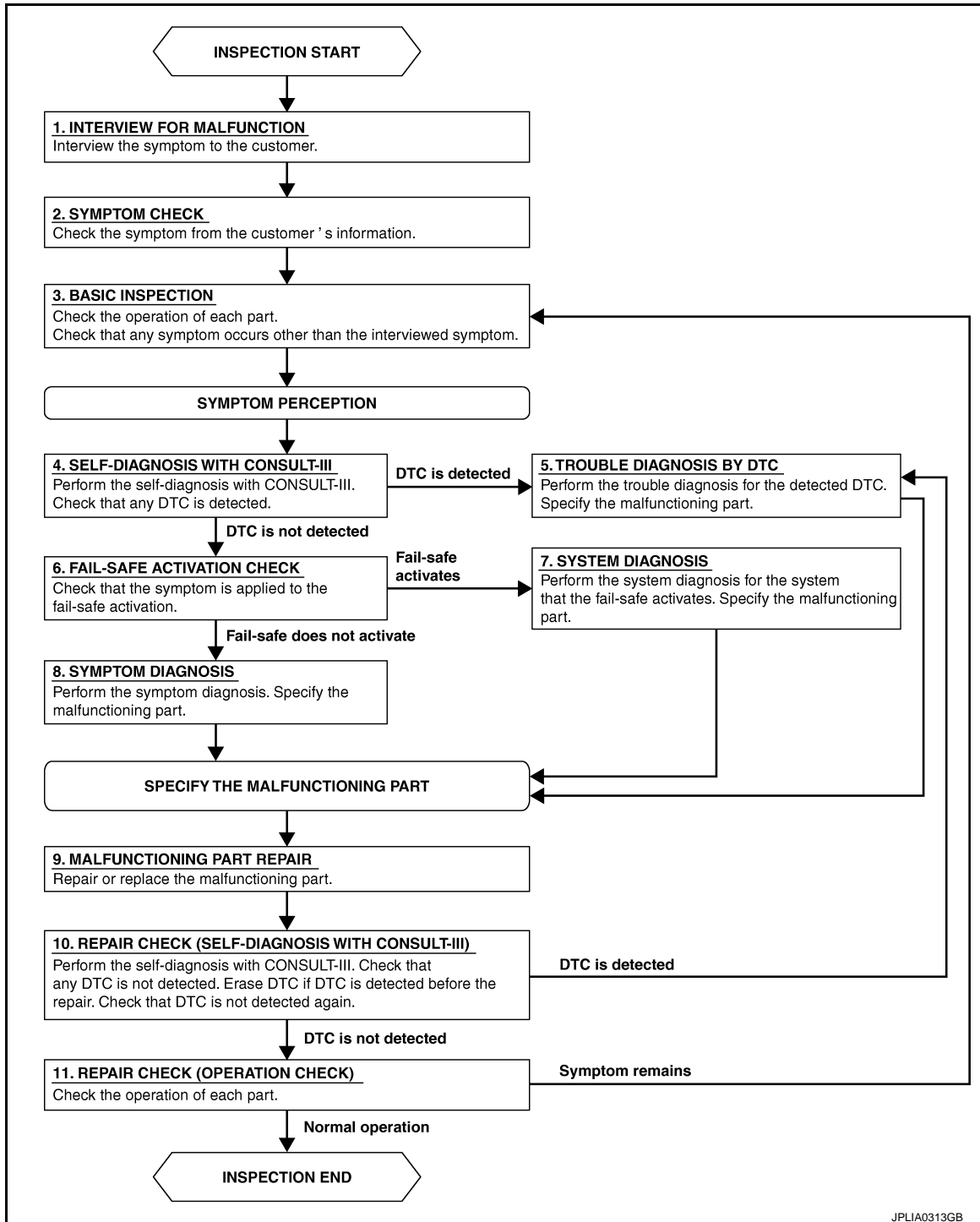

DETAILED FLOW

1. INTERVIEW FOR MALFUNCTION

Interview the symptom to the customer.

DIAGNOSIS AND REPAIR WORKFLOW

< BASIC INSPECTION >

>> GO TO 2.

2. SYMPTOM CHECK

Check the symptom from the customer's information.

>> GO TO 3.

3. BASIC INSPECTION

Check the operation of each part. Check that any symptom occurs other than the interviewed symptom.

>> GO TO 4.

4. SELF-DIAGNOSIS WITH CONSULT-III

Perform the self-diagnosis with CONSULT-III. Check that any DTC is detected.

Is any DTC detected?

YES >> GO TO 5.

NO >> GO TO 6.

5. TROUBLE DIAGNOSIS BY DTC

Perform the trouble diagnosis for the detected DTC. Specify the malfunctioning part.

>> GO TO 9.

6. FAIL-SAFE ACTIVATION CHECK

Check that the symptom is applied to the fail-safe activation.

Does the fail-safe activate?

YES >> GO TO 7.

NO >> GO TO 8.

7. SYSTEM DIAGNOSIS

Perform the system diagnosis for the system that the fail-safe activates. Specify the malfunctioning part.

>> GO TO 9.

8. SYMPTOM DIAGNOSIS

Perform the symptom diagnosis. Specify the malfunctioning part.

>> GO TO 9.

9. MALFUNCTION PART REPAIR

Repair or replace the malfunctioning part.

>> GO TO 10.

10. REPAIR CHECK (SELF-DIAGNOSIS WITH CONSULT-III)

Perform the self-diagnosis with CONSULT-III. Check that any DTC is not detected. Erase DTC if DTC is detected before the repair. Check that DTC is not detected again.

Is any DTC detected?

YES >> GO TO 5.

NO >> GO TO 11.

11. REPAIR CHECK (OPERATION CHECK)

Check the operation of each part.

Does it operate normally?

YES >> INSPECTION END

NO >> GO TO 3.

HEADLAMP SYSTEM

< SYSTEM DESCRIPTION >

SYSTEM DESCRIPTION

HEADLAMP SYSTEM

System Diagram

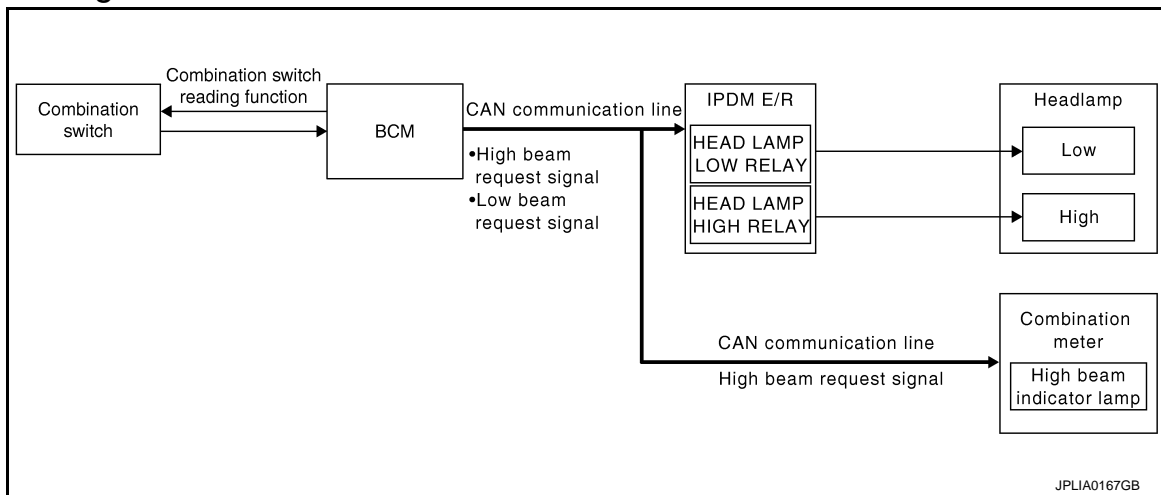

System Description

INFOID:000000004991924

OUTLINE

Headlamp is controlled by combination switch reading function and headlamp control function of BCM, and relay control function of IPDM E/R.

HEADLAMP (LO) OPERATION

- BCM detects the combination switch condition with the combination switch reading function.
- BCM transmits the low beam request signal to IPDM E/R with CAN communication according to the headlamp (LO) ON condition.

Headlamp (LO) ON condition

- Lighting switch 2ND
- Lighting switch AUTO, and the auto light function ON judgment (With auto light system)
- IPDM E/R turns the integrated headlamp low relay ON, and turns the headlamp ON according to the low beam request signal.

NOTE:

Daytime running light model goes through the daytime running light relay-2 in headlamp low (RH) circuit. For details, refer to [EXL-9. "System Description"](#).

HEADLAMP (HI) OPERATION

- BCM transmits the high beam request signal to IPDM E/R and the combination meter with CAN communication according to the headlamp (HI) ON condition.

Headlamp (HI) ON condition

- Lighting switch HI with the lighting switch 2ND or AUTO (auto light function ON judgment)
- Lighting switch PASS
- Combination meter turns the high beam indicator lamp ON according to the high beam request signal.
- IPDM E/R turns the integrated headlamp high relay ON, and turns the headlamp ON according to the high beam request signal.

HEADLAMP SYSTEM

< SYSTEM DESCRIPTION >

Component Parts Location

INFOID:000000004991925

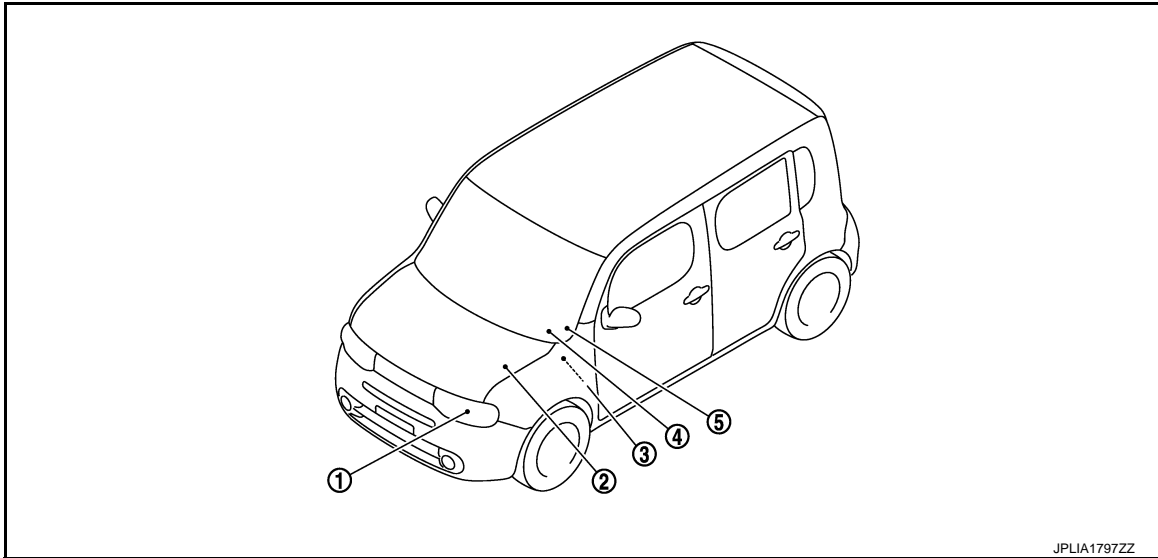

- | | | |
|--|---|--|
| 1. Headlamp | 2. IPDM E/R
Refer to PCS-6, "Component Parts Location" . | 3. BCM
Refer to BCS-9, "Component Parts Location" . |
| 4. Combination meter
(High beam indicator lamp) | 5. Combination switch | |

Component Description

INFOID:000000004991926

Part	Description
BCM	<ul style="list-style-type: none"> • Detects each switch condition by the combination switch reading function. • Judges that the headlamp is turned ON according to the vehicle condition. - Requests the headlamp relay (HI/LO) ON to IPDM E/R (with CAN communication). - Requests the high beam indicator lamp ON to the combination meter (with CAN communication).
IPDM E/R	Controls the integrated relay, and supplies voltage to the load according to the request from BCM (with CAN communication).
Combination switch (Lighting & turn signal switch)	Refer to BCS-10, "System Diagram" .
Combination meter (High beam indicator lamp)	Turns the high beam indicator lamp ON according to the request from BCM (with CAN communication).

DAYTIME RUNNING LIGHT SYSTEM

< SYSTEM DESCRIPTION >

DAYTIME RUNNING LIGHT SYSTEM

System Diagram

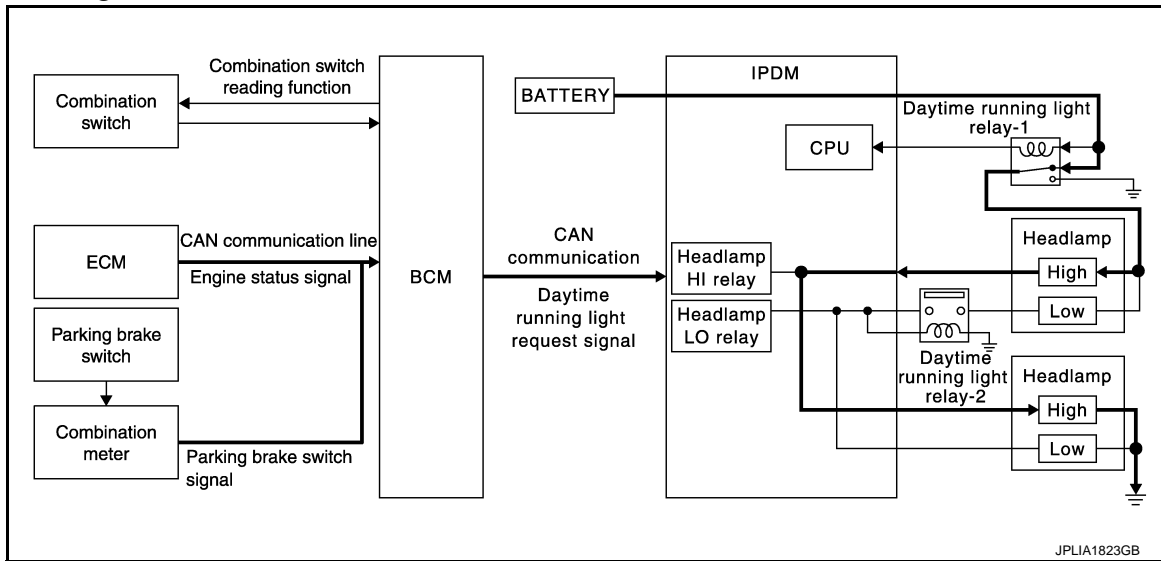

System Description

INFOID:000000004992187

OUTLINE

- Turns the headlamp high ON (high beam at approximately half illumination) as the daytime running light.
- Daytime running light is controlled by daytime running light control function and combination switch reading function of BCM, and relay control function of IPDM E/R.

DAYTIME RUNNING LIGHT OPERATION

- BCM detects the combination switch condition by the combination switch reading function.
- BCM detects the engine condition by the engine status signal received from ECM with CAN communication.
- BCM detects the parking brake condition by the parking brake switch signal received from combination meter with CAN communication.
- BCM transmits the daytime running light request signal to IPDM E/R with CAN communication according to the daytime running light ON condition.

Daytime running light ON condition

- Engine running
- Lighting switch OFF or 1ST
- Parking brake switch OFF
- IPDM E/R controls the daytime running light relay-1 (ground-side) to turn ON according to the daytime running light request signal.
- Power is supplied from the daytime running light relay-1 through headlamp high (RH) and IPDM E/R to headlamp high (LH). And high beam headlamps are illuminated (approximately half illumination) as the daytime running light.

NOTE:

- Daytime running light relay-2 is turned ON when headlamp is low.
- Daytime running light relay-2 is OFF to cut voltage of headlamp low circuit when daytime running light is ON.

A
B
C
D
E
F
G
H
I
J
K
EXL
M
N
O
P

DAYTIME RUNNING LIGHT SYSTEM

< SYSTEM DESCRIPTION >

Component Parts Location

INFOID:000000004992188

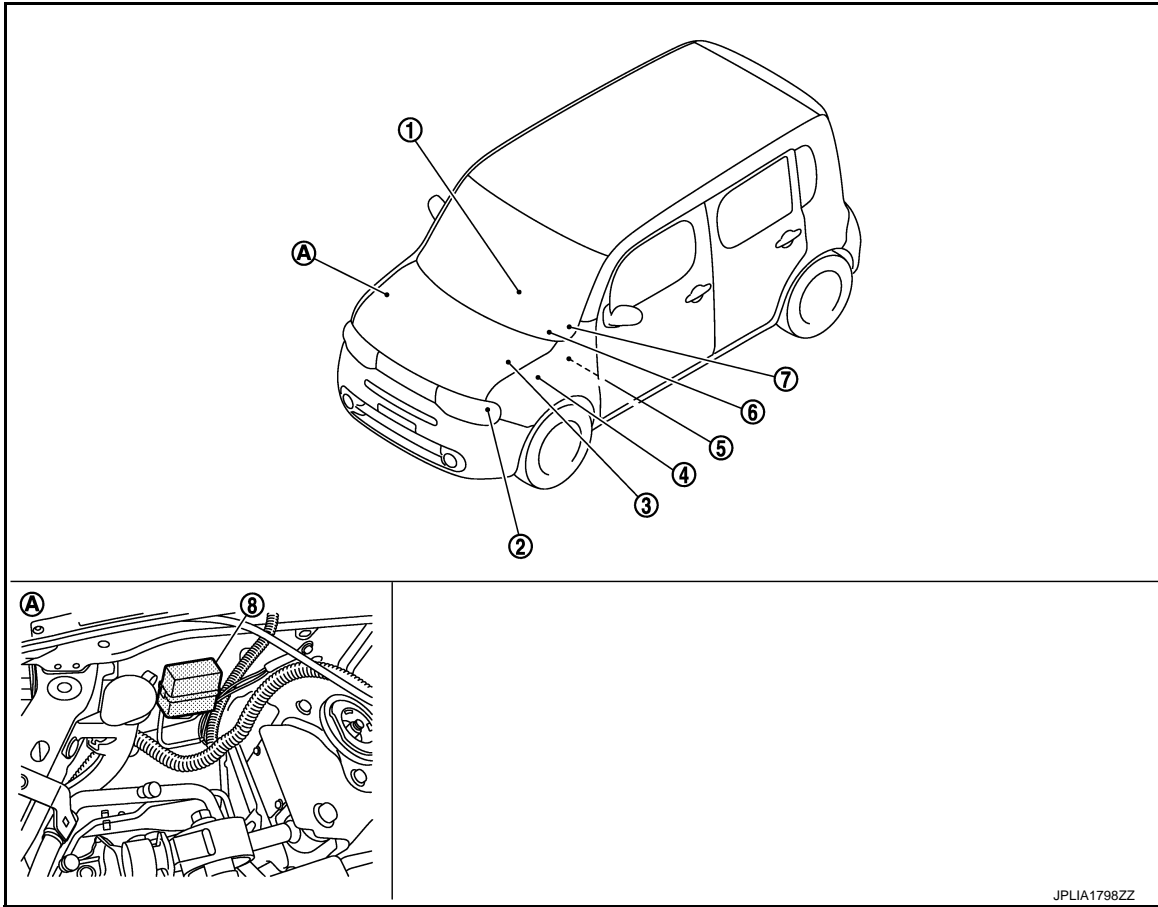

- | | | |
|--|--|---|
| 1. Parking brake switch | 2. Daytime running light (Headlamp HI) | 3. IPDM E/R
Refer to PCS-6, "Component Parts Location" . |
| 4. ECM
Refer to EC-22, "Component Parts Location" . | 5. BCM
Refer to BCS-9, "Component Parts Location" . | 6. Combination meter |
| 7. Combination switch | 8. • Daytime running light relay-1
• Daytime running light relay-2 | |
| A. Engine room (RH) | | |

Component Description

INFOID:000000004992189

Part	Description
BCM	<ul style="list-style-type: none"> • Detects each switch condition with the combination switch reading function. • Judges each lamps ON/OFF condition according to the vehicle condition. - Requests the each relay ON to IPDM E/R (with CAN communication).
IPDM E/R	Controls the relay and supplies voltage to the load according to the request from BCM (with CAN communication).
Daytime running light relay-1	Switches headlamp (HI) circuit to illuminate the daytime running light.
Daytime running light relay-2	Cuts voltage of headlamp low circuit when daytime running light is ON.
Combination switch (Lighting & turn signal switch)	Refer to BCS-10, "System Diagram" .
ECM	Transmits the engine status signal to BCM (with CAN communication).
Combination meter	Transmits the parking brake switch signal to BCM (with CAN communication).

AUTO LIGHT SYSTEM

< SYSTEM DESCRIPTION >

AUTO LIGHT SYSTEM

System Diagram

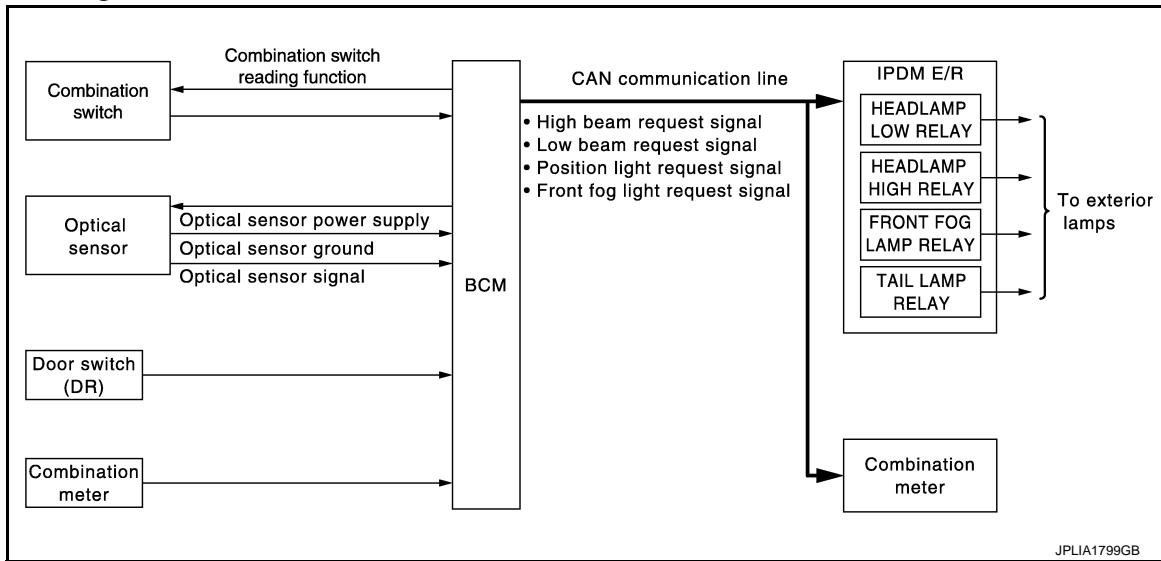

System Description

INFOID:000000004992193

OUTLINE

- Auto light system is controlled by each function of BCM and IPDM E/R.

Control by BCM

- Combination switch reading function
- Headlamp control function
- Auto light function
- Delay timer function
- Wiper linked auto lighting function

Control by IPDM E/R

- Relay control function

- Auto light system has the auto light function (with twilight lighting function^{*1}), wiper linked auto lighting function and delay timer function.

*1:For USA only

- Auto light function automatically turns ON/OFF the exterior lamps^{*2} and each illumination automatically, depending on the outside brightness.
- Wiper linked auto lighting function automatically turns ON/OFF the exterior lamps* and each illumination when the light switch is in the AUTO position, according to a front wiper operation.
- When auto light system turns the exterior lamps ON with the ignition switch OFF, delay timer function turns the exterior lamps OFF, depending on the vehicle condition with the auto light function after a certain period of time.

*2: Headlamp (LO/HI), parking lamp (illuminated as front side marker lamps too), tail lamp, rear side marker lamp and front fog lamp (Headlamp HI and front fog lamp depend on the combination switch condition.)

NOTE:

The settings of the twilight lighting function and the wiper linked auto lighting function can be changed with CONSULT-III. Refer to [EXL-23, "HEADLAMP : CONSULT-III Function \(BCM - HEAD LAMP\)"](#).

AUTO LIGHT FUNCTION (WITH TWILIGHT LIGHTING FUNCTION)

Description

- BCM detects the combination switch condition with the combination switch reading function.
- BCM supplies voltage to the optical sensor when the ignition switch is turned ON or ACC.
- Optical sensor converts outside brightness (lux) to voltage and transmits the optical sensor signal to BCM.
- BCM detects outside brightness from the optical sensor signal and judges ON/OFF condition of the exterior lamp and each illumination, depending on the outside brightness condition (standard or twilight).

AUTO LIGHT SYSTEM

< SYSTEM DESCRIPTION >

- BCM transmits each request signal to IPDM E/R via CAN communication, according to ON/OFF condition by the auto light function.

NOTE:

As to ON/OFF timing, the sensitivity depends on settings. The settings can be changed with CONSULT-III. Refer to [EXL-23, "HEADLAMP : CONSULT-III Function \(BCM - HEAD LAMP\)"](#).

Auto Lighting Timing Table

When the light switch is in AUTO position and the ignition switch is ON, the exterior lamps turns ON/OFF in the following condition.

Exterior lamps	Standard Light ON (Sudden increase/decrease in brightness)	Twilight Light ON (Gradual increase/decrease in brightness)
ON	Outside brightness is 1250 lx or less for 3 seconds or more.	Filtered brightness is 3000 lx or less
OFF	Outside brightness is 2500 lx or more for 5 seconds or more.	Filtered brightness is 5000 lx or more

Standard Light ON

BCM turns exterior lamps ON when outside brightness obtained from the optical sensor signal is 1250 lx or less for 3 seconds or more. And BCM turns exterior lamp OFF when outside brightness from the optical sensor signal is 2500 lx or more for 5 seconds or more.

Twilight Light ON (Twilight Lighting Function)

BCM detects twilight by filtered brightness.

- BCM filters outside brightness to block the impact of the rapid change in brightness, based on the optical sensor signal, and judges outside brightness.
- BCM detects changes in outside brightness, based on outside brightness obtained from the optical sensor signal and filtered brightness and judges ON/OFF of the exterior lamps.

Filtering chart

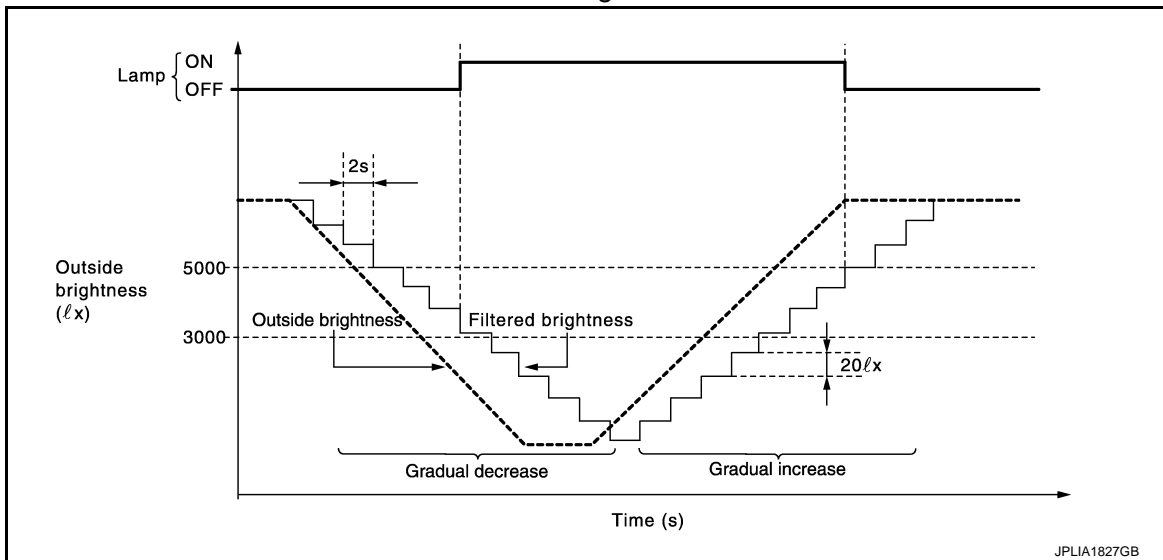

- BCM starts filtering 0.3 seconds after the ignition switch is turned ON and the light switch is turned to AUTO.
- BCM filters signals from the optical sensor at intervals of 2 seconds. When the filtered brightness is higher than outside brightness (signal from the optical sensor), BCM decreases the filtered brightness by 20 lx*. When the filtered brightness is lower than outside brightness, BCM increases the filtered brightness by 20 lx*.
- BCM turns ON the exterior lamps when filtered brightness reaches 3000 lx and turns OFF when reaching 5000 lx.

*:When vehicle speed is 5 km/h or less, BCM decreases/increases the filtered brightness by 5 lx.

WIPER LINKED AUTO LIGHTING FUNCTION

BCM turns the exterior lamp ON when detecting 4 operations of the front wiper with the light switch in AUTO position.

NOTE:

BCM turns OFF the headlamps 3 seconds after the front wiper switch is turned from HI⇒OFF.

AUTO LIGHT SYSTEM

< SYSTEM DESCRIPTION >

DELAY TIMER FUNCTION

BCM turns the exterior lamp OFF depending on the vehicle condition with the auto light function when the ignition switch is turned OFF.

- Turns the exterior lamp OFF 5 minutes after detecting that any door opens (Door switch ON).
- Turns the exterior lamp OFF a certain period of time* after closing all doors (Door switch ON→OFF).
- Turns the exterior lamp OFF with the ignition switch ACC or the light switch OFF.

*: The preset time is 45 seconds. The timer operating time can be set by CONSULT-III. Refer to [EXL-23, "HEADLAMP : CONSULT-III Function \(BCM - HEAD LAMP\)"](#).

NOTE:

When any position other than the light switch AUTO is set, the auto light system function switches to the exterior lamp battery saver function.

Component Parts Location

INFOID:000000004992194

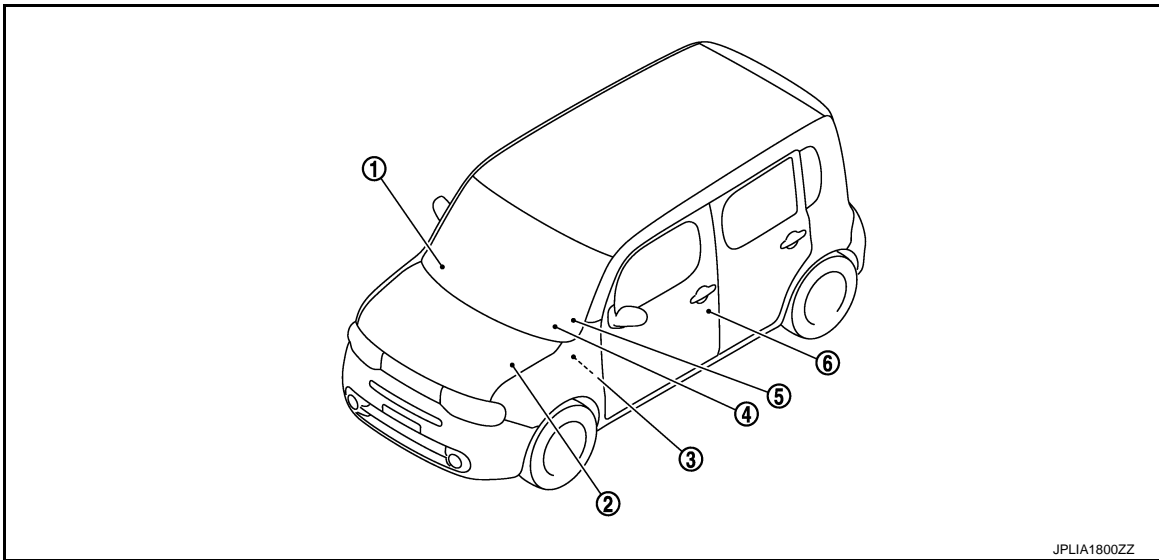

- | | | |
|----------------------|---|--|
| 1. Optical sensor | 2. IPDM E/R
Refer to PCS-6, "Component Parts Location" . | 3. BCM
Refer to BCS-9, "Component Parts Location" . |
| 4. Combination meter | 5. Combination switch | 6. Door switch |

Component Description

INFOID:000000004992195

Part	Description
BCM	<ul style="list-style-type: none"> • Detects each switch condition by the combination switch reading function. • Judges the outside brightness from the optical sensor signal. • Judges the OFF timing according to the vehicle condition. • Judges the ON/OFF status of the exterior lamp and each illumination according to the outside brightness and the vehicle condition. - Requests ON/OFF of each relay to IPDM E/R (with CAN communication).
IPDM E/R	Controls the integrated relay, and supplies voltage to the load according to the request from BCM (with CAN communication).
Combination switch (Lighting & turn signal switch)	Refer to BCS-10, "System Diagram" .
Optical sensor	Refer to EXL-64, "Description" .

FRONT FOG LAMP SYSTEM

< SYSTEM DESCRIPTION >

FRONT FOG LAMP SYSTEM

System Diagram

INFOID:000000004991935

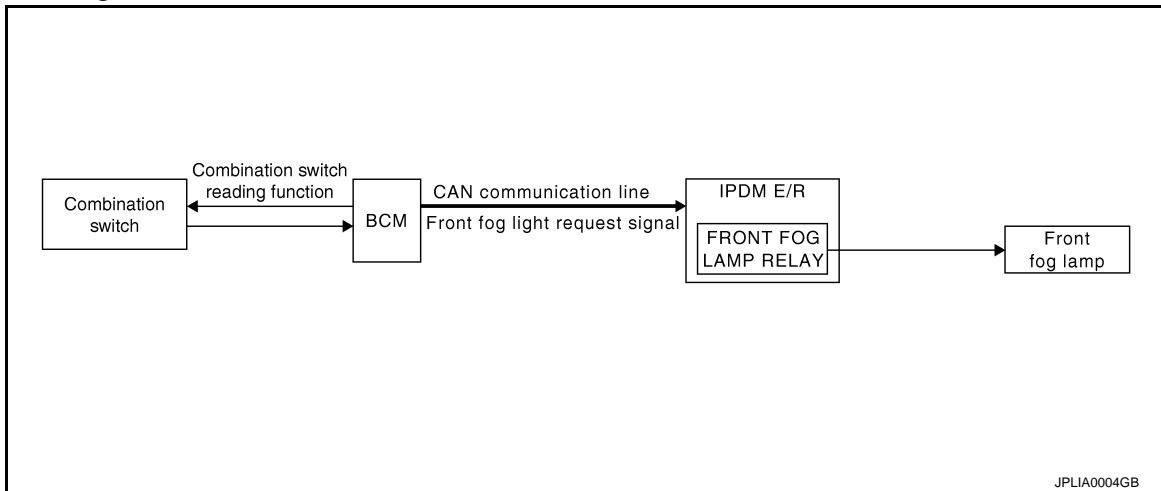

JPLIA0004GB

System Description

INFOID:000000004991936

OUTLINE

Front fog lamp is controlled by combination switch reading function and front fog lamp control function of BCM, and relay control function of IPDM E/R.

FRONT FOG LAMP OPERATION

- BCM detects the combination switch condition by the combination switch reading function.
- BCM transmits the front fog lights request signal to IPDM E/R with CAN communication according to the front fog lamp ON condition.

Front fog lamp ON condition

- Front fog lamp switch ON with headlamp ON (except for the high beam ON)
- IPDM E/R turns the integrated front fog lamp relay ON, and turns the front fog lamp ON according to the front fog lights request signal.

Component Parts Location

INFOID:000000004991937

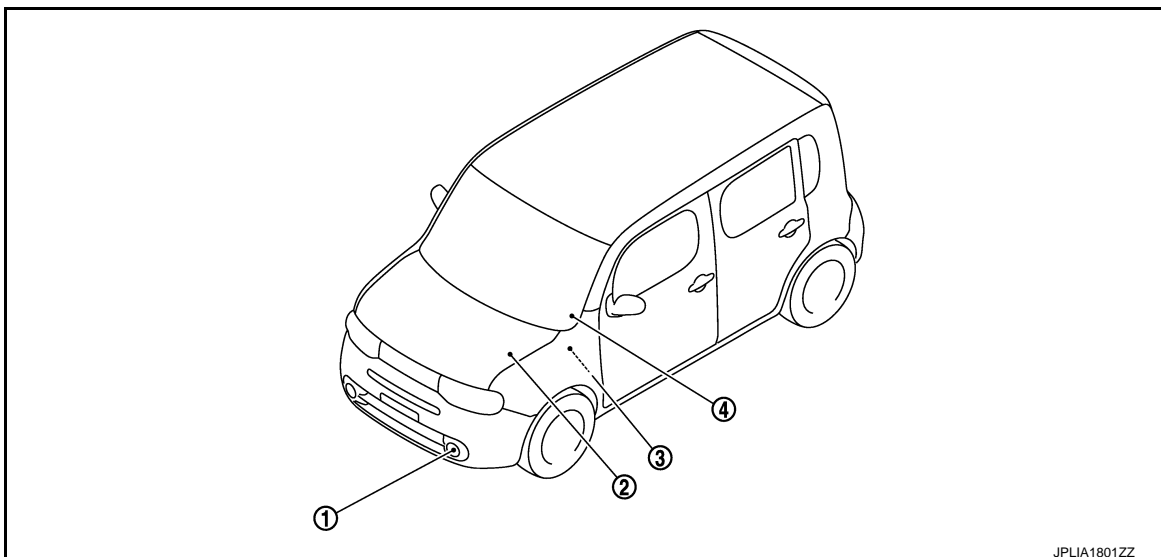

JPLIA1801ZZ

FRONT FOG LAMP SYSTEM

< SYSTEM DESCRIPTION >

- | | | |
|-----------------------|---|--|
| 1. Front fog lamp | 2. IPDM E/R
Refer to PCS-6, "Component Parts Location" . | 3. BCM
Refer to BCS-9, "Component Parts Location" . |
| 4. Combination switch | | |

Component Description

INFOID:000000004991938

Part	Description
BCM	<ul style="list-style-type: none"> • Detects each switch condition by the combination switch reading function. • Judges the front fog lamp ON/OFF status according to the vehicle condition. - Requests the front fog lamp relay ON to IPDM E/R (with CAN communication).
IPDM E/R	Controls the integrated relay and supplies voltage to the load according to the request from BCM (with CAN communication).
Combination switch (Lighting & turn signal switch)	Refer to BCS-10, "System Diagram" .

A
B
C
D
E
F
G
H
I
J
K
L
M
N
O
P

EXL

TURN SIGNAL AND HAZARD WARNING LAMP SYSTEM

< SYSTEM DESCRIPTION >

TURN SIGNAL AND HAZARD WARNING LAMP SYSTEM

System Diagram

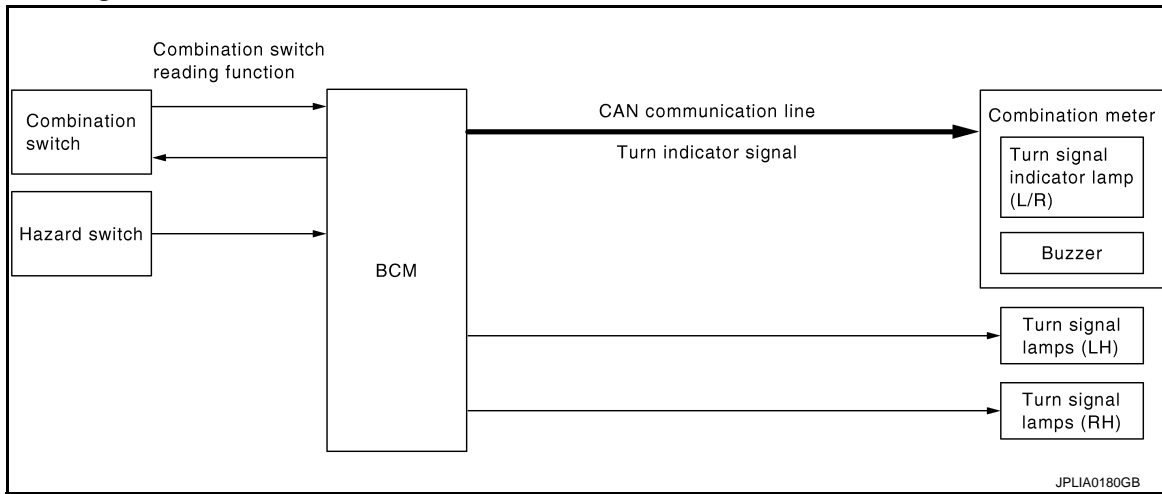

System Description

INFOID:000000004991940

OUTLINE

Turn signal lamp and the hazard warning lamp is controlled by combination switch reading function and the flasher control function of BCM.

TURN SIGNAL LAMP OPERATION

- BCM detects the combination switch condition by the combination switch reading function.
- BCM supplies voltage to the right (left) turn signal lamp circuit when the ignition switch is turned ON and the turn signal switch is in the right (left) position. BCM blinks the turn signal lamp.

HAZARD WARNING LAMP OPERATION

BCM supplies voltage to both turn signal lamp circuit when the hazard switch is turned ON. BCM blinks the hazard warning lamp.

TURN SIGNAL INDICATOR LAMP AND TURN SIGNAL OPERATION

- BCM transmits the turn signal indicator lamp signal to the combination meter with CAN communication while the turn signal lamp and the hazard warning lamp are operating.
- Combination meter outputs the turn signal sound with the integrated buzzer while blinking the turn signal indicator lamp according to the turn signal indicator lamp signal.

HIGH FLASHER OPERATION (FAIL-SAFE)

- BCM detects the turn signal lamp circuit status from the terminal voltage.
- BCM increases the turn signal lamp blinking speed if the bulb or harness open is detected with the turn signal lamp operating.

NOTE:

The blinking speed is normal while operating the hazard warning lamp.

TURN SIGNAL AND HAZARD WARNING LAMP SYSTEM

< SYSTEM DESCRIPTION >

Component Parts Location

INFOID:000000004991941

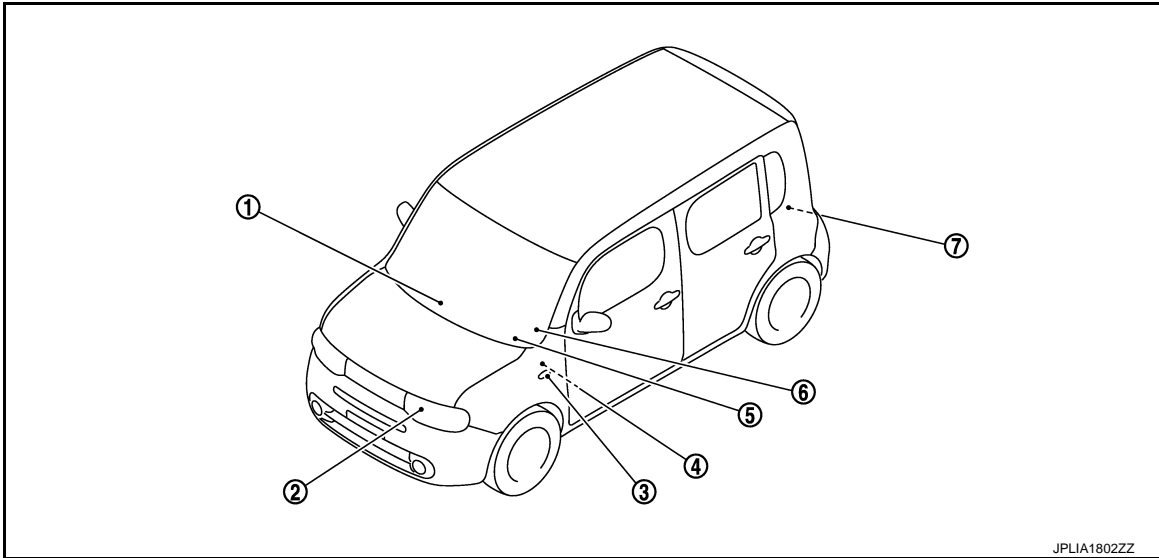

- | | | |
|--|--|--------------------------|
| 1. Hazard switch | 2. Front turn signal lamp | 3. Side turn signal lamp |
| 4. BCM
Refer to BCS-9, "Component Parts Location" . | 5. Combination meter
(Turn signal indicator lamp) | 6. Combination switch |
| 7. Rear turn signal lamp | | |

Component Description

INFOID:000000004991942

Part	Description
BCM	<ul style="list-style-type: none"> • Detects each switch condition by the combination switch reading function. • Judges the blinks of the turn signal lamp and the hazard warning lamp from each switch status. The applicable turn signal lamp blinks. • Requests the turn signal indicator lamp blink to the combination meter (with CAN communication).
Combination switch (Lighting & turn signal switch)	Refer to BCS-10, "System Diagram" .
Hazard switch	Inputs the hazard switch ON/OFF signal to BCM.
Combination meter (Turn signal indicator lamp & buzzer)	Blinks the turn signal indicator lamp and outputs the turn signal operating sound with integrated buzzer according to the request from BCM (with CAN communication).

PARKING, LICENSE PLATE, SIDE MARKER AND TAIL LAMPS SYSTEM

< SYSTEM DESCRIPTION >

PARKING, LICENSE PLATE, SIDE MARKER AND TAIL LAMPS SYSTEM

System Diagram

INFOID:000000004992196

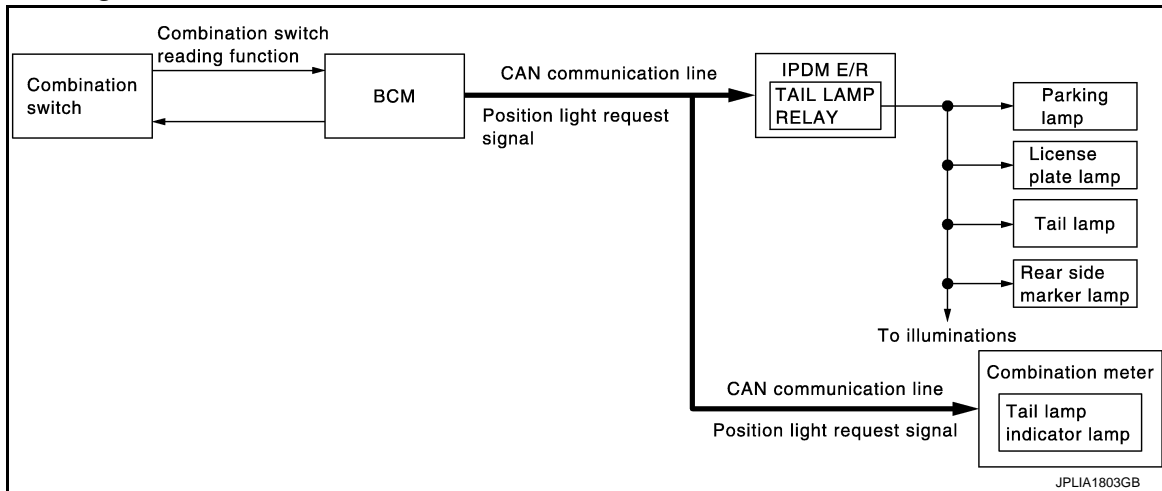

System Description

INFOID:000000004992197

OUTLINE

Parking*, license plate, tail and rear side marker lamps are controlled by combination switch reading function and headlamp control function of BCM, and relay control function of IPDM E/R.

*: Illuminated as front side marker lamps too.

PARKING, LICENSE PLATE, TAIL AND REAR SIDE MARKER LAMPS OPERATION

- BCM detects the combination switch condition by the combination switch reading function.
- BCM transmits the position light request signal to IPDM E/R and the combination meter with CAN communication according to the ON/OFF condition of the parking, license plate, tail and rear side marker lamps.

Parking, license plate, tail and rear side marker lamps ON condition

- Lighting switch 1ST
- Lighting switch 2ND
- Lighting switch AUTO, and the auto light function ON judgment (with auto light system)
- IPDM E/R turns the integrated tail lamp relay ON and turns the parking lamp, the license plate, tail and rear side marker lamps ON according to the position light request signal.
- Combination meter turns the tail lamp indicator lamp ON according to the position light request signal.

PARKING, LICENSE PLATE, SIDE MARKER AND TAIL LAMPS SYSTEM

< SYSTEM DESCRIPTION >

Component Parts Location

INFOID:000000004992198

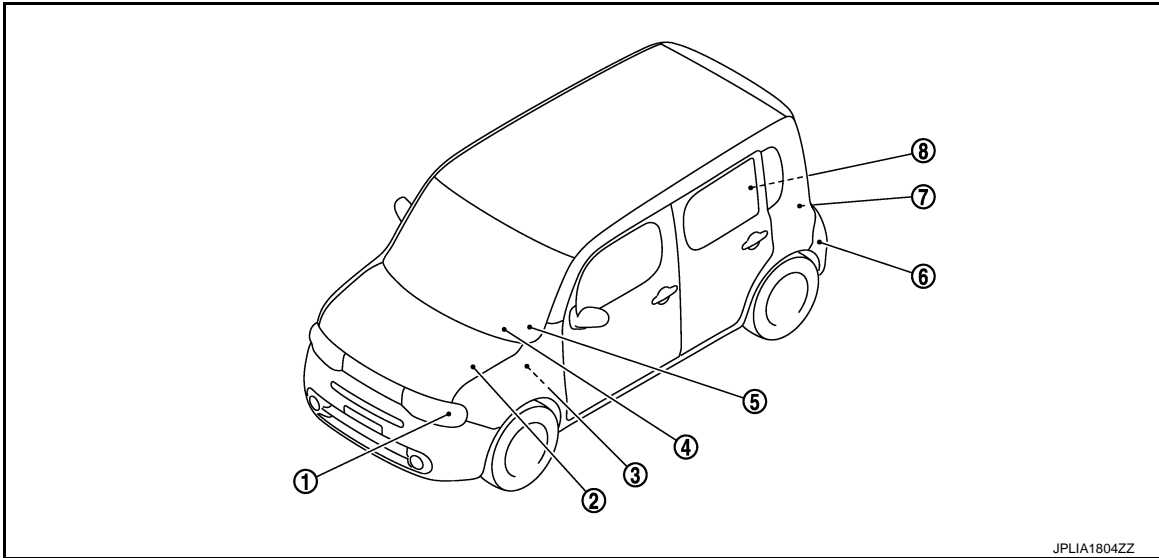

- | | | |
|--|---|--|
| 1. Parking lamp
(Front side marker lamp) | 2. IPDM E/R
Refer to PCS-6, "Component Parts Location" . | 3. BCM
Refer to BCS-9, "Component Parts Location" . |
| 4. Combination meter
(Tail lamp indicator lamp) | 5. Combination switch | 6. Rear side marker lamp |
| 7. Tail lamp | 8. License plate lamp | |

Component Description

INFOID:000000004992199

Part	Description
BCM	<ul style="list-style-type: none"> • Detects each switch condition by the combination switch reading function. • Judges the ON/OFF status of the parking, license plate, tail and rear side marker lamps according to the vehicle condition. - Requests the tail lamp relay ON to IPDM E/R (with CAN communication). - Requests the tail lamp indicator lamp ON to the combination meter (with CAN communication).
IPDM E/R	Controls the integrated relay and supplies voltage to the load according to the request from BCM (with CAN communication).
Combination switch (Lighting & turn signal switch)	Refer to BCS-10, "System Diagram" .
Combination meter (Tail lamp indicator lamp)	Turns the tail lamp indicator lamp ON according to the request from BCM (with CAN communication).

EXTERIOR LAMP BATTERY SAVER SYSTEM

< SYSTEM DESCRIPTION >

EXTERIOR LAMP BATTERY SAVER SYSTEM

System Diagram

INFOID:000000004992200

WITH INTELLIGENT KEY

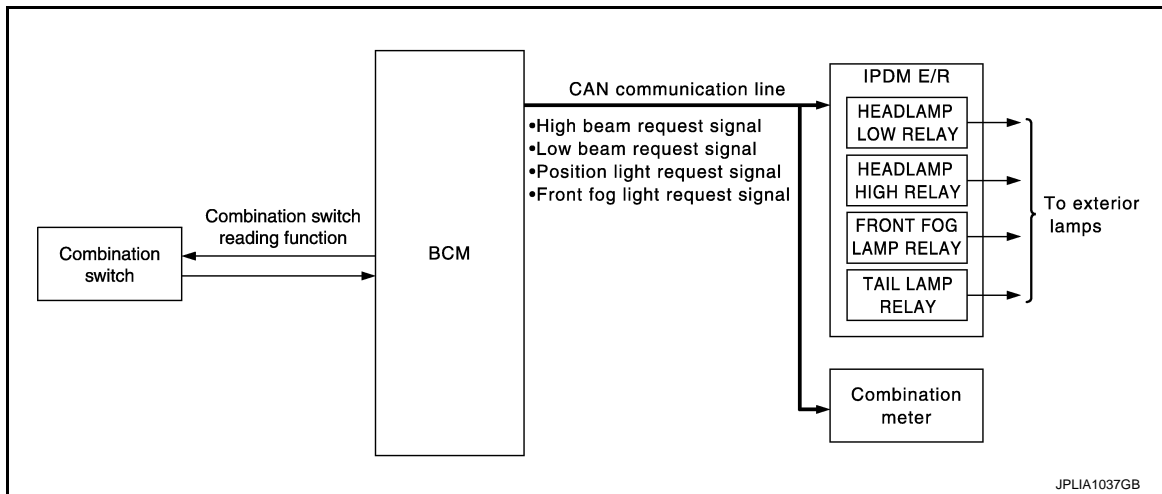

WITHOUT INTELLIGENT KEY

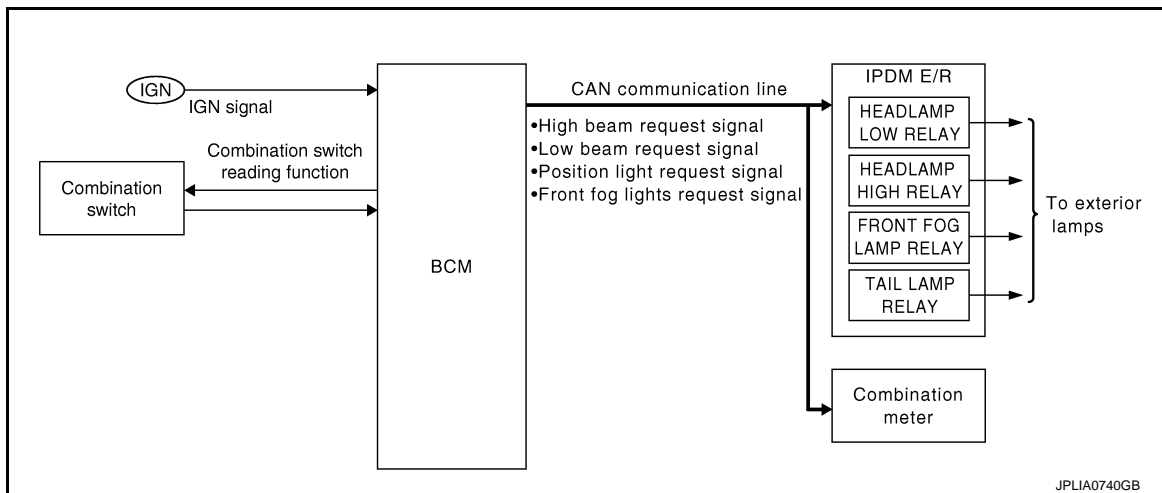

System Description

INFOID:000000004992201

OUTLINE

- Exterior lamp battery saver system is controlled by each function of BCM and IPDM E/R.

Control by BCM

- Combination switch reading function
- Headlamp control function
- Exterior lamp battery saver function

Control by IPDM E/R

- Relay control function
 - BCM turns the exterior lamp* OFF after a period of time to prevent the battery from over-discharge when the ignition switch is turned OFF with the exterior lamp ON.
- *: Headlamp (LO/HI), parking(front side marker) lamp, tail lamp, license plate lamp, rear side marker lamp and front fog lamp

EXTERIOR LAMP BATTERY SAVER ACTIVATION

BCM activates the timer and turns the exterior lamp OFF 5 minutes after the ignition switch is turned from ON → OFF with the exterior lamps ON.

NOTE:

EXTERIOR LAMP BATTERY SAVER SYSTEM

< SYSTEM DESCRIPTION >

- Headlamp control function turns the exterior lamps ON normally when the ignition switch is turned ACC or the engine started (both before and after the exterior lamp battery saver is turned OFF).
- The timer starts at the time that the lighting switch is turned from OFF → 1ST or 2ND with the exterior lamp OFF.

Component Parts Location

INFOID:000000004992202

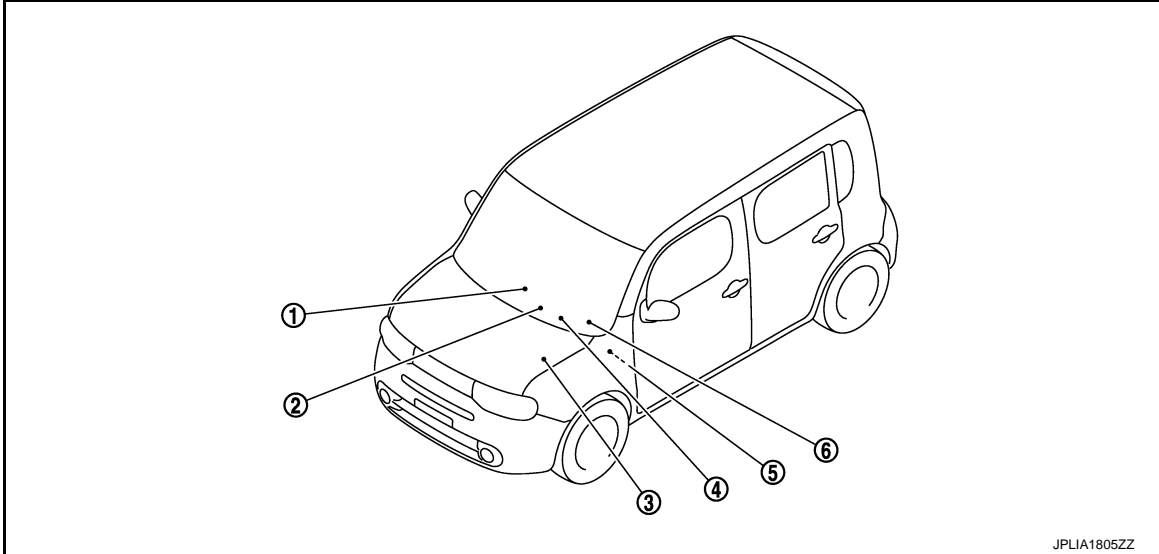

- | | | |
|--|--|---|
| 1. Push switch
(With Intelligent Key) | 2. Key switch
(Without Intelligent Key) | 3. IPDM E/R
Refer to PCS-6, "Component Parts Location" . |
| 4. Combination meter | 5. BCM
Refer to BCS-9, "Component Parts Location" . | 6. Combination switch |

Component Description

INFOID:000000004992203

Part	Description
BCM	<ul style="list-style-type: none"> • Detects each switch condition by the combination switch reading function. • Activates the battery saver to turn the exterior lamps OFF according to the vehicle condition. - Requests each relay OFF to IPDM E/R (with CAN communication).
IPDM E/R	Controls the integrated relay according to the request from BCM (with CAN communication).
Combination switch (Lighting & turn signal switch)	Refer to BCS-10, "System Diagram" .

DIAGNOSIS SYSTEM (BCM) (WITH INTELLIGENT KEY SYSTEM)

< SYSTEM DESCRIPTION >

DIAGNOSIS SYSTEM (BCM) (WITH INTELLIGENT KEY SYSTEM) COMMON ITEM

COMMON ITEM : CONSULT-III Function (BCM - COMMON ITEM)

INFOID:000000005185890

APPLICATION ITEM

CONSULT-III performs the following functions via CAN communication with BCM.

Diagnosis mode	Function Description
Work Support	Changes the setting for each system function.
Self Diagnostic Result	Displays the diagnosis results judged by BCM.
CAN Diag Support Monitor	Monitors the reception status of CAN communication viewed from BCM. Refer to CONSULT-III operation manual.
Data Monitor	The BCM input/output signals are displayed.
Active Test	The signals used to activate each device are forcibly supplied from BCM.
Ecu Identification	The BCM part number is displayed.
Configuration	<ul style="list-style-type: none"> Read and save the vehicle specification. Write the vehicle specification when replacing BCM.

SYSTEM APPLICATION

BCM can perform the following functions for each system.

NOTE:

It can perform the diagnosis modes except the following for all sub system selection items.

×: Applicable item

System	Sub system selection item	Diagnosis mode		
		Work Support	Data Monitor	Active Test
Door lock	DOOR LOCK	×	×	×
Rear window defogger	REAR DEFOGGER		×	×
Warning chime	BUZZER		×	×
Interior room lamp timer	INT LAMP	×	×	×
Exterior lamp	HEAD LAMP	×	×	×
Wiper and washer	WIPER	×	×	×
Turn signal and hazard warning lamps	FLASHER	×	×	×
Automatic air conditioner	AIR CONDITONER		×	×
<ul style="list-style-type: none"> Intelligent Key system Engine start system 	INTELLIGENT KEY	×	×	×
Combination switch	COMB SW		×	
Body control system	BCM	×		
NVIS - NATS	IMMU	×	×	×
Interior room lamp battery saver	BATTERY SAVER	×	×	×
Back door	TRUNK		×	
Vehicle security system	THEFT ALM	×	×	×
RAP system	RETAINED PWR		×	
Signal buffer system	SIGNAL BUFFER		×	×
TPMS	TPMS (AIR PRESSURE MONITOR)	×	×	×

FREEZE FRAME DATA (FFD)

The BCM records the following vehicle condition at the time a particular DTC is detected, and displays on CONSULT-III.

DIAGNOSIS SYSTEM (BCM) (WITH INTELLIGENT KEY SYSTEM)

< SYSTEM DESCRIPTION >

CONSULT screen item	Indication/Unit	Description		
Vehicle Speed	km/h	Vehicle speed of the moment a particular DTC is detected		A
Odo/Trip Meter	km	Total mileage (Odometer value) of the moment a particular DTC is detected		
Vehicle Condition	SLEEP>LOCK	Power position status of the moment a particular DTC is detected	While turning BCM status from low power consumption mode to normal mode (Power supply position is "LOCK")	B
	SLEEP>OFF		While turning BCM status from low power consumption mode to normal mode (Power supply position is "OFF".)	C
	LOCK>ACC		While turning power supply position from "LOCK" to "ACC"	
	ACC>ON		While turning power supply position from "ACC" to "IGN"	D
	RUN>ACC		While turning power supply position from "RUN" to "ACC" (Vehicle is stopping and selector lever is except P position.)	
	CRANK>RUN		While turning power supply position from "CRANKING" to "RUN" (From cranking up the engine to run it)	E
	RUN>URGENT		While turning power supply position from "RUN" to "ACC" (Emergency stop operation)	
	ACC>OFF		While turning power supply position from "ACC" to "OFF"	F
	OFF>LOCK		While turning power supply position from "OFF" to "LOCK"	
	OFF>ACC		While turning power supply position from "OFF" to "ACC"	G
	ON>CRANK		While turning power supply position from "IGN" to "CRANKING"	
	OFF>SLEEP		While turning BCM status from normal mode (Power supply position is "OFF".) to low power consumption mode	H
	LOCK>SLEEP		While turning BCM status from normal mode (Power supply position is "LOCK".) to low power consumption mode	
	LOCK		Power supply position is "LOCK" (Ignition switch OFF with steering is locked.)	I
	OFF		Power supply position is "OFF" (Ignition switch OFF with steering is unlocked.)	J
	ACC		Power supply position is "ACC" (Ignition switch ACC)	
	ON		Power supply position is "IGN" (Ignition switch ON with engine stopped)	K
ENGINE RUN	Power supply position is "RUN" (Ignition switch ON with engine running)			
CRANKING	Power supply position is "CRANKING" (At engine cranking)	EXL		
IGN Counter	0 - 39	The number of times that ignition switch is turned ON after DTC is detected <ul style="list-style-type: none"> • The number is 0 when a malfunction is detected now. • The number increases like 1 → 2 → 3...38 → 39 after returning to the normal condition whenever ignition switch OFF → ON. • The number is fixed to 39 until the self-diagnosis results are erased if it is over 39. 		M

HEADLAMP

HEADLAMP : CONSULT-III Function (BCM - HEAD LAMP)

INFOID:000000005116663

WORK SUPPORT

For USA

DIAGNOSIS SYSTEM (BCM) (WITH INTELLIGENT KEY SYSTEM)

< SYSTEM DESCRIPTION >

Service item	Setting item	Setting
AUTO LIGHT LOGIC SET	MODE 1 [*]	With twilight ON custom & with wiper INT, LO and HI
	MODE 2	With twilight ON custom & with wiper LO and HI
	MODE 3	With twilight ON custom & without
	MODE 4	Without twilight ON custom & with wiper INT, LO and HI
	MODE 5	Without twilight ON custom & with wiper LO and HI
	MODE 6	Without twilight ON custom & without
CUSTOM A/LIGHT SETTING	MODE 1 [*]	Normal
	MODE 2	More sensitive setting than normal setting (Turns ON earlier than normal operation.)
	MODE 3	More sensitive setting than MODE 2 (Turns ON earlier than MODE 2.)
	MODE 4	Without twilight ON custom & less sensitive setting than normal setting (Turns ON later than normal operation.)
BATTERY SAVER SET	On [*]	With the exterior lamp battery saver function
	Off	Without the exterior lamp battery saver function
ILL DELAY SET	MODE 1 [*]	45 sec.
	MODE 2	Without the function
	MODE 3	30 sec.
	MODE 4	60 sec.
	MODE 5	90 sec.
	MODE 6	120 sec.
	MODE 7	150 sec.
	MODE 8	180 sec.

Sets delay timer function timer operation time.
(All doors closed)

*: Factory setting

For CANADA

Service item	Setting item	Setting
AUTO LIGHT LOGIC SET	MODE 1	NOTE: The item is indicated, but not operated.
	MODE 2	
	MODE 3	
	MODE 4	
	MODE 5	
	MODE 6	
CUSTOM A/LIGHT SETTING	MODE 1 [*]	Normal
	MODE 2	More sensitive setting than normal setting (Turns ON earlier than normal operation.)
	MODE 3	More sensitive setting than MODE 2 (Turns ON earlier than MODE 2.)
	MODE 4	Less sensitive setting than normal setting (Turns ON later than normal operation.)
BATTERY SAVER SET	On [*]	With the exterior lamp battery saver function
	Off	Without the exterior lamp battery saver function

DIAGNOSIS SYSTEM (BCM) (WITH INTELLIGENT KEY SYSTEM)

< SYSTEM DESCRIPTION >

Service item	Setting item	Setting	
ILL DELAY SET	MODE 1*	45 sec.	Sets delay timer function timer operation time. (All doors closed)
	MODE 2	Without the function	
	MODE 3	30 sec.	
	MODE 4	60 sec.	
	MODE 5	90 sec.	
	MODE 6	120 sec.	
	MODE 7	150 sec.	
	MODE 8	180 sec.	

*: Factory setting

DATA MONITOR

Monitor item [Unit]	Description
PUSH SW [On/Off]	The switch status input from push-button ignition switch
ENGINE STATE [Stop/Stall/Crank/Run]	The engine status received from ECM with CAN communication
VEH SPEED 1 [km/h]	The value of the vehicle speed received from combination meter with CAN communication
HI BEAM SW [On/Off]	Each switch status that BCM judges from the combination switch reading function
HEAD LAMP SW1 [On/Off]	
HEAD LAMP SW2 [On/Off]	
LIGHT SW 1ST [On/Off]	
PASSING SW [On/Off]	
FR FOG SW [On/Off]	
AUTO LIGHT SW [On/Off]	
DOOR SW-DR [On/Off]	
DOOR SW-AS [On/Off]	The switch status input from front door switch (passenger side)
DOOR SW-RR [On/Off]	The switch status input from rear door switch RH
DOOR SW- RL [On/Off]	The switch status input from rear door switch LH
BACK DOOR SW [On/Off]	The switch status input from back door switch
TURN SIGNAL R [On/Off]	Each switch status that BCM judges from the combination switch reading function
TURN SIGNAL L [On/Off]	
TAIL LAMP SW [On/Off]	

DIAGNOSIS SYSTEM (BCM) (WITH INTELLIGENT KEY SYSTEM)

< SYSTEM DESCRIPTION >

Monitor item [Unit]	Description
OPTICAL SENSOR [On/Off]	The sensor status input from optical sensor
OPTI SEN (DTCT) [V]	The value of outside brightness voltage input from the optical sensor
OPTI SEN (FILT) [V]	The value of outside brightness voltage filtered by BCM

ACTIVE TEST

Test item	Operation	Description
TAIL LAMP	On	Transmits the position light request signal to IPDM E/R with CAN communication to turn the tail lamp ON.
	Off	Stops the tail lamp request signal transmission.
HEAD LAMP	Hi	Transmits the high beam request signal with CAN communication to turn the headlamp (HI).
	Lo	Transmits the low beam request signal with CAN communication to turn the headlamp (LO).
	Off	Stops the high & low beam request signal transmission.
FR FOG LAMP	On	Transmits the front fog lights request signal to IPDM E/R with CAN communication to turn the front fog lamp ON.
	Off	Stops the front fog lights request signal transmission.
ILL DIM SIGNAL	On	NOTE: The item is indicated, but cannot be tested.
	Off	

FLASHER

FLASHER : CONSULT-III Function (BCM - FLASHER)

INFOID:000000005117435

WORK SUPPORT

Service item	Setting item	Setting
HAZARD ANSWER BACK	Lock Only	With locking only
	Unlk Only	With unlocking only
	Lock/Unlk*	With locking/unlocking
	Off	Without the function
		Sets the hazard warning lamp answer back function when the door is lock/unlock with the request switch or the key fob.

*: Factory setting

DATA MONITOR

Monitor item [Unit]	Description
REQ SW-DR [On/Off]	The switch status input from the request switch (driver side)
REQ SW-AS [On/Off]	The switch status input from the request switch (passenger side)
PUSH SW [On/Off]	The switch status input from the push-button ignition switch
TURN SIGNAL R [On/Off]	Each switch status that BCM detects from the combination switch reading function
TURN SIGNAL L [On/Off]	

DIAGNOSIS SYSTEM (BCM) (WITH INTELLIGENT KEY SYSTEM)

< SYSTEM DESCRIPTION >

Monitor item [Unit]	Description
HAZARD SW [On/Off]	The switch status input from the hazard switch
RKE-LOCK [On/Off]	Lock signal status received from the remote keyless entry receiver
RKE-UNLOCK [On/Off]	Unlock signal status received from the remote keyless entry receiver
RKE-PANIC [On/Off]	Panic alarm signal status received from the remote keyless entry receiver

ACTIVE TEST

Test item	Operation	Description
FLASHER	RH	Outputs the voltage to blink the right side turn signal lamps.
	LH	Outputs the voltage to blink the left side turn signal lamps.
	Off	Stops the voltage to turn the turn signal lamps OFF.

A
B
C
D
E
F
G
H
I
J
K
L
M
N
O
P

EXL

DIAGNOSIS SYSTEM (BCM) (WITHOUT INTELLIGENT KEY SYSTEM)

< SYSTEM DESCRIPTION >

DIAGNOSIS SYSTEM (BCM) (WITHOUT INTELLIGENT KEY SYSTEM) COMMON ITEM

COMMON ITEM : CONSULT-III Function (BCM - COMMON ITEM)

INFOID:000000005185891

APPLICATION ITEM

CONSULT-III performs the following functions via CAN communication with BCM.

Diagnosis mode	Function Description
Work Support	Changes the setting for each system function.
Self Diagnostic Result	Displays the diagnosis results judged by BCM.
CAN Diag Support Monitor	Monitors the reception status of CAN communication viewed from BCM. Refer to CONSULT-III operation manual.
Data Monitor	The BCM input/output signals are displayed.
Active Test	The signals used to activate each device are forcibly supplied from BCM.
Ecu Identification	The BCM part number is displayed.
Configuration	<ul style="list-style-type: none"> • Read and save the vehicle specification. • Write the vehicle specification when replacing BCM.

SYSTEM APPLICATION

BCM can perform the following functions for each system.

NOTE:

It can perform the diagnosis modes except the following for all sub system selection items.

x: Applicable item

System	Sub system selection item	Diagnosis mode		
		Work Support	Data Monitor	Active Test
Door lock	DOOR LOCK	x	x	x
Rear window defogger	REAR DEFOGGER		x	x
Warning chime	BUZZER		x	x
Interior room lamp control	INT LAMP	x	x	x
Remote keyless entry system	MULTI REMOTE ENT	x	x	x
Exterior lamp	HEAD LAMP	x	x	x
Wiper and washer	WIPER	x	x	x
Turn signal and hazard warning lamps	FLASHER		x	x
<ul style="list-style-type: none"> • Automatic air conditioner • Manual air conditioner 	AIR CONDITONER		x	x
Combination switch	COMB SW		x	
Body control system	BCM	x		
NVIS - NATS	IMMU	x	x	x
Interior room lamp battery saver	BATTERY SAVER	x	x	x
Back door	TRUNK		x	
Vehicle security system	THEFT ALM	x	x	x
RAP system	RETAINED PWR		x	x
Signal buffer system	SIGNAL BUFFER		x	x
TPMS	TPMS (AIR PRESSURE MONITOR)	x	x	x
Panic alarm system	PANIC ALARM			x

HEADLAMP

DIAGNOSIS SYSTEM (BCM) (WITHOUT INTELLIGENT KEY SYSTEM)

< SYSTEM DESCRIPTION >

HEADLAMP : CONSULT-III Function (BCM - HEAD LAMP)

INFOID:000000005117440

WORK SUPPORT

For USA

A
B
C
D
E
F
G
H
I
J
K
EXL
M
N
O
P

Service item	Setting item	Setting	
AUTO LIGHT LOGIC SET	MODE 1*	With twilight ON custom & with wiper INT, LO and HI	
	MODE 2	With twilight ON custom & with wiper LO and HI	
	MODE 3	With twilight ON custom & without	
	MODE 4	Without twilight ON custom & with wiper INT, LO and HI	
	MODE 5	Without twilight ON custom & with wiper LO and HI	
	MODE 6	Without twilight ON custom & without	
BATTERY SAVER SET	On*	With the exterior lamp battery saver function	
	Off	Without the exterior lamp battery saver function	
ILL DELAY SET	MODE 1*	45 sec.	Sets delay timer function timer operation time. (All doors closed)
	MODE 2	Without the function	
	MODE 3	30 sec.	
	MODE 4	60 sec.	
	MODE 5	90 sec.	
	MODE 6	120 sec.	
	MODE 7	150 sec.	
	MODE 8	180 sec.	

*: Factory setting

For CANADA

Service item	Setting item	Setting	
AUTO LIGHT LOGIC SET	MODE 1	NOTE: The item is indicated, but not operated.	
	MODE 2		
	MODE 3		
	MODE 4		
	MODE 5		
	MODE 6		
BATTERY SAVER SET	On*	With the exterior lamp battery saver function	
	Off	Without the exterior lamp battery saver function	
ILL DELAY SET	MODE 1*	45 sec.	Sets delay timer function timer operation time. (All doors closed)
	MODE 2	Without the function	
	MODE 3	30 sec.	
	MODE 4	60 sec.	
	MODE 5	90 sec.	
	MODE 6	120 sec.	
	MODE 7	150 sec.	
	MODE 8	180 sec.	

*: Factory setting

DATA MONITOR

DIAGNOSIS SYSTEM (BCM) (WITHOUT INTELLIGENT KEY SYSTEM)

< SYSTEM DESCRIPTION >

Monitor item [Unit]	Description
IGN ON SW [On/Off]	Ignition switch (ON) status judged from IGN signal (ignition power supply)
ACC SW [On/Off]	Ignition switch (ACC) status judged from ACC signal (ACC power supply)
VEH SPEED [km/h]	The value of the vehicle speed received from combination meter with CAN communication
HI BEAM SW [On/Off]	Each switch status that BCM judges from the combination switch reading function
HEAD LAMP SW1 [On/Off]	
HEAD LAMP SW2 [On/Off]	
PASSING SW [On/Off]	
FR FOG SW [On/Off]	
AUTO LIGHT SW [On/Off]	
RR FOG SW [On/Off]	
DOOR SW-DR [On/Off]	The switch status input from front door switch (driver side)
DOOR SW-AS [On/Off]	The switch status input from front door switch (passenger side)
DOOR SW-RR [On/Off]	The switch status input from rear door switch RH
DOOR SW- RL [On/Off]	The switch status input from rear door switch LH
BACK DOOR SW [On/Off]	The switch status input from back door switch
TURN SIGNAL R [On/Off]	Each switch status that BCM judges from the combination switch reading function
TURN SIGNAL L [On/Off]	
TAIL LAMP SW [On/Off]	
KEY ON SW [On/Off]	The switch status input from key on switch
KEYLESS LOCK [On/Off]	Lock signal status received from remote keyless entry receiver (integrated in the BCM)
PKB SW [On/Off]	The parking brake switch status received from combination meter with CAN communication
ENGINE RUN [On/Off]	The engine status received from ECM with CAN communication
LIG SEN COND [On/Off]	The sensor condition received from light sensor
OPTI SEN (DTCT) [V]	The value of outside brightness voltage input from the optical sensor
OPTI SEN (FILT) [V]	The value of outside brightness voltage filtered by BCM

ACTIVE TEST

DIAGNOSIS SYSTEM (BCM) (WITHOUT INTELLIGENT KEY SYSTEM)

< SYSTEM DESCRIPTION >

Test item	Operation	Description
TAIL LAMP	On	Transmits the position light request signal to IPDM E/R with CAN communication to turn the tail lamp ON.
	Off	Stops the tail lamp request signal transmission.
HEAD LAMP	Hi	Transmits the high beam request signal with CAN communication to turn the headlamp (HI).
	Lo	Transmits the low beam request signal with CAN communication to turn the headlamp (LO).
	Off	Stops the high & low beam request signal transmission.
FR FOG LAMP	On	Transmits the front fog lights request signal to IPDM E/R with CAN communication to turn the front fog lamp ON.
	Off	Stops the front fog lights request signal transmission.
ILL DIM SIGNAL	On	NOTE: The item is indicated, but cannot be tested.
	Off	

FLASHER

FLASHER : CONSULT-III Function (BCM - FLASHER)

INFOID:000000005117443

DATA MONITOR

Monitor item [Unit]	Description
IGN ON SW [On/Off]	Ignition switch (ON) status judged from IGN signal (ignition power supply)
TURN SIGNAL R [On/Off]	Each switch status that BCM detects from the combination switch reading function
TURN SIGNAL L [On/Off]	
HAZARD SW [On/Off]	The switch status input from the hazard switch

ACTIVE TEST

Test item	Operation	Description
FLASHER	RH	Outputs the voltage to blink the right side turn signal lamps.
	LH	Outputs the voltage to blink the left side turn signal lamps.
	Off	Stops the voltage to turn the turn signal lamps OFF.

A
B
C
D
E
F
G
H
I
J
K
EXL
M
N
O
P

DIAGNOSIS SYSTEM (IPDM E/R) (WITH INTELLIGENT KEY SYSTEM)

< SYSTEM DESCRIPTION >

DIAGNOSIS SYSTEM (IPDM E/R) (WITH INTELLIGENT KEY SYSTEM)

Diagnosis Description

INFOID:000000005185892

AUTO ACTIVE TEST

Description

In auto active test mode, the IPDM E/R sends a drive signal to the following systems to check their operation.

- Oil pressure warning lamp
- Rear window defogger
- Front wiper (LO, HI)
- Parking lamps
- Side marker lamp
- License plate lamps
- Tail lamps
- Front fog lamps
- Headlamps (LO, HI)
- A/C compressor (magnet clutch)
- Cooling fan

Operation Procedure

1. Close the hood and lift the wiper arms from the windshield. (Prevent windshield damage due to wiper operation)

NOTE:

When auto active test is performed with hood opened, sprinkle water on windshield beforehand.

2. Turn the ignition switch OFF.
3. Turn the ignition switch ON, and within 20 seconds, press the driver door switch 10 times. Then turn the ignition switch OFF.

CAUTION:

Close passenger door.

4. Turn the ignition switch ON within 10 seconds. After that the horn sounds once and the auto active test starts.
5. The oil pressure warning lamp starts blinking when the auto active test starts.
6. After a series of the following operations is repeated 3 times, auto active test is completed.

NOTE:

When auto active test mode has to be cancelled halfway through test, turn the ignition switch OFF.

CAUTION:

- **If auto active test mode cannot be actuated, check door switch system. Refer to [DLK-55, "Component Function Check"](#).**
- **Do not start the engine.**

Inspection in Auto Active Test Mode

When auto active test mode is actuated, the following 6 steps are repeated 3 times.

Operation sequence	Inspection location	Operation
A	Oil pressure warning lamp	Blinks continuously during operation of auto active test
1	Rear window defogger	10 seconds
2	Front wiper	LO for 5 seconds → HI for 5 seconds
3	<ul style="list-style-type: none">• Parking lamps• Side marker lamps• License plate lamps• Tail lamps• Front fog lamps	10 seconds
4	Headlamps	LO for 10 seconds → HI ON ↔ OFF 5 times
5	A/C compressor (magnet clutch)	ON ↔ OFF 5 times
6	Cooling fan	LO for 5 seconds → HI for 5 seconds

DIAGNOSIS SYSTEM (IPDM E/R) (WITH INTELLIGENT KEY SYSTEM)

< SYSTEM DESCRIPTION >

Concept of auto active test

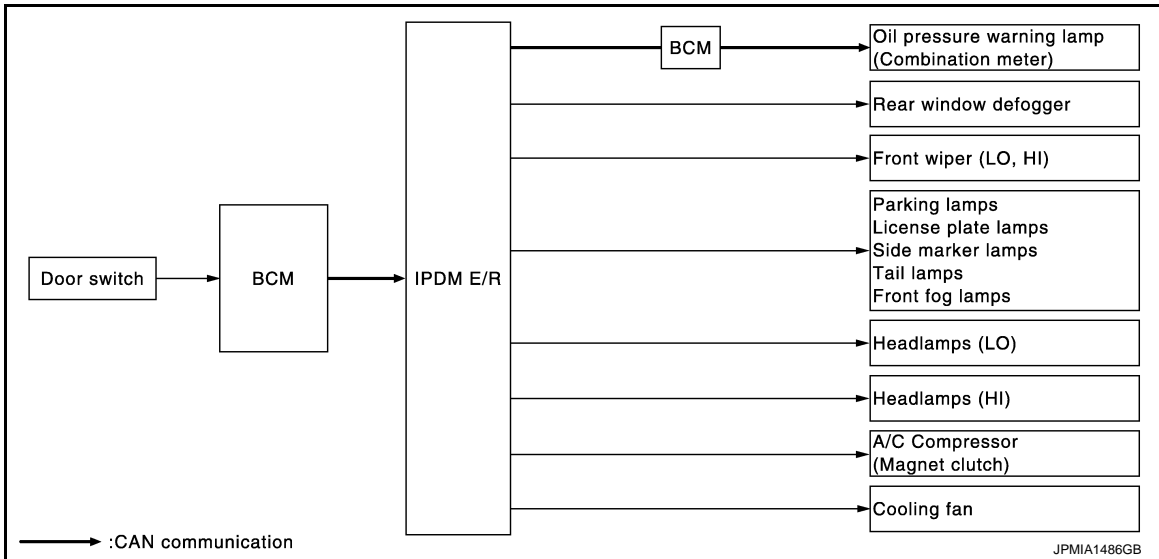

- IPDM E/R starts the auto active test with the door switch signals transmitted by BCM via CAN communication. Therefore, the CAN communication line between IPDM E/R and BCM is considered normal if the auto active test starts successfully.
- The auto active test facilitates troubleshooting if any systems controlled by IPDM E/R cannot be operated.

Diagnosis chart in auto active test mode

Symptom	Inspection contents	Possible cause
Rear window defogger does not operate	Perform auto active test. Does the rear window defogger operate?	YES BCM signal input circuit
		NO <ul style="list-style-type: none"> • Rear window defogger • Rear window defogger ground circuit • Harness or connector between IPDM E/R and rear window defogger • IPDM E/R
<ul style="list-style-type: none"> • Any of the following components do not operate • Parking lamps • Side marker lamps • License plate lamps • Tail lamps • Front fog lamps • Headlamps (HI, LO) • Front wiper (HI, LO) 	Perform auto active test. Does the applicable system operate?	YES BCM signal input circuit
		NO <ul style="list-style-type: none"> • Lamp or motor • Lamp or motor ground circuit • Harness or connector between IPDM E/R and applicable system • IPDM E/R
A/C compressor does not operate	Perform auto active test. Does the magnet clutch operate?	YES <ul style="list-style-type: none"> • A/C amp. signal input circuit • CAN communication signal between A/C amp. and ECM • CAN communication signal between ECM and IPDM E/R
		NO <ul style="list-style-type: none"> • Magnet clutch • Harness or connector between IPDM E/R and magnet clutch • IPDM E/R

DIAGNOSIS SYSTEM (IPDM E/R) (WITH INTELLIGENT KEY SYSTEM)

< SYSTEM DESCRIPTION >

Symptom	Inspection contents	Possible cause
Oil pressure warning lamp does not operate	Perform auto active test. Does the oil pressure warning lamp blink?	YES <ul style="list-style-type: none"> • Harness or connector between IPDM E/R and oil pressure switch • Oil pressure switch • IPDM E/R
		NO <ul style="list-style-type: none"> • CAN communication signal between IPDM E/R and BCM • CAN communication signal between BCM and combination meter • Combination meter
Cooling fan does not operate	Perform auto active test. Does the cooling fan operate?	YES <ul style="list-style-type: none"> • ECM signal input circuit • CAN communication signal between ECM and IPDM E/R
		NO <ul style="list-style-type: none"> • Cooling fan motor • Harness or connector between IPDM E/R and cooling fan motor • IPDM E/R

CONSULT-III Function (IPDM E/R)

INFOID:000000005185893

APPLICATION ITEM

CONSULT-III performs the following functions via CAN communication with IPDM E/R.

Diagnosis mode	Description
Ecu Identification	Allows confirmation of IPDM E/R part number.
Self Diagnostic Result	Displays the diagnosis results judged by IPDM E/R.
Data Monitor	Displays the real-time input/output data from IPDM E/R input/output data.
Active Test	IPDM E/R can provide a drive signal to electronic components to check their operations.
CAN Diag Support Monitor	The results of transmit/receive diagnosis of CAN communication can be read.

SELF DIAGNOSTIC RESULT

Refer to [PCS-33, "DTC Index"](#).

DATA MONITOR

Monitor item

Monitor Item [Unit]	MAIN SIGNALS	Description
MOTOR FAN REQ [1/2/3/4]	×	Displays the value of the cooling fan speed request signal received from ECM via CAN communication.
AC COMP REQ [Off/On]	×	Displays the status of the A/C compressor request signal received from ECM via CAN communication.
TAIL&CLR REQ [Off/On]	×	Displays the status of the position light request signal received from BCM via CAN communication.
HL LO REQ [Off/On]	×	Displays the status of the low beam request signal received from BCM via CAN communication.
HL HI REQ [Off/On]	×	Displays the status of the high beam request signal received from BCM via CAN communication.
FR FOG REQ [Off/On]	×	Displays the status of the front fog light request signal received from BCM via CAN communication.
FR WIP REQ [Stop/1LOW/Low/Hi]	×	Displays the status of the front wiper request signal received from BCM via CAN communication.

DIAGNOSIS SYSTEM (IPDM E/R) (WITH INTELLIGENT KEY SYSTEM)

< SYSTEM DESCRIPTION >

Monitor Item [Unit]	MAIN SIG- NALS	Description
WIP AUTO STOP [STOP P/ACT P]	×	Displays the status of the front wiper auto stop signal judged by IPDM E/R.
WIP PROT [Off/BLOCK]	×	Displays the status of the front wiper fail-safe operation judged by IPDM E/R.
IGN RLY1 -REQ [Off/On]		Displays the status of the ignition switch ON signal received from BCM via CAN communication.
IGN RLY [Off/On]	×	Displays the status of the ignition relay judged by IPDM E/R.
PUSH SW [Off/On]		Displays the status of the push-button ignition switch judged by IPDM E/R.
INTER/NP SW [Off/On]		Displays the status of the clutch interlock switch (M/T models) or shift position (CVT models) judged by IPDM E/R.
ST RLY CONT [Off/On]		Displays the status of the starter relay status signal received from BCM via CAN communication.
IHBT RLY -REQ [Off/On]		Displays the status of the starter control relay signal received from BCM via CAN communication.
ST/INHI RLY [Off/ ST ON/INHI ON/UNKWN]		Displays the status of the starter relay and starter control relay judged by IPDM E/R.
DETENT SW [Off/On]		Displays the status of the CVT shift selector (detention switch) judged by IPDM E/R.
S/L RLY -REQ [Off/On]		Displays the status of the steering lock relay signal received from BCM via CAN communication.
S/L STATE [LOCK/UNLOCK/UNKWN]		Displays the status of the steering lock judged by IPDM E/R.
DTRL REQ [Off/On]		Displays the status of the daytime running light request signal received from BCM via CAN communication. NOTE: This item is monitored only the vehicle with daytime running light system.
OIL P SW [Open/Close]		Displays the status of the oil pressure switch judged by IPDM E/R.
HOOD SW [Off/On]		NOTE: The item is indicated, but not monitored.
THFT HRN REQ [Off/On]		Displays the status of the theft warning horn request signal received from BCM via CAN communication.
HORN CHIRP [Off/On]		Displays the status of the horn reminder signal received from BCM via CAN communication.

ACTIVE TEST

Test item

Test item	Operation	Description
HORN	On	Operates horn relay for 20 ms.
FRONT WIPER	Off	OFF
	Lo	Operates the front wiper relay.
	Hi	Operates the front wiper relay and front wiper high relay.
MOTOR FAN	1	OFF
	2	Operates the cooling fan relay (LO operation).
	3	Operates the cooling fan relay (HI operation).
	4	

DIAGNOSIS SYSTEM (IPDM E/R) (WITH INTELLIGENT KEY SYSTEM)

< SYSTEM DESCRIPTION >

Test item	Operation	Description
EXTERNAL LAMPS	Off	OFF
	TAIL	Operates the tail lamp relay.
	Lo	Operates the headlamp low relay.
	Hi	Operates the headlamp low relay and ON/OFF the headlamp high relay at 1 second intervals.
	Fog	Operates the front fog lamp relay.

DIAGNOSIS SYSTEM (IPDM E/R) (WITHOUT INTELLIGENT KEY SYSTEM)

< SYSTEM DESCRIPTION >

DIAGNOSIS SYSTEM (IPDM E/R) (WITHOUT INTELLIGENT KEY SYSTEM)

Diagnosis Description

INFOID:000000005185894

AUTO ACTIVE TEST

Description

In auto active test mode, the IPDM E/R sends a drive signal to the following systems to check their operation.

- Oil pressure warning lamp
- Rear window defogger
- Front wiper (LO, HI)
- Parking lamps
- Side marker lamp
- License plate lamps
- Tail lamps
- Front fog lamps
- Headlamps (LO, HI)
- A/C compressor (magnet clutch)
- Cooling fan

Operation Procedure

1. Close the hood and lift the wiper arms from the windshield. (Prevent windshield damage due to wiper operation)

NOTE:

When auto active test is performed with hood opened, sprinkle water on windshield beforehand.

2. Turn the ignition switch OFF.
3. Turn the ignition switch ON, and within 20 seconds, press the driver door switch 10 times. Then turn the ignition switch OFF.

CAUTION:

Close passenger door.

4. Turn the ignition switch ON within 10 seconds. After that the horn sounds once and the auto active test starts.
5. The oil pressure warning lamp starts blinking when the auto active test starts.
6. After a series of the following operations is repeated 3 times, auto active test is completed.

NOTE:

When auto active test mode has to be cancelled halfway through test, turn the ignition switch OFF.

CAUTION:

- If auto active test mode cannot be actuated, check door switch system. Refer to [DLK-55, "Component Function Check"](#).
- Do not start the engine.

Inspection in Auto Active Test Mode

When auto active test mode is actuated, the following 6 steps are repeated 3 times.

Operation sequence	Inspection location	Operation
A	Oil pressure warning lamp	Blinks continuously during operation of auto active test
1	Rear window defogger	10 seconds
2	Front wiper	LO for 5 seconds → HI for 5 seconds
3	<ul style="list-style-type: none">• Parking lamps• Side marker lamps• License plate lamps• Tail lamps• Front fog lamps	10 seconds
4	Headlamps	LO for 10 seconds → HI ON ↔ OFF 5 times

DIAGNOSIS SYSTEM (IPDM E/R) (WITHOUT INTELLIGENT KEY SYSTEM)

< SYSTEM DESCRIPTION >

Operation sequence	Inspection location	Operation
5	A/C compressor (magnet clutch)	ON ⇔ OFF 5 times
6	Cooling fan	LO for 5 seconds → HI for 5 seconds

Concept of auto active test

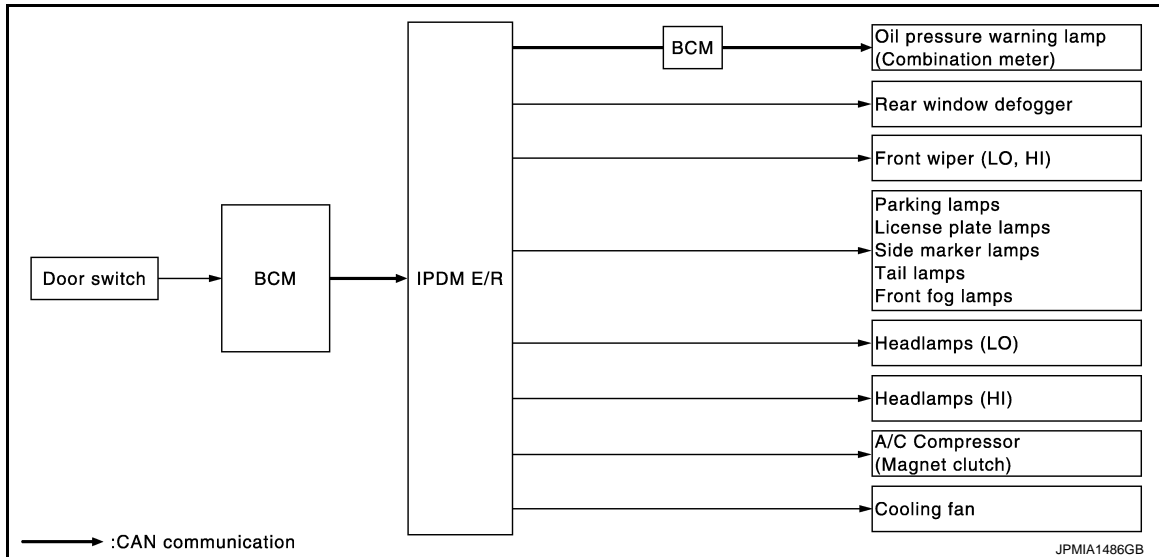

- IPDM E/R starts the auto active test with the door switch signals transmitted by BCM via CAN communication. Therefore, the CAN communication line between IPDM E/R and BCM is considered normal if the auto active test starts successfully.
- The auto active test facilitates troubleshooting if any systems controlled by IPDM E/R cannot be operated.

Diagnosis chart in auto active test mode

Symptom	Inspection contents	Possible cause
Rear window defogger does not operate	Perform auto active test. Does the rear window defogger operate?	YES BCM signal input circuit
		NO <ul style="list-style-type: none"> • Rear window defogger • Rear window defogger ground circuit • Harness or connector between IPDM E/R and rear window defogger • IPDM E/R
Any of the following components do not operate <ul style="list-style-type: none"> • Parking lamps • Side marker lamps • License plate lamps • Tail lamps • Front fog lamps • Headlamps (HI, LO) • Front wiper (HI, LO) 	Perform auto active test. Does the applicable system operate?	YES BCM signal input circuit
		NO <ul style="list-style-type: none"> • Lamp or motor • Lamp or motor ground circuit • Harness or connector between IPDM E/R and applicable system • IPDM E/R
A/C compressor does not operate	Perform auto active test. Does the magnet clutch operate?	YES <ul style="list-style-type: none"> • A/C amp. signal input circuit • CAN communication signal between A/C amp. and ECM • CAN communication signal between ECM and IPDM E/R
		NO <ul style="list-style-type: none"> • Magnet clutch • Harness or connector between IPDM E/R and magnet clutch • IPDM E/R

DIAGNOSIS SYSTEM (IPDM E/R) (WITHOUT INTELLIGENT KEY SYSTEM)

< SYSTEM DESCRIPTION >

Symptom	Inspection contents		Possible cause
Oil pressure warning lamp does not operate	Perform auto active test. Does the oil pressure warning lamp blink?	YES	<ul style="list-style-type: none"> • Harness or connector between IPDM E/R and oil pressure switch • Oil pressure switch • IPDM E/R
		NO	<ul style="list-style-type: none"> • CAN communication signal between IPDM E/R and BCM • CAN communication signal between BCM and combination meter • Combination meter
Cooling fan does not operate	Perform auto active test. Does the cooling fan operate?	YES	<ul style="list-style-type: none"> • ECM signal input circuit • CAN communication signal between ECM and IPDM E/R
		NO	<ul style="list-style-type: none"> • Cooling fan motor • Harness or connector between IPDM E/R and cooling fan motor • IPDM E/R

CONSULT-III Function (IPDM E/R)

INFOID:000000005185895

APPLICATION ITEM

CONSULT-III performs the following functions via CAN communication with IPDM E/R.

Diagnosis mode	Description
Ecu Identification	Allows confirmation of IPDM E/R part number.
Self Diagnostic Result	Displays the diagnosis results judged by IPDM E/R.
Data Monitor	Displays the real-time input/output data from IPDM E/R input/output data.
Active Test	IPDM E/R can provide a drive signal to electronic components to check their operations.
CAN Diag Support Monitor	The results of transmit/receive diagnosis of CAN communication can be read.

SELF DIAGNOSTIC RESULT

Refer to [PCS-63, "DTC Index"](#).

DATA MONITOR

Monitor item

Monitor Item [Unit]	MAIN SIGNALS	Description
MOTOR FAN REQ [1/2/3/4]	×	Displays the value of the cooling fan speed request signal received from ECM via CAN communication.
AC COMP REQ [Off/On]	×	Displays the status of the A/C compressor request signal received from ECM via CAN communication.
TAIL&CLR REQ [Off/On]	×	Displays the status of the position light request signal received from BCM via CAN communication.
HL LO REQ [Off/On]	×	Displays the status of the low beam request signal received from BCM via CAN communication.
HL HI REQ [Off/On]	×	Displays the status of the high beam request signal received from BCM via CAN communication.
FR FOG REQ [Off/On]	×	Displays the status of the front fog light request signal received from BCM via CAN communication.
FR WIP REQ [Stop/1LOW/Low/Hi]	×	Displays the status of the front wiper request signal received from BCM via CAN communication.

DIAGNOSIS SYSTEM (IPDM E/R) (WITHOUT INTELLIGENT KEY SYSTEM)

< SYSTEM DESCRIPTION >

Monitor Item [Unit]	MAIN SIG- NALS	Description
WIP AUTO STOP [STOP P/ACT P]	×	Displays the status of the front wiper auto stop signal judged by IPDM E/R.
WIP PROT [Off/BLOCK]	×	Displays the status of the front wiper fail-safe operation judged by IPDM E/R.
IGN RLY [Off/On]	×	Displays the status of the ignition relay judged by IPDM E/R.
INTER/NP SW [Off/On]		Displays the status of the shift position (CVT models) judged by IPDM E/R.
ST RLY-REQ [Off/On]		Displays the status of the starter relay status signal received from BCM via CAN communication.
DTRL REQ [Off/On]		Displays the status of the daytime running light request signal received from BCM via CAN communication. NOTE: This item is monitored only the vehicle with daytime running light system.
OIL P SW [Open/Close]		Displays the status of the oil pressure switch judged by IPDM E/R.
HOOD SW [Off/On]		NOTE: The item is indicated, but not monitored.
THFT HRN REQ [Off/On]		Displays the status of the theft warning horn request signal received from BCM via CAN communication.
HORN CHIRP [Off/On]		Displays the status of the horn reminder signal received from BCM via CAN communication.

ACTIVE TEST

Test item

Test item	Operation	Description
HORN	On	Operates horn relay for 20 ms.
FRONT WIPER	Off	OFF
	Lo	Operates the front wiper relay.
	Hi	Operates the front wiper relay and front wiper high relay.
MOTOR FAN	1	OFF
	2	Operates the cooling fan relay (LO operation).
	3	Operates the cooling fan relay (HI operation).
	4	
EXTERNAL LAMPS	Off	OFF
	TAIL	Operates the tail lamp relay.
	Lo	Operates the headlamp low relay.
	Hi	Operates the headlamp low relay and ON/OFF the headlamp high relay at 1 second intervals.
	Fog	Operates the front fog lamp relay.

POWER SUPPLY AND GROUND CIRCUIT

< DTC/CIRCUIT DIAGNOSIS >

DTC/CIRCUIT DIAGNOSIS

POWER SUPPLY AND GROUND CIRCUIT

BCM (BODY CONTROL SYSTEM) (WITH INTELLIGENT KEY SYSTEM)

BCM (BODY CONTROL SYSTEM) (WITH INTELLIGENT KEY SYSTEM) : Diagnosis Procedure

INFOID:000000005185896

1. CHECK FUSE AND FUSIBLE LINK

Check that the following fuse and fusible link are not blown.

Signal name	Fuse and fusible link No.
Battery power supply	G
	8

Is the fuse fusing?

YES >> Replace the blown fuse or fusible link after repairing the affected circuit if a fuse or fusible link is blown.

NO >> GO TO 2.

2. CHECK POWER SUPPLY CIRCUIT

1. Turn ignition switch OFF.
2. Disconnect BCM connectors.
3. Check voltage between BCM harness connector and ground.

Terminals		Voltage (Approx.)
(+)	(-)	
BCM		Ground Battery voltage
Connector	Terminal	
M70	70	
	57	

Is the measurement value normal?

YES >> GO TO 3.

NO >> Repair harness or connector.

3. CHECK GROUND CIRCUIT

Check continuity between BCM harness connector and ground.

BCM		Ground	Continuity
Connector	Terminal		
M70	67		Existed

Does continuity exist?

YES >> INSPECTION END

NO >> Repair harness or connector.

BCM (BODY CONTROL SYSTEM) (WITHOUT INTELLIGENT KEY SYSTEM)

BCM (BODY CONTROL SYSTEM) (WITHOUT INTELLIGENT KEY SYSTEM) : Diagnosis Procedure

INFOID:000000005185897

1. CHECK FUSES AND FUSIBLE LINK

Check that the following fuses and fusible link are not fusing.

A
B
C
D
E
F
G
H
I
J
K
EXL
M
N
O
P

POWER SUPPLY AND GROUND CIRCUIT

< DTC/CIRCUIT DIAGNOSIS >

Signal name	Fuses and fusible link No.
Battery power supply	8
	G
ACC power supply	20
Ignition power supply	2

Is the fuse fusing?

YES >> Replace the blown fuse or fusible link after repairing the affected circuit if a fuse or fusible link is blown.

NO >> GO TO 2.

2.CHECK POWER SUPPLY CIRCUIT

1. Turn ignition switch OFF.
2. Disconnect BCM connectors.
3. Check voltage between BCM harness connector and ground.

Terminals		(-)	Ignition switch position		
BCM			OFF	ACC	ON
Connector	Terminal	Ground			
M67	70		Battery voltage	Battery voltage	Battery voltage
	57				
M65	11		Approx. 0 V	Battery voltage	Battery voltage
	38	Approx. 0 V	Approx. 0 V	Battery voltage	

Is the measurement value normal?

YES >> GO TO 3.

NO >> Repair harness or connector.

3.CHECK GROUND CIRCUIT

Check continuity between BCM harness connector and ground.

BCM		Ground	Continuity
Connector	Terminal		
M67	67		Existed

Does continuity exist?

YES >> INSPECTION END

NO >> Repair harness or connector.

IPDM E/R (WITH INTELLIGENT KEY SYSTEM)

IPDM E/R (WITH INTELLIGENT KEY SYSTEM) : Diagnosis Procedure

INFOID:0000000005185898

1.CHECK FUSES AND FUSIBLE LINK

Check that the following IPDM E/R fuses or fusible links are not blown.

Signal name	Fuses and fusible link No.
Battery power supply	C
	D
	J

Is the fuse fusing?

POWER SUPPLY AND GROUND CIRCUIT

< DTC/CIRCUIT DIAGNOSIS >

- YES >> Replace the blown fuse or fusible link after repairing the affected circuit if a fuse or fusible link is blown.
- NO >> GO TO 2.

2.CHECK POWER SUPPLY CIRCUIT

1. Turn the ignition switch OFF.
2. Disconnect IPDM E/R connector.
3. Check voltage between IPDM E/R harness connector and the ground.

Terminals		Voltage (Approx.)
(+)	(-)	
IPDM E/R		Battery voltage
Connector	Terminal	
E9	1	
	2	
E10	8	

Is the measurement value normal?

- YES >> GO TO 3.
- NO >> Repair the harness or connector.

3.CHECK GROUND CIRCUIT

Check continuity between IPDM E/R harness connectors and the ground.

IPDM E/R		Ground	Continuity
Connector	Terminal		
E11	9		Existed
E12	19		

Does continuity exist?

- YES >> INSPECTION END
- NO >> Repair the harness or connector.

IPDM E/R (WITHOUT INTELLIGENT KEY SYSTEM)

IPDM E/R (WITHOUT INTELLIGENT KEY SYSTEM) : Diagnosis Procedure

INFOID:000000005185899

EXL

1.CHECK FUSES AND FUSIBLE LINK

Check that the following IPDM E/R fuses or fusible links are not blown.

Signal name	Fuses and fusible link No.
Battery power supply	C
	D
	J

Is the fuse fusing?

- YES >> Replace the blown fuse or fusible link after repairing the affected circuit if a fuse or fusible link is blown.
- NO >> GO TO 2.

2.CHECK POWER SUPPLY CIRCUIT

1. Turn the ignition switch OFF.
2. Disconnect IPDM E/R connector.
3. Check voltage between IPDM E/R harness connector and the ground.

POWER SUPPLY AND GROUND CIRCUIT

< DTC/CIRCUIT DIAGNOSIS >

Terminals		(-)	Voltage (Approx.)
(+)	IPDM E/R		
Connector	Terminal	Ground	Battery voltage
E9	1		
	2		
E10	8		

Is the measurement value normal?

YES >> GO TO 3.

NO >> Repair the harness or connector.

3.CHECK IGNITION POWER SUPPLY CIRCUIT

1. Turn the ignition switch ON.
2. Check voltage between IPDM E/R harness connector and the ground.

Terminals		(-)	Voltage (Approx.)
(+)	IPDM E/R		
Connector	Terminal	Ground	Battery voltage
E12	18		

Is the measurement value normal?

YES >> GO TO 4.

NO >> Repair the harness or connector.

4.CHECK GROUND CIRCUIT

1. Turn the ignition switch OFF.
2. Check continuity between IPDM E/R harness connectors and the ground.

IPDM E/R		Ground	Continuity
Connector	Terminal		Existed
E11	9		Existed
E12	19		

Does continuity exist?

YES >> INSPECTION END

NO >> Repair the harness or connector.

EXTERIOR LAMP FUSE

< DTC/CIRCUIT DIAGNOSIS >

EXTERIOR LAMP FUSE

WITHOUT DAYTIME RUNNING LIGHT SYSTEM

WITHOUT DAYTIME RUNNING LIGHT SYSTEM : Description

INFOID:000000004991962

Fuse list

Unit	Location	Fuse No.	Capacity
Headlamp HI (LH)	IPDM E/R	#52	10 A
Headlamp HI (RH)	IPDM E/R	#51	10 A
Headlamp LO (LH)	IPDM E/R	#53	15 A
Headlamp LO (RH)	IPDM E/R	#54	15 A
Front fog lamp	IPDM E/R	#50	15 A
<ul style="list-style-type: none">• Parking lamp (also used as the front side marker lamp)• Tail lamp• Rear side marker lamp• License plate lamp• Each illumination	IPDM E/R	#47	10 A
Stop lamp	FUSE BLOCK (J/B)	#7	10 A
Back-up lamp	IPDM E/R	#55	10 A

WITHOUT DAYTIME RUNNING LIGHT SYSTEM : Diagnosis Procedure

INFOID:000000004991963

1. CHECK FUSE

Check that the following fuses are not fusing.

Unit	Location	Fuse No.	Capacity
Headlamp HI (LH)	IPDM E/R	#52	10 A
Headlamp HI (RH)	IPDM E/R	#51	10 A
Headlamp LO (LH)	IPDM E/R	#53	15 A
Headlamp LO (RH)	IPDM E/R	#54	15 A
Front fog lamp	IPDM E/R	#50	15 A
<ul style="list-style-type: none">• Parking lamp (also used as the front side marker lamp)• Tail lamp• Rear side marker lamp• License plate lamp• Each illumination	IPDM E/R	#47	10 A
Stop lamp	FUSE BLOCK (J/B)	#7	10 A
Back-up lamp	IPDM E/R	#55	10 A

Is the fuse fusing?

YES >> Repair the applicable circuit. And then replace the fuse.

NO >> The fuse is normal.

WITH DAYTIME RUNNING LIGHT SYSTEM

WITH DAYTIME RUNNING LIGHT SYSTEM : Description

INFOID:000000004991964

Fuse list

Unit	Location	Fuse No.	Capacity
Headlamp HI (LH)	IPDM E/R	#52	10 A
Headlamp HI (RH)	IPDM E/R	#51	10 A

EXTERIOR LAMP FUSE

< DTC/CIRCUIT DIAGNOSIS >

Unit	Location	Fuse No.	Capacity
Headlamp LO (LH)	IPDM E/R	#53	15 A
Headlamp LO (RH)	IPDM E/R	#54	15 A
Front fog lamp	IPDM E/R	#50	15 A
<ul style="list-style-type: none"> • Parking lamp (also used as the front side marker lamp) • Tail lamp • Rear side marker lamp • License plate lamp • Each illumination 	IPDM E/R	#47	10 A
Stop lamp	FUSE BLOCK (J/B)	#7	10 A
Back-up lamp	IPDM E/R	#55	10 A

WITH DAYTIME RUNNING LIGHT SYSTEM : Diagnosis Procedure

INFOID:000000004991965

1. CHECK FUSE

Check that the following fuses are not fusing.

Unit	Location	Fuse No.	Capacity
Headlamp HI (LH)	IPDM E/R	#52	10 A
Headlamp HI (RH)	IPDM E/R	#51	10 A
Headlamp LO (LH)	IPDM E/R	#53	15 A
Headlamp LO (RH)	IPDM E/R	#54	15 A
Front fog lamp	IPDM E/R	#50	15 A
<ul style="list-style-type: none"> • Parking lamp (also used as the front side marker lamp) • Tail lamp • Rear side marker lamp • License plate lamp • Each illumination 	IPDM E/R	#47	10 A
Stop lamp	FUSE BLOCK (J/B)	#7	10 A
Back-up lamp	IPDM E/R	#55	10 A

Is the fuse fusing?

- YES >> Repair the applicable circuit. And then replace the fuse.
 NO >> The fuse is normal.

HEADLAMP (HI) CIRCUIT

< DTC/CIRCUIT DIAGNOSIS >

HEADLAMP (HI) CIRCUIT

Component Function Check

INFOID:000000004991966

1. CHECK HEADLAMP (HI) OPERATION

IPDM E/R AUTO ACTIVE TEST

1. Start IPDM E/R auto active test. Refer to [EXL-32, "Diagnosis Description"](#).
2. Check that the headlamp switches to the high beam.

CONSULT-III ACTIVE TEST

1. Select "EXTERNAL LAMPS" of IPDM E/R active test item.
2. With operating the test items, check that the headlamp (HI) is turned ON.

Hi : Headlamp (HI) ON

Off : Headlamp (HI) OFF

NOTE:

ON/OFF is repeated 1 second each.

Is the headlamp (HI) turned ON?

YES >> Headlamp (HI) circuit is normal.

NO >> Refer to [EXL-47, "Diagnosis Procedure"](#).

Diagnosis Procedure

INFOID:000000005136762

1. CHECK HEADLAMP (HI) OUTPUT VOLTAGE

CONSULT-III ACTIVE TEST

1. Turn the ignition switch OFF.
2. Disconnect the headlamp connector.
3. Turn the ignition switch ON.
4. Select "EXTERNAL LAMPS" of IPDM E/R active test item.
5. With operating the test items, check the voltage between the IPDM E/R harness connector and the ground.

Terminals			Test item	Voltage (Approx.)		
(+)	(-)					
IPDM E/R			EXTERNAL LAMPS	Battery voltage		
Connector	Terminal					
RH	E15	49			Hi	Battery voltage
LH		50			Off	0 V
			Hi	Battery voltage		
			Off	0 V		

Is the measurement value normal?

YES >> GO TO 2.

NO >> GO TO 3.

2. CHECK HEADLAMP (HI) OPEN CIRCUIT

1. Turn the ignition switch OFF.
2. Disconnect the IPDM E/R connector.
3. Check continuity between the IPDM E/R harness connector and the headlamp harness connector.

HEADLAMP (HI) CIRCUIT

< DTC/CIRCUIT DIAGNOSIS >

IPDM E/R		Headlamp		Continuity
Connector	Terminal	Connector	Terminal	
RH	E15	49	E45	Existed
LH		50	E26	

Does continuity exist?

YES (Without daytime running light system)>>GO TO 5.

YES (With daytime running light system)>>GO TO 6.

NO >> Repair the harnesses or connectors.

3.CHECK HEADLAMP (HI) FUSE

1. Turn the ignition switch OFF.
2. Check that the following fuses are not fusing.

Unit	Location	Fuse No.	Capacity
Headlamp HI (RH)	IPDM E/R	#51	10 A
Headlamp HI (LH)	IPDM E/R	#52	10 A

Is the fuse fusing?

YES >> GO TO 4.

NO >> Replace IPDM E/R.

4.CHECK HEADLAMP HIGH (HI) SHORT CIRCUIT

1. Disconnect the IPDM E/R connector.
2. Check continuity between the IPDM E/R harness connector terminal and the ground.

IPDM E/R		Ground	Continuity
Connector	Terminal		
RH	E15		Not existed
LH			

Does continuity exist?

YES >> Repair the harnesses or connectors. And then replace the fuse.

NO >> Replace the fuse. (Replace IPDM E/R if the fuse is fusing again.)

5.CHECK HEADLAMP (HI) GROUND OPEN CIRCUIT

Check continuity between the headlamp harness connector and the ground.

Headlamp		Ground	Continuity
Connector	Terminal		
RH	E45		Existed
LH	E26		

Does continuity exist?

YES >> Replace the headlamp (HI) bulb.

NO >> Repair the harnesses or connectors.

6.CHECK HEADLAMP (HI) GROUND OPEN CIRCUIT (LH)

Check continuity between the headlamp LH harness connector and the ground.

Headlamp		Ground	Continuity
Connector	Terminal		
LH	E26		Existed
	2		

Does continuity exist?

HEADLAMP (HI) CIRCUIT

< DTC/CIRCUIT DIAGNOSIS >

- YES >> GO TO 7.
NO >> Repair the harnesses or connectors.

7. CHECK CONTINUITY BETWEEN HEADLAMP HIGH (RH) AND DAYTIME RUNNING LIGHT RELAY-1

1. Remove the daytime running light relay-1.
2. Check continuity between the headlamp RH harness connector and the daytime running light relay-1 harness connector.

Headlamp		Daytime running light relay-1		Continuity
Connector	Terminal	Connector	Terminal	Existed
RH	E45	E57	1	

Does continuity exist?

- YES >> GO TO 8.
NO >> Repair the harness or connector.

8. CHECK THE DAYTIME RUNNING LIGHT RELAY-1 GROUND OPEN CIRCUIT

Check continuity between the daytime running light relay-1 harness connector and the ground.

Daytime running light relay-1		Ground	Continuity
Connector	Terminal		Existed
E57	4		

Does continuity exist?

- YES >> GO TO 9.
NO >> Repair the harness or connector.

9. CHECK THE DAYTIME RUNNING LIGHT RELAY-1

Check the daytime running light relay-1. Refer to [EXL-58, "Component Inspection \(Daytime Running Light Relay-1\)"](#).

Is the daytime running light relay-1 normal?

- YES >> Replace the headlamp (HI) bulb.
NO >> Replace the daytime running light relay-1.

A
B
C
D
E
F
G
H
I
J
K
M
N
O
P

EXL

HEADLAMP (LO) CIRCUIT

< DTC/CIRCUIT DIAGNOSIS >

HEADLAMP (LO) CIRCUIT

Component Function Check

INFOID:000000004991968

1. CHECK HEADLAMP (LO) OPERATION

IPDM E/R AUTO ACTIVE TEST

1. Start IPDM E/R auto active test. Refer to [EXL-32, "Diagnosis Description"](#).
2. Check that the headlamp is turned ON.

CONSULT-III ACTIVE TEST

1. Select "EXTERNAL LAMPS" of IPDM E/R active test item.
2. With operating the test items, check that the headlamp (LO) is turned ON.

Lo : Headlamp (LO) ON

Off : Headlamp (LO) OFF

Is the headlamp (LO) turned ON?

YES >> Headlamp (LO) is normal.

NO (With daytime running light system)>>Refer to [EXL-50, "WITH DAYTIME RUNNING LIGHT SYSTEM : Diagnosis Procedure"](#).

NO (Without daytime running light system)>>Refer to [EXL-53, "WITHOUT DAYTIME RUNNING LIGHT SYSTEM : Diagnosis Procedure"](#).

WITH DAYTIME RUNNING LIGHT SYSTEM

WITH DAYTIME RUNNING LIGHT SYSTEM : Diagnosis Procedure

INFOID:000000005136764

1. CHECK HEADLAMP LOW (LH) OUTPUT VOLTAGE

CONSULT-III ACTIVE TEST

1. Turn the ignition switch OFF.
2. Disconnect the headlamp LH connector.
3. Turn the ignition switch ON.
4. Select "EXTERNAL LAMPS" of IPDM E/R active test item.
5. With operating the test items, check the voltage between the IPDM E/R harness connector and the ground.

Terminals		Test item	Voltage (Approx.)
(+)	(-)		
IPDM E/R		EXTERNAL LAMPS	Battery voltage
Connector	Terminal		
E15	51	Lo	Battery voltage
		Off	0 V

Is the measurement value normal?

YES >> GO TO 2.

NO >> GO TO 8.

2. CHECK HEADLAMP LOW (RH) OUTPUT VOLTAGE

CONSULT-III ACTIVE TEST

1. Turn the ignition switch OFF.
2. Remove the daytime running light relay-2.
3. Turn the ignition switch ON.
4. Select "EXTERNAL LAMPS" of IPDM E/R active test item.
5. With operating the test items, check the voltage between the IPDM E/R harness connector and the ground.

HEADLAMP (LO) CIRCUIT

< DTC/CIRCUIT DIAGNOSIS >

Terminals		Test item	Voltage (Approx.)
(+)	(-)		
IPDM E/R		EXTERNAL LAMPS	Battery voltage
Connector	Terminal		
E15	52	Ground	Lo
			Off

Is the measurement value normal?

YES >> GO TO 3.

NO >> GO TO 8.

3. CHECK HEADLAMP LOW (LH) OPEN CIRCUIT

1. Turn the ignition switch OFF.
2. Disconnect the IPDM E/R connector.
3. Check continuity between the IPDM E/R harness connector and the headlamp LH harness connector.

IPDM E/R		Headlamp LH		Continuity
Connector	Terminal	Connector	Terminal	
E15	51	E26	3	Existed

Does continuity exist?

YES >> GO TO 4.

NO >> Repair the harnesses or connectors.

4. CHECK CONTINUITY BETWEEN IPDM E/R AND THE DAYTIME RUNNING LIGHT RELAY-2

1. Turn the ignition switch OFF.
2. Disconnect the IPDM E/R connector.
3. Check continuity between the IPDM E/R harness connector and the daytime running light relay-2 harness connector.

IPDM E/R		Daytime running light relay-2		Continuity
Connector	Terminal	Connector	Terminal	
E15	52	E59	2	Existed
			5	

Does continuity exist?

YES >> GO TO 5.

NO >> Repair the harnesses or connectors.

5. CHECK THE DAYTIME RUNNING LIGHT RELAY-2 GROUND OPEN CIRCUIT

Check continuity between the daytime running light relay-2 harness connector and the ground.

Daytime running light relay-2		Ground	Continuity
Connector	Terminal		
E59	1	Ground	Existed

Does continuity exist?

YES >> GO TO 6.

NO >> Repair the harnesses or connectors.

6. CHECK CONTINUITY BETWEEN THE DAYTIME RUNNING LIGHT RELAY-2 AND HEADLAMP RH

1. Turn the ignition switch OFF.
2. Disconnect the headlamp RH connector.
3. Check continuity between the daytime running light relay-2 harness connector and the headlamp RH harness connector.

A
B
C
D
E
F
G
H
I
J
K
L
M
N
O
P

EXL

HEADLAMP (LO) CIRCUIT

< DTC/CIRCUIT DIAGNOSIS >

Daytime running light relay-2		Headlamp RH		Continuity
Connector	Terminal	Connector	Terminal	
E59	3	E45	3	Existed

Does continuity exist?

- YES >> GO TO 7.
NO >> Repair the harnesses or connectors.

7.CHECK THE DAYTIME RUNNING LIGHT RELAY-2

Check the daytime running light relay-2. Refer to [EXL-59, "Component Inspection \(Daytime Running Light Relay-2\)"](#).

Is the daytime running light relay-2 normal?

- YES >> GO TO 10.
NO >> Replace the daytime running light relay-2.

8.CHECK HEADLAMP (LO) FUSE

1. Turn the ignition switch OFF.
2. Check that the following fuses are not fusing.

Unit	Location	Fuse No.	Capacity
Headlamp LO (LH)	IPDM E/R	#53	10 A
Headlamp LO (RH)	IPDM E/R	#54	10 A

Is the fuse fusing?

- YES >> GO TO 9.
NO >> Replace IPDM E/R.

9.CHECK HEADLAMP (LO) SHORT CIRCUIT

1. Disconnect the IPDM E/R connector.
2. Check continuity between the IPDM E/R harness connector terminal and the ground.

IPDM E/R			Ground	Continuity
Connector	Terminal			
LH	E15	51		Not existed
RH		52		

Does continuity exist?

- YES >> Repair the harnesses or connectors. And then replace the fuse.
NO >> Replace the fuse. (Replace IPDM E/R if the fuse is fusing again.)

10.CHECK HEADLAMP (LO) GROUND OPEN CIRCUIT (LH)

Check continuity between the headlamp LH harness connector and the ground.

Headlamp RH			Ground	Continuity
Connector	Terminal			
LH	E26	2		Existed

Does continuity exist?

- YES >> GO TO 11.
NO >> Repair the harnesses or connectors.

11.CHECK CONTINUITY BETWEEN HEADLAMP LOW (RH) AND DAYTIME RUNNING LIGHT RELAY-1

1. Remove the daytime running light relay-1.
2. Check continuity between the headlamp RH harness connector and the daytime running light relay-1 harness connector.

HEADLAMP (LO) CIRCUIT

< DTC/CIRCUIT DIAGNOSIS >

Headlamp RH		Daytime running light relay-1		Continuity
Connector	Terminal	Connector	Terminal	Existed
RH	E45	2	E57	

Does continuity exist?

- YES >> GO TO 12.
 NO >> Repair the harness or connector.

12.CHECK THE DAYTIME RUNNING LIGHT RELAY-1 GROUND OPEN CIRCUIT

Check continuity between the daytime running light relay-1 harness connector and the ground.

Daytime running light relay-1		Ground	Continuity
Connector	Terminal		Existed
E57	4		

Does continuity exist?

- YES >> GO TO 13.
 NO >> Repair the harness or connector.

13.CHECK THE DAYTIME RUNNING LIGHT RELAY-1

Check the daytime running light relay-1. Refer to [EXL-58. "Component Inspection \(Daytime Running Light Relay-1\)"](#).

Is the daytime running light relay-1 normal?

- YES >> Replace the headlamp (LO) bulb. (Bulb socket is abnormally.)
 NO >> Replace the daytime running light relay-1.

WITHOUT DAYTIME RUNNING LIGHT SYSTEM

WITHOUT DAYTIME RUNNING LIGHT SYSTEM : Diagnosis Procedure

INFOID:000000005136766

1.CHECK HEADLAMP (LO) OUTPUT VOLTAGE

CONSULT-III ACTIVE TEST

- Turn the ignition switch OFF.
- Disconnect the headlamp connector.
- Turn the ignition switch ON.
- Select "EXTERNAL LAMPS" of IPDM E/R active test item.
- With operating the test items, check the voltage between the IPDM E/R harness connector and the ground.

Terminals			Test item	Voltage (Approx.)
(+)		(-)		
IPDM E/R			EXTERNAL LAMPS	Battery voltage
Connector	Terminal			
RH	E15	52	Lo	0 V
LH		51	Lo	Battery voltage
			Off	0 V

Is the measurement value normal?

- YES >> GO TO 2.
 NO >> GO TO 3.

2.CHECK HEADLAMP (LO) OPEN CIRCUIT

- Turn the ignition switch OFF.

HEADLAMP (LO) CIRCUIT

< DTC/CIRCUIT DIAGNOSIS >

2. Disconnect IPDM E/R connector.
3. Check continuity between the IPDM E/R harness connector and the headlamp harness connector.

IPDM E/R		Headlamp		Continuity
Connector	Terminal	Connector	Terminal	
RH	E15	52	E45	Existed
LH		51	E26	

Does continuity exist?

- YES >> GO TO 5.
 NO >> Repair the harnesses or connectors.

3.CHECK HEADLAMP (LO) FUSE

1. Turn the ignition switch OFF.
2. Check that the following fuses are not fusing.

Unit	Lotion	Fuse No.	Capacity
Headlamp LO (RH)	IPDM E/R	#54	15 A
Headlamp LO (LH)	IPDM E/R	#53	15 A

Is the fuse fusing?

- YES >> GO TO 4.
 NO >> Replace IPDM E/R.

4.CHECK HEADLAMP (LO) SHORT CIRCUIT

1. Disconnect the IPDM E/R connector.
2. Check continuity between the IPDM E/R harness connector and the ground.

IPDM E/R		Ground	Continuity
Connector	Terminal		
RH	E15	52	Not existed
LH		51	

Does continuity exist?

- YES >> Repair the harnesses or connectors. And then replace the fuse.
 NO >> Replace the fuse. (Replace IPDM E/R if the fuse is fusing again.)

5.CHECK HEADLAMP (LO) GROUND OPEN CIRCUIT

Check continuity between the headlamp harness connector and the ground.

Headlamp		Ground	Continuity
Connector	Terminal		
RH	E45	2	Existed
LH	E26	2	

Does continuity exist?

- YES >> Replace the headlamp (LO) bulb. (Bulb socket is abnormally.)
 NO >> Repair the harnesses or connectors.

FRONT FOG LAMP CIRCUIT

< DTC/CIRCUIT DIAGNOSIS >

FRONT FOG LAMP CIRCUIT

Component Function Check

INFOID:000000004991971

1.CHECK FRONT FOG LAMP OPERATION

IPDM E/R AUTO ACTIVE TEST

1. Activate IPDM E/R auto active test. Refer to [EXL-32, "Diagnosis Description"](#).
2. Check that the front fog lamp is turned ON.

CONSULT-III ACTIVE TEST

1. Select "EXTERNAL LAMPS" of IPDM E/R active test item.
2. With operating the test items, check that the front fog lamp is turned ON.

Fog : Front fog lamp ON
Off : Front fog lamp OFF

Is the front fog lamp turned ON?

- YES >> Front fog lamp circuit is normal.
NO >> Refer to [EXL-55, "Diagnosis Procedure"](#).

Diagnosis Procedure

INFOID:000000004991972

1.CHECK FRONT FOG LAMP FUSE

1. Turn the ignition switch OFF.
2. Check that the following fuse is not fusing.

Unit	Location	Fuse No.	Capacity
Front fog lamp	IPDM E/R	#50	15 A

Is the fuse fusing?

- YES >> GO TO 2.
NO >> GO TO 3.

2.CHECK FRONT FOG LAMP SHORT CIRCUIT

1. Disconnect IPDM E/R connector and the front fog connector.
2. Check continuity between the IPDM E/R harness connector and the ground.

IPDM E/R		Ground	Continuity
Connector	Terminal		
RH	E12	21	Not existed
LH		22	

Does continuity exist?

- YES >> Repair the harnesses or connectors. And then replace the fuse.
NO >> Replace the fuse. (Replace IPDM E/R if the fuse is fusing again.)

3.CHECK FRONT FOG LAMP BULB

Check the applicable lamp bulb.

Is the bulb normal?

- YES >> GO TO 4.
NO >> Replace the bulb.

4.CHECK FRONT FOG LAMP OUTPUT VOLTAGE

CONSULT-III ACTIVE TEST

1. Disconnect the front fog lamp connector.
2. Turn the ignition switch ON.
3. Select "EXTERNAL LAMPS" of IPDM E/R active test item.

FRONT FOG LAMP CIRCUIT

< DTC/CIRCUIT DIAGNOSIS >

4. With operating the test items, check the voltage between the IPDM E/R harness connector and the ground.

Terminals			Test item	Voltage (Approx.)
(+)		(-)		
IPDM E/R			EXTERNAL LAMPS	Battery voltage
Connector	Terminal			
RH	E12	21	Fog	0 V
LH		22	Fog	Battery voltage
			Off	0 V

Is the measurement value normal?

YES >> GO TO 5.

NO >> Replace IPDM E/R.

5. CHECK FRONT FOG LAMP OPEN CIRCUIT

- Turn the ignition switch OFF.
- Disconnect IPDM E/R connector.
- Check continuity between the IPDM E/R harness connector and the front fog lamp harness connector.

IPDM E/R			Front fog lamp		Continuity
Connector	Terminal		Connector	Terminal	
RH	E12	21	E48	1	Existed
LH		22	E30	1	

Does continuity exist?

YES >> GO TO 6.

NO >> Repair the harnesses or connectors.

6. CHECK FRONT FOG LAMP GROUND CIRCUIT OPEN CIRCUIT

Check continuity between the front fog lamp harness connector and the ground.

Front fog lamp			Ground	Continuity
Connector	Terminal			
RH	E48	2	Ground	Existed
LH	E30	2		

Does continuity exist?

YES >> Replace the front fog lamp.

NO >> Repair the harnesses or connectors.

DAYTIME RUNNING LIGHT RELAY CIRCUIT

< DTC/CIRCUIT DIAGNOSIS >

DAYTIME RUNNING LIGHT RELAY CIRCUIT

Component Function Check

INFOID:000000005144556

NOTE:

Check the headlamp (HI) circuit if the headlamp (HI) is not turned ON. Refer to [EXL-47, "Component Function Check"](#).

CAUTION:

Before performing the diagnosis, check that the headlamp (HI) bulb is normal.

1.CHECK DAYTIME RUNNING LIGHT OPERATION

CONSULT-III ACTIVE TEST

1. Select "DAYTIME RUNNING LIGHT" of BCM (HEADLAMP) active test item.
2. With operating the test items, check that daytime running light operation.

On : Daytime running light ON

Off : Daytime running light OFF

Is the daytime running light turned ON/OFF?

YES >> Daytime running light relay-1 circuit is normal.

NO >> Refer to [EXL-57, "Diagnosis Procedure"](#).

Diagnosis Procedure

INFOID:000000005144666

1.CHECK DAYTIME RUNNING LIGHT RELAY FUSE

Check that the following fuse is not fusing.

Unit	Location	Fuse No.	Capacity
Daytime running light relay-1	Fuse and fusible link block	#32	10A

Is the fuse fusing?

YES >> Replace the fuse after repairing the applicable circuit.

NO >> GO TO 2.

2.CHECK DAYTIME RUNNING LIGHT RELAY-1 POWER SUPPLY

1. Remove daytime running light relay-1.
2. Check voltage between daytime running light relay-1 harness connector and the ground.

Terminals		Voltage (Approx.)
(+)	(-)	
Daytime running light relay-1	Ground	Voltage (Approx.)
Connector		
E57		2
	5	

Is the measurement value normal?

YES >> GO TO 3.

NO >> Repair harnesses or connectors.

3.CHECK DAYTIME RUNNING LIGHT RELAY-1

Check daytime running light relay-1. Refer to [EXL-58, "Component Inspection \(Daytime Running Light Relay-1\)"](#).

Is the daytime running light relay-1 normal?

YES >> GO TO 4.

NO >> Replace daytime running light relay-1.

4.CHECK DAYTIME RUNNING LIGHT RELAY-1 CONTROL SIGNAL OUTPUT

A
B
C
D
E
F
G
H
I
J
K
EXL
M
N
O
P

DAYTIME RUNNING LIGHT RELAY CIRCUIT

< DTC/CIRCUIT DIAGNOSIS >

ⓐCONSULT-III ACTIVE TEST

1. Turn the ignition switch OFF.
2. Install daytime running light relay-1.
3. Turn the ignition switch ON.
4. Select "DAYTIME RUNNING LIGHT" of BCM (HEAD LAMP) active test item.
5. With operating the test item, check voltage between IPDM E/R harness connector and the ground.

Terminals		Test item	Voltage (Approx.)
(+)	(-)		
IPDM E/R		DAYTIME RUNNING LIGHT	0 V
Connector	Terminal		
E13	28	On	0 V
		Off	Battery voltage

Is the measurement value normal?

YES >> Check daytime running light relay-1 circuit. Refer to [EXL-58, "Component Inspection \(Daytime Running Light Relay-1\)"](#).

Fixed at 0 V >> GO TO 5.

Fixed at battery voltage >> Replace IPDM E/R.

5.CHECK DAYTIME RUNNING LIGHT RELAY-1 CONTROL SIGNAL OPEN CIRCUIT

1. Remove daytime running light relay-1.
2. Disconnect IPDM E/R harness connector.
3. Check continuity between IPDM E/R harness connector and daytime running light relay-1 harness connector.

IPDM E/R		Daytime running light relay-1		Continuity
Connector	Terminal	Connector	Terminal	
E13	28	E57	1	Existed

Does continuity exist?

YES >> GO TO 6.

NO >> Repair the harnesses or connectors.

6.CHECK DAYTIME RUNNING LIGHT RELAY- CONTROL SIGNAL SHORT CIRCUIT

Check continuity between IPDM E/R harness connector and the ground.

IPDM E/R		Ground	Continuity
Connector	Terminal		
E13	28		Not existed

Does continuity exist?

YES >> Repair the harnesses or connectors.

NO >> Replace IPDM E/R.

Component Inspection (Daytime Running Light Relay-1)

INFOID:000000005144667

1.CHECK DAYTIME RUNNING LIGHT RELAY-1

1. Turn the ignition switch OFF.
2. Remove daytime running light relay-1.
3. Apply battery voltage to daytime running light relay- between terminals 1 and 2.
4. Check continuity of daytime running light relay-1.

DAYTIME RUNNING LIGHT RELAY CIRCUIT

< DTC/CIRCUIT DIAGNOSIS >

Daytime running light relay-1		Condition	Continuity
Terminal		Voltage	
5	3	Apply	Existed
		Not Apply	Not existed
4		Apply	Not existed
		Not Apply	Existed

Does continuity exist?

- YES >> Daytime running light relay-1 is normal.
 NO >> Replace daytime running light relay-1.

Component Inspection (Daytime Running Light Relay-2)

INFOID:000000005144676

1. CHECK DAYTIME RUNNING LIGHT RELAY-2

- Turn the ignition switch OFF.
- Disconnect daytime running light relay-2.
- Apply battery voltage to daytime running light relay-2 between terminals 1 and 2.
- Check continuity daytime running light of relay-2.

Daytime running light relay-1		Condition	Continuity
Terminal		Voltage	
3	5	Apply	Existed
		Not Apply	Not existed

Does continuity exist?

- YES >> Daytime running light relay-2 is normal.
 NO >> Replace Daytime running light relay-2.

A
B
C
D
E
F
G
H
I
J
K
EXL
M
N
O
P

EXL

PARKING LAMP CIRCUIT

< DTC/CIRCUIT DIAGNOSIS >

PARKING LAMP CIRCUIT

Component Function Check

INFOID:000000004991976

1.CHECK PARKING LAMP OPERATION

⊗IPDM E/R AUTO ACTIVE TEST

1. Activate IPDM E/R auto active test. Refer to [EXL-32, "Diagnosis Description"](#).
2. Check that the parking lamp is turned ON.

ⓅCONSULT-III ACTIVE TEST

1. Select "EXTERNAL LAMPS" of IPDM E/R active test item.
2. With operating the test items, check that the parking lamp is turned ON.

TAIL : Parking lamp ON
Off : Parking lamp OFF

Is the parking lamp turned ON?

- YES >> Parking lamp circuit is normal.
NO >> Refer to [EXL-60, "Diagnosis Procedure"](#).

Diagnosis Procedure

INFOID:000000004991977

1.CHECK PARKING LAMP FUSE

1. Turn the ignition switch OFF.
2. Check that the following fuses are not fusing.

Unit	Location	Fuse No.	Capacity
<ul style="list-style-type: none">• Parking lamp• License plate lamp• Side marker lamp• Tail lamp	IPDM E/R	#47	10 A

Is the fuse fusing?

- YES >> GO TO 2.
NO >> GO TO 3.

2.CHECK PARKING LAMP SHORT CIRCUIT

1. Disconnect IPDM E/R connector and the parking lamp connector.
2. Check continuity between the IPDM E/R harness connector and the ground.

IPDM E/R		Ground	Continuity
Connector	Terminal		
RH	E14	37	Not existed
LH		36	

Does continuity exist?

- YES >> Repair the harnesses or connectors. And then replace the fuse.
NO >> Replace the fuse. (Replace IPDM E/R if fusing is found again.)

3.CHECK PARKING LAMP BULB

Check the applicable lamp bulb.

Is the bulb normal?

- YES >> GO TO 4.
NO >> Replace the bulb.

4.CHECK PARKING LAMP OUTPUT VOLTAGE

ⓅCONSULT-III ACTIVE TEST

1. Disconnect the parking lamp connector.

PARKING LAMP CIRCUIT

< DTC/CIRCUIT DIAGNOSIS >

2. Turn the ignition switch ON.
3. Select "EXTERNAL LAMPS" of IPDM E/R active test item.
4. With operating the test items, check the voltage between the IPDM E/R harness connector and the ground.

Terminals			Test item	Voltage (Approx.)
(+)		(-)		
IPDM E/R			EXTERNAL LAMPS	Battery voltage
Connector	Terminal			
RH	E14	37	TAIL	0 V
LH		36	OFF	

Is the measurement value normal?

- YES >> GO TO 5.
 NO >> Replace IPDM E/R.

5. CHECK PARKING LAMP OPEN CIRCUIT

1. Turn the ignition switch OFF.
2. Disconnect IPDM E/R connector.
3. Check continuity between the IPDM E/R harness connector and the parking lamp harness connector.

IPDM E/R			Parking lamp		Continuity
Connector	Terminal		Connector	Terminal	
RH	E14	37	E43	1	Existed
LH		36	E24	1	

Does continuity exist?

- YES >> GO TO 6.
 NO >> Repair the harnesses or connectors.

6. CHECK PARKING LAMP GROUND OPEN CIRCUIT

Check continuity between the parking lamp harness connector and the ground.

Parking lamp			Ground	Continuity
Connector	Terminal			
RH	E43	2	Ground	Existed
LH	E24	2		

Does continuity exist?

- YES >> Replace the front combination lamp.
 NO >> Repair the harnesses or connectors.

A
B
C
D
E
F
G
H
I
J
K
L
M
N
O
P

EXL

TURN SIGNAL LAMP CIRCUIT

< DTC/CIRCUIT DIAGNOSIS >

TURN SIGNAL LAMP CIRCUIT

Description

INFOID:000000004991980

BCM performs the high flasher operation (fail-safe) if any bulb or harness of the turn signal lamp circuit is open.

NOTE:

The turn signal lamp blinks at normal speed when using the hazard warning lamp.

Component Function Check

INFOID:000000004991981

1. CHECK TURN SIGNAL LAMP

ⓅCONSULT-III ACTIVE TEST

1. Select "FLASHER" of BCM (FLASHER) active test item.
2. With operating the test items, check that the turn signal lamps blink.

LH : Turn signal lamps (LH) blink
RH : Turn signal lamps (RH) blink
Off : Turn signal lamps OFF

Does the turn signal lamps blink?

- YES >> Turn signal lamp circuit is normal.
NO >> Refer to [EXL-62. "Diagnosis Procedure"](#).

Diagnosis Procedure

INFOID:000000004991982

1. CHECK TURN SIGNAL LAMP BULB

Check the applicable lamp bulb.

Is the bulb normal?

- YES >> GO TO 2.
NO >> Replace the bulb.

2. CHECK TURN SIGNAL LAMP OPEN CIRCUIT

1. Turn the ignition switch OFF.
2. Disconnect BCM connector.
3. Disconnect the front turn signal lamp connector, side turn signal lamp connector, or the rear combination lamp connector.
4. Check continuity between the BCM harness connector and the front turn signal lamp, side turn signal lamp or the rear combination lamp harness connector.

Front turn signal lamp

BCM		Front turn signal lamp		Continuity
Connector	Terminal	Connector	Terminal	
RH	M67	61	E46	Existed
LH		60	E27	

Side turn signal lamp

BCM		Side turn signal lamp		Continuity
Connector	Terminal	Connector	Terminal	
RH	M67	61	E40	Existed
LH		60	E23	

TURN SIGNAL LAMP CIRCUIT

< DTC/CIRCUIT DIAGNOSIS >

Rear turn signal lamp

BCM		Rear combination lamp		Continuity
Connector	Terminal	Connector	Terminal	
RH	M67	61	B59	Existed
LH		60	B80	

Does continuity exist?

YES >> GO TO 3.

NO >> Repair the harnesses or connectors.

3.CHECK TURN SIGNAL LAMP SHORT CIRCUIT

Check continuity between the BCM harness connector and the ground.

BCM		Ground	Continuity
Connector	Terminal		
RH	M67	61	Not existed
LH		60	

Does continuity exist?

YES >> Repair the harnesses or connectors.

NO >> GO TO 4.

4.CHECK TURN SIGNAL LAMP GROUND OPEN CIRCUIT

Check continuity between the BCM harness connector and the front turn signal lamp, side turn signal lamp or the rear combination lamp and the ground.

Front turn signal lamp

Front turn signal lamp		Ground	Continuity
Connector	Terminal		
RH	E46	2	Existed
LH	E27		

Side turn signal lamp

Side turn signal lamp		Ground	Continuity
Connector	Terminal		
RH	E40	2	Existed
LH	E23		

Rear turn signal lamp

Rear combination lamp		Ground	Continuity
Connector	Terminal		
RH	B59	3	Existed
LH	B80		

Does continuity exist?

YES >> Replace BCM.

NO >> Repair the harnesses or connectors.

A
B
C
D
E
F
G
H
I
J
K
M
N
O
P

EXL

OPTICAL SENSOR

< DTC/CIRCUIT DIAGNOSIS >

OPTICAL SENSOR

Description

INFOID:000000004992158

Optical sensor converts the outside brightness (lux) to voltage and transmits the optical sensor signal to BCM.

Component Function Check

INFOID:000000004992159

1.CHECK OPTICAL SENSOR SIGNAL BY CONSULT-III

CONSULT-III DATA MONITOR

1. Turn the ignition switch ON.
2. Select "OPTISEN (DTCT)" of BCM (HEADLAMP) data monitor item.
3. Turn the lighting switch AUTO.
4. With the optical sensor illuminating, check the monitor status.

Monitor item	Condition		Voltage (Approx.)
OPTISEN (DTCT)	Optical sensor	When illuminating	3.1 V or more *
		When shutting off light	0.6 V or less

*: Illuminates the optical sensor. The value may be less than the standard value if brightness is weak.

Is the item status normal?

- YES >> Optical sensor is normal.
NO >> Refer to [EXL-64, "Diagnosis Procedure"](#).

Diagnosis Procedure

INFOID:000000004992160

1.CHECK OPTICAL SENSOR POWER SUPPLY INPUT

1. Turn the ignition switch ON.
2. Turn the lighting switch AUTO.
3. Check the voltage between the optical sensor harness connector and the ground.

Terminals			Voltage (Approx.)
(+)	(-)	Ground	
Optical sensor			5 V
Connector	Terminal	Ground	
M17	1		

Is the measurement value normal?

- YES >> GO TO 2.
NO >> GO TO 4.

2.CHECK OPTICAL SENSOR GROUND INPUT

Check the voltage between the optical sensor harness connector and the ground.

Terminals			Voltage (Approx.)
(+)	(-)	Ground	
Optical sensor			0 V
Connector	Terminal	Ground	
M17	3		

Is the measurement value normal?

- YES >> GO TO 3.
NO >> GO TO 6.

3.CHECK OPTICAL SENSOR SIGNAL OUTPUT

OPTICAL SENSOR

< DTC/CIRCUIT DIAGNOSIS >

With illuminating the optical sensor, check the voltage between the optical sensor harness connector and the ground.

Terminals		Condition	Voltage (Approx.)
(+)	(-)		
Optical sensor		Optical sensor	
Connector	Terminal		
M17	2	When illuminating	3.1 V or more *
		When shutting off light	0.6 V or less

*: Illuminate the optical sensor. The value may be less than the standard if brightness is weak.

Is the measurement value normal?

YES >> GO TO 7.

NO >> Replace the optical sensor.

4.CHECK OPTICAL SENSOR OPEN CIRCUIT

1. Turn the ignition switch OFF.
2. Disconnect the optical sensor connector and BCM connector.
3. Check continuity between the optical sensor harness connector and the BCM harness connector.

Optical sensor		BCM		Continuity
Connector	Terminal	Connector	Terminal	
M17	1	M68	17	Existed

Does continuity exist?

YES >> GO TO 5.

NO >> Repair the harnesses or connectors.

5.CHECK OPTICAL SENSOR SHORT CIRCUIT

Check the continuity between the optical sensor harness connector and the ground.

Optical sensor		Ground	Continuity
Connector	Terminal		
M17	1		Not existed

Does continuity exist?

YES >> Repair the harnesses or connectors.

NO >> Replace BCM.

6.CHECK OPTICAL SENSOR GROUND OPEN CIRCUIT

1. Turn the ignition switch OFF.
2. Disconnect the optical sensor connector and BCM connector.
3. Check continuity between the optical sensor harness connector and the BCM harness connector.

Optical sensor		BCM		Continuity
Connector	Terminal	Connector	Terminal	
M17	3	M68	18	Existed

Does continuity exist?

YES >> Replace BCM.

NO >> Repair the harnesses or connectors.

7.CHECK OPTICAL SENSOR SIGNAL OPEN CIRCUIT

1. Turn the ignition switch OFF.
2. Disconnect the optical sensor connector and BCM connector.
3. Check continuity between the optical sensor harness connector and the BCM harness connector.

A
B
C
D
E
F
G
H
I
J
K
EXL
M
N
O
P

OPTICAL SENSOR

< DTC/CIRCUIT DIAGNOSIS >

Optical sensor		BCM		Continuity
Connector	Terminal	Connector	Terminal	
M17	2	M68	14	Existed

Does continuity exist?

YES >> GO TO 8.

NO >> Repair the harnesses or connectors.

8.CHECK OPTICAL SENSOR SHORT CIRCUIT

Check the continuity between the optical sensor harness connector and the ground.

Optical sensor		Ground	Continuity
Connector	Terminal		
M17	2		Not existed

Does continuity exist?

YES >> Repair the harnesses or connectors.

NO >> Replace BCM.

HAZARD SWITCH

< DTC/CIRCUIT DIAGNOSIS >

HAZARD SWITCH

Component Function Check

INFOID:000000004991986

1.CHECK HAZARD SWITCH SIGNAL BY CONSULT-III

CONSULT-III DATA MONITOR

- Turn the ignition switch ON.
- Select "HAZARD SW" of BCM (FLASHER) data monitor item.
- With operating the hazard switch, check the monitor status.

Monitor item	Condition		Monitor status
HAZARD SW	Hazard switch	ON	On
		OFF	Off

Is the item status normal?

- YES >> Hazard switch circuit is normal.
 NO >> Refer to [EXL-67, "Diagnosis Procedure"](#).

Diagnosis Procedure

INFOID:000000004991987

1.CHECK HAZARD SWITCH SIGNAL INPUT

With operating the hazard switch, check the voltage between the BCM harness connector and the ground.

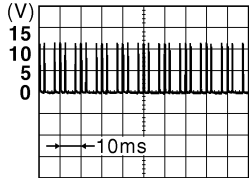
Terminals		Condition	Voltage (Approx.)
(+)	(-)		
BCM		Hazard switch	0 V
Connector	Terminal		
M68	29	ON	
		OFF	
		Ground	

JPMIA0154GB

Is the measurement value normal?

- YES >> Replace BCM. Refer to [BCS-148, "Exploded View"](#).
 NO >> GO TO 2.

2.CHECK HAZARD SWITCH SIGNAL OPEN CIRCUIT

- Turn the ignition switch OFF.
- Disconnect the hazard switch connector and BCM connector.
- Check continuity between the hazard switch harness connector and the BCM harness connector.

Hazard switch		BCM		Continuity
Connector	Terminal	Connector	Terminal	
M45	2	M68	29	Existed

Does continuity exist?

- YES >> GO TO 3.
 NO >> Repair the harnesses or connectors.

3.CHECK HAZARD SWITCH SIGNAL SHORT CIRCUIT

Check continuity between the hazard switch harness connector and the ground.

HAZARD SWITCH

< DTC/CIRCUIT DIAGNOSIS >

Hazard switch		Ground	Continuity
Connector	Terminal		
M45	2		Not existed

Does continuity exist?

YES >> Repair the harnesses or connectors.

NO >> GO TO 4.

4.CHECK HAZARD SWITCH GROUND OPEN CIRCUIT

Check continuity between the hazard switch harness connector and the ground.

Hazard switch		Ground	Continuity
Connector	Terminal		
M45	1		Existed

Does continuity exist?

YES >> Replace the hazard switch.

NO >> Repair the harnesses or connectors.

TAIL LAMP CIRCUIT

< DTC/CIRCUIT DIAGNOSIS >

TAIL LAMP CIRCUIT

Component Function Check

INFOID:000000004991988

NOTE:

Check the parking lamp circuit if the parking lamp and the tail lamp are not turned ON.

1. CHECK TAIL LAMP OPERATION

IPDM E/R AUTO ACTIVE TEST

1. Activate IPDM E/R auto active test. Refer to [EXL-32, "Diagnosis Description"](#).
2. Check that the tail lamp is turned ON.

CONSULT-III ACTIVE TEST

1. Select "EXTERNAL LAMPS" of IPDM E/R active test item.
2. With operating the test items, check that the tail lamp is turned ON.

TAIL : Tail lamp ON

Off : Tail lamp OFF

Is the tail lamp turned ON?

YES >> Tail lamp circuit is normal.

NO >> Refer to [EXL-69, "Diagnosis Procedure"](#).

Diagnosis Procedure

INFOID:000000004991989

1. CHECK TAIL LAMP OUTPUT VOLTAGE

CONSULT-III ACTIVE TEST

1. Disconnect the rear combination lamp connector.
2. Turn the ignition switch ON.
3. Select "EXTERNAL LAMPS" of IPDM E/R active test item.
4. With operating the test items, check the voltage between the IPDM E/R harness connector and the ground.

Terminals			Test item	Voltage (Approx.)
(+)	(-)			
IPDM E/R			EXTERNAL LAMPS	Battery voltage
Connector	Terminal			
RH	E14	38	TAIL	Battery voltage
				Off
LH		41	TAIL	Battery voltage
			Off	0 V

Is the measurement value normal?

YES >> GO TO 2.

NO >> Replace IPDM E/R.

2. CHECK TAIL LAMP OPEN CIRCUIT

1. Turn the ignition switch OFF.
2. Disconnect IPDM E/R connector.
3. Check continuity between the IPDM E/R harness connector and the rear combination lamp harness connector.

TAIL LAMP CIRCUIT

< DTC/CIRCUIT DIAGNOSIS >

IPDM E/R		Rear combination lamp		Continuity
Connector	Terminal	Connector	Terminal	
RH	E14	38	B59	Existed
LH		41	B80	

Does continuity exist?

YES >> GO TO 3.

NO >> Repair the harnesses or connectors.

3. CHECK TAIL LAMP GROUND OPEN CIRCUIT

Check continuity between the rear combination lamp harness connector and the ground.

Rear combination lamp			Ground	Continuity
Connector	Terminal			
RH	B59	3		Existed
LH	B80	3		

Does continuity exist?

YES >> Replace the rear combination lamp.

NO >> Repair the harnesses or connectors.

REAR SIDE MARKER LAMP CIRCUIT

< DTC/CIRCUIT DIAGNOSIS >

REAR SIDE MARKER LAMP CIRCUIT

Component Function Check

INFOID:000000004992211

NOTE:

Check the parking lamp circuit if the parking lamp and the rear side marker lamp are not turned ON.

1. CHECK REAR SIDE MARKER LAMP OPERATION

⊗ IPDM E/R AUTO ACTIVE TEST

1. Activate IPDM E/R auto active test. Refer to [EXL-32, "Diagnosis Description"](#).
2. Check that the rear side marker lamp is turned ON.

Ⓜ CONSULT-III ACTIVE TEST

1. Select "EXTERNAL LAMPS" of IPDM E/R active test item.
2. With operating the test items, check that the rear side marker lamp is turned ON.

TAIL : Rear side marker lamp ON

Off : Rear side marker lamp OFF

Is the rear side marker lamp turned ON/OFF?

- YES >> Rear side marker lamp circuit is normal.
 NO >> Refer to [EXL-71, "Diagnosis Procedure"](#).

Diagnosis Procedure

INFOID:000000004992212

1. CHECK REAR SIDE MARKER LAMP BULB

Check the applicable lamp bulb.

Is the bulb normal?

- YES >> GO TO 2.
 NO >> Replace the bulb.

2. CHECK REAR SIDE MARKER LAMP OPEN CIRCUIT

1. Turn the ignition switch OFF.
2. Disconnect IPDM E/R connector and the rear side marker lamp connector.
3. Check continuity between the IPDM E/R harness connector and the rear side marker lamp harness connector.

IPDM E/R		Rear side marker lamp		Continuity
Connector	Terminal	Connector	Terminal	
RH	E14	41	T5	Existed
LH			T4	

Does continuity exist?

- YES >> GO TO 3.
 NO >> Repair the harnesses or connectors.

3. CHECK REAR SIDE MARKER LAMP GROUND OPEN CIRCUIT

Check continuity between the rear side marker lamp harness connector and the ground.

Rear side marker lamp			Ground	Continuity
Connector	Terminal			
RH	T5	1	Existed	
LH	T4	1		

Does continuity exist?

- YES >> Replace the rear side marker lamp assembly.
 NO >> Repair the harnesses or connectors.

A
B
C
D
E
F
G
H
I
J
K
M
N
O
P

EXL

LICENSE PLATE LAMP CIRCUIT

< DTC/CIRCUIT DIAGNOSIS >

LICENSE PLATE LAMP CIRCUIT

Component Function Check

INFOID:000000004991992

NOTE:

Check the parking lamp circuit if the parking lamp and the license plate lamp are not turned ON.

1. CHECK LICENSE PLATE LAMP OPERATION

⊗ IPDM E/R AUTO ACTIVE TEST

1. Activate IPDM E/R auto active test. Refer to [EXL-32, "Diagnosis Description"](#).
2. Check that the license plate lamp is turned ON.

Ⓟ CONSULT-III ACTIVE TEST

1. Select "EXTERNAL LAMPS" of IPDM E/R active test item.
2. With operating the lighting switch, check that the license plate lamp is turned ON.

TAIL : License plate lamp ON

Off : License plate lamp OFF

Is the license plate lamp turned ON?

- YES >> License plate lamp circuit is normal.
NO >> Refer to [EXL-72, "Diagnosis Procedure"](#).

Diagnosis Procedure

INFOID:000000004991993

1. CHECK LICENSE PLATE LAMP BULB

Check the applicable lamp bulb.

Is the bulb normal?

- YES >> GO TO 2.
NO >> Replace the bulb.

2. CHECK LICENSE PLATE LAMP OPEN CIRCUIT

1. Turn the ignition switch OFF.
2. Disconnect IPDM E/R connector and the license plate lamp connector.
3. Check continuity between the IPDM E/R harness connector and the license plate lamp harness connector.

IPDM E/R		License plate lamp		Continuity	
Connector	Terminal	Connector	Terminal		
RH	E14	41	T3	1	Existed
LH			T2	1	

Does continuity exist?

- YES >> GO TO 3.
NO >> Repair the harnesses or connectors.

3. CHECK LICENSE PLATE LAMP GROUND OPEN CIRCUIT

Check continuity between the license plate lamp harness connector and the ground.

License plate lamp			Ground	Continuity
Connector	Terminal			
RH	T3	2	Ground	Existed
LH	T2	2		

Does continuity exist?

- YES >> Replace the license plate lamp.
NO >> Repair the harnesses or connectors.

HEADLAMP SYSTEM

< DTC/CIRCUIT DIAGNOSIS >

HEADLAMP SYSTEM

Wiring Diagram - HEADLAMP -

INFOID:000000004991998

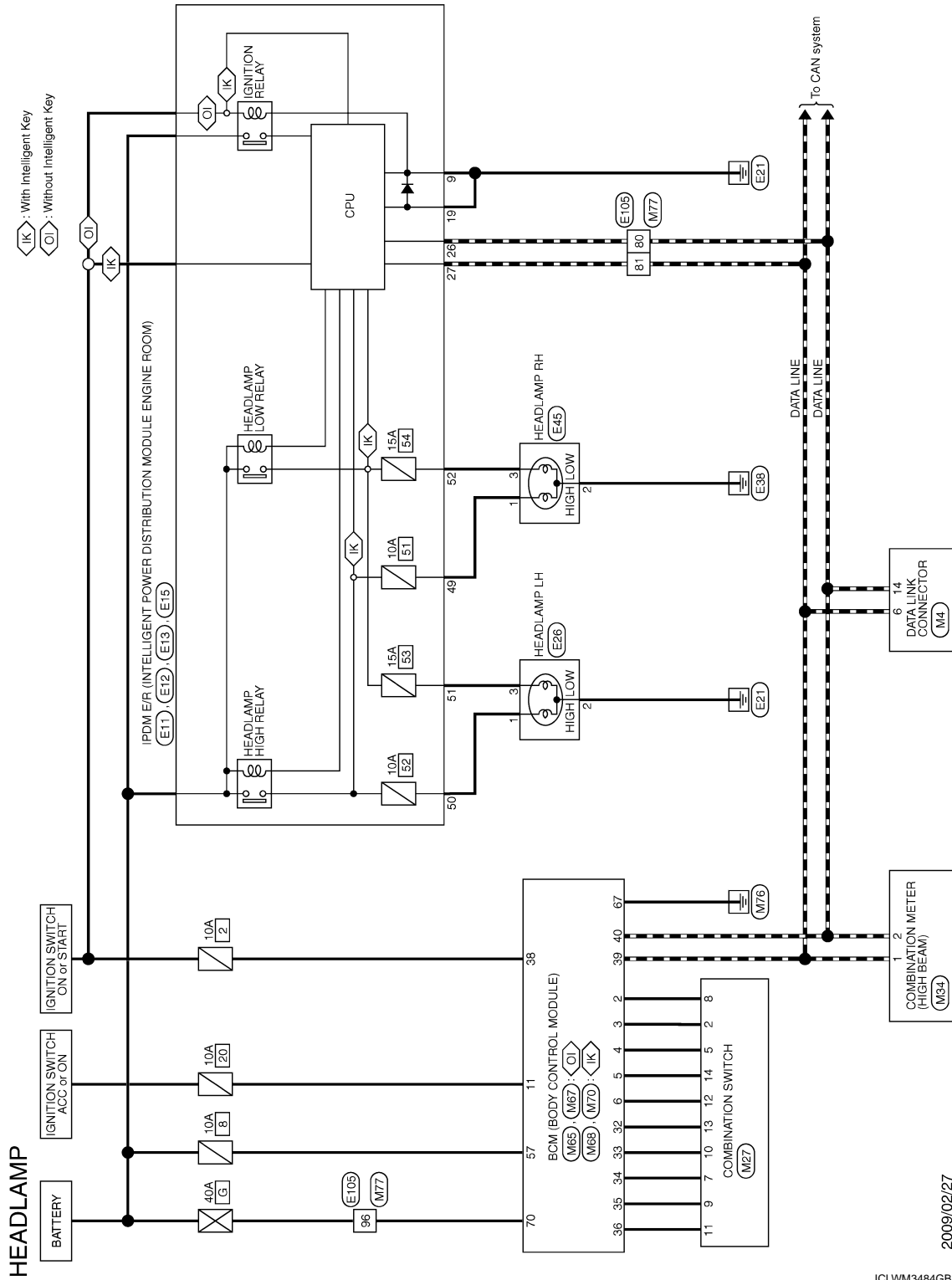

2009/02/27

JCLWM3484GB













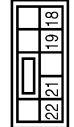

A
B
C
D
E
F
G
H
I
J
K
L
M
N
O
P

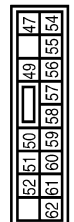
EXL

HEADLAMP SYSTEM

< DTC/CIRCUIT DIAGNOSIS >

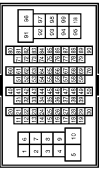
HEADLAMP

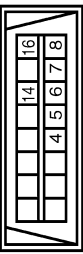
<table border="1"> <tr> <td>Connector No.</td> <td>E11</td> </tr> <tr> <td>Connector Name</td> <td>IPDM E/R (INTELLIGENT POWER DISTRIBUTION MODULE ENGINE ROOM)</td> </tr> <tr> <td>Connector Type</td> <td>MO8FB-LC</td> </tr> </table>   <table border="1"> <tr> <td>Terminal No.</td> <td>Color of Wire</td> <td>Signal Name [Specification]</td> </tr> <tr> <td>9</td> <td>B/W</td> <td>-</td> </tr> </table>	Connector No.	E11	Connector Name	IPDM E/R (INTELLIGENT POWER DISTRIBUTION MODULE ENGINE ROOM)	Connector Type	MO8FB-LC	Terminal No.	Color of Wire	Signal Name [Specification]	9	B/W	-	<table border="1"> <tr> <td>Connector No.</td> <td>E12</td> </tr> <tr> <td>Connector Name</td> <td>IPDM E/R (INTELLIGENT POWER DISTRIBUTION MODULE ENGINE ROOM)</td> </tr> <tr> <td>Connector Type</td> <td>NS08FB-CS</td> </tr> </table>   <table border="1"> <tr> <td>Terminal No.</td> <td>Color of Wire</td> <td>Signal Name [Specification]</td> </tr> <tr> <td>19</td> <td>B/W</td> <td>-</td> </tr> </table>	Connector No.	E12	Connector Name	IPDM E/R (INTELLIGENT POWER DISTRIBUTION MODULE ENGINE ROOM)	Connector Type	NS08FB-CS	Terminal No.	Color of Wire	Signal Name [Specification]	19	B/W	-	<table border="1"> <tr> <td>Connector No.</td> <td>E13</td> </tr> <tr> <td>Connector Name</td> <td>IPDM E/R (INTELLIGENT POWER DISTRIBUTION MODULE ENGINE ROOM)</td> </tr> <tr> <td>Connector Type</td> <td>TH12FW-RH</td> </tr> </table>   <table border="1"> <tr> <td>Terminal No.</td> <td>Color of Wire</td> <td>Signal Name [Specification]</td> </tr> <tr> <td>28</td> <td>P</td> <td>-</td> </tr> <tr> <td>27</td> <td>L</td> <td>-</td> </tr> </table>	Connector No.	E13	Connector Name	IPDM E/R (INTELLIGENT POWER DISTRIBUTION MODULE ENGINE ROOM)	Connector Type	TH12FW-RH	Terminal No.	Color of Wire	Signal Name [Specification]	28	P	-	27	L	-	<table border="1"> <tr> <td>Connector No.</td> <td>E15</td> </tr> <tr> <td>Connector Name</td> <td>IPDM E/R (INTELLIGENT POWER DISTRIBUTION MODULE ENGINE ROOM)</td> </tr> <tr> <td>Connector Type</td> <td>NS16FW-CS</td> </tr> </table>   <table border="1"> <tr> <td>Terminal No.</td> <td>Color of Wire</td> <td>Signal Name [Specification]</td> </tr> <tr> <td>49</td> <td>W</td> <td>-</td> </tr> <tr> <td>50</td> <td>GR</td> <td>-</td> </tr> <tr> <td>51</td> <td>R</td> <td>-</td> </tr> <tr> <td>52</td> <td>P</td> <td>-</td> </tr> </table>	Connector No.	E15	Connector Name	IPDM E/R (INTELLIGENT POWER DISTRIBUTION MODULE ENGINE ROOM)	Connector Type	NS16FW-CS	Terminal No.	Color of Wire	Signal Name [Specification]	49	W	-	50	GR	-	51	R	-	52	P	-									
Connector No.	E11																																																																							
Connector Name	IPDM E/R (INTELLIGENT POWER DISTRIBUTION MODULE ENGINE ROOM)																																																																							
Connector Type	MO8FB-LC																																																																							
Terminal No.	Color of Wire	Signal Name [Specification]																																																																						
9	B/W	-																																																																						
Connector No.	E12																																																																							
Connector Name	IPDM E/R (INTELLIGENT POWER DISTRIBUTION MODULE ENGINE ROOM)																																																																							
Connector Type	NS08FB-CS																																																																							
Terminal No.	Color of Wire	Signal Name [Specification]																																																																						
19	B/W	-																																																																						
Connector No.	E13																																																																							
Connector Name	IPDM E/R (INTELLIGENT POWER DISTRIBUTION MODULE ENGINE ROOM)																																																																							
Connector Type	TH12FW-RH																																																																							
Terminal No.	Color of Wire	Signal Name [Specification]																																																																						
28	P	-																																																																						
27	L	-																																																																						
Connector No.	E15																																																																							
Connector Name	IPDM E/R (INTELLIGENT POWER DISTRIBUTION MODULE ENGINE ROOM)																																																																							
Connector Type	NS16FW-CS																																																																							
Terminal No.	Color of Wire	Signal Name [Specification]																																																																						
49	W	-																																																																						
50	GR	-																																																																						
51	R	-																																																																						
52	P	-																																																																						
<table border="1"> <tr> <td>Connector No.</td> <td>E26</td> </tr> <tr> <td>Connector Name</td> <td>HEADLAMP LH</td> </tr> <tr> <td>Connector Type</td> <td>NO03FB</td> </tr> </table>   <table border="1"> <tr> <td>Terminal No.</td> <td>Color of Wire</td> <td>Signal Name [Specification]</td> </tr> <tr> <td>1</td> <td>GR</td> <td>-</td> </tr> <tr> <td>2</td> <td>B/R</td> <td>-</td> </tr> <tr> <td>3</td> <td>R</td> <td>-</td> </tr> </table>	Connector No.	E26	Connector Name	HEADLAMP LH	Connector Type	NO03FB	Terminal No.	Color of Wire	Signal Name [Specification]	1	GR	-	2	B/R	-	3	R	-	<table border="1"> <tr> <td>Connector No.</td> <td>E45</td> </tr> <tr> <td>Connector Name</td> <td>HEADLAMP RH</td> </tr> <tr> <td>Connector Type</td> <td>NO03FB</td> </tr> </table>   <table border="1"> <tr> <td>Terminal No.</td> <td>Color of Wire</td> <td>Signal Name [Specification]</td> </tr> <tr> <td>1</td> <td>W</td> <td>-</td> </tr> <tr> <td>2</td> <td>B/Y</td> <td>- [Without daytime running light system]</td> </tr> <tr> <td>3</td> <td>P</td> <td>- [Without daytime running light system]</td> </tr> </table>	Connector No.	E45	Connector Name	HEADLAMP RH	Connector Type	NO03FB	Terminal No.	Color of Wire	Signal Name [Specification]	1	W	-	2	B/Y	- [Without daytime running light system]	3	P	- [Without daytime running light system]	<table border="1"> <tr> <td>Connector No.</td> <td>E105</td> </tr> <tr> <td>Connector Name</td> <td>WIRE TO WIRE</td> </tr> <tr> <td>Connector Type</td> <td>TH80MW-CS (6-TM4)</td> </tr> </table>   <table border="1"> <tr> <td>Terminal No.</td> <td>Color of Wire</td> <td>Signal Name [Specification]</td> </tr> <tr> <td>80</td> <td>P</td> <td>-</td> </tr> <tr> <td>81</td> <td>L</td> <td>-</td> </tr> <tr> <td>98</td> <td>LG</td> <td>-</td> </tr> </table>	Connector No.	E105	Connector Name	WIRE TO WIRE	Connector Type	TH80MW-CS (6-TM4)	Terminal No.	Color of Wire	Signal Name [Specification]	80	P	-	81	L	-	98	LG	-	<table border="1"> <tr> <td>Connector No.</td> <td>M4</td> </tr> <tr> <td>Connector Name</td> <td>DATA LINK CONNECTOR</td> </tr> <tr> <td>Connector Type</td> <td>BD16FW</td> </tr> </table>   <table border="1"> <tr> <td>Terminal No.</td> <td>Color of Wire</td> <td>Signal Name [Specification]</td> </tr> <tr> <td>6</td> <td>L</td> <td>-</td> </tr> <tr> <td>14</td> <td>P</td> <td>-</td> </tr> </table>	Connector No.	M4	Connector Name	DATA LINK CONNECTOR	Connector Type	BD16FW	Terminal No.	Color of Wire	Signal Name [Specification]	6	L	-	14	P	-
Connector No.	E26																																																																							
Connector Name	HEADLAMP LH																																																																							
Connector Type	NO03FB																																																																							
Terminal No.	Color of Wire	Signal Name [Specification]																																																																						
1	GR	-																																																																						
2	B/R	-																																																																						
3	R	-																																																																						
Connector No.	E45																																																																							
Connector Name	HEADLAMP RH																																																																							
Connector Type	NO03FB																																																																							
Terminal No.	Color of Wire	Signal Name [Specification]																																																																						
1	W	-																																																																						
2	B/Y	- [Without daytime running light system]																																																																						
3	P	- [Without daytime running light system]																																																																						
Connector No.	E105																																																																							
Connector Name	WIRE TO WIRE																																																																							
Connector Type	TH80MW-CS (6-TM4)																																																																							
Terminal No.	Color of Wire	Signal Name [Specification]																																																																						
80	P	-																																																																						
81	L	-																																																																						
98	LG	-																																																																						
Connector No.	M4																																																																							
Connector Name	DATA LINK CONNECTOR																																																																							
Connector Type	BD16FW																																																																							
Terminal No.	Color of Wire	Signal Name [Specification]																																																																						
6	L	-																																																																						
14	P	-																																																																						

JCLWM3485GB

HEADLAMP SYSTEM

< DTC/CIRCUIT DIAGNOSIS >

HEADLAMP

Connector No.	M27
Connector Name	COMBINATION SWITCH
Connector Type	TH16FW-NH

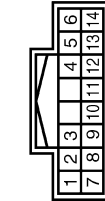

Terminal No.	Color of Wire	Signal Name [Specification]
2	GR	INPUT 4
5	L/Y	INPUT 3
7	W	OUTPUT 3
8	BR/W	INPUT 5
9	R/L	OUTPUT 2
10	Y/L	OUTPUT 4
11	L/O	OUTPUT 1
12	L/R	INPUT 1
13	LG	OUTPUT 5
14	G	INPUT 2

Connector No.	M67
Connector Name	BCM (BODY CONTROL MODULE) (WITHOUT INTELLIGENT KEY)
Connector Type	FEA09FB-FHA6-SA

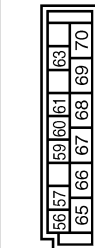

Terminal No.	Color of Wire	Signal Name [Specification]
57	Y	BAT (FUSE)
67	B	GND
70	Y	BAT (F/L)

Connector No.	M34
Connector Name	COMBINATION METER
Connector Type	TH40FB-NH

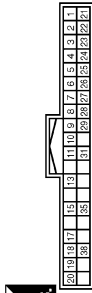

Terminal No.	Color of Wire	Signal Name [Specification]
1	L	CAN-H
2	P	CAN-L

Connector No.	M68
Connector Name	BCM (BODY CONTROL MODULE) (WITHOUT INTELLIGENT KEY)
Connector Type	TH40FB-NH

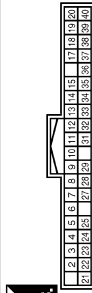

Terminal No.	Color of Wire	Signal Name [Specification]
2	BR/W	COMBI SW INPUT 5
3	GR	COMBI SW INPUT 4
4	L/Y	COMBI SW INPUT 3
5	G	COMBI SW INPUT 2
6	L/R	COMBI SW INPUT 1
11	L/Y	ACC F/B
32	LG	COMBI SW OUTPUT 5
33	Y/L	COMBI SW OUTPUT 4
34	W	COMBI SW OUTPUT 3
35	R/L	COMBI SW OUTPUT 2
36	L/O	COMBI SW OUTPUT 1

Connector No.	M65
Connector Name	BCM (BODY CONTROL MODULE) (WITHOUT INTELLIGENT KEY)
Connector Type	TH40FW-NH

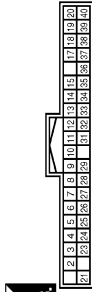

Terminal No.	Color of Wire	Signal Name [Specification]
2	BR/W	COMBI SW INPUT 5
3	GR	COMBI SW INPUT 4
4	L/Y	COMBI SW INPUT 3
5	G	COMBI SW INPUT 2
6	L/R	COMBI SW INPUT 1
11	L/Y	ACC
32	LG	COMBI SW OUTPUT 5
33	Y/L	COMBI SW OUTPUT 4
34	W	COMBI SW OUTPUT 3
35	R/L	COMBI SW OUTPUT 2
36	L/O	COMBI SW OUTPUT 1

Connector No.	M70
Connector Name	BCM (BODY CONTROL MODULE) (WITH INTELLIGENT KEY)
Connector Type	FEA09FB-FHA6-SA



Terminal No.	Color of Wire	Signal Name [Specification]
57	Y	BAT (FUSE)
67	B	GND
70	Y	BAT (F/L)

A
B
C
D
E
F
G
H
I
J
K
EXL
M
N
O
P

HEADLAMP SYSTEM

< DTC/CIRCUIT DIAGNOSIS >

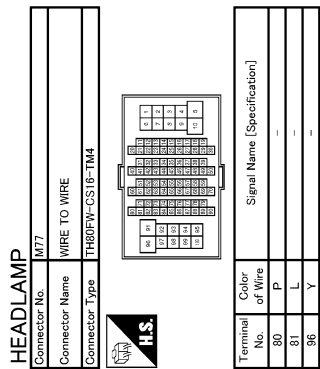

JCLWM3487GB

AUTO LIGHT SYSTEM

< DTC/CIRCUIT DIAGNOSIS >

AUTO LIGHT SYSTEM

Wiring Diagram - AUTO LIGHT SYSTEM -

INFOID:000000004992002

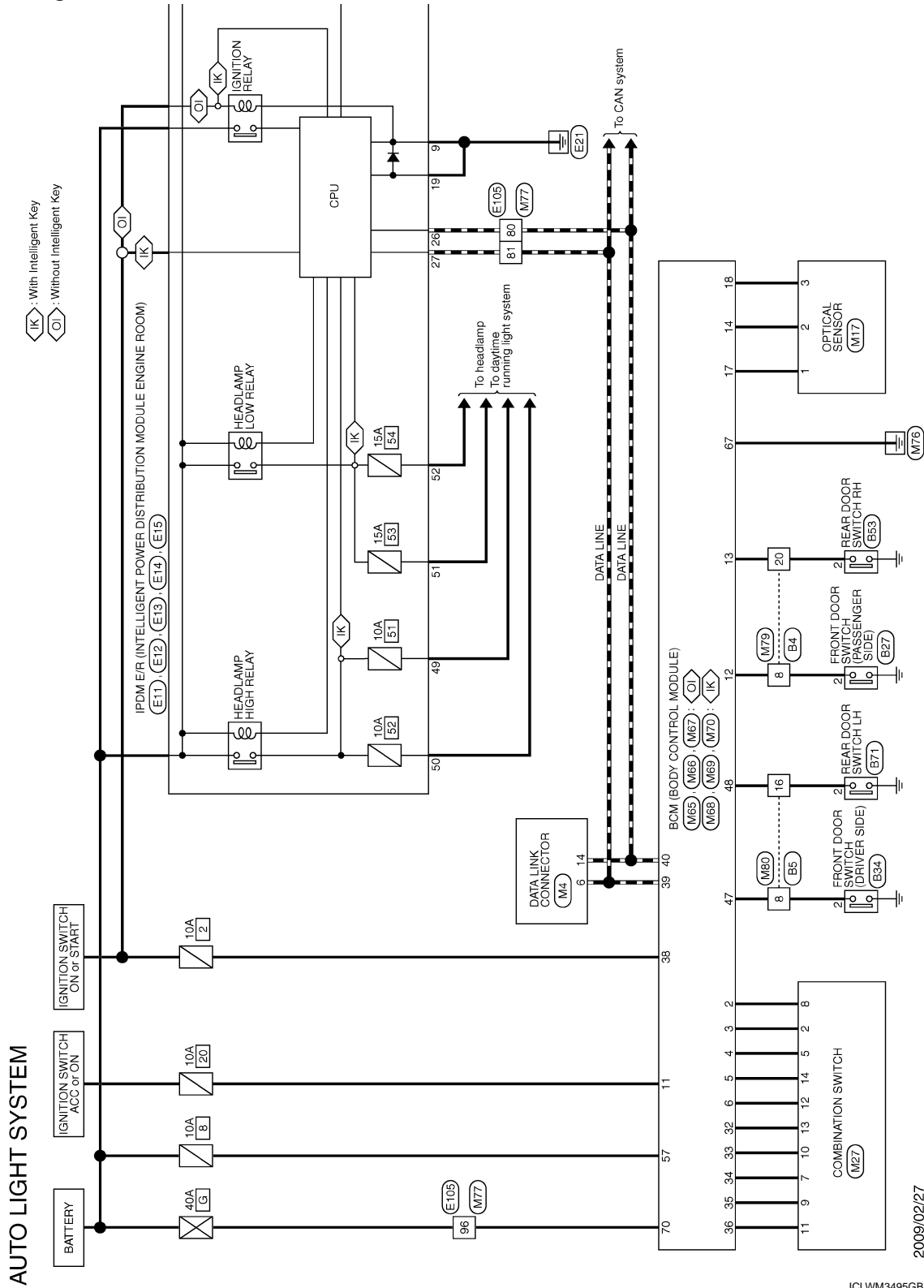

2009/02/27

JCLWM3495GB

A
B
C
D
E
F
G
H
I
J
K
L
M
N
O
P

EXL

AUTO LIGHT SYSTEM

< DTC/CIRCUIT DIAGNOSIS >

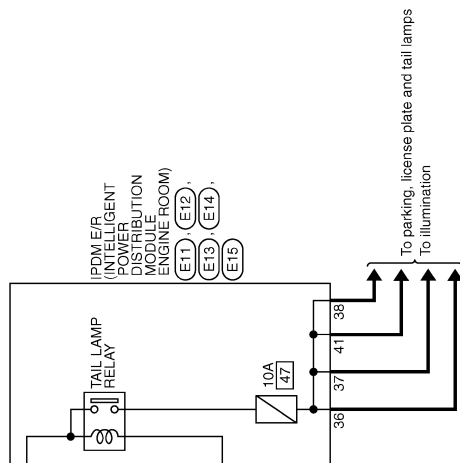





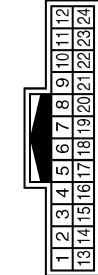
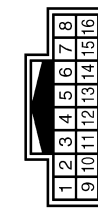

JCLWM3496GB

AUTO LIGHT SYSTEM

< DTC/CIRCUIT DIAGNOSIS >

AUTO LIGHT SYSTEM

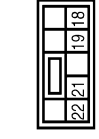
<table border="1" style="width: 100%; border-collapse: collapse;"> <tr><td>Connector No.</td><td>B4</td></tr> <tr><td>Connector Name</td><td>WIRE TO WIRE</td></tr> <tr><td>Connector Type</td><td>TH24WV-NH</td></tr> </table>  <table border="1" style="width: 100%; border-collapse: collapse;"> <tr><td>Terminal No.</td><td>8</td></tr> <tr><td>Color of Wire</td><td>SB</td></tr> <tr><td>Terminal No.</td><td>20</td></tr> <tr><td>Color of Wire</td><td>LG</td></tr> </table>	Connector No.	B4	Connector Name	WIRE TO WIRE	Connector Type	TH24WV-NH	Terminal No.	8	Color of Wire	SB	Terminal No.	20	Color of Wire	LG	<table border="1" style="width: 100%; border-collapse: collapse;"> <tr><td>Terminal No.</td><td>8</td></tr> <tr><td>Color of Wire</td><td>LG</td></tr> <tr><td>Terminal No.</td><td>16</td></tr> <tr><td>Color of Wire</td><td>W</td></tr> </table>	Terminal No.	8	Color of Wire	LG	Terminal No.	16	Color of Wire	W	<table border="1" style="width: 100%; border-collapse: collapse;"> <tr><td>Connector No.</td><td>B5</td></tr> <tr><td>Connector Name</td><td>WIRE TO WIRE</td></tr> <tr><td>Connector Type</td><td>TH16MP-NH</td></tr> </table>  <table border="1" style="width: 100%; border-collapse: collapse;"> <tr><td>Terminal No.</td><td>8</td></tr> <tr><td>Color of Wire</td><td>LG</td></tr> <tr><td>Terminal No.</td><td>16</td></tr> <tr><td>Color of Wire</td><td>W</td></tr> </table>	Connector No.	B5	Connector Name	WIRE TO WIRE	Connector Type	TH16MP-NH	Terminal No.	8	Color of Wire	LG	Terminal No.	16	Color of Wire	W	<table border="1" style="width: 100%; border-collapse: collapse;"> <tr><td>Terminal No.</td><td>8</td></tr> <tr><td>Color of Wire</td><td>LG</td></tr> <tr><td>Terminal No.</td><td>16</td></tr> <tr><td>Color of Wire</td><td>W</td></tr> </table>	Terminal No.	8	Color of Wire	LG	Terminal No.	16	Color of Wire	W	<table border="1" style="width: 100%; border-collapse: collapse;"> <tr><td>Connector No.</td><td>B27</td></tr> <tr><td>Connector Name</td><td>FRONT DOOR SWITCH (PASSENGER SIDE)</td></tr> <tr><td>Connector Type</td><td>A03FW</td></tr> </table>  <table border="1" style="width: 100%; border-collapse: collapse;"> <tr><td>Terminal No.</td><td>2</td></tr> <tr><td>Color of Wire</td><td>SB</td></tr> </table>	Connector No.	B27	Connector Name	FRONT DOOR SWITCH (PASSENGER SIDE)	Connector Type	A03FW	Terminal No.	2	Color of Wire	SB	<table border="1" style="width: 100%; border-collapse: collapse;"> <tr><td>Terminal No.</td><td>2</td></tr> <tr><td>Color of Wire</td><td>SB</td></tr> </table>	Terminal No.	2	Color of Wire	SB	<table border="1" style="width: 100%; border-collapse: collapse;"> <tr><td>Connector No.</td><td>B34</td></tr> <tr><td>Connector Name</td><td>FRONT DOOR SWITCH (DRIVER SIDE)</td></tr> <tr><td>Connector Type</td><td>A03FW</td></tr> </table>  <table border="1" style="width: 100%; border-collapse: collapse;"> <tr><td>Terminal No.</td><td>2</td></tr> <tr><td>Color of Wire</td><td>LG</td></tr> </table>	Connector No.	B34	Connector Name	FRONT DOOR SWITCH (DRIVER SIDE)	Connector Type	A03FW	Terminal No.	2	Color of Wire	LG	<table border="1" style="width: 100%; border-collapse: collapse;"> <tr><td>Terminal No.</td><td>2</td></tr> <tr><td>Color of Wire</td><td>LG</td></tr> </table>	Terminal No.	2	Color of Wire	LG	<table border="1" style="width: 100%; border-collapse: collapse;"> <tr><td>Connector No.</td><td>B53</td></tr> <tr><td>Connector Name</td><td>REAR DOOR SWITCH RH</td></tr> <tr><td>Connector Type</td><td>A03FW</td></tr> </table>  <table border="1" style="width: 100%; border-collapse: collapse;"> <tr><td>Terminal No.</td><td>2</td></tr> <tr><td>Color of Wire</td><td>LG</td></tr> </table>	Connector No.	B53	Connector Name	REAR DOOR SWITCH RH	Connector Type	A03FW	Terminal No.	2	Color of Wire	LG	<table border="1" style="width: 100%; border-collapse: collapse;"> <tr><td>Terminal No.</td><td>2</td></tr> <tr><td>Color of Wire</td><td>LG</td></tr> </table>	Terminal No.	2	Color of Wire	LG	<table border="1" style="width: 100%; border-collapse: collapse;"> <tr><td>Connector No.</td><td>B71</td></tr> <tr><td>Connector Name</td><td>REAR DOOR SWITCH LH</td></tr> <tr><td>Connector Type</td><td>A03FW</td></tr> </table>  <table border="1" style="width: 100%; border-collapse: collapse;"> <tr><td>Terminal No.</td><td>2</td></tr> <tr><td>Color of Wire</td><td>W</td></tr> </table>	Connector No.	B71	Connector Name	REAR DOOR SWITCH LH	Connector Type	A03FW	Terminal No.	2	Color of Wire	W	<table border="1" style="width: 100%; border-collapse: collapse;"> <tr><td>Terminal No.</td><td>2</td></tr> <tr><td>Color of Wire</td><td>W</td></tr> </table>	Terminal No.	2	Color of Wire	W	<table border="1" style="width: 100%; border-collapse: collapse;"> <tr><td>Connector No.</td><td>E11</td></tr> <tr><td>Connector Name</td><td>IPDM E/R (INTELLIGENT POWER DISTRIBUTION MODULE ENGINE ROOM)</td></tr> <tr><td>Connector Type</td><td>M06FE-LC</td></tr> </table>  <table border="1" style="width: 100%; border-collapse: collapse;"> <tr><td>Terminal No.</td><td>9</td></tr> <tr><td>Color of Wire</td><td>B/W</td></tr> </table>	Connector No.	E11	Connector Name	IPDM E/R (INTELLIGENT POWER DISTRIBUTION MODULE ENGINE ROOM)	Connector Type	M06FE-LC	Terminal No.	9	Color of Wire	B/W	<table border="1" style="width: 100%; border-collapse: collapse;"> <tr><td>Terminal No.</td><td>9</td></tr> <tr><td>Color of Wire</td><td>B/W</td></tr> </table>	Terminal No.	9	Color of Wire	B/W	<table border="1" style="width: 100%; border-collapse: collapse;"> <tr><td>Connector No.</td><td>E12</td></tr> <tr><td>Connector Name</td><td>IPDM E/R (INTELLIGENT POWER DISTRIBUTION MODULE ENGINE ROOM)</td></tr> <tr><td>Connector Type</td><td>NS08FBR-CS</td></tr> </table>  <table border="1" style="width: 100%; border-collapse: collapse;"> <tr><td>Terminal No.</td><td>19</td></tr> <tr><td>Color of Wire</td><td>B/W</td></tr> </table>	Connector No.	E12	Connector Name	IPDM E/R (INTELLIGENT POWER DISTRIBUTION MODULE ENGINE ROOM)	Connector Type	NS08FBR-CS	Terminal No.	19	Color of Wire	B/W	<table border="1" style="width: 100%; border-collapse: collapse;"> <tr><td>Terminal No.</td><td>19</td></tr> <tr><td>Color of Wire</td><td>B/W</td></tr> </table>	Terminal No.	19	Color of Wire	B/W
Connector No.	B4																																																																																																																																														
Connector Name	WIRE TO WIRE																																																																																																																																														
Connector Type	TH24WV-NH																																																																																																																																														
Terminal No.	8																																																																																																																																														
Color of Wire	SB																																																																																																																																														
Terminal No.	20																																																																																																																																														
Color of Wire	LG																																																																																																																																														
Terminal No.	8																																																																																																																																														
Color of Wire	LG																																																																																																																																														
Terminal No.	16																																																																																																																																														
Color of Wire	W																																																																																																																																														
Connector No.	B5																																																																																																																																														
Connector Name	WIRE TO WIRE																																																																																																																																														
Connector Type	TH16MP-NH																																																																																																																																														
Terminal No.	8																																																																																																																																														
Color of Wire	LG																																																																																																																																														
Terminal No.	16																																																																																																																																														
Color of Wire	W																																																																																																																																														
Terminal No.	8																																																																																																																																														
Color of Wire	LG																																																																																																																																														
Terminal No.	16																																																																																																																																														
Color of Wire	W																																																																																																																																														
Connector No.	B27																																																																																																																																														
Connector Name	FRONT DOOR SWITCH (PASSENGER SIDE)																																																																																																																																														
Connector Type	A03FW																																																																																																																																														
Terminal No.	2																																																																																																																																														
Color of Wire	SB																																																																																																																																														
Terminal No.	2																																																																																																																																														
Color of Wire	SB																																																																																																																																														
Connector No.	B34																																																																																																																																														
Connector Name	FRONT DOOR SWITCH (DRIVER SIDE)																																																																																																																																														
Connector Type	A03FW																																																																																																																																														
Terminal No.	2																																																																																																																																														
Color of Wire	LG																																																																																																																																														
Terminal No.	2																																																																																																																																														
Color of Wire	LG																																																																																																																																														
Connector No.	B53																																																																																																																																														
Connector Name	REAR DOOR SWITCH RH																																																																																																																																														
Connector Type	A03FW																																																																																																																																														
Terminal No.	2																																																																																																																																														
Color of Wire	LG																																																																																																																																														
Terminal No.	2																																																																																																																																														
Color of Wire	LG																																																																																																																																														
Connector No.	B71																																																																																																																																														
Connector Name	REAR DOOR SWITCH LH																																																																																																																																														
Connector Type	A03FW																																																																																																																																														
Terminal No.	2																																																																																																																																														
Color of Wire	W																																																																																																																																														
Terminal No.	2																																																																																																																																														
Color of Wire	W																																																																																																																																														
Connector No.	E11																																																																																																																																														
Connector Name	IPDM E/R (INTELLIGENT POWER DISTRIBUTION MODULE ENGINE ROOM)																																																																																																																																														
Connector Type	M06FE-LC																																																																																																																																														
Terminal No.	9																																																																																																																																														
Color of Wire	B/W																																																																																																																																														
Terminal No.	9																																																																																																																																														
Color of Wire	B/W																																																																																																																																														
Connector No.	E12																																																																																																																																														
Connector Name	IPDM E/R (INTELLIGENT POWER DISTRIBUTION MODULE ENGINE ROOM)																																																																																																																																														
Connector Type	NS08FBR-CS																																																																																																																																														
Terminal No.	19																																																																																																																																														
Color of Wire	B/W																																																																																																																																														
Terminal No.	19																																																																																																																																														
Color of Wire	B/W																																																																																																																																														

A
B
C
D
E
F
G
H
I
J
K
EXL
M
N
O
P

JCLWM3497GB

AUTO LIGHT SYSTEM

< DTC/CIRCUIT DIAGNOSIS >

AUTO LIGHT SYSTEM

Connector No.	E105
Connector Name	WIRE TO WIRE
Connector Type	TH80MM-CS16-TM4

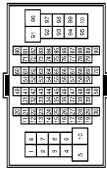

Terminal No.	Color of Wire	Signal Name [Specification]
80	P	-
81	L	-
96	LG	-

Connector No.	E15
Connector Name	IPDM E/R (INTELLIGENT POWER DISTRIBUTION MODULE ENGINE ROOM)
Connector Type	NS16FW-CS

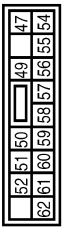

Terminal No.	Color of Wire	Signal Name [Specification]
49	W	-
50	GR	-
51	R	-
52	P	-

Connector No.	E14
Connector Name	IPDM E/R (INTELLIGENT POWER DISTRIBUTION MODULE ENGINE ROOM)
Connector Type	NS17FER-CS

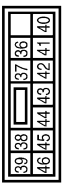

Terminal No.	Color of Wire	Signal Name [Specification]
36	O	-
37	V	-
38	G	-
41	SB	-

Connector No.	E13
Connector Name	IPDM E/R (INTELLIGENT POWER DISTRIBUTION MODULE ENGINE ROOM)
Connector Type	TH12FW-NH

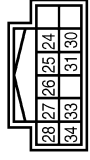

Terminal No.	Color of Wire	Signal Name [Specification]
26	P	-
27	L	-

Connector No.	M27
Connector Name	COMBINATION SWITCH
Connector Type	TH16FW-NH

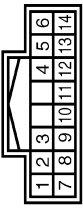

Terminal No.	Color of Wire	Signal Name [Specification]
2	GR	INPUT 4
5	L/Y	INPUT 3
7	W	OUTPUT 3
8	BR/W	INPUT 5
9	R/L	OUTPUT 2
10	Y/L	OUTPUT 4
11	L/O	OUTPUT 1
12	L/R	INPUT 1
13	LG	OUTPUT 5
14	G	INPUT 2

Connector No.	M17
Connector Name	OPTICAL SENSOR
Connector Type	TK03FW



Terminal No.	Color of Wire	Signal Name [Specification]
1	R/G	POWER
2	L/B	OUTPUT
3	V	GND

Connector No.	M4
Connector Name	DATA LINK CONNECTOR
Connector Type	BD16FW

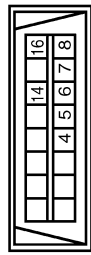

Terminal No.	Color of Wire	Signal Name [Specification]
6	L	-
14	P	-

JCLWM3498GB

AUTO LIGHT SYSTEM

< DTC/CIRCUIT DIAGNOSIS >

AUTO LIGHT SYSTEM

Connector No.	M65
Connector Name	BCM (BODY CONTROL MODULE) (WITHOUT INTELLIGENT KEY)
Connector Type	TH40FB-NH

Terminal No.	2	3	4	5	6	11	12	13	14	17	18
Color of Wire	BR/W	GR	L/Y	G	L/R	L/Y	SB	GR/L	L/B	R/G	V
Signal Name [Specification]	COMBI SW INPUT 5	COMBI SW INPUT 4	COMBI SW INPUT 3	COMBI SW INPUT 2	COMBI SW INPUT 1	ACC	PASSENGER DOOR SW	REAR RH DOOR SW	OPTICAL SENSOR	OPTICAL SENSOR POWER SUPPLY	RECEIVER/SENSOR GND

Terminal No.	2	3	4	5	6	11	12	13	14	17	18
Color of Wire	BR/W	GR	L/Y	G	L/R	L/Y	SB	GR/L	L/B	R/G	V
Signal Name [Specification]	COMBI SW INPUT 5	COMBI SW INPUT 4	COMBI SW INPUT 3	COMBI SW INPUT 2	COMBI SW INPUT 1	ACC	PASSENGER DOOR SW	REAR RH DOOR SW	OPTICAL SENSOR	OPTICAL SENSOR POWER SUPPLY	RECEIVER/SENSOR GND

Connector No.	M68
Connector Name	BCM (BODY CONTROL MODULE) (WITH INTELLIGENT KEY)
Connector Type	TH40FB-NH

Terminal No.	2	3	4	5	6	11	12	13	14	15	17	18	19	20
Color of Wire	BR/W	GR	L/Y	G	L/R	L/Y	SB	GR/L	L/B	R/G	V	Y	B	Y
Signal Name [Specification]	COMBI SW INPUT 5	COMBI SW INPUT 4	COMBI SW INPUT 3	COMBI SW INPUT 2	COMBI SW INPUT 1	ACC F/B	PASSENGER DOOR SW	REAR RH DOOR SW	OPTICAL SENSOR	OPTICAL SENSOR POWER SUPPLY	RECEIVER/SENSOR GND	BAT (FUSE)	GND	BAT (F/L)

Terminal No.	2	3	4	5	6	11	12	13	14	17	18
Color of Wire	BR/W	GR	L/Y	G	L/R	L/Y	SB	GR/L	L/B	R/G	V
Signal Name [Specification]	COMBI SW INPUT 5	COMBI SW INPUT 4	COMBI SW INPUT 3	COMBI SW INPUT 2	COMBI SW INPUT 1	ACC F/B	PASSENGER DOOR SW	REAR RH DOOR SW	OPTICAL SENSOR	OPTICAL SENSOR POWER SUPPLY	RECEIVER/SENSOR GND

32	LG	COMBI SW OUTPUT 5
33	Y/L	COMBI SW OUTPUT 4
34	W	COMBI SW OUTPUT 3
35	R/L	COMBI SW OUTPUT 2
36	L/O	COMBI SW OUTPUT 1
38	O	IGN
39	L	CAN-H
40	P	CAN-L

32	LG	COMBI SW OUTPUT 5
33	Y/L	COMBI SW OUTPUT 4
34	W	COMBI SW OUTPUT 3
35	R/L	COMBI SW OUTPUT 2
36	L/O	COMBI SW OUTPUT 1
38	O	IGN F/B
39	L	CAN-H
40	P	CAN-L

Connector No.	M66
Connector Name	BCM (BODY CONTROL MODULE) (WITHOUT INTELLIGENT KEY)
Connector Type	FEA09FW-FHA0-SA

Terminal No.	43	44	45	46	47	48	49
Color of Wire	BR/Y	W/G					
Signal Name [Specification]	DRIVER DOOR SW	REAR LH DOOR SW					

Terminal No.	47	48
Color of Wire	BR/Y	W/G
Signal Name [Specification]	DRIVER DOOR SW	REAR LH DOOR SW

Connector No.	M69
Connector Name	BCM (BODY CONTROL MODULE) (WITH INTELLIGENT KEY)
Connector Type	FEA09FW-FHA0-SA

Terminal No.	43	44	45	46	47	48	49
Color of Wire	BR/Y	W/G					
Signal Name [Specification]	DRIVER DOOR SW	REAR LH DOOR SW					

Terminal No.	47	48
Color of Wire	BR/Y	W/G
Signal Name [Specification]	DRIVER DOOR SW	REAR LH DOOR SW

Connector No.	M67
Connector Name	BCM (BODY CONTROL MODULE) (WITHOUT INTELLIGENT KEY)
Connector Type	FEA09FB-FHA0-SA

Terminal No.	56	57	59	60	61	63
Color of Wire	Y	Y				
Signal Name [Specification]	BAT (FUSE)	GND	BAT (F/L)			

Terminal No.	57	67	70
Color of Wire	Y	B	Y
Signal Name [Specification]	BAT (FUSE)	GND	BAT (F/L)

Connector No.	M70
Connector Name	BCM (BODY CONTROL MODULE) (WITH INTELLIGENT KEY)
Connector Type	FEA09FB-FHA0-SA

Terminal No.	56	57	59	60	61	63
Color of Wire	Y	Y				
Signal Name [Specification]	BAT (FUSE)	GND	BAT (F/L)			

Terminal No.	57	67	70
Color of Wire	Y	B	Y
Signal Name [Specification]	BAT (FUSE)	GND	BAT (F/L)

A B C D E F G H I J K EXL M N O P

AUTO LIGHT SYSTEM

< DTC/CIRCUIT DIAGNOSIS >

AUTO LIGHT SYSTEM

Connector No.	M77
Connector Name	WIRE TO WIRE
Connector Type	TH807W-C516-TM4

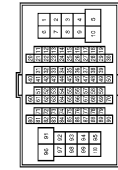

Terminal No.	Color of Wire	Signal Name [Specification]
80	P	-
81	L	-
96	Y	-

Connector No.	M79
Connector Name	WIRE TO WIRE
Connector Type	TH24FW-NH

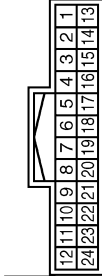

Terminal No.	Color of Wire	Signal Name [Specification]
8	SB	-
20	GR/L	-

Connector No.	M80
Connector Name	WIRE TO WIRE
Connector Type	TH16FW-NH

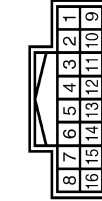

Terminal No.	Color of Wire	Signal Name [Specification]
8	BR/Y	-
16	W/G	-

JCLWM3500GB

DAYTIME RUNNING LIGHT SYSTEM

< DTC/CIRCUIT DIAGNOSIS >

DAYTIME RUNNING LIGHT SYSTEM

Wiring Diagram - DAYTIME RUNNING LIGHT SYSTEM -

INFOID:000000004992004

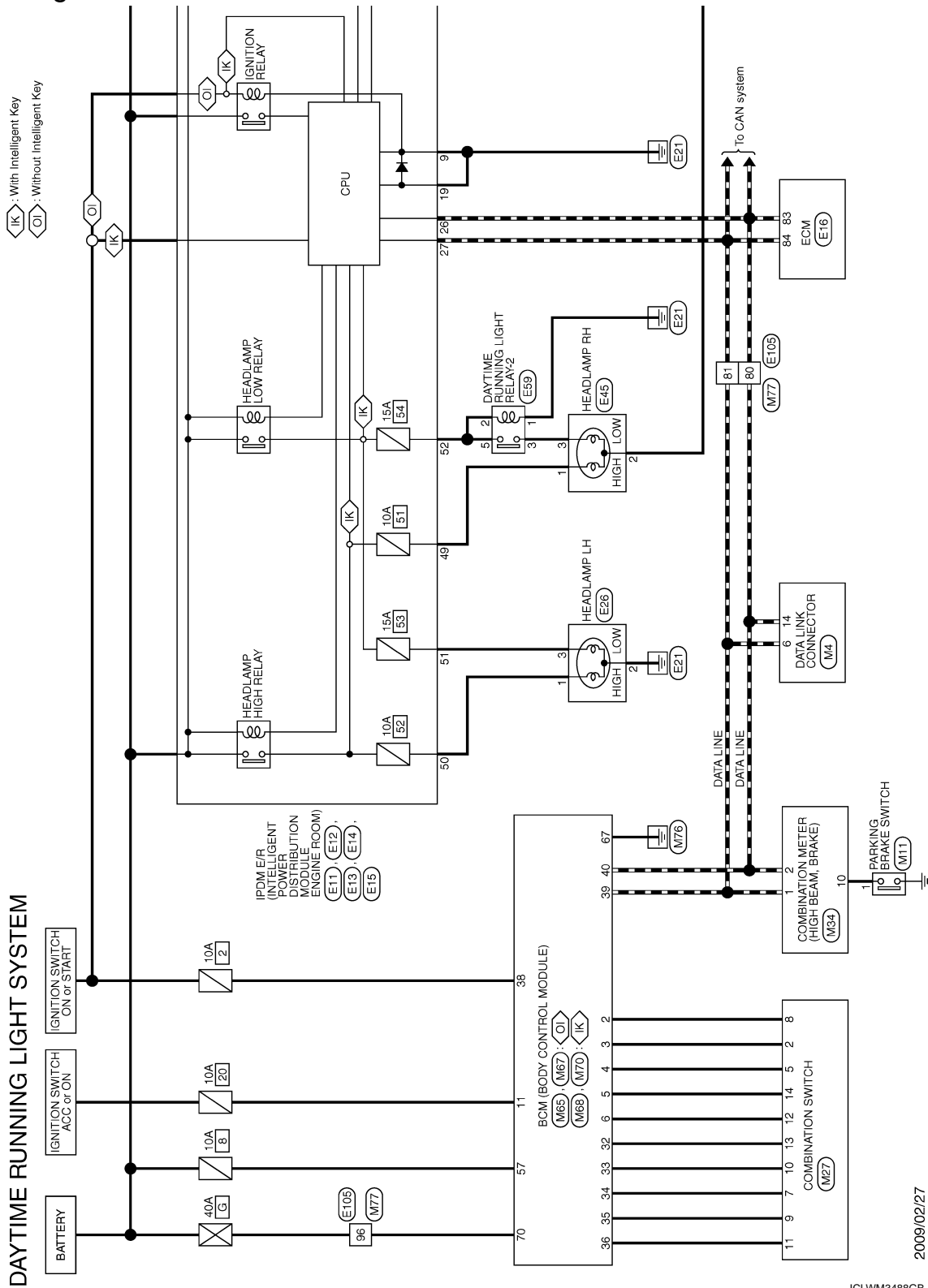

A
B
C
D
E
F
G
H
I
J
K
L
M
N
O
P

EXL

DAYTIME RUNNING LIGHT SYSTEM

< DTC/CIRCUIT DIAGNOSIS >

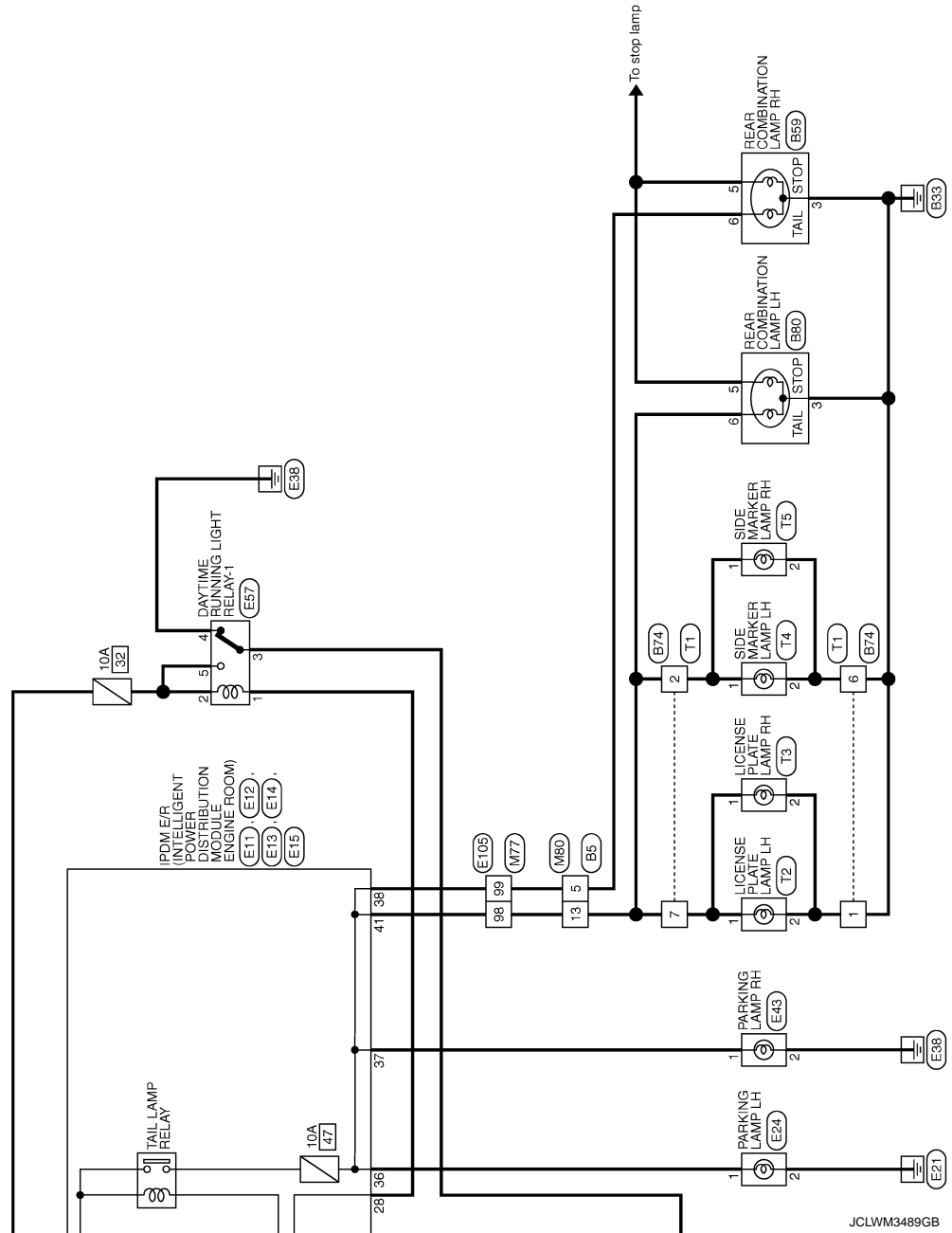

DAYTIME RUNNING LIGHT SYSTEM

< DTC/CIRCUIT DIAGNOSIS >

DAYTIME RUNNING LIGHT SYSTEM

Connector No.	B5
Connector Name	WIRE TO WIRE
Connector Type	TH16MW-NH



Terminal No.	Color of Wire	Signal Name [Specification]
5	V	-
13	GR	-

Connector No.	B59
Connector Name	REAR COMBINATION LAMP RH
Connector Type	RS00FB-PR



Terminal No.	Color of Wire	Signal Name [Specification]
3	B	-
5	R	-
6	V	-

Connector No.	B74
Connector Name	WIRE TO WIRE
Connector Type	RH10FB



Terminal No.	Color of Wire	Signal Name [Specification]
1	B	-
2	GR	-
6	B	-
7	GR	-

Connector No.	B80
Connector Name	REAR COMBINATION LAMP LH
Connector Type	RS00FB-PR



Terminal No.	Color of Wire	Signal Name [Specification]
3	B	-
5	R	-
6	GR	-

Connector No.	E11
Connector Name	IPDM E/R (INTELLIGENT POWER DISTRIBUTION MODULE ENGINE ROOM)
Connector Type	M08FB-LC



Terminal No.	Color of Wire	Signal Name [Specification]
9	B/W	-

Connector No.	E12
Connector Name	IPDM E/R (INTELLIGENT POWER DISTRIBUTION MODULE ENGINE ROOM)
Connector Type	NS00FBR-CS



Terminal No.	Color of Wire	Signal Name [Specification]
19	B/W	-

Connector No.	E13
Connector Name	IPDM E/R (INTELLIGENT POWER DISTRIBUTION MODULE ENGINE ROOM)
Connector Type	TH12FW-NH



Terminal No.	Color of Wire	Signal Name [Specification]
28	P	-
27	L	-
28	P	-

Connector No.	E14
Connector Name	IPDM E/R (INTELLIGENT POWER DISTRIBUTION MODULE ENGINE ROOM)
Connector Type	NS12FBR-CS

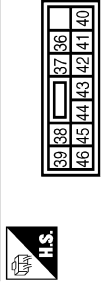

Terminal No.	Color of Wire	Signal Name [Specification]
36	O	-
37	V	-
38	G	-
41	SB	-

JCLWM3490GB

A
B
C
D
E
F
G
H
I
J
K
L
M
N
O
P

EXL

DAYTIME RUNNING LIGHT SYSTEM

< DTC/CIRCUIT DIAGNOSIS >

DAYTIME RUNNING LIGHT SYSTEM

Connector No.	E13
Connector Name	IPDM E/R (INTELLIGENT POWER DISTRIBUTION MODULE ENGINE ROOM)
Connector Type	MS16FY-CS

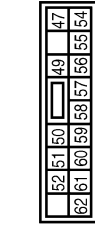

Terminal No.	Color of Wire	Signal Name [Specification]
49	W	-
50	GR	-
51	R	-
52	P	-

Connector No.	E16
Connector Name	ECM
Connector Type	RK2ZFB-RZB-L-RH

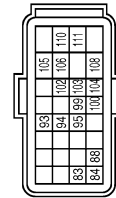

Terminal No.	Color of Wire	Signal Name [Specification]
83	L	CAN-L
84	P	CAN-H

Connector No.	E24
Connector Name	PARKING LAMP LH
Connector Type	RK02FB



Terminal No.	Color of Wire	Signal Name [Specification]
1	Y	-
2	B/R	-

Connector No.	E26
Connector Name	HEADLAMP LH
Connector Type	NG03FB



Terminal No.	Color of Wire	Signal Name [Specification]
1	GR	-
2	B/R	-
3	R	-

Connector No.	E43
Connector Name	PARKING LAMP RH
Connector Type	RK02FB



Terminal No.	Color of Wire	Signal Name [Specification]
1	V	-
2	B/Y	-

Connector No.	E45
Connector Name	HEADLAMP RH
Connector Type	NG03FB



Terminal No.	Color of Wire	Signal Name [Specification]
1	W	-
2	R	-[With daytime running light system]
3	SB	-[With daytime running light system]

Connector No.	E57
Connector Name	DAYTIME RUNNING LIGHT RELAY-1
Connector Type	MS03FB-MZ-LC



Terminal No.	Color of Wire	Signal Name [Specification]
1	P	-
2	LG	-
3	R	-
4	B/Y	-
5	LG	-

Connector No.	E59
Connector Name	DAYTIME RUNNING LIGHT RELAY-2
Connector Type	MS02FL-M2-LC



Terminal No.	Color of Wire	Signal Name [Specification]
1	B/Y	-
2	P	-
3	SB	-
5	P	-

DAYTIME RUNNING LIGHT SYSTEM

< DTC/CIRCUIT DIAGNOSIS >

DAYTIME RUNNING LIGHT SYSTEM

Connector No.	E105
Connector Name	WIRE TO WIRE
Connector Type	TH80WV-CS (F-TM4)

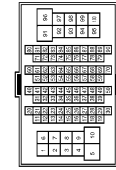

Terminal No.	Color of Wire	Signal Name [Specification]
80	P	-
81	L	-
96	LG	-
98	SB	-
99	G	-

Connector No.	M4
Connector Name	DATA LINK CONNECTOR
Connector Type	BD16FW

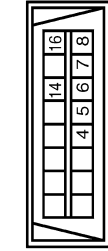

Terminal No.	Color of Wire	Signal Name [Specification]
6	L	-
14	P	-

Connector No.	M11
Connector Name	PARKING BRAKE SWITCH
Connector Type	F01FB-A



Terminal No.	Color of Wire	Signal Name [Specification]
1	SB	-

Connector No.	M27
Connector Name	COMBINATION SWITCH
Connector Type	TH18FW-NH

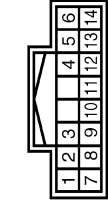

Terminal No.	Color of Wire	Signal Name [Specification]
2	GR	INPUT 4
5	L/Y	INPUT 3
7	W	OUTPUT 3
8	BR/W	INPUT 5
9	B/L	OUTPUT 2
10	Y/L	OUTPUT 4
11	L/O	OUTPUT 1
12	L/R	INPUT 1
13	LG	OUTPUT 5
14	G	INPUT 2

Connector No.	M34
Connector Name	COMBINATION METER
Connector Type	TH40FW-NH

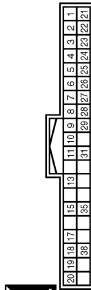

Terminal No.	Color of Wire	Signal Name [Specification]
1	L	CAN-H
2	P	CAN-L
10	SB	PARKING BRAKE SWITCH SIGNAL

Connector No.	M85
Connector Name	BCM (BODY CONTROL MODULE) (WITHOUT INTELLIGENT KEY)
Connector Type	TH40FW-NH

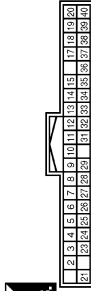

Terminal No.	Color of Wire	Signal Name [Specification]
2	BR/W	COMBI SW INPUT 5
3	GR	COMBI SW INPUT 4
4	L/Y	COMBI SW INPUT 3
5	G	COMBI SW INPUT 2
6	L/R	COMBI SW INPUT 1
11	L/Y	ACC
32	LG	COMBI SW OUTPUT 5
33	Y/L	COMBI SW OUTPUT 4
34	W	COMBI SW OUTPUT 3
35	R/L	COMBI SW OUTPUT 2
36	L/O	COMBI SW OUTPUT 1

Connector No.	M67
Connector Name	BCM (BODY CONTROL MODULE) (WITHOUT INTELLIGENT KEY)
Connector Type	FEA09FB-FHA6-SA



Terminal No.	Color of Wire	Signal Name [Specification]
57	Y	BAT (FUSE)
67	B	GND
70	Y	BAT (F.L)

JCLWM3492GB

A
B
C
D
E
F
G
H
I
J
K
EXL
M
N
O
P

DAYTIME RUNNING LIGHT SYSTEM

< DTC/CIRCUIT DIAGNOSIS >

DAYTIME RUNNING LIGHT SYSTEM

Connector No.	M68
Connector Name	BCM BODY CONTROL MODULE (WITH INTELLIGENT KEY)
Connector Type	TH40FB-NH

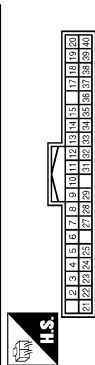

Terminal No.	Color of Wire	Signal Name [Specification]
2	BR/W	COMBI SW INPUT 5
3	GR	COMBI SW INPUT 4
4	L/Y	COMBI SW INPUT 3
5	G	COMBI SW INPUT 2
6	L/R	COMBI SW INPUT 1
11	L/Y	ACC F/B
32	LG	COMBI SW OUTPUT 5
33	Y/L	COMBI SW OUTPUT 4
34	W	COMBI SW OUTPUT 3
35	R/L	COMBI SW OUTPUT 2
36	L/O	COMBI SW OUTPUT 1

Connector No.	M80
Connector Name	WIRE TO WIRE
Connector Type	TH16FV-NH

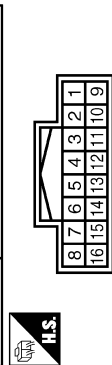

Terminal No.	Color of Wire	Signal Name [Specification]
5	W	
13	BR/W	

38	O	IGN F/B
39	L	CAN-H
40	P	CAN-L



Terminal No.	Color of Wire	Signal Name [Specification]
57	Y	BAT (FUSE)
67	B	GND
70	Y	BAT (F/L)

Connector No.	T2
Connector Name	LICENSE PLATE LAMP LH
Connector Type	RK02FBR

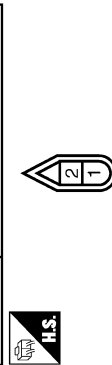

Terminal No.	Color of Wire	Signal Name [Specification]
1	W	
2	BR	

Connector No.	M77
Connector Name	WIRE TO WIRE
Connector Type	TH80FW-CS1P-TM4

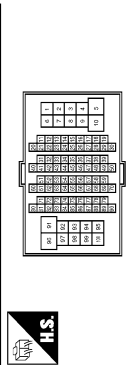

Terminal No.	Color of Wire	Signal Name [Specification]
80	P	
81	L	
86	Y	
88	BR/W	
89	W	

Connector No.	T3
Connector Name	LICENSE PLATE LAMP RH
Connector Type	RK02FBR

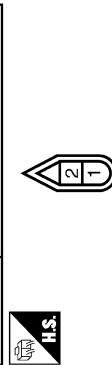

Terminal No.	Color of Wire	Signal Name [Specification]
1	GR	
2	B	

JCLWM3493GB

DAYTIME RUNNING LIGHT SYSTEM

< DTC/CIRCUIT DIAGNOSIS >

DAYTIME RUNNING LIGHT SYSTEM

Connector No.	T14
Connector Name	SIDE MARKER LAMP LH
Connector Type	HS02FG-W



Terminal No.	Color of Wire	Signal Name [Specification]
1	GR	-
2	B	-

Connector No.	T15
Connector Name	SIDE MARKER LAMP RH
Connector Type	HS02FG-W



Terminal No.	Color of Wire	Signal Name [Specification]
1	GR	-
2	B	-

A
B
C
D
E
F
G
H
I
J
K
EXL
M
N
O
P

JCLWM3494GB

FRONT FOG LAMP SYSTEM

< DTC/CIRCUIT DIAGNOSIS >

FRONT FOG LAMP SYSTEM

Wiring Diagram - FRONT FOG LAMP -

INFOID:000000004992005

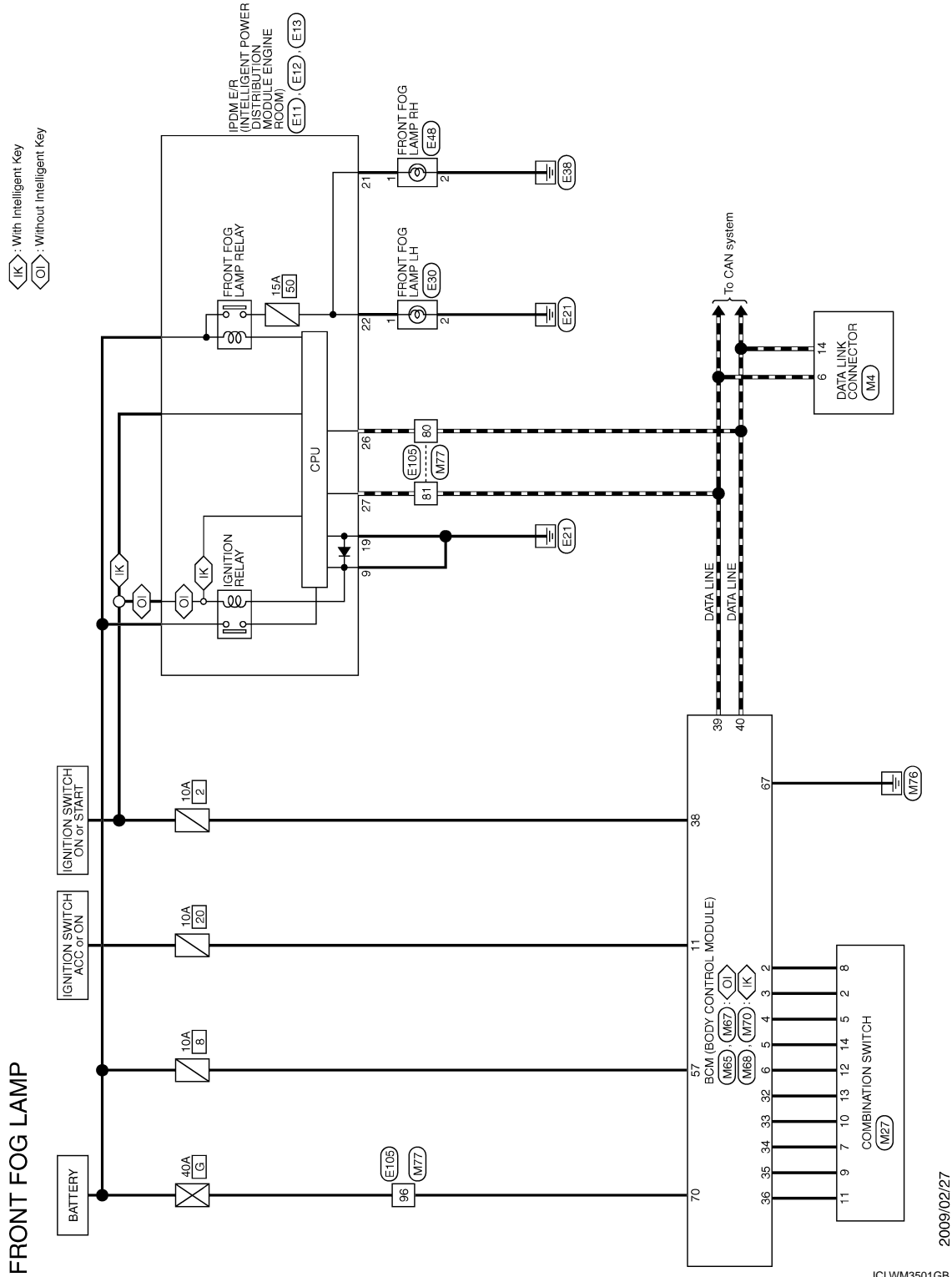





2009/02/27

JCLWM3501GB

FRONT FOG LAMP SYSTEM

< DTC/CIRCUIT DIAGNOSIS >

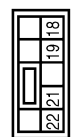
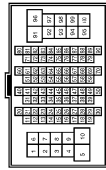
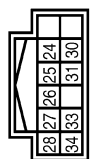
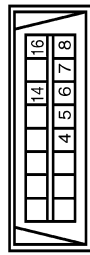
FRONT FOG LAMP

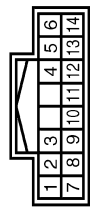
Connector No. E11	IPDM E/R (INTELLIGENT POWER DISTRIBUTION MODULE ENGINE ROOM)	MOBEP-LC		Terminal No. 9	Color of Wire B/W	Signal Name [Specification]	Connector No. E48	FRONT FOG LAMP RH	FCI 240P-C023S4019		Terminal No. 1 2	Color of Wire W B/Y	Signal Name [Specification]
Connector No. E12	IPDM E/R (INTELLIGENT POWER DISTRIBUTION MODULE ENGINE ROOM)	NSGFBR-CS		Terminal No. 19 21 22	Color of Wire B/W W V	Signal Name [Specification]	Connector No. E05	WIRE TO WIRE	TH80MW-CS16-TM4		Terminal No. 80 81 96	Color of Wire P L LG	Signal Name [Specification]
Connector No. E13	IPDM E/R (INTELLIGENT POWER DISTRIBUTION MODULE ENGINE ROOM)	TH12FW-NH		Terminal No. 28 27	Color of Wire P L	Signal Name [Specification]	Connector No. M4	DATA LINK CONNECTOR	BD16FW		Terminal No. 6 14	Color of Wire L P	Signal Name [Specification]
Connector No. E40	FRONT FOG LAMP LH	FCI 240P-C023S4019		Terminal No. 1 2	Color of Wire V B/W	Signal Name [Specification]	Connector No. M27	COMBINATION SWITCH	TH18FW-NH		Terminal No. 2 5 7 8 9 10 11 12 13 14	Color of Wire GR L/Y W BR/W R/L Y/L L/O L/R LG G	Signal Name [Specification]

JCLWM3502GB

A
B
C
D
E
F
G
H
I
J
K
EXL
M
N
O
P

FRONT FOG LAMP SYSTEM

< DTC/CIRCUIT DIAGNOSIS >

FRONT FOG LAMP

Connector No.	M65
Connector Name	BCM (BODY CONTROL MODULE) (WITHOUT INTELLIGENT KEY)
Connector Type	TH407V-NH



2	3	4	5	6	7	8	9	10	11	12	13	14	15	17	18	19	20
21	22	23	24	25	27	28	29	31	32	33	34	35	36	37	38	39	40

Terminal No.	Color of Wire	Signal Name [Specification]
2	BR/W	COMBI SW INPUT 5
3	GR	COMBI SW INPUT 4
4	L/Y	COMBI SW INPUT 3
5	G	COMBI SW INPUT 2
6	L/R	COMBI SW INPUT 1
11	L/Y	ACC
32	LG	COMBI SW OUTPUT 5
33	Y/L	COMBI SW OUTPUT 4
34	W	COMBI SW OUTPUT 3
35	R/L	COMBI SW OUTPUT 2
36	L/O	COMBI SW OUTPUT 1

Connector No.	M68
Connector Name	BCM (BODY CONTROL MODULE) (WITH INTELLIGENT KEY)
Connector Type	TH407B-NH



2	3	4	5	6	7	8	9	10	11	12	13	14	15	17	18	19	20
21	22	23	24	25	27	28	29	31	32	33	34	35	36	37	38	39	40

Terminal No.	Color of Wire	Signal Name [Specification]
2	BR/W	COMBI SW INPUT 5
3	GR	COMBI SW INPUT 4
4	L/Y	COMBI SW INPUT 3
5	G	COMBI SW INPUT 2
6	L/R	COMBI SW INPUT 1
11	L/Y	ACC F/B
32	LG	COMBI SW OUTPUT 5
33	Y/L	COMBI SW OUTPUT 4
34	W	COMBI SW OUTPUT 3
35	R/L	COMBI SW OUTPUT 2
36	L/O	COMBI SW OUTPUT 1

38	O	IGN
39	L	CAN-H
40	P	CAN-L

Connector No.	M67
Connector Name	BCM (BODY CONTROL MODULE) (WITHOUT INTELLIGENT KEY)
Connector Type	FEA09FB-FHA6-SA



56	57	59	60	61	63
65	66	67	68	69	70

Terminal No.	Color of Wire	Signal Name [Specification]
57	Y	BAT (FUSE)
67	B	GND
70	Y	BAT (F/L)

38	O	IGN F/B
39	L	CAN-H
40	P	CAN-L

Connector No.	M70
Connector Name	BCM (BODY CONTROL MODULE) (WITH INTELLIGENT KEY)
Connector Type	FEA09FB-FHA6-SA



56	57	59	60	61	63
65	66	67	68	69	70

Terminal No.	Color of Wire	Signal Name [Specification]
57	Y	BAT (FUSE)
67	B	GND
70	Y	BAT (F/L)

Connector No.	M77
Connector Name	WIRE TO WIRE
Connector Type	TH80FW-CST6-TM4



1	2	3	4	5	6	7	8	9	10	11	12	13	14	15	16	17	18	19	20	21	22	23	24	25	26	27	28	29	30	31	32	33	34	35	36	37	38	39	40	41	42	43	44	45	46	47	48	49	50	51	52	53	54	55	56	57	58	59	60	61	62	63	64	65	66	67	68	69	70	71	72	73	74	75	76	77	78	79	80	81	82	83	84	85	86	87	88	89	90	91	92	93	94	95	96	97	98	99	100
---	---	---	---	---	---	---	---	---	----	----	----	----	----	----	----	----	----	----	----	----	----	----	----	----	----	----	----	----	----	----	----	----	----	----	----	----	----	----	----	----	----	----	----	----	----	----	----	----	----	----	----	----	----	----	----	----	----	----	----	----	----	----	----	----	----	----	----	----	----	----	----	----	----	----	----	----	----	----	----	----	----	----	----	----	----	----	----	----	----	----	----	----	----	----	----	----	----	----	-----

Terminal No.	Color of Wire	Signal Name [Specification]
80	P	—
81	L	—
96	Y	—

TURN SIGNAL AND HAZARD WARNING LAMP SYSTEM

< DTC/CIRCUIT DIAGNOSIS >

TURN SIGNAL AND HAZARD WARNING LAMP SYSTEM

Wiring Diagram - TURN AND HAZARD WARNING LAMPS -

INFOID:000000004992006

TURN SIGNAL AND HAZARD WARNING LAMPS

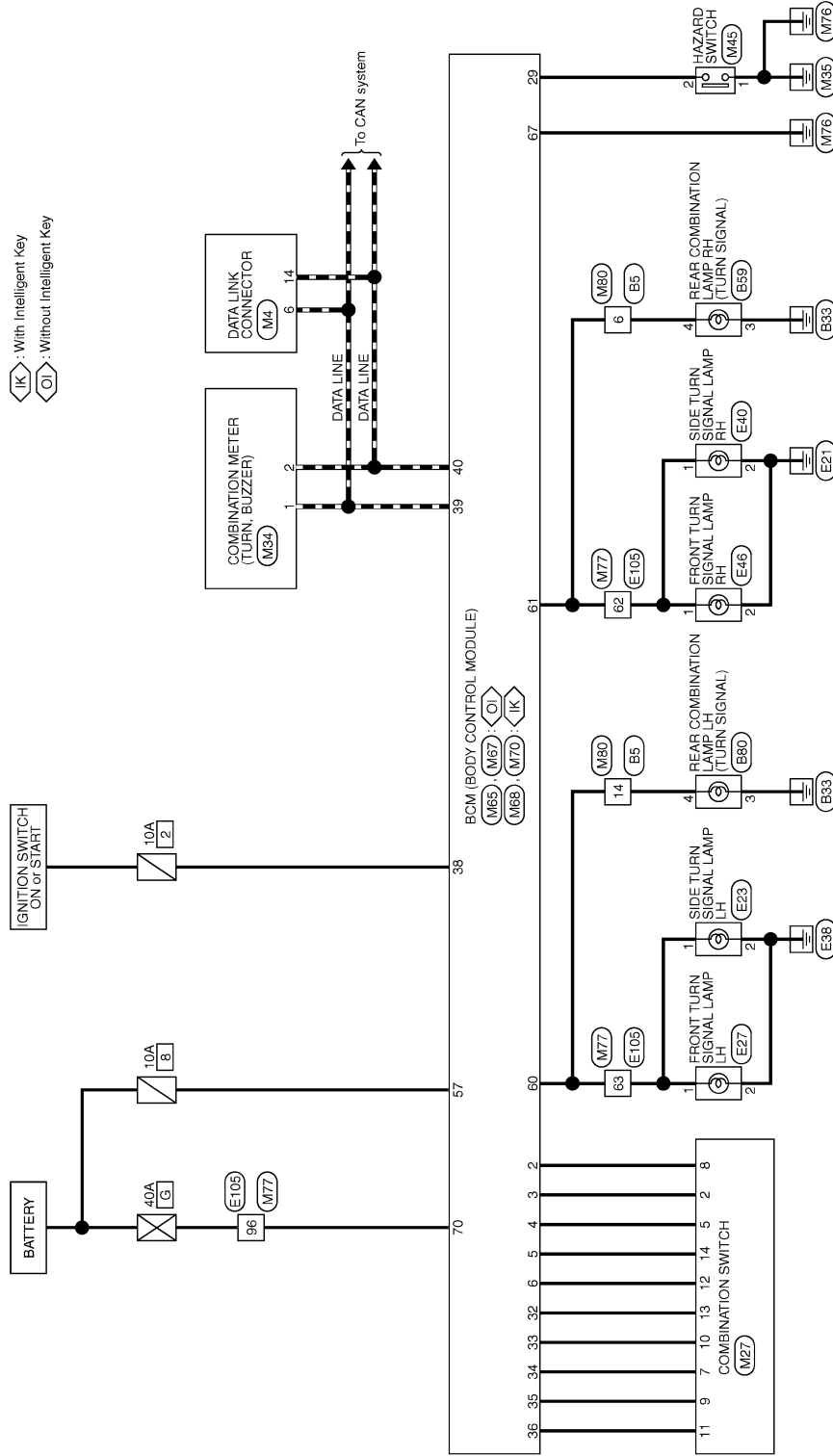

: With Intelligent Key
 : Without Intelligent Key

A
B
C
D
E
F
G
H
I
J
K
L
M
N
O
P

EXL

2009/02/27

JCLWM3504GB

TURN SIGNAL AND HAZARD WARNING LAMP SYSTEM

< DTC/CIRCUIT DIAGNOSIS >

TURN SIGNAL AND HAZARD WARNING LAMPS

Connector No. B5	WIRE TO WIRE TH16MW-NH		Terminal No. 6 14	Color of Wire W P	Signal Name [Specification] - -	Connector No. E23	SIDE TURN SIGNAL LAMP LH STL02FW		Terminal No. 1 2	Color of Wire L B/R	Signal Name [Specification] - -
Connector No. B59	REAR COMBINATION LAMP RH RS02FB-PR		Terminal No. 3 4	Color of Wire B W	Signal Name [Specification] - -	Connector No. E46	FRONT TURN SIGNAL LAMP RH RS02FB		Terminal No. 3 4	Color of Wire B P	Signal Name [Specification] - -
Connector No. B80	REAR COMBINATION LAMP LH RS02FB-PR		Terminal No. 3 4	Color of Wire B P	Signal Name [Specification] - -	Connector No. E40	SIDE TURN SIGNAL LAMP RH STL02FW		Terminal No. 1 2	Color of Wire W B/Y	Signal Name [Specification] - -
Connector No. E27	FRONT TURN SIGNAL LAMP LH RS02FB		Terminal No. 1 2	Color of Wire L B/W	Signal Name [Specification] - -	Connector No. E05	WIRE TO WIRE TH80MW-C516-TM4		Terminal No. 62 63 96	Color of Wire W L LG	Signal Name [Specification] - -

JCLWM3505GB

TURN SIGNAL AND HAZARD WARNING LAMP SYSTEM

< DTC/CIRCUIT DIAGNOSIS >

TURN SIGNAL AND HAZARD WARNING LAMPS

Connector No.	M45
Connector Name	HAZARD SWITCH
Connector Type	TC04FW



Terminal No.	Color of Wire	Signal Name [Specification]
1	B	
2	L/W	

Connector No.	M34
Connector Name	COMBINATION METER
Connector Type	TH04FW-NH



Terminal No.	Color of Wire	Signal Name [Specification]
1	L	CAN-H
2	P	CAN-L

Connector No.	M67
Connector Name	BCM (BODY CONTROL MODULE) (WITHOUT INTELLIGENT KEY)
Connector Type	FEA09FB-FHAG-SA



Terminal No.	Color of Wire	Signal Name [Specification]
57	Y	BAT (FUSE)
60	W/B	TURN SIGNAL LH OUTPUT
61	W/L	TURN SIGNAL RH OUTPUT
67	B	GND
70	Y	BAT (F/L)

Connector No.	M27
Connector Name	COMBINATION SWITCH
Connector Type	TH15FW-NH



Terminal No.	Color of Wire	Signal Name [Specification]
2	GR	INPUT 4
5	L/Y	INPUT 3
7	W	OUTPUT 3
8	BR/W	INPUT 5
9	BR/W	OUTPUT 2
10	Y/L	OUTPUT 4
11	L/O	OUTPUT 1
12	L/R	INPUT 1
13	LG	OUTPUT 5
14	G	INPUT 2

38	O	IGN
39	L	CAN-H
40	P	CAN-L

Connector No.	M4
Connector Name	DATA LINK CONNECTOR
Connector Type	BD15FW

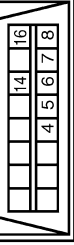

Terminal No.	Color of Wire	Signal Name [Specification]
6	L	
14	P	

Connector No.	M65
Connector Name	BCM (BODY CONTROL MODULE) (WITHOUT INTELLIGENT KEY)
Connector Type	TH04FW-NH



Terminal No.	Color of Wire	Signal Name [Specification]
2	BR/W	COMBI SW INPUT 5
3	GR	COMBI SW INPUT 4
4	L/Y	COMBI SW INPUT 3
5	G	COMBI SW INPUT 2
6	L/R	COMBI SW INPUT 1
29	L/W	HAZARD SW
32	LG	COMBI SW OUTPUT 5
33	Y/L	COMBI SW OUTPUT 4
34	W	COMBI SW OUTPUT 3
35	R/L	COMBI SW OUTPUT 2
36	L/O	COMBI SW OUTPUT 1

JCLWM3506GB

A
B
C
D
E
F
G
H
I
J
K
EXL
M
N
O
P

TURN SIGNAL AND HAZARD WARNING LAMP SYSTEM

< DTC/CIRCUIT DIAGNOSIS >

TURN SIGNAL AND HAZARD WARNING LAMPS

Connector No.	M68	IGN F/B
Connector Name	BCM BODY CONTROL MODULE (WITH INTELLIGENT KEY)	CAN-H
Connector Type	TH40FB-NH	CAN-L

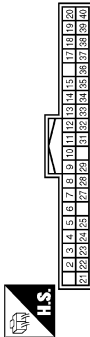

Terminal No.	Color of Wire	Signal Name [Specification]
2	BR/W	COMBI SW INPUT 5
3	GR	COMBI SW INPUT 4
4	L/Y	COMBI SW INPUT 3
5	G	COMBI SW INPUT 2
6	L/R	COMBI SW INPUT 1
28	L/W	HAZARD SW
32	LG	COMBI SW OUTPUT 5
33	Y/L	COMBI SW OUTPUT 4
34	W	COMBI SW OUTPUT 3
35	R/L	COMBI SW OUTPUT 2
36	L/O	COMBI SW OUTPUT 1

Connector No.	M80	WIRE TO WIRE
Connector Name	TH16FV-NH	



Terminal No.	Color of Wire	Signal Name [Specification]
6	W/L	
14	W/B	

38	O	IGN F/B
39	L	CAN-H
40	P	CAN-L

Connector No.	M70	BCM BODY CONTROL MODULE (WITH INTELLIGENT KEY)
Connector Name	FE209FB-FH4G-SA	
Connector Type		



Terminal No.	Color of Wire	Signal Name [Specification]
57	Y	BAT (FUSE)
60	W/B	TURN SIGNAL LH OUTPUT
61	W/L	TURN SIGNAL RH OUTPUT
67	B	GND
70	Y	BAT (F/L)

Connector No.	M77	WIRE TO WIRE
Connector Name	TH80FW-CS1P-TM4	
Connector Type		

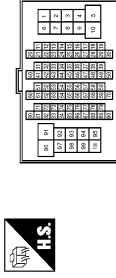

Terminal No.	Color of Wire	Signal Name [Specification]
62	W/L	
63	W/B	
96	Y	

JCLWM3507GB

PARKING, LICENSE PLATE, SIDE MARKER AND TAIL LAMPS SYSTEM

< DTC/CIRCUIT DIAGNOSIS >

PARKING, LICENSE PLATE, SIDE MARKER AND TAIL LAMPS SYSTEM

Wiring Diagram - PARKING, LICENSE PLATE, SIDE MARKER AND TAIL LAMPS -

INFOID:000000004992007

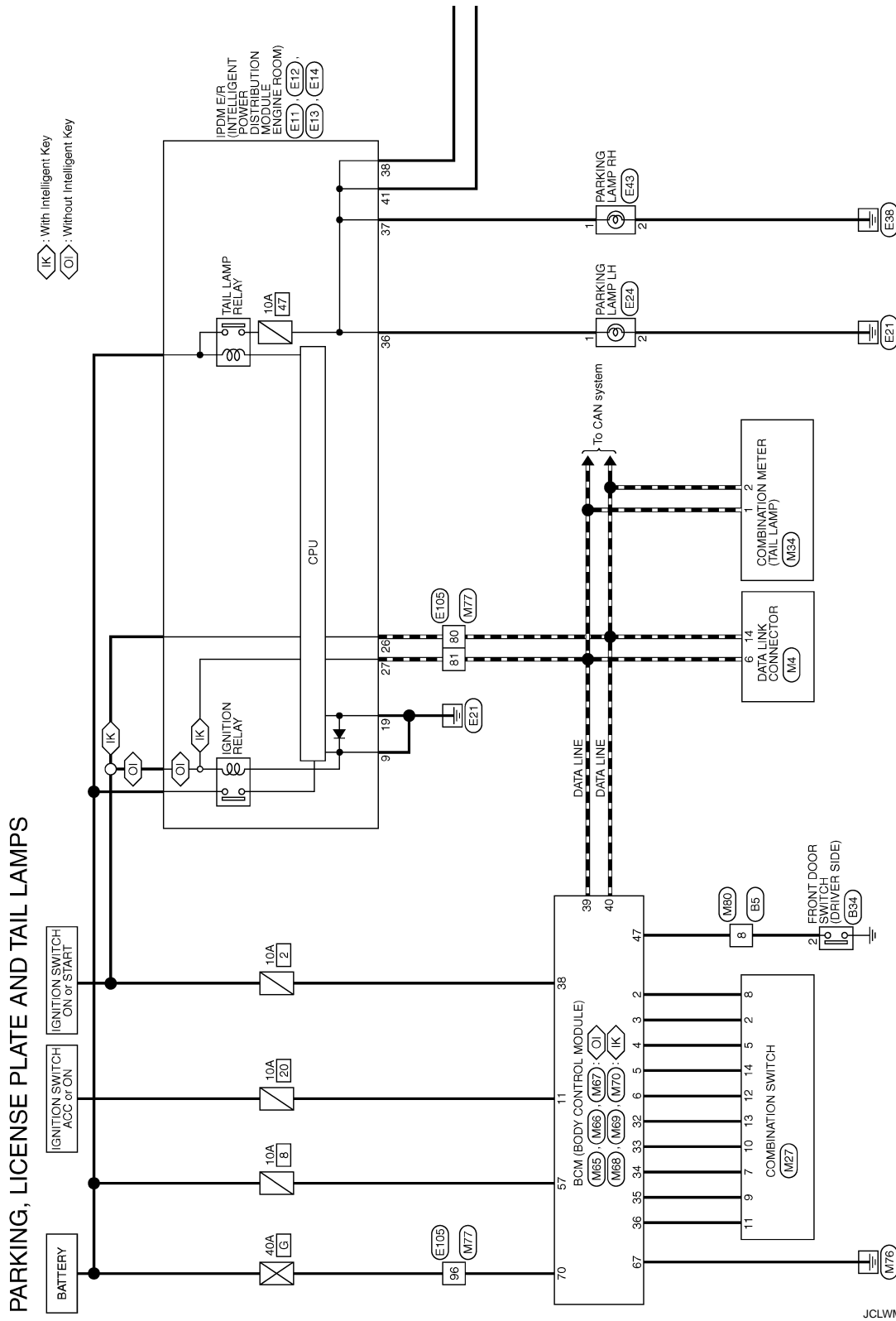

PARKING, LICENSE PLATE AND TAIL LAMPS

2009/02/27

JCLWM3514GB

A
B
C
D
E
F
G
H
I
J
K
EXL
M
N
O
P

PARKING, LICENSE PLATE, SIDE MARKER AND TAIL LAMPS SYSTEM

< DTC/CIRCUIT DIAGNOSIS >

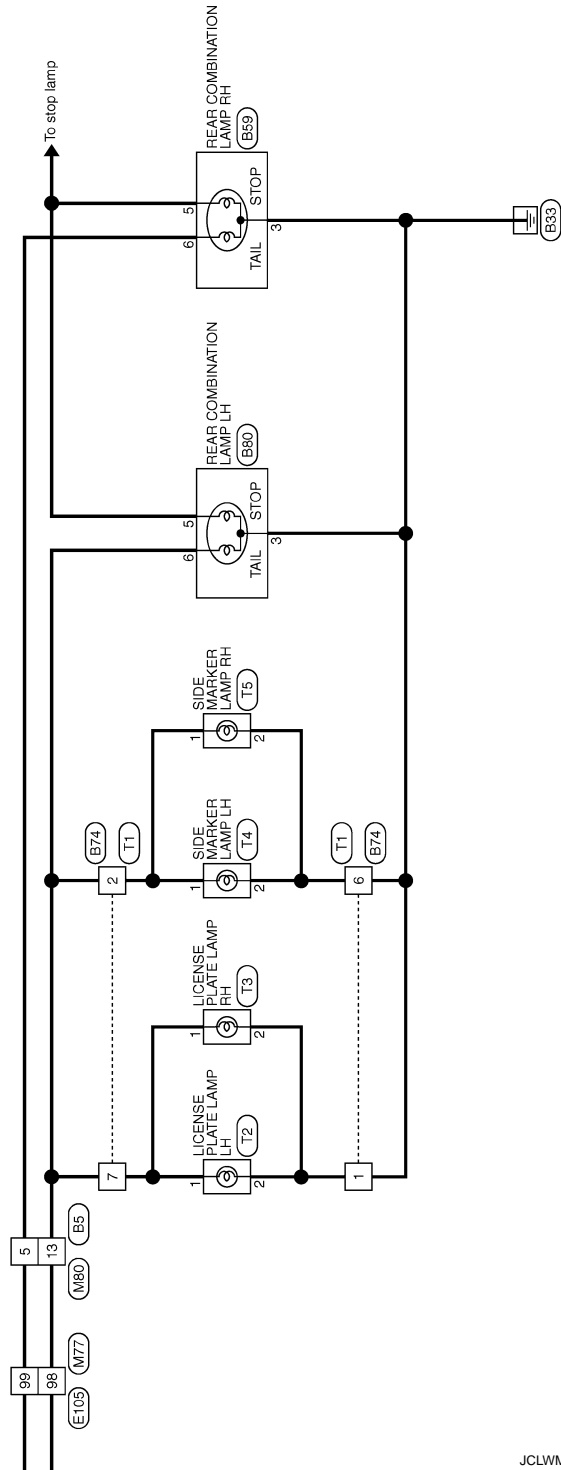















JCLWM3515GB

PARKING, LICENSE PLATE, SIDE MARKER AND TAIL LAMPS SYSTEM

< DTC/CIRCUIT DIAGNOSIS >

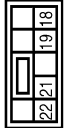
PARKING, LICENSE PLATE AND TAIL LAMPS

<table border="1"> <tr><td>Connector No.</td><td>B5</td></tr> <tr><td>Connector Name</td><td>WIRE TO WIRE</td></tr> <tr><td>Connector Type</td><td>TH16MW-NH</td></tr> </table>  	Connector No.	B5	Connector Name	WIRE TO WIRE	Connector Type	TH16MW-NH	<table border="1"> <tr><td>Terminal No.</td><td>Color of Wire</td><td>Signal Name [Specification]</td></tr> <tr><td>5</td><td>V</td><td>-</td></tr> <tr><td>8</td><td>LG</td><td>-</td></tr> <tr><td>13</td><td>GR</td><td>-</td></tr> </table>	Terminal No.	Color of Wire	Signal Name [Specification]	5	V	-	8	LG	-	13	GR	-			
Connector No.	B5																					
Connector Name	WIRE TO WIRE																					
Connector Type	TH16MW-NH																					
Terminal No.	Color of Wire	Signal Name [Specification]																				
5	V	-																				
8	LG	-																				
13	GR	-																				
<table border="1"> <tr><td>Connector No.</td><td>B54</td></tr> <tr><td>Connector Name</td><td>FRONT DOOR SWITCH (DRIVER SIDE)</td></tr> <tr><td>Connector Type</td><td>A03FW</td></tr> </table>  	Connector No.	B54	Connector Name	FRONT DOOR SWITCH (DRIVER SIDE)	Connector Type	A03FW	<table border="1"> <tr><td>Terminal No.</td><td>Color of Wire</td><td>Signal Name [Specification]</td></tr> <tr><td>2</td><td>LG</td><td>-</td></tr> </table>	Terminal No.	Color of Wire	Signal Name [Specification]	2	LG	-									
Connector No.	B54																					
Connector Name	FRONT DOOR SWITCH (DRIVER SIDE)																					
Connector Type	A03FW																					
Terminal No.	Color of Wire	Signal Name [Specification]																				
2	LG	-																				
<table border="1"> <tr><td>Connector No.</td><td>B59</td></tr> <tr><td>Connector Name</td><td>REAR COMBINATION LAMP RH</td></tr> <tr><td>Connector Type</td><td>RS08FB-PR</td></tr> </table>  	Connector No.	B59	Connector Name	REAR COMBINATION LAMP RH	Connector Type	RS08FB-PR	<table border="1"> <tr><td>Terminal No.</td><td>Color of Wire</td><td>Signal Name [Specification]</td></tr> <tr><td>3</td><td>B</td><td>-</td></tr> <tr><td>5</td><td>R</td><td>-</td></tr> <tr><td>6</td><td>V</td><td>-</td></tr> </table>	Terminal No.	Color of Wire	Signal Name [Specification]	3	B	-	5	R	-	6	V	-			
Connector No.	B59																					
Connector Name	REAR COMBINATION LAMP RH																					
Connector Type	RS08FB-PR																					
Terminal No.	Color of Wire	Signal Name [Specification]																				
3	B	-																				
5	R	-																				
6	V	-																				
<table border="1"> <tr><td>Connector No.</td><td>B74</td></tr> <tr><td>Connector Name</td><td>WIRE TO WIRE</td></tr> <tr><td>Connector Type</td><td>RH10FB</td></tr> </table>  	Connector No.	B74	Connector Name	WIRE TO WIRE	Connector Type	RH10FB	<table border="1"> <tr><td>Terminal No.</td><td>Color of Wire</td><td>Signal Name [Specification]</td></tr> <tr><td>1</td><td>B</td><td>-</td></tr> <tr><td>2</td><td>GR</td><td>-</td></tr> <tr><td>6</td><td>B</td><td>-</td></tr> <tr><td>7</td><td>GR</td><td>-</td></tr> </table>	Terminal No.	Color of Wire	Signal Name [Specification]	1	B	-	2	GR	-	6	B	-	7	GR	-
Connector No.	B74																					
Connector Name	WIRE TO WIRE																					
Connector Type	RH10FB																					
Terminal No.	Color of Wire	Signal Name [Specification]																				
1	B	-																				
2	GR	-																				
6	B	-																				
7	GR	-																				
<table border="1"> <tr><td>Connector No.</td><td>B80</td></tr> <tr><td>Connector Name</td><td>REAR COMBINATION LAMP LH</td></tr> <tr><td>Connector Type</td><td>RS08FB-PR</td></tr> </table>  	Connector No.	B80	Connector Name	REAR COMBINATION LAMP LH	Connector Type	RS08FB-PR	<table border="1"> <tr><td>Terminal No.</td><td>Color of Wire</td><td>Signal Name [Specification]</td></tr> <tr><td>3</td><td>B</td><td>-</td></tr> <tr><td>5</td><td>R</td><td>-</td></tr> <tr><td>6</td><td>GR</td><td>-</td></tr> </table>	Terminal No.	Color of Wire	Signal Name [Specification]	3	B	-	5	R	-	6	GR	-			
Connector No.	B80																					
Connector Name	REAR COMBINATION LAMP LH																					
Connector Type	RS08FB-PR																					
Terminal No.	Color of Wire	Signal Name [Specification]																				
3	B	-																				
5	R	-																				
6	GR	-																				
<table border="1"> <tr><td>Connector No.</td><td>E11</td></tr> <tr><td>Connector Name</td><td>IPDM E/R (INTELLIGENT POWER DISTRIBUTION MODULE ENGINE ROOM)</td></tr> <tr><td>Connector Type</td><td>M06FB-LG</td></tr> </table>  	Connector No.	E11	Connector Name	IPDM E/R (INTELLIGENT POWER DISTRIBUTION MODULE ENGINE ROOM)	Connector Type	M06FB-LG	<table border="1"> <tr><td>Terminal No.</td><td>Color of Wire</td><td>Signal Name [Specification]</td></tr> <tr><td>9</td><td>B/W</td><td>-</td></tr> </table>	Terminal No.	Color of Wire	Signal Name [Specification]	9	B/W	-									
Connector No.	E11																					
Connector Name	IPDM E/R (INTELLIGENT POWER DISTRIBUTION MODULE ENGINE ROOM)																					
Connector Type	M06FB-LG																					
Terminal No.	Color of Wire	Signal Name [Specification]																				
9	B/W	-																				
<table border="1"> <tr><td>Connector No.</td><td>E12</td></tr> <tr><td>Connector Name</td><td>IPDM E/R (INTELLIGENT POWER DISTRIBUTION MODULE ENGINE ROOM)</td></tr> <tr><td>Connector Type</td><td>NS08FB-CS</td></tr> </table>  	Connector No.	E12	Connector Name	IPDM E/R (INTELLIGENT POWER DISTRIBUTION MODULE ENGINE ROOM)	Connector Type	NS08FB-CS	<table border="1"> <tr><td>Terminal No.</td><td>Color of Wire</td><td>Signal Name [Specification]</td></tr> <tr><td>19</td><td>B/W</td><td>-</td></tr> </table>	Terminal No.	Color of Wire	Signal Name [Specification]	19	B/W	-									
Connector No.	E12																					
Connector Name	IPDM E/R (INTELLIGENT POWER DISTRIBUTION MODULE ENGINE ROOM)																					
Connector Type	NS08FB-CS																					
Terminal No.	Color of Wire	Signal Name [Specification]																				
19	B/W	-																				
<table border="1"> <tr><td>Connector No.</td><td>E13</td></tr> <tr><td>Connector Name</td><td>IPDM E/R (INTELLIGENT POWER DISTRIBUTION MODULE ENGINE ROOM)</td></tr> <tr><td>Connector Type</td><td>TH12FW-NH</td></tr> </table>  	Connector No.	E13	Connector Name	IPDM E/R (INTELLIGENT POWER DISTRIBUTION MODULE ENGINE ROOM)	Connector Type	TH12FW-NH	<table border="1"> <tr><td>Terminal No.</td><td>Color of Wire</td><td>Signal Name [Specification]</td></tr> <tr><td>26</td><td>P</td><td>-</td></tr> <tr><td>27</td><td>L</td><td>-</td></tr> </table>	Terminal No.	Color of Wire	Signal Name [Specification]	26	P	-	27	L	-						
Connector No.	E13																					
Connector Name	IPDM E/R (INTELLIGENT POWER DISTRIBUTION MODULE ENGINE ROOM)																					
Connector Type	TH12FW-NH																					
Terminal No.	Color of Wire	Signal Name [Specification]																				
26	P	-																				
27	L	-																				

JCLWM3516GB

A
B
C
D
E
F
G
H
I
J
K
L
M
N
O
P

EXL

PARKING, LICENSE PLATE, SIDE MARKER AND TAIL LAMPS SYSTEM

< DTC/CIRCUIT DIAGNOSIS >

PARKING, LICENSE PLATE AND TAIL LAMPS

Connector No.	E14
Connector Name	IPDM E/R (INTELLIGENT POWER DISTRIBUTION MODULE ENGINE ROOM)
Connector Type	HS12FER-CS

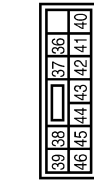

Terminal No.	Color of Wire	Signal Name [Specification]
36	O	-
37	V	-
38	G	-
41	SB	-

Connector No.	E24
Connector Name	PARKING LAMP LH
Connector Type	RK02FB



Terminal No.	Color of Wire	Signal Name [Specification]
1	Y	-
2	B/R	-

Connector No.	E43
Connector Name	PARKING LAMP RH
Connector Type	RK02FB



Terminal No.	Color of Wire	Signal Name [Specification]
1	V	-
2	B/Y	-

Connector No.	E105
Connector Name	WIRE TO WIRE
Connector Type	TH80MM-CS16-TM4

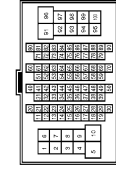

Terminal No.	Color of Wire	Signal Name [Specification]
80	P	-
81	L	-
86	LG	-
88	SB	-
89	G	-

Connector No.	M4
Connector Name	DATA LINK CONNECTOR
Connector Type	BD16FW

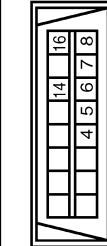

Terminal No.	Color of Wire	Signal Name [Specification]
6	L	-
14	P	-

Connector No.	M27
Connector Name	COMBINATION SWITCH
Connector Type	TH16FW-NH

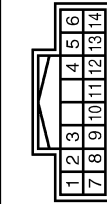

Terminal No.	Color of Wire	Signal Name [Specification]
2	GR	INPUT 4
5	L/Y	INPUT 3
7	W	OUTPUT 3
8	BR/W	INPUT 5
9	R/L	OUTPUT 2
10	Y/L	OUTPUT 4
11	L/O	OUTPUT 1
12	L/R	INPUT 1
13	LG	OUTPUT 5
14	G	INPUT 2

Connector No.	M34
Connector Name	COMBINATION METER
Connector Type	TH40FW-NH

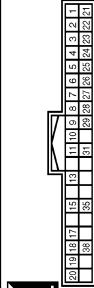

Terminal No.	Color of Wire	Signal Name [Specification]
1	L	CAN-H
2	P	CAN-L

PARKING, LICENSE PLATE, SIDE MARKER AND TAIL LAMPS SYSTEM

< DTC/CIRCUIT DIAGNOSIS >

PARKING, LICENSE PLATE AND TAIL LAMPS

Connector No.	M65
Connector Name	BCM (BODY CONTROL MODULE) (WITHOUT INTELLIGENT KEY)
Connector Type	TH40FB-NH



2	3	4	5	6	7	8	9	10	11	12	13	14	15	16	17	18	19	20	
21	22	23	24	25	26	27	28	29	30	31	32	33	34	35	36	37	38	39	40

Terminal No.	Color of Wire	Signal Name [Specification]
2	BR/W	COMBI SW INPUT 5
3	GR	COMBI SW INPUT 4
4	L/Y	COMBI SW INPUT 3
5	G	COMBI SW INPUT 2
6	L/R	COMBI SW INPUT 1
11	L/Y	ACC
32	LG	COMBI SW OUTPUT 5
33	Y/L	COMBI SW OUTPUT 4
34	W	COMBI SW OUTPUT 3
35	R/L	COMBI SW OUTPUT 2
36	L/O	COMBI SW OUTPUT 1

Connector No.	M68
Connector Name	BCM (BODY CONTROL MODULE) (WITHOUT INTELLIGENT KEY)
Connector Type	TH40FB-NH



2	3	4	5	6	7	8	9	10	11	12	13	14	15	16	17	18	19	20	
21	22	23	24	25	26	27	28	29	30	31	32	33	34	35	36	37	38	39	40

Terminal No.	Color of Wire	Signal Name [Specification]
2	BR/W	COMBI SW INPUT 5
3	GR	COMBI SW INPUT 4
4	L/Y	COMBI SW INPUT 3
5	G	COMBI SW INPUT 2
6	L/R	COMBI SW INPUT 1
11	L/Y	ACC F/B
32	LG	COMBI SW OUTPUT 5
33	Y/L	COMBI SW OUTPUT 4
34	W	COMBI SW OUTPUT 3
35	R/L	COMBI SW OUTPUT 2
36	L/O	COMBI SW OUTPUT 1

38	O	IGN F/B
39	L	CAN-H
40	P	CAN-L

Connector No.	M66
Connector Name	BCM (BODY CONTROL MODULE) (WITHOUT INTELLIGENT KEY)
Connector Type	FEA09FW-FHA6-SA



50	43	44	45	46	47	48	49	54
----	----	----	----	----	----	----	----	----

Terminal No.	Color of Wire	Signal Name [Specification]
47	BR/Y	DRIVER DOOR SW

38	O	IGN F/B
39	L	CAN-H
40	P	CAN-L

Connector No.	M69
Connector Name	BCM (BODY CONTROL MODULE) (WITHOUT INTELLIGENT KEY)
Connector Type	FEA09FW-FHA6-SA



50	43	44	45	46	47	48	49	54	55
----	----	----	----	----	----	----	----	----	----

Terminal No.	Color of Wire	Signal Name [Specification]
47	BR/Y	DRIVER DOOR SW

Connector No.	M67
Connector Name	BCM (BODY CONTROL MODULE) (WITHOUT INTELLIGENT KEY)
Connector Type	FEA09FB-FHA6-SA



56	57	59	60	61	63
65	66	67	68	69	70

Terminal No.	Color of Wire	Signal Name [Specification]
57	Y	BAT (FUSE)
67	B	GND
70	Y	BAT (F/L)

Connector No.	M70
Connector Name	BCM (BODY CONTROL MODULE) (WITHOUT INTELLIGENT KEY)
Connector Type	FEA09FB-FHA6-SA



56	57	59	60	61	63
65	66	67	68	69	70

Terminal No.	Color of Wire	Signal Name [Specification]
57	Y	BAT (FUSE)
67	B	GND
70	Y	BAT (F/L)

A
B
C
D
E
F
G
H
I
J
K
EXL
M
N
O
P

JCLWM3518GB

PARKING, LICENSE PLATE, SIDE MARKER AND TAIL LAMPS SYSTEM

< DTC/CIRCUIT DIAGNOSIS >

PARKING, LICENSE PLATE AND TAIL LAMPS

Connector No.	M80	Connector No.	T2
Connector Name	WIRE TO WIRE	Connector Name	LICENSE PLATE LAMP LH
Connector Type	T11EFW-NH	Connector Type	RK02FBR

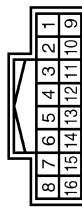
Terminal No.	Color of Wire	Signal Name [Specification]
5	W	-
8	BR/Y	-
13	BR/W	-

Connector No.	T1	Connector No.	T5
Connector Name	WIRE TO WIRE	Connector Name	SIDE MARKER LAMP RH
Connector Type	RH10MB	Connector Type	HS02FG-W

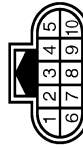

Terminal No.	Color of Wire	Signal Name [Specification]
1	BR	-
2	GR	-
6	B	-
7	W	-

Connector No.	M80	Connector No.	T4
Connector Name	WIRE TO WIRE	Connector Name	SIDE MARKER LAMP LH
Connector Type	T11EFW-NH	Connector Type	HS02FG-W

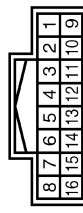

Terminal No.	Color of Wire	Signal Name [Specification]
5	W	-
8	BR/Y	-
13	BR/W	-

Connector No.	M77	Connector No.	T3
Connector Name	WIRE TO WIRE	Connector Name	LICENSE PLATE LAMP RH
Connector Type	TH80TY-CS16-TM4	Connector Type	RK02FBR



Terminal No.	Color of Wire	Signal Name [Specification]
80	P	-
81	L	-
96	Y	-
98	BR/W	-
99	W	-

Connector No.	T5	Connector No.	T2
Connector Name	SIDE MARKER LAMP RH	Connector Name	LICENSE PLATE LAMP LH
Connector Type	HS02FG-W	Connector Type	RK02FBR



Terminal No.	Color of Wire	Signal Name [Specification]
1	GR	-
2	B	-

Connector No.	T4	Connector No.	T3
Connector Name	SIDE MARKER LAMP LH	Connector Name	LICENSE PLATE LAMP RH
Connector Type	HS02FG-W	Connector Type	RK02FBR

Terminal No.	Color of Wire	Signal Name [Specification]
1	GR	-
2	B	-

Connector No.	T3	Connector No.	T2
Connector Name	LICENSE PLATE LAMP RH	Connector Name	LICENSE PLATE LAMP LH
Connector Type	RK02FBR	Connector Type	RK02FBR

Terminal No.	Color of Wire	Signal Name [Specification]
1	GR	-
2	B	-

JCLWM3519GB

STOP LAMP

< DTC/CIRCUIT DIAGNOSIS >

STOP LAMP

Wiring Diagram - STOP LAMP -

INFOID:000000004992013

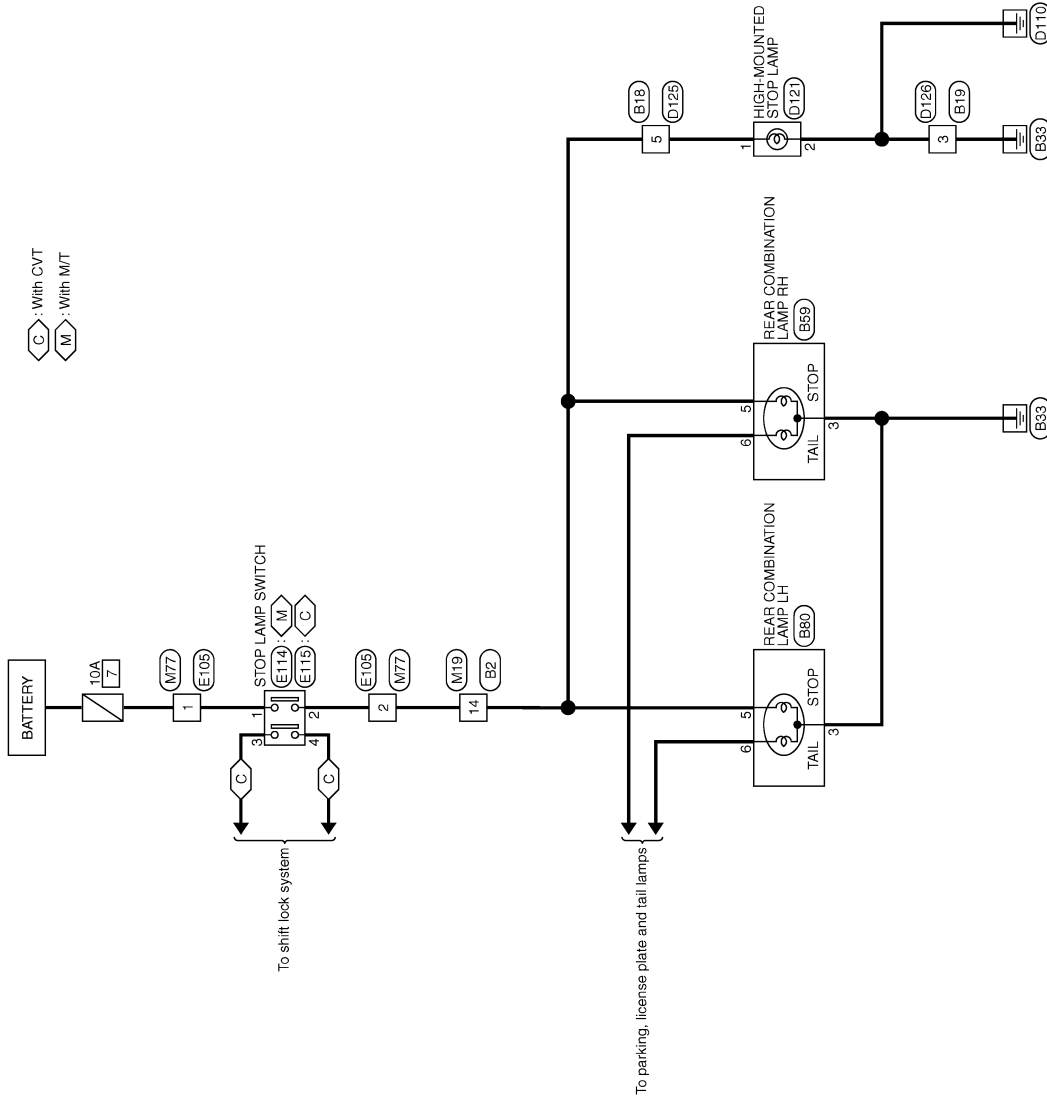

STOP LAMP

2009/02/27

JCLWM3508GB

A
B
C
D
E
F
G
H
I
J
K
EXL
M
N
O
P

STOP LAMP

< DTC/CIRCUIT DIAGNOSIS >

STOP LAMP

Connector No.	B2
Connector Name	WIRE TO WIRE
Connector Type	HS16MW-CS

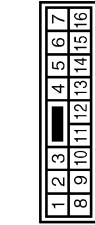

Terminal No.	Color of Wire	Signal Name [Specification]
14	R	-

Connector No.	B18
Connector Name	WIRE TO WIRE
Connector Type	NH10MW-CS10

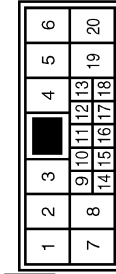

Terminal No.	Color of Wire	Signal Name [Specification]
5	R	-

Connector No.	B19
Connector Name	WIRE TO WIRE
Connector Type	M04MW-LC



Terminal No.	Color of Wire	Signal Name [Specification]
3	B	-

Connector No.	B39
Connector Name	REAR COMBINATION LAMP RH
Connector Type	RS06FB-PR



Terminal No.	Color of Wire	Signal Name [Specification]
3	B	-
5	R	-
6	V	-

Connector No.	B80
Connector Name	REAR COMBINATION LAMP LH
Connector Type	RS06FB-PR

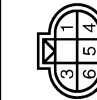

Terminal No.	Color of Wire	Signal Name [Specification]
3	B	-
5	R	-
6	GR	-

Connector No.	D121
Connector Name	HIGH-MOUNTED STOP LAMP
Connector Type	HS02FG-W



Terminal No.	Color of Wire	Signal Name [Specification]
1	GR	-
2	B	-

Connector No.	D125
Connector Name	WIRE TO WIRE
Connector Type	NH10FW-CS10

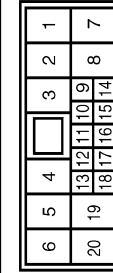

Terminal No.	Color of Wire	Signal Name [Specification]
5	GR	-

Connector No.	D126
Connector Name	WIRE TO WIRE
Connector Type	M04FW-LC



Terminal No.	Color of Wire	Signal Name [Specification]
3	B	-

JCLWM3509GB

STOP LAMP

< DTC/CIRCUIT DIAGNOSIS >

STOP LAMP

Connector No.	E105
Connector Name	WIRE TO WIRE
Connector Type	TH80FW-CS16-TM4

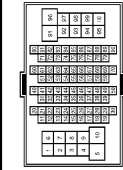

Terminal No.	Color of Wire	Signal Name [Specification]
1	V	
2	W	

Connector No.	M77
Connector Name	WIRE TO WIRE
Connector Type	TH80FW-CS16-TM4

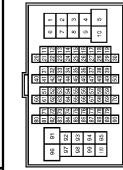

Terminal No.	Color of Wire	Signal Name [Specification]
1	B/O	
2	R	

Connector No.	E114
Connector Name	STOP LAMP SWITCH (WITH M/T)
Connector Type	M02FB-LC



Terminal No.	Color of Wire	Signal Name [Specification]
1	V	
2	W	

Connector No.	E115
Connector Name	STOP LAMP SWITCH (WITH CVT)
Connector Type	M04FF-LC

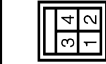

Terminal No.	Color of Wire	Signal Name [Specification]
1	V	
2	W	
3	O	
4	G	

Connector No.	M19
Connector Name	WIRE TO WIRE
Connector Type	NS18FW-CS



Terminal No.	Color of Wire	Signal Name [Specification]
14	R	

A
B
C
D
E
F
G
H
I
J
K
EXL
M
N
O
P

BACK-UP LAMP

< DTC/CIRCUIT DIAGNOSIS >

BACK-UP LAMP

Wiring Diagram - BACK-UP LAMP -

INFOID:000000004992014

BACK-UP LAMP

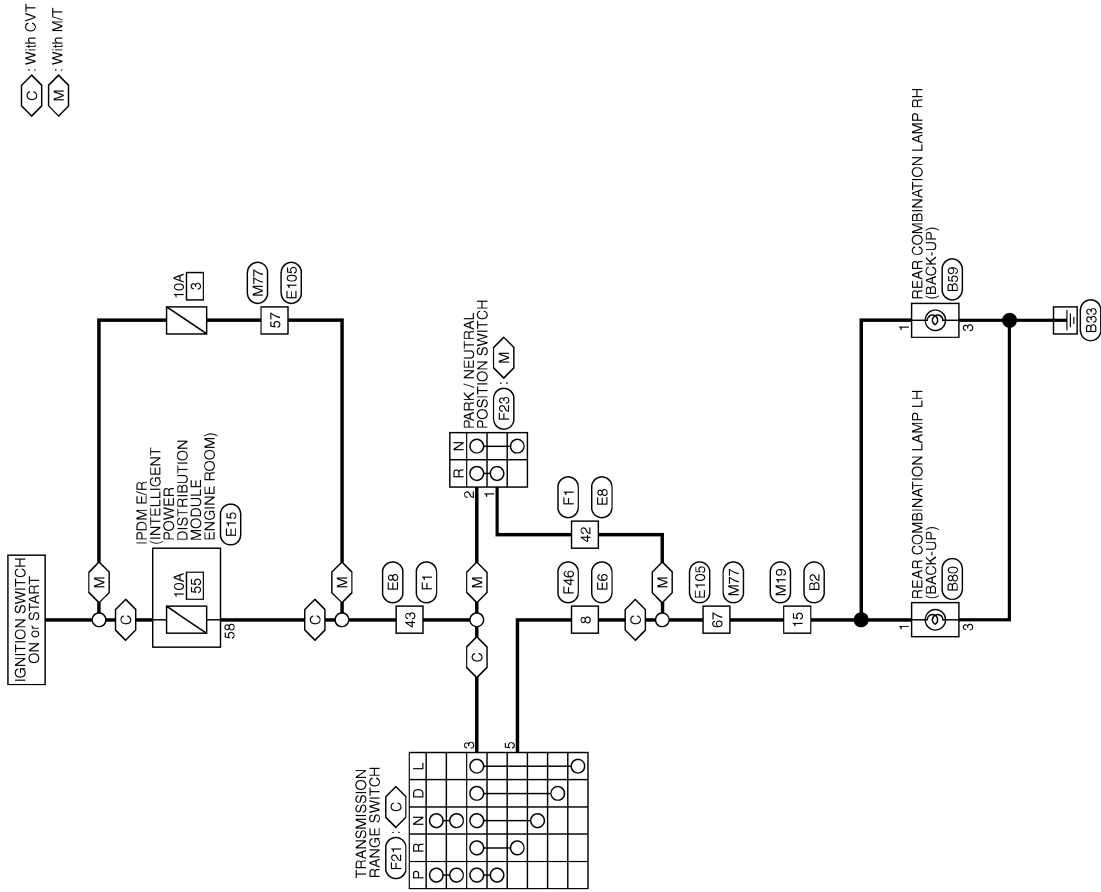

2009/02/27

JCLWM3511GB

BACK-UP LAMP

< DTC/CIRCUIT DIAGNOSIS >

BACK-UP LAMP

Connector No. B2	WIRE TO WIRE	NS16MW-CS		Terminal No. 15	Color of Wire Y	Signal Name [Specification]	
Connector No. E6	WIRE TO WIRE	RH1ZFB		Terminal No. 8	Color of Wire GR	Signal Name [Specification]	
Connector No. B30	REAR COMBINATION LAMP LH	RS08FB-PR		Terminal No. 1	Color of Wire Y	Signal Name [Specification]	
Connector No. E105	WIRE TO WIRE	TH80MW-CS16-TM4		Terminal No. 3	Color of Wire B	Signal Name [Specification]	
Connector No. E59	REAR COMBINATION LAMP RH	RS08FB-PR		Terminal No. 1	Color of Wire Y	Signal Name [Specification]	
Connector No. E15	IPDM E/R (INTELLIGENT POWER DISTRIBUTION MODULE ENGINE ROOM)	NS10FW-CS		Terminal No. 58	Color of Wire R	Signal Name [Specification] -[With CVT]	
Connector No. E1	WIRE TO WIRE	SAA38FB-RS10-SJZZ		Terminal No. 42	Color of Wire V	Signal Name [Specification] -[With CVT]	
Connector No. E8	WIRE TO WIRE	SAA38MB-RS10-SJZZ		Terminal No. 43	Color of Wire LG	Signal Name [Specification] -[With M/T]	
Connector No. F1	WIRE TO WIRE	SAA38FB-RS10-SJZZ		Terminal No. 42	Color of Wire G	Signal Name [Specification]	
Connector No. F1	WIRE TO WIRE	SAA38FB-RS10-SJZZ		Terminal No. 43	Color of Wire R	Signal Name [Specification]	

JCLWM3512GB

A
B
C
D
E
F
G
H
I
J
K
EXL
M
N
O
P

BACK-UP LAMP

< DTC/CIRCUIT DIAGNOSIS >

BACK-UP LAMP

Connector No.	F21
Connector Name	TRANSMISSION RANGE SWITCH
Connector Type	RK0BFG



Terminal No.	Color of Wire	Signal Name [Specification]
3	R	-
5	SB	-

Connector No.	F23
Connector Name	PARK / NEUTRAL POSITION SWITCH
Connector Type	FEA0BFG



Terminal No.	Color of Wire	Signal Name [Specification]
1	G	-
2	R	-

Connector No.	F46
Connector Name	WIRE TO WIRE
Connector Type	RH2MB

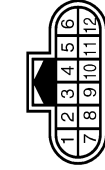

Terminal No.	Color of Wire	Signal Name [Specification]
8	SB	-

Connector No.	M19
Connector Name	WIRE TO WIRE
Connector Type	NSJ6FW-CS



Terminal No.	Color of Wire	Signal Name [Specification]
15	Y/R	-

Connector No.	M77
Connector Name	WIRE TO WIRE
Connector Type	TH60FW-CS16-TM4



Terminal No.	Color of Wire	Signal Name [Specification]
57	GR	-
67	Y/R	-

JCLWM3513GB

BCM (BODY CONTROL MODULE)

< ECU DIAGNOSIS INFORMATION >

ECU DIAGNOSIS INFORMATION

BCM (BODY CONTROL MODULE)

WITH INTELLIGENT KEY

WITH INTELLIGENT KEY : Reference Value

INFOID:000000005185901

VALUES ON THE DIAGNOSIS TOOL

CONSULT-III MONITOR ITEM

Monitor Item	Condition	Value/Status
FR WIPER HI	Other than front wiper switch HI	Off
	Front wiper switch HI	On
FR WIPER LOW	Other than front wiper switch LO	Off
	Front wiper switch LO	On
FR WASHER SW	Front washer switch OFF	Off
	Front washer switch ON	On
FR WIPER INT	Other than front wiper switch INT/AUTO	Off
	Front wiper switch INT/AUTO	On
FR WIPER STOP	Front wiper is not in STOP position	Off
	Front wiper is in STOP position	On
INT VOLUME	Wiper intermittent dial is in a dial position 1 - 7	Wiper intermittent dial position
RR WIPER ON	Other than rear wiper switch ON	Off
	Rear wiper switch ON	On
RR WIPER INT	Other than rear wiper switch INT	Off
	Rear wiper switch INT	On
RR WASHER SW	Rear washer switch OFF	Off
	Rear washer switch ON	On
RR WIPER STOP	Rear wiper is in STOP position	Off
	Rear wiper is not in STOP position	On
TURN SIGNAL R	Other than turn signal switch RH	Off
	Turn signal switch RH	On
TURN SIGNAL L	Other than turn signal switch LH	Off
	Turn signal switch LH	On
TAIL LAMP SW	Other than lighting switch 1ST and 2ND	Off
	Lighting switch 1ST or 2ND	On
HI BEAM SW	Other than lighting switch HI	Off
	Lighting switch HI	On
HEAD LAMP SW 1	Other than lighting switch 2ND	Off
	Lighting switch 2ND	On
HEAD LAMP SW 2	Other than lighting switch 2ND	Off
	Lighting switch 2ND	On
PASSING SW	Other than lighting switch PASS	Off
	Lighting switch PASS	On
AUTO LIGHT SW	Other than lighting switch AUTO	Off
	Lighting switch AUTO	On

A

B

C

D

E

F

G

H

I

J

K

EXL

M

N

O

P

BCM (BODY CONTROL MODULE)

< ECU DIAGNOSIS INFORMATION >

Monitor Item	Condition	Value/Status
FR FOG SW	Front fog lamp switch OFF	Off
	Front fog lamp switch ON	On
DOOR SW-DR	Driver door closed	Off
	Driver door opened	On
DOOR SW-AS	Passenger door closed	Off
	Passenger door opened	On
DOOR SW-RR	Rear RH door closed	Off
	Rear RH door opened	On
DOOR SW-RL	Rear LH door closed	Off
	Rear LH door opened	On
DOOR SW-BK	Back door closed	Off
	Back door opened	On
CDL LOCK SW	Other than power door lock switch LOCK	Off
	Power door lock switch LOCK	On
CDL UNLOCK SW	Other than power door lock switch UNLOCK	Off
	Power door lock switch UNLOCK	On
KEY CYL LK-SW	Other than driver door key cylinder LOCK position	Off
	Driver door key cylinder LOCK position	On
KEY CYL UN-SW	Other than driver door key cylinder UNLOCK position	Off
	Driver door key cylinder UNLOCK position	On
HAZARD SW	Hazard switch is OFF	Off
	Hazard switch is ON	On
REAR DEF SW	Rear window defogger switch OFF	Off
	Rear window defogger switch ON	On
TR/BD OPEN SW	NOTE: The item is indicated, but not monitored.	Off
TRNK/HAT MNTR	NOTE: The item is indicated, but not monitored.	Off
FAN ON SIG	Blower fan OFF	Off
	Blower fan ON	On
AIR COND SW	Air conditioner OFF (A/C switch indicator OFF)	Off
	Air conditioner ON (A/C switch indicator ON)	On
RKE-LOCK	LOCK button of the key is not pressed	Off
	LOCK button of the key is pressed	On
RKE-UNLOCK	UNLOCK button of the key is not pressed	Off
	UNLOCK button of the key is pressed	On
RKE-TR/BD	BACK DOOR OPEN button of the key is not pressed	Off
	BACK DOOR OPEN button of the key is pressed	On
RKE-PANIC	PANIC button of the key is not pressed	Off
	PANIC button of the key is pressed	On
RKE-MODE CHG	LOCK/UNLOCK button of the key is not pressed and held simultaneously	Off
	LOCK/UNLOCK button of the key is pressed and held simultaneously	On
OPTI SEN (DTCT)	Bright outside of the vehicle	Close to 5 V
	Dark outside of the vehicle	Close to 0 V

BCM (BODY CONTROL MODULE)

< ECU DIAGNOSIS INFORMATION >

Monitor Item	Condition	Value/Status	
OPTI SEN (FILT)	Bright outside of the vehicle (Lighting switch AUTO)	Close to 5 V	A
	Dark outside of the vehicle (Lighting switch AUTO)	Close to 1.50 V	
OPTICAL SENSOR	NOTE: The item is indicated, but not monitored.	Off	B
RAIN SENSOR	NOTE: The item is indicated, but not monitored.	Off	C
REQ SW -DR	Driver door request switch is not pressed	Off	
	Driver door request switch is pressed	On	
REQ SW -AS	Passenger door request switch is not pressed	Off	D
	Passenger door request switch is pressed	On	
REQ SW -RR	NOTE: The item is indicated, but not monitored.	Off	E
REQ SW -RL	NOTE: The item is indicated, but not monitored.	Off	
REQ SW -BD/TR	Back door request switch is not pressed	Off	F
	Back door request switch is pressed	On	
PUSH SW	Push-button ignition switch (push switch) is not pressed	Off	G
	Push-button ignition switch (push switch) is pressed	On	
CLUCH SW	NOTE: The item is indicated, but not monitored.	Off	H
BRAKE SW 1	The brake pedal is not depressed	Off	
	The brake pedal is depressed	On	
BRAKE SW 2	The brake pedal is depressed when No. 7 fuse is blown	Off	I
	The brake pedal is not depressed when No. 7 fuse is blown, or No. 7 fuse is normal	On	
DETE/CANCL SW	Selector lever in P position	Off	J
	Selector lever in any position other than P	On	
SFT PN/N SW	Selector lever in any position other than P and N	Off	K
	Selector lever in P or N position	On	
S/L -LOCK	Steering is locked	Off	EXL
	Steering is unlocked	On	
S/L -UNLOCK	Steering is unlocked	Off	
	Steering is locked	On	M
S/L RELAY-F/B	Steering is unlocked	Off	
	Steering is locked	On	
UNLK SEN -DR	Driver door is locked	Off	N
	Driver door is unlocked	On	
PUSH SW -IPDM	Push-button ignition switch (push-switch) is not pressed	Off	O
	Push-button ignition switch (push-switch) is pressed	On	
IGN RLY1 -F/B	Ignition switch in OFF or ACC position	Off	
	Ignition switch in ON position	On	P
DETE SW -IPDM	Selector lever in any position other than P	Off	
	Selector lever in P position	On	
SFT PN -IPDM	Selector lever in any position other than P and N	Off	
	Selector lever in P or N position	On	

BCM (BODY CONTROL MODULE)

< ECU DIAGNOSIS INFORMATION >

Monitor Item	Condition	Value/Status
SFT P -MET	Selector lever in any position other than P	Off
	Selector lever in P position	On
SFT N -MET	Selector lever in any position other than N	Off
	Selector lever in N position	On
ENGINE STATE	Engine stopped	Stop
	While the engine stalls	Stall
	At engine cranking	Crank
	Engine running	Run
S/L LOCK-IPDM	Steering is locked	Off
	Steering is unlocked	On
S/L UNLK-IPDM	Steering is unlocked	Off
	Steering is locked	On
S/L RELAY-REQ	Steering is unlocked	Off
	Steering is locked	On
VEH SPEED 1	While driving	Equivalent to speedometer reading
VEH SPEED 2	While driving	Equivalent to speedometer reading
DOOR STAT-DR	Driver door is locked	LOCK
	Wait with selective UNLOCK operation (5 seconds)	READY
	Driver door is unlocked	UNLOCK
DOOR STAT-AS	Passenger door is locked	LOCK
	Wait with selective UNLOCK operation (5 seconds)	READY
	Passenger door is unlocked	UNLOCK
ID OK FLAG	Steering is locked	Reset
	Steering is unlocked	Set
PRMT ENG STRT	The engine start is prohibited	Reset
	The engine start is permitted	Set
PRMT RKE STRT	NOTE: The item is indicated, but not monitored.	Reset
RKE OPE COUN1	During the operation of the key	Operation frequency of the key
RKE OPE COUN2	NOTE: The item is indicated, but not monitored.	—
CONFIRM ID ALL	The key ID that the key slot receives is not recognized by any key ID registered to BCM.	Yet
	The key ID that the key slot receives is recognized by any key ID registered to BCM.	Done
CONFIRM ID4	The key ID that the key slot receives is not recognized by the fourth key ID registered to BCM.	Yet
	The key ID that the key slot receives is recognized by the fourth key ID registered to BCM.	Done
CONFIRM ID3	The key ID that the key slot receives is not recognized by the third key ID registered to BCM.	Yet
	The key ID that the key slot receives is recognized by the third key ID registered to BCM.	Done

BCM (BODY CONTROL MODULE)

< ECU DIAGNOSIS INFORMATION >

Monitor Item	Condition	Value/Status	
CONFIRM ID2	The key ID that the key slot receives is not recognized by the second key ID registered to BCM.	Yet	A
	The key ID that the key slot receives is recognized by the second key ID registered to BCM.	Done	B
CONFIRM ID1	The key ID that the key slot receives is not recognized by the first key ID registered to BCM.	Yet	C
	The key ID that the key slot receives is recognized by the first key ID registered to BCM.	Done	
NOT REGISTERED	BCM detects registered key ID, or BCM does not detect key ID.	ID OK	D
	BCM detects non-registration key ID.	ID NG	
TP 4	The ID of fourth key is not registered to BCM	Yet	E
	The ID of fourth key is registered to BCM	Done	
TP 3	The ID of third key is not registered to BCM	Yet	F
	The ID of third key is registered to BCM	Done	
TP 2	The ID of second key is not registered to BCM	Yet	G
	The ID of second key is registered to BCM	Done	
TP 1	The ID of first key is not registered to BCM	Yet	H
	The ID of first key is registered to BCM	Done	
AIR PRESS FL	Ignition switch ON (Only when the signal from the transmitter is received)	Air pressure of front LH tire	I
AIR PRESS FR	Ignition switch ON (Only when the signal from the transmitter is received)	Air pressure of front RH tire	J
AIR PRESS RR	Ignition switch ON (Only when the signal from the transmitter is received)	Air pressure of rear RH tire	K
AIR PRESS RL	Ignition switch ON (Only when the signal from the transmitter is received)	Air pressure of rear LH tire	EXL
ID REGST FL1	ID of front LH tire transmitter is registered	Done	
	ID of front LH tire transmitter is not registered	Yet	
ID REGST FR1	ID of front RH tire transmitter is registered	Done	
	ID of front RH tire transmitter is not registered	Yet	
ID REGST RR1	ID of rear RH tire transmitter is registered	Done	
	ID of rear RH tire transmitter is not registered	Yet	
ID REGST RL1	ID of rear LH tire transmitter is registered	Done	
	ID of rear LH tire transmitter is not registered	Yet	M
WARNING LAMP	Tire pressure indicator OFF	Off	
	Tire pressure indicator ON	On	
BUZZER	Tire pressure warning alarm is not sounding	Off	N
	Tire pressure warning alarm is sounding	On	O

BCM (BODY CONTROL MODULE)

< ECU DIAGNOSIS INFORMATION >

TERMINAL LAYOUT

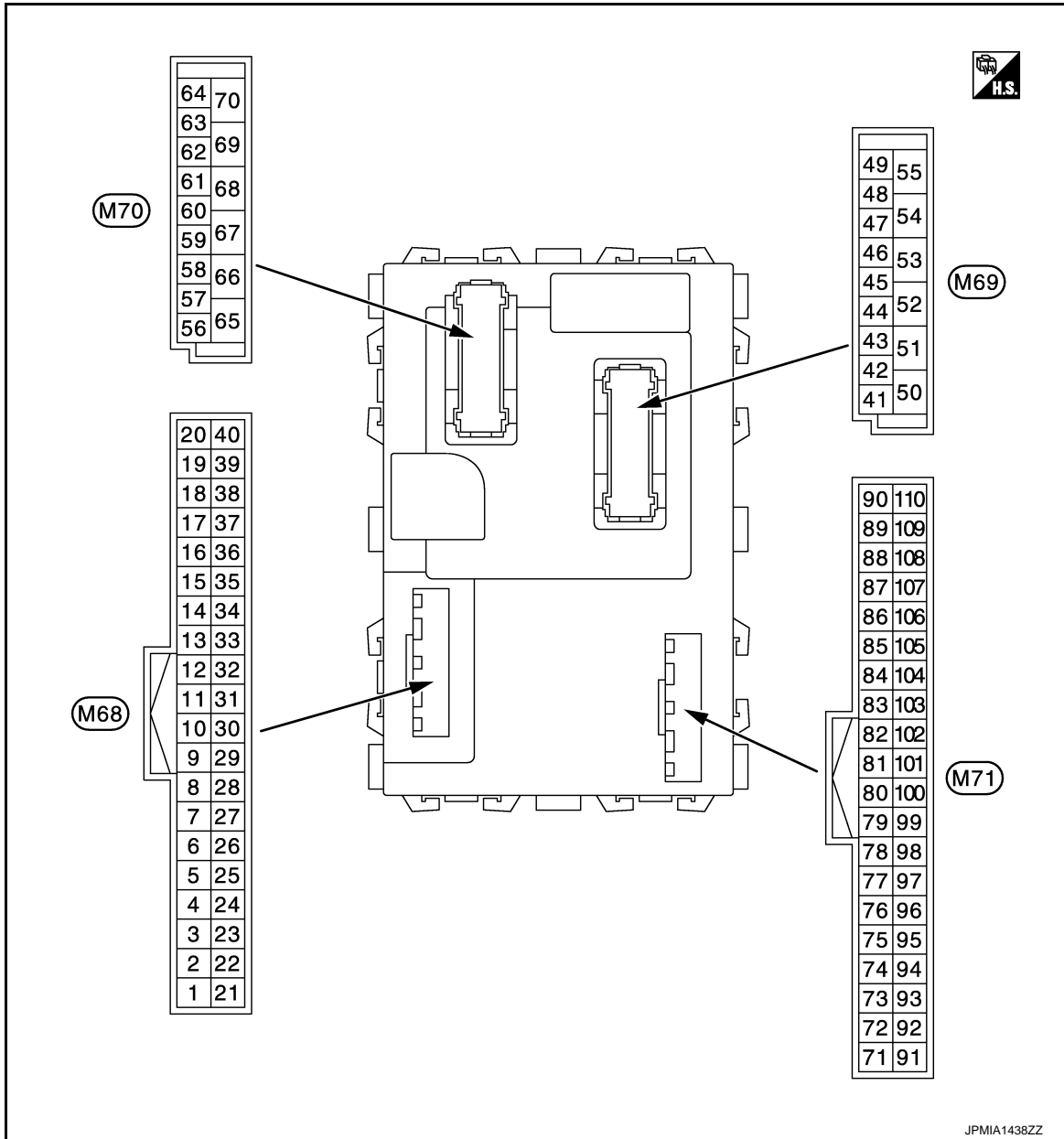

BCM (BODY CONTROL MODULE)

< ECU DIAGNOSIS INFORMATION >

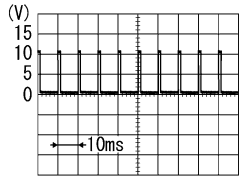
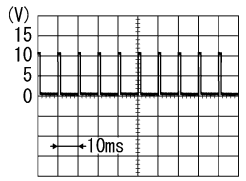
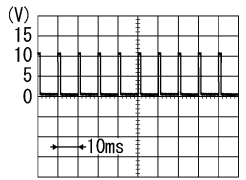
Terminal No. (Wire color)		Description		Condition	Value (Approx.)	
		Signal name	Input/ Output			
+	-					
2 (BR/W)	Ground	Combination switch INPUT 5	Input	Combination switch (Wiper intermittent dial 4)	All switch OFF	0 V
					Turn signal switch RH	
					Lighting switch HI	
					Lighting switch 1ST	
					Lighting switch 2ND	
					1.0 V	
3 (GR)	Ground	Combination switch INPUT 4	Input	Combination switch (Wiper intermittent dial 4)	All switch OFF	0 V
					Turn signal switch LH	
					Lighting switch PASS	
					Lighting switch 2ND	
					Front fog lamp switch ON	
					1.0 V	
4 (L/Y)	Ground	Combination switch INPUT 3	Input	Combination switch (Wiper intermittent dial 4)	All switch OFF	0 V
					Front wiper switch LO	
					Front wiper switch MIST	
					Front wiper switch INT	
					Lighting switch AUTO	
					1.0 V	

A
B
C
D
E
F
G
H
I
J
K
L
M
N
O
P

EXL

BCM (BODY CONTROL MODULE)

< ECU DIAGNOSIS INFORMATION >

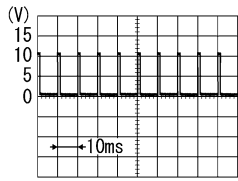
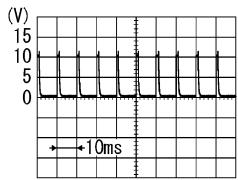
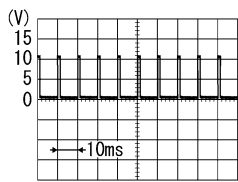
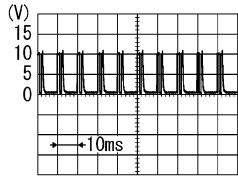
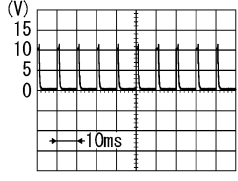
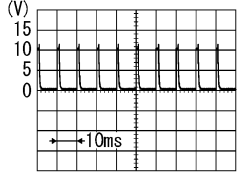
Terminal No. (Wire color)		Description		Condition	Value (Approx.)					
+	-	Signal name	Input/ Output							
5 (G)	Ground	Combination switch INPUT 2	Input	Combination switch	All switch OFF (Wiper intermittent dial 4)	0 V				
					Front washer switch (Wiper intermittent dial 4)					
					Rear washer ON (Wiper intermittent dial 4)					
					Any of the condition below with all switch OFF <ul style="list-style-type: none"> • Wiper intermittent dial 1 • Wiper intermittent dial 5 • Wiper intermittent dial 6 					
				Rear wiper switch ON (Wiper intermittent dial 4)		1.0 V <small>PKIB4958J</small>				
6 (L/R)	Ground	Combination switch INPUT 1	Input	Combination switch	All switch OFF (Wiper intermittent dial 4)	0 V				
					Front wiper switch HI (Wiper intermittent dial 4)					
					Rear wiper switch INT (Wiper intermittent dial 4)					
					Wiper intermittent dial 3 (All switch OFF)					
								Any of the condition below with all switch OFF <ul style="list-style-type: none"> • Wiper intermittent dial 1 • Wiper intermittent dial 2 		1.0 V <small>PKIB4958J</small>
								Any of the condition below with all switch OFF <ul style="list-style-type: none"> • Wiper intermittent dial 6 • Wiper intermittent dial 7 		1.9 V <small>PKIB4952J</small>
						0.8 V <small>PKIB4956J</small>				

BCM (BODY CONTROL MODULE)

< ECU DIAGNOSIS INFORMATION >

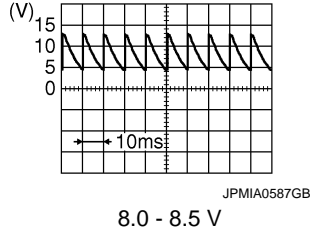
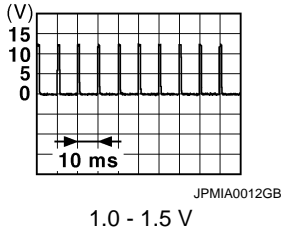
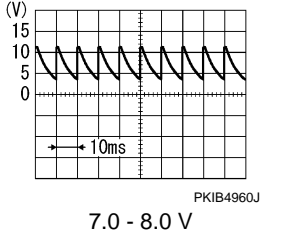
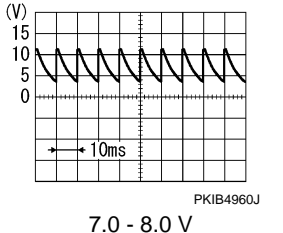
Terminal No. (Wire color)		Description		Condition	Value (Approx.)	
+	-	Signal name	Input/ Output			
7 (W/R)	Ground	Door key cylinder switch UNLOCK	Input	Door key cylinder switch	NEUTRAL position	
				UNLOCK position	0 V	
8 (W/B)	Ground	Door key cylinder switch LOCK	Input	Door key cylinder switch	NEUTRAL position	12 V
				LOCK position	0 V	
9 (R)	Ground	Stop lamp switch 1	Input	Stop lamp switch	OFF (Brake pedal is not depressed)	0 V
				ON (Brake pedal is de- pressed)	Battery voltage	
10 (V/W)	Ground	Tire pressure warn- ing check switch	Input	Ignition switch OFF	Ignition switch OFF	
				Ignition switch ACC or ON	Battery voltage	
11 (L/Y)	Ground	ACC feedback	Input	Ignition switch OFF	0 V	
				Ignition switch ACC or ON	Battery voltage	
12 (SB)	Ground	Passenger door switch	Input	Passenger door switch	OFF (When passenger door closed)	
				ON (When passenger door opened)	0 V	
13 (GR/L)	Ground	Rear RH door switch	Input	Rear RH door switch	OFF (When rear RH door closed)	
				ON (When rear RH door opened)	0 V	
14 (L/B)	Ground	Optical sensor	Input	Ignition switch ON	When bright outside of the vehicle	Close to 5 V
				When dark outside of the vehicle	Close to 0 V	

A
B
C
D
E
F
G
H
I
J
K
M
N
O
P

EXL

BCM (BODY CONTROL MODULE)

< ECU DIAGNOSIS INFORMATION >

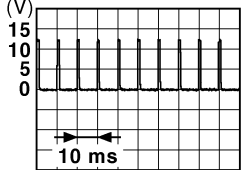
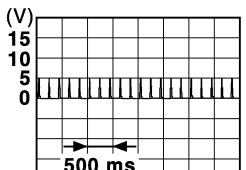
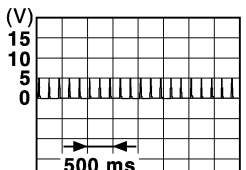
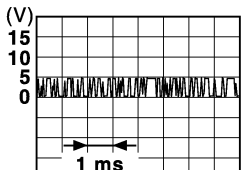
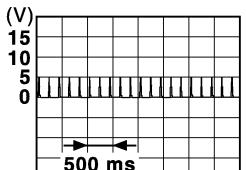
Terminal No. (Wire color)		Description		Condition		Value (Approx.)
+	-	Signal name	Input/ Output			
15 (W/L)	Ground	Rear window defogger switch	Input	Rear window defogger switch	Not pressed	 <small>JPMIA0012GB</small> 1.0 - 1.5 V
					Pressed	0 V
17 (R/G)	Ground	Optical sensor power supply	Output	Ignition switch	OFF, ACC	0 V
					ON	5 V
18 (V)	Ground	Receiver and sensor ground	Input	Ignition switch ON		0 V
19 (BR)	Ground	Remote keyless entry receiver power supply	Output	Ignition switch OFF		 <small>JMKIA3838GB</small>
20 (G/Y)	Ground	Remote keyless entry receiver communication	Input	Waiting		 <small>JMKIA3838GB</small>
				Signal receiving		 <small>JMKIA3841GB</small>
21 (P/L)	Ground	NATS antenna amp.	Input/ Output	During waiting	Ignition switch is pressed while inserting the key into the key slot.	Just after pressing ignition switch. Pointer of tester should move.
22 (W/G)	Ground	Remote keyless entry receiver RSSI	Input	Waiting		0 V
				Signal receiving		 <small>JMKIA3838GB</small>

BCM (BODY CONTROL MODULE)

< ECU DIAGNOSIS INFORMATION >

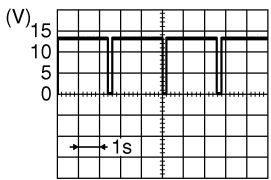
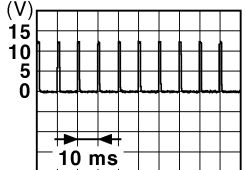
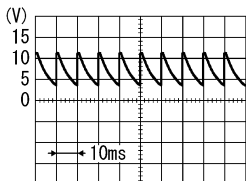
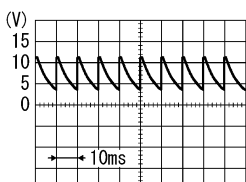
Terminal No. (Wire color)		Description		Condition	Value (Approx.)	
+	-	Signal name	Input/ Output			
23 (R/Y)	Ground	Security indicator lamp	Output	Security indicator	ON	0 V
				Blinking (Ignition switch OFF)	 <p style="text-align: center;">12.0 V</p>	
				OFF	Battery voltage	
24* (GR/R)	Ground	Dongle link	Input/ Output	Ignition switch OFF		5 V
25 (LG)	Ground	NATS antenna amp.	Input/ Output	During waiting	Ignition switch is pressed while inserting the key into the key slot.	Just after pressing ignition switch. Pointer of tester should move.
27 (Y/G)	Ground	A/C switch	Input	Air conditioner	OFF (A/C switch indicator: OFF)	 <p style="text-align: center;">1.0 - 1.5 V</p>
				ON (A/C switch indicator: ON)	0 V	
28 (G/W)	Ground	Blower fan switch	Input	Blower fan	OFF	0 V
				ON	 <p style="text-align: center;">7.0 - 8.0 V</p>	
29 (L/W)	Ground	Hazard switch	Input	Hazard switch	OFF	12 V
				ON	0 V	
31 (G/B)	Ground	Front door lock assembly driver side (Unlock sensor)	Input	Driver door	LOCK status (Unlock sensor switch OFF)	 <p style="text-align: center;">7.0 - 8.0 V</p>
				UNLOCK status (Unlock sensor switch ON)	0 V	

A
B
C
D
E
F
G
H
I
J
K
M
N
O
P

EXL

BCM (BODY CONTROL MODULE)

< ECU DIAGNOSIS INFORMATION >

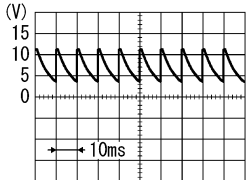
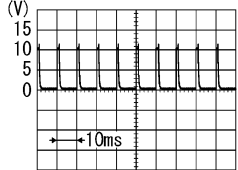
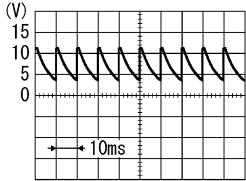
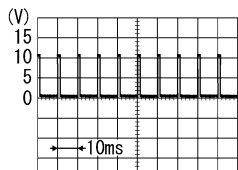
Terminal No. (Wire color)		Description		Condition	Value (Approx.)	
		Signal name	Input/ Output			
+	-					
32 (LG)	Ground	Combination switch OUTPUT 5	Output	Combination switch	All switch OFF (Wiper intermittent dial 4)	 <p style="text-align: right; font-size: small;">PKIB4960J</p> <p style="text-align: center;">7.0 - 8.0 V</p>
					Front fog lamp switch ON (Wiper intermittent dial 4)	 <p style="text-align: right; font-size: small;">PKIB4966J</p> <p style="text-align: center;">1.0 V</p>
					Rear wiper switch ON (Wiper intermittent dial 4)	
Any of the condition below with all switch OFF						
<ul style="list-style-type: none"> Wiper intermittent dial 1 Wiper intermittent dial 2 Wiper intermittent dial 6 Wiper intermittent dial 7 						
33 (Y/L)	Ground	Combination switch OUTPUT 4	Output	Combination switch	All switch OFF (Wiper intermittent dial 4)	 <p style="text-align: right; font-size: small;">PKIB4960J</p> <p style="text-align: center;">7.0 - 8.0 V</p>
					Lighting switch 1ST (Wiper intermittent dial 4)	 <p style="text-align: right; font-size: small;">PKIB4958J</p> <p style="text-align: center;">1.2 V</p>
					Lighting switch AUTO (Wiper intermittent dial 4)	
					Rear wiper switch INT (Wiper intermittent dial 4)	
Any of the condition below with all switch OFF						
<ul style="list-style-type: none"> Wiper intermittent dial 1 Wiper intermittent dial 5 Wiper intermittent dial 6 						

BCM (BODY CONTROL MODULE)

< ECU DIAGNOSIS INFORMATION >

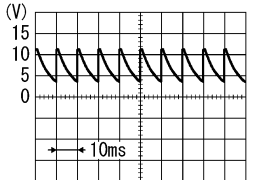
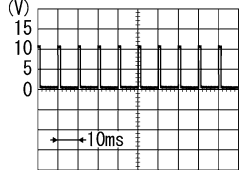
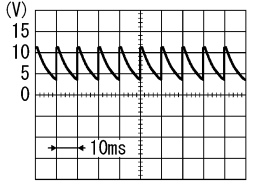
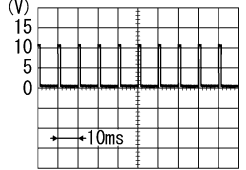
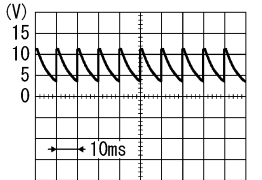
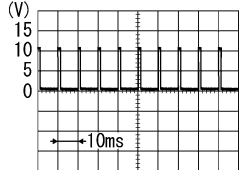
Terminal No. (Wire color)		Description		Condition	Value (Approx.)
+	-	Signal name	Input/ Output		
34 (W)	Ground	Combination switch OUTPUT 3	Output	Combination switch	All switch OFF (Wiper intermittent dial 4)  7.0 - 8.0 V
					Lighting switch 2ND (Wiper intermittent dial 4)  1.2 V
					Lighting switch HI (Wiper intermittent dial 4)
					Rear washer switch ON (Wiper intermittent dial 4)
35 (R/L)	Ground	Combination switch OUTPUT 2	Output	Combination switch (Wiper intermit- tent dial 4)	All switch OFF  7.0 - 8.0 V
					Lighting switch 2ND  1.2 V
					Lighting switch PASS
					Front wiper switch INT
36 (L/O)	Ground	Combination switch OUTPUT 1	Output	Combination switch (Wiper intermit- tent dial 4)	All switch OFF  7.0 - 8.0 V
					Turn signal switch RH  1.2 V
					Turn signal switch LH
					Front wiper switch LO (Front wiper switch MIST)
					Front washer switch ON

A
B
C
D
E
F
G
H
I
J
K
EXL
M
N
O
P

BCM (BODY CONTROL MODULE)

< ECU DIAGNOSIS INFORMATION >

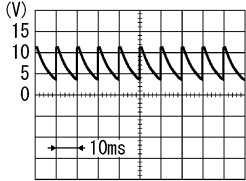
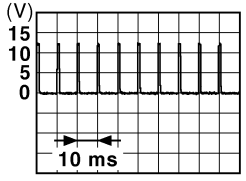
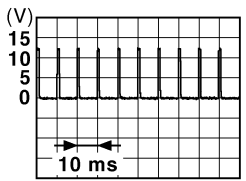
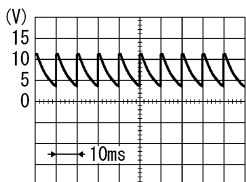
Terminal No. (Wire color)		Description		Condition		Value (Approx.)
		Signal name	Input/ Output			
+	-					
37 (G/O)	Ground	Selector lever P position switch	Input	Selector lever	P position	0 V
					Any position other than P	12 V
38 (O)	Ground	IGN feedback	Input	Ignition switch	OFF or ACC	0 V
					ON	Battery voltage
39 (L)	Ground	CAN-H	Input/ Output		—	—
40 (P)	Ground	CAN-L	Input/ Output		—	—
43 (W)	Ground	Back door switch	Input	Back door switch	OFF (When back door closed)	 <p style="text-align: center;">PKIB4960J 9.5 - 10.0 V</p>
					ON (When back door opened)	0 V
44 (LG)	Ground	Rear wiper stop position	Input	Ignition switch ON	Rear wiper stop position	12 V
					Any position other than rear wiper stop position	0 V
45 (GR)	Ground	Door lock and unlock switch LOCK	Input	Door lock and unlock switch	NEUTRAL position	 <p style="text-align: center;">JPMA0012GB 1.0 - 1.5 V</p>
					LOCK position	0 V
46 (BR)	Ground	Door lock and unlock switch UNLOCK	Input	Door lock and unlock switch	NEUTRAL position	 <p style="text-align: center;">JPMA0012GB 1.0 - 1.5 V</p>
					UNLOCK position	0 V
47 (BR/Y)	Ground	Driver door switch	Input	Driver door switch	OFF (When driver door closed)	 <p style="text-align: center;">PKIB4960J 7.0 - 8.0 V</p>
					ON (When driver door opened)	0 V

BCM (BODY CONTROL MODULE)

< ECU DIAGNOSIS INFORMATION >

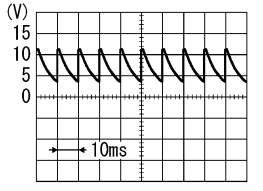
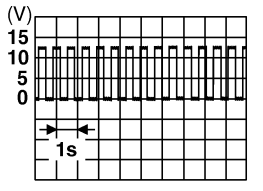
Terminal No. (Wire color)		Description		Condition		Value (Approx.)
+	-	Signal name	Input/ Output			
48 (W/G)	Ground	Rear LH door switch	Input	Rear LH door switch	OFF (When rear LH door closed)	 7.0 - 8.0 V
					ON (When rear door LH opened)	0 V
49 (Y)	Ground	Luggage room lamp	Output	Luggage room lamp switch DOOR position	Back door is closed (Back door lamp turns OFF)	12 V
					Back door is opened (Back door lamp turns ON)	0 V
54 (L/W)	Ground	Rear wiper	Output	Rear wiper	OFF (Stopped)	0 V
					ON (Activated)	12 V
55 (G)	Ground	Rear door UNLOCK	Output	Rear door	UNLOCK (Actuator is activated)	12 V
					Other than UNLOCK (Actuator is not activated)	0 V
56 (L)	Ground	Interior room lamp power supply	Output	Interior room lamp battery saver is activated. (Cuts the interior room lamp power supply)	0 V	
					Interior room lamp battery saver is not activated. (Outputs the interior room lamp power supply)	12 V
57 (Y)	Ground	Battery power supply	Input	Ignition switch OFF	Battery voltage	
59 (G)	Ground	Passenger door UNLOCK	Output	Passenger door	UNLOCK (Actuator is activated)	12 V
					Other than UNLOCK (Actuator is not activated)	0 V
60 (W/B)	Ground	Turn signal LH	Output	Ignition switch ON	Turn signal switch OFF	0 V
					Turn signal switch LH	 6.0 V

A
B
C
D
E
F
G
H
I
J
K
EXL
M
N
O
P

BCM (BODY CONTROL MODULE)

< ECU DIAGNOSIS INFORMATION >

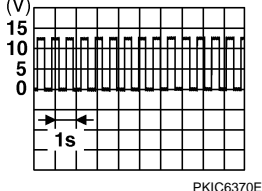
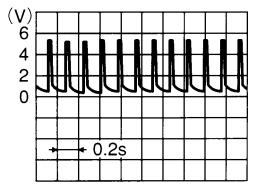
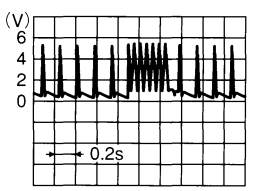
Terminal No. (Wire color)		Description		Condition	Value (Approx.)
+	-	Signal name	Input/ Output		
61 (W/L)	Ground	Turn signal RH	Output	Ignition switch ON	Turn signal switch OFF 0 V
				Turn signal switch RH	 6.0 V
63 (BR)	Ground	Interior room lamp timer control	Output	Interior room lamp	OFF 12 V
				ON	0 V
65 (V)	Ground	All doors LOCK	Output	All doors	LOCK (Actuator is activat- ed) 12 V
				Other then LOCK (Actua- tor is not activated)	0 V
66 (L/B)	Ground	Driver door UN- LOCK	Output	Driver door	UNLOCK (Actuator is activat- ed) 12 V
				Other then UNLOCK (Ac- tuator is not activated)	0 V
67 (B)	Ground	Ground	Output	Ignition switch ON	0 V
68 (L)	Ground	P/W power supply (IGN)	Output	Ignition switch ON	12 V
69 (L/W)	Ground	P/W power supply (BAT)	Output	Ignition switch OFF	12 V
70 (Y)	Ground	Battery power sup- ply	Input	Ignition switch OFF	Battery voltage
71 (R)	Ground	Tire pressure receiv- er communication	Input/ Output	Ignition switch ON	Standby state 
				When receiving the signal from the transmitter	
72 (R/W)	Ground	Back door lock actu- ator relay control	Output	Back door	LOCK (Actuator is activat- ed) 0 V
				Other than LOCK (Actua- tor is not activated)	Battery voltage
75 (SB)	Ground	Driver door request switch	Input	Driver door re- quest switch	ON (Pressed) 0 V
				OFF (Not pressed)	12 V

BCM (BODY CONTROL MODULE)

< ECU DIAGNOSIS INFORMATION >

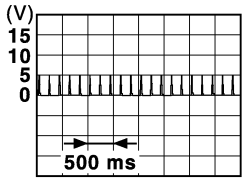
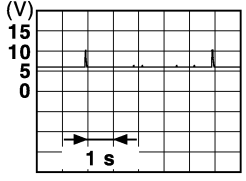
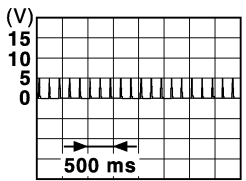
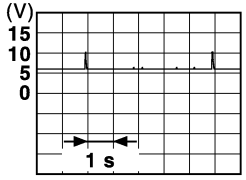
Terminal No. (Wire color)		Description		Condition		Value (Approx.)
+	-	Signal name	Input/ Output			
76 (G)	Ground	Passenger door re- quest switch	Input	Passenger door re- quest switch	ON (Pressed)	0 V
					OFF (Not pressed)	12 V
77 (W)	Ground	Back door request switch	Input	Back door re- quest switch	ON (Pressed)	0 V
					OFF (Not pressed)	12 V
78 (LG)	Ground	Driver door antenna (+)	Output	When the driver door request switch is operat- ed with ignition switch OFF	When Intelligent Key is not in the antenna detec- tion area	 <small>JMKIA3838GB</small>
					When Intelligent Key is in the antenna detection area	 <small>JMKIA3839GB</small>
79 (V)	Ground	Driver door antenna (-)	Output	When the driver door request switch is operat- ed with ignition switch OFF	When Intelligent Key is not in the antenna detec- tion area	 <small>JMKIA3838GB</small>
					When Intelligent Key is in the antenna detection area	 <small>JMKIA3839GB</small>

A
B
C
D
E
F
G
H
I
J
K
L
M
N
O
P

EXL

BCM (BODY CONTROL MODULE)

< ECU DIAGNOSIS INFORMATION >

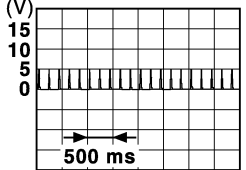
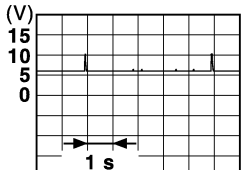
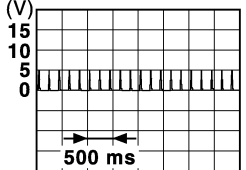
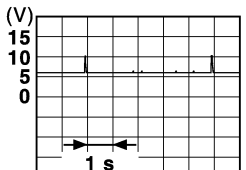
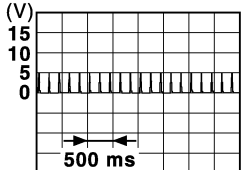
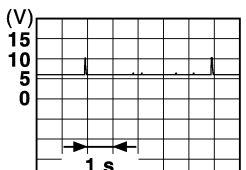
Terminal No. (Wire color)		Description		Condition	Value (Approx.)
+	-	Signal name	Input/ Output		
80 (BR/Y)	Ground	Passenger door antenna (+)	Output	When the Intelligent Key is not in the antenna detection area	 <p style="text-align: right; font-size: small;">JMkia3838GB</p>
				When the passenger door request switch is operated with ignition switch OFF	 <p style="text-align: right; font-size: small;">JMkia3839GB</p>
81 (L/Y)	Ground	Passenger door antenna (-)	Output	When the Intelligent Key is not in the antenna detection area	 <p style="text-align: right; font-size: small;">JMkia3838GB</p>
				When the passenger door request switch is operated with ignition switch OFF	 <p style="text-align: right; font-size: small;">JMkia3839GB</p>
82 (W/B)	Ground	Back door antenna (+)	Output	When the Intelligent Key is not in the antenna detection area	 <p style="text-align: right; font-size: small;">JMkia3838GB</p>
				When the back door request switch is operated with ignition switch OFF	 <p style="text-align: right; font-size: small;">JMkia3839GB</p>

BCM (BODY CONTROL MODULE)

< ECU DIAGNOSIS INFORMATION >

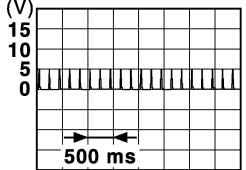
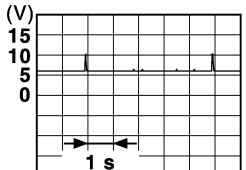
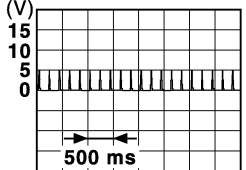
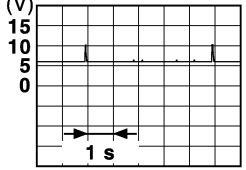
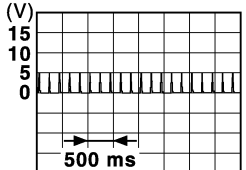
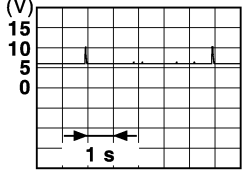
Terminal No. (Wire color)		Description		Condition	Value (Approx.)
		Signal name	Input/ Output		
+	-				
83 (B/W)	Ground	Back door antenna (-)	Output	When the back door request switch is operated with ignition switch OFF	 <p style="text-align: right; font-size: small;">JMkia3838GB</p>
				When Intelligent Key is in the antenna detection area	 <p style="text-align: right; font-size: small;">JMkia3839GB</p>
84 (Y/G)	Ground	Room antenna (+) (Instrument panel)	Output	Ignition switch OFF	 <p style="text-align: right; font-size: small;">JMkia3838GB</p>
				When Intelligent Key is in the antenna detection area	 <p style="text-align: right; font-size: small;">JMkia3839GB</p>
85 (Y/L)	Ground	Room antenna (-) (Instrument panel)	Output	Ignition switch OFF	 <p style="text-align: right; font-size: small;">JMkia3838GB</p>
				When Intelligent Key is in the antenna detection area	 <p style="text-align: right; font-size: small;">JMkia3839GB</p>

A
B
C
D
E
F
G
H
I
J
K
M
N
O
P

EXL

BCM (BODY CONTROL MODULE)

< ECU DIAGNOSIS INFORMATION >

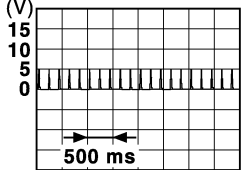
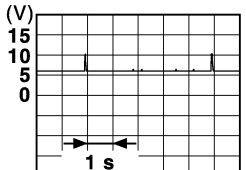
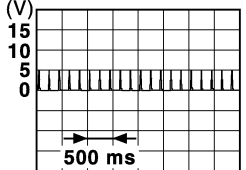
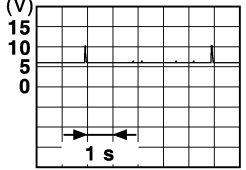
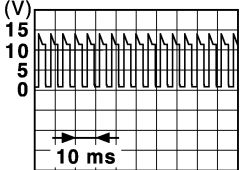
Terminal No. (Wire color)		Description		Condition	Value (Approx.)				
+	-	Signal name	Input/ Output						
86 (P)	Ground	Luggage room antenna (+)	Output	Ignition switch OFF	 <p style="text-align: right; font-size: small;">JMkia3838GB</p>				
				When Intelligent Key is in the antenna detection area	 <p style="text-align: right; font-size: small;">JMkia3839GB</p>				
87 (L)	Ground	Luggage room antenna (-)	Output	Ignition switch OFF	 <p style="text-align: right; font-size: small;">JMkia3838GB</p>				
				When Intelligent Key is in the antenna detection area	 <p style="text-align: right; font-size: small;">JMkia3839GB</p>				
90 (W/L)	Ground	Push-button ignition switch illumination	Output	Push-button ignition switch illumination	<table border="0" style="width: 100%;"> <tr> <td style="width: 50%;">ON</td> <td style="text-align: right;">12 V</td> </tr> <tr> <td>OFF</td> <td style="text-align: right;">0 V</td> </tr> </table>	ON	12 V	OFF	0 V
ON	12 V								
OFF	0 V								
91 (Y)	Ground	ACC/ON indicator lamp	Output	Ignition switch	Battery voltage				
				ACC or ON	0.5 V				
92 (BR/R)	Ground	Push-button ignition switch illumination ground	Output	Tail lamp	0 V				
				ON	<p>NOTE: When the illumination brightening/dimming level is in the neutral position</p>  <p style="text-align: right; font-size: small;">JPMIA1554GB</p> <p style="text-align: center;">6.0 - 7.0 V</p>				

BCM (BODY CONTROL MODULE)

< ECU DIAGNOSIS INFORMATION >

Terminal No. (Wire color)		Description		Condition	Value (Approx.)	
		Signal name	Input/ Output			
+	-					
93 (GR/W)	Ground	Intelligent Key warn- ing buzzer	Output	Intelligent Key warning buzzer	Sounding	0 V
					Not sounding	12 V
94 (Y/R)	Ground	Steering lock unit communication	Input/ Output	Steering lock	LOCK status	12 V
					LOCK or UNLOCK	
					For 15 seconds after UN- LOCK	
					15 seconds or later after UNLOCK	0 V
95 (W/G)	Ground	Steering lock unit power supply	Output	Ignition switch	OFF or ACC	12 V
					ON	0 V
96 (BR/W)	Ground	ACC relay control	Output	Ignition switch	OFF	0 V
					ACC or ON	12 V
97 (L/R)	Ground	Starter relay control	Output	Ignition switch ON	When selector lever is in P or N position	Battery voltage
					When selector lever is not in P or N position	0 V
98 (BR)	Ground	Ignition relay (IPDM E/R) control	Output	Ignition switch	OFF or ACC	12 V
					ON	0 V
99 (W/R)	Ground	Ignition relay control	Output	Ignition switch	OFF or ACC	0 V
					ON	12 V
100 (L/O)	Ground	Push-button ignition switch (push switch)	Input	Push-button ig- nition switch (push switch)	Pressed	0 V
					Not pressed	12 V
102 (G)	Ground	Selector lever P/N position	Input	Selector lever	P or N position	Battery voltage
					Except P and N positions	0 V
104 (Y/R)	Ground	CVT shift selector (detention switch) power supply	Output	Ignition switch ON	12 V	
105 (B/O)	Ground	Stop lamp switch 2	Input	Ignition switch OFF	Battery voltage	
106 (Y/B)	Ground	Blower fan motor re- lay control	Output	Ignition switch	OFF or ACC	0 V
					ON	12 V
107 (L/W)	Ground	Steering lock condi- tion No. 1	Input	Steering lock	LOCK status	0 V
					UNLOCK status	12 V
108 (P/L)	Ground	Steering lock condi- tion No. 2	Input	Steering lock	LOCK status	12 V
					UNLOCK status	0 V
110 (BR/W)	Ground	Tire pressure receiv- er power supply	Output	Ignition switch	OFF or ACC	0 V
					ON	5 V

*: For Canada

A
B
C
D
E
F
G
H
I
J
K
EXL
M
N
O
P

BCM (BODY CONTROL MODULE)

< ECU DIAGNOSIS INFORMATION >

WITH INTELLIGENT KEY : Wiring Diagram - BCM -

INFOID:000000005185902

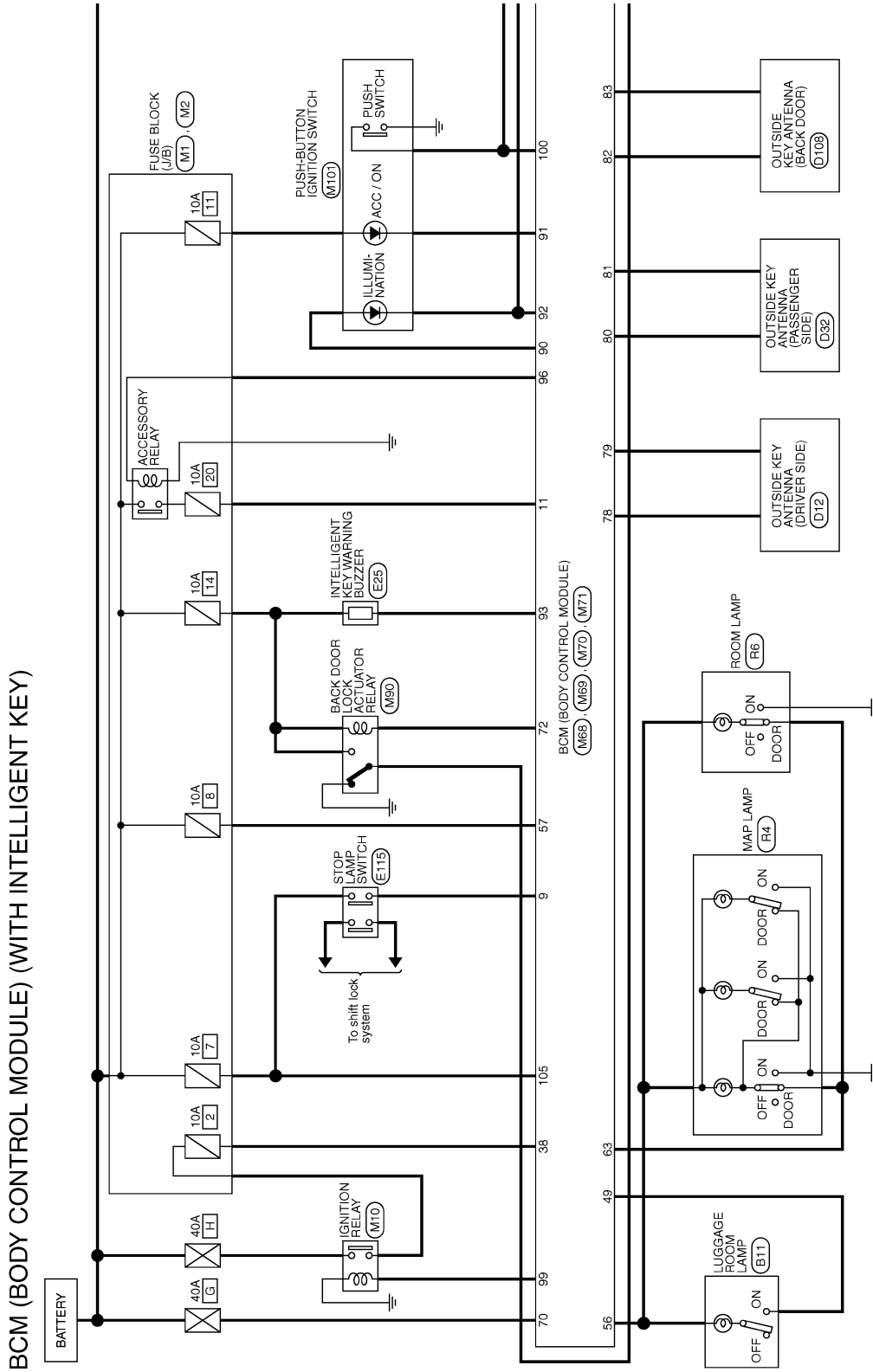

BCM (BODY CONTROL MODULE) (WITH INTELLIGENT KEY)

JCMWM4068GB

2009/02/27

BCM (BODY CONTROL MODULE)

< ECU DIAGNOSIS INFORMATION >

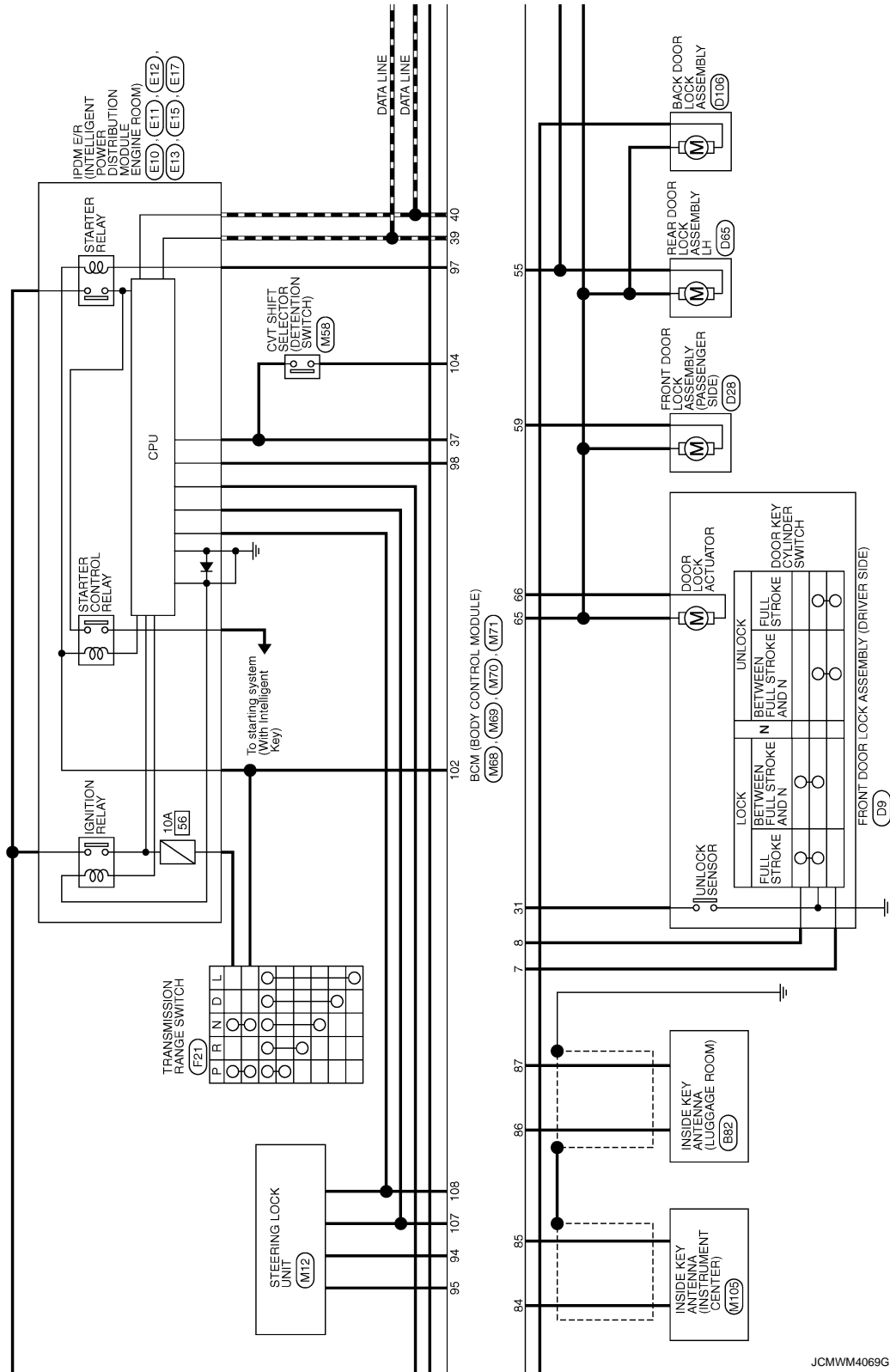

JCMWM4069GB

A
B
C
D
E
F
G
H
I
J
K
L
M
N
O
P

EXL

BCM (BODY CONTROL MODULE)

< ECU DIAGNOSIS INFORMATION >

 : For Canada

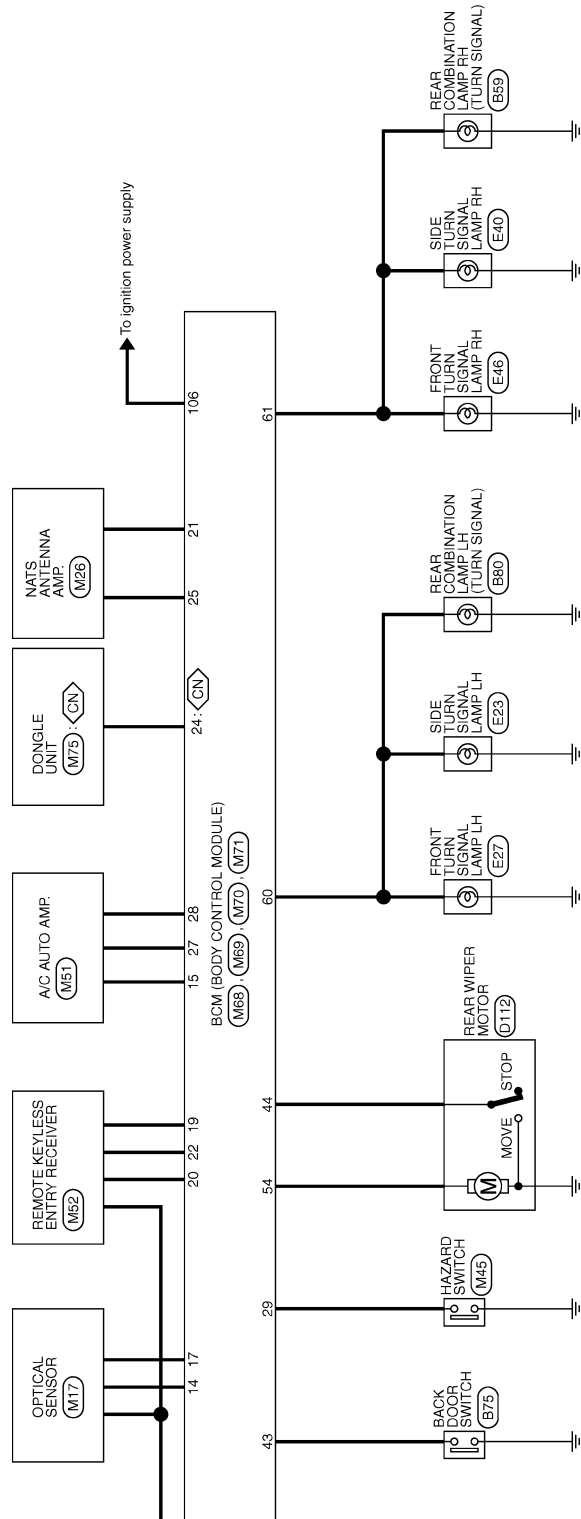

JCMWM4071GB

A
B
C
D
E
F
G
H
I
J
K
EXL
M
N
O
P

BCM (BODY CONTROL MODULE)

< ECU DIAGNOSIS INFORMATION >

BCM (BODY CONTROL MODULE) (WITH INTELLIGENT KEY)

Connector No.	M27
Connector Name	COMBINATION SWITCH
Connector Type	TH16FW-NH

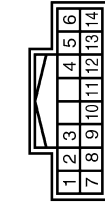

Terminal No.	Color of Wire	Signal Name [Specification]
2	GR	INPUT 4
5	L/Y	INPUT 3
7	W	OUTPUT 3
8	BR/W	INPUT 5
9	R/L	OUTPUT 2
10	Y/L	OUTPUT 4
11	L/O	OUTPUT 1
12	L/R	INPUT 1
13	LG	OUTPUT 5
14	G	INPUT 2

Connector No.	M70
Connector Name	BCM (BODY CONTROL MODULE) (WITH INTELLIGENT KEY)
Connector Type	FEA09FB-FHA6-SA



Terminal No.	Color of Wire	Signal Name [Specification]
56	L	INTERIOR ROOM LAMP POWER SUPPLY
57	Y	BAT (FUSE)
59	G	PASSENGER DOOR UNLOCK OUTPUT
60	W/B	TURN SIGNAL LH OUTPUT
61	W/L	TURN SIGNAL RH OUTPUT
63	BR	ROOM LAMP TIMER CONTROL
65	V	ALL DOOR LOCK OUTPUT
66	L/B	DRIVER DOOR UNLOCK OUTPUT
67	B	GND
68	L	POWER WINDOW POWER SUPPLY (GN)
69	L/W	POWER WINDOW POWER SUPPLY (BAT)

Connector No.	M66
Connector Name	BCM (BODY CONTROL MODULE) (WITH INTELLIGENT KEY)
Connector Type	TH40FB-NH

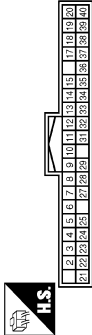

Terminal No.	Color of Wire	Signal Name [Specification]
2	BR/W	COMBI SW INPUT 5
3	GR	COMBI SW INPUT 4
4	L/Y	COMBI SW INPUT 3
5	G	COMBI SW INPUT 2
6	L/R	COMBI SW INPUT 1
7	W/B	KEY CYL UNLOCK SW
8	W/B	KEY CYL LOCK SW
9	R	STOP LAMP SW 1
10	V/W	TIRE PRESS WARNING CHECK SW
11	L/Y	ACC F/B
12	SB	PASSENGER DOOR SW

Connector No.	M71
Connector Name	BCM (BODY CONTROL MODULE) (WITH INTELLIGENT KEY)
Connector Type	TH40FW-NH



Terminal No.	Color of Wire	Signal Name [Specification]
71	R	TIRE PRESS RECEIVER COMM
72	R/W	BK DR LOCK ACT RELAY CONT
75	SB	DRIVER DOOR REQUEST SW
76	G	PASSENGER DOOR REQUEST SW
77	W	BACK DOOR REQUEST SW
78	LG	DRIVER DOOR ANT+
79	V	DRIVER DOOR ANT-
80	BR/Y	PASSENGER DOOR ANT+
81	L/Y	PASSENGER DOOR ANT-
82	W/B	BACK DOOR ANT+
83	B/W	BACK DOOR ANT-

Terminal No.	Color of Wire	Signal Name [Specification]
13	GR/L	REAR RH DOOR SW
14	L/B	OPTICAL SENSOR
15	W/L	REAR WINDOW DEFROGER SW
17	R/G	OPTICAL SENSOR POWER SUPPLY
18	V	RECEIVER SENSOR GND
19	BR	KEYLESS ENTRY RECEIVER POWER SUPPLY
20	G/Y	KEYLESS ENTRY RECEIVER COMM
21	P/L	NATS ANTENNA AMP-
22	W/G	KEYLESS ENTRY RECEIVER RSSI
23	R/Y	SECURITY INDICATOR LAMP
24	GR/R	DOUBLE LINK
25	LG	NATS ANTENNA AMP-
27	Y/G	A/C SW
28	G/W	BLOWER FAN SW
29	L/W	HAZARD SW
31	G/B	DR DOOR UNLOCK SENSOR
32	LG	COMBI SW OUTPUT 5
33	Y/L	COMBI SW OUTPUT 4
34	W	COMBI SW OUTPUT 3
35	R/L	COMBI SW OUTPUT 2
36	L/O	COMBI SW OUTPUT 1
37	L/O	SHIFT P
38	O	IGN F/B
39	L	CAN-H
40	P	CAN-L

Connector No.	M71
Connector Name	BCM (BODY CONTROL MODULE) (WITH INTELLIGENT KEY)
Connector Type	TH40FW-NH

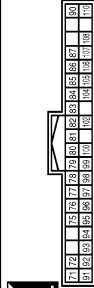

Connector No.	M69
Connector Name	BCM (BODY CONTROL MODULE) (WITH INTELLIGENT KEY)
Connector Type	FEA09FW-FHA6-SA

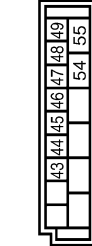

Terminal No.	Color of Wire	Signal Name [Specification]
43	W	BACK DOOR SW
44	LG	REAR WIPER STOP POSITION
45	GR	CENTRAL DOOR LOCK SW
46	BR	CENTRAL DOOR UNLOCK SW
47	BR/Y	DRIVER DOOR SW
48	W/G	REAR LH DOOR SW
49	V	LUGGAGE ROOM LAMP OUTPUT
54	L/W	REAR WIPER OUTPUT
55	G	REAR DOOR UNLOCK OUTPUT

Terminal No.	Color of Wire	Signal Name [Specification]
84	Y/G	ROOM ANT-
85	Y/L	ROOM ANT-
86	P	LUGGAGE ROOM ANT-
87	L	LUGGAGE ROOM ANT-
90	W/L	PUSH-BUTTON IGNITION SW ILL POWER
91	Y	ACC/ON IND
92	BR/R	PUSH-BUTTON IGNITION SW ILL GND
93	GR/W	F-KEY WARN BUZZER
94	Y/B	S/L UNIT COMM
95	W/G	S/L UNIT POWER SUPPLY
96	BR/W	ACC RELAY CONT
97	L/R	STARTER RELAY CONT
98	BR	IGN RELAY (UPDM E/F) CONT
99	W/R	IGN RELAY CONT
100	L/O	PUSH SW
102	G	SHIFT N/P
104	Y/R	CVT SHIFT SELECTOR POWER SUPPLY
105	B/O	STOP LAMP SW 2
106	Y/B	BLOWER FAN MOTOR RELAY CONT
107	L/W	S/L CONDITION 1
108	P/L	S/L CONDITION 2
110	BR/W	TIRE PRESS POWER SUPPLY

WITH INTELLIGENT KEY : Fail-safe

FAIL-SAFE CONTROL BY DTC

BCM performs fail-safe control when any DTC are detected.

JCMWM4072GB

INFOID:000000005185903

BCM (BODY CONTROL MODULE)

< ECU DIAGNOSIS INFORMATION >

Display contents of CONSULT	Fail-safe	Cancellation	
B2013: ID DISCORD BCM-S/L	Inhibit engine cranking	When communication between BCM and steering lock unit are communicated normally.	A
B2014: CHAIN OF S/L-BCM	Inhibit engine cranking	When communication between BCM and steering lock unit are communicated normally.	B
B2192: ID DISCORD BCM-ECM	Inhibit engine cranking	Erase DTC	
B2193: CHAIN OF BCM-ECM	Inhibit engine cranking	Erase DTC	C
B2195: ANTI-SCANNING	Inhibit engine cranking	Ignition switch ON → OFF	
B2196: DONGLE NG	Inhibit engine cranking	Erase DTC	D
B2198: NATS ANTENNA AMP	Inhibit engine cranking	Erase DTC	
B2557: VEHICLE SPEED	Inhibit steering lock	When the following CAN signal status (vehicle speed signal) becomes consistent <ul style="list-style-type: none"> • Vehicle speed signal (ABS) • Vehicle speed signal (Meter) 	E
B2601: SHIFT POSITION	Inhibit steering lock	500 ms after the following signal reception status becomes consistent <ul style="list-style-type: none"> • Selector lever P position switch signal • P range signal (CAN) 	F
B2602: SHIFT POSITION	Inhibit steering lock	5 seconds after the following BCM recognition conditions are fulfilled <ul style="list-style-type: none"> • Ignition switch is in the ON position • Selector lever P position switch signal: Except P position (battery voltage) • Vehicle speed: 4 km/h (2.5 MPH) or more 	G
B2603: SHIFT POSI STATUS	Inhibit steering lock	500 ms after any of the following BCM recognition conditions are fulfilled <ul style="list-style-type: none"> • Status 1 <ul style="list-style-type: none"> - Ignition switch is in the ON position - Selector lever P position switch signal: Except P position (12 V) - Selector lever P/N position signal: Except P and N positions (0 V) • Status 2 <ul style="list-style-type: none"> - Ignition switch is in the ON position - Selector lever P position switch signal: P position (0 V) - Selector lever P/N position signal: P or N positions (12 V) 	H
B2604: PNP/CLUTCH SW	Inhibit steering lock	500 ms after any of the following BCM recognition conditions are fulfilled <ul style="list-style-type: none"> • Status 1 <ul style="list-style-type: none"> - Ignition switch is in the ON position - Selector lever P/N position signal: P or N position (12 V) - Shift position signal (CAN): P or N position • Status 2 <ul style="list-style-type: none"> - Ignition switch is in the ON position - Selector lever P/N position signal: Except P and N positions (0 V) - Shift position signal (CAN): Except P and N position 	I
B2605: PNP/CLUTCH SW	Inhibit steering lock	500 ms after any of the following BCM recognition conditions are fulfilled <ul style="list-style-type: none"> • Status 1 <ul style="list-style-type: none"> - Power position: IGN - Selector lever P/N position signal: Except P and N positions (0 V) - Interlock/PNP switch signal (CAN): OFF • Status 2 <ul style="list-style-type: none"> - Ignition switch is in the ON position - Selector lever P/N position signal: P or N position (12 V) - Interlock/PNP switch signal (CAN): ON 	J
B2608: STARTER RELAY	Inhibit engine cranking	500 ms after the following signal communication status becomes consistent <ul style="list-style-type: none"> • Starter motor relay control signal • Starter relay status signal (CAN) 	K
B2609: S/L STATUS	<ul style="list-style-type: none"> • Inhibit engine cranking • Inhibit steering lock 	When the following steering lock conditions agree <ul style="list-style-type: none"> • BCM steering lock control status • Steering lock condition No. 1 signal status • Steering lock condition No. 2 signal status 	EXL
B260B: STEERING LOCK UNIT	Inhibit steering lock	Erase DTC	M
			N
			O
			P

BCM (BODY CONTROL MODULE)

< ECU DIAGNOSIS INFORMATION >

Display contents of CONSULT	Fail-safe	Cancellation
B260D: STEERING LOCK UNIT	Inhibit steering lock	Erase DTC
B260F: ENG STATE SIG LOST	Inhibit engine cranking	When any of the following conditions are fulfilled <ul style="list-style-type: none"> • Power position changes to ACC • Receives engine status signal (CAN)
B2612: S/L STATUS	<ul style="list-style-type: none"> • Inhibit engine cranking • Inhibit steering lock 	When any of the following conditions are fulfilled <ul style="list-style-type: none"> • Steering lock unit status signal (CAN) is received normally • The BCM steering lock control status matches the steering lock status recognized by the steering lock unit status signal (CAN from IPDM E/R)
B2619: BCM	Inhibit engine cranking	1 second after the steering lock unit power supply output control inside BCM becomes normal
B26EF: STRG LCK RELAY OFF	Inhibit engine cranking	When the following conditions are fulfilled <ul style="list-style-type: none"> • Steering lock relay signal (CAN): ON • Steering lock unit status signal (CAN): ON
B26F0: STRG LCK RELAY ON	Inhibit engine cranking	When the following conditions are fulfilled <ul style="list-style-type: none"> • Steering lock relay signal (CAN): OFF • Steering lock unit status signal (CAN): OFF
B26F1: IGN RELAY OFF	Inhibit engine cranking	When the following conditions are fulfilled <ul style="list-style-type: none"> • Ignition switch ON signal (CAN: Transmitted from BCM): ON • Ignition switch ON signal (CAN: Transmitted from IPDM E/R): ON
B26F2: IGN RELAY ON	Inhibit engine cranking	When the following conditions are fulfilled <ul style="list-style-type: none"> • Ignition switch ON signal (CAN: Transmitted from BCM): OFF • Ignition switch ON signal (CAN: Transmitted from IPDM E/R): OFF
B26F3: START CONT RLY ON	Inhibit engine cranking	When the following conditions are fulfilled <ul style="list-style-type: none"> • Starter control relay signal (CAN: Transmitted from BCM): OFF • Starter control relay signal (CAN: Transmitted from IPDM E/R): OFF
B26F4: START CONT RLY OFF	Inhibit engine cranking	When the following conditions are fulfilled <ul style="list-style-type: none"> • Starter control relay signal (CAN: Transmitted from BCM): ON • Starter control relay signal (CAN: Transmitted from IPDM E/R): ON
B26F7: BCM	Inhibit engine cranking by Intelligent Key system	When room antenna and luggage room antenna functions normally
U0415: VEHICLE SPEED	Inhibit steering lock	When vehicle speed signal (Meter) (CAN) is received normally

HIGH FLASHER OPERATION

BCM detects the turn signal lamp circuit status by the current value.

BCM increases the turn signal lamp blinking speed if the bulb or harness open is detected with the turn signal lamp operating.

NOTE:

The blinking speed is normal while activating the hazard warning lamp.

REAR WIPER MOTOR PROTECTION

BCM detects the rear wiper stopping position according to the rear wiper stop position signal.

When the rear wiper stop position signal does not change for more than 5 seconds while driving the rear wiper, BCM stops power supply to protect the rear wiper motor.

Condition of cancellation

1. More than 1 minute is passed after the rear wiper stop.
2. Turn rear wiper switch OFF.
3. Operate the rear wiper switch or rear washer switch.

WITH INTELLIGENT KEY : DTC Inspection Priority Chart

INFOID:000000005185904

If some DTCs are displayed at the same time, perform inspections one by one based on the following priority chart.

BCM (BODY CONTROL MODULE)

< ECU DIAGNOSIS INFORMATION >

Priority	DTC	A
1	B2562: LOW VOLTAGE	A
2	<ul style="list-style-type: none"> • U1000: CAN COMM CIRCUIT • U1010: CONTROL UNIT (CAN) 	B
3	<ul style="list-style-type: none"> • B2192: ID DISCORD BCM-ECM • B2193: CHAIN OF BCM-ECM • B2195: ANTI-SCANNING • B2196: DONGLE NG • B2198: NATS ANTENNA AMP 	C
4	<ul style="list-style-type: none"> • B2013: ID DISCORD BCM-S/L • B2014: CHAIN OF S/L-BCM • B2553: IGNITION RELAY • B2555: STOP LAMP • B2556: PUSH-BTN IGN SW • B2557: VEHICLE SPEED • B2601: SHIFT POSITION • B2602: SHIFT POSITION • B2603: SHIFT POSI STATUS • B2604: PNP/CLUTCH SW • B2605: PNP/CLUTCH SW • B2608: STARTER RELAY • B2609: S/L STATUS • B260B: STEERING LOCK UNIT • B260C: STEERING LOCK UNIT • B260D: STEERING LOCK UNIT • B260F: ENG STATE SIG LOST • B2612: S/L STATUS • B2614: BCM • B2615: BCM • B2616: BCM • B2618: BCM • B2619: BCM • B261A: PUSH-BTN IGN SW • B26E9: LOCK MALFUNCTION • B26EF: STRG LCK RELAY OFF • B26F0: STRG LCK RELAY ON • B26F1: IGN RELAY OFF • B26F2: IGN RELAY ON • B26F3: START CONT RLY ON • B26F4: START CONT RLY OFF • B26F5: STRG LCK STS SW • B26F6: BCM • B26F7: BCM • B26F8: BCM • B26FC: KEY REGISTRATION • C1729: VHCL SPEED SIG ERR • U0415: VEHICLE SPEED 	D E F G H I J K EXL M

BCM (BODY CONTROL MODULE)

< ECU DIAGNOSIS INFORMATION >

Priority	DTC
5	<ul style="list-style-type: none"> • C1704: LOW PRESSURE FL • C1705: LOW PRESSURE FR • C1706: LOW PRESSURE RR • C1707: LOW PRESSURE RL • C1708: [NO DATA] FL • C1709: [NO DATA] FR • C1710: [NO DATA] RR • C1711: [NO DATA] RL • C1712: [CHECKSUM ERR] FL • C1713: [CHECKSUM ERR] FR • C1714: [CHECKSUM ERR] RR • C1715: [CHECKSUM ERR] RL • C1716: [PRESSDATA ERR] FL • C1717: [PRESSDATA ERR] FR • C1718: [PRESSDATA ERR] RR • C1719: [PRESSDATA ERR] RL • C1720: [CODE ERR] FL • C1721: [CODE ERR] FR • C1722: [CODE ERR] RR • C1723: [CODE ERR] RL • C1724: [BATT VOLT LOW] FL • C1725: [BATT VOLT LOW] FR • C1726: [BATT VOLT LOW] RR • C1727: [BATT VOLT LOW] RL • C1734: CONTROL UNIT
6	<ul style="list-style-type: none"> • B2621: INSIDE ANTENNA • B2622: INSIDE ANTENNA
7	<ul style="list-style-type: none"> • B2626: OUTSIDE ANTENNA • B2627: OUTSIDE ANTENNA • B2628: OUTSIDE ANTENNA

WITH INTELLIGENT KEY : DTC Index

INFOID:000000005185905

NOTE:

The details of time display are as follows.

- CRNT: A malfunction is detected now.
- PAST: A malfunction was detected in the past.

IGN counter is displayed on Freeze Frame Data. For details of Freeze Frame Data, refer to [BCS-18, "COMMON ITEM : CONSULT-III Function \(BCM - COMMON ITEM\)"](#).

CONSULT display	Fail-safe	Freeze Frame Data •Vehicle Speed •Odo/Trip Meter •Vehicle Condition	Intelligent Key warning lamp ON	Tire pressure monitor warning lamp ON	Reference page
No DTC is detected. further testing may be required.	—	—	—	—	—
U1000: CAN COMM	—	—	—	—	BCS-39
U1010: CONTROL UNIT (CAN)	—	—	—	—	BCS-40
U0415: VEHICLE SPEED	×	—	×	—	BCS-41
B2013: ID DISCORD BCM-S/L	×	×	×	—	SEC-45
B2014: CHAIN OF S/L-BCM	×	×	×	—	SEC-46
B2192: ID DISCORD BCM-ECM	×	—	—	—	SEC-35
B2193: CHAIN OF BCM-ECM	×	—	—	—	SEC-37
B2195: ANTI-SCANNING	×	—	—	—	SEC-38
B2196: DONGLE NG	×	—	—	—	SEC-39

BCM (BODY CONTROL MODULE)

< ECU DIAGNOSIS INFORMATION >

CONSULT display	Fail-safe	Freeze Frame Data •Vehicle Speed •Odo/Trip Meter •Vehicle Condition	Intelligent Key warning lamp ON	Tire pressure monitor warning lamp ON	Reference page
B2198: NATS ANTENNA AMP	×	—	—	—	SEC-41
B2553: IGNITION RELAY	—	×	×	—	PCS-78
B2555: STOP LAMP	—	×	×	—	SEC-49
B2556: PUSH-BTN IGN SW	—	×	×	—	SEC-51
B2557: VEHICLE SPEED	×	×	×	—	SEC-53
B2562: LOW VOLTAGE	—	×	—	—	BCS-42
B2601: SHIFT POSITION	×	×	×	—	SEC-54
B2602: SHIFT POSITION	×	×	×	—	SEC-57
B2603: SHIFT POSI STATUS	×	×	×	—	SEC-60
B2604: PNP/CLUTCH SW	×	×	×	—	SEC-65
B2605: PNP/CLUTCH SW	×	×	×	—	SEC-68
B2608: STARTER RELAY	×	×	×	—	SEC-70
B2609: S/L STATUS	×	×	×	—	SEC-72
B260B: STEERING LOCK UNIT	×	×	×	—	SEC-75
B260C: STEERING LOCK UNIT	—	×	×	—	SEC-76
B260D: STEERING LOCK UNIT	×	×	×	—	SEC-77
B260F: ENG STATE SIG LOST	×	×	×	—	SEC-78
B2612: S/L STATUS	×	×	×	—	SEC-79
B2614: BCM	—	×	×	—	PCS-80
B2615: BCM	—	×	×	—	PCS-83
B2616: BCM	—	×	×	—	PCS-86
B2618: BCM	—	×	×	—	PCS-89
B2619: BCM	×	×	×	—	SEC-82
B261A: PUSH-BTN IGN SW	—	×	×	—	PCS-90
B2621: INSIDE ANTENNA	—	×	—	—	DLK-44
B2622: INSIDE ANTENNA	—	×	—	—	DLK-46
B2626: OUTSIDE ANTENNA	—	×	—	—	DLK-48
B2627: OUTSIDE ANTENNA	—	×	—	—	DLK-50
B2628: OUTSIDE ANTENNA	—	×	—	—	DLK-52
B26E9: LOCK MALFUNCTION	—	×	× (Turn ON for 15 seconds)	—	SEC-83
B26EF: STRG LCK RELAY OFF	×	×	×	—	SEC-84
B26F0: STRG LCK RELAY ON	×	×	×	—	SEC-86
B26F1: IGN RELAY OFF	×	×	×	—	PCS-92
B26F2: IGN RELAY ON	×	×	×	—	PCS-95
B26F3: START CONT RLY ON	×	×	×	—	SEC-87
B26F4: START CONT RLY OFF	×	×	×	—	SEC-88
B26F5: STRG LCK STS SW	—	×	×	—	SEC-90
B26F6: BCM	—	×	×	—	PCS-98
B26F7: BCM	×	×	×	—	SEC-93
B26F8: BCM	—	×	×	—	SEC-94

A
B
C
D
E
F
G
H
I
J
K
EXL
M
N
O
P

BCM (BODY CONTROL MODULE)

< ECU DIAGNOSIS INFORMATION >

CONSULT display	Fail-safe	Freeze Frame Data •Vehicle Speed •Odo/Trip Meter •Vehicle Condition	Intelligent Key warning lamp ON	Tire pressure monitor warning lamp ON	Reference page
B26FC: KEY REGISTRATION	—	×	×	—	SEC-95
C1704: LOW PRESSURE FL	—	—	—	×	WT-16
C1705: LOW PRESSURE FR	—	—	—	×	
C1706: LOW PRESSURE RR	—	—	—	×	
C1707: LOW PRESSURE RL	—	—	—	×	
C1708: [NO DATA] FL	—	—	—	×	WT-18
C1709: [NO DATA] FR	—	—	—	×	
C1710: [NO DATA] RR	—	—	—	×	
C1711: [NO DATA] RL	—	—	—	×	
C1712: [CHECKSUM ERR] FL	—	—	—	×	WT-21
C1713: [CHECKSUM ERR] FR	—	—	—	×	
C1714: [CHECKSUM ERR] RR	—	—	—	×	
C1715: [CHECKSUM ERR] RL	—	—	—	×	
C1716: [PRESSDATA ERR] FL	—	—	—	×	WT-24
C1717: [PRESSDATA ERR] FR	—	—	—	×	
C1718: [PRESSDATA ERR] RR	—	—	—	×	
C1719: [PRESSDATA ERR] RL	—	—	—	×	
C1720: [CODE ERR] FL	—	—	—	×	WT-26
C1721: [CODE ERR] FR	—	—	—	×	
C1722: [CODE ERR] RR	—	—	—	×	
C1723: [CODE ERR] RL	—	—	—	×	
C1724: [BATT VOLT LOW] FL	—	—	—	×	WT-29
C1725: [BATT VOLT LOW] FR	—	—	—	×	
C1726: [BATT VOLT LOW] RR	—	—	—	×	
C1727: [BATT VOLT LOW] RL	—	—	—	×	
C1729: VHCL SPEED SIG ERR	—	—	—	×	WT-32
C1734: CONTROL UNIT	—	—	—	×	WT-34

WITHOUT INTELLIGENT KEY

WITHOUT INTELLIGENT KEY : Reference Value

INFOID:000000005185907

VALUES ON THE DIAGNOSIS TOOL

Monitor Item	Condition	Value/Status
IGN ON SW	Ignition switch OFF or ACC	Off
	Ignition switch ON	On
KEY ON SW	Mechanical key is removed from key cylinder	Off
	Mechanical key is inserted to key cylinder	On
CDL LOCK SW	Door lock/unlock switch does not operate	Off
	Press door lock/unlock switch to the lock side	On
CDL UNLOCK SW	Door lock/unlock switch does not operate	Off
	Press door lock/unlock switch to the unlock side	On

BCM (BODY CONTROL MODULE)

< ECU DIAGNOSIS INFORMATION >

Monitor Item	Condition	Value/Status	
DOOR SW-DR	Driver's door closed	Off	A
	Driver's door opened	On	
DOOR SW-AS	Passenger door closed	Off	B
	Passenger door opened	On	
DOOR SW-RR	Rear RH door closed	Off	C
	Rear RH door opened	On	
DOOR SW-RL	Rear LH door closed	Off	D
	Rear LH door opened	On	
BACK DOOR SW	Back door closed	Off	E
	Back door opened	On	
LOCK STATUS	NOTE: The item is indicated, but not monitored.	Off	
ACC ON SW	Ignition switch OFF	Off	F
	Ignition switch ACC or ON	On	
KEYLESS LOCK	"LOCK" button of key fob is not pressed	Off	G
	"LOCK" button of key fob is pressed	On	
KEYLESS UNLOCK	"UNLOCK" button of key fob is not pressed	Off	H
	"UNLOCK" button of key fob is pressed	On	
SHOCK SENSOR	NOTE: The item is indicated, but not monitored.	NORMAL	
KEY CYL LK-SW	Other than driver door key cylinder LOCK position	Off	I
	Driver door key cylinder LOCK position	On	
KEY CYL UN-SW	Other than driver door key cylinder UNLOCK position	Off	J
	Driver door key cylinder UNLOCK position	On	
VEHICLE SPEED	While driving	Equivalent to speedometer reading	
REAR DEF SW	Rear window defogger switch OFF	Off	K
	Rear window defogger switch ON	On	
REVERSE SW CAN	NOTE: The item is indicated, but not used.	Off	EXL
		On	
TAIL LAMP SW	Lighting switch OFF	Off	M
	Lighting switch 1ST	On	
FR FOG SW	Front fog lamp switch OFF	Off	N
	Front fog lamp switch ON	On	
BUCKLE SW	The seat belt (driver side) is fastened. [Seat belt switch (driver side) OFF]	Off	O
	The seat belt (driver side) is unfastened. [Seat belt switch (driver side) ON]	On	
TRNK/HAT MNTR	NOTE: The item is indicated, but not monitored.	Off	P
ACC SW	Ignition switch OFF	Off	
	Ignition switch ACC or ON	On	
KYLS TRNK/HAT	NOTE: The item is indicated, but not monitored.	Off	
KEYLESS PANIC	PANIC button of key fob is not pressed	Off	
	PANIC button of key fob is pressed	On	
HI BEAM SW	Lighting switch OFF	Off	
	Lighting switch HI	On	

BCM (BODY CONTROL MODULE)

< ECU DIAGNOSIS INFORMATION >

Monitor Item	Condition	Value/Status
HEAD LAMP SW 1	Lighting switch OFF	Off
	Lighting switch 2ND	On
HEAD LAMP SW 2	Lighting switch OFF	Off
	Lighting switch 2ND	On
AUTO LIGHT SW	Lighting switch OFF	Off
	Lighting switch AUTO	On
PASSING SW	Other than lighting switch PASS	Off
	Lighting switch PASS	On
RR FOG SW	NOTE: The item is indicated, but not monitored.	Off
TURN SIGNAL R	Turn signal switch OFF	Off
	Turn signal switch RH	On
TURN SIGNAL L	Turn signal switch OFF	Off
	Turn signal switch LH	On
PKB SW	Parking brake switch is OFF	Off
	Parking brake switch is ON	On
ENGINE RUN	Engine stopped	Off
	Engine running	On
OPTI SEN (DTCT)	Bright outside of the vehicle	Close to 5 V
	Dark outside of the vehicle	Close to 0 V
OPTI SEN (FILT)	Bright outside of the vehicle (Lighting switch AUTO)	Close to 5 V
	Dark outside of the vehicle (Lighting switch AUTO)	Close to 1.50 V
LIG SEN COND	NOTE: The item is indicated, but not monitored.	OFF
IGN SW CAN	Ignition switch OFF or ACC	Off
	Ignition switch ON	On
FR WIPER HI	Front wiper switch OFF	Off
	Front wiper switch HI	On
FR WIPER LOW	Front wiper switch OFF	Off
	Front wiper switch LO	On
FR WIPER INT	Front wiper switch OFF	Off
	Front wiper switch INT	On
FR WASHER SW	Front washer switch OFF	Off
	Front washer switch ON	On
INT VOLUME	Wiper intermittent dial is in a dial position 1 - 7	1 - 7
FR WIPER STOP	Any position other than front wiper stop position	Off
	Front wiper stop position	On
RR WIPER ON	Rear wiper switch OFF	Off
	Rear wiper switch ON	On
RR WIPER INT	Rear wiper switch OFF	Off
	Rear wiper switch INT	On
RR WASHER SW	Rear washer switch OFF	Off
	Rear washer switch ON	On
RR WIPER STOP	Rear wiper stop position	Off
	Other than rear wiper stop position	On

BCM (BODY CONTROL MODULE)

< ECU DIAGNOSIS INFORMATION >

Monitor Item	Condition	Value/Status	
RAIN SENSOR	NOTE: The item is indicated, but not monitored.	Off	A
HAZARD SW	Hazard switch OFF	Off	B
	Hazard switch ON	On	
FAN ON SIG	Blower control dial OFF	Off	C
	Other than blower control dial OFF	On	
AIR COND SW	<ul style="list-style-type: none"> • Air conditioner OFF (A/C switch indicator OFF) (Automatic air conditioner) • A/C switch OFF (Manual air conditioner) 	Off	D
	<ul style="list-style-type: none"> • Air conditioner ON (A/C switch indicator ON) (Automatic air conditioner) • A/C switch ON (Manual air conditioner) 	On	
THERMO AMP NOTE: At models with automatic air conditioner this item is not monitored.	Ignition switch ON	Off	E
	Evaporator is extremely low temperature	On	
FR DEF SW	Other than A/C mode defroster ON position	Off	F
	A/C mode defroster ON position	On	
KEYLESS TRUNK	NOTE: The item is indicated, but not monitored.	Off	G
TRNK OPNR SW	NOTE: The item is indicated, but not monitored.	Off	H
TRNK OPN MNTR	NOTE: The item is indicated, but not monitored.	Off	
HOOD SW	Close the hood	Off	I
	Open the hood	On	
TRANSPONDER	Other than the ignition switch is ON by key registered to BCM.	Off	J
	The ignition switch is ON by key registered to BCM.	On	
INTELLI KEY	NOTE: The item is indicated, but not used.	Off	
AUTO RELOCK	NOTE: The item is indicated, but not monitored.	Off	K
OIL PRESS SW	<ul style="list-style-type: none"> • Ignition switch OFF or ACC • Engine running 	Off	EXL
	Ignition switch ON	On	
BRAKE SW	Brake pedal is not depressed	Off	M
	Brake pedal is depressed	On	

BCM (BODY CONTROL MODULE)

< ECU DIAGNOSIS INFORMATION >

TERMINAL LAYOUT

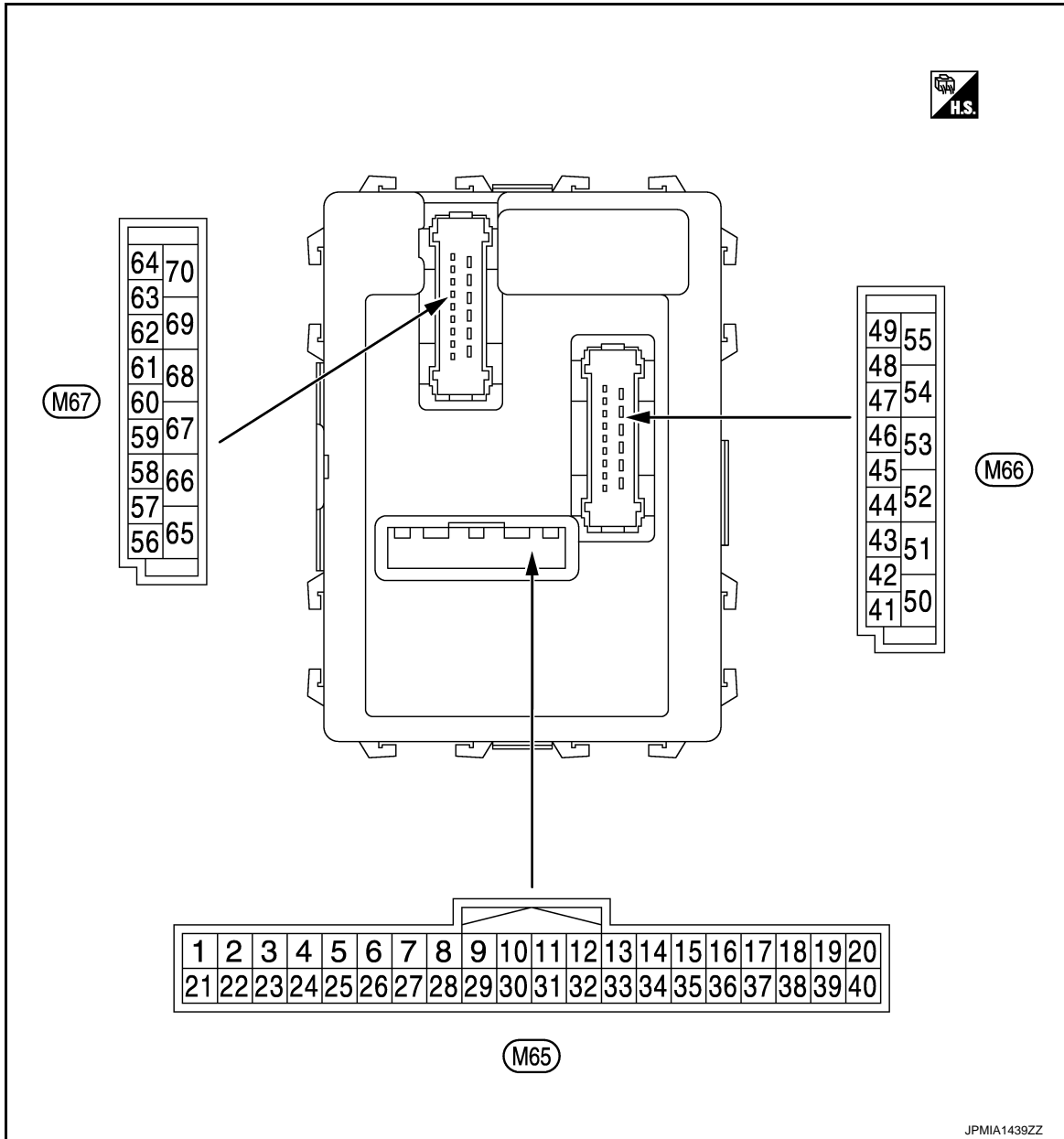

NOTE:

- M65, M66: White
- M67: Black

PHYSICAL VALUES

BCM (BODY CONTROL MODULE)

< ECU DIAGNOSIS INFORMATION >

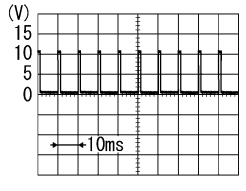
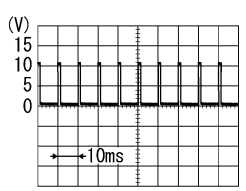
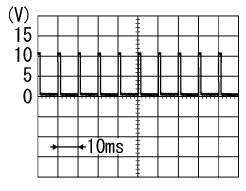
Terminal No. (Wire color)		Description		Condition	Value (Approx.)	
		Signal name	Input/ Output			
+	-					
2 (BR/W)	Ground	Combination switch INPUT 5	Input	Combination switch (Wiper intermit- tent dial 4)	All switch OFF	0 V
					Turn signal switch RH	
					Lighting switch HI	
					Lighting switch 1ST	
					Lighting switch 2ND	
3 (GR)	Ground	Combination switch INPUT 4	Input	Combination switch (Wiper intermit- tent dial 4)	All switch OFF	0 V
					Turn signal switch LH	
					Lighting switch PASS	
					Lighting switch 2ND	
					Front fog lamp switch ON	
4 (L/Y)	Ground	Combination switch INPUT 3	Input	Combination switch (Wiper intermit- tent dial 4)	All switch OFF	0 V
					Front wiper switch LO	
					Front wiper switch MIST	
					Front wiper switch INT	
					Lighting switch AUTO	

A
B
C
D
E
F
G
H
I
J
K
M
N
O
P

EXL

BCM (BODY CONTROL MODULE)

< ECU DIAGNOSIS INFORMATION >

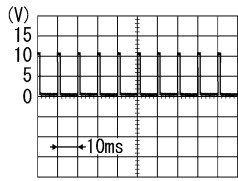
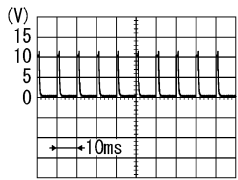
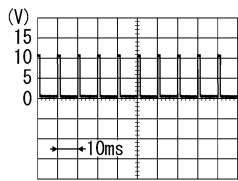
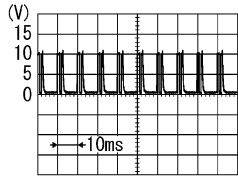
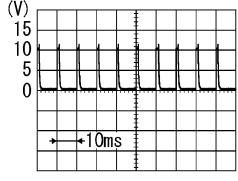
Terminal No. (Wire color)		Description		Condition	Value (Approx.)		
+	-	Signal name	Input/ Output				
5 (G)	Ground	Combination switch INPUT 2	Input	Combination switch	All switch OFF (Wiper intermittent dial 4)	0 V	
					Front washer switch (Wiper intermittent dial 4)		
					Rear washer switch ON (Wiper intermittent dial 4)		
					Any of the condition below with all switch OFF <ul style="list-style-type: none"> • Wiper intermittent dial 1 • Wiper intermittent dial 5 • Wiper intermittent dial 6 		1.0 V
					Rear wiper switch ON (Wiper intermittent dial 4)		0.8 V
6 (L/R)	Ground	Combination switch INPUT 1	Input	Combination switch	All switch OFF (Wiper intermittent dial 4)	0 V	
					Front wiper switch HI (Wiper intermittent dial 4)		
					Rear wiper switch INT (Wiper intermittent dial 4)		
					Wiper intermittent dial 3 (All switch OFF)		1.0 V
					Any of the condition below with all switch OFF <ul style="list-style-type: none"> • Wiper intermittent dial 1 • Wiper intermittent dial 2 		1.9 V
					Any of the condition below with all switch OFF <ul style="list-style-type: none"> • Wiper intermittent dial 6 • Wiper intermittent dial 7 		0.8 V

BCM (BODY CONTROL MODULE)

< ECU DIAGNOSIS INFORMATION >

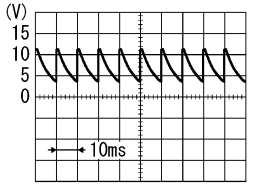
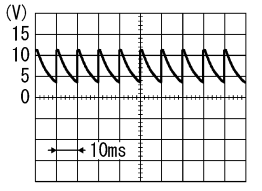
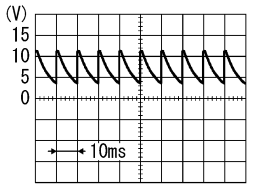
Terminal No. (Wire color)		Description		Condition	Value (Approx.)	
+	-	Signal name	Input/ Output			
7 (W/R)	Ground	Door key cylinder switch UNLOCK	Input	Door key cylinder switch	NEUTRAL position	 7.0 - 8.0 V
				UNLOCK position	0 V	
8 (W/B)	Ground	Door key cylinder switch LOCK	Input	Door key cylinder switch	NEUTRAL position	12 V
				LOCK position	0 V	
9 (R)	Ground	Stop lamp switch	Input	Stop lamp switch	OFF (Brake pedal is not depressed)	0 V
				ON (Brake pedal is de- pressed)	Battery voltage	
10 (W/L)	Ground	Rear window defog- ger switch	Input	Rear window defogger switch	OFF (Not pressed)	12 V
				ON (Pressed)	0 V	
11 (L/Y)	Ground	Ignition switch ACC	Input	Ignition switch OFF	0 V	
				Ignition switch ACC or ON	Battery voltage	
12 (SB)	Ground	Passenger door switch	Input	Passenger door switch	OFF (When passenger door closed)	 7.0 - 8.0 V
				ON (When passenger door opened)	0 V	
13 (GR/L)	Ground	Rear RH door switch	Input	Rear RH door switch	OFF (When rear RH door closed)	 7.0 - 8.0 V
				ON (When rear RH door opened)	0 V	
14 (L/B)	Ground	Optical sensor	Input	Ignition switch ON	When bright outside of the vehicle	Close to 5 V
				When dark outside of the vehicle	Close to 0 V	

A
B
C
D
E
F
G
H
I
J
K
EXL
M
N
O
P

BCM (BODY CONTROL MODULE)

< ECU DIAGNOSIS INFORMATION >

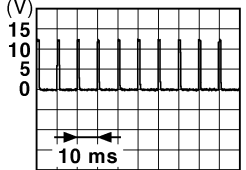
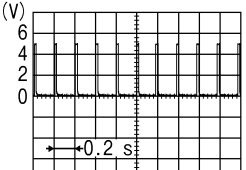
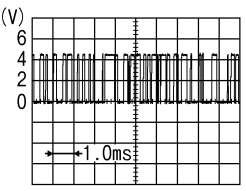
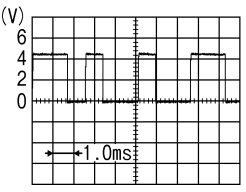
Terminal No. (Wire color)		Description		Condition		Value (Approx.)
+	-	Signal name	Input/ Output			
15 (V/W)	Ground	Tire pressure warning check switch	Input	Ignition switch OFF		 <p style="text-align: right; font-size: small;">JPMA0012GB</p> <p style="text-align: center;">1.0 - 1.5 V</p>
17 (R/G)	Ground	Optical sensor power supply	Output	Ignition switch	OFF, ACC	0 V
					ON	5 V
18 (V)	Ground	Receiver and sensor ground	Input	Ignition switch ON		0 V
19 (BR)	Ground	Remote keyless entry receiver power supply	Input	Ignition switch OFF	Insert mechanical key into ignition key cylinder	0 V
					Remove mechanical key from ignition key cylinder (Any door opened)	5 V
					Remove mechanical key from ignition key cylinder (Any door closed)	 <p style="text-align: right; font-size: small;">JPMA0338JP</p>
20 (G/Y)	Ground	Remote keyless entry receiver communication	Input	Ignition switch OFF	Insert mechanical key into ignition key cylinder	0 V
					Waiting	 <p style="text-align: right; font-size: small;">PIIB7728J</p>
					Signal receiving	 <p style="text-align: right; font-size: small;">PIIB7729J</p>
21 (P/L)	Ground	Immobilizer antenna (Clock)	Input/ Output	During waiting	Ignition switch is pressed while inserting the key into the key slot.	Just after pressing ignition switch. Pointer of tester should move.

BCM (BODY CONTROL MODULE)

< ECU DIAGNOSIS INFORMATION >

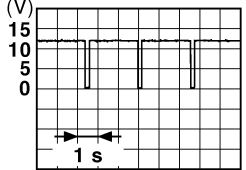
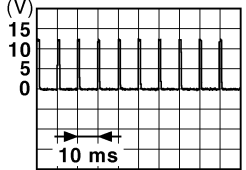
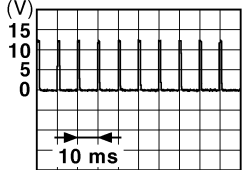
Terminal No. (Wire color)		Description		Condition		Value (Approx.)
+	-	Signal name	Input/ Output			
23 (R/Y)	Ground	Security indicator	Input	Security indicator	ON	0 V
					Blinking (Ignition switch OFF)	 <p style="text-align: right; font-size: small;">JPMIA0014GB</p>
					OFF	12 V
24 (GR/R)	Ground	Dongle link	Input/ Output	Ignition switch OFF		5 V
25 (LG)	Ground	Immobilizer antenna (Rx, Tx)	Input/ Output	During waiting	Ignition switch is pressed while inserting the key into the key slot.	Just after pressing ignition switch. Pointer of tester should move.
26*1 (GR)	Ground	Thermo control amp.	Input	Ignition switch ON		0 V
				Evaporator is extremely low temperature		12 V
27 (Y/G)*2 (Y/R)*3	Ground	A/C switch (Automatic air conditioner)	Input	A/C	OFF (A/C switch indicator: OFF)	 <p style="text-align: right; font-size: small;">JPMIA0012GB</p>
				ON (A/C switch indicator: ON)	0 V	
		A/C switch (Manual air conditioner)	Input	A/C switch	OFF	 <p style="text-align: right; font-size: small;">JPMIA0012GB</p>
				ON	0 V	

A
B
C
D
E
F
G
H
I
J
K
L
M
N
O
P

EXL

BCM (BODY CONTROL MODULE)

< ECU DIAGNOSIS INFORMATION >

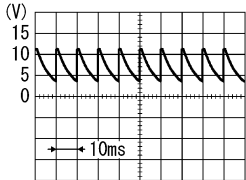
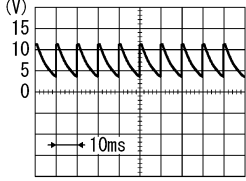
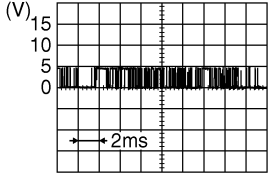
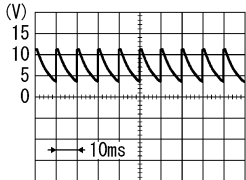
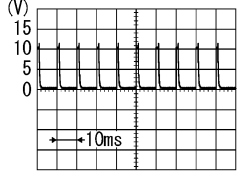
Terminal No. (Wire color)		Description		Condition	Value (Approx.)	
+	-	Signal name	Input/ Output			
28 (G/W)	Ground	Blower fan switch (Automatic air conditioner)	Input	Fan switch	Blower fan switch OFF	0 V
				Fan switch	Blower fan switch ON	 7.0 - 8.0 V
		Blower fan switch (Manual air conditioner)	Fan switch	Fan switch	Blower fan switch OFF	 7.0 - 8.0 V
				Fan switch	Blower fan switch ON	0 V
29 (L/W)	Ground	Hazard switch	Input	Hazard switch	OFF	Battery voltage
				Hazard switch	ON	0 V
31 (G/Y)	Ground	Front defroster switch	Input	Ignition switch ON	A/C mode defroster ON position	0 V
				Ignition switch ON	Other than A/C mode defroster ON position	 8.0 - 9.0 V
32 (LG)	Ground	Combination switch OUTPUT 5	Output	Combination switch	All switch OFF (Wiper intermittent dial 4)	 7.0 - 8.0 V
				Combination switch	Front fog lamp switch ON (Wiper intermittent dial 4)	 1.0 V
				Combination switch	Rear wiper switch ON (Wiper intermittent dial 4)	
Combination switch	Any of the condition below with all switch OFF	<ul style="list-style-type: none"> • Wiper intermittent dial 1 • Wiper intermittent dial 2 • Wiper intermittent dial 6 • Wiper intermittent dial 7 				

BCM (BODY CONTROL MODULE)

< ECU DIAGNOSIS INFORMATION >

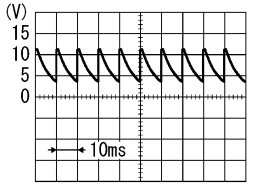
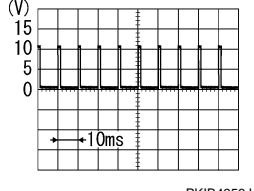
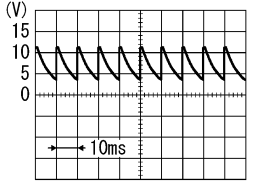
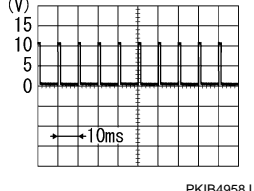
Terminal No. (Wire color)		Description		Condition	Value (Approx.)	
+	-	Signal name	Input/ Output			
33 (Y/L)	Ground	Combination switch OUTPUT 4	Output	Combination switch	All switch OFF (Wiper intermittent dial 4)	 <p style="text-align: center;">7.0 - 8.0 V</p>
					Lighting switch 1ST (Wiper intermittent dial 4)	 <p style="text-align: center;">1.2 V</p>
					Lighting switch AUTO (Wiper intermittent dial 4)	
					Rear wiper switch INT (Wiper intermittent dial 4)	
Any of the condition below with all switch OFF						
<ul style="list-style-type: none"> • Wiper intermittent dial 1 • Wiper intermittent dial 5 • Wiper intermittent dial 6 						
34 (W)	Ground	Combination switch OUTPUT 3	Output	Combination switch	All switch OFF (Wiper intermittent dial 4)	 <p style="text-align: center;">7.0 - 8.0 V</p>
					Lighting switch 2ND (Wiper intermittent dial 4)	 <p style="text-align: center;">1.2 V</p>
					Lighting switch HI (Wiper intermittent dial 4)	
					Rear washer switch ON (Wiper intermittent dial 4)	
Any of the condition below with all switch OFF						
<ul style="list-style-type: none"> • Wiper intermittent dial 1 • Wiper intermittent dial 2 • Wiper intermittent dial 3 						

A
B
C
D
E
F
G
H
I
J
K
L
M
N
O
P

EXL

BCM (BODY CONTROL MODULE)

< ECU DIAGNOSIS INFORMATION >

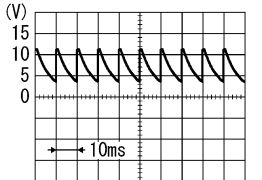
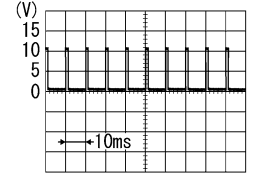
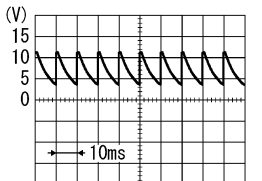
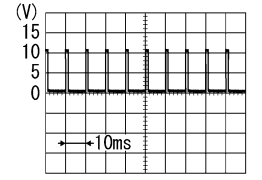
Terminal No. (Wire color)		Description		Condition	Value (Approx.)	
+	-	Signal name	Input/ Output			
35 (R/L)	Ground	Combination switch OUTPUT 2	Output	Combination switch (Wiper intermit- tent dial 4)	All switch OFF	 <p style="text-align: center;">7.0 - 8.0 V</p>
					Lighting switch 2ND	 <p style="text-align: center;">1.2 V</p>
					Lighting switch PASS	
					Front wiper switch INT	
Front wiper switch HI						
36 (L/O)	Ground	Combination switch OUTPUT 1	Output	Combination switch (Wiper intermit- tent dial 4)	All switch OFF	 <p style="text-align: center;">7.0 - 8.0 V</p>
					Turn signal switch RH	 <p style="text-align: center;">1.2 V</p>
					Turn signal switch LH	
					Front wiper switch LO (Front wiper switch MIST)	
Front washer switch ON						
37 (R/W)	Ground	Key switch	Input	Insert mechanical key into ignition key cylinder	Battery voltage	
				Remove mechanical key from ignition key cylinder	0 V	
38 (O)	Ground	Ignition switch ON	Input	Ignition switch OFF or ACC	0 V	
				Ignition switch ON	Battery voltage	
39 (L)	Ground	CAN-H	Input/ Output	—	—	
40 (P)	Ground	CAN-L	Input/ Output	—	—	

BCM (BODY CONTROL MODULE)

< ECU DIAGNOSIS INFORMATION >

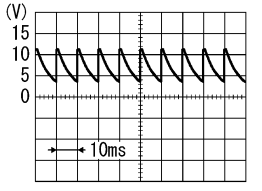
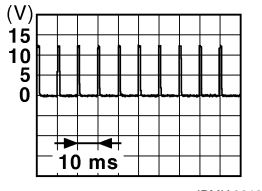
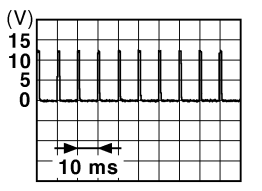
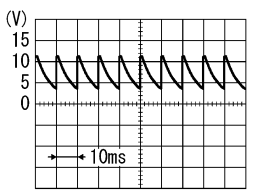
Terminal No. (Wire color)		Description		Condition	Value (Approx.)
+	-	Signal name	Input/ Output		
43 (W)	Ground	Back door switch	Input	Back door switch	 <p style="text-align: center;">7.0 - 8.0 V</p>
				OFF (When back door closed)	0 V
44 (LG)	Ground	Rear wiper stop position	Input	Ignition switch ON	12 V
				Rear wiper stop position	0 V
45 (GR)	Ground	Door lock and unlock switch LOCK	Input	Door lock and unlock switch	 <p style="text-align: center;">1.0 - 1.5 V</p>
				NEUTRAL position	0 V
46 (BR)	Ground	Door lock and unlock switch UNLOCK	Input	Door lock and unlock switch	 <p style="text-align: center;">1.0 - 1.5 V</p>
				NEUTRAL position	0 V
47 (BR/Y)	Ground	Driver door switch	Input	Driver door switch	 <p style="text-align: center;">7.0 - 8.0 V</p>
				OFF (When driver door closed)	0 V
				ON (When driver door opened)	0 V

A
B
C
D
E
F
G
H
I
J
K
EXL
M
N
O
P

BCM (BODY CONTROL MODULE)

< ECU DIAGNOSIS INFORMATION >

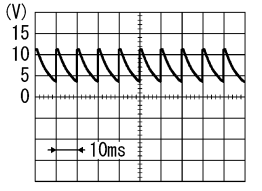
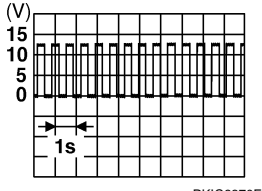
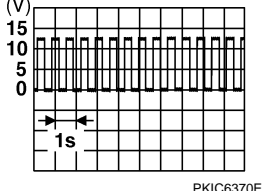
Terminal No. (Wire color)		Description		Condition		Value (Approx.)
+	-	Signal name	Input/ Output			
48 (W/G)	Ground	Rear LH door switch	Input	Rear LH door switch	OFF (When rear LH door closed)	 7.0 - 8.0 V
					ON (When rear LH door opened)	0 V
49 (Y)	Ground	Luggage room lamp	Output	Luggage room lamp switch DOOR position	Back door is closed (Back door lamp turns OFF)	12 V
					Back door is opened (Back door lamp turns ON)	0 V
50*1 (SB)	Ground	A/C indicator	Output	A/C indicator	OFF	12 V
					ON	0 V
54 (L/W)	Ground	Rear wiper	Output	Ignition switch ON	Rear wiper switch OFF	0 V
					Rear wiper switch ON	12 V
56 (L)	Ground	Interior room lamp power supply	Output	Interior room lamp battery saver is activated. (Cuts the interior room lamp power supply)	0 V	
					Interior room lamp battery saver is not activated. (Outputs the interior room lamp power supply)	12 V
57 (Y)	Ground	Battery power supply	Input	Ignition switch OFF	Battery voltage	
59 (L/B)	Ground	Driver door UN-LOCK	Output	Driver door	UNLOCK (Actuator is activated)	12 V
					Other than UNLOCK (Actuator is not activated)	0 V
60 (W/B)	Ground	Turn signal LH	Output	Ignition switch ON	Turn signal switch OFF	0 V
					Turn signal switch LH	 6.0 V
61 (W/L)	Ground	Turn signal RH	Output	Ignition switch ON	Turn signal switch OFF	0 V
					Turn signal switch RH	 6.0 V

BCM (BODY CONTROL MODULE)

< ECU DIAGNOSIS INFORMATION >

Terminal No. (Wire color)		Description		Condition		Value (Approx.)
+	-	Signal name	Input/ Output			
63 (BR)	Ground	Interior room lamp timer control	Output	Interior room lamp	OFF	12 V
					ON	0 V
65 (V)	Ground	All doors LOCK	Output	All doors	LOCK (Actuator is activated)	12 V
					Other then LOCK (Actuator is not activated)	0 V
66 (G)	Ground	Passenger door and rear door UNLOCK	Output	Passenger door and rear door	UNLOCK (Actuator is activated)	12 V
					Other then UNLOCK (Actuator is not activated)	0 V
67 (B)	Ground	Ground	Output	Ignition switch ON		0 V
68 (L)	Ground	P/W power supply (IGN)	Output	Ignition switch ON		12 V
69 (L/W)	Ground	P/W power supply (BAT)	Output	Ignition switch OFF		12 V
70 (Y)	Ground	Battery power supply	Input	Ignition switch OFF		Battery voltage

- *1: Only manual air conditioner
- *2: Automatic air conditioner
- *3: Manual air conditioner

A
B
C
D
E
F
G
H
I
J
K
L
M
N
O
P

EXL

BCM (BODY CONTROL MODULE)

< ECU DIAGNOSIS INFORMATION >

WITHOUT INTELLIGENT KEY : Wiring Diagram - BCM -

INFOID:000000005185908

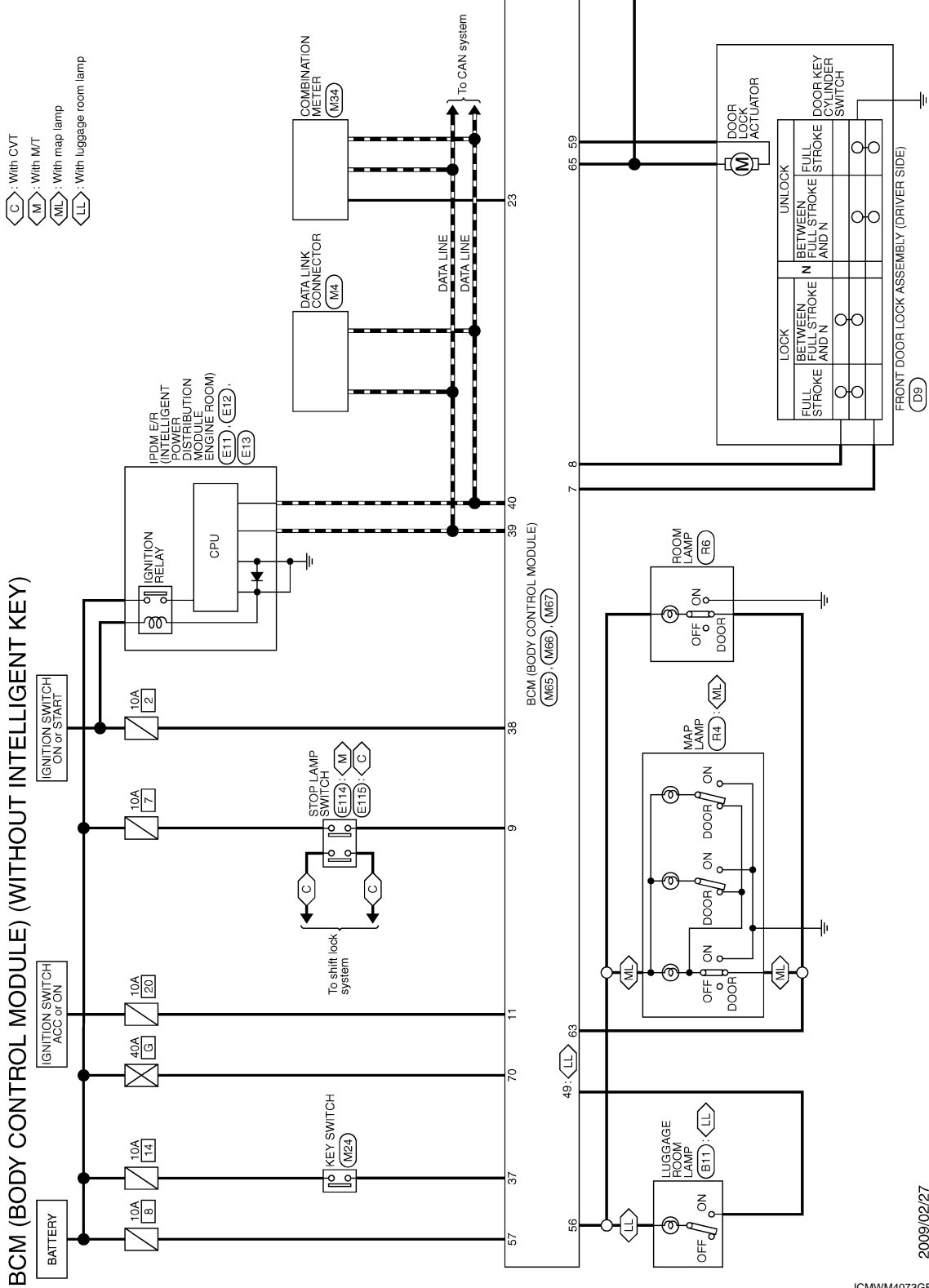

2009/02/27

JCMWM4073GB

BCM (BODY CONTROL MODULE)

< ECU DIAGNOSIS INFORMATION >

- AA: With auto A/C
- MA: With manual A/C
- OA: Without A/C
- XA: Except with auto A/C
- AL: With auto light system

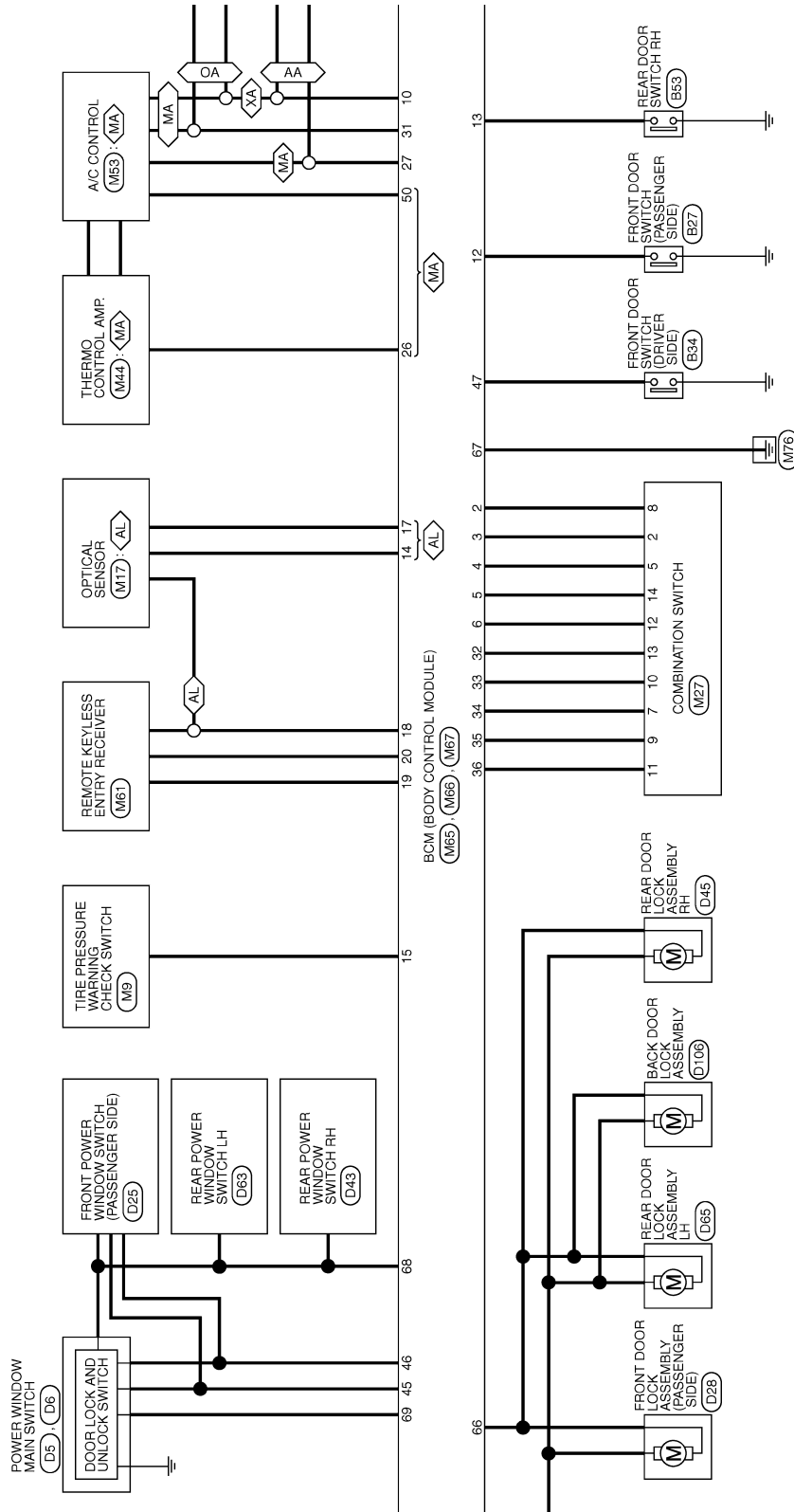

JCMWM4074GB

A
B
C
D
E
F
G
H
I
J
K
EXL
M
N
O
P

BCM (BODY CONTROL MODULE)

< ECU DIAGNOSIS INFORMATION >

- : For Canada
- : With auto A/C
- : Without A/C
- : Except with auto A/C

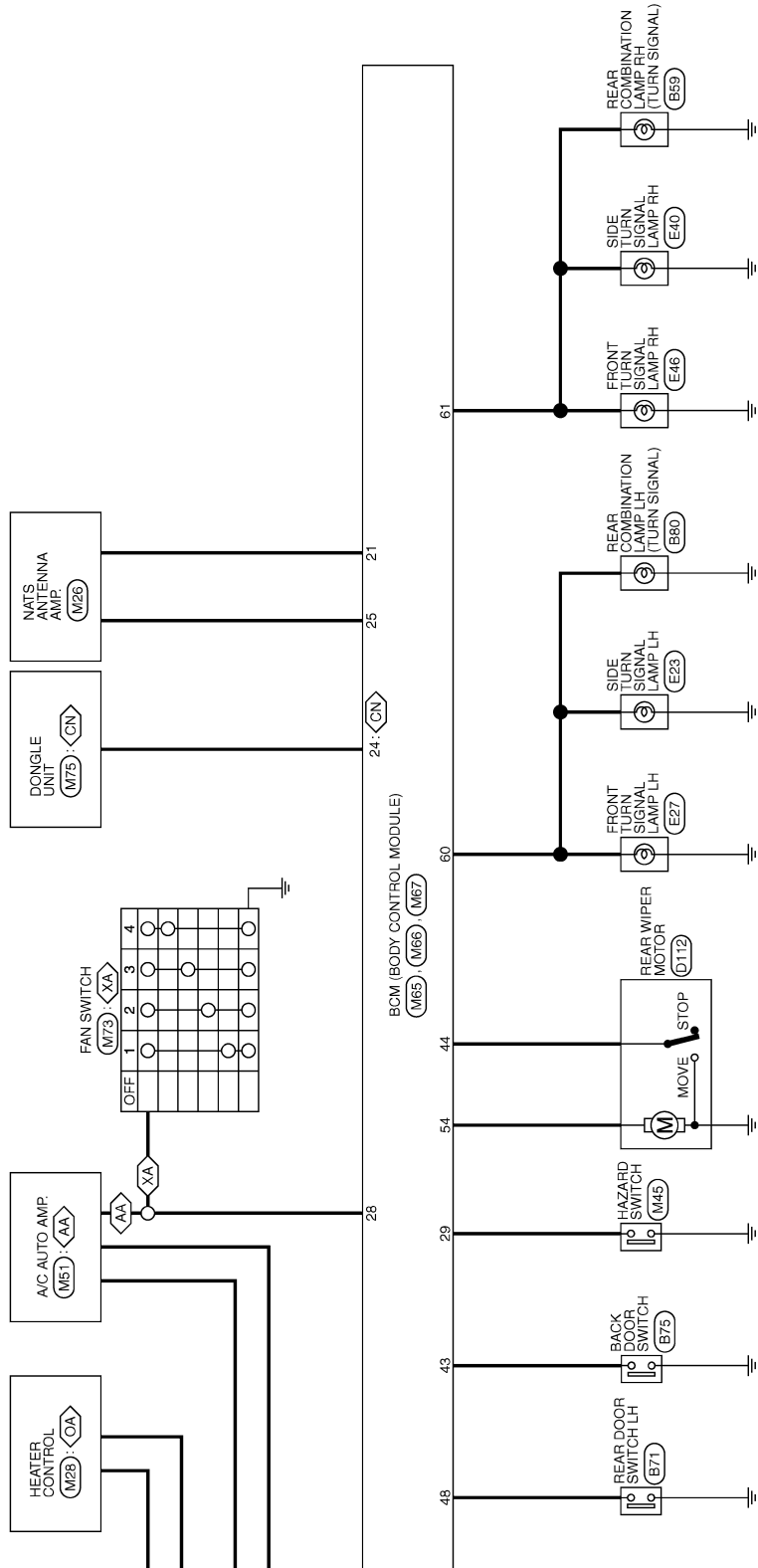

JCMWM4075GB

BCM (BODY CONTROL MODULE)

< ECU DIAGNOSIS INFORMATION >

40 P CAN-L

13	GR/L	REAR RH DOOR SW
14	L/B	OPTICAL SENSOR
15	V/W	TIRE PRESS WARNING CHECK SW
17	R/G	OPTICAL SENSOR POWER SUPPLY
18	V	RECEIVER SENSOR GND
19	BR	KEYLESS ENTRY RECEIVER POWER SUPPLY
20	G/Y	KEYLESS ENTRY RECEIVER COMM
21	P/L	NATS ANTENNA AMP
23	R/Y	SECURITY INDICATOR LAMP
24	GR/R	DOUBLE LINK
25	LG	NATS ANTENNA AMP
26	GR	THERMO CONTROL AMP
27	Y/G	A/C SW(With auto A/C)
27	Y/R	A/C SW(With manual A/C)
28	G/W	BLOWER FAN SW
28	L/W	HAZARD SW
29	L/W	FR DEFROSTER SW
31	G/Y	COMBI SW OUTPUT 4
32	LG	COMBI SW OUTPUT 5
33	Y/L	COMBI SW OUTPUT 4
34	W	COMBI SW OUTPUT 3
35	R/L	COMBI SW OUTPUT 2
36	L/O	COMBI SW OUTPUT 1
37	R/W	KEY SWITCH
38	O	IGN
39	L	CAN-H

70	Y	BAT (F/L)
----	---	-----------

BCM (BODY CONTROL MODULE) (WITHOUT INTELLIGENT KEY)

Connector No.	M65
Connector Name	BCM (BODY CONTROL MODULE) (WITHOUT INTELLIGENT KEY)
Connector Type	TH40FPV-NH

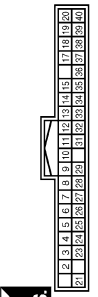

Terminal No.	Color of Wire	Signal Name [Specification]
2	BR/W	COMBI SW INPUT 5
3	GR	COMBI SW INPUT 4
4	L/Y	COMBI SW INPUT 3
5	G	COMBI SW INPUT 2
6	L/R	COMBI SW INPUT 1
7	W/R	KEY CYL UNLOCK SW
8	W/B	KEY CYL LOCK SW
9	R	STOP LAMP SW
10	W/L	REAR WINDOW DEFROGGER SW
11	L/Y	ACC
12	SB	PASSENGER DOOR SW

Connector No.	M67
Connector Name	BCM (BODY CONTROL MODULE) (WITHOUT INTELLIGENT KEY)
Connector Type	FEA09FB-FHA6-SA

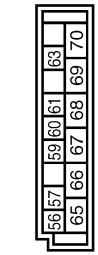

Terminal No.	Color of Wire	Signal Name [Specification]
56	L	INTERIOR ROOM LAMP POWER SUPPLY
57	Y	BAT (FUSE)
59	L/B	DRIVER DOOR UNLOCK OUTPUT
60	W/B	TURN SIGNAL LH OUTPUT
61	W/L	TURN SIGNAL RH OUTPUT
63	BR	ROOM LAMP TIMER CONTROL
65	V	ALL DOOR LOCK OUTPUT
66	G	PASSENGER DOOR REAR DOOR UNLOCK OUTPUT
67	B	GND
68	L	POWER WINDOW POWER SUPPLY (IGN)
69	L/W	POWER WINDOW POWER SUPPLY (BAT)

Connector No.	M67
Connector Name	COMBINATION SWITCH
Connector Type	TH167V-NH

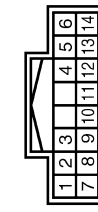

Terminal No.	Color of Wire	Signal Name [Specification]
2	GR	INPUT 4
5	L/Y	INPUT 3
7	W	OUTPUT 3
8	BR/W	INPUT 5
9	R/L	OUTPUT 2
10	Y/L	OUTPUT 4
11	L/O	OUTPUT 1
12	L/R	INPUT 1
13	LG	OUTPUT 5
14	G	INPUT 2

Connector No.	M68
Connector Name	BCM (BODY CONTROL MODULE) (WITHOUT INTELLIGENT KEY)
Connector Type	FEA09FW-FHA6-SA

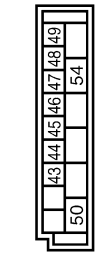

Terminal No.	Color of Wire	Signal Name [Specification]
43	W	BACK DOOR SW
44	LG	REAR WIPER STOP POSITION
45	GR	CENTRAL DOOR LOCK SW
46	BR	CENTRAL DOOR UNLOCK SW
47	BR/Y	DRIVER DOOR SW
48	W/G	REAR LH DOOR SW
49	Y	LUGGAGE ROOM LAMP
50	SB	A/C INDICATOR OUTPUT
54	L/W	REAR WIPER OUTPUT

WITHOUT INTELLIGENT KEY : Fail-safe

FAIL-SAFE CONTROL BY DTC
BCM performs fail-safe control when any DTC are detected.

A
B
C
D
E
F
G
H
I
J
K
L
M
N
O
P

EXL

JCMWM4076GB

INFOID:000000005185909

BCM (BODY CONTROL MODULE)

< ECU DIAGNOSIS INFORMATION >

Display contents of CONSULT	Fail-safe	Cancellation
B2190: NATS ANTENNA AMP	Inhibit engine cranking	Erase DTC
B2191: DIFFERENCE OF KEY	Inhibit engine cranking	Erase DTC
B2192: ID DISCORD BCM-ECM	Inhibit engine cranking	Erase DTC
B2193: CHAIN OF BCM-ECM	Inhibit engine cranking	Erase DTC
B2195: ANTI SCANNING	Inhibit engine cranking	Ignition switch ON → OFF
B2196: DONGLE NG	Inhibit engine cranking	Erase DTC

REAR WIPER MOTOR PROTECTION

BCM detects the rear wiper stopping position according to the rear wiper auto stop signal.

When the rear wiper auto stop signal does not change more than 5 seconds while driving the rear wiper, BCM stops power supply to protect the rear wiper motor.

Condition of cancellation

1. Pass more than 1 minute after the rear wiper stop.
2. Turn rear wiper switch OFF.
3. Operate the rear wiper switch or rear washer switch.

HIGH FLASHER OPERATION

BCM detects the turn signal lamp circuit status by the current value.

BCM increases the turn signal lamp blinking speed if the bulb or harness open is detected with the turn signal lamp operating.

NOTE:

The blinking speed is normal while activating the hazard warning lamp.

WITHOUT INTELLIGENT KEY : DTC Inspection Priority Chart

INFOID:000000005185910

If some DTCs are displayed at the same time, perform inspections one by one based on the following priority chart.

Priority	DTC
1	<ul style="list-style-type: none">• U1000: CAN COMM• U1010: CONTROL UNIT (CAN)
2	<ul style="list-style-type: none">• B2190: NATS ANTENNA AMP• B2191: DIFFERENCE OF KEY• B2192: ID DISCORD BCM-ECM• B2193: CHAIN OF BCM-ECM• B2195: ANTI SCANNING• B2196: DONGLE NG

BCM (BODY CONTROL MODULE)

< ECU DIAGNOSIS INFORMATION >

Priority	DTC	
3	C1735: IGN CIRCUIT OPEN	A
4	<ul style="list-style-type: none"> • C1704: LOW PRESSURE FL • C1705: LOW PRESSURE FR • C1706: LOW PRESSURE RR • C1707: LOW PRESSURE RL • C1708: [NO DATA] FL • C1709: [NO DATA] FR • C1710: [NO DATA] RR • C1711: [NO DATA] RL • C1712: [CHECKSUM ERR] FL • C1713: [CHECKSUM ERR] FR • C1714: [CHECKSUM ERR] RR • C1715: [CHECKSUM ERR] RL • C1716: [PRESSDATA ERR] FL • C1717: [PRESSDATA ERR] FR • C1718: [PRESSDATA ERR] RR • C1719: [PRESSDATA ERR] RL • C1720: [CODE ERR] FL • C1721: [CODE ERR] FR • C1722: [CODE ERR] RR • C1723: [CODE ERR] RL • C1724: [BATT VOLT LOW] FL • C1725: [BATT VOLT LOW] FR • C1726: [BATT VOLT LOW] RR • C1727: [BATT VOLT LOW] RL • C1729: VHCL SPEED SIG ERR • C1734: CONTROL UNIT 	<p>B</p> <p>C</p> <p>D</p> <p>E</p> <p>F</p> <p>G</p> <p>H</p>

WITHOUT INTELLIGENT KEY : DTC Index

INFOID:000000005185911

NOTE:

- Details of time display
- CRNT: Displays when there is a malfunction now or after returning to the normal condition until turning ignition switch OFF → ON again.
- 1 - 39: Displayed if any previous malfunction is present when current condition is normal. It increases like 1 → 2 → 3...38 → 39 after returning to the normal condition whenever ignition switch OFF → ON. The counter remains at 39 even if the number of cycles exceeds it. It is counted from 1 again when turning ignition switch OFF → ON after returning to the normal condition if the malfunction is detected again.

EXL

M

N

O

P

CONSULT display	Fail-safe	Tire pressure monitor warning lamp ON	Reference
U1000: CAN COMM	—	—	BCS-116
U1010: CONTROL UNIT (CAN)	—	—	BCS-117
B2190: NATS ANTENNA AMP	×	—	SEC-217
B2191: DIFFERENCE OF KEY	×	—	SEC-220
B2192: ID DISCORD BCM-ECM	×	—	SEC-221
B2193: CHAIN OF BCM-ECM	×	—	SEC-223
B2195: ANTI SCANNING	×	—	SEC-224
B2196: DONGLE NG	×	—	SEC-225
C1704: LOW PRESSURE FL	—	×	WT-16
C1705: LOW PRESSURE FR	—	×	
C1706: LOW PRESSURE RR	—	×	
C1707: LOW PRESSURE RL	—	×	

BCM (BODY CONTROL MODULE)

< ECU DIAGNOSIS INFORMATION >

CONSULT display	Fail-safe	Tire pressure monitor warn- ing lamp ON	Reference
C1708: [NO DATA] FL	—	×	WT-18
C1709: [NO DATA] FR	—	×	
C1710: [NO DATA] RR	—	×	
C1711: [NO DATA] RL	—	×	
C1712: [CHECKSUM ERR] FL	—	×	WT-21
C1713: [CHECKSUM ERR] FR	—	×	
C1714: [CHECKSUM ERR] RR	—	×	
C1715: [CHECKSUM ERR] RL	—	×	
C1716: [PRESS DATA ERR] FL	—	×	WT-24
C1717: [PRESS DATA ERR] FR	—	×	
C1718: [PRESS DATA ERR] RR	—	×	
C1719: [PRESS DATA ERR] RL	—	×	
C1720: [CODE ERR] FL	—	×	WT-26
C1721: [CODE ERR] FR	—	×	
C1722: [CODE ERR] RR	—	×	
C1723: [CODE ERR] RL	—	×	
C1724: [BATT VOLT LOW] FL	—	×	WT-29
C1725: [BATT VOLT LOW] FR	—	×	
C1726: [BATT VOLT LOW] RR	—	×	
C1727: [BATT VOLT LOW] RL	—	×	
C1729: VHCL SPEED SIG ERR	—	×	WT-32
C1734: CONTROL UNIT	—	×	WT-34
C1735: IGN CIRCUIT OPEN	—	—	BCS-118

IPDM E/R (INTELLIGENT POWER DISTRIBUTION MODULE ENGINE ROOM)

< ECU DIAGNOSIS INFORMATION >

IPDM E/R (INTELLIGENT POWER DISTRIBUTION MODULE ENGINE ROOM)

WITH INTELLIGENT KEY

WITH INTELLIGENT KEY : Reference Value

INFOID:000000005189743

VALUES ON THE DIAGNOSIS TOOL

Monitor Item	Condition		Value/Status
MOTOR FAN REQ	Engine idle speed	Changes depending on engine coolant temperature, air conditioner operation status, vehicle speed, etc.	1/2/3/4
AC COMP REQ	Engine running	A/C switch OFF	Off
		A/C switch ON (Compressor is operating)	On
TAIL&CLR REQ	Lighting switch OFF		Off
	Lighting switch 1ST, 2ND, HI or AUTO (Light is illuminated)		On
HL LO REQ	Lighting switch OFF		Off
	Lighting switch 2ND, HI or AUTO (Light is illuminated)		On
HL HI REQ	Lighting switch OFF		Off
	Lighting switch HI		On
FR FOG REQ	Lighting switch 2ND or AUTO (Light is illuminated)	Front fog lamp switch OFF	Off
		Front fog lamp switch ON	On
FR WIP REQ	Ignition switch ON	Front wiper switch OFF	Stop
		Front wiper switch INT	1LOW
		Front wiper switch LO	Low
		Front wiper switch HI	Hi
WIP AUTO STOP	Ignition switch ON	Front wiper stop position	STOP P
		Any position other than front wiper stop position	ACT P
WIP PROT	Ignition switch ON	Front wiper operates normally	Off
		Front wiper stops at fail-safe operation	BLOCK
IGN RLY1 -REQ	Ignition switch OFF or ACC		Off
	Ignition switch ON		On
IGN RLY	Ignition switch OFF or ACC		Off
	Ignition switch ON		On
PUSH SW	Release the push-button ignition switch		Off
	Press the push-button ignition switch		On
INTER/NP SW	Ignition switch ON	<ul style="list-style-type: none"> Selector lever in any position other than P or N (CVT models) Release clutch pedal (M/T models) 	Off
		<ul style="list-style-type: none"> Selector lever in P or N position (CVT models) Depress clutch pedal (M/T models) 	On
ST RLY CONT	Ignition switch ON		Off
	At engine cranking		On

A
B
C
D
E
F
G
H
I
J
K
L
M
N
O
P

EXL

IPDM E/R (INTELLIGENT POWER DISTRIBUTION MODULE ENGINE ROOM)

< ECU DIAGNOSIS INFORMATION >

Monitor Item	Condition	Value/Status
IHBT RLY -REQ	Ignition switch ON	Off
	At engine cranking	On
ST/INHI RLY	Ignition switch ON	Off
	At engine cranking	INHI ON → ST ON
	The status of starter relay or starter control relay cannot be recognized by the battery voltage malfunction, etc. when the starter relay is ON and the starter control relay is OFF	UNKWN
DETENT SW	Ignition switch ON <ul style="list-style-type: none"> • Pull the selector lever with selector lever in P position • Selector lever in any position other than P 	Off
	Release the selector lever with selector lever in P position NOTE: Fixed On for M/T models	On
S/L RLY -REQ	None of the conditions below are present	Off
	<ul style="list-style-type: none"> • Open the driver door after the ignition switch is turned OFF (for a few seconds) • Press the push-button ignition switch when the steering lock is activated 	On
S/L STATE	Steering lock is activated	LOCK
	Steering lock is deactivated	UNLOCK
	[DTC: B210A] is detected	UNKWN
DTRL REQ NOTE: This item is monitored only on the vehicle with the daytime running light system.	Not operation	Off
	Daytime running light system is operated.	On
OIL P SW	Ignition switch OFF, ACC or engine running	Open
	Ignition switch ON	Close
HOOD SW	NOTE: The item is indicated, but not monitored.	Off
THFT HRN REQ	Not operation	Off
	<ul style="list-style-type: none"> • Panic alarm is activated • Horn is activated with VEHICLE SECURITY (THEFT WARNING) SYSTEM 	On
HORN CHIRP	Not operating	Off
	Door locking with Intelligent Key (horn chirp mode)	On

IPDM E/R (INTELLIGENT POWER DISTRIBUTION MODULE ENGINE ROOM)

< ECU DIAGNOSIS INFORMATION >

TERMINAL LAYOUT

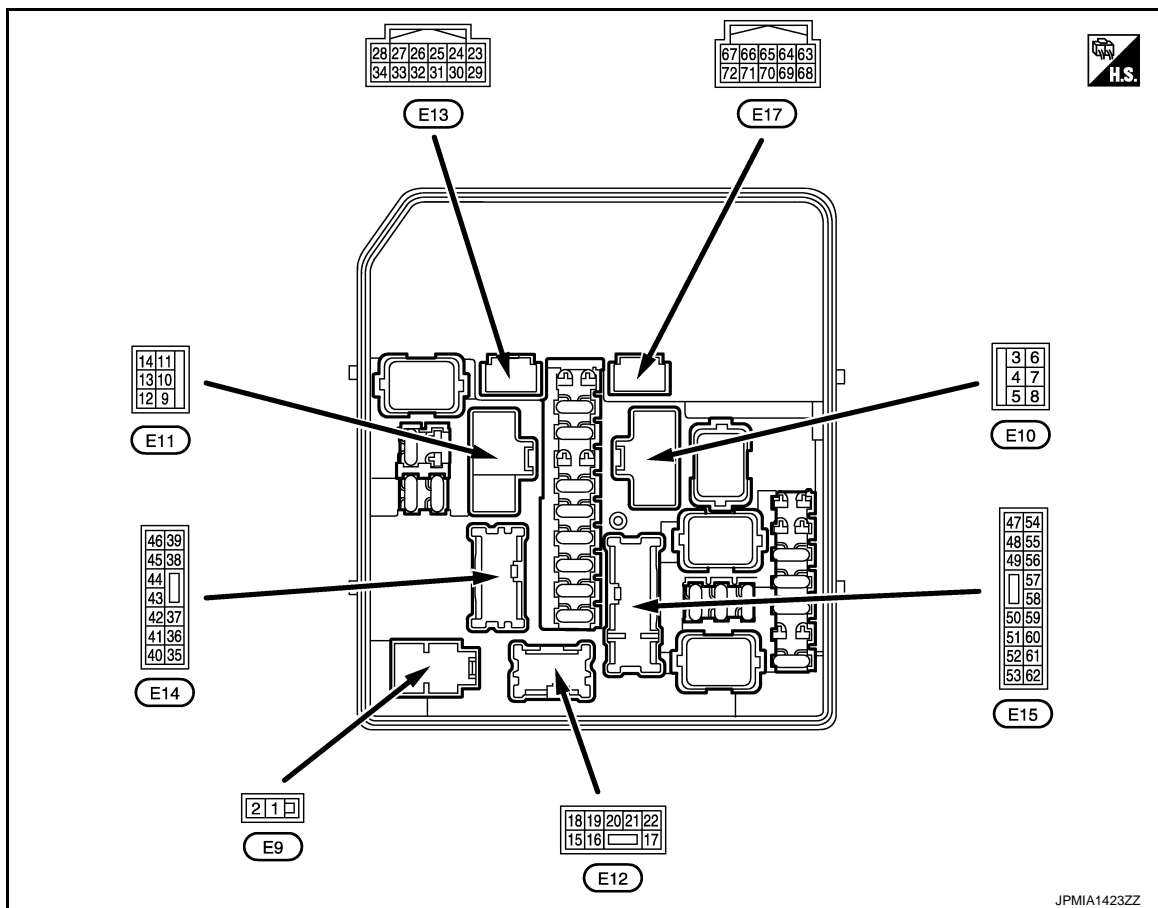

PHYSICAL VALUES

Terminal NO. (Wire color)		Description		Condition	Value (Approx.)
+	-	Signal name	Input/ Output		
1 (R)	Ground	Battery power supply	Input	Ignition switch OFF	Battery voltage
2 (G)	Ground	Battery power supply	Input	Ignition switch OFF	Battery voltage
3 (BR)	Ground	Starter motor	Output	Ignition switch ON	0 V
				At engine cranking	Battery voltage
4 (P)	Ground	Battery power supply	Input	Ignition switch OFF	Battery voltage
5 (LG)	Ground	Cooling fan relay-1 power supply	Output	Cooling fan OFF	0 V
				Cooling fan operated	Battery voltage
7 (Y)	Ground	Cooling fan relay-2 power supply	Output	Cooling fan OFF	0 V
				Cooling fan LO operated	9.0 V
				Cooling fan HI operated	Battery voltage
8 (V)	Ground	Battery power supply	Input	Ignition switch OFF	Battery voltage
9 (B/W)	Ground	Ground	—	Ignition switch ON	0 V
10 (L)	Ground	Cooling fan motor ground	Output	Cooling fan OFF	0 V
				Cooling fan LO operated	5.0 V
				Cooling fan HI operated	0 V

IPDM E/R (INTELLIGENT POWER DISTRIBUTION MODULE ENGINE ROOM)

< ECU DIAGNOSIS INFORMATION >

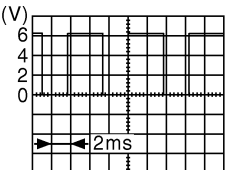
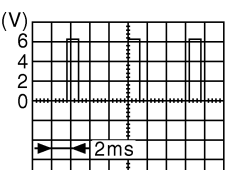
Terminal NO. (Wire color)		Description		Condition		Value (Approx.)
+	-	Signal name	Input/ Output			
13 (W)	Ground	Rear window defogger	Output	Ignition switch OFF	Rear window defogger switch OFF	0 V
				Ignition switch ON	Rear window defogger switch ON	Battery voltage
19 (B/W)	Ground	Ground	—	Ignition switch ON		0 V
21 (W)	Ground	Front fog lamp (RH)	Output	Lighting switch 2ND OFF	Front fog lamp switch OFF	0 V
				Lighting switch 2ND ON	Front fog lamp switch ON	Battery voltage
22 (V)	Ground	Front fog lamp (LH)	Output	Lighting switch 2ND OFF	Front fog lamp switch OFF	0 V
				Lighting switch 2ND ON	Front fog lamp switch ON	Battery voltage
24 (G)	Ground	Oil pressure switch	Input	Ignition switch ON	Engine stopped	0 V
				Ignition switch ON	Engine running	Battery voltage
25 (Y)	Ground	Front wiper auto stop	Input	Ignition switch ON	Front wiper stop position	0 V
				Ignition switch ON	Any position other than front wiper stop position	Battery voltage
26 (P)	Ground	CAN-L	Input/ Output	—		—
27 (L)	Ground	CAN-H	Input/ Output	—		—
28*1 (P)	Ground	Daytime running light relay-1 control	Output	Daytime running light deactivated		0 V
				Daytime running light activated		Battery voltage
30 (SB)	Ground	Starter relay control	Output	At engine cranking		0 V
				Ignition switch ON		Battery voltage
31 (W)	Ground	Fuel pump relay control	Output	<ul style="list-style-type: none"> Approximately 1 second after turning the ignition switch ON Engine running 		0 - 1.5 V
				Approximately 1 second or more after turning the ignition switch ON		Battery voltage
33 (O)	Ground	Power generation command signal	Output	Ignition switch ON		Battery voltage
				40 % is set on "ACTIVE TEST", "ALTERNATOR DUTY" of "ENGINE"		 <p style="text-align: right;">JPMA0002GB</p> <p style="text-align: center;">3.8 V</p>
				80 % is set on "ACTIVE TEST", "ALTERNATOR DUTY" of "ENGINE"		 <p style="text-align: right;">JPMA0003GB</p> <p style="text-align: center;">1.4 V</p>

IPDM E/R (INTELLIGENT POWER DISTRIBUTION MODULE ENGINE ROOM)

< ECU DIAGNOSIS INFORMATION >

Terminal NO. (Wire color)		Description		Condition	Value (Approx.)		
		Signal name	Input/ Output				
+	-						
34 (R)	Ground	Horn relay control	Output	The horn is deactivated	Battery voltage	A	
				The horn is activated	0 V	B	
36 (O)	Ground	Parking lamp (LH)	Output	Ignition switch ON	Lighting switch OFF	0 V	
					Lighting switch 1ST	Battery voltage	C
37 (V)	Ground	Parking lamp (RH)	Output	Ignition switch ON	Lighting switch OFF	0 V	
					Lighting switch 1ST	Battery voltage	D
38 (G)	Ground	Tail lamp (RH) & illuminations	Output	Ignition switch ON	Lighting switch OFF	0 V	
					Lighting switch 1ST	Battery voltage	E
39 (V)	Ground	Front wiper HI	Output	Ignition switch ON	Front wiper switch OFF	0 V	
					Front wiper switch HI	Battery voltage	F
40 (R)	Ground	ECM relay control	Output	Ignition switch OFF (More than a few seconds after turning ignition switch OFF)	Battery voltage	G	
				<ul style="list-style-type: none"> • Ignition switch ON • Ignition switch OFF (For a few seconds after turning ignition switch OFF) 	0 - 1.5 V	H	
41 (SB)	Ground	Tail lamp (LH) & license plate lamps	Output	Ignition switch ON	Lighting switch OFF	0 V	
					Lighting switch 1ST	Battery voltage	I
42 (W)	Ground	Steering lock unit power supply	Output	Ignition switch ACC or ON	0 V	J	
				Ignition switch ON	A few seconds after opening the driver door	Battery voltage	K
				Ignition switch LOCK	Press the push-button ignition switch	Battery voltage	
43 (G)	Ground	ECM relay power supply	Output	Ignition switch OFF (More than a few seconds after turning ignition switch OFF)	0 V	EXL	
				<ul style="list-style-type: none"> • Ignition switch ON • Ignition switch OFF (For a few seconds after turning ignition switch OFF) 	Battery voltage	M	
44 (P)	Ground	ECM relay power supply	Output	Ignition switch OFF (More than a few seconds after turning ignition switch OFF)	0 V	N	
				<ul style="list-style-type: none"> • Ignition switch ON • Ignition switch OFF (For a few seconds after turning ignition switch OFF) 	Battery voltage	O	
45 (Y)	Ground	TCM power supply	Output	Ignition switch OFF	Battery voltage	P	
46 (O)	Ground	Front wiper LO	Output	Ignition switch ON	Front wiper switch OFF	0 V	
					Front wiper switch LO	Battery voltage	

IPDM E/R (INTELLIGENT POWER DISTRIBUTION MODULE ENGINE ROOM)

< ECU DIAGNOSIS INFORMATION >

Terminal NO. (Wire color)		Description		Condition	Value (Approx.)	
		Signal name	Input/ Output			
+	-					
47 (BR)	Ground	Transmission range switch*2	Input	Select lever in any position other than P or N (Ignition switch ON)		0 V
				Select lever P or N (Ignition switch ON)		Battery voltage
		Clutch interlockk switch*3		Release the clutch pedal		0 V
				Depress the clutch pedal		Battery voltage
49 (W)	Ground	Headlamp HI (RH)	Output	Ignition switch ON	Lighting switch OFF	0 V
					<ul style="list-style-type: none"> • Lighting switch HI • Lighting switch PASS 	
				Daytime running light activated*1		7.0 V
50 (GR)	Ground	Headlamp HI (LH)	Output	Ignition switch ON	Lighting switch OFF	0 V
					<ul style="list-style-type: none"> • Lighting switch HI • Lighting switch PASS 	
				Daytime running light activated*1		7.0 V
51 (R)	Ground	Headlamp LO (LH)	Output	Ignition switch ON	Lighting switch OFF	0 V
					Lighting switch 2ND	
52 (P)	Ground	Headlamp LO (RH)	Output	Ignition switch ON	Lighting switch OFF	0 V
		Daytime running light relay-2*1			Lighting switch 2ND	
54 (GR)	Ground	Throttle control motor relay power supply	Output	Ignition switch OFF (More than a few seconds after turning ignition switch OFF)		0 V
				<ul style="list-style-type: none"> • Ignition switch ON • Ignition switch OFF (For a few seconds after turning ig- nition switch OFF) 		Battery voltage
55 (P)	Ground	Fuel pump power sup- ply	Output	Approximately 1 second or more than after turning the ignition switch ON		0 V
				<ul style="list-style-type: none"> • Approximately 1 second after turn- ing the ignition switch ON • Engine running 		Battery voltage
56 (SB)	Ground	A/C relay power supply	Output	Engine running	A/C switch OFF	0 V
					A/C switch ON (A/C compressor is oper- ating)	
57 (G)	Ground	Throttle control motor relay control	Output	Ignition switch ON → OFF		0 - 1.0 V ↓ Battery voltage ↓ 0 V
				Ignition switch ON		0 - 1.0 V
58 (R)*2 (Y)*3	Ground	Ignition relay power supply	Output	Ignition switch OFF		0 V
				Ignition switch ON		Battery voltage
59 (Y)	Ground	Ignition relay power supply	Output	Ignition switch OFF		0 V
				Ignition switch ON		Battery voltage
60 (V)	Ground	Ignition relay power supply	Output	Ignition switch OFF		0 V
				Ignition switch ON		Battery voltage

IPDM E/R (INTELLIGENT POWER DISTRIBUTION MODULE ENGINE ROOM)

< ECU DIAGNOSIS INFORMATION >

Terminal NO. (Wire color)		Description		Condition		Value (Approx.)
+	-	Signal name	Input/ Output			
61 (W)	Ground	Ignition relay power supply	Output	Ignition switch OFF		0 V
				Ignition switch ON		Battery voltage
62 (L)	Ground	Ignition relay power supply	Output	Ignition switch OFF		0 V
				Ignition switch ON		Battery voltage
64*2 (R)	Ground	CVT shift selector (Detention switch)	Input	Ignition switch ON	Select lever P	0 V
					Select lever in any position other than P	Battery voltage
65 (Y)	Ground	Steering lock unit condition-1	Input	Steering lock is activated		0 V
				Steering lock is deactivated		Battery voltage
66 (L)	Ground	Push-button ignition switch	Input	Press the push-button ignition switch		0 V
				Release the push-button ignition switch		Battery voltage
68 (W)	Ground	Steering lock unit condition-2	Input	Steering lock is activated		Battery voltage
				Steering lock is deactivated		0 V
69 (O)	Ground	Ignition relay monitor	Input	Ignition switch OFF or ACC		Battery voltage
				Ignition switch ON		0 V

*1: With daytime running light system

*2: CVT models

*3: M/T models

A
B
C
D
E
F
G
H
I
J
K
L
M
N
O
P

EXL

IPDM E/R (INTELLIGENT POWER DISTRIBUTION MODULE ENGINE ROOM)

< ECU DIAGNOSIS INFORMATION >

WITH INTELLIGENT KEY : Wiring Diagram — IPDM E/R —

INFOID:000000005189744

IPDM E/R (INTELLIGENT POWER DISTRIBUTION MODULE ENGINE ROOM) (WITH INTELLIGENT KEY)

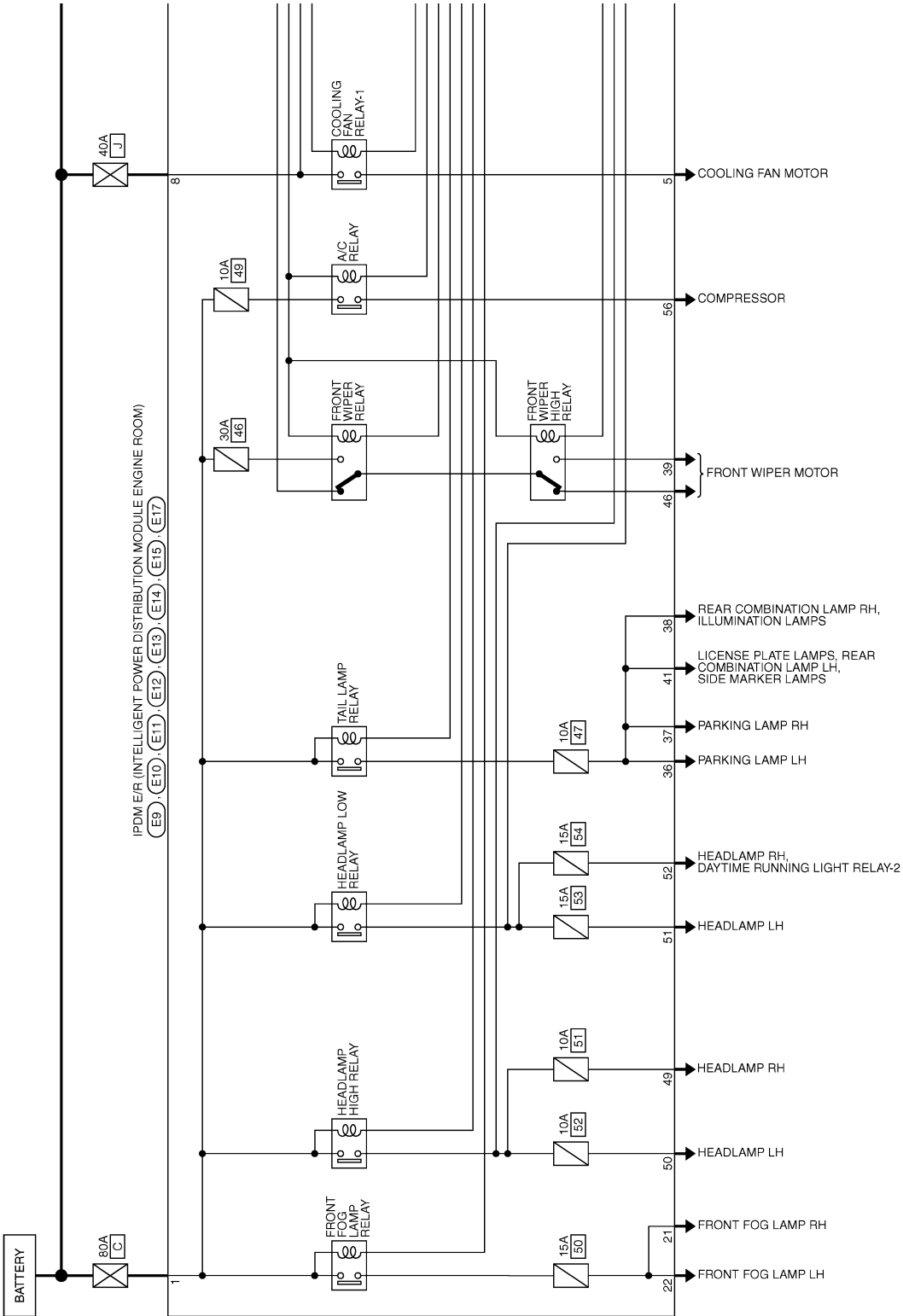

2009/02/27

JCMWM4080GB

IPDM E/R (INTELLIGENT POWER DISTRIBUTION MODULE ENGINE ROOM)

< ECU DIAGNOSIS INFORMATION >

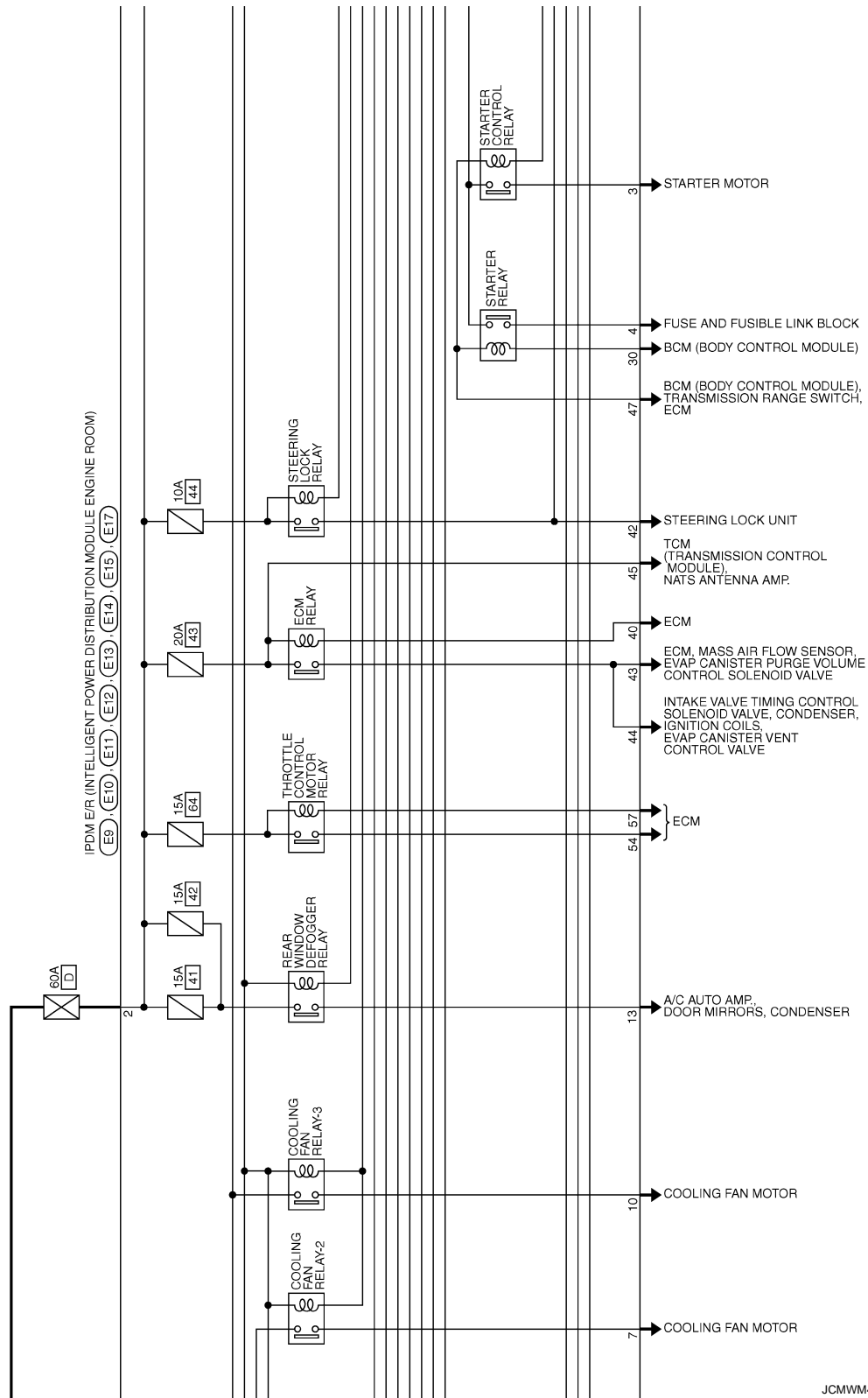

JCMWM4081GB

A
B
C
D
E
F
G
H
I
J
K
L
M
N
O
P

EXL

IPDM E/R (INTELLIGENT POWER DISTRIBUTION MODULE ENGINE ROOM)

< ECU DIAGNOSIS INFORMATION >

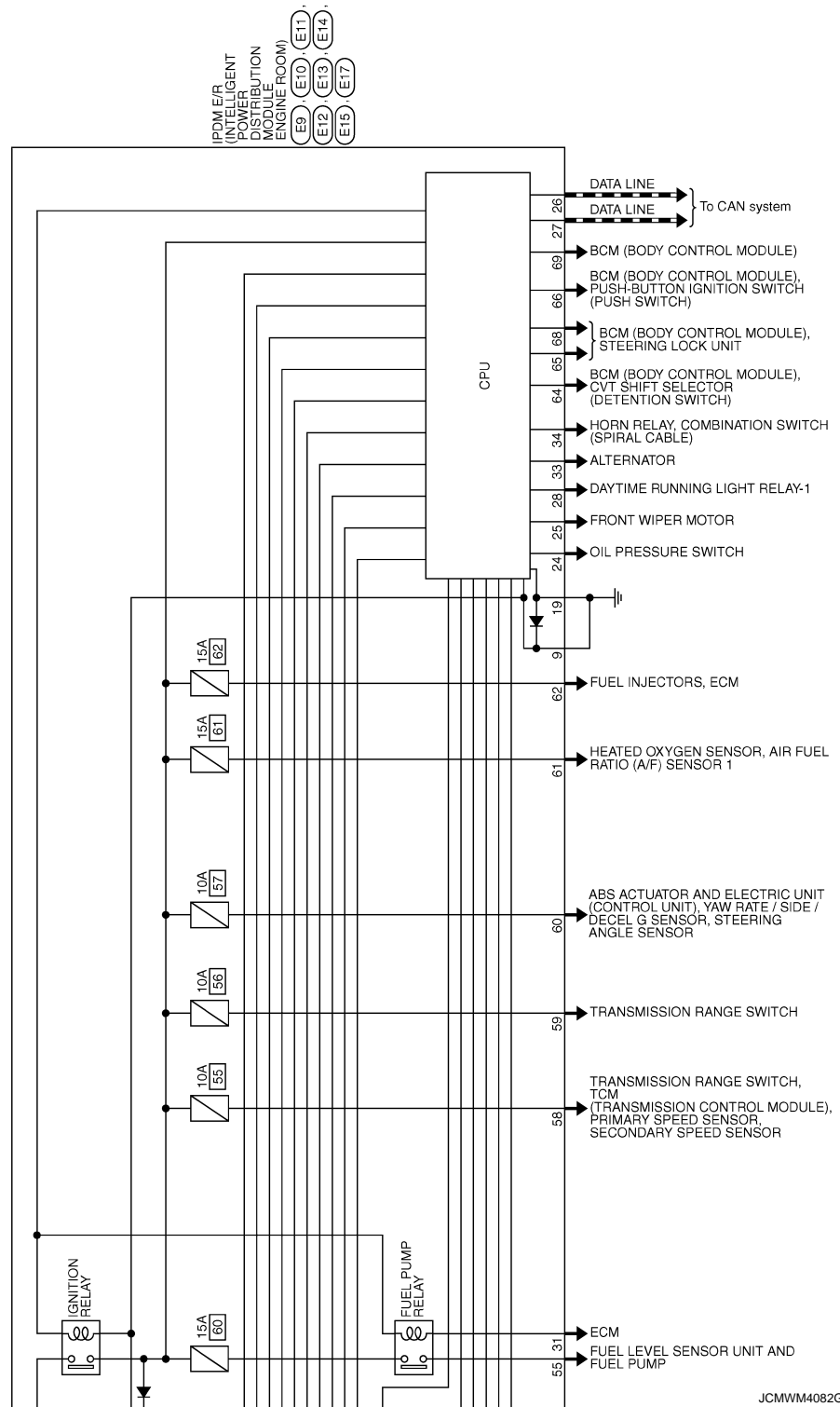

IPDM E/R (INTELLIGENT POWER DISTRIBUTION MODULE ENGINE ROOM)

< ECU DIAGNOSIS INFORMATION >

IPDM E/R (INTELLIGENT POWER DISTRIBUTION MODULE ENGINE ROOM) (WITH INTELLIGENT KEY)

Connector No.	E12
Connector Name	IPDM E/R (INTELLIGENT POWER DISTRIBUTION MODULE ENGINE ROOM)
Connector Type	NS33FBR-CS



22	21	19	18
----	----	----	----

Terminal No.	Color of Wire	Signal Name [Specification]
19	B/W	-
21	W	-
22	V	-

Connector No.	E11
Connector Name	IPDM E/R (INTELLIGENT POWER DISTRIBUTION MODULE ENGINE ROOM)
Connector Type	MSDFE-LC



10	9
13	

Terminal No.	Color of Wire	Signal Name [Specification]
9	B/W	-
10	L	-
13	W	-

Connector No.	E10
Connector Name	IPDM E/R (INTELLIGENT POWER DISTRIBUTION MODULE ENGINE ROOM)
Connector Type	MSDFW-LC



5	4	3
8	7	6

Terminal No.	Color of Wire	Signal Name [Specification]
3	BR	-
4	P	-
5	LG	-
7	Y	-
8	V	-

Connector No.	E9
Connector Name	IPDM E/R (INTELLIGENT POWER DISTRIBUTION MODULE ENGINE ROOM)
Connector Type	LOPE-MC



1	2
---	---

Terminal No.	Color of Wire	Signal Name [Specification]
1	R	-
2	G	-

Connector No.	E15
Connector Name	IPDM E/R (INTELLIGENT POWER DISTRIBUTION MODULE ENGINE ROOM)
Connector Type	NS18FW-CS



52	51	50	49	47				
62	61	60	59	58	57	56	55	54

Terminal No.	Color of Wire	Signal Name [Specification]
60	V	-
61	W	-
62	L	-

Connector No.	E14
Connector Name	IPDM E/R (INTELLIGENT POWER DISTRIBUTION MODULE ENGINE ROOM)
Connector Type	NS12FBR-CS



39	38	37	36			
46	45	44	43	42	41	40

Connector No.	E13
Connector Name	IPDM E/R (INTELLIGENT POWER DISTRIBUTION MODULE ENGINE ROOM)
Connector Type	TH12FW-NH



28	27	26	25	24
34	33	31	30	

Terminal No.	Color of Wire	Signal Name [Specification]
36	O	-
37	V	-
38	G	-
39	V	-
40	R	-
41	SB	-
42	W	-
43	G	-
44	P	-
45	Y	-
46	O	-

Terminal No.	Color of Wire	Signal Name [Specification]
24	G	-
25	Y	-
26	P	-
27	L	-
28	P	-
30	SB	-
31	W	-
33	O	-
34	R	-

Terminal No.	Color of Wire	Signal Name [Specification]
47	BR	-
49	W	-
50	GR	-
51	R	-
52	P	-
54	GR	-
55	P	-
56	SB	-
57	G	-
58	R	-
59	Y	-

Terminal No.	Color of Wire	Signal Name [Specification]
36	O	-
37	V	-
38	G	-
39	V	-
40	R	-
41	SB	-
42	W	-
43	G	-
44	P	-
45	Y	-
46	O	-

Terminal No.	Color of Wire	Signal Name [Specification]
24	G	-
25	Y	-
26	P	-
27	L	-
28	P	-
30	SB	-
31	W	-
33	O	-
34	R	-

JCMWM4083GB

A
B
C
D
E
F
G
H
I
J
K
L
M
N
O
P

EXL

IPDM E/R (INTELLIGENT POWER DISTRIBUTION MODULE ENGINE ROOM) (WITH INTELLIGENT KEY)

Connector No.	E17
Connector Name	IPDM E/R (INTELLIGENT POWER DISTRIBUTION MODULE ENGINE ROOM)
Connector Type	TH10FB-NH

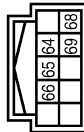

Terminal No.	Color of Wire	Signal Name [Specification]
64	R	-
65	Y	-
66	L	-
68	W	-
68	O	-

JCMWM4084GB

INFOID:000000005189745

WITH INTELLIGENT KEY : Fail-Safe

CAN COMMUNICATION CONTROL

When CAN communication with ECM and BCM is impossible, IPDM E/R performs fail-safe control. After CAN communication recovers normally, it also returns to normal control.

If No CAN Communication Is Available With ECM

IPDM E/R (INTELLIGENT POWER DISTRIBUTION MODULE ENGINE ROOM)

< ECU DIAGNOSIS INFORMATION >

Control part	Fail-safe operation
Cooling fan	<ul style="list-style-type: none"> The cooling fan relay-1, the cooling fan relay-2 and the cooling fan relay-3 turn ON when the ignition switch is turned ON (Cooling fan HI operation) The cooling fan relay-1, the cooling fan relay-2 and the cooling fan relay-3 turn OFF when the ignition switch is turned OFF
A/C compressor	A/C relay OFF
Alternator	Outputs the power generation command signal (PWM signal) 0%

If No CAN Communication Is Available With BCM

Control part	Fail-safe operation
Headlamp	<ul style="list-style-type: none"> Turns ON the headlamp low relay when the ignition switch is turned ON Turns OFF the headlamp low relay when the ignition switch is turned OFF Headlamp high relay OFF Daytime running light relay OFF*
<ul style="list-style-type: none"> Parking lamps Side marker lamps License plate lamps Illuminations Tail lamps 	<ul style="list-style-type: none"> Turns ON the tail lamp relay when the ignition switch is turned ON Turns OFF the tail lamp relay when the ignition switch is turned OFF
Front wiper	<ul style="list-style-type: none"> The status just before activation of fail-safe control is maintained until the ignition switch is turned OFF while the front wiper is operating at LO or HI speed. The wiper is operated at LO speed until the ignition switch is turned OFF if the fail-safe control is activated while the front wiper is set in the INT mode and the front wiper motor is operating.
Front fog lamps	Front fog lamp relay OFF
Horn	Horn OFF
Ignition relay	The status just before activation of fail-safe is maintained.
Starter motor	Starter control relay OFF
Steering lock unit	Steering lock relay OFF

*: With daytime running light system

IGNITION RELAY MALFUNCTION DETECTION FUNCTION

- IPDM E/R monitors the voltage at the contact circuit and excitation coil circuit of the ignition relay inside it.
- IPDM E/R judges the ignition relay error if the voltage differs between the contact circuit and the excitation coil circuit.
- If the ignition relay cannot turn OFF due to contact seizure, it activates the tail lamp relay for 10 minutes to alert the user to the ignition relay malfunction when the ignition switch is turned OFF.

Voltage judgment		IPDM E/R judgment	Operation
Ignition relay contact side	Ignition relay excitation coil side		
ON	ON	Ignition relay ON normal	—
OFF	OFF	Ignition relay OFF normal	—
ON	OFF	Ignition relay ON stuck	<ul style="list-style-type: none"> Detects DTC "B2098: IGN RELAY ON" Turns ON the tail lamp relay for 10 minutes
OFF	ON	Ignition relay OFF stuck	Detects DTC "B2099: IGN RELAY OFF"

FRONT WIPER CONTROL

IPDM E/R detects front wiper stop position by a front wiper stop position signal. When a front wiper stop position signal is in the conditions listed below, IPDM E/R stops power supply to wiper after repeating a front wiper 10 seconds activation and 20 seconds stop five times.

IPDM E/R (INTELLIGENT POWER DISTRIBUTION MODULE ENGINE ROOM)

< ECU DIAGNOSIS INFORMATION >

Ignition switch	Front wiper switch	Front wiper stop position signal
ON	OFF	The front wiper stop position signal (stop position) cannot be input for 10 seconds.
	ON	The front wiper stop position signal does not change for 10 seconds.

NOTE:

This operation status can be confirmed on the IPDM E/R “Data Monitor” that displays “BLOCK” for the item “WIP PROT” while the wiper is stopped.

STARTER MOTOR PROTECTION FUNCTION

IPDM E/R turns OFF the starter control relay to protect the starter motor when the starter control relay remains active for 90 seconds.

WITH INTELLIGENT KEY : DTC Index

INFOID:000000005189746

NOTE:

- The details of time display are as follows.
 - CRNT: A malfunction is detected now.
 - PAST: A malfunction was detected in the past.
- IGN counter is displayed on FFD (Freeze Frame data).
 - The number is 0 when is detected now.
 - The number increases like 1 → 2 ... 38 → 39 after returning to the normal condition whenever IGN OFF → ON.
 - The number is fixed to 39 until the self-diagnosis results are erased if it is over 39.

×: Applicable

CONSULT display	Fail-safe	Refer to
No DTC is detected. further testing may be required.	—	—
U1000: CAN COMM CIRCUIT	×	PCS-16
B2098: IGN RELAY ON	×	PCS-17
B2099: IGN RELAY OFF	—	PCS-18
B2108: STRG LCK RELAY ON	—	SEC-96
B2109: STRG LCK RELAY OFF	—	SEC-97
B210A: STRG LCK STATE SW	—	SEC-98
B210B: START CONT RLY ON	—	SEC-101
B210C: START CONT RLY OFF	—	SEC-102
B210D: STARTER RELAY ON	—	SEC-103
B210E: STARTER RELAY OFF	—	SEC-104
B210F: INTRLCK/PNP SW ON	—	SEC-106
B2110: INTRLCK/PNP SW OFF	—	SEC-108

WITHOUT INTELLIGENT KEY

WITHOUT INTELLIGENT KEY : Reference Value

INFOID:000000005189747

VALUES ON THE DIAGNOSIS TOOL

Monitor Item	Condition		Value/Status
MOTOR FAN REQ	Engine idle speed	Changes depending on engine coolant temperature, air conditioner operation status, vehicle speed, etc.	1/2/3/4

IPDM E/R (INTELLIGENT POWER DISTRIBUTION MODULE ENGINE ROOM)

< ECU DIAGNOSIS INFORMATION >

Monitor Item	Condition		Value/Status
AC COMP REQ	Engine running	A/C switch OFF	Off
		A/C switch ON (Compressor is operating)	On
TAIL&CLR REQ	Lighting switch OFF		Off
	Lighting switch 1ST, 2ND, HI or AUTO (Light is illuminated)		On
HL LO REQ	Lighting switch OFF		Off
	Lighting switch 2ND, HI or AUTO (Light is illuminated)		On
HL HI REQ	Lighting switch OFF		Off
	Lighting switch HI		On
FR FOG REQ	Lighting switch 2ND or AUTO (Light is illuminated)	Front fog lamp switch OFF	Off
		Front fog lamp switch ON	On
FR WIP REQ	Ignition switch ON	Front wiper switch OFF	Stop
		Front wiper switch INT	1LOW
		Front wiper switch LO	Low
		Front wiper switch HI	Hi
WIP AUTO STOP	Ignition switch ON	Front wiper stop position	STOP P
		Any position other than front wiper stop position	ACT P
WIP PROT	Ignition switch ON	Front wiper operates normally	Off
		Front wiper stops at fail-safe opera- tion	BLOCK
IGN RLY	Ignition switch OFF or ACC		Off
	Ignition switch ON		On
INTER/NP SW	Ignition switch ON	Selector lever in any position other than P or N (CVT models)	Off
		Selector lever in P or N position (CVT models)	On
ST RLY -REQ	Ignition switch OFF or ACC		Off
	Ignition switch ON		On
DTRL REQ NOTE: This item is monitored only on the vehicle with the daytime running light system.	Not operation		Off
	Daytime running light system is operated.		On
OIL P SW	Ignition switch OFF, ACC or engine running		Open
	Ignition switch ON		Close
HOOD SW	NOTE: The item is indicated, but not monitored.		Off
THFT HRN REQ	Not operation		Off
	<ul style="list-style-type: none"> Panic alarm is activated Horn is activated with VEHICLE SECURITY (THEFT WARNING) SYS- TEM 		On
HORN CHIRP	Not operating		Off
	Door locking with key fob (horn chirp mode)		On

A
B
C
D
E
F
G
H
I
J
K
EXL
M
N
O
P

IPDM E/R (INTELLIGENT POWER DISTRIBUTION MODULE ENGINE ROOM)

< ECU DIAGNOSIS INFORMATION >

TERMINAL LAYOUT

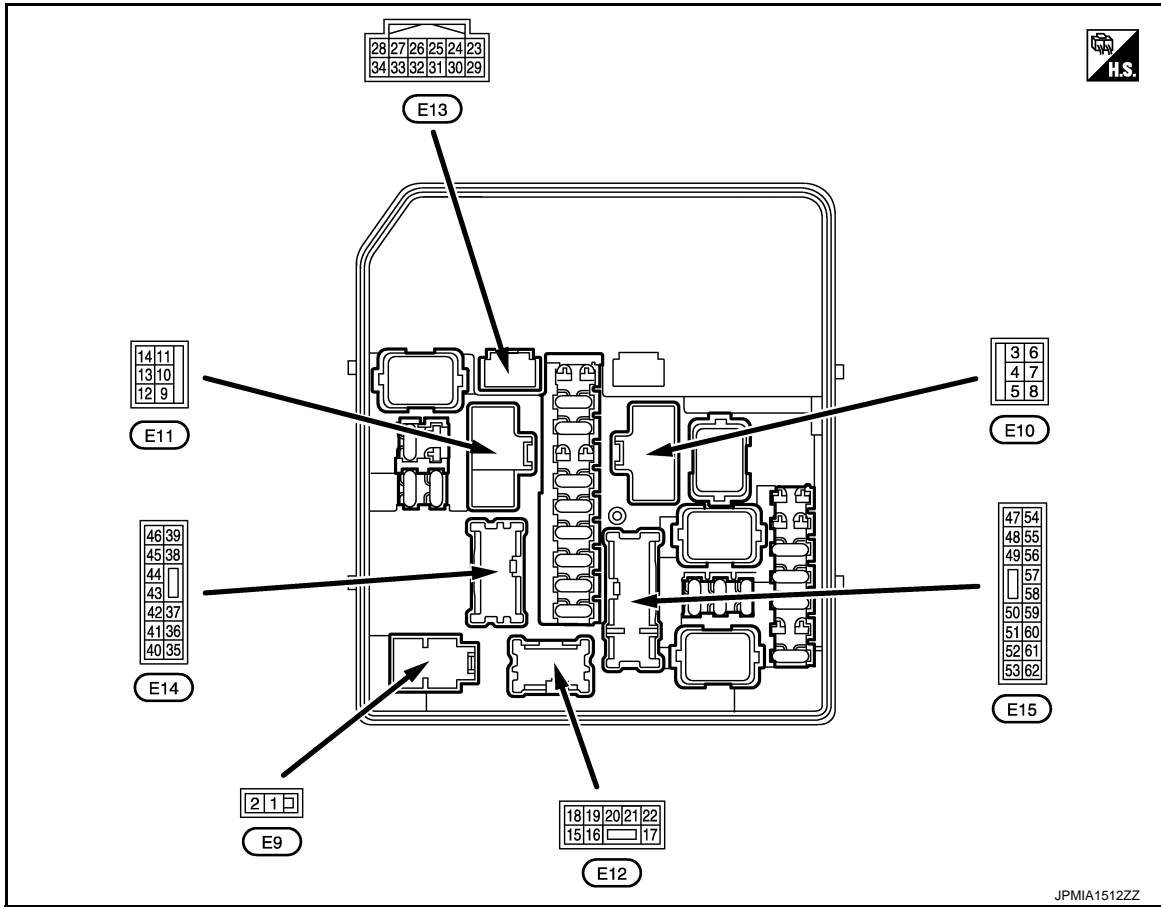

PHYSICAL VALUES

Terminal NO. (Wire color)		Description		Condition	Value (Approx.)
+	-	Signal name	Input/ Output		
1 (R)	Ground	Battery power supply	Input	Ignition switch OFF	Battery voltage
2 (G)	Ground	Battery power supply	Input	Ignition switch OFF	Battery voltage
3 (BR)	Ground	Starter motor	Output	Ignition switch ON	0 V
				At engine cranking	Battery voltage
5 (LG)	Ground	Cooling fan relay-1 power supply	Output	Cooling fan OFF	0 V
				Cooling fan operated	Battery voltage
6 (SB)	Ground	Ignition switch START	Output	Any position other ignition switch START	0 V
				Ignition switch START	Battery voltage
7 (Y)	Ground	Cooling fan relay-2 power supply	Output	Cooling fan OFF	0 V
				Cooling fan LO operated	9.0 V
				Cooling fan HI operated	Battery voltage
8 (V)	Ground	Battery power supply	Input	Ignition switch OFF	Battery voltage
9 (B/W)	Ground	Ground	—	Ignition switch ON	0 V

IPDM E/R (INTELLIGENT POWER DISTRIBUTION MODULE ENGINE ROOM)

< ECU DIAGNOSIS INFORMATION >

Terminal NO. (Wire color)		Description		Condition		Value (Approx.)
+	-	Signal name	Input/ Output			
10 (L)	Ground	Cooling fan motor ground	Output	Cooling fan OFF		0 V
				Cooling fan LO operated		5.0 V
				Cooling fan HI operated		0 V
13 (W)	Ground	Rear window defogger	Output	Ignition switch OFF	Rear window defogger switch OFF	0 V
				ON	Rear window defogger switch ON	Battery voltage
18 (Y)	Ground	Ignition switch	Output	Ignition switch OFF		0 V
				Ignition switch ON		Battery voltage
19 (B/W)	Ground	Ground	—	Ignition switch ON		0 V
21 (W)	Ground	Front fog lamp (RH)	Output	Lighting switch 2ND	Front fog lamp switch OFF	0 V
					Front fog lamp switch ON	Battery voltage
22 (V)	Ground	Front fog lamp (LH)	Output	Lighting switch 2ND	Front fog lamp switch OFF	0 V
					Front fog lamp switch ON	Battery voltage
24 (G)	Ground	Oil pressure switch	Input	Ignition switch ON	Engine stopped	0 V
					Engine running	Battery voltage
25 (Y)	Ground	Front wiper auto stop	Input	Ignition switch ON	Front wiper stop position	0 V
					Any position other than front wiper stop position	Battery voltage
26 (P)	Ground	CAN-L	Input/ Output	—		—
27 (L)	Ground	CAN-H	Input/ Output	—		—
28*1 (P)	Ground	Daytime running light relay-1 control	Output	Daytime running light deactivated		0 V
				Daytime running light activated		Battery voltage
31 (W)	Ground	Fuel pump relay control	Output	<ul style="list-style-type: none"> Approximately 1 second after turning the ignition switch ON Engine running 		0 - 1.5 V
				Approximately 1 second or more after turning the ignition switch ON		Battery voltage

A
B
C
D
E
F
G
H
I
J
K
EXL
M
N
O
P

IPDM E/R (INTELLIGENT POWER DISTRIBUTION MODULE ENGINE ROOM)

< ECU DIAGNOSIS INFORMATION >

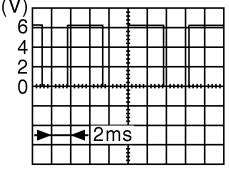
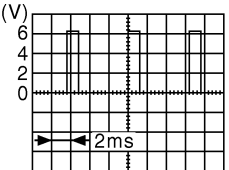
Terminal NO. (Wire color)		Description		Condition	Value (Approx.)	
+	-	Signal name	Input/ Output			
33 (O)	Ground	Power generation command signal	Output	Ignition switch ON	Battery voltage	
				40 % is set on "ACTIVE TEST", "ALTERNATOR DUTY" of "ENGINE"	 <p style="text-align: right;">JPMIA0002GB</p>	3.8 V
				80 % is set on "ACTIVE TEST", "ALTERNATOR DUTY" of "ENGINE"	 <p style="text-align: right;">JPMIA0003GB</p>	1.4 V
34 (R)	Ground	Horn relay control	Output	The horn is deactivated	Battery voltage	
				The horn is activated	0 V	
36 (O)	Ground	Parking lamp (LH)	Output	Ignition switch OFF	Lighting switch OFF	0 V
				Ignition switch ON	Lighting switch 1ST	Battery voltage
37 (V)	Ground	Parking lamp (RH)	Output	Ignition switch OFF	Lighting switch OFF	0 V
				Ignition switch ON	Lighting switch 1ST	Battery voltage
38 (G)	Ground	Tail lamp (RH) & illuminations	Output	Ignition switch OFF	Lighting switch OFF	0 V
				Ignition switch ON	Lighting switch 1ST	Battery voltage
39 (V)	Ground	Front wiper HI	Output	Ignition switch OFF	Front wiper switch OFF	0 V
				Ignition switch ON	Front wiper switch HI	Battery voltage
40 (R)	Ground	ECM relay control	Output	Ignition switch OFF (More than a few seconds after turning ignition switch OFF)	Battery voltage	
				<ul style="list-style-type: none"> Ignition switch ON Ignition switch OFF (For a few seconds after turning ignition switch OFF) 	0 - 1.5 V	
41 (SB)	Ground	Tail lamp (LH) & license plate lamps	Output	Ignition switch OFF	Lighting switch OFF	0 V
				Ignition switch ON	Lighting switch 1ST	Battery voltage
43 (G)	Ground	ECM relay power supply	Output	Ignition switch OFF (More than a few seconds after turning ignition switch OFF)	0 V	
				<ul style="list-style-type: none"> Ignition switch ON Ignition switch OFF (For a few seconds after turning ignition switch OFF) 	Battery voltage	

IPDM E/R (INTELLIGENT POWER DISTRIBUTION MODULE ENGINE ROOM)

< ECU DIAGNOSIS INFORMATION >

Terminal NO. (Wire color)		Description		Condition		Value (Approx.)		
+	-	Signal name	Input/ Output					
44 (P)	Ground	ECM relay power supply	Output	Ignition switch OFF (More than a few seconds after turning ignition switch OFF)		0 V	A	
				<ul style="list-style-type: none"> Ignition switch ON Ignition switch OFF (For a few seconds after turning ignition switch OFF) 		Battery voltage	B C	
45 (Y)	Ground	TCM power supply	Output	Ignition switch OFF		Battery voltage	D	
46 (O)	Ground	Front wiper LO	Output	Ignition switch ON	Front wiper switch OFF	0 V	E	
					Front wiper switch LO	Battery voltage		
47 (BR)	Ground	Transmission range switch ^{*2}	Input	Select lever in any position other than P or N (Ignition switch ON)		0 V	F	
				Select lever P or N (Ignition switch ON)		Battery voltage	G	
		Clutch interlock switch ^{*3}	Input	Release the clutch pedal		0 V	G	
				Depress the clutch pedal		Battery voltage		
49 (W)	Ground	Headlamp HI (RH)	Output	Ignition switch ON	Lighting switch OFF	0 V	H	
					<ul style="list-style-type: none"> Lighting switch HI Lighting switch PASS 			Battery voltage
					Daytime running light activated ^{*1}			7.0 V
50 (GR)	Ground	Headlamp HI (LH)	Output	Ignition switch ON	Lighting switch OFF	0 V	I	
					<ul style="list-style-type: none"> Lighting switch HI Lighting switch PASS 			Battery voltage
					Daytime running light activated ^{*1}			7.0 V
51 (R)	Ground	Headlamp LO (LH)	Output	Ignition switch ON	Lighting switch OFF	0 V	K	
					Lighting switch 2ND			Battery voltage
52 (P)	Ground	Headlamp LO (RH)	Output	Ignition switch ON	Lighting switch OFF	0 V	EXL	
		Daytime running light relay-2 ^{*1}			Lighting switch 2ND	Battery voltage		
54 (GR)	Ground	Throttle control motor relay power supply	Output	Ignition switch OFF (More than a few seconds after turning ignition switch OFF)		0 V	M	
				<ul style="list-style-type: none"> Ignition switch ON Ignition switch OFF (For a few seconds after turning ignition switch OFF) 		Battery voltage	N	
55 (P)	Ground	Fuel pump power supply	Output	Approximately 1 second or more than after turning the ignition switch ON		0 V	O	
				<ul style="list-style-type: none"> Approximately 1 second after turning the ignition switch ON Engine running 		Battery voltage	P	
56 (SB)	Ground	A/C relay power supply	Output	Engine running	A/C switch OFF	0 V		
					A/C switch ON (A/C compressor is operating)			Battery voltage

IPDM E/R (INTELLIGENT POWER DISTRIBUTION MODULE ENGINE ROOM)

< ECU DIAGNOSIS INFORMATION >

Terminal NO. (Wire color)		Description		Condition	Value (Approx.)
+	-	Signal name	Input/ Output		
57 (G)	Ground	Throttle control motor relay control	Output	Ignition switch ON → OFF	0 - 1.0 V ↓ Battery voltage ↓ 0 V
				Ignition switch ON	0 - 1.0 V
58 (R) ^{*2} (Y) ^{*3}	Ground	Ignition relay power supply	Output	Ignition switch OFF	0 V
				Ignition switch ON	Battery voltage
59 (Y)	Ground	Ignition relay power supply	Output	Ignition switch OFF	0 V
				Ignition switch ON	Battery voltage
60 (V)	Ground	Ignition relay power supply	Output	Ignition switch OFF	0 V
				Ignition switch ON	Battery voltage
61 (W)	Ground	Ignition relay power supply	Output	Ignition switch OFF	0 V
				Ignition switch ON	Battery voltage
62 (L)	Ground	Ignition relay power supply	Output	Ignition switch OFF	0 V
				Ignition switch ON	Battery voltage

*1: With daytime running light system

*2: CVT models

*3: M/T models

IPDM E/R (INTELLIGENT POWER DISTRIBUTION MODULE ENGINE ROOM)

< ECU DIAGNOSIS INFORMATION >

WITHOUT INTELLIGENT KEY : Wiring Diagram — IPDM E/R —

INFOID:000000005189748

IPDM E/R (INTELLIGENT POWER DISTRIBUTION MODULE ENGINE ROOM) (WITHOUT INTELLIGENT KEY)

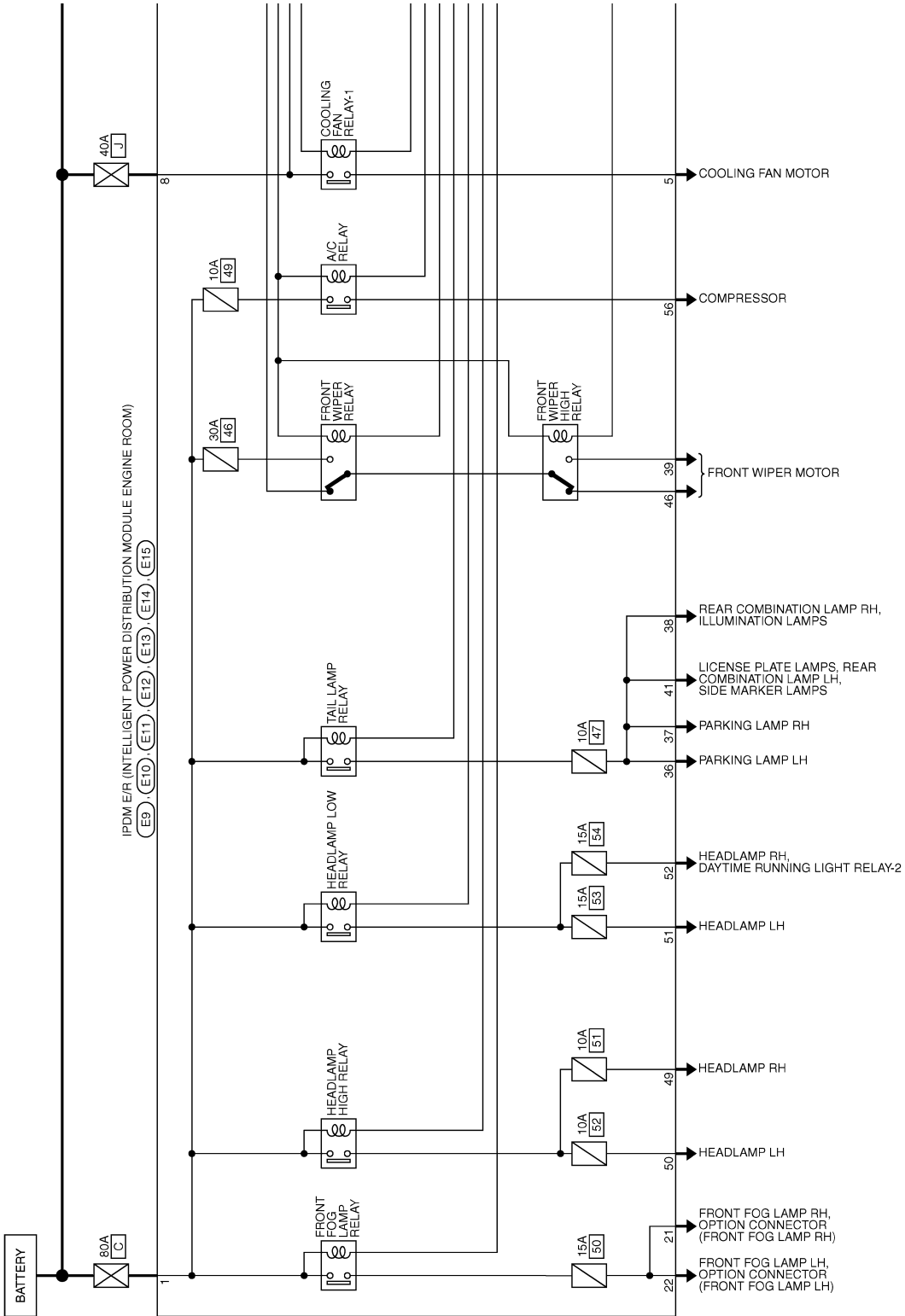

2009/02/27

JCMWM4085GB

A
B
C
D
E
F
G
H
I
J
K
L
M
N
O
P

EXL

IPDM E/R (INTELLIGENT POWER DISTRIBUTION MODULE ENGINE ROOM)

< ECU DIAGNOSIS INFORMATION >

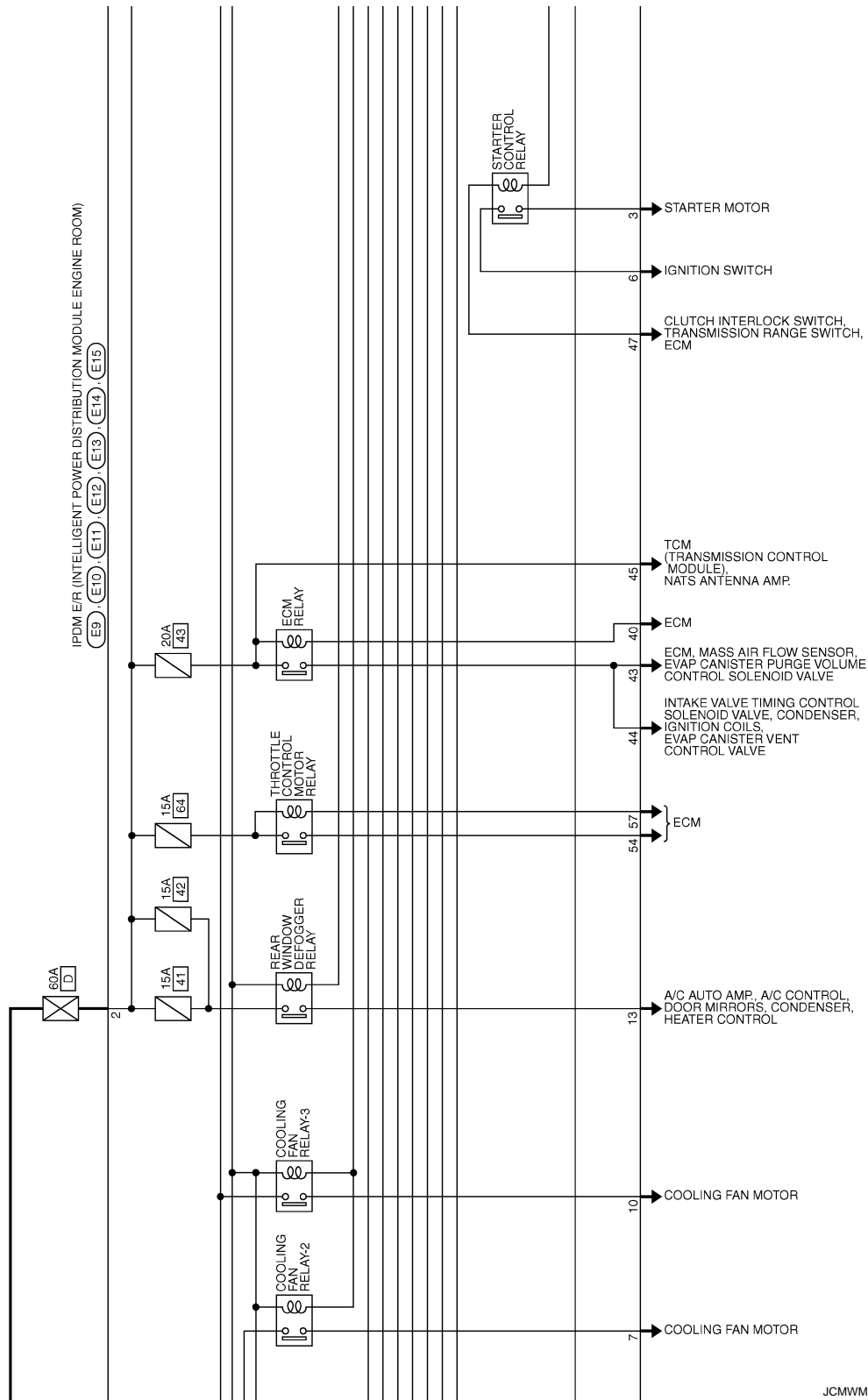

JCMWM4086GB

IPDM E/R (INTELLIGENT POWER DISTRIBUTION MODULE ENGINE ROOM)

< ECU DIAGNOSIS INFORMATION >

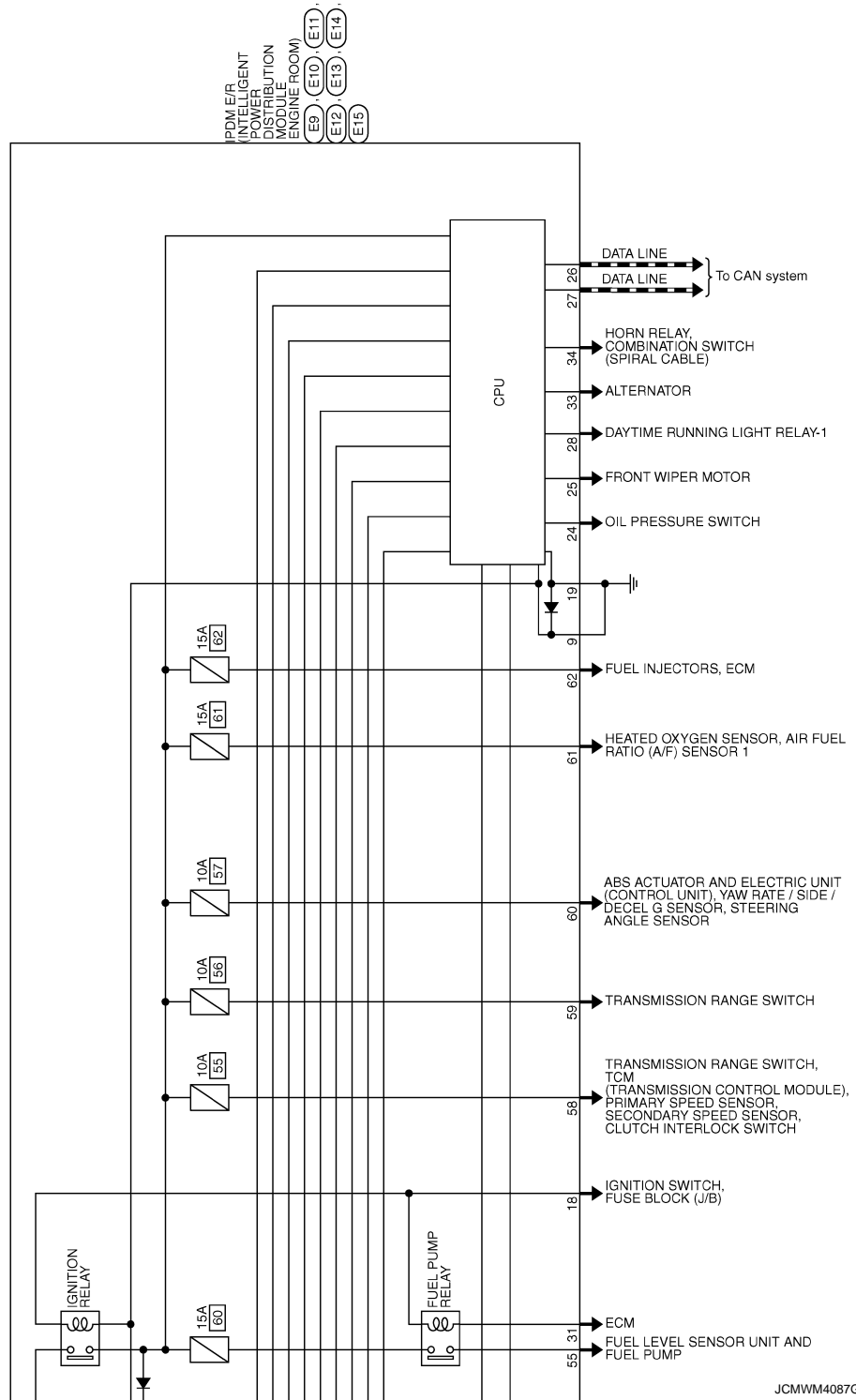

A
 B
 C
 D
 E
 F
 G
 H
 I
 J
 K
 EXL
 M
 N
 O
 P

IPDM E/R (INTELLIGENT POWER DISTRIBUTION MODULE ENGINE ROOM)

< ECU DIAGNOSIS INFORMATION >

IPDM E/R (INTELLIGENT POWER DISTRIBUTION MODULE ENGINE ROOM) (WITHOUT INTELLIGENT KEY)			IPDM E/R (INTELLIGENT POWER DISTRIBUTION MODULE ENGINE ROOM)			IPDM E/R (INTELLIGENT POWER DISTRIBUTION MODULE ENGINE ROOM)			IPDM E/R (INTELLIGENT POWER DISTRIBUTION MODULE ENGINE ROOM)			IPDM E/R (INTELLIGENT POWER DISTRIBUTION MODULE ENGINE ROOM)			IPDM E/R (INTELLIGENT POWER DISTRIBUTION MODULE ENGINE ROOM)																													
Connector No.	Connector Name	Connector Type	Terminal No.	Color of Wire	Signal Name [Specification]	Terminal No.	Color of Wire	Signal Name [Specification]	Terminal No.	Color of Wire	Signal Name [Specification]	Terminal No.	Color of Wire	Signal Name [Specification]	Terminal No.	Color of Wire	Signal Name [Specification]																											
E9	IPDM E/R (INTELLIGENT POWER DISTRIBUTION MODULE ENGINE ROOM)	LS2FB-MC	1	R	-	9	B/W	-	E10	IPDM E/R (INTELLIGENT POWER DISTRIBUTION MODULE ENGINE ROOM)	MOBEV-LC	5	LG	-	E11	IPDM E/R (INTELLIGENT POWER DISTRIBUTION MODULE ENGINE ROOM)	MOBEF-LC	10	L	-	E12	IPDM E/R (INTELLIGENT POWER DISTRIBUTION MODULE ENGINE ROOM)	NS30FBF-GS	18	Y	-	E13	IPDM E/R (INTELLIGENT POWER DISTRIBUTION MODULE ENGINE ROOM)	TH12FV-NH	24	G	-	E14	IPDM E/R (INTELLIGENT POWER DISTRIBUTION MODULE ENGINE ROOM)	NS12FBR-GS	39	O	-	E15	IPDM E/R (INTELLIGENT POWER DISTRIBUTION MODULE ENGINE ROOM)	NS18FW-GS	59	Y	-
2	G	-	5	LG	-	6	SB	-	8	Y	-	7	Y	-	3	BR	-	5	LG	-	19	B/W	-	60	V	-	37	V	-	61	W	-												
			6	SB	-	7	Y	-	8	Y	-	8	Y	-	38	G	-	39	O	-	13	W	-	40	R	-	43	G	-	44	P	-	62	L	-									
			7	Y	-	8	Y	-	8	Y	-	8	Y	-	45	Y	-	46	O	-	13	W	-	56	SB	-	57	G	-	58	Y	-	58	R	-	58	R	-						

WITHOUT INTELLIGENT KEY : Fail-Safe

CAN COMMUNICATION CONTROL

When CAN communication with ECM and BCM is impossible, IPDM E/R performs fail-safe control. After CAN communication recovers normally, it also returns to normal control.

If No CAN Communication Is Available With ECM

JCMWM4088GB

INFOID:000000005189749

IPDM E/R (INTELLIGENT POWER DISTRIBUTION MODULE ENGINE ROOM)

< ECU DIAGNOSIS INFORMATION >

Control part	Fail-safe operation
Cooling fan	<ul style="list-style-type: none"> The cooling fan relay-1, the cooling fan relay-2 and the cooling fan relay-3 turn ON when the ignition switch is turned ON (Cooling fan HI operation) The cooling fan relay-1, the cooling fan relay-2 and the cooling fan relay-3 turn OFF when the ignition switch is turned OFF
A/C compressor	A/C relay OFF
Alternator	Outputs the power generation command signal (PWM signal) 0%

If No CAN Communication Is Available With BCM

Control part	Fail-safe operation
Headlamp	<ul style="list-style-type: none"> Turns ON the headlamp low relay when the ignition switch is turned ON Turns OFF the headlamp low relay when the ignition switch is turned OFF Headlamp high relay OFF Daytime running light relay OFF*
<ul style="list-style-type: none"> Parking lamps Side marker lamps License plate lamps Illuminations Tail lamps 	<ul style="list-style-type: none"> Turns ON the tail lamp relay when the ignition switch is turned ON Turns OFF the tail lamp relay when the ignition switch is turned OFF
Front wiper	<ul style="list-style-type: none"> The status just before activation of fail-safe control is maintained until the ignition switch is turned OFF while the front wiper is operating at LO or HI speed. The wiper is operated at LO speed until the ignition switch is turned OFF if the fail-safe control is activated while the front wiper is set in the INT mode and the front wiper motor is operating.
Front fog lamps	Front fog lamp relay OFF
Rear window defogger relay	Rear window defogger relay OFF
Horn	Horn OFF

*: With daytime running light system

IGNITION RELAY MALFUNCTION DETECTION FUNCTION

- IPDM E/R monitors the voltage at the contact circuit of the ignition relay inside and ignition switch status from BCM via CAN communication.
- IPDM E/R judges the ignition relay error if the voltage differs between the contact circuit and the ignition switch status from BCM via CAN communication.
- If the ignition relay cannot turn OFF due to contact seizure, it activates the tail lamp relay for 10 minutes to alert the user to the ignition relay malfunction when the ignition switch is turned OFF.

Voltage judgment		IPDM E/R judgment	Operation
Ignition relay contact side	Ignition switch status from BCM		
ON	ON	Ignition relay ON normal	—
OFF	OFF	Ignition relay OFF normal	—
ON	OFF	Ignition relay ON stuck	<ul style="list-style-type: none"> Detects DTC "B2098: IGN RELAY ON" Turns ON the tail lamp relay for 10 minutes
OFF	ON	Ignition relay OFF stuck	Detects DTC "B2099: IGN RELAY OFF"

FRONT WIPER CONTROL

IPDM E/R detects front wiper stop position by a front wiper stop position signal. When a front wiper stop position signal is in the conditions listed below, IPDM E/R stops power supply to wiper after repeating a front wiper 10 seconds activation and 20 seconds stop five times.

IPDM E/R (INTELLIGENT POWER DISTRIBUTION MODULE ENGINE ROOM)

< ECU DIAGNOSIS INFORMATION >

Ignition switch	Front wiper switch	Front wiper stop position signal
ON	OFF	The front wiper stop position signal (stop position) cannot be input for 10 seconds.
	ON	The front wiper stop position signal does not change for 10 seconds.

NOTE:

This operation status can be confirmed on the IPDM E/R “Data Monitor” that displays “BLOCK” for the item “WIP PROT” while the wiper is stopped.

WITHOUT INTELLIGENT KEY : DTC Index

INFOID:000000005189750

NOTE:

- The details of time display are as follows.
 - CRNT: A malfunction is detected now.
 - PAST: A malfunction was detected in the past.
- IGN counter is displayed on FFD (Freeze Frame data).
 - The number is 0 when is detected now.
 - The number increases like 1 → 2 ... 38 → 39 after returning to the normal condition whenever IGN OFF → ON.
 - The number is fixed to 39 until the self-diagnosis results are erased if it is over 39.

×: Applicable

CONSULT display	Fail-safe	Refer to
No DTC is detected. further testing may be required.	—	—
U1000: CAN COMM CIRCUIT	×	PCS-16
B2098: IGN RELAY ON	×	PCS-17
B2099: IGN RELAY OFF	—	PCS-49

EXTERIOR LIGHTING SYSTEM SYMPTOMS

< SYMPTOM DIAGNOSIS >

SYMPTOM DIAGNOSIS

EXTERIOR LIGHTING SYSTEM SYMPTOMS WITHOUT DAYTIME RUNNING LIGHT SYSTEM

WITHOUT DAYTIME RUNNING LIGHT SYSTEM : Symptom Table

INFOID:000000005128604

CAUTION:

Perform the self-diagnosis with CONSULT-III before the symptom diagnosis. Perform the trouble diagnosis if any DTC is detected.

Symptom		Possible cause	Inspection item
Headlamp (HI) is not turned ON.	One side	<ul style="list-style-type: none"> • Fuse • Halogen bulb (HI) • Harness between IPDM E/R and the headlamp • Harness between headlamp and the ground • IPDM E/R 	Headlamp (HI) circuit Refer to EXL-47 .
	Both sides	Symptom diagnosis "BOTH SIDE HEADLAMPS (HI) ARE NOT TURNED ON" Refer to EXL-195 .	
High beam indicator lamp is not turned ON. [Headlamp (HI) is turned ON.]		Combination meter	<ul style="list-style-type: none"> • Combination meter • Data monitor "HI-BEAM IND" • BCM (HEADLAMP) • Active test "HEADLAMP"
Headlamp (LO) is not turned ON.	One side	<ul style="list-style-type: none"> • Fuse • Halogen bulb (LO) • Harness between IPDM E/R and the headlamp • Harness between headlamp and the ground • IPDM E/R 	Headlamp (LO) circuit Refer to EXL-50 .
	Both sides	Symptom diagnosis "BOTH SIDE HEADLAMPS (LO) ARE NOT TURNED ON" Refer to EXL-196 .	
Headlamp is not turned OFF.	When ignition switch is turned ON.	"BOTH SIDE HEADLAMPS (LO) ARE NOT TURNED ON" Refer to EXL-196 .	
	When ignition switch is turned OFF.	IPDM E/R	—
Headlamp is not turned ON/OFF with the lighting switch AUTO.		<ul style="list-style-type: none"> • Combination switch • Harness between the combination switch and BCM • BCM 	Combination switch Refer to BCS-147 .
		<ul style="list-style-type: none"> • Optical sensor • Harness between the optical sensor and BCM • BCM 	Optical sensor Refer to EXL-64 .
Front fog lamp is not turned ON.	One side	<ul style="list-style-type: none"> • Front fog lamp bulb • Harness between IPDM E/R and the front fog lamp • Front fog lamp • IPDM E/R 	Front fog lamp circuit Refer to EXL-55 .
	Both side	Symptom diagnosis "BOTH SIDE FRONT FOG LAMPS ARE NOT TURNED ON" Refer to EXL-198 .	
Front fog lamp is not turned ON.		<ul style="list-style-type: none"> • Parking lamp bulb • Harness between IPDM E/R and the parking lamp • Front combination lamp assembly • IPDM E/R 	Parking lamp circuit Refer to EXL-60 .

A
B
C
D
E
F
G
H
I
J
K

EXL

M
N
O
P

EXTERIOR LIGHTING SYSTEM SYMPTOMS

< SYMPTOM DIAGNOSIS >

Symptom		Possible cause	Inspection item
Tail lamp is not turned ON.		<ul style="list-style-type: none"> Tail lamp bulb Harness between IPDM E/R and the rear combination lamp Rear combination lamp assembly 	Tail lamp circuit Refer to EXL-69 .
Rear side marker lamp is not turned ON.		<ul style="list-style-type: none"> Rear side marker lamp bulb Harness between IPDM E/R and the rear side marker lamp Rear side marker lamp assembly 	Rear side marker lamp circuit Refer to EXL-71 .
License plate lamp is not turned ON.		<ul style="list-style-type: none"> License plate lamp bulb Harness between IPDM E/R and the license plate lamp License plate lamp assembly 	License plate lamp circuit Refer to EXL-72 .
<ul style="list-style-type: none"> Parking lamp, tail lamp, rear side marker lamp and license plate lamp are not turned ON. Parking lamp, tail lamp, rear side marker lamp and license plate lamp are not turned OFF. (Each illumination is turned ON/OFF.) 		Symptom diagnosis "PARKING, LICENSE PLATE, SIDE MARKER AND TAIL LAMPS ARE NOT TURNED ON" Refer to EXL-197 .	
Tail lamp indicator is not turned ON. (Parking and tail lamps are turned ON.)		Combination meter	<ul style="list-style-type: none"> Combination meter Data monitor "LIGHT IND" BCM (HEADLAMP) Active test "TAIL LAMP"
Turn signal lamp does not blink.	Indicator lamp is normal. (Applicable side performs the high flasher activation.)	<ul style="list-style-type: none"> Harness between BCM and each turn signal lamp Turn signal lamp bulb 	Turn signal circuit Refer to EXL-62 .
	Indicator lamp is included.	<ul style="list-style-type: none"> Combination switch Harness between the combination switch and BCM BCM 	Combination switch Refer to BCS-147 .
Turn signal indicator lamp does not blink. (Turn signal indicator lamp is normal.)	One side	Combination meter	—
	Both sides (Always)	<ul style="list-style-type: none"> Turn signal indicator lamp signal - BCM Combination meter 	<ul style="list-style-type: none"> Combination meter Data monitor "TURN IND" BCM (FLASHER) Active test "FLASHER"
	Both sides (Only when activating hazard warning lamp with the ignition switch OFF.)	<ul style="list-style-type: none"> Combination meter power supply and the ground circuit Combination meter 	Combination meter Power supply and the ground circuit Refer to MWI-39 .
<ul style="list-style-type: none"> Hazard warning lamp does not activate. Hazard warning lamp continues activating. (Turn signal is normal.) 		<ul style="list-style-type: none"> Hazard switch Harness between the hazard switch and BCM BCM 	Hazard switch Refer to EXL-67 .

WITH DAYTIME RUNNING LIGHT SYSTEM

WITH DAYTIME RUNNING LIGHT SYSTEM : Symptom Table

INFOID:000000005129216

CAUTION:

Perform the self-diagnosis with CONSULT-III before the symptom diagnosis. Perform the trouble diagnosis if any DTC is detected.

EXTERIOR LIGHTING SYSTEM SYMPTOMS

< SYMPTOM DIAGNOSIS >

Symptom	Possible cause	Inspection item	
Headlamp (HI) is not turned ON.	One side	<ul style="list-style-type: none"> • Fuse • Halogen bulb (HI) • Harness between IPDM E/R and the headlamp • Harness between the headlamp and the daytime running light relay-1 • Harness between the daytime running light relay-1 and the ground • Harness between the headlamp and the ground • Daytime running light relay-1 • IPDM E/R 	Headlamp (HI) circuit Refer to EXL-47 .
	Both sides	Symptom diagnosis "BOTH SIDE HEADLAMPS (HI) ARE NOT TURNED ON" Refer to EXL-195 .	
High beam indicator lamp is not turned ON. [Headlamp (HI) is turned ON.]	Combination meter	<ul style="list-style-type: none"> • Combination meter • Data monitor "HI-BEAM IND" • BCM (HEADLAMP) • Active test "HEADLAMP" 	
Headlamp (LO) is not turned ON.	One side	<ul style="list-style-type: none"> • Fuse • Halogen bulb (LO) • Harness between IPDM E/R and the headlamp • Harness between IPDM E/R and the daytime running light relay-2 • Harness between IPDM E/R and the headlamp • Harness between daytime running light relay-2 and the headlamp • Harness between the headlamp and the ground • Harness between the headlamp and the daytime running light relay-1 • Harness between the daytime running light relay-1 and the ground • Daytime running light relay-1 • Daytime running light relay-2 • IPDM E/R 	Headlamp (LO) circuit Refer to EXL-50 .
	Both sides	Symptom diagnosis "BOTH SIDE HEADLAMPS (LO) ARE NOT TURNED ON" Refer to EXL-196 .	
Headlamp is not turned OFF.	When ignition switch is turned ON.	"BOTH SIDE HEADLAMPS (LO) ARE NOT TURNED ON" Refer to EXL-196 .	
	When ignition switch is turned OFF.	IPDM E/R	—
Daytime running light is not turned ON. [Headlamp (HI) is turned ON.]	<ul style="list-style-type: none"> • Fuse • Harness between IPDM E/R and the daytime running light relay-1 • Daytime running light relay-1 • IPDM E/R • BCM • ECM • Combination meter 	<ul style="list-style-type: none"> • Daytime running light relay circuit • Refer to EXL-57. • BCM (HEADLAMP) • Data monitor "ENGINE STATE" • Combination meter • Data monitor "PKB SW" • BCM (HEADLAMP) • Active test "DAYTIME RUNNING LIGHT" 	

A
B
C
D
E
F
G
H
I
J
K
M
N
O
P

EXL

EXTERIOR LIGHTING SYSTEM SYMPTOMS

< SYMPTOM DIAGNOSIS >

Symptom		Possible cause	Inspection item
Headlamp is not turned ON/OFF with the lighting switch AUTO.		<ul style="list-style-type: none"> • Combination switch • Harness between the combination switch and BCM • BCM 	Combination switch Refer to BCS-80 .
		<ul style="list-style-type: none"> • Optical sensor • Harness between the optical sensor and BCM • BCM 	Optical sensor Refer to EXL-64 .
Front fog lamp is not turned ON.	One side	<ul style="list-style-type: none"> • Front fog lamp bulb • Harness between IPDM E/R and the front fog lamp • Front fog lamp • IPDM E/R 	Front fog lamp circuit Refer to EXL-55 .
	Both side	Symptom diagnosis “BOTH SIDE FRONT FOG LAMPS ARE NOT TURNED ON” Refer to EXL-198 .	
Front fog lamp is not turned ON.			
Parking lamp is not turned ON.		<ul style="list-style-type: none"> • Parking lamp bulb • Harness between IPDM E/R and the parking lamp • Front combination lamp assembly • IPDM E/R 	Parking lamp circuit Refer to EXL-60 .
Tail lamp is not turned ON.		<ul style="list-style-type: none"> • Tail lamp bulb • Harness between IPDM E/R and the rear combination lamp • Rear combination lamp assembly 	Tail lamp circuit Refer to EXL-69 .
Rear side marker lamp is not turned ON.		<ul style="list-style-type: none"> • Rear side marker lamp bulb • Harness between IPDM E/R and the rear side marker lamp • Rear side marker lamp assembly 	Rear side marker lamp circuit Refer to EXL-71 .
License plate lamp is not turned ON.		<ul style="list-style-type: none"> • License plate lamp bulb • Harness between IPDM E/R and the license plate lamp • License plate lamp assembly 	License plate lamp circuit Refer to EXL-72 .
<ul style="list-style-type: none"> • Parking lamp, tail lamp, rear side marker lamp and license plate lamp are not turned ON. • Parking lamp, tail lamp, rear side marker lamp and license plate lamp are not turned OFF. (Each illumination is turned ON/OFF.) 		Symptom diagnosis “PARKING, LICENSE PLATE, SIDE MARKER AND TAIL LAMPS ARE NOT TURNED ON” Refer to EXL-197 .	
Tail lamp indicator is not turned ON. (Parking and tail lamps are turned ON.)		Combination meter	<ul style="list-style-type: none"> • Combination meter • Data monitor “LIGHT IND” • BCM (HEADLAMP) • Active test “TAIL LAMP”
Turn signal lamp does not blink.	Indicator lamp is normal. (Applicable side performs the high flasher activation.)	<ul style="list-style-type: none"> • Harness between BCM and each turn signal lamp • Turn signal lamp bulb 	Turn signal circuit Refer to EXL-62 .
	Indicator lamp is included.	<ul style="list-style-type: none"> • Combination switch • Harness between the combination switch and BCM • BCM 	Combination switch Refer to BCS-80 .

EXTERIOR LIGHTING SYSTEM SYMPTOMS

< SYMPTOM DIAGNOSIS >

Symptom		Possible cause	Inspection item
Turn signal indicator lamp does not blink. (Turn signal indicator lamp is normal.)	One side	Combination meter	—
	Both sides (Always)	<ul style="list-style-type: none"> • Turn signal indicator lamp signal - BCM • Combination meter 	<ul style="list-style-type: none"> • Combination meter Data monitor "TURN IND" • BCM (FLASHER) Active test "FLASHER"
	Both sides (Only when activating hazard warning lamp with the ignition switch OFF.)	<ul style="list-style-type: none"> • Combination meter power supply and the ground circuit • Combination meter 	Combination meter Power supply and the ground circuit Refer to MWI-39 .
<ul style="list-style-type: none"> • Hazard warning lamp does not activate. • Hazard warning lamp continues activating. (Turn signal is normal.) 		<ul style="list-style-type: none"> • Hazard switch • Harness between the hazard switch and BCM • BCM 	Hazard switch Refer to EXL-67 .

A
B
C
D
E
F
G
H
I
J
K
L
M
N
O
P

EXL

NORMAL OPERATING CONDITION

< SYMPTOM DIAGNOSIS >

NORMAL OPERATING CONDITION

Description

INFOID:000000004992027

AUTO LIGHT SYSTEM

The headlamp may not be turned ON/OFF immediately after passing dark area or bright area (short tunnel, sky bridge, shadowed area etc.) while using the auto light system. This causes the control difference. This is normal.

BOTH SIDE HEADLAMPS (HI) ARE NOT TURNED ON

< SYMPTOM DIAGNOSIS >

BOTH SIDE HEADLAMPS (HI) ARE NOT TURNED ON

Description

INFOID:000000004992028

Both side headlamps (HI) are not turned ON when setting to the lighting switch HI or PASS.

Diagnosis Procedure

INFOID:000000004992029

1.COMBINATION SWITCH INSPECTION

Check the combination switch. Refer to [BCS-80. "Symptom Table"](#).

Is the combination switch normal?

YES >> GO TO 2.

NO >> Repair or replace the malfunctioning part.

2.CHECK HEADLAMP (HI) REQUEST SIGNAL INPUT

CONSULT-III DATA MONITOR

1. Select "HL HI REQ" of IPDM E/R data monitor item.
2. With operating the lighting switch, check the monitor status.

Monitor item	Condition		Monitor status
HL HI REQ	Lighting switch (2ND)	HI or PASS	ON
		LO	OFF

Is the item status normal?

YES >> GO TO 3.

NO >> Replace BCM. Refer to [BCS-82. "Exploded View"](#).

3.HEADLAMP (HI) CIRCUIT INSPECTION

Check the headlamp (HI) circuit. Refer to [EXL-47. "Component Function Check"](#).

Is the headlamp (HI) circuit normal?

YES >> Replace IPDM E/R.

NO >> Repair or replace the malfunctioning part.

A
B
C
D
E
F
G
H
I
J
K
M
N
O
P

EXL

BOTH SIDE HEADLAMPS (LO) ARE NOT TURNED ON

< SYMPTOM DIAGNOSIS >

BOTH SIDE HEADLAMPS (LO) ARE NOT TURNED ON

Description

INFOID:000000004992030

Both side headlamps (LO) are not turned ON in any condition.

Diagnosis Procedure

INFOID:000000004992031

1. CHECK COMBINATION SWITCH

Check the combination switch. Refer to [BCS-80, "Symptom Table"](#).

Is the combination switch normal?

YES >> GO TO 2.

NO >> Repair or replace the malfunctioning part.

2. CHECK HEADLAMP (LO) REQUEST SIGNAL INPUT

ⓈCONSULT-III DATA MONITOR

1. Select "HL LO REQ" of IPDM E/R data monitor item.
2. With operating the lighting switch, check the monitor status.

Monitor item	Condition	Monitor status	
HL LO REQ	Lighting switch	2ND	ON
		OFF	OFF

Is the item status normal?

YES >> GO TO 3.

NO >> Replace BCM. Refer to [BCS-82, "Exploded View"](#).

3. HEADLAMP (LO) CIRCUIT INSPECTION

Check the headlamp (LO) circuit. Refer to [EXL-50, "Component Function Check"](#).

Is the headlamp (LO) circuit normal?

YES >> Replace IPDM E/R.

NO >> Repair or replace the malfunctioning part.

PARKING, LICENSE PLATE, SIDE MARKER AND TAIL LAMPS ARE NOT TURNED ON

< SYMPTOM DIAGNOSIS >

PARKING, LICENSE PLATE, SIDE MARKER AND TAIL LAMPS ARE NOT TURNED ON

Description

INFOID:000000004992032

The parking, license plate, tail, rear side marker lamps and each illumination are not turned ON in any condition.

Diagnosis Procedure

INFOID:000000004992033

1.COMBINATION SWITCH INSPECTION

Check the combination switch. Refer to [BCS-80. "Symptom Table"](#).

Is the combination switch normal?

YES >> GO TO 2.

NO >> Repair or replace the malfunctioning part.

2.CHECK TAIL LAMP RELAY REQUEST SIGNAL INPUT

CONSULT-III DATA MONITOR

1. Select "TAIL & CLR REQ" of IPDM E/R data monitor item.
2. With operating the lighting switch, check the monitor status.

Monitor item	Condition	Monitor status
TAIL & CLR REQ	Lighting switch	1ST ON
		OFF OFF

Is the item status normal?

YES >> GO TO 3.

NO >> Replace BCM. Refer to [BCS-82. "Exploded View"](#).

3.TAIL LAMP CIRCUIT INSPECTION

Check the tail lamp circuit. Refer to [EXL-69. "Component Function Check"](#).

Is the tail lamp circuit normal?

YES >> Replace IPDM E/R.

NO >> Repair or replace the malfunctioning part.

A
B
C
D
E
F
G
H
I
J
K
EXL
M
N
O
P

BOTH SIDE FRONT FOG LAMPS ARE NOT TURNED ON

< SYMPTOM DIAGNOSIS >

BOTH SIDE FRONT FOG LAMPS ARE NOT TURNED ON

Description

INFOID:000000004992036

The front fog lamps are not turned ON in any condition.

Diagnosis Procedure

INFOID:000000004992037

1.CHECK FUSE

Check that the following fuse is fusing.

Unit	Location	Fuse No.	Capacity
Front fog lamp	IPDM E/R	#65	15 A

Is the fuse fusing?

- YES >> Repair the applicable circuit. And then replace the fuse.
- NO >> GO TO 2.

2.COMBINATION SWITCH INSPECTION

Check the combination switch. Refer to [BCS-80, "Symptom Table"](#).

Is the combination switch normal?

- YES >> GO TO 3.
- NO >> Repair or replace the malfunctioning part.

3.CHECK FRONT FOG LAMP REQUEST SIGNAL INPUT

ⓅCONSULT-III DATA MONITOR

1. Select "FR FOG REQ" of IPDM E/R data monitor item.
2. With operating the front fog lamp switch, check the monitor status.

Monitor item	Condition	Monitor status	
FR FOG REQ	Front fog lamp switch (With lighting switch 1ST)	ON	ON
		OFF	OFF

Is the item status normal?

- YES >> GO TO 4.
- NO >> Replace BCM. Refer to [BCS-82, "Exploded View"](#).

4.FRONT FOG LAMP CIRCUIT INSPECTION

Check the front fog lamp circuit. Refer to [EXL-55, "Component Function Check"](#).

Is the front fog lamp circuit normal?

- YES >> Replace IPDM E/R.
- NO >> Repair or replace the malfunctioning part.

PRECAUTIONS

< PRECAUTION >

PRECAUTION

PRECAUTIONS

Precaution for Supplemental Restraint System (SRS) "AIR BAG" and "SEAT BELT PRE-TENSIONER"

INFOID:000000005183998

The Supplemental Restraint System such as "AIR BAG" and "SEAT BELT PRE-TENSIONER", used along with a front seat belt, helps to reduce the risk or severity of injury to the driver and front passenger for certain types of collision. This system includes seat belt switch inputs and dual stage front air bag modules. The SRS system uses the seat belt switches to determine the front air bag deployment, and may only deploy one front air bag, depending on the severity of a collision and whether the front occupants are belted or unbelted. Information necessary to service the system safely is included in the "SRS AIR BAG" and "SEAT BELT" of this Service Manual.

WARNING:

- To avoid rendering the SRS inoperative, which could increase the risk of personal injury or death in the event of a collision which would result in air bag inflation, all maintenance must be performed by an authorized NISSAN/INFINITI dealer.
- Improper maintenance, including incorrect removal and installation of the SRS, can lead to personal injury caused by unintentional activation of the system. For removal of Spiral Cable and Air Bag Module, see the "SRS AIR BAG".
- Do not use electrical test equipment on any circuit related to the SRS unless instructed to in this Service Manual. SRS wiring harnesses can be identified by yellow and/or orange harnesses or harness connectors.

PRECAUTIONS WHEN USING POWER TOOLS (AIR OR ELECTRIC) AND HAMMERS

WARNING:

- When working near the Air Bag Diagnosis Sensor Unit or other Air Bag System sensors with the ignition ON or engine running, DO NOT use air or electric power tools or strike near the sensor(s) with a hammer. Heavy vibration could activate the sensor(s) and deploy the air bag(s), possibly causing serious injury.
- When using air or electric power tools or hammers, always switch the ignition OFF, disconnect the battery, and wait at least 3 minutes before performing any service.

A
B
C
D
E
F
G
H
I
J
K
L
M
N
O
P

EXL

HEADLAMP AIMING ADJUSTMENT

< PERIODIC MAINTENANCE >

PERIODIC MAINTENANCE

HEADLAMP AIMING ADJUSTMENT

Description

INFOID:000000004992190

PREPARATION BEFORE ADJUSTING

NOTE:

- For details, refer to the regulations in your own country.
- Perform aiming if the vehicle front body has been repaired and/or the headlamp assembly has been replaced.

Before performing aiming adjustment, check the following.

- Adjust the tire pressure to the specification.
- Fill with fuel, engine coolant and each oil.
- Maintain the unloaded vehicle condition. (Remove luggage from the passenger compartment and the trunk room.)

NOTE:

Do not remove the temporary tire, jack and on-vehicle tool.

- Wipe out dirt on the headlamp.

CAUTION:

Never use organic solvent (thinner, gasoline etc.)

- Ride alone on the driver seat.

AIMING ADJUSTMENT SCREW

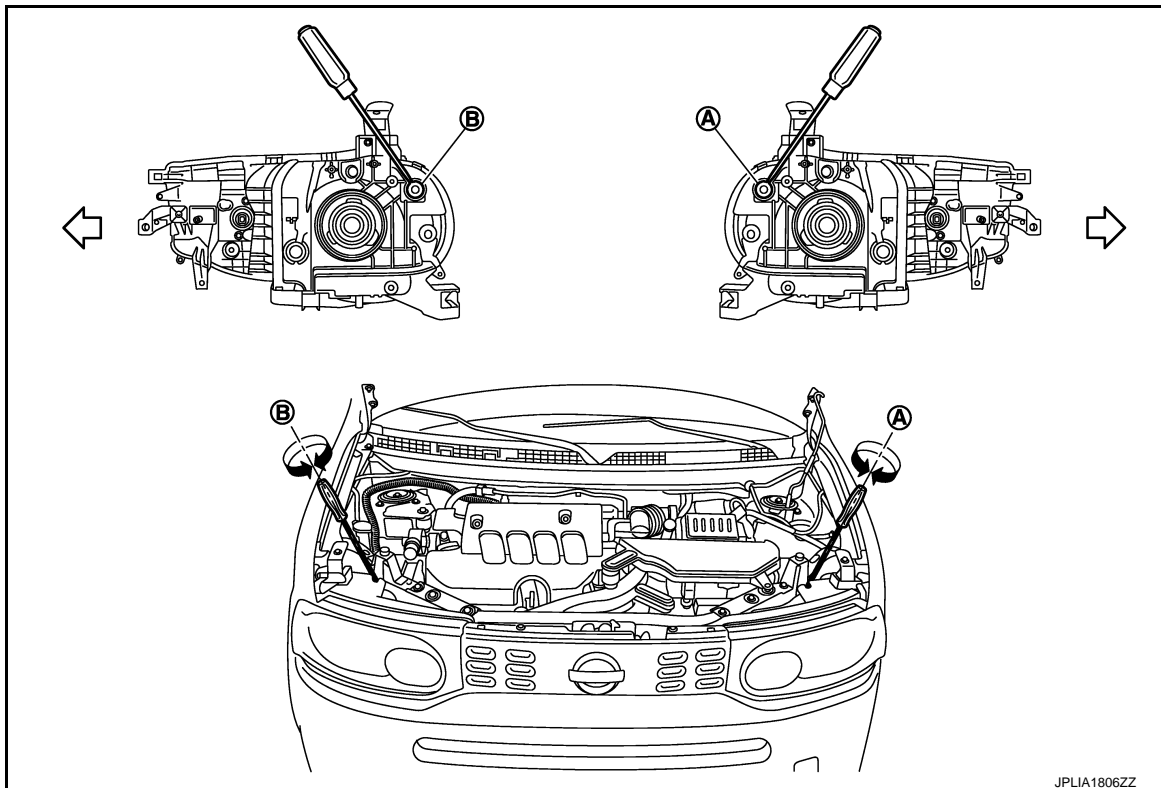

A Headlamp (RH) UP/DOWN adjustment screw

B. Headlamp (LH) UP/DOWN adjustment screw

↔: Vehicle center

JPLIA1806ZZ

HEADLAMP AIMING ADJUSTMENT

< PERIODIC MAINTENANCE >

Adjustment screw		Screw driver rotation	Facing direction
A	Headlamp (RH) UP/DOWN	Clockwise	DOWN
		Counterclockwise	UP
B	Headlamp (LH) UP/DOWN	Clockwise	DOWN
		Counterclockwise	UP

Aiming Adjustment Procedure

INFOID:000000004992191

- Place the screen.

NOTE:

- Stop the vehicle facing the wall.
- Place the board on a plain road vertically.

- Face the vehicle with the screen. Maintain 10 m (32.8 ft) between the headlamp center and the screen.
- Start the engine. Turn the headlamp (LO) ON.

NOTE:

Shut off the headlamp light with the board to prevent from illuminating the adjustment screen.

CAUTION:

Never cover the lens surface with a tape etc. The lens is made of resin.

- Measure the distance (X) between the horizontal center line of headlamp (H) and the cutoff line (A) within the light axis measurement range (R) from the vertical center line ahead of headlamp (V).

Light axis measurement range (R) : 350 ± 175 mm (13.78 ± 6.89 in)

Low beam distribution on the screen

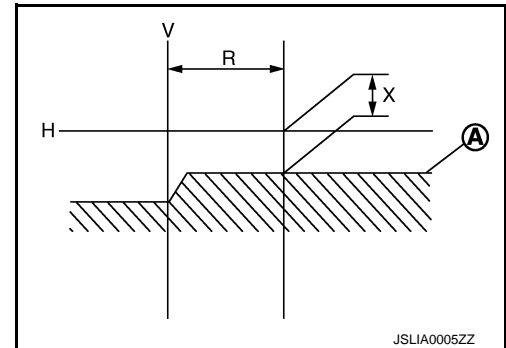

- Adjust the cutoff line height (X) with the aiming adjustment screw so as to enter in the adjustment range (M–N) according to the horizontal center line of headlamp (H).

unit: mm (in)

Horizontal center line of headlamp (H)	Highest cutoff line height (M)	Lowest cutoff line height (N)
700 (27.56) or less	4 (0.16)	30 (1.18)
701 (27.60) – 800 (31.50)	4 (0.16)	30 (1.18)
801 (31.54) or more	17 (0.67)	44 (1.73)

Side view

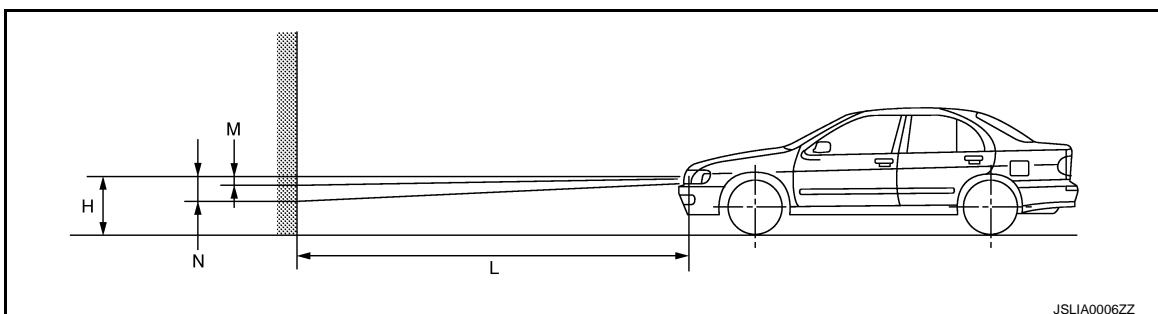

JSLIA0006ZZ

HEADLAMP AIMING ADJUSTMENT

< PERIODIC MAINTENANCE >

Distance between the headlamp center and the screen (L) : 10 m (32.8 ft)

FRONT FOG LAMP AIMING ADJUSTMENT

< PERIODIC MAINTENANCE >

FRONT FOG LAMP AIMING ADJUSTMENT

Description

INFOID:000000004992042

PREPARATION BEFORE ADJUSTING

NOTE:

- For details, refer to the regulations in your own country.

Before performing aiming adjustment, check the following.

- Adjust the tire pressure to the specification.
- Fill with fuel, engine coolant and each oil.
- Maintain the unloaded vehicle condition. (Remove luggage from the passenger compartment and the luggage room.)

NOTE:

Do not remove the temporary tire, jack and on-vehicle tool.

- Wipe out dirt on the headlamp.

CAUTION:

Never use organic solvent (thinner, gasoline etc.)

- Ride alone on the driver seat.

AIMING ADJUSTMENT SCREW

- Turn the aiming adjusting screw for adjustment.

A: UP

B: DOWN

- For the position and direction of the adjusting screw, refer to the figure.

NOTE:

A screwdriver or hexagonal wrench [6 mm (0.24 in)] can be used for adjustment.

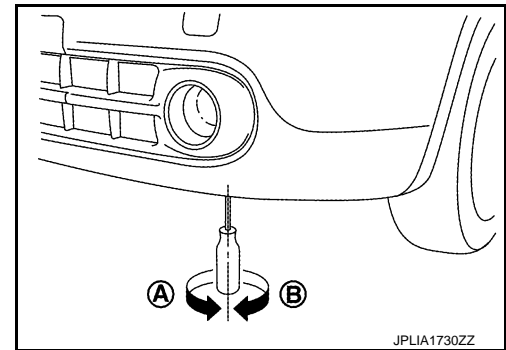

Aiming Adjustment Procedure

INFOID:000000004992043

1. Place the screen.

NOTE:

- Stop the vehicle facing the wall.
- Place the board on a plain road vertically.

2. Face the vehicle with the screen. Maintain 10 m (32.8 ft) between the front fog lamp center and the screen.

3. Start the engine. Illuminate the front fog lamp.

CAUTION:

Never cover the lens surface with a tape etc. The lens is made of resin.

NOTE:

Shut off the headlamp light with the board to prevent from illuminating the adjustment screen.

4. Adjust the cutoff line height (A) with the aiming adjustment screw so that the distance (X) between the horizontal center line of front fog lamp (H) and (A) becomes 200 mm (7.87 in).

Front fog lamp light distribution on the screen

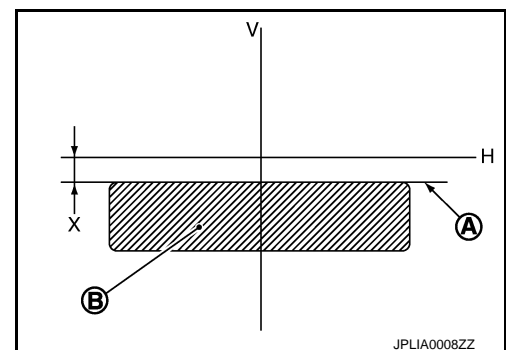

FRONT FOG LAMP AIMING ADJUSTMENT

< PERIODIC MAINTENANCE >

- A : Cutoff line
- B : High illuminance area
- H : Horizontal center line of front fog lamp
- V : Vertical center line of front fog lamp
- X : Cutoff line height

FRONT COMBINATION LAMP

< REMOVAL AND INSTALLATION >

REMOVAL AND INSTALLATION

FRONT COMBINATION LAMP

Exploded View

INFOID:000000004992046

REMOVAL

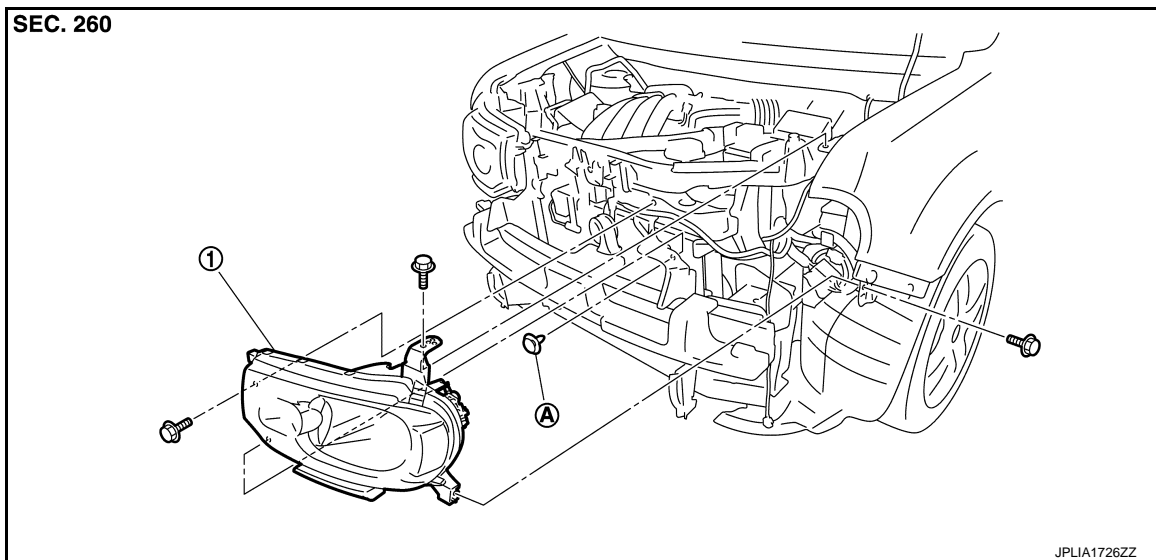

- 1. Front combination lamp
- A. Air duct clip(only left)

DISASSEMBLY

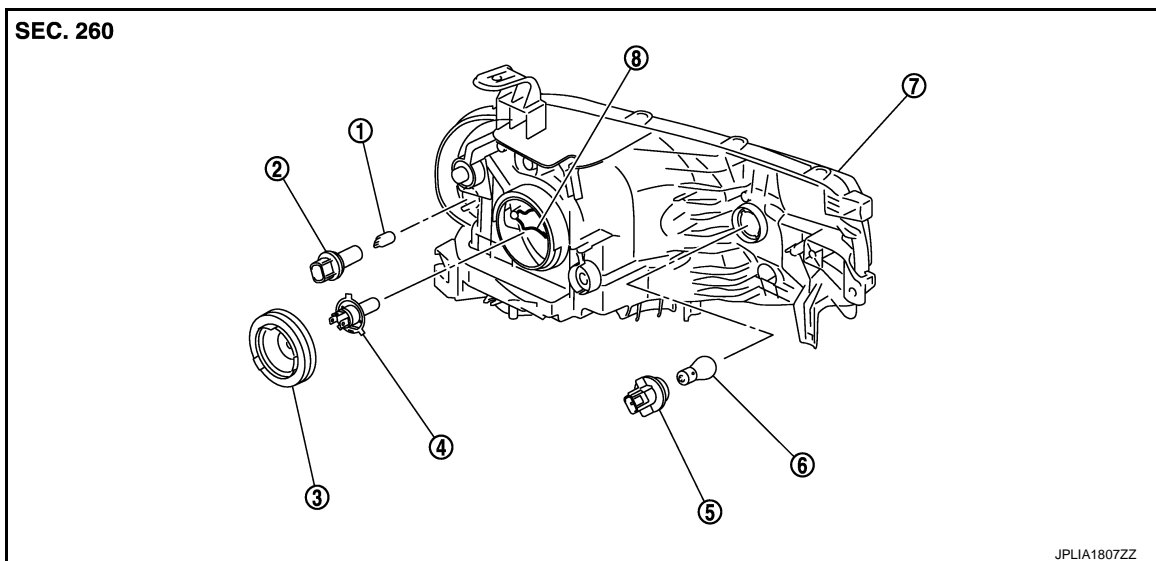

- 1. Parking(side marker) lamp bulb
- 2. Parking(side marker)lamp bulb socket
- 3. Back cover
- 4. Halogen bulb
- 5. Front turn signal lamp bulb socket
- 6. Front turn signal lamp bulb
- 7. Headlamp housing assembly
- 8. Retaining spring

Removal and Installation

INFOID:000000004992047

REMOVAL

A
B
C
D
E
F
G
H
I
J
K
EXL
M
N
O
P

FRONT COMBINATION LAMP

< REMOVAL AND INSTALLATION >

CAUTION:

Disconnect the battery negative terminal or the fuse.

1. Remove front bumper fascia. Refer to [EXT-12, "Exploded View"](#).
2. Remove the harness clips (A)*.
*: When replace a left.
3. Remove the air duct clip*.
*: When replace a left.
4. Remove the headlamp mounting bolts.
5. Pull out the headlamp assembly forward the vehicle.
6. Disconnect the connector before removing the headlamp assembly.

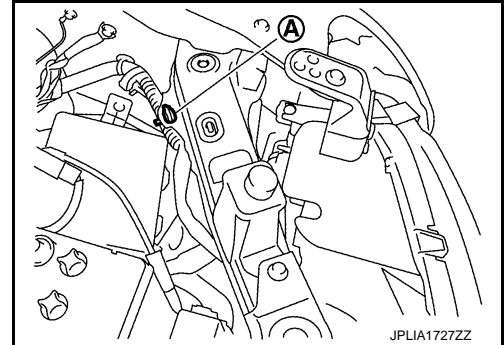

INSTALLATION

Install in the reverse order of removal.

NOTE:

After installation, perform aiming adjustment. Refer to [EXL-200, "Description"](#).

Replacement

INFOID:000000004992048

CAUTION:

- Disconnect the battery negative terminal or the fuse.
- After installing the bulb, install the resin cap and the bulb socket securely for watertightness.
- Never touch the glass of bulb directly by hand. Keep grease and other oily matters away from it.
- Never touch bulb by hand while it is lit or right after being turned off.
- Never leave bulb out of lamp reflector for a long time because dust, moisture smoke, etc. may affect the performance of lamp. When replacing bulb, be sure to replace it with new one.

HEADLAMP BULB

1. Disconnect the headlamp bulb connector.
2. Remove the back cover.
3. Remove the retaining spring lock. And remove the bulb from the headlamp housing assembly.

PARKING(FRONT SIDE MARKER) LAMP BULB

1. Remove the fender protector. Refer to [EXT-22, "FENDER PROTECTOR : Exploded View"](#). Keep a service area.
2. Rotate the bulb socket counterclockwise and unlock it.
3. Remove the bulb from the bulb socket.

FRONT TURN SIGNAL LAMP BULB

1. Rotate the bulb socket counterclockwise and unlock it.
2. Remove the bulb from the bulb socket.

Disassembly and Assembly

INFOID:000000004992049

DISASSEMBLY

1. Remove the back cover.
2. Remove the retaining spring lock. And remove the bulb from the headlamp housing assembly.
3. Rotate the parking(front side marker) lamp bulb socket counterclockwise and unlock it.
4. Remove the bulb from the parking(front side marker) lamp bulb socket.
5. Rotate the front turn signal lamp bulb socket counterclockwise and unlock it.
6. Remove the bulb from the front turn signal lamp bulb socket.

ASSEMBLY

Assemble in the reverse order of disassembly.

CAUTION:

FRONT COMBINATION LAMP

< REMOVAL AND INSTALLATION >

After installing the bulb, install the resin cap and the bulb socket securely for watertightness.

A

B

C

D

E

F

G

H

I

J

K

EXL

M

N

O

P

FRONT FOG LAMP

< REMOVAL AND INSTALLATION >

FRONT FOG LAMP

Exploded View

INFOID:000000004992050

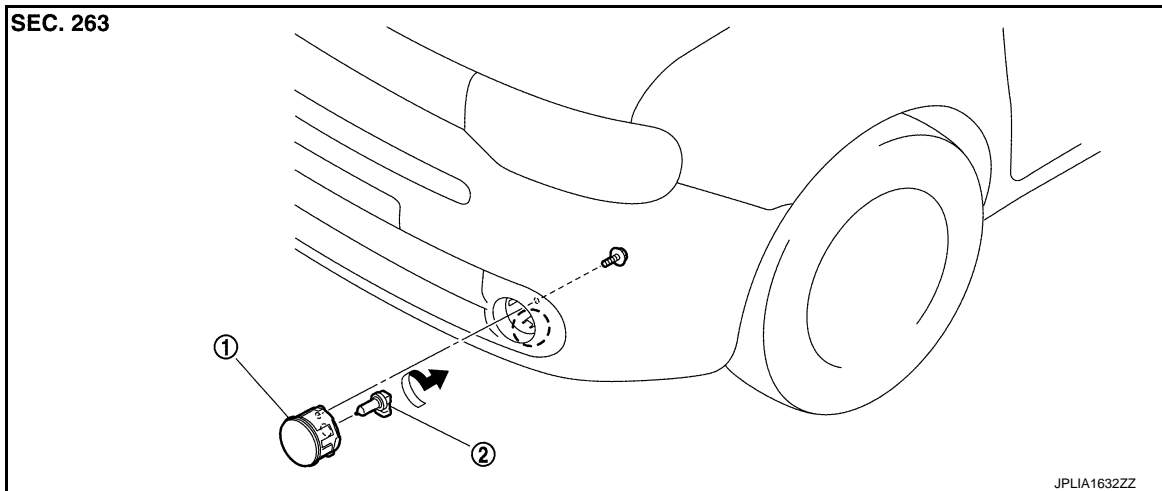

1. Front fog lamp
2. Front fog lamp bulb

○ : Pawl

Removal and Installation

INFOID:000000004992051

CAUTION:

Disconnect the battery negative terminal or the fuse.

REMOVAL

1. Remove the fender protector. Refer to [EXT-22. "FENDER PROTECTOR : Exploded View"](#).
2. Remove the front fog lamp connector.
3. Remove the front fog lamp mounting bolt.
4. While pressing pawls, remove the front fog lamp.

INSTALLATION

Installation is the reverse order of removal.

NOTE:

After installation, perform aiming adjustment. Refer to [EXL-203. "Description"](#).

Replacement

INFOID:000000004992052

CAUTION:

- Disconnect the battery negative terminal or the fuse.
- Never touch the glass of bulb directly by hand. Keep grease and other oily matters away from it.
- Never touch bulb by hand while it is lit or right after being turned off.
- Never leave bulb out of lamp reflector for a long time because dust, moisture smoke, etc. may affect the performance of lamp. When replacing bulb, be sure to replace it with new one.

FRONT FOG LAMP BULB

1. Remove the fender protector. Keep the service area. Refer to [EXT-22. "FENDER PROTECTOR : Exploded View"](#).

FRONT FOG LAMP

< REMOVAL AND INSTALLATION >

2. Remove the front fog lamp bulb connector (1).
3. Rotate the bulb (2) counterclockwise and unlock it.

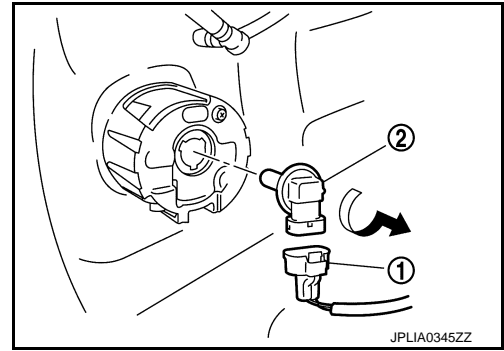

A

B

C

D

E

F

G

H

I

J

K

EXL

M

N

O

P

OPTICAL SENSOR

< REMOVAL AND INSTALLATION >

OPTICAL SENSOR

Exploded View

INFOID:000000004992177

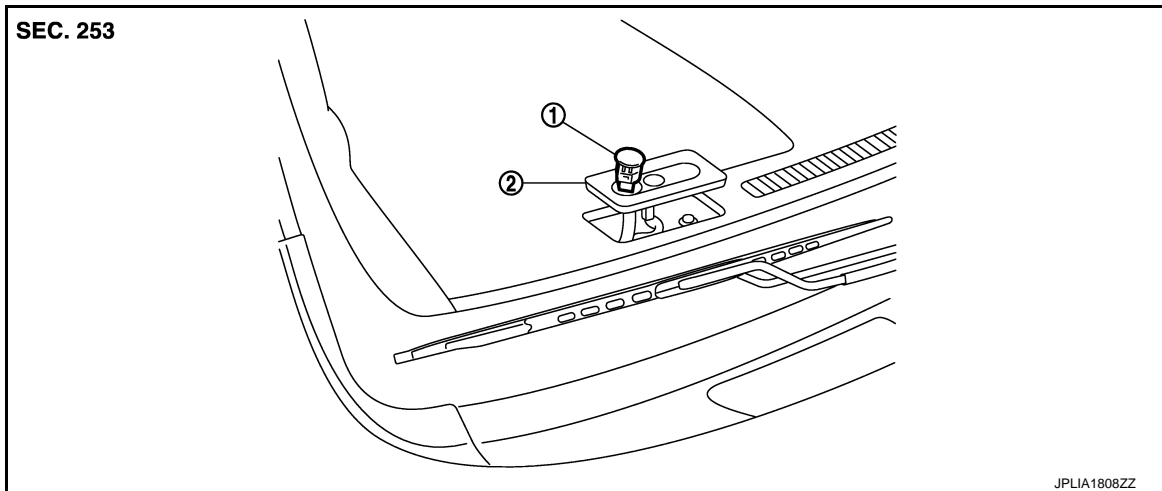

1. Optical sensor

2. Instrument mask

Removal and Installation

INFOID:000000004992178

REMOVAL

1. Remove the instrument mask.
2. Disconnect the connector. Remove the optical sensor.

INSTALLATION

Install in the reverse order of removal.

LIGHTING & TURN SIGNAL SWITCH

< REMOVAL AND INSTALLATION >

LIGHTING & TURN SIGNAL SWITCH

Exploded View

INFOID:000000005022925

The lighting & turn switch is integrated in the combination switch. Refer to [BCS-83. "Exploded View"](#).

A

B

C

D

E

F

G

H

I

J

K

EXL

M

N

O

P

SIDE TURN SIGNAL LAMP

< REMOVAL AND INSTALLATION >

SIDE TURN SIGNAL LAMP

Exploded View

INFOID:000000004992060

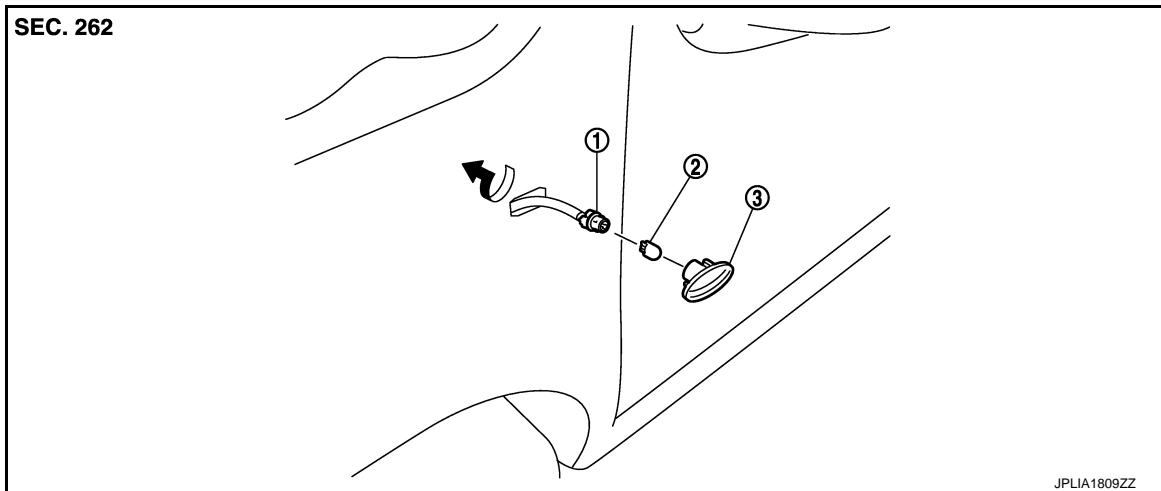

1. Side turn signal lamp bulb socket
2. Side turn signal lamp bulb
3. Side turn signal lamp housing

Removal and Installation

INFOID:000000004992061

CAUTION:

Disconnect battery negative terminal or remove the fuse.

REMOVAL

1. Remove the side turn signal lamp in numerical order shown in the figure.

↔ : Installable both direction

2. Rotate the bulb socket counterclockwise and unlock it.

NOTE:

Support side turn signal lamp harness with tape so that it won't fall into the front fender.

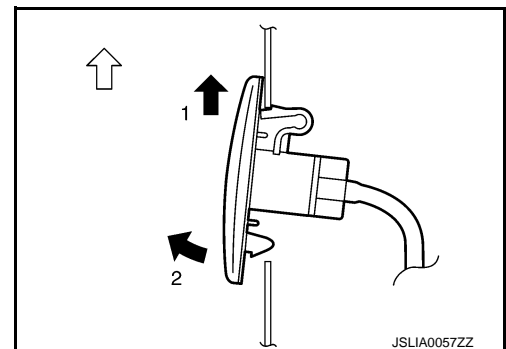

INSTALLATION

1. Rotate the bulb socket clockwise and lock it.
2. Fix the pawl-side behind the side turn signal lamp housing first, then push the resin clip-side.

Replacement

INFOID:000000004992062

CAUTION:

- Disconnect battery negative terminal or remove the fuse.
- Never touch the glass of bulb directly by hand. Keep grease and other oily matters away from it.
- Never touch bulb by hand while it is lit or right after being turned off.
- Never leave bulb out of lamp reflector for a long time because dust, moisture smoke, etc. may affect the performance of lamp. When replacing bulb, be sure to replace it with new one.

SIDE TURN SIGNAL LAMP BULB

1. Remove the side turn signal lamp.
2. Rotate the bulb socket counterclockwise and unlock it.

NOTE:

SIDE TURN SIGNAL LAMP

< REMOVAL AND INSTALLATION >

Support the vehicle-side harness of the side turn signal lamp with tape so that it does not drop inside the front fender.

3. Remove the bulb from the bulb socket.

A

B

C

D

E

F

G

H

I

J

K

EXL

M

N

O

P

HAZARD SWITCH

< REMOVAL AND INSTALLATION >

HAZARD SWITCH

Exploded View

INFOID:000000004992063

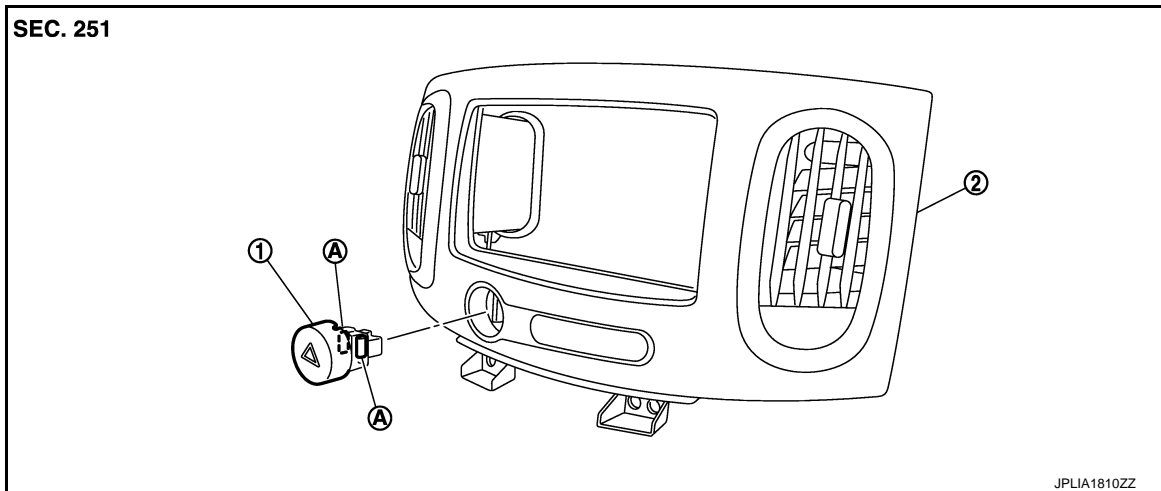

- 1. Hazard switch
- 2. Cluster lid C
- A. Pawl

Removal and Installation

INFOID:000000004992064

REMOVAL

1. Remove the cluster lid C. Refer to [IP-12. "Exploded View"](#).
2. While pressing pawls, push the hazard switch. And remove it.

INSTALLATION

Install in the reverse order of removal.

REAR COMBINATION LAMP

< REMOVAL AND INSTALLATION >

REAR COMBINATION LAMP

Exploded View

INFOID:000000004992069

REMOVAL

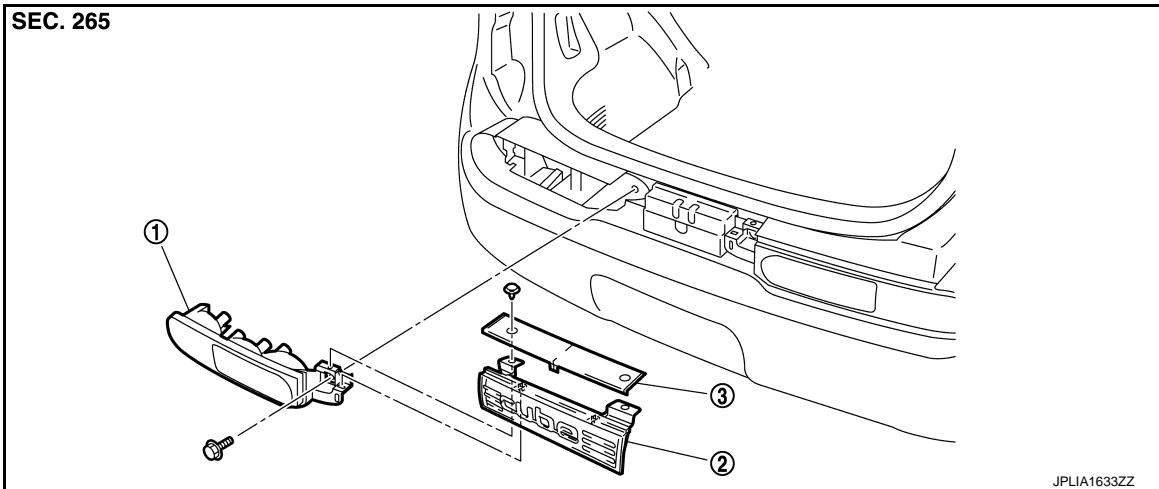

1. Rear combination lamp 2. Back door finisher 3. Back door finisher cover

DISASSEMBLY

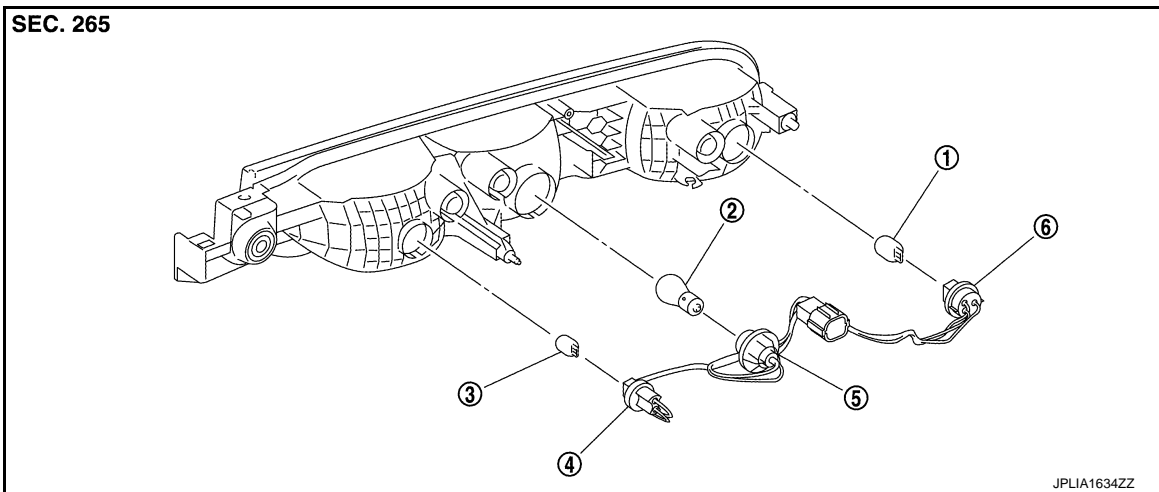

1. Stop/tail lamp bulb 2. Rear turn signal lamp bulb 3. Reverse lamp bulb
4. Reverse lamp bulb socket 5. Rear turn signal lamp bulb socket 6. Stop/tail lamp bulb socket

Removal and Installation

INFOID:000000004992070

CAUTION:

- Disconnect the battery negative terminal or the fuse.
- Wrap the tip of remover tool with a cloth to protect the body from damage.

REMOVAL

1. Remove rear back door finisher cover.

A
B
C
D
E
F
G
H
I
J
K
L
M
N
O
P

EXL

REAR COMBINATION LAMP

< REMOVAL AND INSTALLATION >

2. Disengage backdoor finisher mounting fastener (A) to remove the back door finisher.

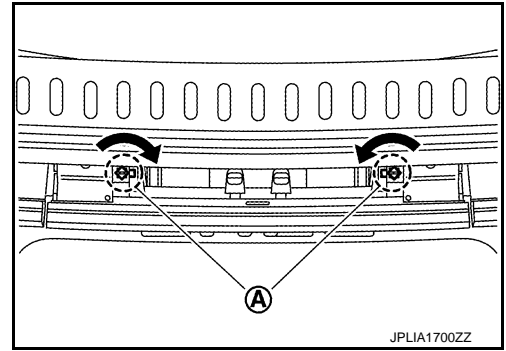

3. Remove rear combination lamp mounting bolts.
4. Slightly turn the rear combination lamp to leave a clearance.

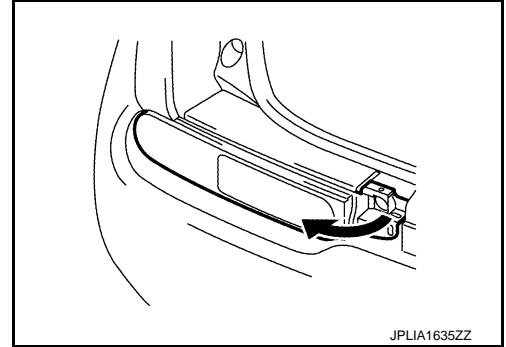

5. Insert an appropriate tool into the clearance between the rear combination lamp and the rear bumper side bracket.

CAUTION:

Since the rear combination lamp has another clip at the lower center, be careful when removing the outer clip.

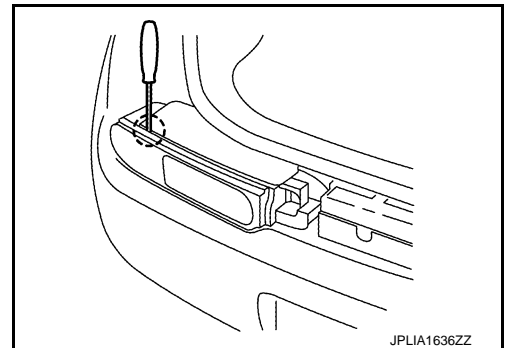

6. Pull rear combination lamp rearward to remove.
7. Disconnect rear combination lamp connector.

INSTALLATION

Install in the reverse order of removal.

NOTE:

The back door finisher mounting fastener remains on the rear combination lamp side after removing the back door finisher. Therefore, be sure to install the mounting fastener on the back door finisher side.

Replacement

INFOID:000000004992071

CAUTION:

- Disconnect the battery negative terminal or the fuse.
- Never touch the glass of bulb directly by hand. Keep grease and other oily matters away from it.
- Never touch bulb by hand while it is lit or right after being turned off.
- Never leave bulb out of lamp reflector for a long time because dust, moisture smoke, etc. may affect the performance of lamp. When replacing bulb, be sure to replace it with new one.

STOP/TAIL LAMP BULB

1. Remove rear combination lamp assembly.
2. Rotate the stop/tail lamp bulb socket counterclockwise, and unlock it.
3. Remove bulb from the bulb socket.

REAR COMBINATION LAMP

< REMOVAL AND INSTALLATION >

REAR TURN SIGNAL LAMP BULB

1. Remove rear combination lamp assembly.
2. Rotate the rear turn signal lamp bulb socket counterclockwise, and unlock it.
3. Remove bulb from the bulb socket.

BACK-UP LAMP BULB

1. Remove rear combination lamp assembly.
2. Rotate the back-up lamp bulb socket counterclockwise, and unlock it.
3. Remove bulb from the bulb socket.

A

B

C

D

E

F

G

H

I

J

K

EXL

M

N

O

P

REAR SIDE MARKER LAMP

< REMOVAL AND INSTALLATION >

REAR SIDE MARKER LAMP

Exploded View

INFOID:000000005022478

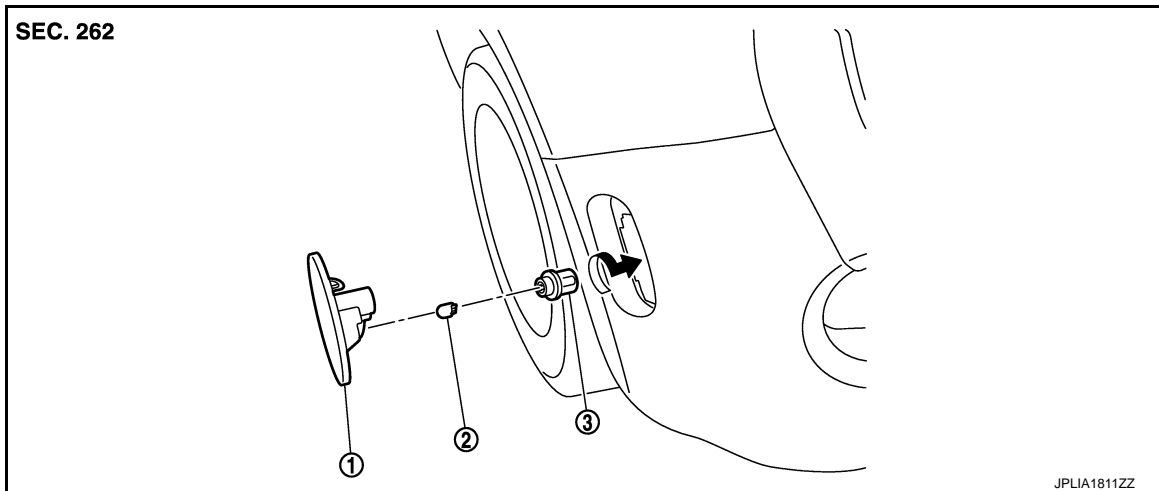

1. Rear side marker lamp housing
2. Rear side marker lamp
3. Rear side marker lamp socket

Removal and Installation

INFOID:000000005022479

REMOVAL

CAUTION:

Disconnect the battery negative terminal or remove the fuse.

1. Remove rear bumper closing. Refer to [EXT-15, "Exploded View"](#).
2. Disconnect rear side marker lamp connector.
3. Remove rear side marker lamp in numerical order shown in the figure.

← :Vehicle front

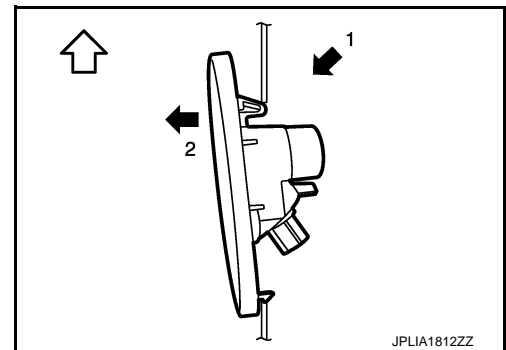

INSTALLATION

Install in the reverse order of removal.

Replacement

INFOID:000000005106439

CAUTION:

- **Disconnect battery negative terminal or remove the fuse.**
- **Never touch the glass of bulb directly by hand. Keep grease and other oily matters away from it.**
- **Never touch bulb by hand while it is lit or right after being turned off.**
- **Never leave bulb out of lamp reflector for a long time because dust, moisture smoke, etc. may affect the performance of lamp. When replacing bulb, be sure to replace it with new one.**

REAR SIDE MARKER LAMP BULB

1. Remove the rear side marker lamp.
2. Rotate the bulb socket counterclockwise and unlock it.
3. Remove the bulb from the bulb socket.

HIGH-MOUNTED STOP LAMP

< REMOVAL AND INSTALLATION >

HIGH-MOUNTED STOP LAMP

Exploded View

INFOID:000000004992072

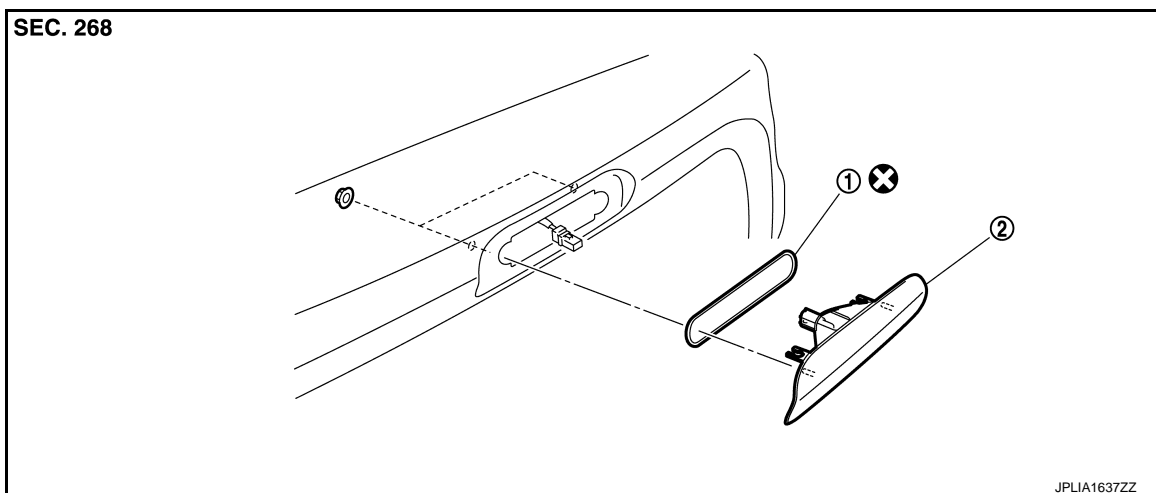

1. Seal packing
2. High-mounted stop lamp

Refer to [GI-4, "Components"](#) for symbols in the figure.

Removal and Installation

INFOID:000000004992073

CAUTION:

Disconnect battery negative terminal or remove the fuse.

REMOVAL

1. Remove the back door finisher upper. Refer to [INT-26, "Exploded View"](#).
2. Remove the mounting nuts.
3. Disconnect the high-mounted stop lamp connector.
4. Pull the high-mounted stop lamp toward rear of the vehicle.

INSTALLATION

Install in the reverse order of removal.

CAUTION:

Seal packing cannot be reused.

Replacement

INFOID:0000000005022990

CAUTION:

- Disconnect the battery negative terminal or the fuse.
- Never touch the glass of bulb directly by hand. Keep grease and other oily matters away from it.
- Never touch bulb by hand while it is lit or right after being turned off.
- Never leave bulb out of lamp reflector for a long time because dust, moisture smoke, etc. may affect the performance of lamp. When replacing bulb, be sure to replace it with new one.

HIGH-MOUNTED STOP LAMP BULB

1. Remove the back door finisher upper. Refer to [INT-26, "Exploded View"](#).

A
B
C
D
E
F
G
H
I
J
K
EXL
M
N
O
P

HIGH-MOUNTED STOP LAMP

< REMOVAL AND INSTALLATION >

2. Rotate the bulb socket(1) counterclockwise, and unlock it.
3. Remove the bulb from the bulb(2) socket.

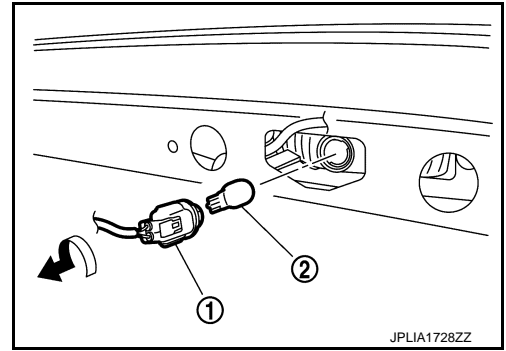

LICENSE PLATE LAMP

< REMOVAL AND INSTALLATION >

LICENSE PLATE LAMP

Exploded View

INFOID:000000004992183

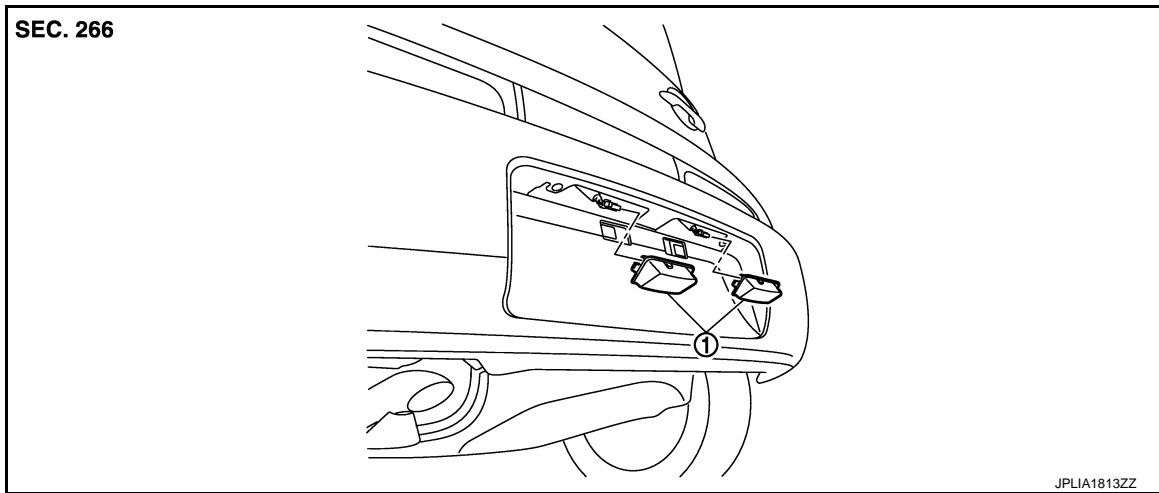

1. License plate lamp

Removal and Installation

INFOID:000000004992184

CAUTION:

Disconnect the battery negative terminal or remove the fuse.

REMOVAL

1. Remove the license plate lamp in numerical order.
2. Disconnect the license plate lamp connector.
3. Remove the license plate lamp.

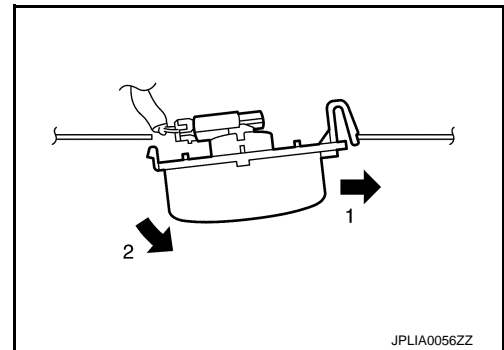

INSTALLATION

1. Connect the license plate lamp connector.
2. Fix the pawl side. And then push the resin clip side.

Replacement

INFOID:000000004992185

CAUTION:

- **Disconnect the battery negative terminal or remove the fuse.**
- **Never touch the glass of bulb directly by hand. Keep grease and other oily matters away from it.**
- **Never touch bulb by hand while it is lit or right after being turned off.**
- **Never leave bulb out of lamp reflector for a long time because dust, moisture smoke, etc. may affect the performance of lamp. When replacing bulb, be sure to replace it with new one.**

LICENSE PLATE LAMP BULB

1. Remove the license plate lamp.

LICENSE PLATE LAMP

< REMOVAL AND INSTALLATION >

2. Turn the bulb socket (1) counterclockwise and unlock it.
3. Remove the bulb (2) from the socket.

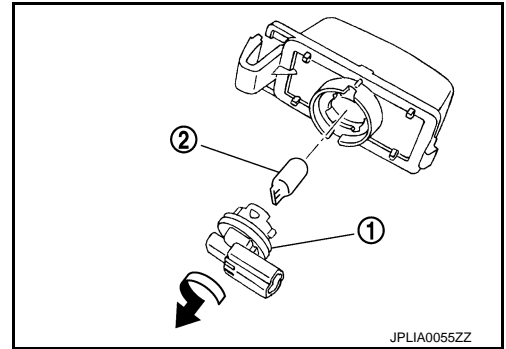

SERVICE DATA AND SPECIFICATIONS (SDS)

< SERVICE DATA AND SPECIFICATIONS (SDS)

SERVICE DATA AND SPECIFICATIONS (SDS)

SERVICE DATA AND SPECIFICATIONS (SDS)

Bulb Specifications

INFOID:000000004992083

Item	Type	Wattage (W)
Front combination lamp	Headlamp (HI/LO)	H4 60/55
	Front turn signal lamp	PY21W (Amber) 21
	Parking(front side marker) lamp	W5W 5
Front fog lamp	H8 35	
Side turn signal lamp	WY5W (Amber) 5	
Rear combination lamp	Stop lamp/Tail lamp	W21/5W 21/5
	Rear turn signal lamp	PY21W 16
	Back-up lamp	W16W 21
License plate lamp	W5W 5	
High-mounted stop lamp	W16W —	
Rear side marker lamp	W5W 5	

A
B
C
D
E
F
G
H
I
J
K
EXL
M
N
O
P