

SECTION **ST**
STEERING SYSTEM

A
 B
 C
 D
 E
 F
ST
 H
 I
 J
 K
 L
 M
 N
 O
 P

CONTENTS

<p>SYMPTOM DIAGNOSIS 2</p> <p>NOISE, VIBRATION AND HARSHNESS (NVH) TROUBLESHOOTING 2</p> <p style="padding-left: 20px;">NVH Troubleshooting Chart2</p> <p>PRECAUTION 3</p> <p>PRECAUTIONS 3</p> <p style="padding-left: 20px;">Precaution for Supplemental Restraint System (SRS) "AIR BAG" and "SEAT BELT PRE-TENSIONER"3</p> <p style="padding-left: 20px;">Precaution Necessary for Steering Wheel Rotation after Battery Disconnect3</p> <p style="padding-left: 20px;">Service Notice or Precautions for Steering System4</p> <p>PREPARATION 5</p> <p>PREPARATION 5</p> <p style="padding-left: 20px;">Special Service Tools5</p> <p style="padding-left: 20px;">Commercial Service Tools6</p> <p>PERIODIC MAINTENANCE 7</p> <p>STEERING WHEEL 7</p> <p style="padding-left: 20px;">Inspection7</p> <p>REMOVAL AND INSTALLATION 9</p> <p>STEERING WHEEL 9</p>	<p style="padding-left: 20px;">Exploded View 9</p> <p style="padding-left: 20px;">Removal and Installation 9</p> <p style="padding-left: 20px;">Disassembly and Assembly10</p> <p>STEERING COLUMN 11</p> <p style="padding-left: 20px;">Exploded View 11</p> <p style="padding-left: 20px;">Removal and Installation 11</p> <p style="padding-left: 20px;">Inspection 12</p> <p>STEERING GEAR AND LINKAGE 14</p> <p style="padding-left: 20px;">Exploded View 14</p> <p style="padding-left: 20px;">Removal and Installation 15</p> <p style="padding-left: 20px;">Disassembly and Assembly 15</p> <p style="padding-left: 20px;">Inspection 18</p> <p>SERVICE DATA AND SPECIFICATIONS (SDS) 20</p> <p>SERVICE DATA AND SPECIFICATIONS (SDS) 20</p> <p style="padding-left: 20px;">General Specifications 20</p> <p style="padding-left: 20px;">Steering Wheel Axial End Play and Play 20</p> <p style="padding-left: 20px;">Steering Wheel Turning Force 20</p> <p style="padding-left: 20px;">Steering Angle 20</p> <p style="padding-left: 20px;">Steering Column Operating Range 20</p> <p style="padding-left: 20px;">Rack Stroke 20</p> <p style="padding-left: 20px;">Socket Swing Force and Rotating Torque 20</p> <p style="padding-left: 20px;">Socket Axial End Play 21</p> <p style="padding-left: 20px;">Inner Socket Length 21</p>
--	--

NOISE, VIBRATION AND HARSHNESS (NVH) TROUBLESHOOTING

< SYMPTOM DIAGNOSIS >

SYMPTOM DIAGNOSIS

NOISE, VIBRATION AND HARSHNESS (NVH) TROUBLESHOOTING

NVH Troubleshooting Chart

INFOID:000000005037985

Use the chart below to find the cause of the symptom. If necessary, repair or replace these parts.

Symptom		Possible cause and SUSPECTED PARTS	Reference															
			ST-18, "Inspection"	ST-18, "Inspection"	ST-18, "Inspection"	ST-7, "Inspection"	ST-7, "Inspection"	—	ST-14, "Exploded View"	ST-12, "Inspection"	ST-11, "Exploded View"	ST-14, "Exploded View"	NVH in FAX, RAX, FSU, RSU section	NVH in WT section	NVH in WT section	NVH in FAX section	NVH in BR section	
Steering	Noise	Outer/inner socket ball joint swinging torque	×	×	×	×				×	×		×	×	×	×	×	×
	Shake	Outer/inner socket ball joint rotating torque					×	×	×				×	×	×	×	×	×
	Vibration	Outer/inner socket ball joint end play								×	×		×	×				
	Shimmy	Steering wheel play					×		×			×	×	×	×			×
	Judder	Improper steering wheel																
		Improper installation or looseness of tilt lock lever					×	×										
		Mounting looseness																
		Steering column deformation or damage																
		Improper installation or looseness of steering column																
		Steering linkage looseness																
		AXLE and SUSPENSION																
		TIRE																
		ROAD WHEEL																
		DRIVE SHAFT																
		BRAKE																

×: Applicable

PRECAUTIONS

< PRECAUTION >

PRECAUTION

PRECAUTIONS

Precaution for Supplemental Restraint System (SRS) "AIR BAG" and "SEAT BELT PRE-TENSIONER"

INFOID:000000005153310

The Supplemental Restraint System such as "AIR BAG" and "SEAT BELT PRE-TENSIONER", used along with a front seat belt, helps to reduce the risk or severity of injury to the driver and front passenger for certain types of collision. This system includes seat belt switch inputs and dual stage front air bag modules. The SRS system uses the seat belt switches to determine the front air bag deployment, and may only deploy one front air bag, depending on the severity of a collision and whether the front occupants are belted or unbelted. Information necessary to service the system safely is included in the "SRS AIR BAG" and "SEAT BELT" of this Service Manual.

WARNING:

- To avoid rendering the SRS inoperative, which could increase the risk of personal injury or death in the event of a collision which would result in air bag inflation, all maintenance must be performed by an authorized NISSAN/INFINITI dealer.
- Improper maintenance, including incorrect removal and installation of the SRS, can lead to personal injury caused by unintentional activation of the system. For removal of Spiral Cable and Air Bag Module, see the "SRS AIR BAG".
- Do not use electrical test equipment on any circuit related to the SRS unless instructed to in this Service Manual. SRS wiring harnesses can be identified by yellow and/or orange harnesses or harness connectors.

PRECAUTIONS WHEN USING POWER TOOLS (AIR OR ELECTRIC) AND HAMMERS

WARNING:

- When working near the Air Bag Diagnosis Sensor Unit or other Air Bag System sensors with the ignition ON or engine running, DO NOT use air or electric power tools or strike near the sensor(s) with a hammer. Heavy vibration could activate the sensor(s) and deploy the air bag(s), possibly causing serious injury.
- When using air or electric power tools or hammers, always switch the ignition OFF, disconnect the battery, and wait at least 3 minutes before performing any service.

Precaution Necessary for Steering Wheel Rotation after Battery Disconnect

INFOID:000000005153312

NOTE:

- Before removing and installing any control units, first turn the push-button ignition switch to the LOCK position, then disconnect both battery cables.
- After finishing work, confirm that all control unit connectors are connected properly, then re-connect both battery cables.
- Always use CONSULT-III to perform self-diagnosis as a part of each function inspection after finishing work. If a DTC is detected, perform trouble diagnosis according to self-diagnosis results.

This vehicle is equipped with a push-button ignition switch and a steering lock unit.

If the battery is disconnected or discharged, the steering wheel will lock and cannot be turned.

If turning the steering wheel is required with the battery disconnected or discharged, follow the procedure below before starting the repair operation.

OPERATION PROCEDURE

1. Connect both battery cables.

NOTE:

Supply power using jumper cables if battery is discharged.

2. Turn the push-button ignition switch to ACC position.
(At this time, the steering lock will be released.)
3. Disconnect both battery cables. The steering lock will remain released with both battery cables disconnected and the steering wheel can be turned.
4. Perform the necessary repair operation.

PRECAUTIONS

< PRECAUTION >

5. When the repair work is completed, re-connect both battery cables. With the brake pedal released, turn the push-button ignition switch from ACC position to ON position, then to LOCK position. (The steering wheel will lock when the push-button ignition switch is turned to LOCK position.)
6. Perform self-diagnosis check of all control units using CONSULT-III.

Service Notice or Precautions for Steering System

INFOID:000000005037988

- In case of removing steering gear assembly, make the final tightening with grounded and unloaded vehicle condition, and then check wheel alignment.
- Observe the following precautions when disassembling.
 - Before disassembly, thoroughly clean the outside of the unit.
 - Disassembly should be done in a clean work area. It is important to prevent the internal parts from becoming contaminated by dirt or other foreign matter.
 - For easier and proper assembly, place disassembled parts in order on a parts rack.
 - Use nylon cloth or paper towels to clean the parts; common shop rags can leave lint that might interfere with their operation.
 - Never reuse non-reusable parts.
 - Before assembling, apply the specified grease to the directed parts.

PREPARATION

< PREPARATION >

PREPARATION

PREPARATION

Special Service Tools

INFOID:000000005037989

The actual shapes of Kent-Moore tools may differ from those of special service tools illustrated here.

Tool number (Kent-Moore No.) Tool name	Description
ST3127S000 (J-25765-A) Preload gauge	Inspecting steering column assembly rotating torque, pinion rotating torque and ball joint rotating torque
ST27180001 (J-25726-A) Steering wheel puller	Removing steering wheel
KV48103400 (—) Preload adapter	Inspecting rotating torque
KV40107300 (—) Boot band crimping tool	Installing boot clamp (large diameter)

A
B
C
D
E
F
ST
H
I
J
K
L
M
N
O
P

PREPARATION

< PREPARATION >

Commercial Service Tools

INFOID:000000005037990

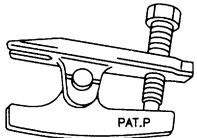
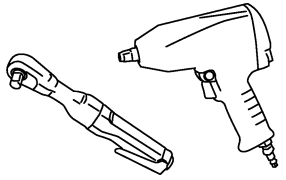
Tool number Tool name	Description
Ball joint remover  S-NT146	Remove steering outer socket
Power tool  PBIC0190E	Loosening bolts and nuts

STEERING WHEEL

< PERIODIC MAINTENANCE >

PERIODIC MAINTENANCE

STEERING WHEEL

Inspection

INFOID:000000005037991

STEERING WHEEL AXIAL END PLAY

1. Check installation conditions of steering gear assembly, front suspension assembly, axle and steering column assembly.
2. Check if movement exists when steering wheel is moved up and down, to the left and right and to the axial direction.

Steering wheel axial end play : Refer to [ST-20, "Steering Wheel Axial End Play and Play"](#).

3. Check the following items when steering wheel axial end play is out of the standard.
 - Check the steering column assembly mounting condition. Refer to [ST-11, "Exploded View"](#).
 - Check steering gear assembly mounting condition for looseness. Refer to [ST-14, "Exploded View"](#).

STEERING WHEEL PLAY

1. Turn steering wheel so that front wheels come to the straight-ahead position.
2. Start engine and lightly turn steering wheel to the left and right until front wheels start to move.
3. Measure steering wheel movement on the outer circumference.

Steering wheel play on the outer circumference : Refer to [ST-20, "Steering Wheel Axial End Play and Play"](#).

4. Check the following items when steering wheel play is out of the standard.
 - Check backlash for each joint of steering column assembly.
 - Check installation condition of steering gear assembly.

NEUTRAL POSITION STEERING WHEEL

1. Make sure that steering gear assembly, steering column assembly and steering wheel are installed in the correct position.
2. Perform neutral position inspection after wheel alignment. Refer to [FSU-7, "Inspection"](#).
3. Set vehicle to the straight-ahead position and confirm steering wheel is in the neutral position.
4. Loosen outer socket lock nut and turn inner socket to left and right equally to make fine adjustments if steering wheel is not in the neutral position.

STEERING WHEEL TURNING FORCE

1. Park vehicle on a level and dry surface, set parking brake.
2. Tires need to be inflated normal pressure. Refer to [WT-97, "Tire Air Pressure"](#).
3. Start engine.
4. Check steering wheel turning force when steering wheel has been turned 360° from neutral position.

Steering wheel turning force : Refer to [ST-20, "Steering Wheel Turning Force"](#).

NOTE:

Multiply the distance (L) from the hook of spring balance to the center of steering wheel by the measurement value with a spring balance.

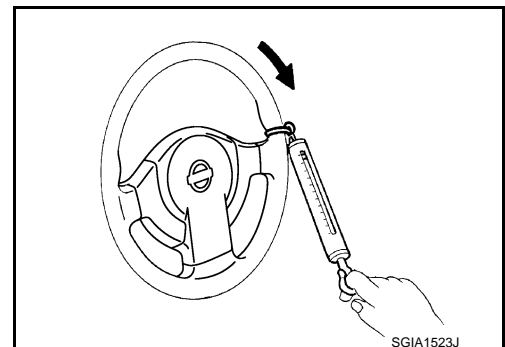

FRONT WHEEL TURNING ANGLE

STEERING WHEEL

< PERIODIC MAINTENANCE >

1. Check front wheel turning angle after toe-in inspection. Refer to [FSU-7, "Inspection"](#).
2. Place front wheels on turning radius gauges and rear wheels on stands, so that vehicle can be level.
3. Check the maximum inner and outer wheel turning angles for LH and RH road wheels.

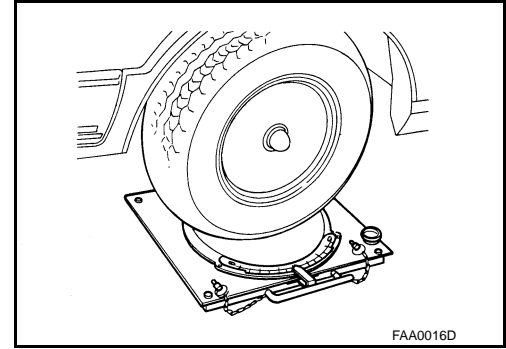

4. With the engine at idle, turn steering wheel from full left stop to full right stop and measure the turning angles.

Inner wheel (Angle: A) : Refer to [ST-20, "Steering Angle"](#).

Outer wheel (Angle: B) : Refer to [ST-20, "Steering Angle"](#).

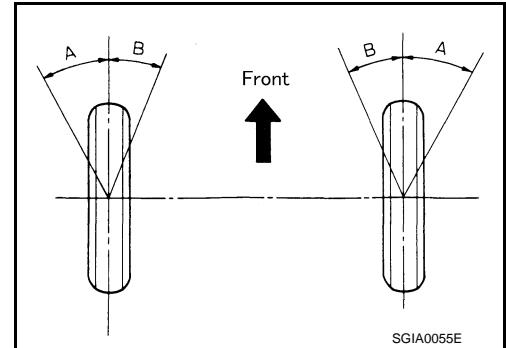

5. Check the following items when turning angle is out of the standard.

- a. Check rack stroke (L).

L : Refer to [ST-20, "Rack Stroke"](#).

- b. Disassemble steering gear assembly to check the cause that rack stroke is outside of the standard.

- Steering angles are not adjustable. Check steering gear assembly, steering column assembly and front suspension components for wear or damage if any of the turning angles are different from the specified value. Replace any of them, if any non-standard condition exists.

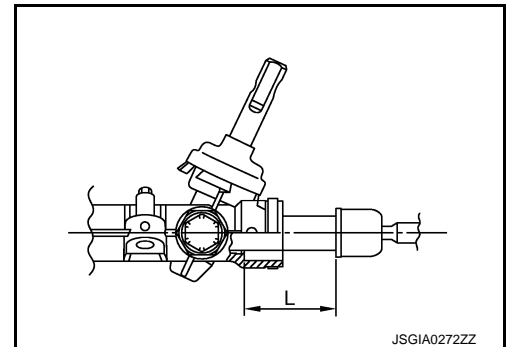

STEERING WHEEL

< REMOVAL AND INSTALLATION >

REMOVAL AND INSTALLATION

STEERING WHEEL

Exploded View

INFOID:000000005037992

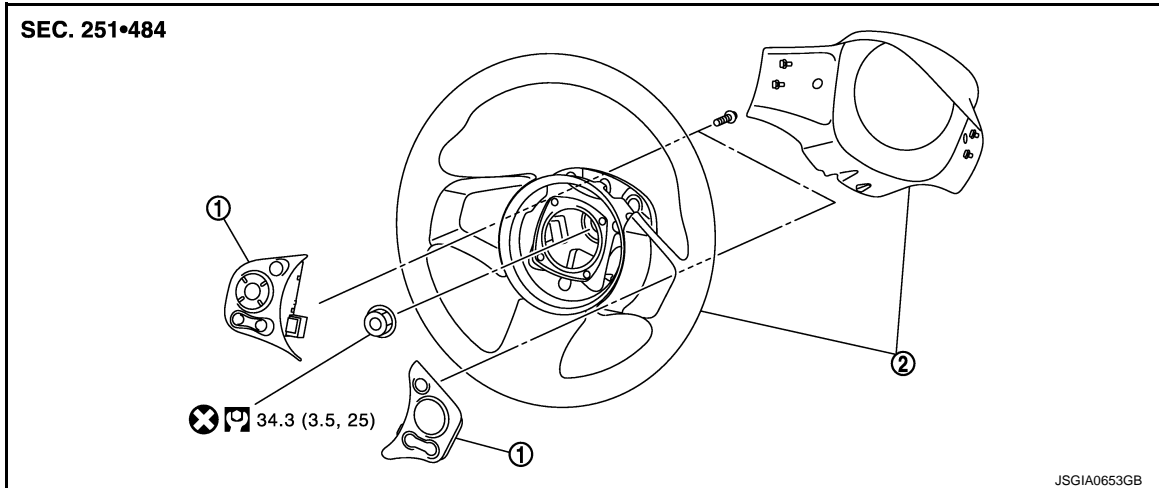

1. Steering switch
2. Steering wheel

Refer to [GI-4, "Components"](#) for symbols in the figure.

Removal and Installation

INFOID:000000005037993

REMOVAL

NOTE:

When reconnecting spiral cable, fix cable with a tape so that fixing case and rotating part keep aligned. This will omit neutral position alignment procedure during spiral cable installation.

1. Set vehicle to the straight-ahead position.
2. Remove driver air bag module. Refer to [SR-5, "Exploded View"](#).
3. Remove steering wheel lock nut after steering is locked.
4. Remove steering wheel with the steering wheel puller (A) [SST: ST27180001 (J-25726-A)].

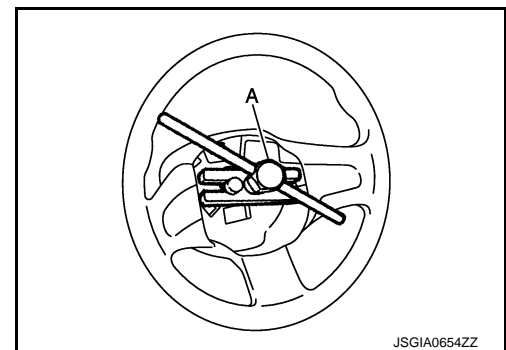

INSTALLATION

Note the following, and install in the reverse order of removal.

CAUTION:

Never twist spiral cable excessively after it becomes tight. (twisting may cause the cable to be torn off.)

NOTE:

Check the spiral cable neutral position after replacing or rotating spiral cable. Refer to [SR-8, "Removal and Installation"](#).

STEERING WHEEL

< REMOVAL AND INSTALLATION >

Disassembly and Assembly

INFOID:000000005038308

DISASSEMBLY

1. Remove steering wheel. Refer to [ST-9, "Exploded View"](#).
2. Remove steering column side cover.
3. Remove steering switch.

ASSEMBLY

Note the following, and install in the reverse order of removal.

- Securely insert the steering switch into the mounting hole of locating bush for the steering wheel.

STEERING COLUMN

< REMOVAL AND INSTALLATION >

STEERING COLUMN

Exploded View

INFOID:000000005037994

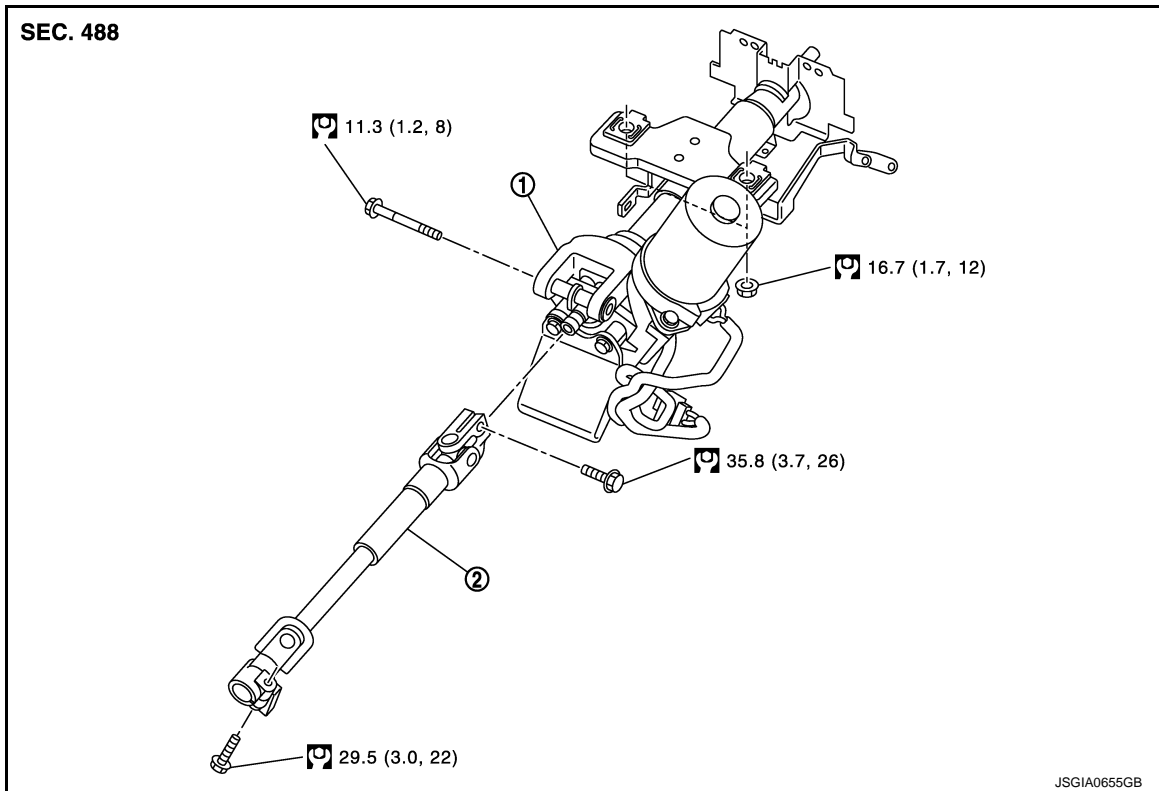

1. Steering column assembly
2. Intermediate shaft

Refer to [GI-4, "Components"](#) for symbols in the figure.

Removal and Installation

INFOID:000000005037995

REMOVAL

CAUTION:

- Never impact on the axis when removing steering column assembly.
- Place a matching mark on both intermediate shaft and steering column assembly before removing intermediate shaft.
- Never repeat static steering. (Motor and EPS control unit could be heated.)
- Be careful when removing steering column assembly from the vehicle because it is heavy.
- Keep steering column assembly away from magnetic sources.
- Never disassemble steering column assembly. It is not separable.

1. Set vehicle to the straight-ahead position.
2. Place the tilt to the lowest level.
3. Remove instrument lower panel LH. Refer to [IP-12, "Exploded View"](#).
4. Remove knee protector.
5. Remove driver air bag module. Refer to [SR-5, "Exploded View"](#).
6. Remove steering wheel. Refer to [ST-9, "Exploded View"](#).
7. Remove steering column cover. Refer to [IP-12, "Exploded View"](#).
8. Remove spiral cable. Refer to [SR-8, "Exploded View"](#).
9. Remove combination switch. Refer to [BCS-83, "Exploded View"](#) (with intelligent key system), [BCS-149, "Exploded View"](#) (without intelligent key system).
10. Disconnect each switch harness connectors installed to steering column assembly.

STEERING COLUMN

< REMOVAL AND INSTALLATION >

11. Remove the joint mounting bolt (steering gear side).
12. Remove steering column assembly.
13. Remove brake pedal. Refer to [BR-17, "Exploded View"](#).
14. Separate the intermediate shaft from steering column assembly.

INSTALLATION

CAUTION:

- **Never impact on the axis when removing steering column assembly.**
- **Be careful when removing steering column assembly from the vehicle because it is heavy.**

Note the following, and install in the reverse order of removal.

- Insert bolt in the proper direction. (Do not insert it from the other side.)
- When connecting intermediate shaft lower side and pinion assembly, make sure the bolt is securely seated in groove of pinion assembly before final tightening.
- When tightening bolt (steering gear assembly side), tighten it by hand first, and make sure there is no feeling of sticking or galling before final tightening.
- When connecting intermediate shaft upper side (1) and column shaft, make sure the bolt is securely seated in groove (A) of column shaft before final tightening.

CAUTION:

- **After installing steering column assembly, perform self-diagnosis with CONSULT-III to ensure correct operation. Refer to [STC-7, "CONSULT-III Function"](#).**
- **Rotate steering wheel to check for decentered condition, binding, noise or excessive steering effort.**
- **Adjust neutral position of steering angle sensor. Refer to [BRC-8, "ADJUSTMENT OF STEERING ANGLE SENSOR NEUTRAL POSITION : Description"](#).**

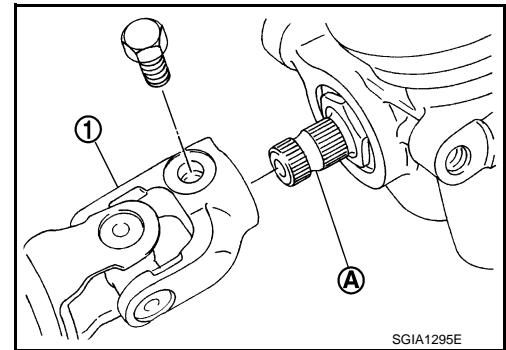

Inspection

INFOID:000000005037996

INSPECTION AFTER REMOVAL

- Check each part of steering column assembly for damage or other malfunctions. Replace if there are any abnormal conditions.
- Measure steering column assembly rotating torque using a preload gauge [SST: ST3127S000 (J-25765-A)]. Replace steering column assembly if the rotating torque is outside the standard.

Rotating torque : Refer to [ST-20, "Steering Column Operating Range"](#).

- Measure the length "L" shown in the figure, if vehicle has been involved in a minor collision. Replace steering column assembly (with motor, reduction gear, sensor) if "L" is outside the standard.

L : Refer to [ST-20, "Steering Column Operating Range"](#).

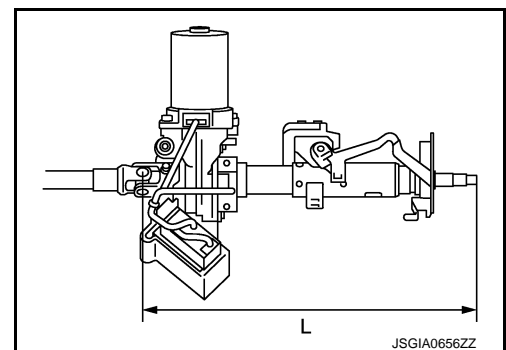

INSPECTION AFTER INSTALLATION

- Check each part of steering column assembly for damage or other malfunctions. Replace if there are any abnormal conditions.
- Check the steering wheel play, neutral position steering wheel, steering wheel turning force, and front wheel turning angle. Refer to [ST-7, "Inspection"](#).

STEERING COLUMN

< REMOVAL AND INSTALLATION >

- Check tilt mechanism operating range "T" shown in the figure.

T

: Refer to [ST-20. "Steering Column Operating Range"](#).

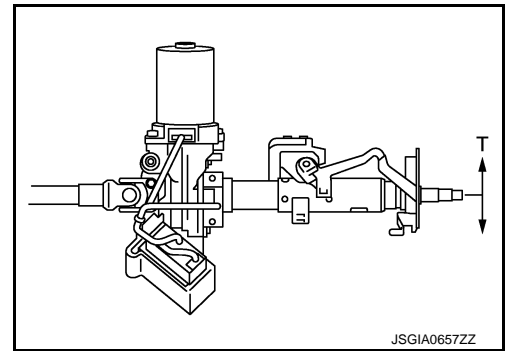

A

B

C

D

E

F

ST

H

I

J

K

L

M

N

O

P

STEERING GEAR AND LINKAGE

< REMOVAL AND INSTALLATION >

STEERING GEAR AND LINKAGE

Exploded View

INFOID:000000005037997

REMOVAL

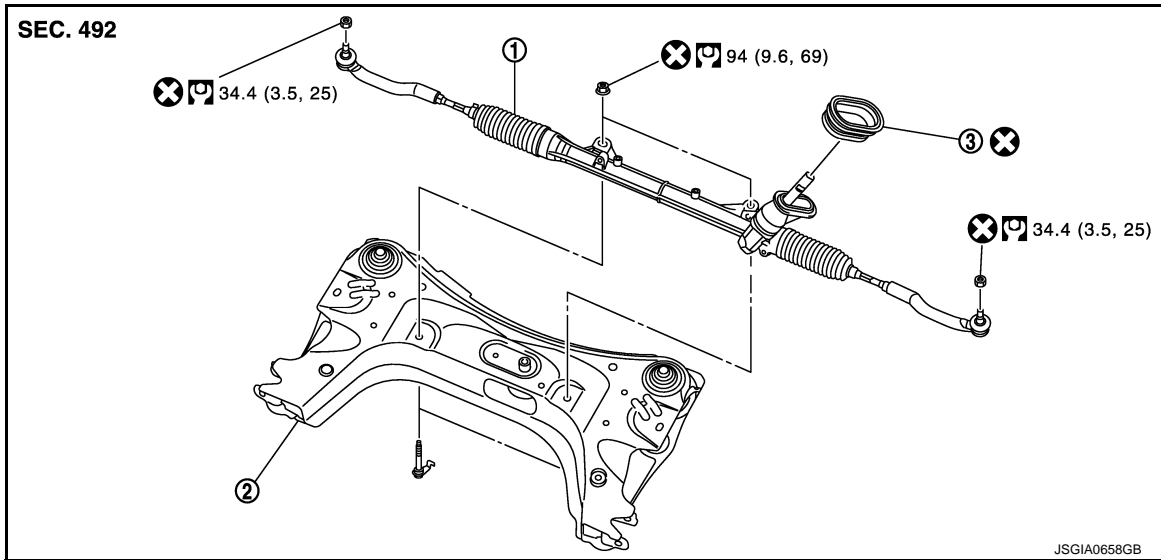

- 1. Steering gear assembly
- 2. Front suspension member
- 3. Fire wall seal

←: Vehicle front

Refer to [GI-4. "Components"](#) for symbols in the figure.

DISASSEMBLY

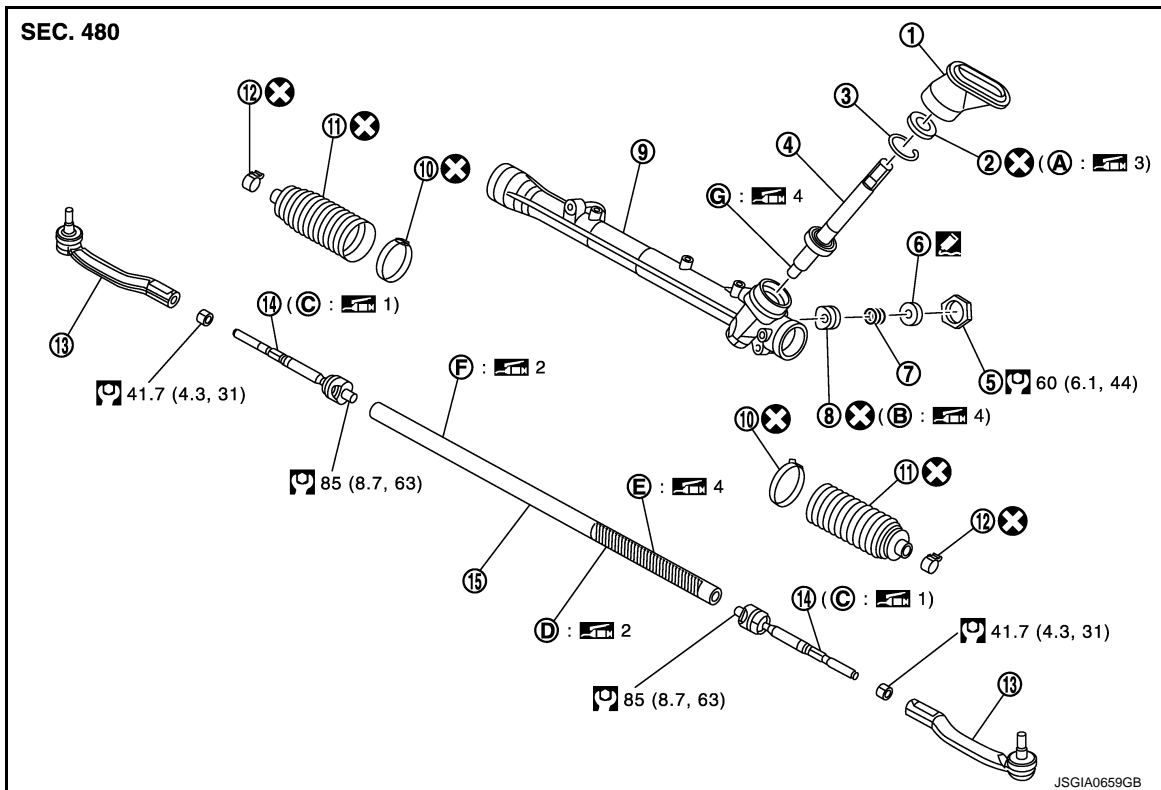

STEERING GEAR AND LINKAGE

< REMOVAL AND INSTALLATION >

- | | | | |
|---------------------------------|--------------------------|---------------------------------|---|
| 1. Joint cover | 2. Dust cover | 3. Snap ring | A |
| 4. Pinion assembly | 5. Lock nut | 6. Adjusting screw | |
| 7. Spring | 8. Retainer | 9. Gear housing assembly | |
| 10. Boot clamp (large diameter) | 11. Boot | 12. Boot clamp (small diameter) | B |
| 13. Outer socket | 14. Inner socket | 15. Rack assembly | |
| A. Oil seal lip | B. Around retainer | C. Inner socket | |
| D. Teeth part of rack assembly | E. back of rack assembly | F. Bush part of rack assembly | C |
| G. Needle bearing | | | |

1: Apply Genuine Lithium Soap, Autorex A (manufactured by Kyoudouyushi) or equivalent.

2: Apply Genuine Lithium Soap, Wanlouver MO No.2 (manufactured by Kyoudouyushi) or equivalent.

3: Apply Genuine Lithium Soap, Idemitsu Autorex A or equivalent.

4: Apply Genuine Lithium Soap, Multemp AC-P (manufactured by Kyoudouyushi) or equivalent.

: Apply Genuine Thread Locking Sealant, Three Bond 1141 or equivalent.

Refer to [GI-4, "Components"](#) and the followings for the symbols in the figure.

Removal and Installation

INFOID:000000005037998

REMOVAL

1. Set vehicle to the straight-ahead position.
2. Remove bolt intermediate shaft (steering gear assembly side). Refer to [ST-11, "Exploded View"](#).
CAUTION:
Spiral cable may be cut if steering wheel turns while separating steering column assembly and steering gear assembly. Always fix the steering wheel using string to avoid.
3. Remove tires with a power tool. Refer to [WT-91, "Exploded View"](#).
4. Remove steering outer socket from steering knuckle so as not to damage ball joint boot using suitable ball joint remover (commercial service tool).
CAUTION:
Temporarily tighten the nut to prevent damage to threads and to prevent the ball joint remover from sudden drop turning.
5. Remove front stabilizer connecting rod. Refer to [FSU-14, "Exploded View"](#).
6. Support front suspension member with a suitable jack.
7. Remove rear torque and engine mounting bracket mounting bolts. Refer to [EM-74, "Exploded View"](#).
8. Remove the mounting bolts and nuts of steering gear assembly.
9. Remove member stay, front suspension member fixing bolts. Refer to [FSU-16, "Exploded View"](#).
10. Lower the suitable jack for the front suspension member to the steering gear assembly can be removed.

INSTALLATION

Note the following, and install in the reverse order of removal.

CAUTION:

Spiral cable may be cut if steering wheel turns while separating steering column assembly and steering gear assembly. Always fix the steering wheel using string to avoid turning.

- Clean mounting surface on the body side of fire wall seal when installing steering gear assembly.
- Perform final tightening of nuts and bolts on each part under unladen conditions with tires on level ground when removing steering gear assembly. Check wheel alignment. Refer to [FSU-7, "Inspection"](#).
- Rotate steering wheel to check for decentered condition, binding, noise or excessive steering effort.
- Adjust neutral position of steering angle sensor after checking wheel alignment. Refer to [BRC-8, "ADJUSTMENT OF STEERING ANGLE SENSOR NEUTRAL POSITION : Description"](#).

Disassembly and Assembly

INFOID:000000005037999

DISASSEMBLY

CAUTION:

- Disassemble and assemble steering gear assembly by fixing the mounting area with a vise using copper plates.

STEERING GEAR AND LINKAGE

< REMOVAL AND INSTALLATION >

- Clean steering gear assembly with kerosene before disassembling. Be careful to avoid splashing or applying any kerosene over connector of discharge port or return port.

1. Loosen outer socket lock nut, and remove outer socket.

CAUTION:

When loosening lock nut, be sure to fix outer socket with a wrench or an equivalent to prevent ball joint from getting contact with knuckle.

2. Remove boot clamps, and then remove boot from inner socket.

CAUTION:

Never damage inner socket and gear housing assembly when removing boot. Inner socket and gear housing assembly must be replaced if inner socket and gear housing assembly are damaged because it may cause foreign material interfusion.

3. Remove inner socket from gear housing assembly.

4. Measure adjusting screw (1) height "H", and loosen adjusting screw.

CAUTION:

- Never loosen adjusting screw 2 turns or more.
- Replace steering gear assembly if adjusting screw is loosened 2 turns or more and it is removed.

5. Remove lock nut (2), adjusting screw, spring (4) and retainer (3) from gear housing assembly (5).

6. Remove joint cover from gear housing assembly.

CAUTION:

Never damage the locating protrusion of the joint cover.

7. Remove dust cover from pinion assembly.

8. Remove snap ring, and then remove pinion assembly from gear housing assembly.

9. Pull pinion assembly from gear housing assembly.

CAUTION:

Never damage pinion assembly and gear housing assembly inner wall.

10. Pull rack assembly from gear housing assembly.

CAUTION:

Never damage rack assembly and gear housing assembly inner wall.

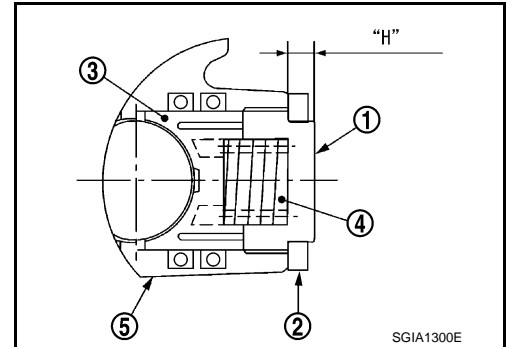

ASSEMBLY

1. Apply recommended grease to teeth part and bush part of rack assembly, if necessary.

Use Genuine Lithium Soap, Wanlouver MO No.2 (manufactured by kyoudouyushi) or equivalent.

2. Apply recommended grease to back of rack assembly, if necessary.

Use Genuine Lithium Soap, Multemp AC-P (manufactured by kyoudouyushi) or equivalent.

3. Install rack assembly to gear housing assembly.

CAUTION:

Never damage rack assembly and gear housing assembly inner wall.

4. Apply recommended grease to pinion assembly needle bearing, if necessary.

Use Genuine Lithium Soap, Multemp AC-P (manufactured by kyoudouyushi) or equivalent.

5. Install pinion assembly to gear housing assembly.

6. Install snap ring to pinion assembly.

CAUTION:

- Never reuse snap ring.
- When installing snap ring, check that the chamfered surface faces upward.

7. Install inner socket to rack assembly.

8. Apply recommended grease to dust cover, and then install dust cover to pinion assembly.

Use Genuine Lithium Soap, Idemitsu Autorex A or equivalent.

STEERING GEAR AND LINKAGE

< REMOVAL AND INSTALLATION >

9. Decide on the neutral position for the rack stroke (L).

L

: Refer to [ST-20, "Rack Stroke"](#).

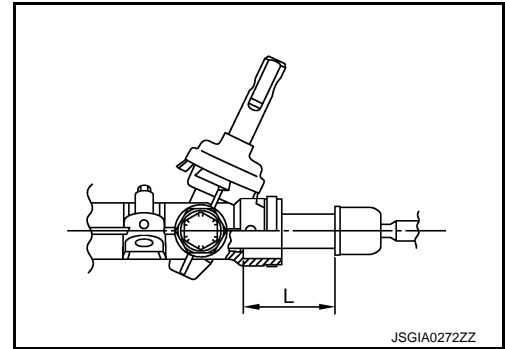

10. Apply recommended grease to around retainer (3), then install retainer, spring (4) and adjusting screw (1) to gear housing assembly (5).

Use Genuine Lithium Soap, Multemp AC-P (manufactured by kyoudouyushi) or equivalent.

11. Apply recommended thread locking sealant to the thread (2 turns thread), and then screw in the adjusting screw until it reaches height "H" from gear housing assembly measured before disassembling.

Use Genuine Thread Locking Sealant, Three Bond 1141 or equivalent.

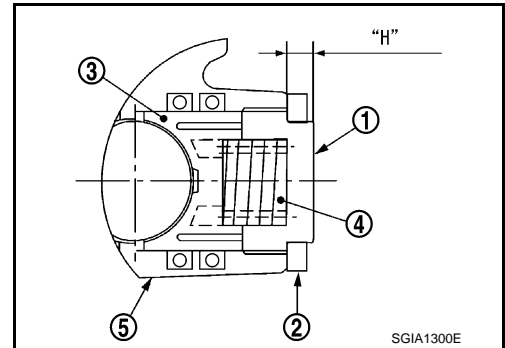

12. Tighten lock nut to (2) the specified torque securing it to prevent adjusting screw from freewheeling condition.

13. Move rack assembly 10 strokes throughout the full stroke so that the parts can fit with each other.

14. Using preload gauge (A) [SST: ST3127S000 (J-25765-A)] and preload adapter (B) [SST: KV48103400 (—)], measure rotating torque of pinion assembly. If the measurement is outside of the specified range, readjust pinion rotating torque. If the measurement is outside of the specified range for readjust, replace steering gear assembly.

Pinion rotating torque

Around neutral position (within ±100°) Average A **0.6 - 1.2 N·m (0.07 - 0.12 kg-m, 6 - 10 in-lb)**

Maximum variation C **1.6 N·m (0.16 kg-m, 14 in-lb)**

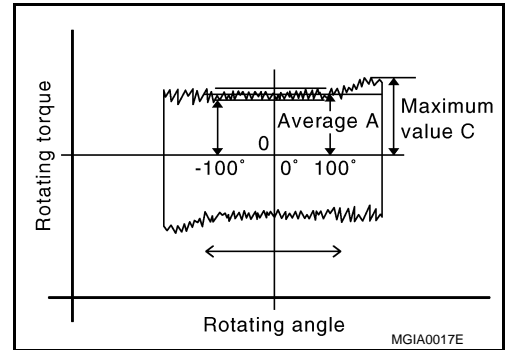

15. Set dial gauge to the back of rack assembly on the pinion assembly side around the center of stroke. Measure displacement of rack under torsional torque of ± 7.8 N·m (0.80 kg-m, 69 in-lb), and then check if it is within the standard value. If the measurement is outside the standard value, adjust it again. After the readjustment, if measurement is still outside the standard value, replace steering gear assembly.

Standard value : 0.1 mm (0.004 in) or less

16. Apply recommended grease to inner socket, and then install boot to gear housing assembly and inner socket.

Use Genuine Lithium Soap, Idemitsu Autorex A or equivalent.

CAUTION:

Never reuse boot.

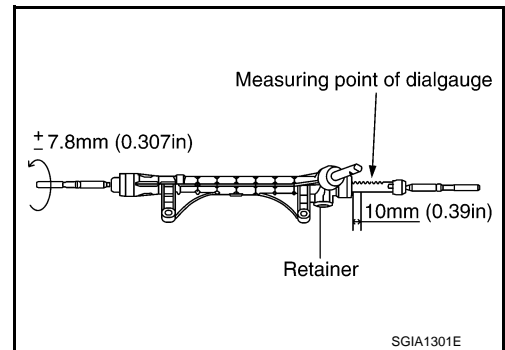

STEERING GEAR AND LINKAGE

< REMOVAL AND INSTALLATION >

17. Install boot clamp (large diameter) (1) to boot using boot band crimping tool [SST: KV40107300 (—)].

CAUTION:

- Never reuse boot clamp (large diameter).
- Install boot clamp (large diameter) (1) securely to boot groove, and crimp it so as to have clearance of 3 mm (0.12 in) or less as shown.

18. Install boot clamp (small diameter) to boot.

CAUTION:

- Never reuse boot clamp (small diameter).

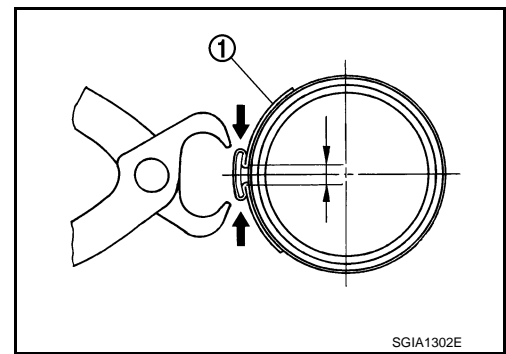

19. Install joint cover (1) to gear housing assembly (2).

CAUTION:

- Install joint cover so that the protrusion for locating is securely set to gear housing groove.

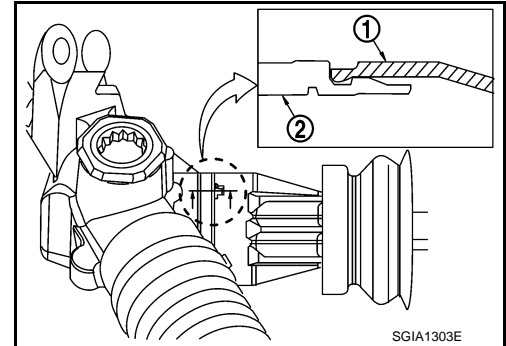

20. Adjust inner socket to standard length (L), and then tighten lock nut to the specified torque. Check length again after tightening lock nut.

L

: Refer to [ST-21, "Inner Socket Length"](#).

CAUTION:

- When tightening lock nut, be sure to fix outer socket with a wrench or equivalent to prevent ball joint from getting contact with knuckle.
- Adjust toe-in. Refer to [FSU-7, "Inspection"](#). Length achieved after toe-in adjustment is not necessarily the above value.

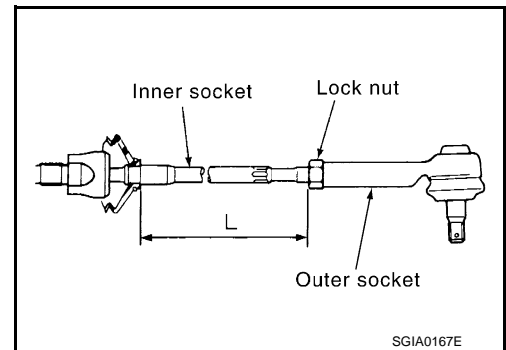

Inspection

INFOID:000000005038000

INSPECTION AFTER INSTALLATION

- Check if steering wheel turns smoothly when it is turned several times fully to the end of the left and right.
- Check the steering wheel play, neutral position steering wheel, steering wheel turning force, and front wheel turning angle. Refer to [ST-7, "Inspection"](#).

INSPECTION AFTER DISASSEMBLY

Boot

- Check boot for cracks, and replace it if a malfunction is detected.

Gear Housing Assembly

- Check gear housing assembly for damage and scratches (inner wall). Replace if there are any abnormal conditions.

Outer Socket and Inner Socket

- Check the following items and replace the component if it does not meet the standard.

BALL JOINT SWINGING TORQUE

STEERING GEAR AND LINKAGE

< REMOVAL AND INSTALLATION >

- Hook a spring balance at the point shown in the figure and pull the spring balance. Make sure that the spring balance reads the specified value when ball stud and inner socket start to move. Replace outer socket and inner socket if they are outside the standard.

(Measuring point of outer socket: Ball stud upper side)

Outer socket : Refer to [ST-20, "Socket Swing Force and Rotating Torque"](#).

(Measuring point of inner socket: "*" mark shown in the figure)

Inner socket : Refer to [ST-20, "Socket Swing Force and Rotating Torque"](#).

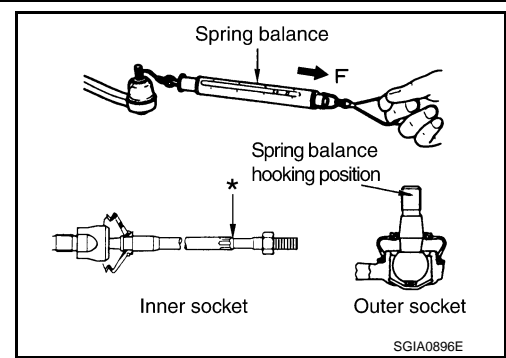

BALL JOINT AXIAL END PLAY

- Apply an axial load of 490 N (50 kg, 110 lb) to ball stud. Using a dial gauge, measure amount of stud movement, and then make sure that the value is within the following specified range. Replace outer socket (1) and inner socket (2) if the measured value is outside the standard.

Outer socket : Refer to [ST-21, "Socket Axial End Play"](#).

Inner socket : Refer to [ST-21, "Socket Axial End Play"](#).

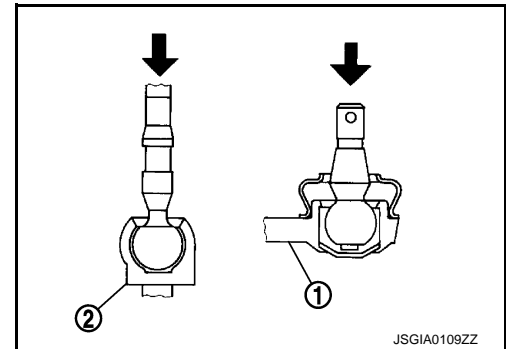

A
B
C
D
E
F
ST
H
I
J
K
L
M
N
O
P

SERVICE DATA AND SPECIFICATIONS (SDS)

< SERVICE DATA AND SPECIFICATIONS (SDS)

SERVICE DATA AND SPECIFICATIONS (SDS)

SERVICE DATA AND SPECIFICATIONS (SDS)

General Specifications

INFOID:000000005038001

Steering gear model	R24K
---------------------	------

Steering Wheel Axial End Play and Play

INFOID:000000005038002

Unit: mm (in)

Item	Standard
Steering wheel axial end play	0 (0)
Steering wheel play on the outer circumference	0 - 35 (0 - 1.38)

Steering Wheel Turning Force

INFOID:000000005038003

Unit: N (kg-f, lb-f)

Item	Standard
Steering wheel turning force	36 (3.7, 8.09) or less

Steering Angle

INFOID:000000005038004

Unit: Degree minute (Decimal degree)

Item		Standard	
		Wheel size: 15 inch	Wheel size: 16 inch
Inner wheel	Minimum	35°00' (35.0°)	
	Nominal	38°00' (38.0°)	
	Maximum	39°00' (39.0°)	
Outer wheel	Nominal	33°00' (33.0°)	

Steering Column Operating Range

INFOID:000000005038005

Tilt operating range	40 mm (1.57 in)
Rotating torque	0 – 2.1 N·m (0 – 0.21 kg-m, 0 – 2 in-lb)
Steering column length	458.1 – 462.1 mm (18.04 – 18.19 in)

Rack Stroke

INFOID:000000005038006

Unit: mm (in)

Item	Standard
Rack stroke neutral position	65.0 (2.56)

Socket Swing Force and Rotating Torque

INFOID:000000005038007

Item		Spring balance
Outer socket	Swinging torque	0.3 – 2.9 N·m (0.03 – 0.30 kg-m, 3 – 26 in-lb)
	Spring balance measurement	6.0 – 58 N (0.61 – 5.9 kg-f, 1.35 – 13.03 lb-f)
Inner socket	Swinging torque	0.5 – 5.0 N·m (0.05 – 0.51 kg-m, 4 – 44 in-lb)
	Spring balance measurement	4.3 – 43.5 N (0.44 – 4.4 kg-f, 0.97 – 9.77 lb-f)

SERVICE DATA AND SPECIFICATIONS (SDS)

< SERVICE DATA AND SPECIFICATIONS (SDS)

Socket Axial End Play

INFOID:000000005038008

Item	Standard
Outer socket	0.5 mm (0.020 in) or less
Inner socket	0.2 mm (0.008 in) or less

Inner Socket Length

INFOID:000000005038009

Unit: mm (in)

Item	Standard
Rack neutral position, dimension	57.8 (2.276)

A

B

C

D

E

F

ST

H

I

J

K

L

M

N

O

P