

SECTION **VTL**
VENTILATION SYSTEM

A
 B
 C
 D
 E
 F
 G
 H
 I
VTL
 J
 K
 L
 M
 N
 O
 P

CONTENTS

SYSTEM DESCRIPTION	2	SIDE VENTILATOR GRILLE	8
VENTILATION SYSTEM	2	SIDE VENTILATOR GRILLE : Removal and Installation	8
System Description	2	CENTER VENTILATOR DUCT	9
PRECAUTION	3	CENTER VENTILATOR DUCT : Removal and Installation	9
PRECAUTIONS	3	SIDE VENTILATOR DUCT	9
Precaution for Supplemental Restraint System (SRS) "AIR BAG" and "SEAT BELT PRE-TENSIONER"	3	SIDE VENTILATOR DUCT : Removal and Installation	9
Precaution Necessary for Steering Wheel Rotation after Battery Disconnect	3	FRONT DEFROSTER NOZZLE	9
PREPARATION	5	FRONT DEFROSTER NOZZLE : Removal and Installation	9
PREPARATION	5	SIDE DEFROSTER NOZZLE	10
Commercial Service Tool	5	SIDE DEFROSTER NOZZLE : Removal and Installation	10
PERIODIC MAINTENANCE	6	REAR FOOT DUCT 1	10
IN-CABIN MICROFILTER	6	REAR FOOT DUCT 1 : Removal and Installation....	10
Exploded View	6	REAR FOOT DUCT 2	10
Removal and Installation	6	REAR FOOT DUCT 2 : Removal and Installation....	11
Replacement	6	FOOT DUCT	11
REMOVAL AND INSTALLATION	7	FOOT DUCT : Removal and Installation	11
DUCT AND GRILLE	7	BLOWER MOTOR	13
Exploded View	7	Exploded View	13
CENTER VENTILATOR GRILLE	8	Removal and Installation	13
CENTER VENTILATOR GRILLE : Removal and Installation	8		

VENTILATION SYSTEM

< SYSTEM DESCRIPTION >

SYSTEM DESCRIPTION

VENTILATION SYSTEM

System Description

INFOID:000000004907718

OUTLINE

Ventilation system is controlled by A/C auto amp. (AUTOMATIC AIR CONDITIONER) or A/C control (MANUAL AIR CONDITIONER and MANUAL HEATER). For details of air conditioner system, refer to [HAC-16. "System Description"](#) (AUTOMATIC AIR CONDITIONER), [HAC-162. "System Description"](#) (MANUAL AIR CONDITIONER) or [HAC-235. "System Description"](#) (MANUAL HEATER).

AIR FLOW

Front

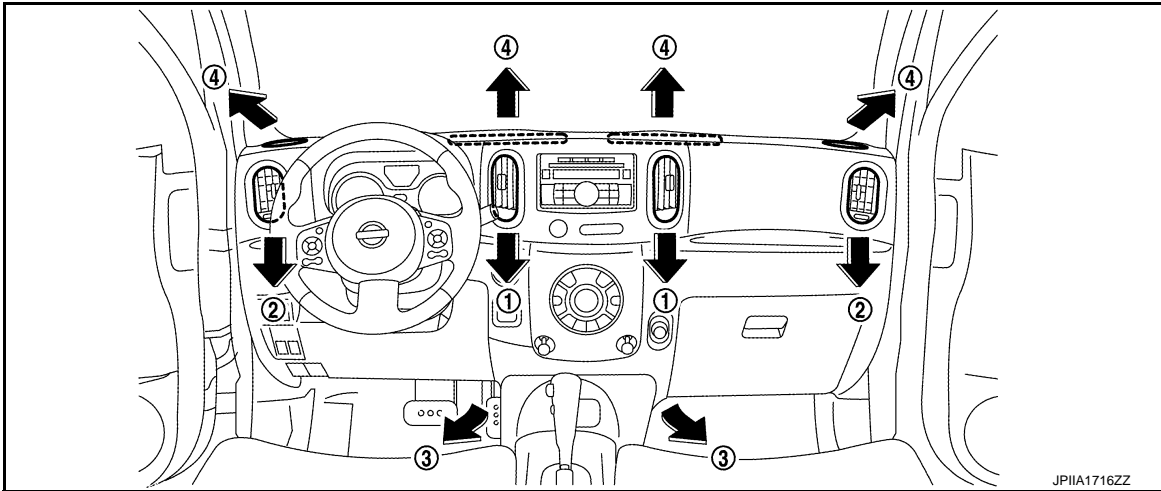

Rear

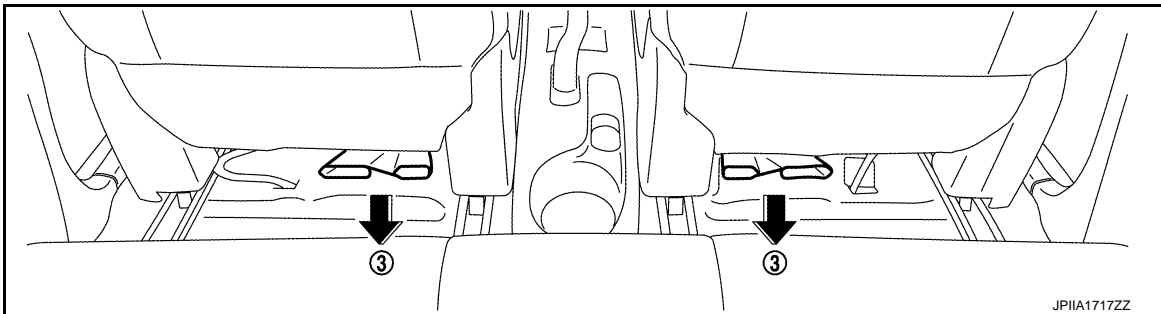

×: Applicable

MODE/DEF position indication	AIR OUTLET			
	Ventilator (1)	Ventilator (2)	Foot (3)	Defroster (4)
	×	×	—	—
	×	×	×	—
	—	×	×	×
	—	×	×	×
	—	×	—	×

PRECAUTIONS

< PRECAUTION >

PRECAUTION

PRECAUTIONS

Precaution for Supplemental Restraint System (SRS) "AIR BAG" and "SEAT BELT PRE-TENSIONER"

INFOID:000000005044309

The Supplemental Restraint System such as "AIR BAG" and "SEAT BELT PRE-TENSIONER", used along with a front seat belt, helps to reduce the risk or severity of injury to the driver and front passenger for certain types of collision. This system includes seat belt switch inputs and dual stage front air bag modules. The SRS system uses the seat belt switches to determine the front air bag deployment, and may only deploy one front air bag, depending on the severity of a collision and whether the front occupants are belted or unbelted. Information necessary to service the system safely is included in the "SRS AIR BAG" and "SEAT BELT" of this Service Manual.

WARNING:

- To avoid rendering the SRS inoperative, which could increase the risk of personal injury or death in the event of a collision which would result in air bag inflation, all maintenance must be performed by an authorized NISSAN/INFINITI dealer.
- Improper maintenance, including incorrect removal and installation of the SRS, can lead to personal injury caused by unintentional activation of the system. For removal of Spiral Cable and Air Bag Module, see the "SRS AIR BAG".
- Do not use electrical test equipment on any circuit related to the SRS unless instructed to in this Service Manual. SRS wiring harnesses can be identified by yellow and/or orange harnesses or harness connectors.

PRECAUTIONS WHEN USING POWER TOOLS (AIR OR ELECTRIC) AND HAMMERS

WARNING:

- When working near the Air Bag Diagnosis Sensor Unit or other Air Bag System sensors with the ignition ON or engine running, DO NOT use air or electric power tools or strike near the sensor(s) with a hammer. Heavy vibration could activate the sensor(s) and deploy the air bag(s), possibly causing serious injury.
- When using air or electric power tools or hammers, always switch the ignition OFF, disconnect the battery, and wait at least 3 minutes before performing any service.

Precaution Necessary for Steering Wheel Rotation after Battery Disconnect

INFOID:000000005044311

NOTE:

- Before removing and installing any control units, first turn the push-button ignition switch to the LOCK position, then disconnect both battery cables.
- After finishing work, confirm that all control unit connectors are connected properly, then re-connect both battery cables.
- Always use CONSULT-III to perform self-diagnosis as a part of each function inspection after finishing work. If a DTC is detected, perform trouble diagnosis according to self-diagnosis results.

This vehicle is equipped with a push-button ignition switch and a steering lock unit.

If the battery is disconnected or discharged, the steering wheel will lock and cannot be turned.

If turning the steering wheel is required with the battery disconnected or discharged, follow the procedure below before starting the repair operation.

OPERATION PROCEDURE

1. Connect both battery cables.

NOTE:

Supply power using jumper cables if battery is discharged.

2. Turn the push-button ignition switch to ACC position.
(At this time, the steering lock will be released.)
3. Disconnect both battery cables. The steering lock will remain released with both battery cables disconnected and the steering wheel can be turned.
4. Perform the necessary repair operation.

PRECAUTIONS

< PRECAUTION >

5. When the repair work is completed, re-connect both battery cables. With the brake pedal released, turn the push-button ignition switch from ACC position to ON position, then to LOCK position. (The steering wheel will lock when the push-button ignition switch is turned to LOCK position.)
6. Perform self-diagnosis check of all control units using CONSULT-III.

PREPARATION

< PREPARATION >

PREPARATION

PREPARATION

Commercial Service Tool

INFOID:000000004907722

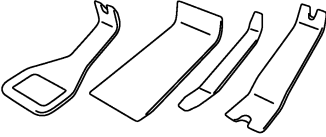
Tool name	Description
Remover tool  PIIB7923J	Remove clips, pawls, metal clips

A
B
C
D
E
F
G
H
VTL
J
K
L
M
N
O
P

VTL

IN-CABIN MICROFILTER

< PERIODIC MAINTENANCE >

PERIODIC MAINTENANCE

IN-CABIN MICROFILTER

Exploded View

INFOID:000000004907737

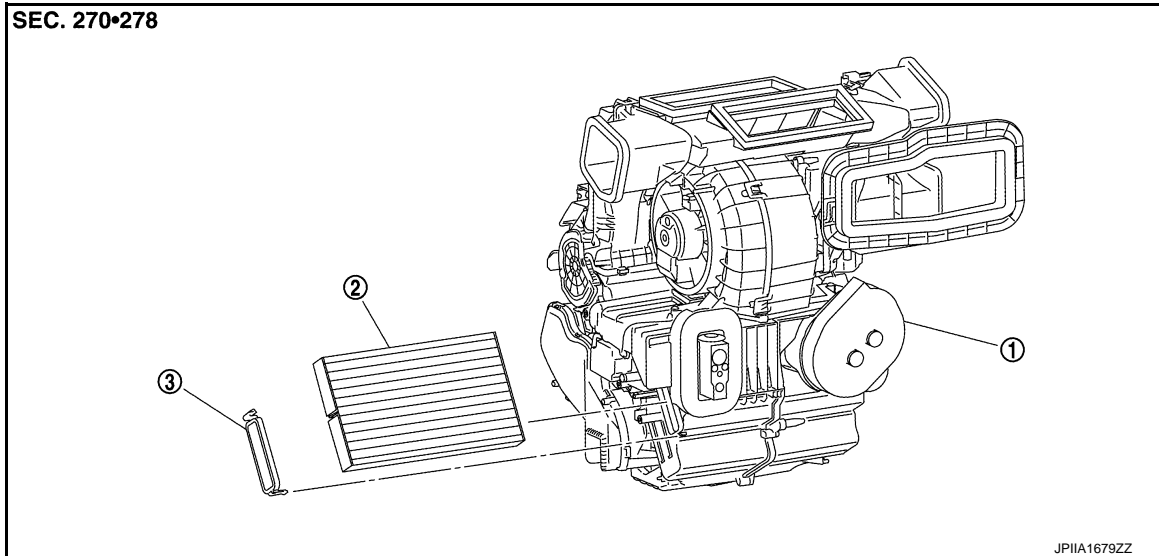

1. A/C unit assembly

2. In-cabin microfilter

3. Filter cover

Removal and Installation

INFOID:000000004907738

REMOVAL

1. Remove globe box assembly. Refer to [IP-12, "Exploded View"](#).
2. Remove filter cover (1) from the RH side of A/C unit assembly, and then remove in-cabin microfilter (2).

CAUTION:

If the filter is deformed/damaged when removing, replace it with a new one. Deformed/damaged filter may deteriorate the dust collecting performance.

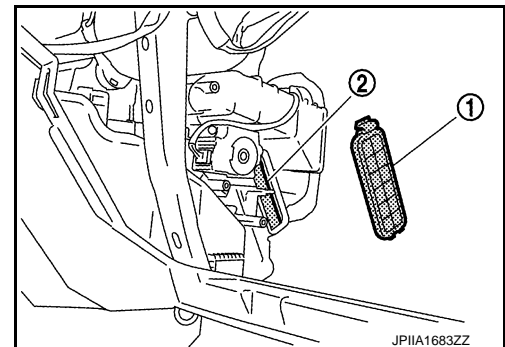

INSTALLATION

Installation is basically the reverse order of removal.

CAUTION:

When installing, handle the filter with extreme care to avoid deforming/damaging.

Replacement

INFOID:000000004907739

Replace in-cabin microfilter.

Refer to [MA-6, "Schedule 1"](#) and [MA-8, "Schedule 2"](#).

Affix a caution label inside the glove box when replacing filter.

DUCT AND GRILLE

< REMOVAL AND INSTALLATION >

REMOVAL AND INSTALLATION

DUCT AND GRILLE

Exploded View

INFOID:000000004907723

FRONT

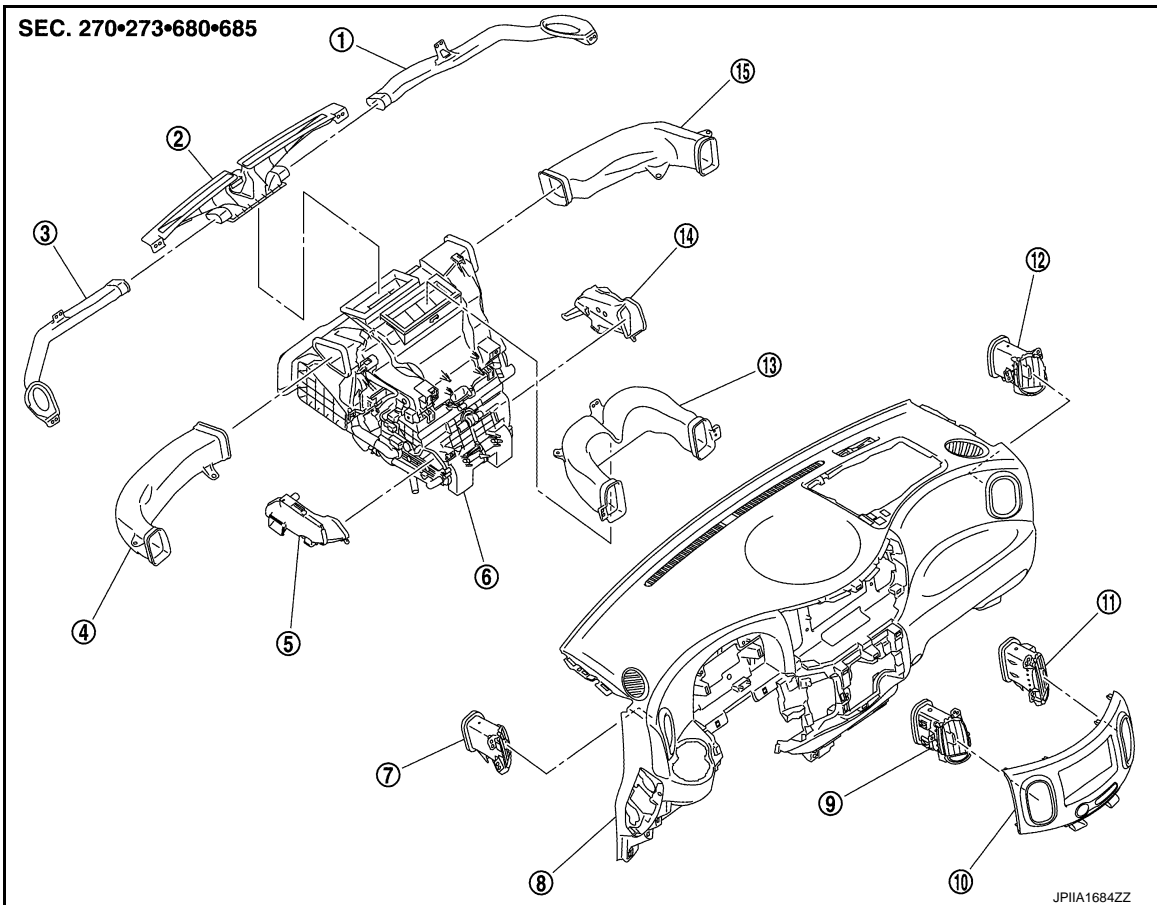

- | | | |
|------------------------------|---------------------------------|--------------------------------|
| 1. Side defroster nozzle RH | 2. Front defroster nozzle | 3. Side defroster nozzle LH |
| 4. Side ventilator duct LH | 5. Foot duct LH | 6. A/C unit assembly |
| 7. Side ventilator grille LH | 8. Instrument panel assembly | 9. Center ventilator grille LH |
| 10. Cluster lid C | 11. Center ventilator grille RH | 12. Side ventilator grille RH |
| 13. Center ventilator duct | 14. Foot duct RH | 15. Side ventilator duct RH |

REAR

A
B
C
D
E
F
G
H
VTL
J
K
L
M
N
O
P

DUCT AND GRILLE

< REMOVAL AND INSTALLATION >

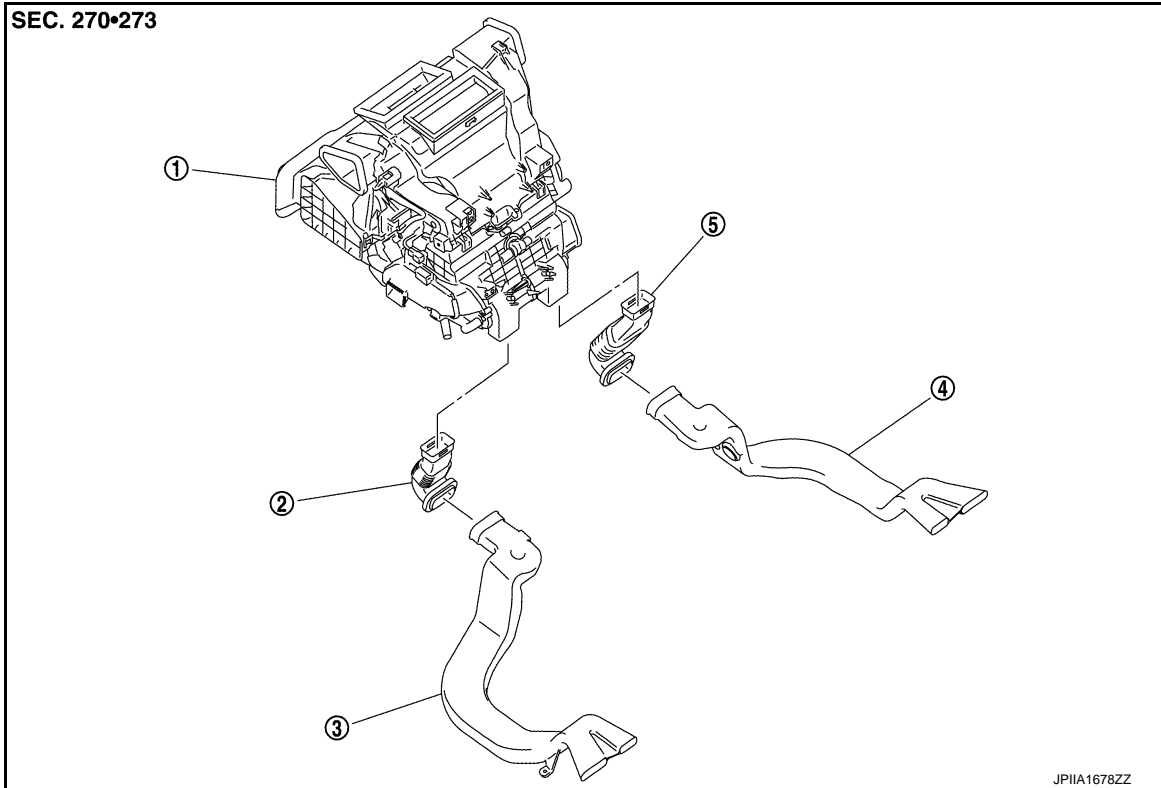

- | | | |
|------------------------|------------------------|------------------------|
| 1. A/C unit assembly | 2. Rear foot duct 1 LH | 3. Rear foot duct 2 LH |
| 4. Rear foot duct 2 RH | 5. Rear foot duct 1 RH | |

CENTER VENTILATOR GRILLE

CENTER VENTILATOR GRILLE : Removal and Installation

INFOID:000000004907724

REMOVAL

1. Remove cluster lid C. Refer to [IP-12. "Exploded View"](#).
2. Remove mounting screws, and then remove center ventilator grille from cluster lid C.

INSTALLATION

Installation is basically the reverse order of removal.

SIDE VENTILATOR GRILLE

SIDE VENTILATOR GRILLE : Removal and Installation

INFOID:000000004907725

REMOVAL

1. Remove instrument panel assembly. Refer to [IP-12. "Exploded View"](#).
2. Remove mounting screws (A), and then remove side ventilator grille (1) from instrument panel assembly.

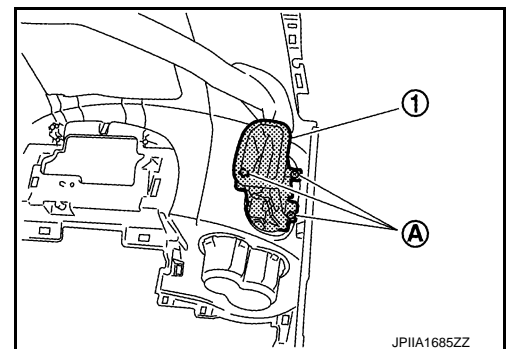

INSTALLATION

DUCT AND GRILLE

< REMOVAL AND INSTALLATION >

Installation is basically the reverse order of removal.

CENTER VENTILATOR DUCT

CENTER VENTILATOR DUCT : Removal and Installation

INFOID:000000004907728

REMOVAL

1. Remove front defroster nozzle. Refer to [VTL-7, "Exploded View"](#).
2. Remove mounting screws (A), and then remove center ventilator duct (1) from instrument panel assembly.

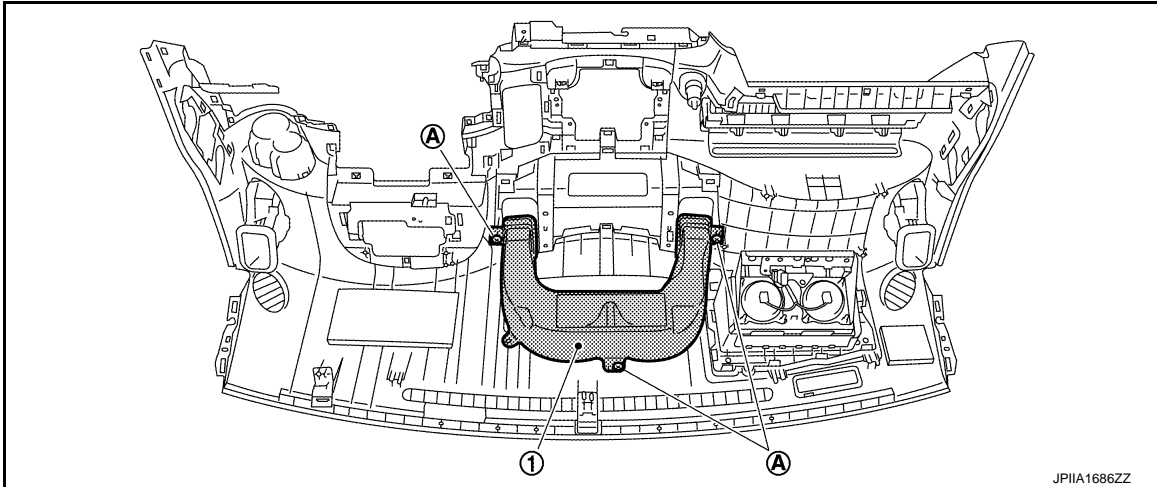

INSTALLATION

Installation is basically the reverse order of removal.

SIDE VENTILATOR DUCT

SIDE VENTILATOR DUCT : Removal and Installation

INFOID:000000004907729

REMOVAL

1. Remove instrument panel assembly. Refer to [IP-12, "Exploded View"](#).
2. Remove mounting screws (A), and then remove side ventilator duct (1) from the vehicle.

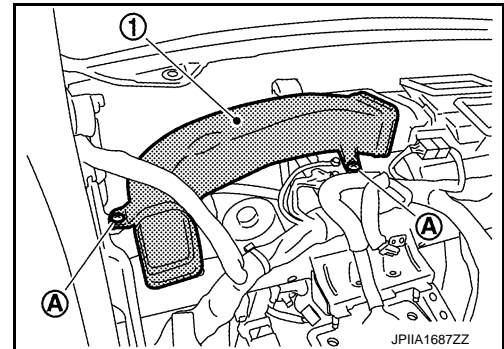

INSTALLATION

Installation is basically the reverse order of removal.

FRONT DEFROSTER NOZZLE

FRONT DEFROSTER NOZZLE : Removal and Installation

INFOID:000000004907730

REMOVAL

1. Remove side defroster nozzles. Refer to [VTL-7, "Exploded View"](#).

A
B
C
D
E
F
G
H
VTL
J
K
L
M
N
O
P

DUCT AND GRILLE

< REMOVAL AND INSTALLATION >

2. Remove mounting screw (A), and then remove front defroster nozzle (1) from instrument panel assembly.

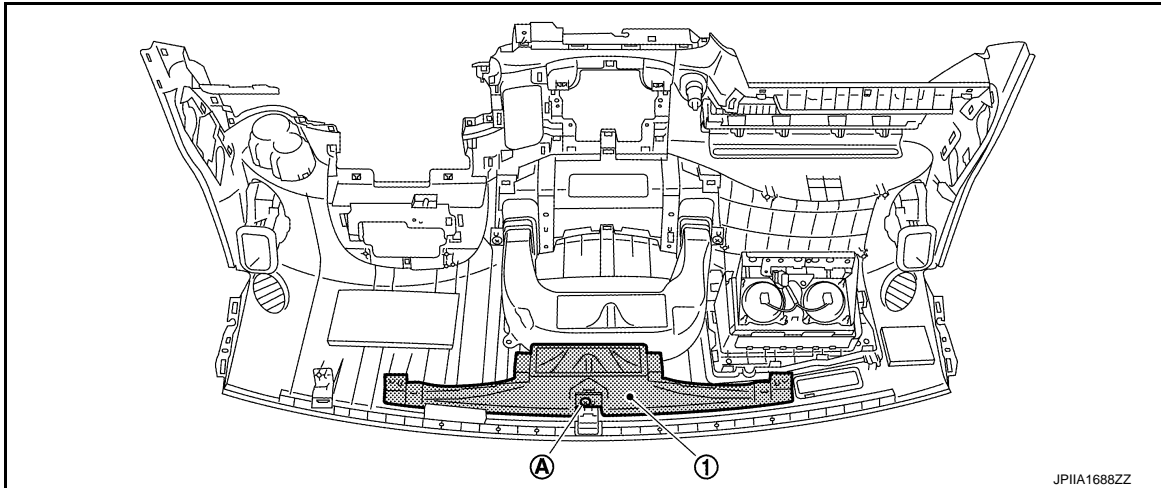

INSTALLATION

Installation is basically the reverse order of removal.

SIDE DEFROSTER NOZZLE

SIDE DEFROSTER NOZZLE : Removal and Installation

INFOID:000000004907731

REMOVAL

1. Remove instrument panel assembly. Refer to [IP-12. "Exploded View"](#).
2. Remove mounting screws (A), and then remove bracket (1).

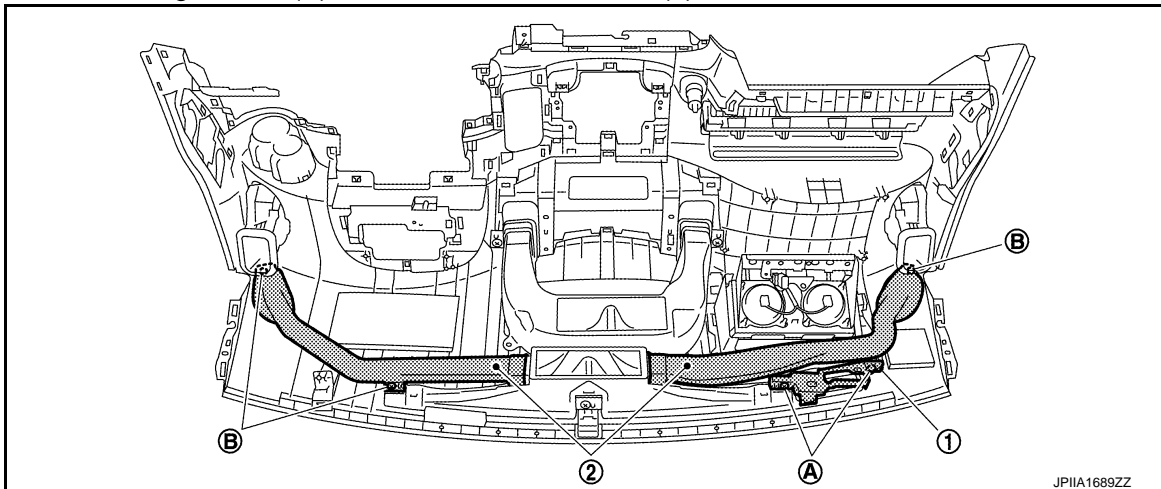

3. Remove mounting screws (B), and then remove side defroster nozzle (2) from instrument panel assembly.

INSTALLATION

Installation is basically the reverse order of removal.

REAR FOOT DUCT 1

REAR FOOT DUCT 1 : Removal and Installation

INFOID:000000004907742

REMOVAL

1. Remove instrument lower cover. Refer to [IP-12. "Exploded View"](#).
2. Remove rear foot duct 1 from the vehicle.

INSTALLATION

Installation is basically the reverse order of removal.

REAR FOOT DUCT 2

DUCT AND GRILLE

< REMOVAL AND INSTALLATION >

REAR FOOT DUCT 2 : Removal and Installation

INFOID:000000004907743

REMOVAL

Driver side

1. Remove center console assembly. Refer to [IP-22, "Exploded View"](#).
2. Remove harness clip (A) from rear foot duct 2 LH (1).

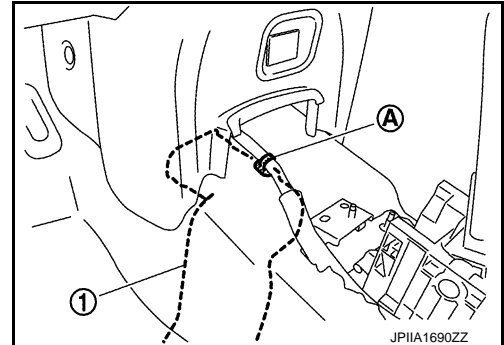

3. Remove front floor spacer LH. Refer to [INT-18, "Exploded View"](#).
4. Remove clip, and then remove rear foot duct 2 LH from the vehicle.

Passenger side

1. Remove center console assembly. Refer to [IP-22, "Exploded View"](#).
2. Remove front floor spacer RH. Refer to [INT-18, "Exploded View"](#).
3. Remove clip, and then remove rear foot duct 2 RH from the vehicle.

INSTALLATION

Installation is basically the reverse order of removal.

FOOT DUCT

FOOT DUCT : Removal and Installation

INFOID:000000004907733

REMOVAL

Driver side

1. Remove steering column lower cover. Refer to [IP-12, "Exploded View"](#).
2. Remove mounting nuts (A), and then remove knee protector upper (1).

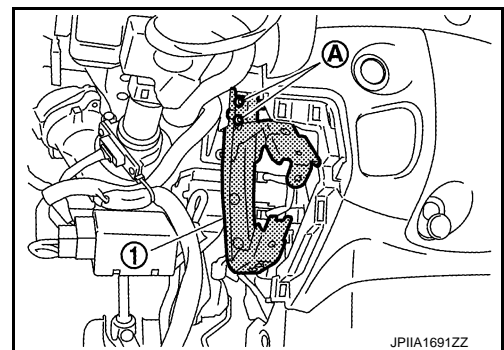

A
B
C
D
E
F
G
H
VTL
J
K
L
M
N
O
P

DUCT AND GRILLE

< REMOVAL AND INSTALLATION >

3. Remove mounting screws (A), and then remove foot duct LH (1).

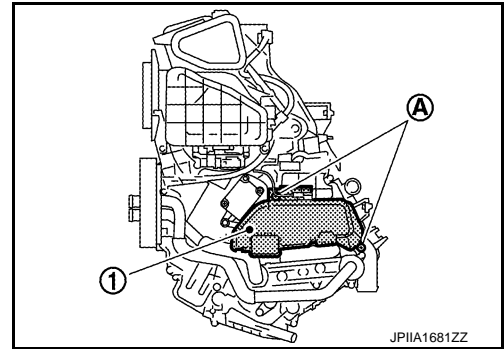

Passenger side

1. Remove instrument panel assembly. Refer to [IP-12, "Exploded View"](#).
2. Remove mounting screws (A), and then remove foot duct RH (1).

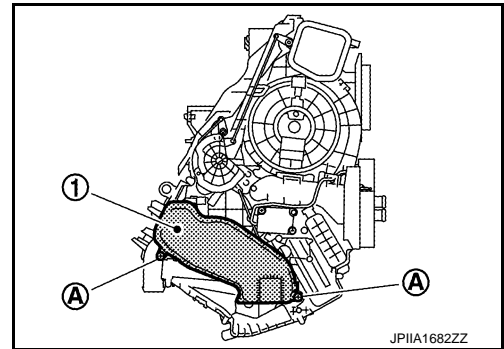

INSTALLATION

Installation is basically the reverse order of removal.

BLOWER MOTOR

< REMOVAL AND INSTALLATION >

BLOWER MOTOR

Exploded View

INFOID:000000004907734

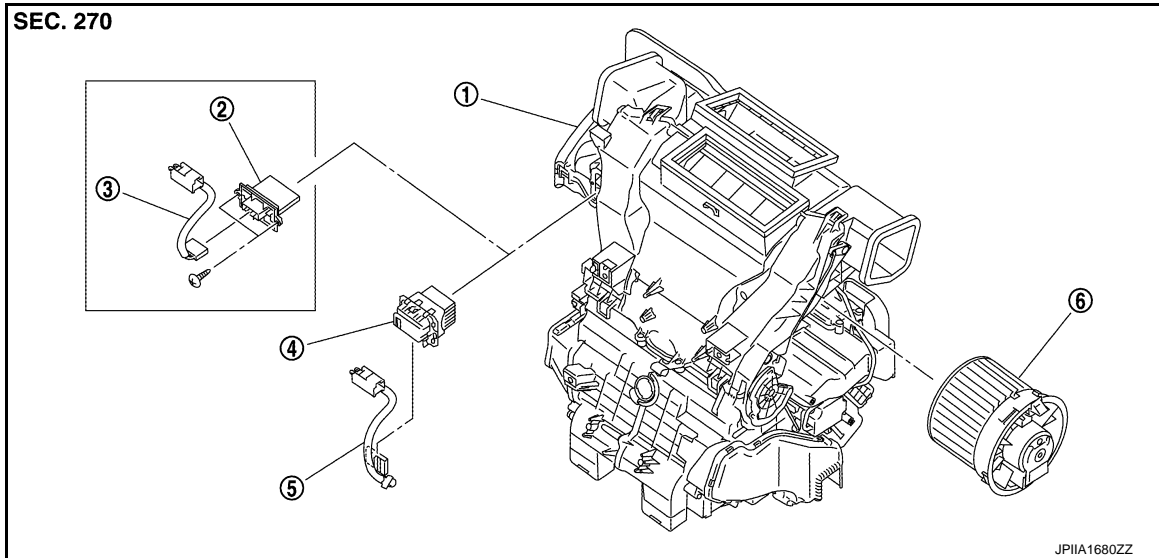

- | | | |
|-----------------------|--------------------------|------------------|
| 1. A/C unit assembly | 2. Blower fan resistor*1 | 3. Sub harness*1 |
| 4. Power transistor*2 | 5. Sub harness*2 | 6. Blower motor |

• *1: Manual air conditioner or Manual heater

• *2: Automatic air conditioner

Removal and Installation

INFOID:000000004907736

REMOVAL

1. Remove remote keyless entry receiver. Refer to [DLK-223, "Exploded View" \(WITH I-KEY\)](#) or [DLK-367, "Exploded View" \(WITHOUT I-KEY\)](#).
2. Disconnect blower motor connector.
3. Press flange holding hook (A), and then turn blower motor (1) clockwise.
4. Pull outside, and then remove blower motor.

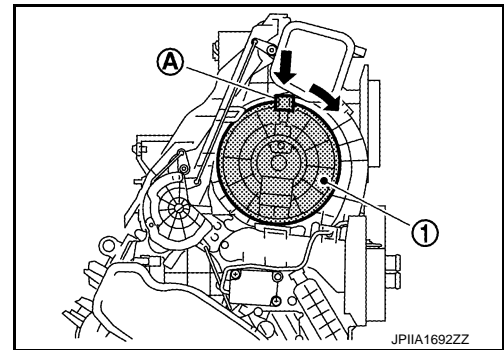

INSTALLATION

Installation is basically the reverse order of removal.

A
B
C
D
E
F
G
H
VTL
J
K
L
M
N
O
P