

WT
SECTION
ROAD WHEELS & TIRES

A
B
C
D

WT

CONTENTS

<p style="text-align: center;">REGULAR GRADE</p> <p>BASIC INSPECTION 4</p> <p>DIAGNOSIS AND REPAIR WORK FLOW 4</p> <p style="padding-left: 20px;">Work Flow4</p> <p>INSPECTION AND ADJUSTMENT 6</p> <p>TRANSMITTER WAKE UP OPERATION6</p> <p style="padding-left: 20px;">TRANSMITTER WAKE UP OPERATION : De- scription6</p> <p style="padding-left: 20px;">TRANSMITTER WAKE UP OPERATION : Spe- cial Repair Requirement6</p> <p>ID REGISTRATION PROCEDURE6</p> <p style="padding-left: 20px;">ID REGISTRATION PROCEDURE : Description.....6</p> <p style="padding-left: 20px;">ID REGISTRATION PROCEDURE : Special Re- pair Requirement6</p> <p>SYSTEM DESCRIPTION 9</p> <p>TPMS 9</p> <p style="padding-left: 20px;">System Diagram9</p> <p style="padding-left: 20px;">System Description9</p> <p style="padding-left: 20px;">Component Parts Location9</p> <p style="padding-left: 20px;">Component Description 10</p> <p>DIAGNOSIS SYSTEM (BCM)11</p> <p>COMMON ITEM 11</p> <p style="padding-left: 20px;">COMMON ITEM : CONSULT-III Function (BCM - COMMON ITEM) 11</p> <p>AIR PRESSURE MONITOR12</p> <p style="padding-left: 20px;">AIR PRESSURE MONITOR : Diagnosis Descrip- tion12</p> <p style="padding-left: 20px;">AIR PRESSURE MONITOR : CONSULT-III Func- tion 14</p> <p>DTC/CIRCUIT DIAGNOSIS16</p>	<p>C1704, C1705, C1706, C1707 LOW TIRE PRESSURE16</p> <p style="padding-left: 20px;">Description16</p> <p style="padding-left: 20px;">DTC Logic16</p> <p style="padding-left: 20px;">Diagnosis Procedure16</p> <p style="padding-left: 20px;">Special Repair Requirement17</p> <p>C1708, C1709, C1710, C1711 TRANSMITTER 18</p> <p style="padding-left: 20px;">Description18</p> <p style="padding-left: 20px;">DTC Logic18</p> <p style="padding-left: 20px;">Diagnosis Procedure18</p> <p style="padding-left: 20px;">Special Repair Requirement20</p> <p>C1712, C1713, C1714, C1715 TRANSMITTER21</p> <p style="padding-left: 20px;">Description21</p> <p style="padding-left: 20px;">DTC Logic21</p> <p style="padding-left: 20px;">Diagnosis Procedure21</p> <p style="padding-left: 20px;">Special Repair Requirement23</p> <p>C1716, C1717, C1718, C1719 TRANSMITTER24</p> <p style="padding-left: 20px;">Description24</p> <p style="padding-left: 20px;">DTC Logic24</p> <p style="padding-left: 20px;">Diagnosis Procedure24</p> <p style="padding-left: 20px;">Special Repair Requirement25</p> <p>C1720, C1721, C1722, C1723 TRANSMITTER26</p> <p style="padding-left: 20px;">Description26</p> <p style="padding-left: 20px;">DTC Logic26</p> <p style="padding-left: 20px;">Diagnosis Procedure26</p> <p style="padding-left: 20px;">Special Repair Requirement28</p> <p>C1724, C1725, C1726, C1727 TRANSMITTER29</p> <p style="padding-left: 20px;">Description29</p> <p style="padding-left: 20px;">DTC Logic29</p> <p style="padding-left: 20px;">Diagnosis Procedure29</p> <p style="padding-left: 20px;">Special Repair Requirement31</p>
---	--

F
G
H
I
J
K
L
M
N
O
P

C1729 VEHICLE SPEED SIGNAL	32	Description	82
Description	32	Diagnosis Procedure	82
DTC Logic	32		
Diagnosis Procedure	32		
Special Repair Requirement	32		
C1734 BCM	34		
Description	34		
DTC Logic	34		
Diagnosis Procedure	34		
Special Repair Requirement	35		
TIRE PRESSURE RECEIVER	36		
Description	36		
Component Function Check	36		
Diagnosis Procedure	36		
TIRE PRESSURE WARNING CHECK SWITCH	38		
Description	38		
Component Function Check	38		
Diagnosis Procedure	38		
LOW TIRE PRESSURE WARNING LAMP	40		
Description	40		
Component Function Check	40		
Diagnosis Procedure	40		
POWER SUPPLY AND GROUND CIRCUIT	41		
Diagnosis Procedure	41		
TPMS	42		
Wiring Diagram - TIRE PRESSURE MONITORING SYSTEM -	42		
ECU DIAGNOSIS INFORMATION	45		
BCM (BODY CONTROL MODULE)	45		
Reference Value	45		
Wiring Diagram - BCM -	66		
Fail-safe	70		
DTC Inspection Priority Chart	72		
DTC Index	74		
SYMPTOM DIAGNOSIS	77		
TPMS	77		
Symptom Table	77		
LOW TIRE PRESSURE WARNING LAMP DOES NOT BLINKS	80		
Description	80		
Diagnosis Procedure	80		
LOW TIRE PRESSURE WARNING LAMP DOES NOT TURN OFF	81		
Description	81		
Diagnosis Procedure	81		
LOW TIRE PRESSURE WARNING LAMP BLINKS	82		
		Description	82
		Diagnosis Procedure	82
		TURN SIGNAL LAMP BLINKS	84
		Description	84
		Diagnosis Procedure	84
		ID REGISTRATION CANNOT BE COMPLETED	85
		Description	85
		Diagnosis Procedure	85
		NORMAL OPERATING CONDITION	86
		Description	86
		NOISE, VIBRATION AND HARSHNESS (NVH) TROUBLESHOOTING	87
		NVH Troubleshooting Chart	87
		PRECAUTION	88
		PRECAUTIONS	88
		Precaution for Supplemental Restraint System (SRS) "AIR BAG" and "SEAT BELT PRE-TENSIONER"	88
		Service Notice or Precautions	88
		PREPARATION	89
		PREPARATION	89
		Special Service Tool	89
		Commercial Service Tool	89
		PERIODIC MAINTENANCE	90
		ROAD WHEEL	90
		Inspection	90
		REMOVAL AND INSTALLATION	91
		ROAD WHEEL TIRE ASSEMBLY	91
		Exploded View	91
		Removal and Installation	91
		Adjustment	91
		TRANSMITTER	94
		Exploded View	94
		Removal and Installation	94
		TIRE PRESSURE RECEIVER	96
		Exploded View	96
		Removal and Installation	96
		SERVICE DATA AND SPECIFICATIONS (SDS)	97
		SERVICE DATA AND SPECIFICATIONS (SDS)	97
		Road Wheel	97
		Tire Air Pressure	97

Krom

SPEC CHANGE INFORMATION	98	ROAD WHEEL TIRE ASSEMBLY	98
		Road Wheel Tire Assembly	98

A

B

C

D

WT

F

G

H

I

J

K

L

M

N

O

P

BASIC INSPECTION

DIAGNOSIS AND REPAIR WORK FLOW

Work Flow

INFOID:000000005038064

DETAILED FLOW

1. COLLECT THE INFORMATION FROM THE CUSTOMER

It is also important to clarify customer concerns before starting the inspection. Reproduce the symptom, and understand it fully. Interview the customer about the concerns carefully. In some cases, it is necessary to check the symptoms by driving the vehicle with the customer.

CAUTION:

Customers are not professionals. Never assume “maybe the customer means...” or “maybe the customer mentioned this symptom.”

>> GO TO 2.

2. CRUISE TEST

Start the engine and drive the vehicle.

Dose the symptom that customer concerns occur?

YES >> GO TO 3.

NO >> GO TO 4.

3. BASIC INSPECTION

Check the tire pressure for all wheels and adjust to the specified value. Refer to [WT-97, "Tire Air Pressure"](#).

Is the malfunction corrected?

YES >> INSPECTION END

NO >> GO TO 4.

4. PERFORM SELF-DIAGNOSIS

 **With CONSULT-III**

Perform self-diagnosis.

Is any DTC detected?

YES >> GO TO 6.

NO >> GO TO 5.

5. CHECK SYMPTOM

Perform trouble diagnosis for the applicable symptom. Refer to [WT-77, "Symptom Table"](#).

Is the cause of the malfunction detected?

YES >> GO TO 7.

NO >> GO TO 9.

6. CIRCUIT DIAGNOSIS

Inspect the malfunctioning system indicated by the DTC code that is detected during self-diagnosis. Refer to [WT-74, "DTC Index"](#).

>> GO TO 7.

7. REPAIR WORK

Repair or replace the malfunctioning part.

>> GO TO 8.

8. PERFORM SELF-DIAGNOSIS

1. Erase the self-diagnosis results memory of the low tire pressure warning control unit.
2. Drive the vehicle.

DIAGNOSIS AND REPAIR WORK FLOW

< BASIC INSPECTION >

[REGULAR GRADE]

3. Perform self-diagnosis.

Is any DTC detected?

YES >> GO TO 6.

NO >> GO TO 9.

9.FINAL CHECK

1. Perform a cruise test.

2. Check that the low tire pressure warning lamp turns OFF.

Dose the tire pressure warning lamp turn OFF?

YES >> INSPECTION END

NO >> GO TO 3.

A

B

C

D

WT

F

G

H

I

J

K

L

M

N

O

P

INSPECTION AND ADJUSTMENT
TRANSMITTER WAKE UP OPERATION

TRANSMITTER WAKE UP OPERATION : Description

INFOID:000000005038065

This procedure must be done after replacement of a transmitter, BCM, or rotation of wheels.

TRANSMITTER WAKE UP OPERATION : Special Repair Requirement

INFOID:000000005038066

1. TRANSMITTER WAKE-UP PROCEDURE

1. Turn the ignition switch ON.
2. Contact the transmitter activation tool (J-45295) (1) to the side of the tire at the location to the transmitter.
3. Press and hold the activation tool button while pushing the tool to the tire surface. (approximately for 5 seconds)

CAUTION:

Perform the wake-up procedure starting from the vehicle front left wheel, then repeat the procedure in the order of the front right wheel, rear right wheel, and rear left wheel.

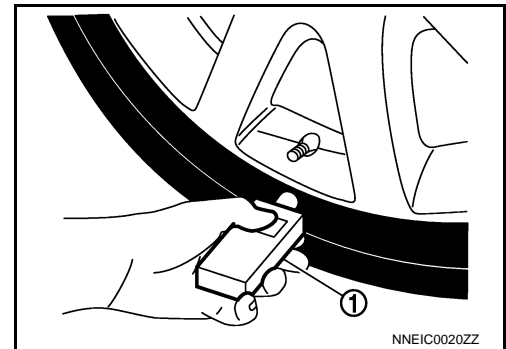

4. Check that the low tire pressure warning lamp blinks in the pattern shown as per the following. The pattern indicates that the transmitter wake-up procedure for the wheel is completed.

Low tire pressure warning lamp blinking timing		Activation tire position
ON OFF		a : 0.3 sec. b : 1.3 sec. Front LH
ON OFF		a : 0.3 sec. b : 1.3 sec. Front RH
ON OFF		a : 0.3 sec. b : 1.3 sec. Rear RH
ON OFF		a : 0.3 sec. b : 1.3 sec. Rear LH
ON OFF		a : 2 sec. b : 0.2 sec. All tires

SEIA0762E

5. Check that the turn signal lamps blink twice when the transmitter wake-up procedure for all wheels is completed.
6. Check that the low tire pressure warning lamp turns OFF, after the transmitter wake-up procedure is completed for all wheels and turns OFF.

Is the transmitter wake-up procedure completed?

YES >> Perform the transmitter ID registration procedure. Refer to [WT-6, "ID REGISTRATION PROCEDURE : Special Repair Requirement"](#).

NO >> Perform trouble diagnosis for the transmitter. Refer to [WT-18, "Diagnosis Procedure"](#).

ID REGISTRATION PROCEDURE

ID REGISTRATION PROCEDURE : Description

INFOID:000000005038067

This procedure must be done after replacing or rotating wheels, replacing transmitter or BCM.

ID REGISTRATION PROCEDURE : Special Repair Requirement

INFOID:000000005038068

1. TRANSMITTER ID REGISTRATION PROCEDURE

With CONSULT-III.

INSPECTION AND ADJUSTMENT

< BASIC INSPECTION >

[REGULAR GRADE]

1. Display the "WORK SUPPORT" screen and select "ID REGIST".

Is the transmitter activation tool (J-45295) used for the transmitter ID registration procedure?

- YES >> GO TO 2.
NO >> GO TO 3.

2. TRANSMITTER ID REGISTRATION PROCEDURE (WITH TRANSMITTER ACTIVATION TOOL)

1. Turn the ignition switch ON.
2. Select the start button on the "ID REGIST" screen.
3. Contact the transmitter activation tool (J-45295) (1) to the side of the tire at the location to the transmitter.
4. Press and hold the activation tool button while pushing the tool to the tire surface. (approximately for 5 seconds)

CAUTION:

Perform the ID registration procedure starting from the vehicle front left wheel, then repeat the procedure in the order of the front right wheel, rear right wheel, and rear left wheel.

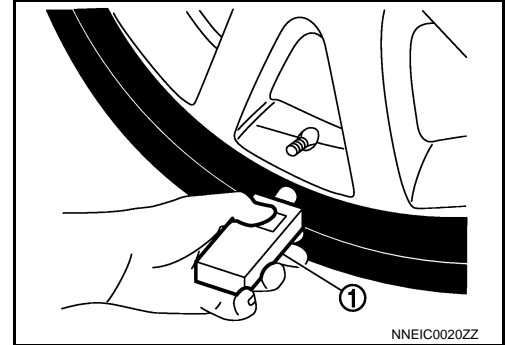

5. When ID registration is completed, check the following pattern at each wheel.

Se-quence	ID registration position	Turn signal lamp	CONSULT-III
1	Front left wheel	2 blinks	"Red" ↓ "Green"
2	Front right wheel		
3	Rear right wheel		
4	Rear left wheel		

6. After the ID registration procedure for all wheels is completed, press "END" to end ID registration, and check that ID registration for all wheels is completed.

Is the check result normal?

- YES >> ID registration END.
NO >> Performs trouble-diagnosis of the Tire Pressure Monitoring System (TPMS). Refer to [WT-12. "AIR PRESSURE MONITOR : Diagnosis Description"](#).

3. TRANSMITTER ID REGISTRATION PROCEDURE (WITHOUT TRANSMITTER ACTIVATION TOOL)

1. Adjust the tire pressure for all wheels to match the list below.

Tire position	Tire pressure kPa (kg/cm ² , psi)
Front LH	240 (2.4, 35)
Front RH	220 (2.2, 32)
Rear RH	200 (2.0, 29)
Rear LH	180 (1.8, 26)

2. Drive the vehicle at a speed at more than 40 km/h (25 MPH) for 3 minutes or more, then perform the transmitter ID registration procedure.
3. After ID registration for all wheels is completed, press "END" to end ID registration.

ID registration position	CONSULT-III
Front LH	"Red" ↓ "Green"
Front RH	
Rear RH	
Rear LH	

4. Adjust the tire pressures for all wheels to the specified value. Refer to [WT-97. "Tire Air Pressure"](#).

INSPECTION AND ADJUSTMENT

< BASIC INSPECTION >

[REGULAR GRADE]

Is ID registrations for all wheels completed?

YES >> ID registration END.

NO >> Performs trouble-diagnosis of the Tire Pressure Monitoring System (TPMS). Refer to [WT-12. "AIR PRESSURE MONITOR : Diagnosis Description"](#).

SYSTEM DESCRIPTION

TPMS

System Diagram

INFOID:000000005038069

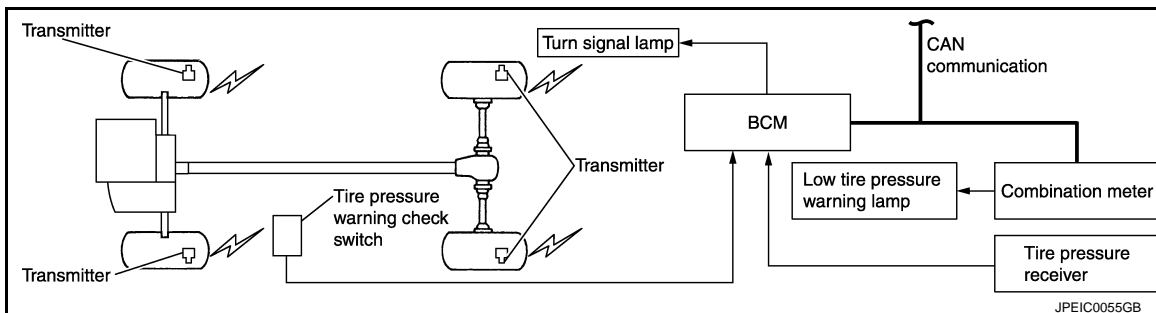

System Description

INFOID:000000005038070

DESCRIPTION

During driving, the TPMS (Tire Pressure Monitoring System) receives the signal transmitted from transmitter installed in each wheel. The BCM (Body Control Module) of this system has pressure judgment and trouble diagnosis functions. When the tire pressure monitoring system detects low inflation pressure or another unusual symptom, the low tire pressure warning lamps in the combination meter comes on.

Component Parts Location

INFOID:000000005038071

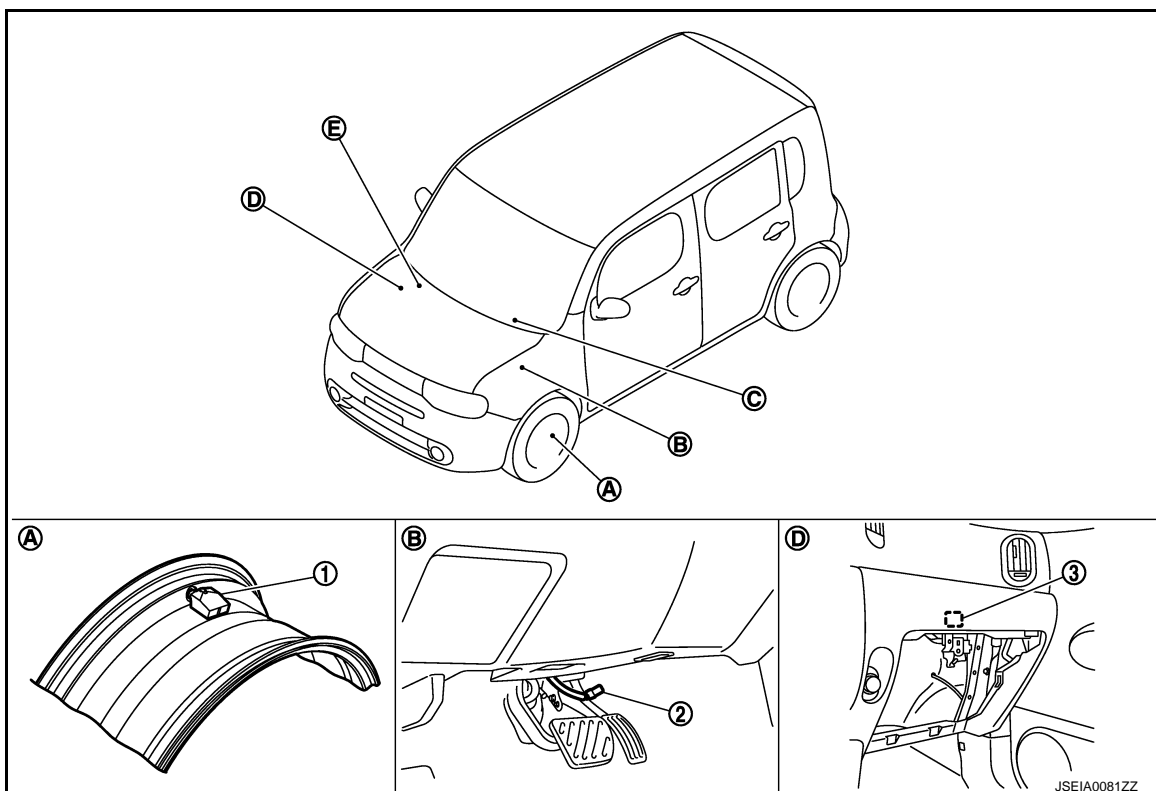

1. Transmitter
2. Tire pressure warning check switch
3. Tire pressure receiver

TPMS

< SYSTEM DESCRIPTION >

[REGULAR GRADE]

- | | | |
|---|-------------------------------------|---|
| A. Wheel
BCM | B. Behind instrument lower panel LH | C. Low tire pressure warning lamp
(On the combination meter) |
| D. Refer to BCS-9, "Component Parts Location" . | E. Glove box assembly | |

Component Description

INFOID:000000005038072

Component parts	Function
BCM (Body Control Module)	WT-34, "Description" .
Transmitter	WT-18, "Description" .
Tire pressure receiver	WT-36, "Description" .
Tire pressure warning check switch	WT-38, "Description" .
Turn signal lamp	ID registration of each wheel has been completed, turn signal lamp flashes.
Combination meter	Transmits the vehicle speed signal via CAN communication to BCM.
	Receives the following signals via CAN communication for BCM. <ul style="list-style-type: none"> • Low tire pressure warning lamp signal • Hazard lamp signal • Buzzer signal
Low tire pressure warning lamp	Illuminates if malfunction is detected in electrical system of TPMS.

DIAGNOSIS SYSTEM (BCM)

< SYSTEM DESCRIPTION >

[REGULAR GRADE]

DIAGNOSIS SYSTEM (BCM)

COMMON ITEM

COMMON ITEM : CONSULT-III Function (BCM - COMMON ITEM)

INFOID:000000005095021

APPLICATION ITEM

CONSULT-III performs the following functions via CAN communication with BCM.

Diagnosis mode	Function Description
Work Support	Changes the setting for each system function.
Self Diagnostic Result	Displays the diagnosis results judged by BCM.
CAN Diag Support Monitor	Monitors the reception status of CAN communication viewed from BCM. Refer to CONSULT-III operation manual.
Data Monitor	The BCM input/output signals are displayed.
Active Test	The signals used to activate each device are forcibly supplied from BCM.
Ecu Identification	The BCM part number is displayed.
Configuration	<ul style="list-style-type: none"> • Read and save the vehicle specification. • Write the vehicle specification when replacing BCM.

SYSTEM APPLICATION

BCM can perform the following functions for each system.

NOTE:

It can perform the diagnosis modes except the following for all sub system selection items.

x: Applicable item

System	Sub system selection item	Diagnosis mode		
		Work Support	Data Monitor	Active Test
Door lock	DOOR LOCK	x	x	x
Rear window defogger	REAR DEFOGGER		x	x
Warning chime	BUZZER		x	x
Interior room lamp timer	INT LAMP	x	x	x
Remote keyless entry system	MULTI REMOTE ENT*1	x	x	x
Exterior lamp	HEAD LAMP	x	x	x
Wiper and washer	WIPER	x*2	x	x
Turn signal and hazard warning lamps	FLASHER	x	x	x
—	AIR CONDITONER*3			
<ul style="list-style-type: none"> • Intelligent Key system • Engine start system 	INTELLIGENT KEY	x	x	x
Combination switch	COMB SW		x	
Body control system	BCM	x		
NVIS - NATS	IMMU		x	x
Interior room lamp battery saver	BATTERY SAVER	x	x	x
Back door opener system	TRUNK		x	x
Vehicle security system	THEFT ALM	x	x	x
RAP system	RETAINED PWR		x	
Signal buffer system	SIGNAL BUFFER		x	x
TPMS	TPMS (AIR PRESSURE MONITOR)	x	x	x

NOTE:

- *1: At models with Intelligent Key system this item is displayed, but is not used.
- *2: At models with rain sensor this mode is displayed, but is not used.

DIAGNOSIS SYSTEM (BCM)

[REGULAR GRADE]

< SYSTEM DESCRIPTION >

- *3: This item is displayed, but is not used.

FREEZE FRAME DATA (FFD)

The BCM records the following vehicle condition at the time a particular DTC is detected, and displays on CONSULT-III.

CONSULT screen item	Indication/Unit	Description	
Vehicle Speed	km/h	Vehicle speed of the moment a particular DTC is detected	
Odo/Trip Meter	km	Total mileage (Odometer value) of the moment a particular DTC is detected	
Vehicle Condition	SLEEP>LOCK	Power position status of the moment a particular DTC is detected	While turning BCM status from low power consumption mode to normal mode (Power supply position is "LOCK")
	SLEEP>OFF		While turning BCM status from low power consumption mode to normal mode (Power supply position is "OFF".)
	LOCK>ACC		While turning power supply position from "LOCK" to "ACC"
	ACC>ON		While turning power supply position from "ACC" to "IGN"
	RUN>ACC		While turning power supply position from "RUN" to "ACC" (Vehicle is stopping and selector lever is except P position.)
	CRANK>RUN		While turning power supply position from "CRANKING" to "RUN" (From cranking up the engine to run it)
	RUN>URGENT		While turning power supply position from "RUN" to "ACC" (Emergency stop operation)
	ACC>OFF		While turning power supply position from "ACC" to "OFF"
	OFF>LOCK		While turning power supply position from "OFF" to "LOCK"
	OFF>ACC		While turning power supply position from "OFF" to "ACC"
	ON>CRANK		While turning power supply position from "IGN" to "CRANKING"
	OFF>SLEEP		While turning BCM status from normal mode (Power supply position is "OFF".) to low power consumption mode
	LOCK>SLEEP		While turning BCM status from normal mode (Power supply position is "LOCK".) to low power consumption mode
	LOCK		Power supply position is "LOCK" (Ignition switch OFF with steering is locked.)
	OFF		Power supply position is "OFF" (Ignition switch OFF with steering is unlocked.)
	ACC		Power supply position is "ACC" (Ignition switch ACC)
	ON		Power supply position is "IGN" (Ignition switch ON with engine stopped)
ENGINE RUN	Power supply position is "RUN" (Ignition switch ON with engine running)		
CRANKING	Power supply position is "CRANKING" (At engine cranking)		
IGN Counter	0 - 39	<p>The number of times that ignition switch is turned ON after DTC is detected</p> <ul style="list-style-type: none"> The number is 0 when a malfunction is detected now. The number increases like 1 → 2 → 3...38 → 39 after returning to the normal condition whenever ignition switch OFF → ON. The number is fixed to 39 until the self-diagnosis results are erased if it is over 39. 	

AIR PRESSURE MONITOR

AIR PRESSURE MONITOR : Diagnosis Description

INFOID:000000005038074

DESCRIPTION

During driving, the transmitter installed at each road wheel transmits the tire pressure information signal to the receiver. The receiver receives the tire pressure signal and transmits it to the BCM. The BCM judges whether or not the tire pressure is OK based on the tire pressure information signal, and if it judges that the tire pressure is low, it transmits the information via CAN communication to the combination meter.

< SYSTEM DESCRIPTION >

After receiving the tire pressure information via CAN communication from the BCM, the combination meter illuminates the low tire pressure warning lamp and displays.

SELF DIAGNOSTIC PROCEDURE

1. Initiate diagnosis mode by short-circuiting the low tire pressure warning check switch to the ground.
2. The blinking pattern of the low tire pressure warning lamp indicates the conditions of the malfunction.

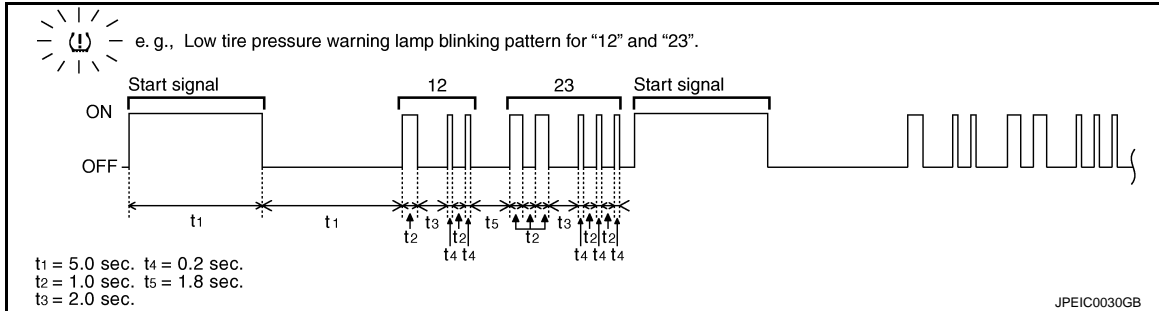

NOTE:

If the low tire pressure warning lamp is blinking repeatedly at 5 Hz, there is no malfunction occurring in the system.

Blinking pattern	Items	Diagnostic items detected when...	Check item
15	Tire pressure value (Front LH)	Front LH tire pressure drops to 182.7 kPa (1.9 kg/cm ² , 26 psi) or less.	
16	Tire pressure value (Front RH)	Front RH tire pressure drops to 182.7 kPa (1.9 kg/cm ² , 26 psi) or less.	
17	Tire pressure value (Rear RH)	Rear RH tire pressure drops to 182.7 kPa (1.9 kg/cm ² , 26 psi) or less.	
18	Tire pressure value (Rear LH)	Rear LH tire pressure drops to 182.7 kPa (1.9 kg/cm ² , 26 psi) or less.	
21	Transmitter no data (Front LH)	Data from front LH transmitter cannot be received.	WT-18
22	Transmitter no data (Front RH)	Data from front RH transmitter cannot be received.	
23	Transmitter no data (Rear RH)	Data from rear RH transmitter cannot be received.	
24	Transmitter no data (Rear LH)	Data from rear LH transmitter cannot be received.	
31	Transmitter checksum error (Front LH)	Checksum data from front LH transmitter is malfunctioning.	WT-21
32	Transmitter checksum error (Front RH)	Checksum data from front RH transmitter is malfunctioning.	
33	Transmitter checksum error (Rear RH)	Checksum data from rear RH transmitter is malfunctioning.	
34	Transmitter checksum error (Rear LH)	Checksum data from rear LH transmitter is malfunctioning.	
35	Transmitter pressure data error (Front LH)	Air pressure data from front LH transmitter is malfunction.	WT-24
36	Transmitter pressure data error (Front RH)	Air pressure data from front RH transmitter is malfunction.	
37	Transmitter pressure data error (Rear RH)	Air pressure data from rear RH transmitter is malfunction.	
38	Transmitter pressure data error (Rear LH)	Air pressure data from rear LH transmitter is malfunction.	

DIAGNOSIS SYSTEM (BCM)

< SYSTEM DESCRIPTION >

[REGULAR GRADE]

Blinking pattern	Items	Diagnostic items detected when...	Check item
41	Transmitter function code error (Front LH)	Function code data from front LH transmitter is malfunction.	WT-26
42	Transmitter function code error (Front RH)	Function code data from front RH transmitter is malfunction.	
43	Transmitter function code error (Rear RH)	Function code data from rear RH transmitter is malfunction.	
44	Transmitter function code error (Rear LH)	Function code data from rear LH transmitter is malfunction.	
45	Transmitter battery voltage low (Front LH)	Battery voltage of front LH transmitter drops.	WT-29
46	Transmitter battery voltage low (Front RH)	Battery voltage of front RH transmitter drops.	
47	Transmitter battery voltage low (Rear RH)	Battery voltage of rear RH transmitter drops.	
48	Transmitter battery voltage low (Rear LH)	Battery voltage of rear LH transmitter drops.	
52	Vehicle speed signal error	Vehicle speed signal error.	WT-32
53	Control unit	Tire pressure monitoring system malfunction in BCM.	WT-34
No blinking	Tire pressure warning check switch	Tire pressure warning switch circuit is open.	—

ERASE SELF-DIAGNOSIS

After performing self-diagnosis by short-circuiting the tire pressure warning check switch to the body, turn the ignition switch OFF.

AIR PRESSURE MONITOR : CONSULT-III Function

INFOID:000000005038075

FUNCTION

The diagnosis functions (main functions) include the following: "WORK SUPPORT", "SELF DIAGNOSTIC RESULT", "DATA MONITOR" and "ACTIVE TEST".

Diagnostic test mode	Function
Work support	In this mode, it is possible to make quick and accurate adjustments by following the instructions on the CONSULT-III display.
Self diagnostic result	Receives self-diagnosis results from the low tire pressure warning control unit, and indicates DTCs and the number of malfunctions.
Data monitor	Receives input/output signals from the low tire pressure warning control unit and indicates and stores them to facilitate locating the causes of malfunctions.
Active test	Transmits command to the low tire pressure warning control unit to change output signals and check operation of output system.

WORK SUPPORT MODE

Refer to [WT-6. "ID REGISTRATION PROCEDURE : Special Repair Requirement"](#).

SELF-DIAG RESULTS MODE

Refer to [WT-74. "DTC Index"](#).

DATA MONITOR MODE

Screen of data monitor mode is displayed.

NOTE:

When malfunction is detected, CONSULT-III perform REAL-TIME DIAGNOSIS. Also, any malfunction detected while in this mode will be displayed at real time.

DIAGNOSIS SYSTEM (BCM)

< SYSTEM DESCRIPTION >

[REGULAR GRADE]

Monitor item (Unit)	Remark
AIR PRESS FL (kPa), (kg/cm ²), (Psi)	Air pressure of tires
AIR PRESS FR (kPa), (kg/cm ²), (Psi)	
AIR PRESS RR (kPa), (kg/cm ²), (Psi)	
AIR PRESS RL (kPa), (kg/cm ²), (Psi)	
ID REGST FL1	ID is registered: Done ID is not registered: Yet
ID REGST FR1	
ID REGST RR1	
ID REGST RL1	
WARNING LAMP	Low tire pressure warning lamp ON: On Low tire pressure warning lamp OFF: Off
BUZZER	Combination meter buzzer ON: On Combination meter buzzer OFF: Off

NOTE:

Before performing the self-diagnosis, be sure to register the ID, or erase the actual malfunction location may be different from that displayed on CONSULT-III.

ACTIVE TEST MODE

NOTE:

Before performing the self-diagnosis, be sure to register the ID, or erase the actual malfunction may be different from that displayed on CONSULT-III.

TEST ITEM LIST

Test item	Content
WARNING LAMP	This test is able to check to check that the low tire pressure warning lamp turns on.
ID REGIST WARNING	This test is able to check to check that the buzzer sounds or the low tire pressure warning lamp turns on.
RUN FLAT TIRE W/L	NOTE: This item is displayed, but cannot be use this item.
FLASHER	This test is able to check to check that each turn signal lamp turns on.
HORN	This test is able to check to check that the horn sounds.

C1704, C1705, C1706, C1707 LOW TIRE PRESSURE

< DTC/CIRCUIT DIAGNOSIS >

[REGULAR GRADE]

DTC/CIRCUIT DIAGNOSIS

C1704, C1705, C1706, C1707 LOW TIRE PRESSURE

Description

INFOID:000000005038076

When the tire pressure monitoring system detects low inflation pressure, the low tire pressure warning lamps in the combination meter comes on.

DTC Logic

INFOID:000000005038077

DTC DETECTION LOGIC

DTC	Display item	Malfunction detected condition	Possible cause
C1704	LOW PRESSURE FL	Front LH tire pressure drops to 182.7 kPa (1.9 kg/cm ² , 26 psi) or less.	Low tire pressure
C1705	LOW PRESSURE FR	Front RH tire pressure drops to 182.7 kPa (1.9 kg/cm ² , 26 psi) or less.	
C1706	LOW PRESSURE RR	Rear RH tire pressure drops to 182.7 kPa (1.9 kg/cm ² , 26 psi) or less.	
C1707	LOW PRESSURE RL	Rear LH tire pressure drops to 182.7 kPa (1.9 kg/cm ² , 26 psi) or less.	

DTC CONFIRMATION PROCEDURE

1. DTC REPRODUCTION PROCEDURE

Ⓔ With CONSULT-III

1. Drive for 3 minutes at a speed of 40 km/h (25 MPH) or more, then drive normally for 10 minutes.
2. Perform BCM (AIR PRESSURE MONITOR) self-diagnosis.

Is DTC "C1704", "C1705", "C1706", "C1707" detected?

- YES >> Perform trouble diagnosis. Refer to [WT-16, "Diagnosis Procedure"](#).
NO >> INSPECTION END

Diagnosis Procedure

INFOID:000000005038078

1. CHECK TIRE PRESSURE

Check the internal pressure of all wheels. Refer to [WT-97, "Tire Air Pressure"](#).

Is the inspection result normal?

- YES >> Replace the DTC-detected malfunctioning transmitter. Refer to [WT-94, "Exploded View"](#).
NO >> After adjusting the air pressure, GO TO 2.

2. CHECK TIRE PRESSURE SIGNAL

Ⓔ With CONSULT-III

1. Drive for 3 minutes at a speed of 40 km/h (25 MPH) or more, then drive normally for 10 minutes.
2. On "DATA MONITOR", select "AIR PRESS FL", "AIR PRESS FR", "AIR PRESS RR" and "AIR PRESS RL", and check that the tire pressures match the standard value.

Monitor item	Condition	Displayed value
AIR PRESS FL	Drive for 3 minutes at a speed of 40 km/h (25 MPH) or more, then drive normally for 10 minutes.	Internal pressure of tires
AIR PRESS FR		
AIR PRESS RR		
AIR PRESS RL		

CAUTION:

Stop the vehicle and within 5 minutes, use CONSULT-III "DATA MONITOR" to display the tire pressure for all wheels.

C1704, C1705, C1706, C1707 LOW TIRE PRESSURE

< DTC/CIRCUIT DIAGNOSIS >

[REGULAR GRADE]

Is the inspection result normal?

YES >> Inspect or repair the tires or wheels and adjust the tire pressure to the specification.

NO >> GO TO 1.

A

Special Repair Requirement

INFOID:000000005038079

B

1.CHECK TIRE PRESSURE

Check all tires for tire pressures. Refer to [WT-97, "Tire Air Pressure"](#).

C

Does all tire pressure data meet the specification?

YES >> GO TO 2.

NO >> Inspect or repair the tires or wheels and adjust the tire pressure to the specification.

D

2.PERFORM ID REGISTRATION

Perform ID registration. Refer to [WT-6, "ID REGISTRATION PROCEDURE : Special Repair Requirement"](#).

WT

>> END

F

G

H

I

J

K

L

M

N

O

P

C1708, C1709, C1710, C1711 TRANSMITTER

< DTC/CIRCUIT DIAGNOSIS >

[REGULAR GRADE]

C1708, C1709, C1710, C1711 TRANSMITTER

Description

INFOID:000000005038080

The transmitter integrated with a valve is installed on a wheel, and transmits a detected tire pressure signal by radio wave.

DTC Logic

INFOID:000000005038081

DTC DETECTION LOGIC

DTC	Display item	Malfunction detected condition	Possible cause
C1708	[NO DATA] FL	Tire pressure data signal from the front left wheel transmitter cannot be detected.	<ul style="list-style-type: none">• Harness or connector (Tire pressure receiver, BCM)• ID registration is not finished• Transmitter malfunction• BCM malfunction
C1709	[NO DATA] FR	Tire pressure data signal from the front right wheel transmitter cannot be detected.	
C1710	[NO DATA] RR	Tire pressure data signal from the rear right wheel transmitter cannot be detected.	
C1711	[NO DATA] RL	Tire pressure data signal from the rear left wheel transmitter cannot be detected.	

DTC CONFIRMATION PROCEDURE

1. DTC REPRODUCTION PROCEDURE

Ⓜ With CONSULT-III

1. Drive for 3 minutes at a speed of 40 km/h (25 MPH) or more, then drive normally for 10 minutes.
2. Perform BCM (AIR PRESSURE MONITOR) self-diagnosis.

Is DTC "C1708", "C1709", "C1710", "C1711" detected?

- YES >> Perform trouble diagnosis. Refer to [WT-18, "Diagnosis Procedure"](#).
NO >> INSPECTION END

Diagnosis Procedure

INFOID:000000005038082

1. CHECK TIRE PRESSURE SIGNAL

Ⓜ With CONSULT-III

1. Drive for 3 minutes at a speed of 40 km/h (25 MPH) or more, then drive normally for 10 minutes.
2. On "DATA MONITOR", select "AIR PRESS FL", "AIR PRESS FR", "AIR PRESS RR" and "AIR PRESS RL", and check that the tire pressures match the standard value.

Monitor item	Condition	Displayed value
AIR PRESS FL	Drive for 3 minutes at a speed of 40 km/h (25 MPH) or more, then drive normally for 10 minutes.	Internal pressure of tires
AIR PRESS FR		
AIR PRESS RR		
AIR PRESS RL		

CAUTION:

Stop the vehicle and within 5 minutes, use CONSULT-III "DATA MONITOR" to display the tire pressure for all wheels.

Is a tire pressure of 0 kPa (0 Psi) displayed for all wheels?

- YES >> GO TO 2.
NO >> GO TO 5.

2. CHECK HARNESS BETWEEN BCM AND TIRE PRESSURE RECEIVER

1. Turn the ignition switch OFF.
2. Disconnect BCM harness connector and tire pressure receiver harness connector.
3. Check the continuity between BCM harness connector and tire pressure receiver harness connector.

C1708, C1709, C1710, C1711 TRANSMITTER

< DTC/CIRCUIT DIAGNOSIS >

[REGULAR GRADE]

BCM		Tire pressure receiver		Continuity
Connector	Terminal	Connector	Terminal	
M68	18	M13	1	Existed
M71	110		4	
	71		2	

4. Check the continuity between BCM harness connector and ground.

BCM		—	Continuity
Connector	Terminal		
M68	18	Ground	Not existed
M71	110		
	71		

Is the inspection result normal?

YES >> GO TO 3.

NO >> Repair or replace damaged parts.

3. CHECK TIRE PRESSURE RECEIVER POWER SUPPLY CIRCUIT

1. Connect the BCM harness connector.

2. Turn the ignition switch ON.

CAUTION:

Never start the engine.

3. Check the voltage between the BCM harness connector and ground.

BCM		—	Voltage
Connector	Terminal		
M68	10	Ground	5 V

Is the inspection result normal?

YES >> GO TO 4.

NO >> Repair or replace damaged parts.

4. CHECK TIRE PRESSURE RECEIVER

Check tire pressure receiver. Refer to [WT-36. "Diagnosis Procedure"](#).

Is the inspection result normal?

YES >> GO TO 5.

NO >> Replace tire pressure receiver. Refer to [WT-96. "Exploded View"](#).

5. CHECK ID REGISTRATION

Perform ID registration of all transmitters. Refer to [WT-6. "ID REGISTRATION PROCEDURE : Special Repair Requirement"](#).

Can ID registration of all transmitters be completed?

YES >> GO TO 6.

NO >> Replace transmitter. Refer to [WT-94. "Exploded View"](#).

6. CHECK TIRE PRESSURE MONITORING SYSTEM

Ⓜ With CONSULT-III

1. Drive at a speed of 40 km/h (25 MPH) or more for several minutes without stopping.

2. On "DATA MONITOR", select "AIR PRESS FL", "AIR PRESS FR", "AIR PRESS RR" and "AIR PRESS RL", and check that the tire pressures match the standard value.

C1708, C1709, C1710, C1711 TRANSMITTER

< DTC/CIRCUIT DIAGNOSIS >

[REGULAR GRADE]

Monitor item	Condition	Displayed value
AIR PRESS FL	Drive at a speed of 40 km/h (25 MPH) or more, for several minutes without stopping.	Internal pressure of tires
AIR PRESS FR		
AIR PRESS RR		
AIR PRESS RL		

CAUTION:

Stop the vehicle and within 15 minutes use the CONSULT-III "DATA MONITOR" to read the tire pressure for all wheels.

Is the inspection result normal?

YES >> Replace the DTC-detected malfunctioning transmitter. Refer to [WT-94, "Exploded View"](#).

NO >> Replace BCM. Refer to [BCS-82, "Exploded View"](#).

Special Repair Requirement

INFOID:000000005038083

1. CHECK TIRE PRESSURE

Check all tires for tire pressures. Refer to [WT-97, "Tire Air Pressure"](#).

Does all tire pressure data meet the specification?

YES >> GO TO 2.

NO >> Inspect or repair the tires or wheels and adjust the tire pressure to the specification.

2. PERFORM ID REGISTRATION

Perform ID registration. Refer to [WT-6, "ID REGISTRATION PROCEDURE : Special Repair Requirement"](#).

>> END

C1712, C1713, C1714, C1715 TRANSMITTER

< DTC/CIRCUIT DIAGNOSIS >

[REGULAR GRADE]

C1712, C1713, C1714, C1715 TRANSMITTER

Description

INFOID:000000005038084

The transmitter integrated with a valve is installed on a wheel, and transmits a detected tire pressure signal by radio wave.

DTC Logic

INFOID:000000005038085

DTC DETECTION LOGIC

DTC	Display item	Malfunction detected condition	Possible case
C1712	[CHECKSUM ERR] FL	Checksum data from front LH transmitter is malfunctioning.	<ul style="list-style-type: none">• Tire pressure receiver malfunction• Transmitter malfunction• BCM malfunction• Harness or connector
C1713	[CHECKSUM ERR] FR	Checksum data from front RH transmitter is malfunctioning.	
C1714	[CHECKSUM ERR] RR	Checksum data from rear RH transmitter is malfunctioning.	
C1715	[CHECKSUM ERR] RL	Checksum data from rear LH transmitter is malfunctioning.	

DTC CONFIRMATION PROCEDURE

1. DTC REPRODUCTION PROCEDURE

④ With CONSULT-III

1. Drive at a speed of 40 km/h (25 MPH) or more, then stop the vehicle for several minutes.
2. Perform BCM (AIR PRESSURE MONITOR) self-diagnosis.

Is DTC "C1712", "C1713", "C1714", "C1715" detected?

- YES >> Perform trouble diagnosis. Refer to [WT-21, "Diagnosis Procedure"](#).
NO >> INSPECTION END

Diagnosis Procedure

INFOID:000000005038086

1. CHECK ID REGISTRATION

④ With CONSULT-III

1. Perform the ID registration of all transmitters. Refer to [WT-6, "ID REGISTRATION PROCEDURE : Special Repair Requirement"](#).
2. On "DATA MONITOR", select "AIR PRESS FL", "AIR PRESS FR", "AIR PRESS RR" and "AIR PRESS RL", and check that the tire pressures match the standard value.

Monitor item	Condition	Displayed value
AIR PRESS FL	Drive for 3 minutes at a speed of 40 km/h (25 MPH) or more, then drive normally for 10 minutes.	Internal pressure of tires
AIR PRESS FR		
AIR PRESS RR		
AIR PRESS RL		

CAUTION:

Stop the vehicle and within 5 minutes, use CONSULT-III "DATA MONITOR" to display the tire pressure for all wheels.

Is the inspection result normal?

- YES >> GO TO 7.
NO >> GO TO 2.

2. CHECK TIRE PRESSURE SIGNAL

④ With CONSULT-III

1. Select "DATA MONITOR" mode for "AIR PRESSURE MONITOR" with CONSULT-III.
2. Read out the value of "AIR PRESS FL", "AIR PRESS FR", "AIR PRESS RR" and "AIR PRESS RL".

C1712, C1713, C1714, C1715 TRANSMITTER

< DTC/CIRCUIT DIAGNOSIS >

[REGULAR GRADE]

- Check that the tire pressure is the specified value.

Monitor item	Condition	Displayed value
AIR PRESS FL	Drive for 3 minutes at a speed of 40 km/h (25 MPH) or more, then drive normally for 10 minutes.	Internal pressure of tires
AIR PRESS FR		
AIR PRESS RR		
AIR PRESS RL		

CAUTION:

Stop the vehicle and within 5 minutes, use CONSULT-III "DATA MONITOR" to display the tire pressure for all wheels.

Is the inspection 0 kPa (0 Psi)?

YES >> GO TO 3.

NO >> GO TO 6.

3.CHECK HARNESS BETWEEN BCM AND TIRE PRESSURE RECEIVER

- Turn the ignition switch OFF.
- Disconnect BCM harness connector and tire pressure receiver harness connector.
- Check the continuity between BCM harness connector and tire pressure receiver harness connector.

BCM		Tire pressure receiver		Continuity
Connector	Terminal	Connector	Terminal	
M68	18	M13	1	Existed
M71	110		4	
	71		2	

- Check the continuity between BCM harness connector and ground.

BCM		—	Continuity
Connector	Terminal		
M68	18	Ground	Not existed
M71	110		
	71		

Is the inspection result normal?

YES >> GO TO 4.

NO >> Repair or replace error-detected parts.

4.CHECK TIRE PRESSURE RECEIVER POWER SUPPLY CIRCUIT

- Connect the BCM harness connector.
- Turn the ignition switch ON.
CAUTION:
Never start the engine.
- Check the voltage between the BCM harness connector and ground.

BCM		—	Voltage
Connector	Terminal		
M68	10	Ground	5 V

Is the inspection result normal?

YES >> GO TO 5.

NO >> Repair or replace error-detected parts.

5.CHECK TIRE PRESSURE RECEIVER

Check the tire pressure receiver. Refer to [WT-36, "Diagnosis Procedure"](#).

Is the inspection result normal?

C1712, C1713, C1714, C1715 TRANSMITTER

< DTC/CIRCUIT DIAGNOSIS >

[REGULAR GRADE]

- YES >> Replace tire pressure receiver. Refer to [WT-96, "Exploded View"](#).
NO >> GO TO 6.

6. CHECK ID REGISTRATION

Perform ID registration of all transmitters. Refer to [WT-6, "ID REGISTRATION PROCEDURE : Special Repair Requirement"](#).

Can ID registration of all transmitters be completed?

- YES >> GO TO 7.
NO >> Replace the DTC-detected malfunctioning transmitter. Refer to [WT-94, "Exploded View"](#).

7. CHECK TIRE PRESSURE MONITORING SYSTEM

Ⓜ With CONSULT-III

1. Drive at a speed of 40 km/h (25 MPH) or more for several minutes without stopping.
2. On "DATA MONITOR", select "AIR PRESS FL", "AIR PRESS FR", "AIR PRESS RR" and "AIR PRESS RL", and check that the tire pressures match the standard value.

Monitored item	Condition	Display value
AIR PRESS FL	Start the engine and drive at a 40 km/h (25 MPH) or more for several minutes.	Approximately equal to the indication on vehicle information display.
AIR PRESS FR		
AIR PRESS RR		
AIR PRESS RL		

CAUTION:

Stop the vehicle and within 15 minutes use the CONSULT-III "DATA MONITOR" to read the tire pressure for all wheels.

Is the inspection result normal?

- YES >> Replace the DTC-detected malfunctioning transmitter. Refer to [WT-94, "Exploded View"](#).
NO >> Replace BCM. Refer to [BCS-82, "Exploded View"](#).

Special Repair Requirement

INFOID:000000005038087

1. CHECK TIRE PRESSURE

Check all tires for tire pressures. Refer to [WT-97, "Tire Air Pressure"](#).

Does all tire pressure data meet the specification?

- YES >> GO TO 2.
NO >> Inspect or repair the tires or wheels and adjust the tire pressure to the specification.

2. PERFORM ID REGISTRATION

Perform ID registration. Refer to [WT-6, "ID REGISTRATION PROCEDURE : Special Repair Requirement"](#).

>> END

C1716, C1717, C1718, C1719 TRANSMITTER

< DTC/CIRCUIT DIAGNOSIS >

[REGULAR GRADE]

C1716, C1717, C1718, C1719 TRANSMITTER

Description

INFOID:000000005038088

The transmitter integrated with a valve is installed on a wheel, and transmits a detected tire pressure signal by radio wave.

DTC Logic

INFOID:000000005038089

DTC DETECTION LOGIC

DTC	Display item	Malfunction detected condition	Possible case
C1716	[PRESSDATA ERR] FL	Malfunction in the tire pressure data from the front left wheel transmitter.	<ul style="list-style-type: none">• ID registration is not finished• Transmitter malfunction
C1717	[PRESSDATA ERR] FR	Malfunction in the tire pressure data from the front right wheel transmitter.	
C1718	[PRESSDATA ERR] RR	Malfunction in the tire pressure data from the rear right wheel transmitter.	
C1719	[PRESSDATA ERR] RL	Malfunction in the tire pressure data from the rear left wheel transmitter.	

DTC CONFIRMATION PROCEDURE

1. DTC REPRODUCTION PROCEDURE

Ⓟ With CONSULT-III

1. Drive for 3 minutes at a speed of 40 km/h (25 MPH) or more, then drive normally for 10 minutes.
2. Perform BCM (AIR PRESSURE MONITOR) self-diagnosis.

Is DTC "C1716", "C1717", "C1718", "C1719" detected?

- YES >> Perform trouble diagnosis. Refer to [WT-24, "Diagnosis Procedure"](#).
NO >> INSPECTION END

Diagnosis Procedure

INFOID:000000005038090

1. CHECK TIRE PRESSURE

Check the internal pressure of all wheels. Refer to [WT-97, "Tire Air Pressure"](#).

Is the inspection result normal?

- YES >> Replace the DTC-detected malfunctioning transmitter. Refer to [WT-94, "Exploded View"](#).
NO >> After adjusting the tire pressure, GO TO 2.

2. CHECK TIRE PRESSURE SIGNAL

Ⓟ With CONSULT-III

1. Check and adjust the tire pressure for all wheels. Refer to [WT-97, "Tire Air Pressure"](#).
2. Perform transmitter ID registration for all wheels. Refer to [WT-6, "ID REGISTRATION PROCEDURE : Special Repair Requirement"](#).
3. Drive for 3 minutes at a speed of 40 km/h (25 MPH) or more, then drive normally for 10 minutes.
4. On "DATA MONITOR", select "AIR PRESS FL", "AIR PRESS FR", "AIR PRESS RR" and "AIR PRESS RL", and check that the tire pressures match the standard value.
CAUTION:
Stop the vehicle and within 15 minutes, use CONSULT-III "DATA MONITOR" to display the tire pressure for all wheels.
5. Check that "DATA MONITOR" displays tire pressure of 438.60 kPa (63.60 Psi).

Is the inspection 438.60 kPa (63.60 Psi)?

- YES >> Replace transmitter the tire pressure 438.60 kPa (63.60 Psi) displayed. Refer to [WT-94, "Exploded View"](#).
NO >> GO TO 1.

C1716, C1717, C1718, C1719 TRANSMITTER

< DTC/CIRCUIT DIAGNOSIS >

[REGULAR GRADE]

Special Repair Requirement

INFOID:000000005038091

1.CHECK TIRE PRESSURE

Check all tires for tire pressures. Refer to [WT-97, "Tire Air Pressure"](#).

Does all tire pressure data meet the specification?

YES >> GO TO 2.

NO >> Inspect or repair the tires or wheels and adjust the tire pressure to the specification.

2.PERFORM ID REGISTRATION

Perform ID registration. Refer to [WT-6, "ID REGISTRATION PROCEDURE : Special Repair Requirement"](#).

>> END

A
B
C
D
E
F
G
H
I
J
K
L
M
N
O
P

WT

C1720, C1721, C1722, C1723 TRANSMITTER

< DTC/CIRCUIT DIAGNOSIS >

[REGULAR GRADE]

C1720, C1721, C1722, C1723 TRANSMITTER

Description

INFOID:000000005038092

The transmitter integrated with a valve is installed on a wheel, and transmits a detected tire pressure signal by radio wave.

DTC Logic

INFOID:000000005038093

DTC DETECTION LOGIC

DTC	Display item	Malfunction detected condition	Possible case
C1720	[CODE ERR] FL	Malfunction in the tire pressure data from the front left wheel transmitter.	<ul style="list-style-type: none">• Tire pressure receiver malfunction• Transmitter malfunction• BCM malfunction• Harness or connector
C1721	[CODE ERR] FR	Malfunction in the tire pressure data from the front right wheel transmitter.	
C1722	[CODE ERR] RR	Malfunction in the tire pressure data from the rear right wheel transmitter.	
C1723	[CODE ERR] RL	Malfunction in the tire pressure data from the rear left wheel transmitter.	

DTC CONFIRMATION PROCEDURE

1. DTC REPRODUCTION PROCEDURE

④ With CONSULT-III

1. Drive for 3 minutes at a speed of 40 km/h (25 MPH) or more, then drive normally for 10 minutes.
2. Perform BCM (AIR PRESSURE MONITOR) self-diagnosis.

Is DTC "C1720", "C1721", "C1722", "C1723" detected?

- YES >> Perform trouble diagnosis. Refer to [WT-26, "Diagnosis Procedure"](#).
NO >> INSPECTION END

Diagnosis Procedure

INFOID:000000005038094

1. CHECK ID REGISTRATION

④ With CONSULT-III

1. Perform the ID registration of all transmitters. Refer to [WT-6, "ID REGISTRATION PROCEDURE : Special Repair Requirement"](#).
2. Drive for 3 minutes at a speed of 40 km/h (25 MPH) or more, then drive normally for 10 minutes.
3. On "DATA MONITOR", select "AIR PRESS FL", "AIR PRESS FR", "AIR PRESS RR" and "AIR PRESS RL", and check that the tire pressures match the standard value.

Monitor item	Condition	Displayed value
AIR PRESS FL	Drive for 3 minutes at a speed of 40 km/h (25 MPH) or more, then drive normally for 10 minutes.	Internal pressure of tires
AIR PRESS FR		
AIR PRESS RR		
AIR PRESS RL		

CAUTION:

Stop the vehicle and within 5 minutes, use CONSULT-III "DATA MONITOR" to display the tire pressure for all wheels.

Is the inspection result normal?

- YES >> GO TO 6.
NO >> GO TO 2.

2. CHECK TIRE PRESSURE SIGNAL

④ With CONSULT-III

1. Drive for 3 minutes at a speed of 40 km/h (25 MPH) or more, then drive normally for 10 minutes.

C1720, C1721, C1722, C1723 TRANSMITTER

< DTC/CIRCUIT DIAGNOSIS >

[REGULAR GRADE]

2. On "DATA MONITOR", select "AIR PRESS FL", "AIR PRESS FR", "AIR PRESS RR" and "AIR PRESS RL", and check that the tire pressures match the standard value.

Monitor item	Condition	Displayed value
AIR PRESS FL	Drive for 3 minutes at a speed of 40 km/h (25 MPH) or more, then drive normally for 10 minutes.	Internal pressure of tires
AIR PRESS FR		
AIR PRESS RR		
AIR PRESS RL		

Are all tire pressure displayed 0 kPa (0 Psi)?

- YES >> GO TO 3.
 NO >> GO TO 6.

3. CHECK HARNESS BETWEEN BCM AND TIRE PRESSURE RECEIVER

1. Turn the ignition switch OFF.
2. Disconnect BCM harness connector and tire pressure receiver harness connector.
3. Check continuity between BCM harness connector and tire pressure receiver harness connector.

BCM		Tire pressure receiver		Continuity
Connector	Terminal	Connector	Terminal	
M68	18	M13	1	Existed
M71	110		4	
	71		2	

4. Check continuity between BCM harness connector and ground.

BCM		—	Continuity
Connector	Terminal		
M68	18	Ground	Not existed
M71	110		
	71		

Is the inspection result normal?

- YES >> GO TO 4.
 NO >> Repair or replace error-detected parts.

4. CHECK TIRE PRESSURE RECEIVER POWER SUPPLY CIRCUIT

1. Connect the BCM harness connector.
2. Turn the ignition switch ON.
CAUTION:
Never start the engine.
3. Check the voltage between the BCM harness connector and ground.

BCM		—	Voltage
Connector	Terminal		
M68	10	Ground	5 V

Is the inspection result normal?

- YES >> GO TO 5.
 NO >> Repair or replace damaged parts.

5. CHECK TIRE PRESSURE RECEIVER

Check tire pressure receiver. Refer to [WT-36. "Diagnosis Procedure"](#).

Is the inspection result normal?

- YES >> GO TO 6.
 NO >> Replace tire pressure receiver. Refer to [WT-96. "Exploded View"](#).

C1720, C1721, C1722, C1723 TRANSMITTER

< DTC/CIRCUIT DIAGNOSIS >

[REGULAR GRADE]

6.CHECK TIRE PRESSURE MONITORING SYSTEM

④ With CONSULT-III

1. Drive for 3 minutes at a speed of 40 km/h (25 MPH) or more, then drive normally for 10 minutes.
2. On "DATA MONITOR", select "AIR PRESS FL", "AIR PRESS FR", "AIR PRESS RR" and "AIR PRESS RL", and check that the tire pressures match the standard value.

Monitor item	Condition	Displayed value
AIR PRESS FL	Drive for 3 minutes at a speed of 40 km/h (25 MPH) or more, then drive normally for 10 minutes.	Internal pressure of tires
AIR PRESS FR		
AIR PRESS RR		
AIR PRESS RL		

CAUTION:

Stop the vehicle and within 5 minutes, use CONSULT-III "DATA MONITOR" to display the tire pressure for all wheels.

Is the inspection result normal?

- YES >> Replace the DTC-detected malfunctioning transmitter. Refer to [WT-94. "Exploded View"](#).
NO >> Replace BCM. Refer to [BCS-82. "Exploded View"](#).

Special Repair Requirement

INFOID:000000005038095

1.CHECK TIRE PRESSURE

Check all tires for tire pressures. Refer to [WT-97. "Tire Air Pressure"](#).

Does all tire pressure data meet the specification?

- YES >> GO TO 2.
NO >> Inspect or repair the tires or wheels and adjust the tire pressure to the specification.

2.PERFORM ID REGISTRATION

Perform ID registration. Refer to [WT-6. "ID REGISTRATION PROCEDURE : Special Repair Requirement"](#).

>> END

C1724, C1725, C1726, C1727 TRANSMITTER

< DTC/CIRCUIT DIAGNOSIS >

[REGULAR GRADE]

C1724, C1725, C1726, C1727 TRANSMITTER

Description

INFOID:000000005038096

The transmitter integrated with a valve is installed on a wheel, and transmits a detected tire pressure signal by radio wave.

DTC Logic

INFOID:000000005038097

DTC DETECTION LOGIC

DTC	Display item	Malfunction detected condition	Possible case
C1724	[BATT VOLT LOW] FL	Battery voltage of front LH transmitter drops.	<ul style="list-style-type: none">• Transmitter malfunction• Tire pressure receiver malfunction• BCM malfunction• Harness or connector
C1725	[BATT VOLT LOW] FR	Battery voltage of front RH transmitter drops.	
C1726	[BATT VOLT LOW] RR	Battery voltage of rear RH transmitter drops.	
C1727	[BATT VOLT LOW] RL	Battery voltage of rear LH transmitter drops.	

DTC CONFIRMATION PROCEDURE

1. DTC REPRODUCTION PROCEDURE

Ⓜ With CONSULT-III

1. Drive for 3 minutes at a speed of 40 km/h (25 MPH) or more, then drive normally for 10 minutes.
2. Perform BCM (AIR PRESSURE MONITOR) self-diagnosis.

Is DTC "C1724", "C1725", "C1726", "C1727" detected?

- YES >> Perform trouble diagnosis. Refer to [WT-29, "Diagnosis Procedure"](#).
NO >> INSPECTION END

Diagnosis Procedure

INFOID:000000005038098

1. CHECK ID REGISTRATION

Ⓜ With CONSULT-III

1. Perform the ID registration of all transmitters. Refer to [WT-6, "ID REGISTRATION PROCEDURE : Special Repair Requirement"](#).
2. Drive at a 40 km/h (25 MPH) or more, then drive normally for 10 minutes.

Can ID registration of all transmitters be completed?

- YES >> GO TO 2.
NO >> GO TO 5.

2. CHECK TIRE PRESSURE SIGNAL

Ⓜ With CONSULT-III

1. Drive for 3 minutes at a speed of 40 km/h (25 MPH) or more, then drive normally for 10 minutes.
2. On "DATA MONITOR", select "AIR PRESS FL", "AIR PRESS FR", "AIR PRESS RR" and "AIR PRESS RL", and check that the tire pressures match the standard value.

Monitor item	Condition	Displayed value
AIR PRESS FL	Drive for 3 minutes at a speed of 40 km/h (25 MPH) or more, then drive normally for 10 minutes.	Internal pressure of tires
AIR PRESS FR		
AIR PRESS RR		
AIR PRESS RL		

CAUTION:

Stop the vehicle and within 5 minutes, use CONSULT-III "DATA MONITOR" to display the tire pressure for all wheels.

Are all tire pressures displayed 0 kPa?

- YES >> GO TO 3.
NO >> GO TO 6.

C1724, C1725, C1726, C1727 TRANSMITTER

< DTC/CIRCUIT DIAGNOSIS >

[REGULAR GRADE]

3. CHECK HARNESS BETWEEN BCM AND TIRE PRESSURE RECEIVER

1. Turn the ignition switch OFF.
2. Disconnect BCM harness connector and tire pressure receiver harness connector.
3. Check the continuity between BCM harness connector and tire pressure receiver harness connector.

BCM		Tire pressure receiver		Continuity
Connector	Terminal	Connector	Terminal	
M68	18	M13	1	Existed
M71	110		4	
	71		2	

4. Check continuity between BCM harness connector and ground.

BCM		—	Continuity
Connector	Terminal		
M68	18	Ground	Not existed
M71	110		
	71		

Is the inspection result normal?

YES >> GO TO 4.

NO >> Repair or replace damaged parts.

4. CHECK TIRE PRESSURE RECEIVER POWER SUPPLY CIRCUIT

1. Connect the BCM harness connector.
2. Turn the ignition switch ON.
CAUTION:
Never start the engine.
3. Check the voltage between the BCM harness connector and ground.

BCM		—	Voltage
Connector	Terminal		
M68	10	Ground	5 V

Is the inspection result normal?

YES >> GO TO 5.

NO >> Repair or replace damaged parts.

5. CHECK TIRE PRESSURE RECEIVER

Check tire pressure receiver. Refer to [WT-36, "Diagnosis Procedure"](#).

Is the inspection result normal?

YES >> Replace tire pressure receiver. Refer to [WT-96, "Exploded View"](#).

NO >> GO TO 6.

6. CHECK ID REGISTRATION

Perform ID registration of all transmitters. Refer to [WT-6, "ID REGISTRATION PROCEDURE : Special Repair Requirement"](#).

Can ID registration of all transmitters be completed?

YES >> GO TO 7.

NO >> Replace the malfunctioning transmitter. Refer to [WT-94, "Exploded View"](#).

7. CHECK TIRE PRESSURE MONITORING SYSTEM

Ⓟ With CONSULT-III

1. Drive for 3 minutes at a speed of 40 km/h (25 MPH) or more, then drive normally for 10 minutes.
2. On "DATA MONITOR", select "AIR PRESS FL", "AIR PRESS FR", "AIR PRESS RR" and "AIR PRESS RL", and check that the tire pressures match the standard value.

C1724, C1725, C1726, C1727 TRANSMITTER

< DTC/CIRCUIT DIAGNOSIS >

[REGULAR GRADE]

Monitor item	Condition	Displayed value
AIR PRESS FL	Drive for 3 minutes at a speed of 40 km/h (25 MPH) or more, then drive normally for 10 minutes.	Internal pressure of tires
AIR PRESS FR		
AIR PRESS RR		
AIR PRESS RL		

CAUTION:

Stop the vehicle and within 5 minutes, use CONSULT-III "DATA MONITOR" to display the tire pressure for all wheels.

Is the inspection result normal?

YES >> Replace the malfunctioning transmitter. Refer to [WT-94, "Exploded View"](#).

NO >> Replace BCM. Refer to [WT-97, "Tire Air Pressure"](#).

Special Repair Requirement

INFOID:000000005038099

WT

1.CHECK TIRE PRESSURE

Check all tires for tire pressures. Refer to [WT-97, "Tire Air Pressure"](#).

Does all tire pressure data meet the specification?

YES >> GO TO 2.

NO >> Inspect or repair the tires or wheels and adjust the tire pressure to the specification.

2.PERFORM ID REGISTRATION

Perform ID registration. Refer to [WT-6, "ID REGISTRATION PROCEDURE : Special Repair Requirement"](#).

>> END

C1729 VEHICLE SPEED SIGNAL

< DTC/CIRCUIT DIAGNOSIS >

[REGULAR GRADE]

C1729 VEHICLE SPEED SIGNAL

Description

INFOID:000000005038100

BCM detects no vehicle speed signal.

DTC Logic

INFOID:000000005038101

DTC DETECTION LOGIC

DTC number	Trouble diagnosis name	DTC detecting condition	Possible case
C1729	VHCL SPEED SIG ERR	Vehicle speed signal not detected.	<ul style="list-style-type: none">CAN communication errorCombination meter malfunction

DTC CONFIRMATION PROCEDURE

1. DTC REPRODUCTION PROCEDURE

Ⓟ With CONSULT-III

- Drive for several minutes at a speed of 40 km/h (25 MPH) or more, then stop the vehicle.
- Perform BCM (AIR PRESSURE MONITOR) self-diagnosis.

Is DTC "C1729" detected?

- YES >> Perform trouble diagnosis. Refer to [WT-32, "Diagnosis Procedure"](#).
NO >> INSPECTION END

Diagnosis Procedure

INFOID:000000005038102

1. PERFORM COMBINATION METER SELF-DIAGNOSIS

Ⓟ With CONSULT-III

Perform combination meter self-diagnosis.

Is any DTC detected?

- YES >> Check the DTC. Refer to [MWI-62, "DTC Index"](#).
NO >> GO TO 2.

2. PERFORM SELF-DIAGNOSIS

Ⓟ With CONSULT-III

Perform BCM (AIR PRESSURE MONITOR) self-diagnosis.

Is DTC "C1729" detected?

- YES >> Replace BCM. Refer to [WT-11, "COMMON ITEM : CONSULT-III Function \(BCM - COMMON ITEM\)"](#).
NO >> GO TO 3.

3. CHECK INFORMATION

Ⓟ With CONSULT-III

Use CONSULT-III "DATA MONITOR" to check the input/output values. Refer to [WT-45, "Reference Value"](#).

Is the inspection result normal?

- YES >> Check pin terminal and connection of each harness connector for malfunctioning conditions.
NO >> Replace BCM. Refer to [BCS-82, "Exploded View"](#).

Special Repair Requirement

INFOID:000000005038103

1. CHECK TIRE PRESSURE

Check all tires for tire pressures. Refer to [WT-97, "Tire Air Pressure"](#).

Does all tire pressure data meet the specification?

- YES >> GO TO 2.
NO >> Inspect or repair the tires or wheels and adjust the tire pressure to the specification.

C1729 VEHICLE SPEED SIGNAL

< DTC/CIRCUIT DIAGNOSIS >

[REGULAR GRADE]

2.PERFORM ID REGISTRATION

Perform ID registration. Refer to [WT-6, "ID REGISTRATION PROCEDURE : Special Repair Requirement"](#).

>> END

A
B
C
D
WT
F
G
H
I
J
K
L
M
N
O
P

C1734 BCM

Description

INFOID:000000005038104

The BCM reads the tire pressure signal received by the tire pressure receiver, and controls the low tire pressure warning lamp and the buzzer operations. It also has a judgment function to detect a system malfunction.

DTC Logic

INFOID:000000005038105

DTC DETECTION LOGIC

DTC	Display item	Malfunction detected condition	Possible case
C1734	CONTROL UNIT	Tire pressure monitoring system malfunction in BCM	BCM malfunction

DTC CONFIRMATION PROCEDURE

1. DTC REPRODUCTION PROCEDURE

④ With CONSULT-III

1. Drive at a speed of 40 km/h (25 MPH) or more for several minutes without stopping.
2. Perform BCM (AIR PRESSURE MONITOR) self-diagnosis.

CAUTION:

Perform within 15 minutes after stop the vehicle.

Is DTC "C1734" detected?

- YES >> Perform trouble diagnosis. Refer to [WT-34, "Diagnosis Procedure"](#).
 NO >> INSPECTION END

Diagnosis Procedure

INFOID:000000005038106

1. CHECK BCM POWER SUPPLY

1. Turn the ignition switch OFF.
2. Disconnect BCM harness connector.
3. Check voltage between BCM harness connector terminals and ground.

BCM		—	Voltage
Connector	Terminal		
M70	57	Ground	Battery voltage
	70		

Is the power supply normal?

- YES >> GO TO 2.
 NO >> Check the following. If any items are damaged, repair or replace damage parts.
- 40A fusible link [No. G located in the fuse block]. Refer to [PG-91, "Fuse and Fusible Link Arrangement"](#).
 - 10A fuse [No. 8 located in the fuse block (J/B)]. Refer to [PG-90, "Fuse, Connector and Terminal Arrangement"](#).
 - Harness for short or open between battery and BCM harness connector M70 terminal 57 and 70.
 - Check the Battery voltage.

2. CHECK BCM GROUND

Check the continuity between BCM harness connector and ground.

BCM		—	Continuity
Connector	Terminal		
M70	67	Ground	Existed

Is the inspection result normal?

- YES >> GO TO 3.

C1734 BCM

[REGULAR GRADE]

< DTC/CIRCUIT DIAGNOSIS >

NO >> Repair or replace damaged parts.

3.CHECK HARNESS BETWEEN BCM AND TIRE PRESSURE RECEIVER

1. Disconnect tire pressure receiver harness connector.
2. Check the continuity between BCM harness connector and tire pressure receiver harness connector.

BCM		Tire pressure receiver		Continuity
Connector	Terminal	Connector	Terminal	
M68	18	M13	1	Existed
M71	110		4	
	71		2	

3. Check the continuity between BCM harness connector and ground.

BCM		—	Continuity
Connector	Terminal		
M68	18	Ground	Not existed
M71	110		
	71		

Is the inspection result normal?

YES >> GO TO 4.

NO >> Repair or replace damaged parts.

4.CHECK BCM

Check the BCM input/output signal. Refer to [WT-45, "Reference Value"](#).

Is the inspection result normal?

YES >> INSPECTION END

NO >> GO TO 5.

5.CHECK BCM HARNESS CONNECTOR

Check the BCM pin terminals for damage or loose connection with harness connector.

Is the inspection result normal?

YES >> Replace BCM. Refer to [BCS-82, "Exploded View"](#).

NO >> Check for looseness or damage at the harness connector pins of the low tire pressure warning control unit. Repair or replace if necessary.

Special Repair Requirement

INFOID:000000005038107

1.CHECK TIRE PRESSURE

Check all tires for tire pressures. Refer to [WT-97, "Tire Air Pressure"](#).

Does all tire pressure data meet the specification?

YES >> GO TO 2.

NO >> Inspect or repair the tires or wheels and adjust the tire pressure to the specification.

2.PERFORM ID REGISTRATION

Perform ID registration. Refer to [WT-6, "ID REGISTRATION PROCEDURE : Special Repair Requirement"](#).

>> END

TIRE PRESSURE RECEIVER

< DTC/CIRCUIT DIAGNOSIS >

[REGULAR GRADE]

TIRE PRESSURE RECEIVER

Description

INFOID:000000005038108

The tire pressure receiver receives the tire pressure signal transmitted by the transmitter in each wheel.

Component Function Check

INFOID:000000005038109

1. TIRE PRESSURE MONITORING SYSTEM OPERATION

Ⓟ With CONSULT-III

1. Drive for 3 minutes at a speed of 40 km/h (25 MPH) or more, then drive normally for 10 minutes.
2. On "DATA MONITOR", select "AIR PRESS FL", "AIR PRESS FR", "AIR PRESS RR" and "AIR PRESS RL", and check that the tire pressures match the standard value.

Monitor item	Condition	Displayed value
AIR PRESS FL	Drive for 3 minutes at a speed of 40 km/h (25 MPH) or more, then drive normally for 10 minutes.	Internal pressure of tires
AIR PRESS FR		
AIR PRESS RR		
AIR PRESS RL		

CAUTION:

Stop the vehicle and within 5 minutes, use CONSULT-III "DATA MONITOR" to display the tire pressure for all wheels.

Is the inspection result normal?

YES >> INSPECTION END

NO >> Perform trouble diagnosis. Refer to [WT-36, "Diagnosis Procedure"](#).

Diagnosis Procedure

INFOID:000000005038110

1. CHECK TIRE PRESSURE RECEIVER SIGNAL

1. Turn the ignition switch ON.

CAUTION:

Never start the engine.

2. Check tire pressure receiver connector and ground signal with oscilloscope.

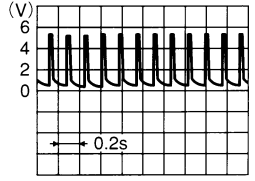
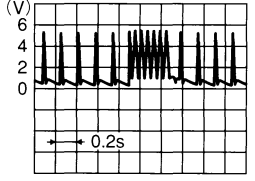
Tire pressure receiver		—	Condition	Voltage (Approx.)
Connector	Terminal			
M13	2	Ground	Stand by state	 <p>OCC3881D</p>
			When receiving the signal from the transmitter	 <p>OCC3880D</p>

Is the inspection result normal?

YES >> INSPECTION END

NO >> GO TO 2.

TIRE PRESSURE RECEIVER

< DTC/CIRCUIT DIAGNOSIS >

[REGULAR GRADE]

2. CHECK TIRE PRESSURE RECEIVER INPUT VOLTAGE

1. Disconnect tire pressure receiver connector.
2. Check voltage between tire pressure receiver connector and ground.

Tire pressure receiver		—	Voltage (Approx.)
Connector	Terminal		
M13	4	Ground	5.0 V

Is the inspection result normal?

- YES >> GO TO 3.
NO >> Repair or replace damaged parts.

3. CHECK TIRE PRESSURE RECEIVER GROUND CIRCUIT

1. Disconnect BCM harness connector.
2. Check continuity between BCM harness connector and tire pressure receiver connector.

BCM		Tire pressure receiver		Continuity
Connector	Terminal	Connector	Terminal	
M68	18	M13	1	Existed

3. Check continuity between BCM harness connector and ground.

BCM		—	Continuity
Connector	Terminal		
M68	18	Ground	Not existed

Is the inspection result normal?

- YES >> GO TO 4.
NO >> Repair or replace damaged parts.

4. CHECK BCM CIRCUIT

Inspect the BCM circuit. Refer to [WT-34, "Diagnosis Procedure"](#).

Is the BCM circuit normal?

- YES >> Replace tire pressure receiver. Refer to [WT-96, "Exploded View"](#).
NO >> Replace BCM. Refer to [BCS-82, "Exploded View"](#).

TIRE PRESSURE WARNING CHECK SWITCH

< DTC/CIRCUIT DIAGNOSIS >

[REGULAR GRADE]

TIRE PRESSURE WARNING CHECK SWITCH

Description

INFOID:000000005038111

Self-diagnosis can be performed by short-circuiting the tire pressure warning check switch to the ground. (Self-diagnosis indicates the location of the malfunction by the blinking of the low tire pressure warning lamp on the combination meter.)

NOTE:

If low tire pressure warning lamp blinks as shown in the figure, the system is normal.

- This mode shows transmitter status is in OFF-mode.
Perform transmitter wake up operation. Refer to [WT-6, "TRANSMITTER WAKE UP OPERATION : Special Repair Requirement"](#).

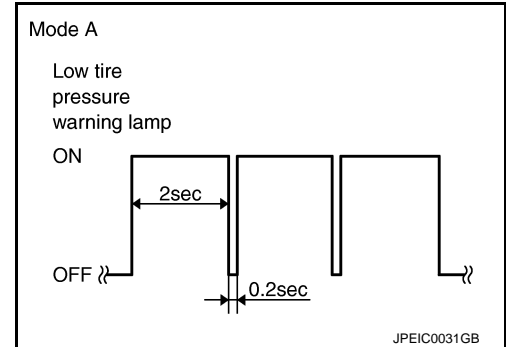

Component Function Check

INFOID:000000005038112

1. CHECK THE ILLUMINATION OF THE LOW TIRE PRESSURE WARNING LAMP

1. Turn the ignition switch ON.
CAUTION:
Never start the engine.
2. Short-circuit the tire pressure warning check switch connector terminal to the ground.
3. Check that the low tire pressure warning lamp blinking.

Is inspection result normal?

- YES >> INSPECTION END
NO >> Perform diagnosis. Refer to [WT-38, "Diagnosis Procedure"](#).

Diagnosis Procedure

INFOID:000000005038113

1. CHECK TIRE PRESSURE WARNING CHECK SWITCH SIGNAL

1. Turn the ignition switch ON.
CAUTION:
Never start the engine.
2. Check the voltage between tire pressure warning check switch connector and ground.

Tire pressure warning check switch		—	Condition	Voltage (Approx.)
Connector	Terminal			
M9	1	Ground	Ignition switch OFF	<p>1.0 - 1.5 V JPMIA0012GB</p>

Is the inspection result normal?

- YES >> Replace BCM. Refer to [BCS-82, "Exploded View"](#).
NO >> GO TO 2.

TIRE PRESSURE WARNING CHECK SWITCH

< DTC/CIRCUIT DIAGNOSIS >

[REGULAR GRADE]

2. CHECK TIRE PRESSURE WARNING CHECK SWITCH CIRCUIT

1. Turn the ignition switch OFF.
2. Disconnect BCM harness connector
3. Check the continuity between BCM harness connector and tire pressure warning check switch connector.

BCM		Tire pressure warning check switch		Continuity
Connector	Terminal	Connector	Terminal	
M68	10	M9	1	Existed

4. Check the continuity between BCM harness connector and ground.

BCM		—	Continuity
Connector	Terminal		
M68	10	Ground	Not existed

Is the inspection result normal?

- YES >> Check BCM pin terminals for damage or loose connection with harness connector. If any items are damaged, repair or replace damaged parts. Replace BCM. Refer to [BCS-82, "Exploded View"](#).
- NO >> Repair or replace damaged parts.

A
B
C
D
WT
F
G
H
I
J
K
L
M
N
O
P

LOW TIRE PRESSURE WARNING LAMP

< DTC/CIRCUIT DIAGNOSIS >

[REGULAR GRADE]

LOW TIRE PRESSURE WARNING LAMP

Description

INFOID:000000005038114

Uses CAN communication from the BCM to illuminate the low tire pressure warning lamp on the combination meter.

Condition	Low tire pressure warning lamp
Ignition switch OFF.	OFF
Ignition switch ON.	Illuminates for 1 second, then turns OFF.
Less than 182.7 kPa (1.9 kg/cm ² , 26 psi) [NOTE]	ON
Tire pressure monitoring system malfunction [Other diagnostic item]	Flashes for 1 minute, then stays illuminated.

NOTE: Standard tire pressure is for 230 kPa (2.3 kg/cm², 33 psi) vehicles.

Component Function Check

INFOID:000000005038115

1. CHECK THE ILLUMINATION OF THE LOW TIRE PRESSURE WARNING LAMP

Check that the low tire pressure warning lamp is turned OFF after illuminating for approximately 1 second, when the ignition switch is turned ON.

Is the inspection result normal?

YES >> INSPECTION END

NO >> Perform trouble diagnosis. Refer to [WT-40, "Diagnosis Procedure"](#).

Diagnosis Procedure

INFOID:000000005038116

1. POWER SUPPLY AND GROUND CIRCUIT

Check power supply and ground circuit. Refer to [WT-41, "Diagnosis Procedure"](#).

Is the inspection result normal?

YES >> GO TO 2.

NO >> Repair or replace damaged parts.

2. PERFORM SELF-DIAGNOSIS

Ⓟ With CONSULT-III

Perform BCM (AIR PRESSURE MONITOR) self-diagnosis.

Is any DTC detected?

YES >> Check the DTC. Refer to [WT-74, "DTC Index"](#).

NO >> GO TO 3.

3. CHECK LOW TIRE PRESSURE WARNING LAMP SIGNAL

Ⓟ With CONSULT-III

1. Turn the ignition switch ON.

CAUTION:

Never start the engine.

2. On "DATA MONITOR", select "WARNING LAMP".

3. Check that the low tire pressure warning lamp is turned OFF after illuminating for approximately 1 second, when the ignition switch is turned ON.

Is the inspection result normal?

YES >> Check the combination meter. Refer to [MWI-39, "COMBINATION METER : Diagnosis Procedure"](#).

NO >> Replace the BCM. Refer to [BCS-82, "Exploded View"](#).

POWER SUPPLY AND GROUND CIRCUIT

< DTC/CIRCUIT DIAGNOSIS >

[REGULAR GRADE]

POWER SUPPLY AND GROUND CIRCUIT

Diagnosis Procedure

INFOID:000000005038117

1. POWER SUPPLY SYSTEM CHECK

1. Turn the ignition switch OFF.
2. Disconnect the BCM harness connector.
3. Turn the ignition switch ON.
CAUTION:
Never start the engine.
4. Check the voltage between the BCM harness connector and the ground.

BCM		—	Voltage
Connector	Terminal		
M70	57	Ground	Battery voltage
	70		

Is the inspection result normal?

- YES >> GO TO 2.
NO >> Repair or replace damaged parts.

2. GROUND SYSTEM INSPECTION

1. Turn the ignition switch OFF.
2. Check the continuity between the BCM harness connector and the ground.

BCM		—	Continuity
Connector	Terminal		
M70	67	Ground	Existed

Is the inspection result normal?

- YES >> • Check the 10 A fuse [No. 8 in fuse block (J/B)].
• Check the 40 A fusible link [No. G in fuse block].
NO >> Repair or replace damaged parts.

A
B
C
D
E
F
G
H
I
J
K
L
M
N
O
P

WT

TPMS

Wiring Diagram - TIRE PRESSURE MONITORING SYSTEM -



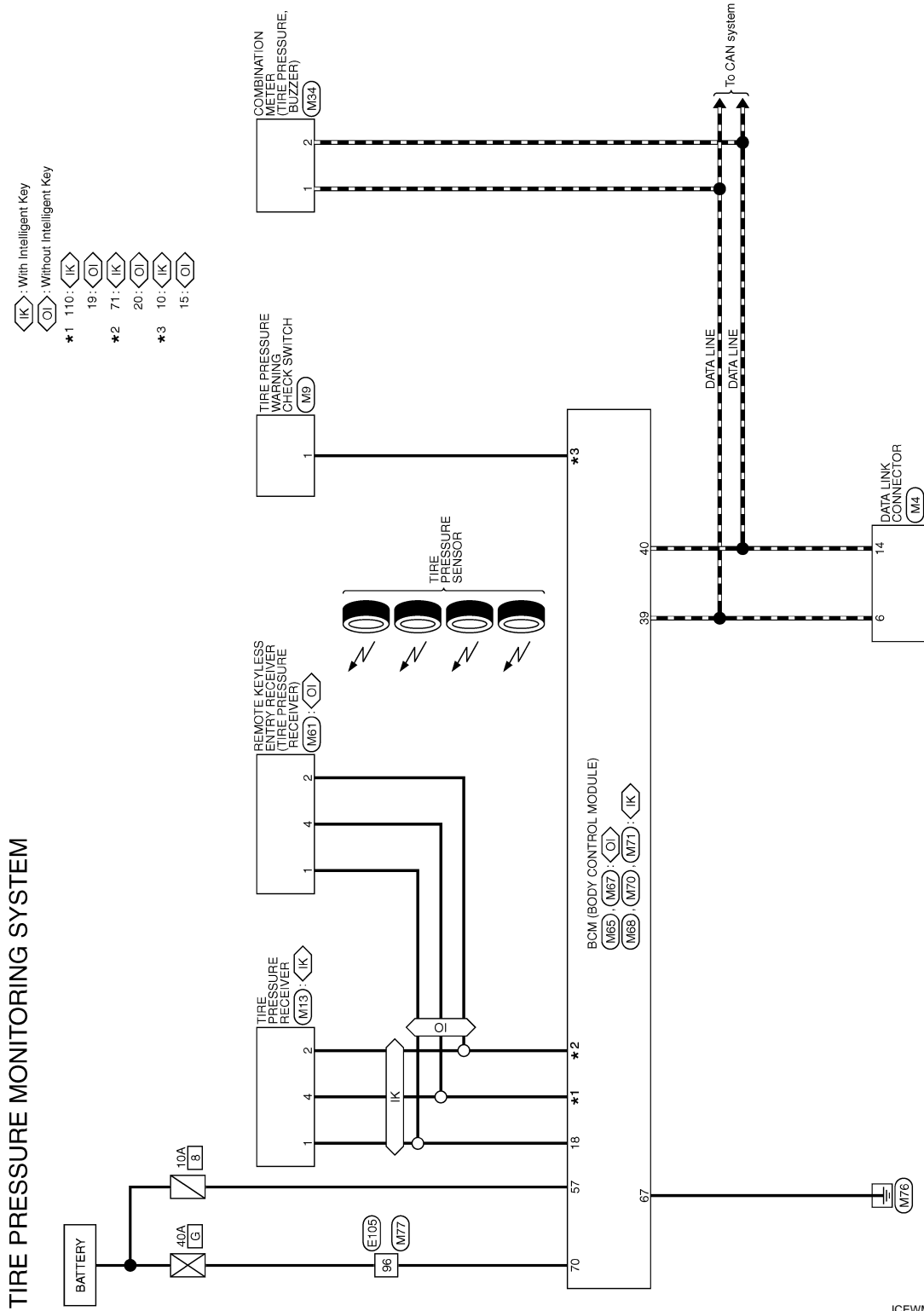





INFOID:000000005038118

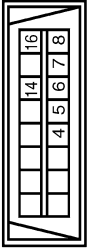

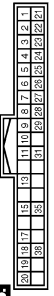
2009/02/27

JCEWM0090GB

TIRE PRESSURE MONITORING SYSTEM

<table border="1" style="width: 100%; border-collapse: collapse;"> <tr> <td>Connector No.</td> <td>M4</td> </tr> <tr> <td>Connector Name</td> <td>DATA LINK CONNECTOR</td> </tr> <tr> <td>Connector Type</td> <td>BD16FW</td> </tr> </table>  <table border="1" style="width: 100%; border-collapse: collapse;"> <tr> <td>Terminal No.</td> <td>6</td> <td>14</td> </tr> <tr> <td>Color of Wire</td> <td>L</td> <td>P</td> </tr> <tr> <td>Signal Name [Specification]</td> <td></td> <td></td> </tr> </table>	Connector No.	M4	Connector Name	DATA LINK CONNECTOR	Connector Type	BD16FW	Terminal No.	6	14	Color of Wire	L	P	Signal Name [Specification]			<table border="1" style="width: 100%; border-collapse: collapse;"> <tr> <td>Connector No.</td> <td>M9</td> </tr> <tr> <td>Connector Name</td> <td>TIRE PRESSURE WARNING SWITCH</td> </tr> <tr> <td>Connector Type</td> <td>TK02FW</td> </tr> </table>  <table border="1" style="width: 100%; border-collapse: collapse;"> <tr> <td>Terminal No.</td> <td>1</td> </tr> <tr> <td>Color of Wire</td> <td>V/W</td> </tr> <tr> <td>Signal Name [Specification]</td> <td></td> </tr> </table>	Connector No.	M9	Connector Name	TIRE PRESSURE WARNING SWITCH	Connector Type	TK02FW	Terminal No.	1	Color of Wire	V/W	Signal Name [Specification]		<table border="1" style="width: 100%; border-collapse: collapse;"> <tr> <td>Connector No.</td> <td>M13</td> </tr> <tr> <td>Connector Name</td> <td>TIRE PRESSURE RECEIVER</td> </tr> <tr> <td>Connector Type</td> <td>TK04FW</td> </tr> </table>  <table border="1" style="width: 100%; border-collapse: collapse;"> <tr> <td>Terminal No.</td> <td>1</td> <td>2</td> <td>4</td> </tr> <tr> <td>Color of Wire</td> <td>V</td> <td>R</td> <td>BR/W</td> </tr> <tr> <td>Signal Name [Specification]</td> <td></td> <td></td> <td></td> </tr> </table>	Connector No.	M13	Connector Name	TIRE PRESSURE RECEIVER	Connector Type	TK04FW	Terminal No.	1	2	4	Color of Wire	V	R	BR/W	Signal Name [Specification]																		
Connector No.	M4																																																													
Connector Name	DATA LINK CONNECTOR																																																													
Connector Type	BD16FW																																																													
Terminal No.	6	14																																																												
Color of Wire	L	P																																																												
Signal Name [Specification]																																																														
Connector No.	M9																																																													
Connector Name	TIRE PRESSURE WARNING SWITCH																																																													
Connector Type	TK02FW																																																													
Terminal No.	1																																																													
Color of Wire	V/W																																																													
Signal Name [Specification]																																																														
Connector No.	M13																																																													
Connector Name	TIRE PRESSURE RECEIVER																																																													
Connector Type	TK04FW																																																													
Terminal No.	1	2	4																																																											
Color of Wire	V	R	BR/W																																																											
Signal Name [Specification]																																																														
<table border="1" style="width: 100%; border-collapse: collapse;"> <tr> <td>Connector No.</td> <td>M34</td> </tr> <tr> <td>Connector Name</td> <td>COMBINATION METER</td> </tr> <tr> <td>Connector Type</td> <td>TH40FW-NH</td> </tr> </table>  <table border="1" style="width: 100%; border-collapse: collapse;"> <tr> <td>Terminal No.</td> <td>1</td> <td>2</td> </tr> <tr> <td>Color of Wire</td> <td>L</td> <td>P</td> </tr> <tr> <td>Signal Name [Specification]</td> <td>CAN-H</td> <td>CAN-L</td> </tr> </table>	Connector No.	M34	Connector Name	COMBINATION METER	Connector Type	TH40FW-NH	Terminal No.	1	2	Color of Wire	L	P	Signal Name [Specification]	CAN-H	CAN-L	<table border="1" style="width: 100%; border-collapse: collapse;"> <tr> <td>Connector No.</td> <td>M65</td> </tr> <tr> <td>Connector Name</td> <td>BCM (BODY CONTROL MODULE) RECEIVER/SENSOR GND</td> </tr> <tr> <td>Connector Type</td> <td>TH40FW-NH</td> </tr> </table>  <table border="1" style="width: 100%; border-collapse: collapse;"> <tr> <td>Terminal No.</td> <td>15</td> <td>18</td> <td>19</td> <td>20</td> <td>38</td> <td>40</td> </tr> <tr> <td>Color of Wire</td> <td>V/W</td> <td>V</td> <td>BR</td> <td>G/Y</td> <td>L</td> <td>P</td> </tr> <tr> <td>Signal Name [Specification]</td> <td>TIRE PRESS WARNING CHECK SW</td> <td>RECEIVER/SENSOR GND</td> <td>KEYLESS ENTRY RECEIVER POWER SUPPLY</td> <td>KEYLESS ENTRY RECEIVER COMM</td> <td>CAN-H</td> <td>CAN-L</td> </tr> </table>	Connector No.	M65	Connector Name	BCM (BODY CONTROL MODULE) RECEIVER/SENSOR GND	Connector Type	TH40FW-NH	Terminal No.	15	18	19	20	38	40	Color of Wire	V/W	V	BR	G/Y	L	P	Signal Name [Specification]	TIRE PRESS WARNING CHECK SW	RECEIVER/SENSOR GND	KEYLESS ENTRY RECEIVER POWER SUPPLY	KEYLESS ENTRY RECEIVER COMM	CAN-H	CAN-L	<table border="1" style="width: 100%; border-collapse: collapse;"> <tr> <td>Connector No.</td> <td>M67</td> </tr> <tr> <td>Connector Name</td> <td>BCM (BODY CONTROL MODULE) (WITHOUT INTELLIGENT KEY)</td> </tr> <tr> <td>Connector Type</td> <td>FEA09FB-FHA6-SA</td> </tr> </table>  <table border="1" style="width: 100%; border-collapse: collapse;"> <tr> <td>Terminal No.</td> <td>57</td> <td>67</td> <td>70</td> </tr> <tr> <td>Color of Wire</td> <td>Y</td> <td>B</td> <td>Y</td> </tr> <tr> <td>Signal Name [Specification]</td> <td>BAT (FUSE)</td> <td>GND</td> <td>BAT (F/L)</td> </tr> </table>	Connector No.	M67	Connector Name	BCM (BODY CONTROL MODULE) (WITHOUT INTELLIGENT KEY)	Connector Type	FEA09FB-FHA6-SA	Terminal No.	57	67	70	Color of Wire	Y	B	Y	Signal Name [Specification]	BAT (FUSE)	GND	BAT (F/L)
Connector No.	M34																																																													
Connector Name	COMBINATION METER																																																													
Connector Type	TH40FW-NH																																																													
Terminal No.	1	2																																																												
Color of Wire	L	P																																																												
Signal Name [Specification]	CAN-H	CAN-L																																																												
Connector No.	M65																																																													
Connector Name	BCM (BODY CONTROL MODULE) RECEIVER/SENSOR GND																																																													
Connector Type	TH40FW-NH																																																													
Terminal No.	15	18	19	20	38	40																																																								
Color of Wire	V/W	V	BR	G/Y	L	P																																																								
Signal Name [Specification]	TIRE PRESS WARNING CHECK SW	RECEIVER/SENSOR GND	KEYLESS ENTRY RECEIVER POWER SUPPLY	KEYLESS ENTRY RECEIVER COMM	CAN-H	CAN-L																																																								
Connector No.	M67																																																													
Connector Name	BCM (BODY CONTROL MODULE) (WITHOUT INTELLIGENT KEY)																																																													
Connector Type	FEA09FB-FHA6-SA																																																													
Terminal No.	57	67	70																																																											
Color of Wire	Y	B	Y																																																											
Signal Name [Specification]	BAT (FUSE)	GND	BAT (F/L)																																																											
<table border="1" style="width: 100%; border-collapse: collapse;"> <tr> <td>Connector No.</td> <td>M61</td> </tr> <tr> <td>Connector Name</td> <td>REMOTE KEYLESS ENTRY RECEIVER (WITHOUT INTELLIGENT KEY)</td> </tr> <tr> <td>Connector Type</td> <td>TK04FW</td> </tr> </table>  <table border="1" style="width: 100%; border-collapse: collapse;"> <tr> <td>Terminal No.</td> <td>1</td> <td>2</td> <td>4</td> </tr> <tr> <td>Color of Wire</td> <td>V</td> <td>G/Y</td> <td>BR</td> </tr> <tr> <td>Signal Name [Specification]</td> <td></td> <td></td> <td></td> </tr> </table>	Connector No.	M61	Connector Name	REMOTE KEYLESS ENTRY RECEIVER (WITHOUT INTELLIGENT KEY)	Connector Type	TK04FW	Terminal No.	1	2	4	Color of Wire	V	G/Y	BR	Signal Name [Specification]				<table border="1" style="width: 100%; border-collapse: collapse;"> <tr> <td>Connector No.</td> <td>M67</td> </tr> <tr> <td>Connector Name</td> <td>BCM (BODY CONTROL MODULE) (WITHOUT INTELLIGENT KEY)</td> </tr> <tr> <td>Connector Type</td> <td>FEA09FB-FHA6-SA</td> </tr> </table>  <table border="1" style="width: 100%; border-collapse: collapse;"> <tr> <td>Terminal No.</td> <td>57</td> <td>67</td> <td>70</td> </tr> <tr> <td>Color of Wire</td> <td>Y</td> <td>B</td> <td>Y</td> </tr> <tr> <td>Signal Name [Specification]</td> <td>BAT (FUSE)</td> <td>GND</td> <td>BAT (F/L)</td> </tr> </table>	Connector No.	M67	Connector Name	BCM (BODY CONTROL MODULE) (WITHOUT INTELLIGENT KEY)	Connector Type	FEA09FB-FHA6-SA	Terminal No.	57	67	70	Color of Wire	Y	B	Y	Signal Name [Specification]	BAT (FUSE)	GND	BAT (F/L)	<table border="1" style="width: 100%; border-collapse: collapse;"> <tr> <td>Connector No.</td> <td>M61</td> </tr> <tr> <td>Connector Name</td> <td>REMOTE KEYLESS ENTRY RECEIVER (WITHOUT INTELLIGENT KEY)</td> </tr> <tr> <td>Connector Type</td> <td>TK04FW</td> </tr> </table>  <table border="1" style="width: 100%; border-collapse: collapse;"> <tr> <td>Terminal No.</td> <td>1</td> <td>2</td> <td>4</td> </tr> <tr> <td>Color of Wire</td> <td>V</td> <td>G/Y</td> <td>BR</td> </tr> <tr> <td>Signal Name [Specification]</td> <td></td> <td></td> <td></td> </tr> </table>	Connector No.	M61	Connector Name	REMOTE KEYLESS ENTRY RECEIVER (WITHOUT INTELLIGENT KEY)	Connector Type	TK04FW	Terminal No.	1	2	4	Color of Wire	V	G/Y	BR	Signal Name [Specification]									
Connector No.	M61																																																													
Connector Name	REMOTE KEYLESS ENTRY RECEIVER (WITHOUT INTELLIGENT KEY)																																																													
Connector Type	TK04FW																																																													
Terminal No.	1	2	4																																																											
Color of Wire	V	G/Y	BR																																																											
Signal Name [Specification]																																																														
Connector No.	M67																																																													
Connector Name	BCM (BODY CONTROL MODULE) (WITHOUT INTELLIGENT KEY)																																																													
Connector Type	FEA09FB-FHA6-SA																																																													
Terminal No.	57	67	70																																																											
Color of Wire	Y	B	Y																																																											
Signal Name [Specification]	BAT (FUSE)	GND	BAT (F/L)																																																											
Connector No.	M61																																																													
Connector Name	REMOTE KEYLESS ENTRY RECEIVER (WITHOUT INTELLIGENT KEY)																																																													
Connector Type	TK04FW																																																													
Terminal No.	1	2	4																																																											
Color of Wire	V	G/Y	BR																																																											
Signal Name [Specification]																																																														

A
B
C
D
WT
F
G
H
I
J
K
L
M
N
O
P

TIRE PRESSURE MONITORING SYSTEM

Connector No.	M68
Connector Name	BCM (BODY CONTROL MODULE) (WITH INTELLIGENT KEY)
Connector Type	TH40FB-NH

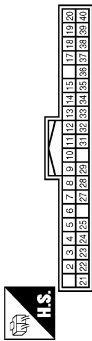

Terminal No.	Color of Wire	Signal Name [Specification]
10	V/W	TIRE PRESS WARNING CHECK SW
18	V	TIRE PRESS RECEIVER CHECK SW
38	L	RECEIVER/SENSOR GND
40	P	CAN-H
		CAN-L

Connector No.	M70
Connector Name	BCM (BODY CONTROL MODULE) (WITH INTELLIGENT KEY)
Connector Type	FE40BFB-FH4G-SA



Terminal No.	Color of Wire	Signal Name [Specification]
57	Y	BAT (FUSE)
67	B	GND
70	Y	BAT (F/L)

Connector No.	M71
Connector Name	BCM (BODY CONTROL MODULE) (WITH INTELLIGENT KEY)
Connector Type	TH40FW-NH

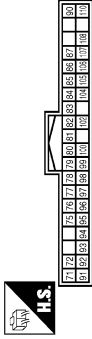

Terminal No.	Color of Wire	Signal Name [Specification]
71	R	TIRE PRESS RECEIVER COMM
110	BR/W	TIRE PRESS POWER SUPPLY

Connector No.	M77
Connector Name	WIRE TO WIRE
Connector Type	TH80FPW-CS (P-TM4)

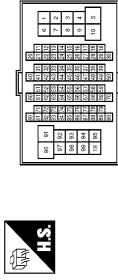

Terminal No.	Color of Wire	Signal Name [Specification]
96	Y	

JCEWM0092GB

BCM (BODY CONTROL MODULE)

< ECU DIAGNOSIS INFORMATION >

[REGULAR GRADE]

ECU DIAGNOSIS INFORMATION

BCM (BODY CONTROL MODULE)

Reference Value

INFOID:0000000005072099

VALUES ON THE DIAGNOSIS TOOL

CONSULT-III MONITOR ITEM

Monitor Item	Condition	Value/Status
FR WIPER HI	Other than front wiper switch HI	Off
	Front wiper switch HI	On
FR WIPER LOW	Other than front wiper switch LO	Off
	Front wiper switch LO	On
FR WASHER SW	Front washer switch OFF	Off
	Front washer switch ON	On
FR WIPER INT	Other than front wiper switch INT/AUTO	Off
	Front wiper switch INT/AUTO	On
FR WIPER STOP	Front wiper is not in STOP position	Off
	Front wiper is in STOP position	On
INT VOLUME	Wiper intermittent dial is in a dial position 1 - 7	Wiper intermittent dial position
RR WIPER ON	Other than rear wiper switch ON	Off
	Rear wiper switch ON	On
RR WIPER INT	Other than rear wiper switch INT	Off
	Rear wiper switch INT	On
RR WASHER SW	Rear washer switch OFF	Off
	Rear washer switch ON	On
RR WIPER STOP	Rear wiper is in STOP position	Off
	Rear wiper is not in STOP position	On
TURN SIGNAL R	Other than turn signal switch RH	Off
	Turn signal switch RH	On
TURN SIGNAL L	Other than turn signal switch LH	Off
	Turn signal switch LH	On
TAIL LAMP SW	Other than lighting switch 1ST and 2ND	Off
	Lighting switch 1ST or 2ND	On
HI BEAM SW	Other than lighting switch HI	Off
	Lighting switch HI	On
HEAD LAMP SW 1	Other than lighting switch 2ND	Off
	Lighting switch 2ND	On
HEAD LAMP SW 2	Other than lighting switch 2ND	Off
	Lighting switch 2ND	On
PASSING SW	Other than lighting switch PASS	Off
	Lighting switch PASS	On
AUTO LIGHT SW	Other than lighting switch AUTO	Off
	Lighting switch AUTO	On
FR FOG SW	Front fog lamp switch OFF	Off
	Front fog lamp switch ON	On

BCM (BODY CONTROL MODULE)

< ECU DIAGNOSIS INFORMATION >

[REGULAR GRADE]

Monitor Item	Condition	Value/Status
DOOR SW-DR	Driver door closed	Off
	Driver door opened	On
DOOR SW-AS	Passenger door closed	Off
	Passenger door opened	On
DOOR SW-RR	Rear RH door closed	Off
	Rear RH door opened	On
DOOR SW-RL	Rear LH door closed	Off
	Rear LH door opened	On
DOOR SW-BK	Back door closed	Off
	Back door opened	On
CDL LOCK SW	Other than power door lock switch LOCK	Off
	Power door lock switch LOCK	On
CDL UNLOCK SW	Other than power door lock switch UNLOCK	Off
	Power door lock switch UNLOCK	On
KEY CYL LK-SW	Other than driver door key cylinder LOCK position	Off
	Driver door key cylinder LOCK position	On
KEY CYL UN-SW	Other than driver door key cylinder UNLOCK position	Off
	Driver door key cylinder UNLOCK position	On
HAZARD SW	Hazard switch is OFF	Off
	Hazard switch is ON	On
REAR DEF SW	Rear window defogger switch OFF	Off
	Rear window defogger switch ON	On
TR/BD OPEN SW	NOTE: The item is indicated, but not monitored.	Off
TRNK/HAT MNTR	NOTE: The item is indicated, but not monitored.	Off
FAN ON SIG	Blower fan OFF	Off
	Blower fan ON	On
AIR COND SW	Air conditioner OFF (A/C switch indicator OFF)	Off
	Air conditioner ON (A/C switch indicator ON)	On
RKE-LOCK	LOCK button of the key is not pressed	Off
	LOCK button of the key is pressed	On
RKE-UNLOCK	UNLOCK button of the key is not pressed	Off
	UNLOCK button of the key is pressed	On
RKE-TR/BD	BACK DOOR OPEN button of the key is not pressed	Off
	BACK DOOR OPEN button of the key is pressed	On
RKE-PANIC	PANIC button of the key is not pressed	Off
	PANIC button of the key is pressed	On
RKE-MODE CHG	LOCK/UNLOCK button of the key is not pressed and held simultaneously	Off
	LOCK/UNLOCK button of the key is pressed and held simultaneously	On
OPTI SEN (DTCT)	Bright outside of the vehicle	Close to 5 V
	Dark outside of the vehicle	Close to 0 V
OPTI SEN (FILT)	Bright outside of the vehicle (Lighting switch AUTO)	Close to 5 V
	Dark outside of the vehicle (Lighting switch AUTO)	Close to 1.50 V

BCM (BODY CONTROL MODULE)

< ECU DIAGNOSIS INFORMATION >

[REGULAR GRADE]

Monitor Item	Condition	Value/Status	
OPTICAL SENSOR	NOTE: The item is indicated, but not monitored.	Off	A
RAIN SENSOR	NOTE: The item is indicated, but not monitored.	Off	B
REQ SW -DR	Driver door request switch is not pressed	Off	C
	Driver door request switch is pressed	On	
REQ SW -AS	Passenger door request switch is not pressed	Off	D
	Passenger door request switch is pressed	On	
REQ SW -RR	NOTE: The item is indicated, but not monitored.	Off	D
REQ SW -RL	NOTE: The item is indicated, but not monitored.	Off	WT
REQ SW -BD/TR	Back door request switch is not pressed	Off	F
	Back door request switch is pressed	On	
PUSH SW	Push-button ignition switch (push switch) is not pressed	Off	F
	Push-button ignition switch (push switch) is pressed	On	
CLUCH SW	NOTE: The item is indicated, but not monitored.	Off	G
BRAKE SW 1	The brake pedal is not depressed	Off	H
	The brake pedal is depressed	On	
BRAKE SW 2	The brake pedal is depressed when No. 7 fuse is blown	Off	I
	The brake pedal is not depressed when No. 7 fuse is blown, or No. 7 fuse is normal	On	
DETE/CANCL SW	Selector lever in P position	Off	J
	Selector lever in any position other than P	On	
SFT PN/N SW	Selector lever in any position other than P and N	Off	K
	Selector lever in P or N position	On	
S/L -LOCK	Steering is locked	Off	L
	Steering is unlocked	On	
S/L -UNLOCK	Steering is unlocked	Off	M
	Steering is locked	On	
S/L RELAY-F/B	Steering is unlocked	Off	N
	Steering is locked	On	
UNLK SEN -DR	Driver door is locked	Off	O
	Driver door is unlocked	On	
PUSH SW -IPDM	Push-button ignition switch (push-switch) is not pressed	Off	P
	Push-button ignition switch (push-switch) is pressed	On	
IGN RLY1 -F/B	Ignition switch in OFF or ACC position	Off	P
	Ignition switch in ON position	On	
DETE SW -IPDM	Selector lever in any position other than P	Off	P
	Selector lever in P position	On	
SFT PN -IPDM	Selector lever in any position other than P and N	Off	P
	Selector lever in P or N position	On	
SFT P -MET	Selector lever in any position other than P	Off	P
	Selector lever in P position	On	

BCM (BODY CONTROL MODULE)

< ECU DIAGNOSIS INFORMATION >

[REGULAR GRADE]

Monitor Item	Condition	Value/Status
SFT N -MET	Selector lever in any position other than N	Off
	Selector lever in N position	On
ENGINE STATE	Engine stopped	Stop
	While the engine stalls	Stall
	At engine cranking	Crank
	Engine running	Run
S/L LOCK-IPDM	Steering is locked	Off
	Steering is unlocked	On
S/L UNLK-IPDM	Steering is unlocked	Off
	Steering is locked	On
S/L RELAY-REQ	Steering is unlocked	Off
	Steering is locked	On
VEH SPEED 1	While driving	Equivalent to speedometer reading
VEH SPEED 2	While driving	Equivalent to speedometer reading
DOOR STAT-DR	Driver door is locked	LOCK
	Wait with selective UNLOCK operation (5 seconds)	READY
	Driver door is unlocked	UNLOCK
DOOR STAT-AS	Passenger door is locked	LOCK
	Wait with selective UNLOCK operation (5 seconds)	READY
	Passenger door is unlocked	UNLOCK
ID OK FLAG	Steering is locked	Reset
	Steering is unlocked	Set
PRMT ENG STRT	The engine start is prohibited	Reset
	The engine start is permitted	Set
PRMT RKE STRT	NOTE: The item is indicated, but not monitored.	Reset
RKE OPE COUN1	During the operation of the key	Operation frequency of the key
RKE OPE COUN2	NOTE: The item is indicated, but not monitored.	—
CONFIRM ID ALL	The key ID that the key slot receives is not recognized by any key ID registered to BCM.	Yet
	The key ID that the key slot receives is recognized by any key ID registered to BCM.	Done
CONFIRM ID4	The key ID that the key slot receives is not recognized by the fourth key ID registered to BCM.	Yet
	The key ID that the key slot receives is recognized by the fourth key ID registered to BCM.	Done
CONFIRM ID3	The key ID that the key slot receives is not recognized by the third key ID registered to BCM.	Yet
	The key ID that the key slot receives is recognized by the third key ID registered to BCM.	Done
CONFIRM ID2	The key ID that the key slot receives is not recognized by the second key ID registered to BCM.	Yet
	The key ID that the key slot receives is recognized by the second key ID registered to BCM.	Done

BCM (BODY CONTROL MODULE)

< ECU DIAGNOSIS INFORMATION >

[REGULAR GRADE]

Monitor Item	Condition	Value/Status	
CONFIRM ID1	The key ID that the key slot receives is not recognized by the first key ID registered to BCM.	Yet	A
	The key ID that the key slot receives is recognized by the first key ID registered to BCM.	Done	B
NOT REGISTERED	BCM detects registered key ID, or BCM does not detect key ID.	ID OK	
	BCM detects non-registration key ID.	ID NG	C
TP 4	The ID of fourth key is not registered to BCM	Yet	
	The ID of fourth key is registered to BCM	Done	
TP 3	The ID of third key is not registered to BCM	Yet	D
	The ID of third key is registered to BCM	Done	
TP 2	The ID of second key is not registered to BCM	Yet	WT
	The ID of second key is registered to BCM	Done	
TP 1	The ID of first key is not registered to BCM	Yet	
	The ID of first key is registered to BCM	Done	F
AIR PRESS FL	Ignition switch ON (Only when the signal from the transmitter is received)	Air pressure of front LH tire	
AIR PRESS FR	Ignition switch ON (Only when the signal from the transmitter is received)	Air pressure of front RH tire	G
AIR PRESS RR	Ignition switch ON (Only when the signal from the transmitter is received)	Air pressure of rear RH tire	H
AIR PRESS RL	Ignition switch ON (Only when the signal from the transmitter is received)	Air pressure of rear LH tire	
ID REGST FL1	ID of front LH tire transmitter is registered	Done	I
	ID of front LH tire transmitter is not registered	Yet	
ID REGST FR1	ID of front RH tire transmitter is registered	Done	J
	ID of front RH tire transmitter is not registered	Yet	
ID REGST RR1	ID of rear RH tire transmitter is registered	Done	
	ID of rear RH tire transmitter is not registered	Yet	K
ID REGST RL1	ID of rear LH tire transmitter is registered	Done	
	ID of rear LH tire transmitter is not registered	Yet	L
WARNING LAMP	Tire pressure indicator OFF	Off	
	Tire pressure indicator ON	On	
BUZZER	Tire pressure warning alarm is not sounding	Off	M
	Tire pressure warning alarm is sounding	On	

N
O
P

BCM (BODY CONTROL MODULE)

< ECU DIAGNOSIS INFORMATION >

[REGULAR GRADE]

TERMINAL LAYOUT

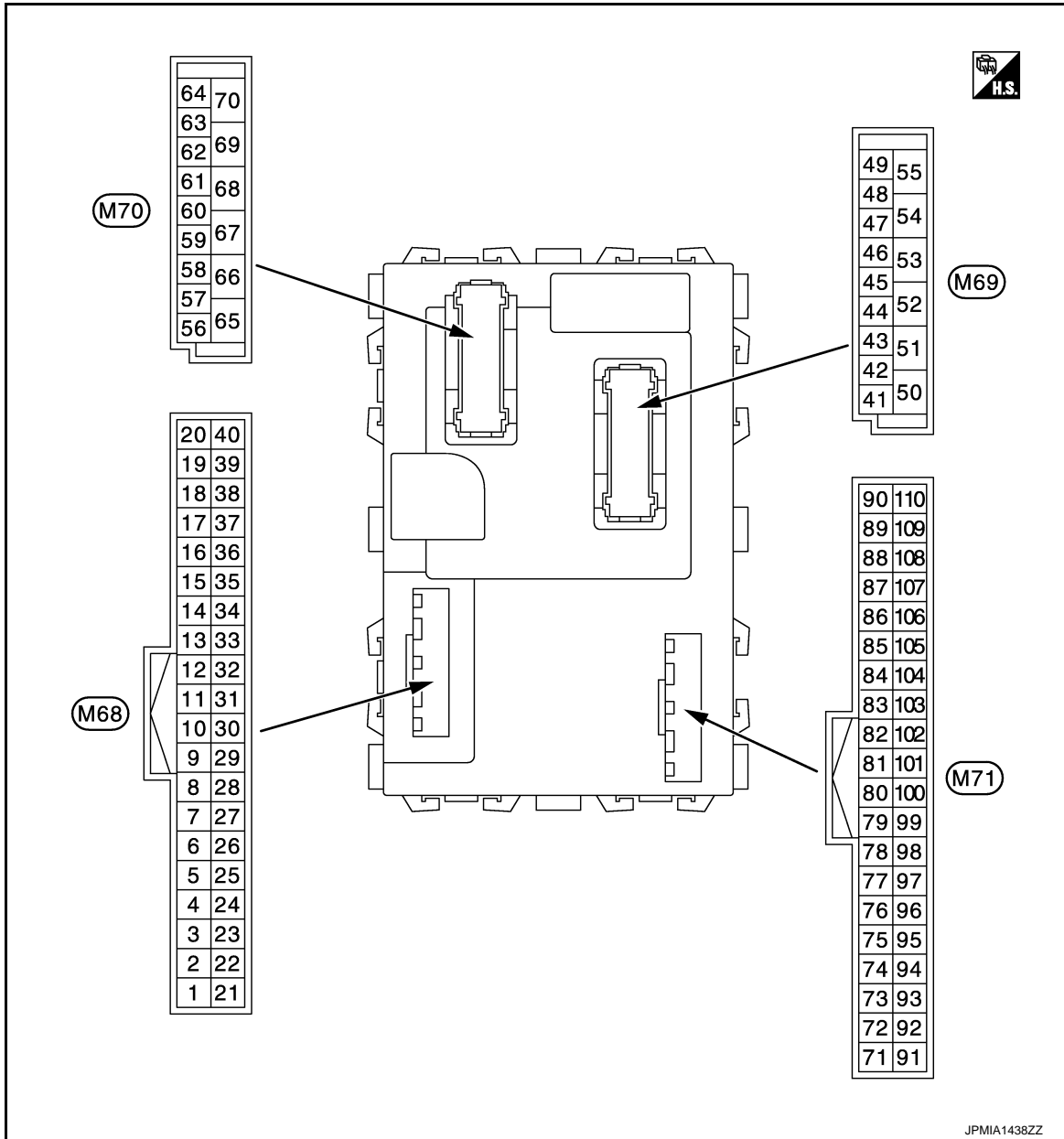

NOTE:

- Connector color
- M68, M70: Black
- M69, M71: White

PHYSICAL VALUES

BCM (BODY CONTROL MODULE)

< ECU DIAGNOSIS INFORMATION >

[REGULAR GRADE]

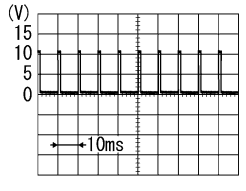
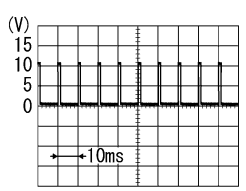
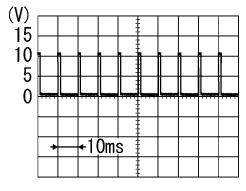
Terminal No. (Wire color)		Description		Condition	Value (Approx.)	
		Signal name	Input/ Output			
+	-					
2 (BR/W)	Ground	Combination switch INPUT 5	Input	Combination switch (Wiper intermit- tent dial 4)	All switch OFF	0 V
					Turn signal switch RH	
					Lighting switch HI	
					Lighting switch 1ST	
					Lighting switch 2ND	
3 (GR)	Ground	Combination switch INPUT 4	Input	Combination switch (Wiper intermit- tent dial 4)	All switch OFF	0 V
					Turn signal switch LH	
					Lighting switch PASS	
					Lighting switch 2ND	
					Front fog lamp switch ON	
4 (L/Y)	Ground	Combination switch INPUT 3	Input	Combination switch (Wiper intermit- tent dial 4)	All switch OFF	0 V
					Front wiper switch LO	
					Front wiper switch MIST	
					Front wiper switch INT	
					Lighting switch AUTO	

A
B
C
D
WT
F
G
H
I
J
K
L
M
N
O
P

BCM (BODY CONTROL MODULE)

< ECU DIAGNOSIS INFORMATION >

[REGULAR GRADE]

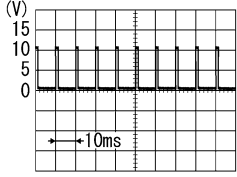
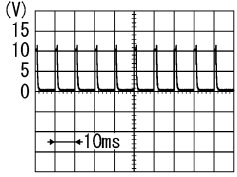
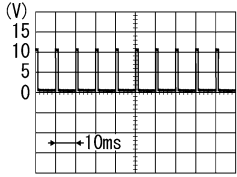
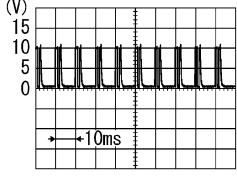
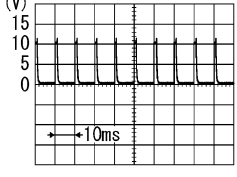
Terminal No. (Wire color)		Description		Condition	Value (Approx.)		
+	-	Signal name	Input/ Output				
5 (G)	Ground	Combination switch INPUT 2	Input	Combination switch	All switch OFF (Wiper intermittent dial 4)	0 V	
					Front washer switch (Wiper intermittent dial 4)		
					Rear washer ON (Wiper intermittent dial 4)		
					Any of the condition below with all switch OFF <ul style="list-style-type: none"> • Wiper intermittent dial 1 • Wiper intermittent dial 5 • Wiper intermittent dial 6 		1.0 V
					Rear wiper switch ON (Wiper intermittent dial 4)		0.8 V
6 (L/R)	Ground	Combination switch INPUT 1	Input	Combination switch	All switch OFF (Wiper intermittent dial 4)	0 V	
					Front wiper switch HI (Wiper intermittent dial 4)		
					Rear wiper switch INT (Wiper intermittent dial 4)		
					Wiper intermittent dial 3 (All switch OFF)		1.0 V
					Any of the condition below with all switch OFF <ul style="list-style-type: none"> • Wiper intermittent dial 1 • Wiper intermittent dial 2 		1.9 V
					Any of the condition below with all switch OFF <ul style="list-style-type: none"> • Wiper intermittent dial 6 • Wiper intermittent dial 7 		0.8 V

BCM (BODY CONTROL MODULE)

< ECU DIAGNOSIS INFORMATION >

[REGULAR GRADE]

Terminal No. (Wire color)		Description		Condition	Value (Approx.)
+	-	Signal name	Input/ Output		
7 (W/R)	Ground	Door key cylinder switch UNLOCK	Input	Door key cylinder switch	NEUTRAL position
				UNLOCK position	8.0 - 8.5 V
8 (W/B)	Ground	Door key cylinder switch LOCK	Input	Door key cylinder switch	NEUTRAL position
				LOCK position	0 V
9 (R)	Ground	Stop lamp switch 1	Input	Stop lamp switch	OFF (Brake pedal is not depressed)
				ON (Brake pedal is de- pressed)	Battery voltage
10 (V/W)	Ground	Tire pressure warn- ing check switch	Input	Ignition switch OFF	Ignition switch OFF
					Ignition switch ACC or ON
12 (SB)	Ground	Passenger door switch	Input	Passenger door switch	OFF (When passenger door closed)
				ON (When passenger door opened)	0 V
13 (GR/L)	Ground	Rear RH door switch	Input	Rear RH door switch	OFF (When rear RH door closed)
				ON (When rear RH door opened)	0 V
14 (L/B)	Ground	Optical sensor	Input	Ignition switch ON	When bright outside of the vehicle
				When dark outside of the vehicle	Close to 0 V

A
B
C
D
WT
F
G
H
I
J
K
L
M
N
O
P

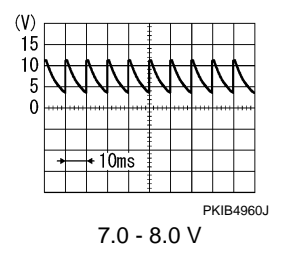
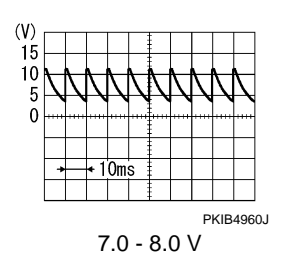
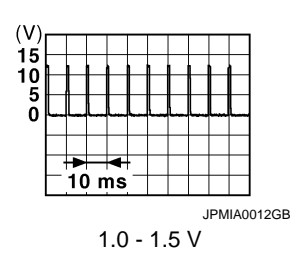
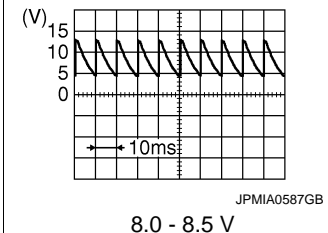

BCM (BODY CONTROL MODULE)

< ECU DIAGNOSIS INFORMATION >

[REGULAR GRADE]

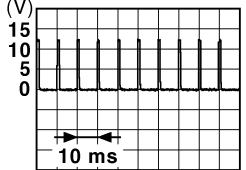
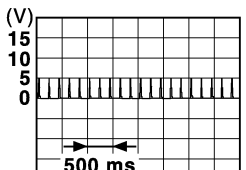
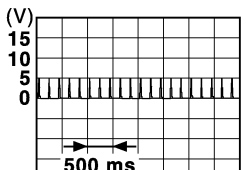
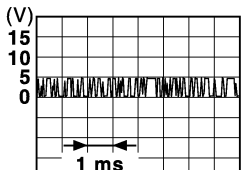
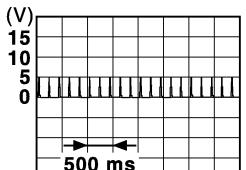
Terminal No. (Wire color)		Description		Condition		Value (Approx.)
+	-	Signal name	Input/ Output			
15 (W/L)	Ground	Rear window defogger switch	Input	Rear window defogger switch	Not pressed	 <small>JPMIA0012GB</small> 1.0 - 1.5 V
					Pressed	0 V
17 (R/G)	Ground	Optical sensor power supply	Output	Ignition switch	OFF, ACC	0 V
					ON	5 V
18 (V)	Ground	Receiver and sensor ground	Input	Ignition switch ON		0 V
19 (BR)	Ground	Remote keyless entry receiver power supply	Output	Ignition switch OFF		 <small>JMKIA3838GB</small>
20 (G/Y)	Ground	Remote keyless entry receiver communication	Input	Waiting		 <small>JMKIA3838GB</small>
				Signal receiving		 <small>JMKIA3841GB</small>
21 (P/L)	Ground	NATS antenna amp.	Input/ Output	During waiting	Ignition switch is pressed while inserting the key into the key slot.	Just after pressing ignition switch. Pointer of tester should move.
22 (W/G)	Ground	Remote keyless entry receiver RSSI	Input	Waiting		0 V
				Signal receiving		 <small>JMKIA3838GB</small>

BCM (BODY CONTROL MODULE)

< ECU DIAGNOSIS INFORMATION >

[REGULAR GRADE]

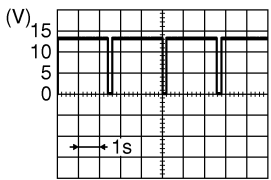
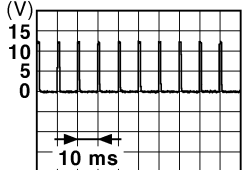
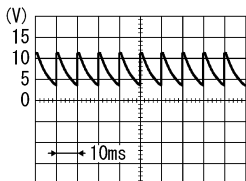
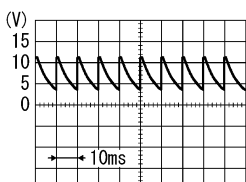
Terminal No. (Wire color)		Description		Condition	Value (Approx.)	
+	-	Signal name	Input/ Output			
23 (R/Y)	Ground	Security indicator lamp	Output	Security indicator	ON	0 V
				Blinking (Ignition switch OFF)	 <p style="text-align: center;">12.0 V</p>	
				OFF	Battery voltage	
24* (GR/R)	Ground	Dongle link	Input/ Output	Ignition switch OFF	5 V	
25 (LG)	Ground	NATS antenna amp.	Input/ Output	During waiting	Ignition switch is pressed while inserting the key into the key slot. Just after pressing ignition switch. Pointer of tester should move.	
27 (Y/G)	Ground	A/C switch	Input	Air conditioner	OFF (A/C switch indicator: OFF)	 <p style="text-align: center;">1.0 - 1.5 V</p>
				ON (A/C switch indicator: ON)	0 V	
28 (G/W)	Ground	Blower fan switch	Input	Blower fan	OFF	0 V
				ON	 <p style="text-align: center;">7.0 - 8.0 V</p>	
29 (L/W)	Ground	Hazard switch	Input	Hazard switch	OFF	12 V
				ON	0 V	
31 (G/B)	Ground	Front door lock assembly driver side (Unlock sensor)	Input	Driver door	LOCK status (Unlock sensor switch OFF)	 <p style="text-align: center;">7.0 - 8.0 V</p>
				UNLOCK status (Unlock sensor switch ON)	0 V	

A
B
C
D
WT
F
G
H
I
J
K
L
M
N
O
P

BCM (BODY CONTROL MODULE)

< ECU DIAGNOSIS INFORMATION >

[REGULAR GRADE]

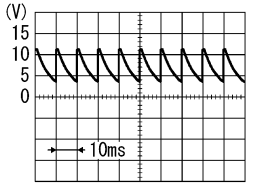
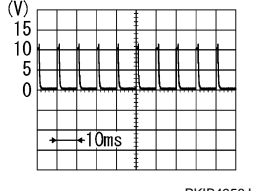
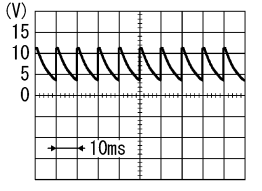
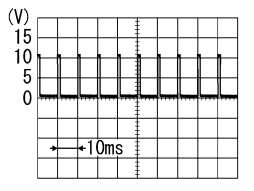
Terminal No. (Wire color)		Description		Condition	Value (Approx.)	
+	-	Signal name	Input/ Output			
32 (LG)	Ground	Combination switch OUTPUT 5	Output	Combination switch	All switch OFF (Wiper intermittent dial 4)	 <p style="text-align: right;">7.0 - 8.0 V</p>
					Front fog lamp switch ON (Wiper intermittent dial 4)	 <p style="text-align: right;">1.0 V</p>
					Rear wiper switch ON (Wiper intermittent dial 4)	
Any of the condition below with all switch OFF						
<ul style="list-style-type: none"> • Wiper intermittent dial 1 • Wiper intermittent dial 2 • Wiper intermittent dial 6 • Wiper intermittent dial 7 						
33 (Y/L)	Ground	Combination switch OUTPUT 4	Output	Combination switch	All switch OFF (Wiper intermittent dial 4)	 <p style="text-align: right;">7.0 - 8.0 V</p>
					Lighting switch 1ST (Wiper intermittent dial 4)	 <p style="text-align: right;">1.2 V</p>
					Lighting switch AUTO (Wiper intermittent dial 4)	
					Rear wiper switch INT (Wiper intermittent dial 4)	
Any of the condition below with all switch OFF						
<ul style="list-style-type: none"> • Wiper intermittent dial 1 • Wiper intermittent dial 5 • Wiper intermittent dial 6 						

BCM (BODY CONTROL MODULE)

< ECU DIAGNOSIS INFORMATION >

[REGULAR GRADE]

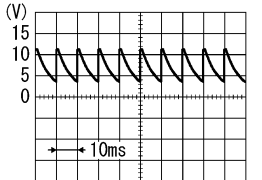
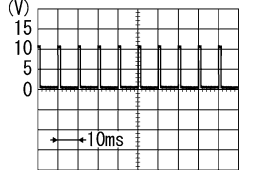
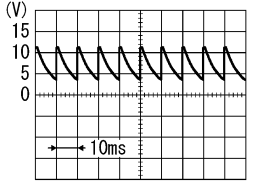
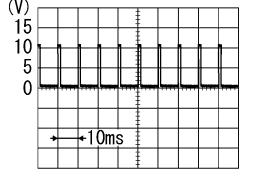
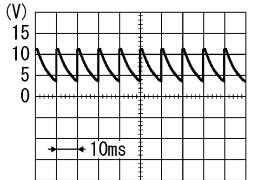
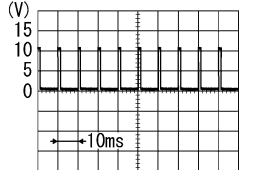
Terminal No. (Wire color)		Description		Condition	Value (Approx.)	
		Signal name	Input/ Output			
+	-					
34 (W)	Ground	Combination switch OUTPUT 3	Output	Combination switch	All switch OFF (Wiper intermittent dial 4)	 <p style="text-align: right; font-size: small;">PKIB4960J</p> <p style="text-align: center;">7.0 - 8.0 V</p>
					Lighting switch 2ND (Wiper intermittent dial 4)	 <p style="text-align: right; font-size: small;">PKIB4958J</p> <p style="text-align: center;">1.2 V</p>
					Lighting switch HI (Wiper intermittent dial 4)	
					Rear washer switch ON (Wiper intermittent dial 4)	
Any of the condition below with all switch OFF						
<ul style="list-style-type: none"> • Wiper intermittent dial 1 • Wiper intermittent dial 2 • Wiper intermittent dial 3 						
35 (R/L)	Ground	Combination switch OUTPUT 2	Output	Combination switch (Wiper intermit- tent dial 4)	All switch OFF	 <p style="text-align: right; font-size: small;">PKIB4960J</p> <p style="text-align: center;">7.0 - 8.0 V</p>
					Lighting switch 2ND	 <p style="text-align: right; font-size: small;">PKIB4958J</p> <p style="text-align: center;">1.2 V</p>
					Lighting switch PASS	
					Front wiper switch INT	
Front wiper switch HI						
36 (L/O)	Ground	Combination switch OUTPUT 1	Output	Combination switch (Wiper intermit- tent dial 4)	All switch OFF	 <p style="text-align: right; font-size: small;">PKIB4960J</p> <p style="text-align: center;">7.0 - 8.0 V</p>
					Turn signal switch RH	 <p style="text-align: right; font-size: small;">PKIB4958J</p> <p style="text-align: center;">1.2 V</p>
					Turn signal switch LH	
					Front wiper switch LO (Front wiper switch MIST)	
Front washer switch ON						

A
B
C
D
WT
F
G
H
I
J
K
L
M
N
O
P

BCM (BODY CONTROL MODULE)

< ECU DIAGNOSIS INFORMATION >

[REGULAR GRADE]

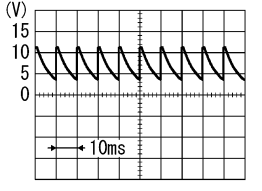
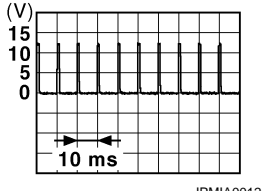
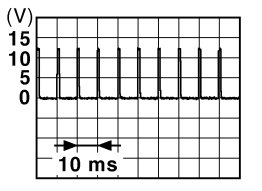
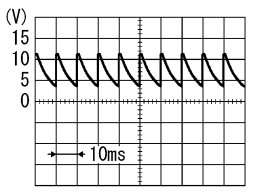
Terminal No. (Wire color)		Description		Condition		Value (Approx.)
		Signal name	Input/ Output			
+	-					
37 (G/O)	Ground	Selector lever P position switch	Input	Selector lever	P position	0 V
					Any position other than P	12 V
38 (O)	Ground	IGN feedback	Input	Ignition switch	OFF or ACC	0 V
					ON	Battery voltage
39 (L)	Ground	CAN-H	Input/ Output		—	—
40 (P)	Ground	CAN-L	Input/ Output		—	—
43 (W)	Ground	Back door switch	Input	Back door switch	OFF (When back door closed)	 <p style="text-align: center;">9.5 - 10.0 V</p>
					ON (When back door opened)	0 V
44 (LG)	Ground	Rear wiper stop position	Input	Ignition switch ON	Rear wiper stop position	12 V
					Any position other than rear wiper stop position	0 V
45 (GR)	Ground	Door lock and unlock switch LOCK	Input	Door lock and unlock switch	NEUTRAL position	 <p style="text-align: center;">1.0 - 1.5 V</p>
					LOCK position	0 V
46 (BR)	Ground	Door lock and unlock switch UNLOCK	Input	Door lock and unlock switch	NEUTRAL position	 <p style="text-align: center;">1.0 - 1.5 V</p>
					UNLOCK position	0 V
47 (BR/Y)	Ground	Driver door switch	Input	Driver door switch	OFF (When driver door closed)	 <p style="text-align: center;">7.0 - 8.0 V</p>
					ON (When driver door opened)	0 V

BCM (BODY CONTROL MODULE)

< ECU DIAGNOSIS INFORMATION >

[REGULAR GRADE]

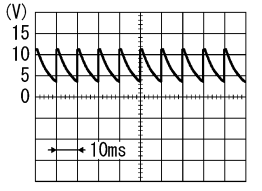
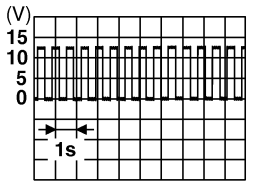
Terminal No. (Wire color)		Description		Condition		Value (Approx.)
+	-	Signal name	Input/ Output			
48 (W/G)	Ground	Rear LH door switch	Input	Rear LH door switch	OFF (When rear LH door closed)	 7.0 - 8.0 V
					ON (When rear door LH opened)	0 V
49 (Y)	Ground	Luggage room lamp	Output	Luggage room lamp switch DOOR position	Back door is closed (Back door lamp turns OFF)	12 V
					Back door is opened (Back door lamp turns ON)	0 V
54 (L/W)	Ground	Rear wiper	Output	Rear wiper	OFF (Stopped)	0 V
					ON (Activated)	12 V
55 (G)	Ground	Rear door UNLOCK	Output	Rear door	UNLOCK (Actuator is activated)	12 V
					Other than UNLOCK (Actuator is not activated)	0 V
56 (L)	Ground	Interior room lamp power supply	Output	Interior room lamp battery saver is activated. (Cuts the interior room lamp power supply)	0 V	
					Interior room lamp battery saver is not activated. (Outputs the interior room lamp power supply)	12 V
57 (Y)	Ground	Battery power supply	Input	Ignition switch OFF	Battery voltage	
59 (G)	Ground	Passenger door UNLOCK	Output	Passenger door	UNLOCK (Actuator is activated)	12 V
					Other than UNLOCK (Actuator is not activated)	0 V
60 (W/B)	Ground	Turn signal LH	Output	Ignition switch ON	Turn signal switch OFF	0 V
					Turn signal switch LH	 6.0 V

A
B
C
D
WT
F
G
H
I
J
K
L
M
N
O
P

BCM (BODY CONTROL MODULE)

< ECU DIAGNOSIS INFORMATION >

[REGULAR GRADE]

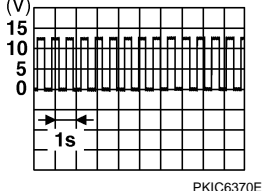
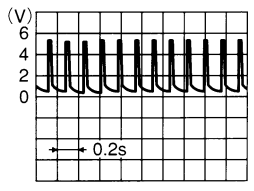
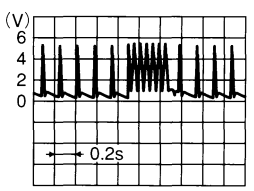
Terminal No. (Wire color)		Description		Condition	Value (Approx.)	
+	-	Signal name	Input/ Output			
61 (W/L)	Ground	Turn signal RH	Output	Ignition switch OFF	0 V	
				Ignition switch ON	Turn signal switch RH	 6.0 V
63 (BR)	Ground	Interior room lamp timer control	Output	Interior room lamp	OFF	12 V
				ON	0 V	
65 (V)	Ground	All doors LOCK	Output	All doors	LOCK (Actuator is activated)	12 V
				Other than LOCK (Actuator is not activated)	0 V	
66 (L/B)	Ground	Driver door UN-LOCK	Output	Driver door	UNLOCK (Actuator is activated)	12 V
				Other than UNLOCK (Actuator is not activated)	0 V	
67 (B)	Ground	Ground	Output	Ignition switch ON	0 V	
68 (L)	Ground	P/W power supply (IGN)	Output	Ignition switch ON	12 V	
69 (L/W)	Ground	P/W power supply (BAT)	Output	Ignition switch OFF	12 V	
70 (Y)	Ground	Battery power supply	Input	Ignition switch OFF	Battery voltage	
71 (R)	Ground	Tire pressure receiver communication	Input/ Output	Ignition switch ON	Standby state	 OCC3881D
				When receiving the signal from the transmitter	 OCC3880D	
72 (R/W)	Ground	Back door lock actuator relay control	Output	Back door	LOCK (Actuator is activated)	0 V
				Other than LOCK (Actuator is not activated)	Battery voltage	
75 (SB)	Ground	Driver door request switch	Input	Driver door request switch	ON (Pressed)	0 V
				OFF (Not pressed)	12 V	

BCM (BODY CONTROL MODULE)

< ECU DIAGNOSIS INFORMATION >

[REGULAR GRADE]

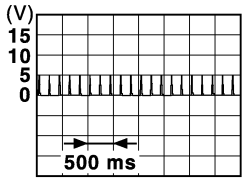
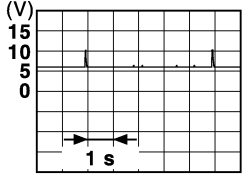
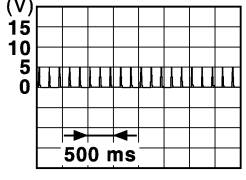
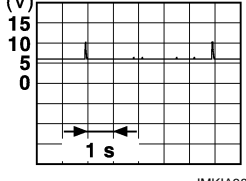
Terminal No. (Wire color)		Description		Condition		Value (Approx.)
+	-	Signal name	Input/ Output			
76 (G)	Ground	Passenger door re- quest switch	Input	Passenger door re- quest switch	ON (Pressed)	0 V
					OFF (Not pressed)	12 V
77 (W)	Ground	Back door request switch	Input	Back door re- quest switch	ON (Pressed)	0 V
					OFF (Not pressed)	12 V
78 (LG)	Ground	Driver door antenna (+)	Output	When the driver door request switch is operat- ed with ignition switch OFF	When Intelligent Key is not in the antenna detec- tion area	 <p style="text-align: right; font-size: small;">JMKIA3838GB</p>
					When Intelligent Key is in the antenna detection area	 <p style="text-align: right; font-size: small;">JMKIA3839GB</p>
79 (V)	Ground	Driver door antenna (-)	Output	When the driver door request switch is operat- ed with ignition switch OFF	When Intelligent Key is not in the antenna detec- tion area	 <p style="text-align: right; font-size: small;">JMKIA3838GB</p>
					When Intelligent Key is in the antenna detection area	 <p style="text-align: right; font-size: small;">JMKIA3839GB</p>

A
B
C
D
WT
F
G
H
I
J
K
L
M
N
O
P

BCM (BODY CONTROL MODULE)

< ECU DIAGNOSIS INFORMATION >

[REGULAR GRADE]

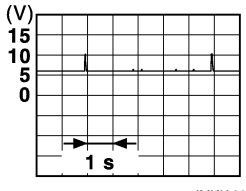
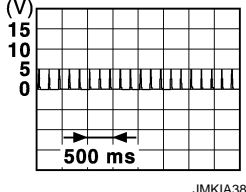
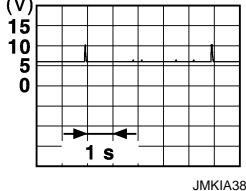
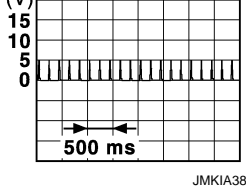
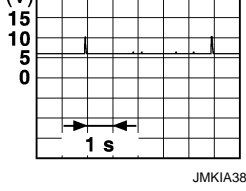
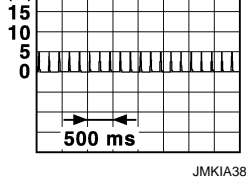
Terminal No. (Wire color)		Description		Condition	Value (Approx.)
+	-	Signal name	Input/ Output		
80 (BR/Y)	Ground	Passenger door antenna (+)	Output	When the passenger door request switch is operated with ignition switch OFF	When Intelligent Key is not in the antenna detection area
				When Intelligent Key is in the antenna detection area	
80 (BR/Y)	Ground	Passenger door antenna (+)	Output	When the passenger door request switch is operated with ignition switch OFF	When Intelligent Key is not in the antenna detection area
				When Intelligent Key is in the antenna detection area	
81 (L/Y)	Ground	Passenger door antenna (-)	Output	When the passenger door request switch is operated with ignition switch OFF	When Intelligent Key is not in the antenna detection area
				When Intelligent Key is in the antenna detection area	
81 (L/Y)	Ground	Passenger door antenna (-)	Output	When the passenger door request switch is operated with ignition switch OFF	When Intelligent Key is not in the antenna detection area
				When Intelligent Key is in the antenna detection area	
82 (W/B)	Ground	Back door antenna (+)	Output	When the back door request switch is operated with ignition switch OFF	When Intelligent Key is not in the antenna detection area
				When Intelligent Key is in the antenna detection area	
82 (W/B)	Ground	Back door antenna (+)	Output	When the back door request switch is operated with ignition switch OFF	When Intelligent Key is not in the antenna detection area
				When Intelligent Key is in the antenna detection area	

BCM (BODY CONTROL MODULE)

< ECU DIAGNOSIS INFORMATION >

[REGULAR GRADE]

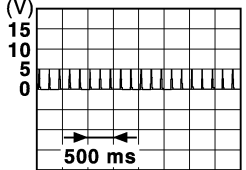
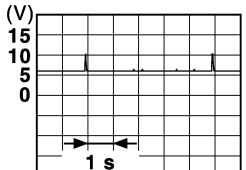
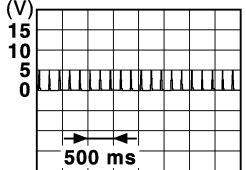
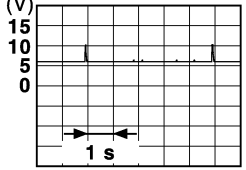
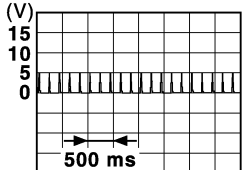
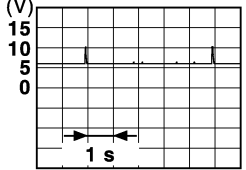
Terminal No. (Wire color)		Description		Condition	Value (Approx.)
		Signal name	Input/ Output		
+	-				
83 (B/W)	Ground	Back door antenna (-)	Output	When the back door request switch is operated with ignition switch OFF	 <p style="text-align: right; font-size: small;">JMkia3838GB</p>
				When Intelligent Key is in the antenna detection area	 <p style="text-align: right; font-size: small;">JMkia3839GB</p>
84 (Y/G)	Ground	Room antenna (+) (Instrument panel)	Output	Ignition switch OFF	 <p style="text-align: right; font-size: small;">JMkia3838GB</p>
				When Intelligent Key is in the antenna detection area	 <p style="text-align: right; font-size: small;">JMkia3839GB</p>
85 (Y/L)	Ground	Room antenna (-) (Instrument panel)	Output	Ignition switch OFF	 <p style="text-align: right; font-size: small;">JMkia3838GB</p>
				When Intelligent Key is in the antenna detection area	 <p style="text-align: right; font-size: small;">JMkia3839GB</p>

A
B
C
D
WT
F
G
H
I
J
K
L
M
N
O
P

BCM (BODY CONTROL MODULE)

< ECU DIAGNOSIS INFORMATION >

[REGULAR GRADE]

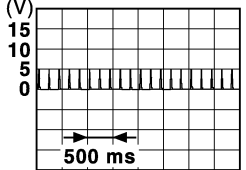
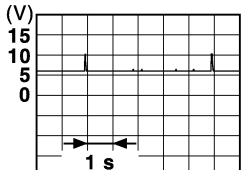
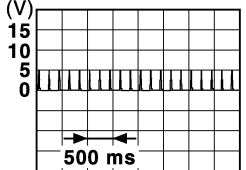
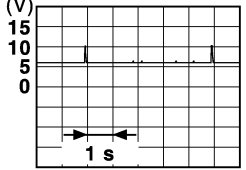
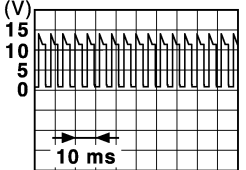
Terminal No. (Wire color)		Description		Condition	Value (Approx.)
+	-	Signal name	Input/ Output		
86 (P)	Ground	Luggage room antenna (+)	Output	Ignition switch OFF	 <p style="text-align: right; font-size: small;">JMkia3838GB</p>
				Ignition switch ON	 <p style="text-align: right; font-size: small;">JMkia3839GB</p>
87 (L)	Ground	Luggage room antenna (-)	Output	Ignition switch OFF	 <p style="text-align: right; font-size: small;">JMkia3838GB</p>
				Ignition switch ON	 <p style="text-align: right; font-size: small;">JMkia3839GB</p>
90 (W/L)	Ground	Push-button ignition switch illumination	Output	ON	12 V
				OFF	0 V
91 (Y)	Ground	ACC/ON indicator lamp	Output	Ignition switch OFF	Battery voltage
				Ignition switch ACC or ON	0.5 V
92 (BR/R)	Ground	Push-button ignition switch illumination ground	Output	Ignition switch OFF	0 V
				Ignition switch ON	<p style="text-align: center;">NOTE: When the illumination brightening/dimming level is in the neutral position</p>  <p style="text-align: right; font-size: small;">JPMIA1554GB</p> <p style="text-align: center;">6.0 - 7.0 V</p>

BCM (BODY CONTROL MODULE)

< ECU DIAGNOSIS INFORMATION >

[REGULAR GRADE]

Terminal No. (Wire color)		Description		Condition	Value (Approx.)	
		Signal name	Input/ Output			
+	-					
93 (GR/W)	Ground	Intelligent Key warn- ing buzzer	Output	Intelligent Key warning buzzer	Sounding	0 V
					Not sounding	12 V
94 (Y/R)	Ground	Steering lock unit communication	Input/ Output	Steering lock	LOCK status	12 V
					LOCK or UNLOCK	
					For 15 seconds after UN- LOCK	
					15 seconds or later after UNLOCK	0 V
95 (W/G)	Ground	Steering lock unit power supply	Output	Ignition switch	OFF or ACC	12 V
					ON	0 V
96 (BR/W)	Ground	ACC relay control	Output	Ignition switch	OFF	0 V
					ACC or ON	12 V
97 (L/R)	Ground	Starter relay control	Output	Ignition switch ON	When selector lever is in P or N position	Battery voltage
					When selector lever is not in P or N position	0 V
98 (BR)	Ground	Ignition relay (IPDM E/R) control	Output	Ignition switch	OFF or ACC	12 V
					ON	0 V
99 (W/R)	Ground	Ignition relay control	Output	Ignition switch	OFF or ACC	0 V
					ON	12 V
100 (L/O)	Ground	Push-button ignition switch (push switch)	Input	Push-button ig- nition switch (push switch)	Pressed	0 V
					Not pressed	12 V
102 (G)	Ground	Selector lever P/N position	Input	Selector lever	P or N position	Battery voltage
					Except P and N positions	0 V
104 (Y/R)	Ground	CVT shift selector (detention switch) power supply	Output	Ignition switch ON		12 V
105 (B/O)	Ground	Stop lamp switch 2	Input	Ignition switch OFF		Battery voltage
106 (Y/B)	Ground	Blower fan motor re- lay control	Output	Ignition switch	OFF or ACC	0 V
					ON	12 V
107 (L/W)	Ground	Steering lock condi- tion No. 1	Input	Steering lock	LOCK status	0 V
					UNLOCK status	12 V
108 (P/L)	Ground	Steering lock condi- tion No. 2	Input	Steering lock	LOCK status	12 V
					UNLOCK status	0 V
110 (BR/W)	Ground	Tire pressure receiv- er power supply	Output	Ignition switch	OFF or ACC	0 V
					ON	5 V

*: For Canada

A
B
C
D
F
G
H
I
J
K
L
M
N
O
P

WT

BCM (BODY CONTROL MODULE)

< ECU DIAGNOSIS INFORMATION >

[REGULAR GRADE]

Wiring Diagram - BCM -

INFOID:000000005072100

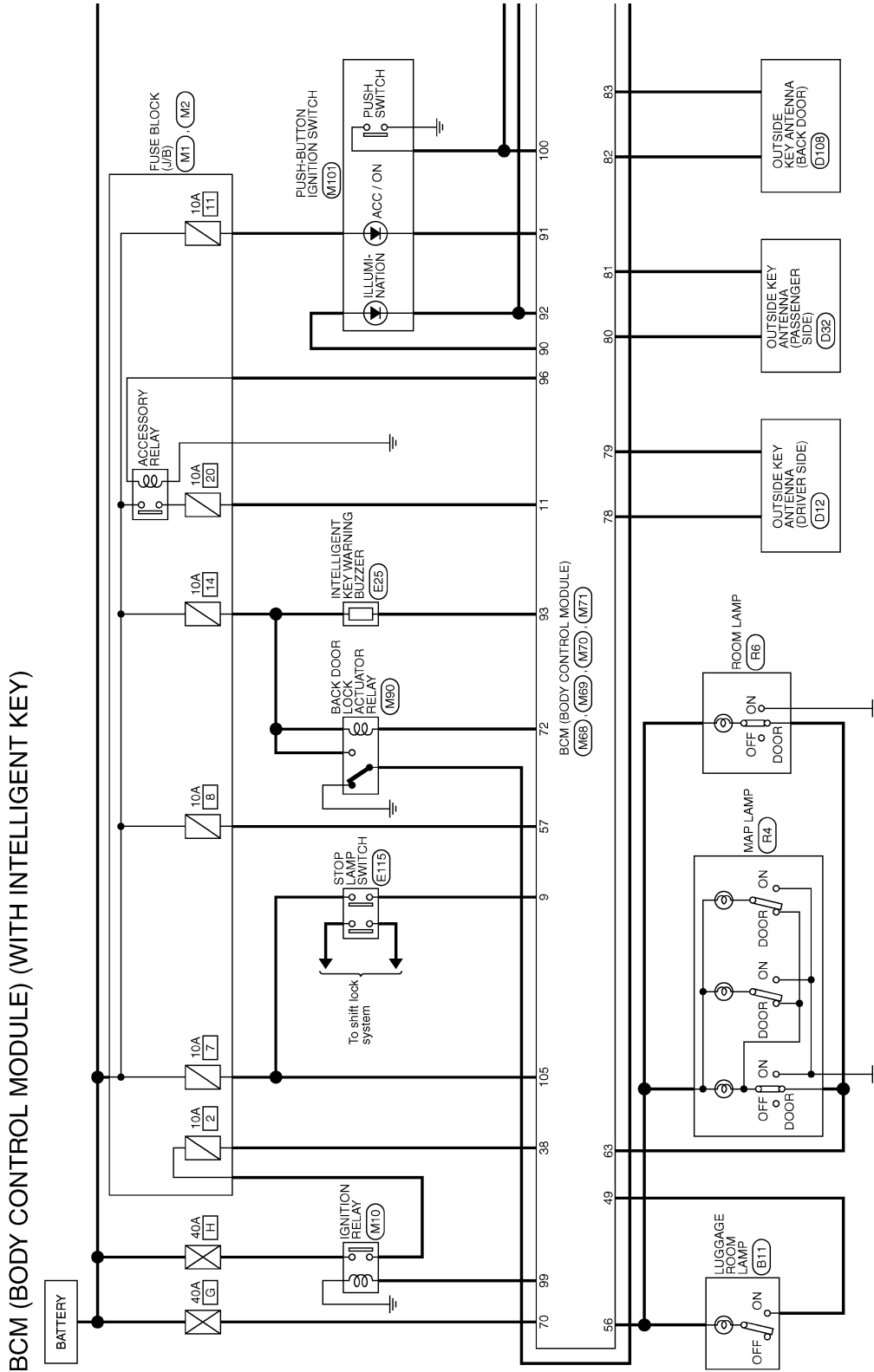

2009/02/27

JCMWM4068GB

BCM (BODY CONTROL MODULE)

< ECU DIAGNOSIS INFORMATION >

[REGULAR GRADE]

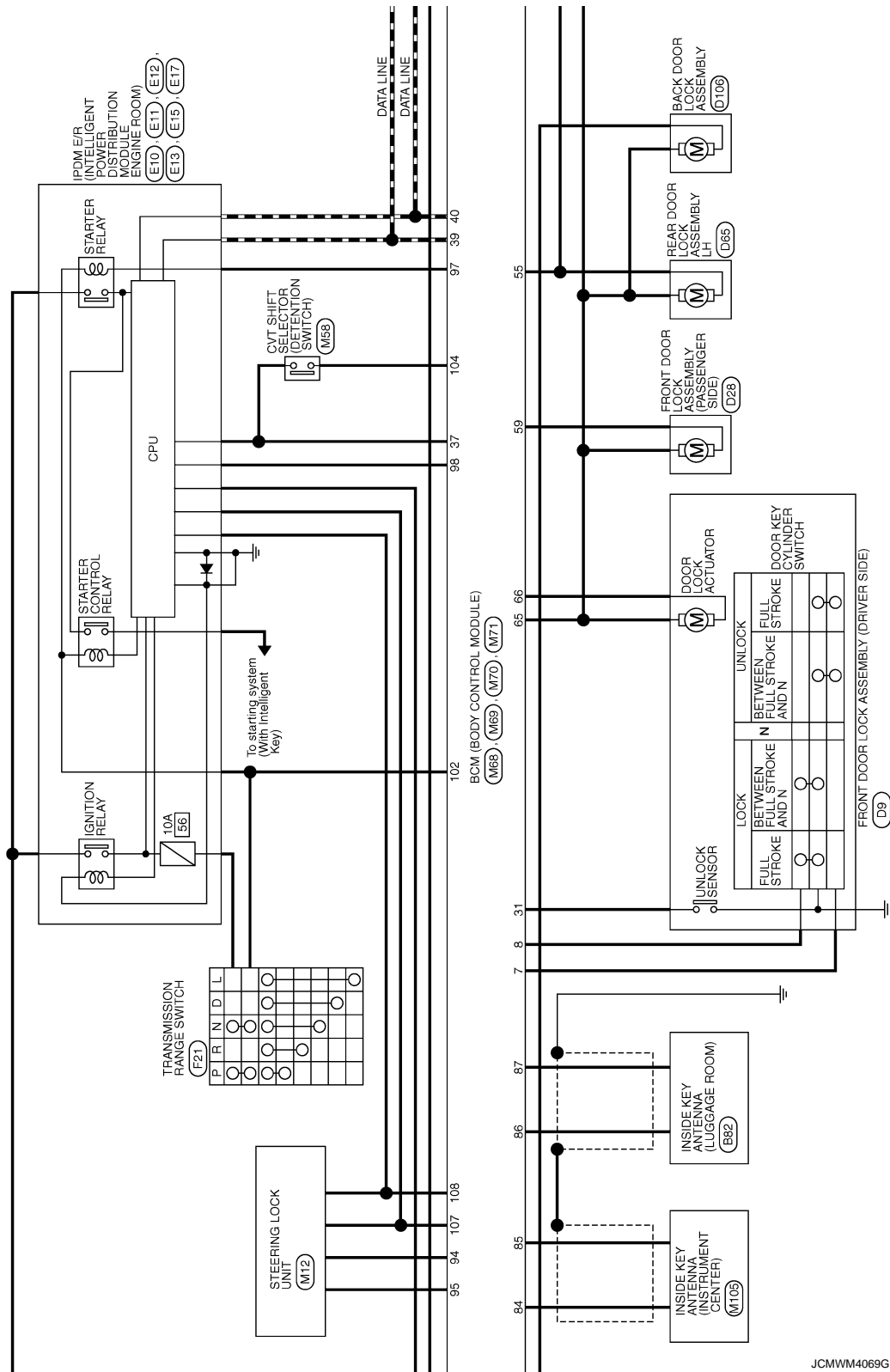

JCMWM4069GB

A
B
C
D
WT
F
G
H
I
J
K
L
M
N
O
P

BCM (BODY CONTROL MODULE)

< ECU DIAGNOSIS INFORMATION >

[REGULAR GRADE]

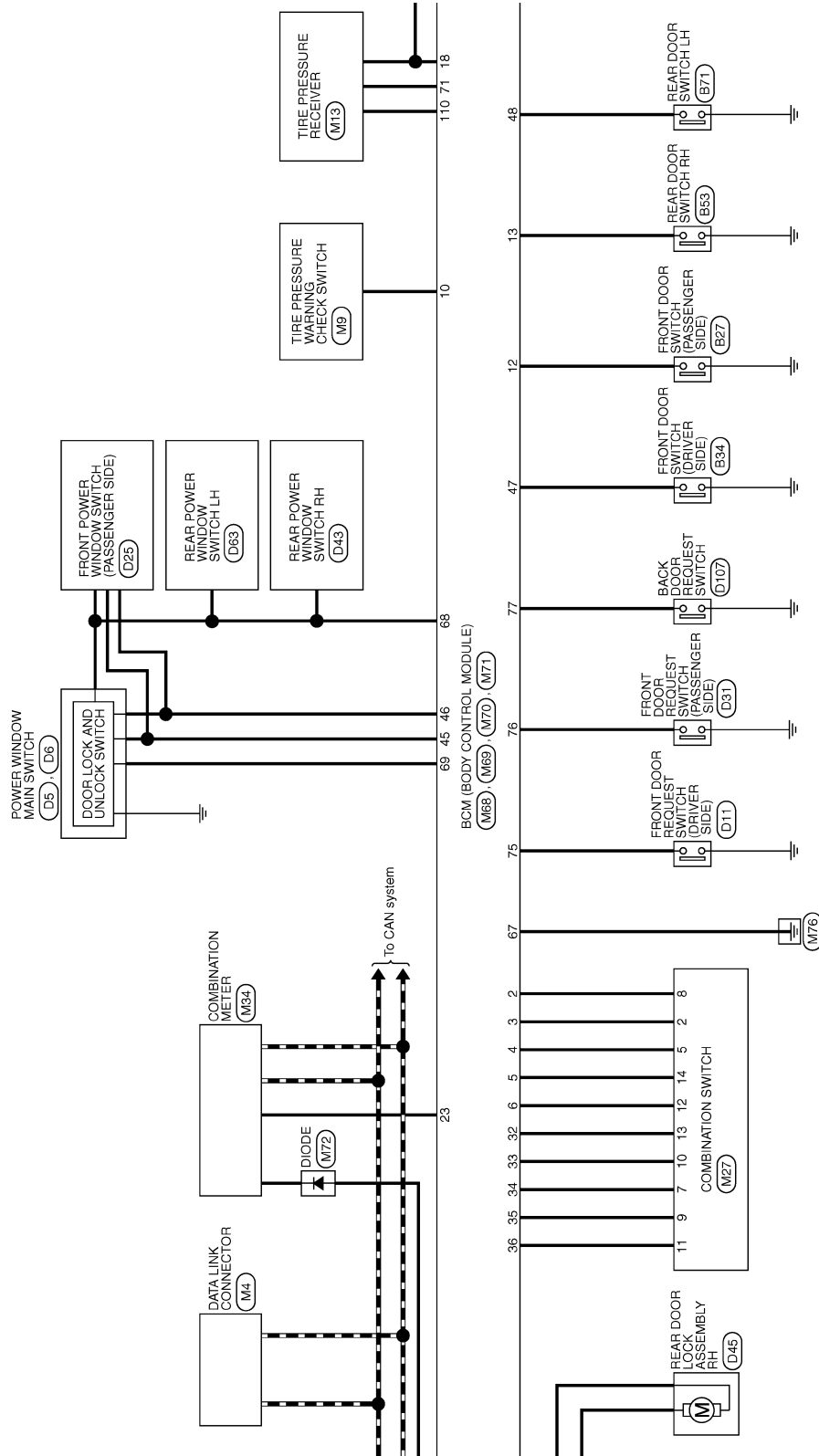

JCMWM4070GB

BCM (BODY CONTROL MODULE)

< ECU DIAGNOSIS INFORMATION >

[REGULAR GRADE]

 : For Canada

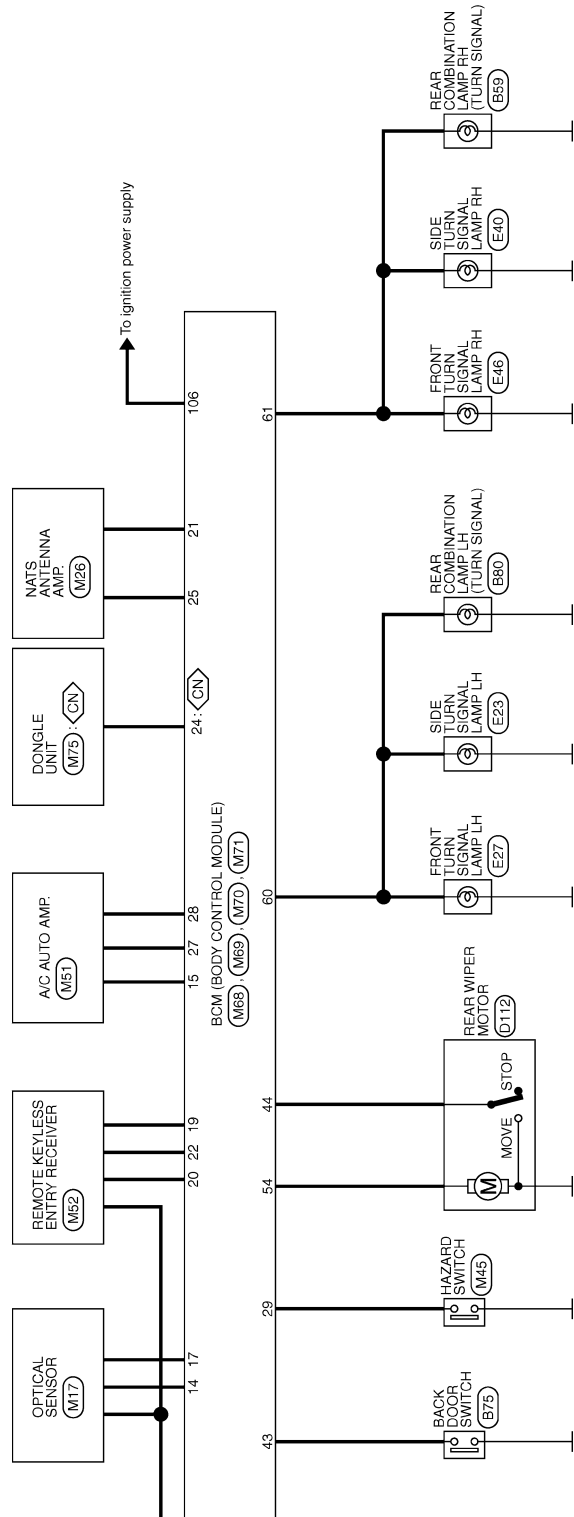

JCMWM4071GB

A
B
C
D
WT
F
G
H
I
J
K
L
M
N
O
P

BCM (BODY CONTROL MODULE)

< ECU DIAGNOSIS INFORMATION >

[REGULAR GRADE]

BCM (BODY CONTROL MODULE) (WITH INTELLIGENT KEY)

Connector No.	M27
Connector Name	COMBINATION SWITCH
Connector Type	TH16FW-NH



1	2	3	4	5	6
7	8	9	10	11	12
13	14				

Terminal No.	Color of Wire	Signal Name [Specification]
2	GR	INPUT 4
5	L/Y	INPUT 3
7	W	OUTPUT 3
8	BR/W	INPUT 5
9	R/L	OUTPUT 2
10	Y/L	OUTPUT 4
11	L/O	OUTPUT 1
12	L/R	INPUT 1
13	LG	OUTPUT 5
14	G	INPUT 2

Connector No.	M70
Connector Name	BCM (BODY CONTROL MODULE) (WITH INTELLIGENT KEY)
Connector Type	FEA09FB-FHA6-SA



56	57	58	59	60	61	63
65	66	67	68	69	70	

Terminal No.	Color of Wire	Signal Name [Specification]
56	L	INTERIOR ROOM LAMP POWER SUPPLY
57	Y	BAT (FUSE)
59	G	PASSENGER DOOR UNLOCK OUTPUT
60	W/B	TURN SIGNAL LH OUTPUT
61	W/L	TURN SIGNAL RH OUTPUT
63	BR	ROOM LAMP TIMER CONTROL
65	V	ALL DOOR LOCK OUTPUT
66	L/B	DRIVER DOOR UNLOCK OUTPUT
67	B	GND
68	L	POWER WINDOW POWER SUPPLY (GN)
69	L/W	POWER WINDOW POWER SUPPLY (BAT)

13	GR/L	REAR RH DOOR SW
14	L/B	OPTICAL SENSOR
15	W/L	REAR WINDOW DEFROGER SW
17	R/G	OPTICAL SENSOR POWER SUPPLY
18	V	RECEIVER SENSOR GND
19	BR	KEYLESS ENTRY RECEIVER POWER SUPPLY
20	G/Y	KEYLESS ENTRY RECEIVER COMM
21	P/L	NATS ANTENNA AMP
22	W/G	KEYLESS ENTRY RECEIVER RSSI
23	R/Y	SECURITY INDICATOR LAMP
24	GR/R	DOUBLE LINK
25	LG	NATS ANTENNA AMP
27	Y/G	A/C SW
28	G/W	BLOWER FAN SW
29	L/W	HAZARD SW
31	G/B	DR DOOR UNLOCK SENSOR
32	LG	COMBI SW OUTPUT 5
33	Y/L	COMBI SW OUTPUT 4
34	W	COMBI SW OUTPUT 3
35	R/L	COMBI SW OUTPUT 2
36	L/O	COMBI SW OUTPUT 1
37	L/O	SHIFT P
38	O	IGN F/B
39	L	CAN-H
40	P	CAN-L



13	14	15	17	18
19	20	21	22	23
24	25	27	28	29
31	32	33	34	35
36	37	38	39	40

Terminal No.	Color of Wire	Signal Name [Specification]
43	W	BACK DOOR SW
44	LG	REAR WIPER STOP POSITION
45	GR	CENTRAL DOOR LOCK SW
46	BR	CENTRAL DOOR UNLOCK SW
47	BR/Y	DRIVER DOOR SW
48	W/G	REAR LH DOOR SW
49	V	LUGGAGE ROOM LAMP OUTPUT
54	L/W	REAR WIPER OUTPUT
55	G	REAR DOOR UNLOCK OUTPUT

Connector No.	M71
Connector Name	BCM (BODY CONTROL MODULE) (WITH INTELLIGENT KEY)
Connector Type	THA0FW-NH



71	72	73	74	75	76	77	78	79
80	81	82	83	84	85	86	87	88
89	90	91	92	93	94	95	96	97

Terminal No.	Color of Wire	Signal Name [Specification]
71	R	TIRE PRESS RECEIVER COMM
72	R/W	BK DR LOCK ACT RELAY CONT
75	SB	DRIVER DOOR REQUEST SW
76	G	PASSENGER DOOR REQUEST SW
77	W	BACK DOOR REQUEST SW
78	LG	DRIVER DOOR ANT+
79	V	DRIVER DOOR ANT-
80	BR/Y	PASSENGER DOOR ANT+
81	L/Y	PASSENGER DOOR ANT-
82	W/B	BACK DOOR ANT+
83	B/W	BACK DOOR ANT-

Connector No.	M69
Connector Name	BCM (BODY CONTROL MODULE) (WITH INTELLIGENT KEY)
Connector Type	FEA09FW-FHA6-SA



43	44	45	46	47	48	49
54	55					

Terminal No.	Color of Wire	Signal Name [Specification]
43	W	BACK DOOR SW
44	LG	REAR WIPER STOP POSITION
45	GR	CENTRAL DOOR LOCK SW
46	BR	CENTRAL DOOR UNLOCK SW
47	BR/Y	DRIVER DOOR SW
48	W/G	REAR LH DOOR SW
49	V	LUGGAGE ROOM LAMP OUTPUT
54	L/W	REAR WIPER OUTPUT
55	G	REAR DOOR UNLOCK OUTPUT

Terminal No.	Color of Wire	Signal Name [Specification]
84	Y/G	ROOM ANT-
85	Y/L	ROOM ANT+
86	P	LUGGAGE ROOM ANT-
87	L	LUGGAGE ROOM ANT+
90	W/L	PUSH-BUTTON IGNITION SW ILL POWER
91	Y	ACC/ON IND
92	BR/R	PUSH-BUTTON IGNITION SW ILL GND
93	GR/W	H-KEY WARN BUZZER
94	Y/B	S/L UNIT COMM
95	W/G	S/L UNIT POWER SUPPLY
96	BR/W	ACC RELAY CONT
97	L/R	STARTER RELAY CONT
98	BR	IGN RELAY (IPDM E/F) CONT
99	W/R	IGN RELAY CONT
100	L/O	PUSH SW
102	G	SHIFT N/P
104	Y/R	CVT SHIFT SELECTOR POWER SUPPLY
105	B/O	STOP LAMP SW 2
106	Y/B	BLOWER FAN MOTOR RELAY CONT
107	L/W	S/L CONDITION 1
108	P/L	S/L CONDITION 2
110	BR/W	TIRE PRESS POWER SUPPLY

Fail-safe

FAIL-SAFE CONTROL BY DTC

BCM performs fail-safe control when any DTC are detected.

JCMWM4072GB

INFOID:000000005072101

BCM (BODY CONTROL MODULE)

< ECU DIAGNOSIS INFORMATION >

[REGULAR GRADE]

Display contents of CONSULT	Fail-safe	Cancellation	
B2013: ID DISCORD BCM-S/L	Inhibit engine cranking	When communication between BCM and steering lock unit are communicated normally.	A
B2014: CHAIN OF S/L-BCM	Inhibit engine cranking	When communication between BCM and steering lock unit are communicated normally.	B
B2192: ID DISCORD BCM-ECM	Inhibit engine cranking	Erase DTC	
B2193: CHAIN OF BCM-ECM	Inhibit engine cranking	Erase DTC	C
B2195: ANTI-SCANNING	Inhibit engine cranking	Ignition switch ON → OFF	
B2196: DONGLE NG	Inhibit engine cranking	Erase DTC	D
B2198: NATS ANTENNA AMP	Inhibit engine cranking	Erase DTC	
B2557: VEHICLE SPEED	Inhibit steering lock	When the following CAN signal status (vehicle speed signal) becomes consistent <ul style="list-style-type: none"> • Vehicle speed signal (ABS) • Vehicle speed signal (Meter) 	WT
B2601: SHIFT POSITION	Inhibit steering lock	500 ms after the following signal reception status becomes consistent <ul style="list-style-type: none"> • Selector lever P position switch signal • P range signal (CAN) 	F
B2602: SHIFT POSITION	Inhibit steering lock	5 seconds after the following BCM recognition conditions are fulfilled <ul style="list-style-type: none"> • Ignition switch is in the ON position • Selector lever P position switch signal: Except P position (battery voltage) • Vehicle speed: 4 km/h (2.5 MPH) or more 	G
B2603: SHIFT POSI STATUS	Inhibit steering lock	500 ms after any of the following BCM recognition conditions are fulfilled <ul style="list-style-type: none"> • Status 1 <ul style="list-style-type: none"> - Ignition switch is in the ON position - Selector lever P position switch signal: Except P position (12 V) - Selector lever P/N position signal: Except P and N positions (0 V) • Status 2 <ul style="list-style-type: none"> - Ignition switch is in the ON position - Selector lever P position switch signal: P position (0 V) - Selector lever P/N position signal: P or N positions (12 V) 	H
B2604: PNP/CLUTCH SW	Inhibit steering lock	500 ms after any of the following BCM recognition conditions are fulfilled <ul style="list-style-type: none"> • Status 1 <ul style="list-style-type: none"> - Ignition switch is in the ON position - Selector lever P/N position signal: P or N position (12 V) - Shift position signal (CAN): P or N position • Status 2 <ul style="list-style-type: none"> - Ignition switch is in the ON position - Selector lever P/N position signal: Except P and N positions (0 V) - Shift position signal (CAN): Except P and N position 	I
B2605: PNP/CLUTCH SW	Inhibit steering lock	500 ms after any of the following BCM recognition conditions are fulfilled <ul style="list-style-type: none"> • Status 1 <ul style="list-style-type: none"> - Power position: IGN - Selector lever P/N position signal: Except P and N positions (0 V) - Interlock/PNP switch signal (CAN): OFF • Status 2 <ul style="list-style-type: none"> - Ignition switch is in the ON position - Selector lever P/N position signal: P or N position (12 V) - Interlock/PNP switch signal (CAN): ON 	J
B2608: STARTER RELAY	Inhibit engine cranking	500 ms after the following signal communication status becomes consistent <ul style="list-style-type: none"> • Starter motor relay control signal • Starter relay status signal (CAN) 	K
B2609: S/L STATUS	<ul style="list-style-type: none"> • Inhibit engine cranking • Inhibit steering lock 	When the following steering lock conditions agree <ul style="list-style-type: none"> • BCM steering lock control status • Steering lock condition No. 1 signal status • Steering lock condition No. 2 signal status 	L
B260B: STEERING LOCK UNIT	Inhibit steering lock	Erase DTC	M

BCM (BODY CONTROL MODULE)

< ECU DIAGNOSIS INFORMATION >

[REGULAR GRADE]

Display contents of CONSULT	Fail-safe	Cancellation
B260D: STEERING LOCK UNIT	Inhibit steering lock	Erase DTC
B260F: ENG STATE SIG LOST	Inhibit engine cranking	When any of the following conditions are fulfilled <ul style="list-style-type: none">• Power position changes to ACC• Receives engine status signal (CAN)
B2612: S/L STATUS	<ul style="list-style-type: none">• Inhibit engine cranking• Inhibit steering lock	When any of the following conditions are fulfilled <ul style="list-style-type: none">• Steering lock unit status signal (CAN) is received normally• The BCM steering lock control status matches the steering lock status recognized by the steering lock unit status signal (CAN from IPDM E/R)
B2619: BCM	Inhibit engine cranking	1 second after the steering lock unit power supply output control inside BCM becomes normal
B26EF: STRG LCK RELAY OFF	Inhibit engine cranking	When the following conditions are fulfilled <ul style="list-style-type: none">• Steering lock relay signal (CAN): ON• Steering lock unit status signal (CAN): ON
B26F0: STRG LCK RELAY ON	Inhibit engine cranking	When the following conditions are fulfilled <ul style="list-style-type: none">• Steering lock relay signal (CAN): OFF• Steering lock unit status signal (CAN): OFF
B26F1: IGN RELAY OFF	Inhibit engine cranking	When the following conditions are fulfilled <ul style="list-style-type: none">• Ignition switch ON signal (CAN: Transmitted from BCM): ON• Ignition switch ON signal (CAN: Transmitted from IPDM E/R): ON
B26F2: IGN RELAY ON	Inhibit engine cranking	When the following conditions are fulfilled <ul style="list-style-type: none">• Ignition switch ON signal (CAN: Transmitted from BCM): OFF• Ignition switch ON signal (CAN: Transmitted from IPDM E/R): OFF
B26F3: START CONT RLY ON	Inhibit engine cranking	When the following conditions are fulfilled <ul style="list-style-type: none">• Starter control relay signal (CAN: Transmitted from BCM): OFF• Starter control relay signal (CAN: Transmitted from IPDM E/R): OFF
B26F4: START CONT RLY OFF	Inhibit engine cranking	When the following conditions are fulfilled <ul style="list-style-type: none">• Starter control relay signal (CAN: Transmitted from BCM): ON• Starter control relay signal (CAN: Transmitted from IPDM E/R): ON
B26F7: BCM	Inhibit engine cranking by Intelligent Key system	When room antenna and luggage room antenna functions normally
U0415: VEHICLE SPEED	Inhibit steering lock	When vehicle speed signal (Meter) (CAN) is received normally

HIGH FLASHER OPERATION

BCM detects the turn signal lamp circuit status by the current value.

BCM increases the turn signal lamp blinking speed if the bulb or harness open is detected with the turn signal lamp operating.

NOTE:

The blinking speed is normal while activating the hazard warning lamp.

REAR WIPER MOTOR PROTECTION

BCM detects the rear wiper stopping position according to the rear wiper stop position signal.

When the rear wiper stop position signal does not change for more than 5 seconds while driving the rear wiper, BCM stops power supply to protect the rear wiper motor.

Condition of cancellation

1. More than 1 minute is passed after the rear wiper stop.
2. Turn rear wiper switch OFF.
3. Operate the rear wiper switch or rear washer switch.

DTC Inspection Priority Chart

INFOID:000000005072102

If some DTCs are displayed at the same time, perform inspections one by one based on the following priority chart.

BCM (BODY CONTROL MODULE)

< ECU DIAGNOSIS INFORMATION >

[REGULAR GRADE]

Priority	DTC	
1	B2562: LOW VOLTAGE	A
2	<ul style="list-style-type: none"> • U1000: CAN COMM CIRCUIT • U1010: CONTROL UNIT (CAN) 	B
3	<ul style="list-style-type: none"> • B2192: ID DISCORD BCM-ECM • B2193: CHAIN OF BCM-ECM • B2195: ANTI-SCANNING • B2196: DONGLE NG • B2198: NATS ANTENNA AMP 	C
4	<ul style="list-style-type: none"> • B2013: ID DISCORD BCM-S/L • B2014: CHAIN OF S/L-BCM • B2553: IGNITION RELAY • B2555: STOP LAMP • B2556: PUSH-BTN IGN SW • B2557: VEHICLE SPEED • B2601: SHIFT POSITION • B2602: SHIFT POSITION • B2603: SHIFT POSI STATUS • B2604: PNP/CLUTCH SW • B2605: PNP/CLUTCH SW • B2608: STARTER RELAY • B2609: S/L STATUS • B260B: STEERING LOCK UNIT • B260C: STEERING LOCK UNIT • B260D: STEERING LOCK UNIT • B260F: ENG STATE SIG LOST • B2612: S/L STATUS • B2614: BCM • B2615: BCM • B2616: BCM • B2618: BCM • B2619: BCM • B261A: PUSH-BTN IGN SW • B26E9: LOCK MALFUNCTION • B26EF: STRG LCK RELAY OFF • B26F0: STRG LCK RELAY ON • B26F1: IGN RELAY OFF • B26F2: IGN RELAY ON • B26F3: START CONT RLY ON • B26F4: START CONT RLY OFF • B26F5: STRG LCK STS SW • B26F6: BCM • B26F7: BCM • B26F8: BCM • B26FC: KEY REGISTRATION • C1729: VHCL SPEED SIG ERR • U0415: VEHICLE SPEED 	D
		E
		F
		G
		H
		I
		J
		K
		L
		M
		N
		O
		P

WT

BCM (BODY CONTROL MODULE)

< ECU DIAGNOSIS INFORMATION >

[REGULAR GRADE]

Priority	DTC
5	<ul style="list-style-type: none"> • C1704: LOW PRESSURE FL • C1705: LOW PRESSURE FR • C1706: LOW PRESSURE RR • C1707: LOW PRESSURE RL • C1708: [NO DATA] FL • C1709: [NO DATA] FR • C1710: [NO DATA] RR • C1711: [NO DATA] RL • C1712: [CHECKSUM ERR] FL • C1713: [CHECKSUM ERR] FR • C1714: [CHECKSUM ERR] RR • C1715: [CHECKSUM ERR] RL • C1716: [PRESSDATA ERR] FL • C1717: [PRESSDATA ERR] FR • C1718: [PRESSDATA ERR] RR • C1719: [PRESSDATA ERR] RL • C1720: [CODE ERR] FL • C1721: [CODE ERR] FR • C1722: [CODE ERR] RR • C1723: [CODE ERR] RL • C1724: [BATT VOLT LOW] FL • C1725: [BATT VOLT LOW] FR • C1726: [BATT VOLT LOW] RR • C1727: [BATT VOLT LOW] RL • C1734: CONTROL UNIT
6	<ul style="list-style-type: none"> • B2621: INSIDE ANTENNA • B2622: INSIDE ANTENNA
7	<ul style="list-style-type: none"> • B2626: OUTSIDE ANTENNA • B2627: OUTSIDE ANTENNA • B2628: OUTSIDE ANTENNA

DTC Index

INFOID:000000005072103

NOTE:

The details of time display are as follows.

- CRNT: A malfunction is detected now.
- PAST: A malfunction was detected in the past.

IGN counter is displayed on Freeze Frame Data. For details of Freeze Frame Data, refer to [BCS-18, "COMMON ITEM : CONSULT-III Function \(BCM - COMMON ITEM\)"](#).

CONSULT display	Fail-safe	Freeze Frame Data •Vehicle Speed •Odo/Trip Meter •Vehicle Condition	Intelligent Key warning lamp ON	Tire pressure monitor warning lamp ON	Reference page
No DTC is detected. further testing may be required.	—	—	—	—	—
U1000: CAN COMM	—	—	—	—	BCS-39
U1010: CONTROL UNIT (CAN)	—	—	—	—	BCS-40
U0415: VEHICLE SPEED	×	—	×	—	BCS-41
B2013: ID DISCORD BCM-S/L	×	×	×	—	SEC-45
B2014: CHAIN OF S/L-BCM	×	×	×	—	SEC-46
B2192: ID DISCORD BCM-ECM	×	—	—	—	SEC-35
B2193: CHAIN OF BCM-ECM	×	—	—	—	SEC-37
B2195: ANTI-SCANNING	×	—	—	—	SEC-38
B2196: DONGLE NG	×	—	—	—	SEC-39

BCM (BODY CONTROL MODULE)

< ECU DIAGNOSIS INFORMATION >

[REGULAR GRADE]

CONSULT display	Fail-safe	Freeze Frame Data •Vehicle Speed •Odo/Trip Meter •Vehicle Condition	Intelligent Key warning lamp ON	Tire pressure monitor warning lamp ON	Reference page
B2198: NATS ANTENNA AMP	×	—	—	—	SEC-41
B2553: IGNITION RELAY	—	×	×	—	PCS-78
B2555: STOP LAMP	—	×	×	—	SEC-49
B2556: PUSH-BTN IGN SW	—	×	×	—	SEC-51
B2557: VEHICLE SPEED	×	×	×	—	SEC-53
B2562: LOW VOLTAGE	—	×	—	—	BCS-42
B2601: SHIFT POSITION	×	×	×	—	SEC-54
B2602: SHIFT POSITION	×	×	×	—	SEC-57
B2603: SHIFT POSI STATUS	×	×	×	—	SEC-60
B2604: PNP/CLUTCH SW	×	×	×	—	SEC-65
B2605: PNP/CLUTCH SW	×	×	×	—	SEC-68
B2608: STARTER RELAY	×	×	×	—	SEC-70
B2609: S/L STATUS	×	×	×	—	SEC-72
B260B: STEERING LOCK UNIT	×	×	×	—	SEC-75
B260C: STEERING LOCK UNIT	—	×	×	—	SEC-76
B260D: STEERING LOCK UNIT	×	×	×	—	SEC-77
B260F: ENG STATE SIG LOST	×	×	×	—	SEC-78
B2612: S/L STATUS	×	×	×	—	SEC-79
B2614: BCM	—	×	×	—	PCS-80
B2615: BCM	—	×	×	—	PCS-83
B2616: BCM	—	×	×	—	PCS-86
B2618: BCM	—	×	×	—	PCS-89
B2619: BCM	×	×	×	—	SEC-82
B261A: PUSH-BTN IGN SW	—	×	×	—	PCS-90
B2621: INSIDE ANTENNA	—	×	—	—	DLK-44
B2622: INSIDE ANTENNA	—	×	—	—	DLK-46
B2626: OUTSIDE ANTENNA	—	×	—	—	DLK-48
B2627: OUTSIDE ANTENNA	—	×	—	—	DLK-50
B2628: OUTSIDE ANTENNA	—	×	—	—	DLK-52
B26E9: LOCK MALFUNCTION	—	×	× (Turn ON for 15 seconds)	—	SEC-83
B26EF: STRG LCK RELAY OFF	×	×	×	—	SEC-84
B26F0: STRG LCK RELAY ON	×	×	×	—	SEC-86
B26F1: IGN RELAY OFF	×	×	×	—	PCS-92
B26F2: IGN RELAY ON	×	×	×	—	PCS-95
B26F3: START CONT RLY ON	×	×	×	—	SEC-87
B26F4: START CONT RLY OFF	×	×	×	—	SEC-88
B26F5: STRG LCK STS SW	—	×	×	—	SEC-90
B26F6: BCM	—	×	×	—	PCS-98
B26F7: BCM	×	×	×	—	SEC-93
B26F8: BCM	—	×	×	—	SEC-94

A
B
C
D
WT
F
G
H
I
J
K
L
M
N
O
P

BCM (BODY CONTROL MODULE)

< ECU DIAGNOSIS INFORMATION >

[REGULAR GRADE]

CONSULT display	Fail-safe	Freeze Frame Data •Vehicle Speed •Odo/Trip Meter •Vehicle Condition	Intelligent Key warning lamp ON	Tire pressure monitor warning lamp ON	Reference page
B26FC: KEY REGISTRATION	—	×	×	—	SEC-95
C1704: LOW PRESSURE FL	—	—	—	×	WT-16
C1705: LOW PRESSURE FR	—	—	—	×	
C1706: LOW PRESSURE RR	—	—	—	×	
C1707: LOW PRESSURE RL	—	—	—	×	
C1708: [NO DATA] FL	—	—	—	×	WT-18
C1709: [NO DATA] FR	—	—	—	×	
C1710: [NO DATA] RR	—	—	—	×	
C1711: [NO DATA] RL	—	—	—	×	
C1712: [CHECKSUM ERR] FL	—	—	—	×	WT-21
C1713: [CHECKSUM ERR] FR	—	—	—	×	
C1714: [CHECKSUM ERR] RR	—	—	—	×	
C1715: [CHECKSUM ERR] RL	—	—	—	×	
C1716: [PRESSDATA ERR] FL	—	—	—	×	WT-24
C1717: [PRESSDATA ERR] FR	—	—	—	×	
C1718: [PRESSDATA ERR] RR	—	—	—	×	
C1719: [PRESSDATA ERR] RL	—	—	—	×	
C1720: [CODE ERR] FL	—	—	—	×	WT-26
C1721: [CODE ERR] FR	—	—	—	×	
C1722: [CODE ERR] RR	—	—	—	×	
C1723: [CODE ERR] RL	—	—	—	×	
C1724: [BATT VOLT LOW] FL	—	—	—	×	WT-29
C1725: [BATT VOLT LOW] FR	—	—	—	×	
C1726: [BATT VOLT LOW] RR	—	—	—	×	
C1727: [BATT VOLT LOW] RL	—	—	—	×	
C1729: VHCL SPEED SIG ERR	—	—	—	×	WT-32
C1734: CONTROL UNIT	—	—	—	×	WT-34

SYMPTOM DIAGNOSIS

TPMS

Symptom Table

INFOID:000000005038124

LOW TIRE PRESSURE WARNING LAMP SYMPTOM CHART

A

B

C

D

WT

F

G

H

I

J

K

L

M

N















O

P

TPMS

< SYMPTOM DIAGNOSIS >

[REGULAR GRADE]

Diagnosis items	Symptom (Ignition switch ON)	Low tire pressure warning lamp	Cause	Action
Low tire pressure warning lamp	The low tire pressure warning lamp illuminates for 1 second, then turns OFF.	  ON 1 sec > stays OFF <small>SEIA0592E</small>	Wake-up operation for all transmitters at wheels is completed.	No system malfunctions
	The low tire pressure warning lamp repeats blinking ON for 2 seconds and OFF for 0.2 seconds.	 Blinks:  ON 2 sec > OFF 0.2 sec <small>SEIA0593E</small>	Wake-up operation for all transmitters at wheels is not completed.	Perform the wake-up operation for all transmitters at wheels. Refer to WT-6, "TRANSMITTER WAKE UP OPERATION : Special Repair Requirement" .
	The low tire pressure warning lamp blinks once.	 Blinks 1 time ON 0.3 sec > OFF 1.3 sec <small>SEIA0594E</small>	The front left transmitter is not activated.	Perform the wake-up operation for the transmitter at front left wheel. Refer to WT-6, "TRANSMITTER WAKE UP OPERATION : Special Repair Requirement" .
	The low tire pressure warning lamp repeats blinking twice.	  Blinks 2 times ON 0.3 sec > OFF 0.3 sec <small>SEIA0595E</small>	The front right transmitter is not activated.	Perform the wake-up operation for the transmitter at front right wheel. Refer to WT-6, "TRANSMITTER WAKE UP OPERATION : Special Repair Requirement" .
	The low tire pressure warning lamp repeats blinking for 3 times.	   Blinks 3 times ON 0.3 sec > OFF 0.3 sec <small>SEIA0596E</small>	The rear right transmitter is not activated.	Perform the wake-up operation for the transmitter at rear right wheel. Refer to WT-6, "TRANSMITTER WAKE UP OPERATION : Special Repair Requirement" .
	The low tire pressure warning lamp repeats blinking for 4 times.	    Blinks 4 times ON 0.3 sec > OFF 0.3 sec <small>SEIA0597E</small>	The rear left transmitter is not activated.	Perform the wake-up operation for the transmitter at rear left wheel. Refer to WT-6, "TRANSMITTER WAKE UP OPERATION : Special Repair Requirement" .
	The low tire pressure warning lamp turns ON and stays illuminated.	 Comes ON and stays ON <small>SEIA0598E</small>	Low tire pressure	Check with CONSULT-III the tire pressure values. Refer to WT-11, "COMMON ITEM : CONSULT-III Function (BCM - COMMON ITEM)" .

TPMS

< SYMPTOM DIAGNOSIS >

[REGULAR GRADE]

Diagnosis items	Symptom (Ignition switch ON)	Low tire pressure warning lamp	Cause	Action
Low tire pressure warning lamp	The low tire pressure warning lamp repeats blinking at 0.5-second intervals for 1 minute, and then stays illuminated.	 <p style="text-align: center;">Blinks 1 min</p> <p style="text-align: center;">ON 0.5 sec > OFF 0.5 sec and stays ON</p> <p style="text-align: center;"><small>SEIA0788E</small></p>	The combination meter fuse is open or removed (or pulled out).	Check and install the combination meter fuse. If necessary, replace the fuse.
			The low tire pressure warning control unit harness connector is removed.	Check the connection conditions of the low tire pressure warning control unit harness connector, and repair if necessary.
			Tire Pressure Monitoring System (TPMS) malfunction.	<ul style="list-style-type: none"> • Perform CONSULT-III self-diagnosis. Refer to WT-11, "COMMON ITEM : CONSULT-III Function (BCM - COMMON ITEM)". • If necessary, perform transmitter ID registration. Refer to WT-6, "ID REGISTRATION PROCEDURE : Special Repair Requirement".
Turn signal lamp	The turn signal lamps do not blink twice when the transmitter is activated. Or the buzzer does not sound.	—	<ol style="list-style-type: none"> 1. The transmitter activation tool (J-45295) does not activate. 2. The ignition switch is OFF when the transmitter wake-up operation is performed. 3. The transmitter activation tool (J-45295) is not used in the correct position. 4. The transmitter is already waked up. 	<ol style="list-style-type: none"> 1. Replace the battery in the transmitter activation tool (J-45295). 2. Turn the ignition switch ON when performing the transmitter wake-up operation. 3. Operate the transmitter activation tool (J-45295) in the correct position when performing the wake-up operation. 4. No procedure.

NOTE:

If transmitter wake-up operation is not completed for two or more transmitters, the applicable low tire pressure warning lamp blinking patterns are displayed continuously.

(Example: Blinks once/OFF/blinks 3 times = Wake-up operation is not completed at the front left wheel and rear right wheel transmitters.)

A
B
C
D
WT
F
G
H
I
J
K
L
M
N
O
P

LOW TIRE PRESSURE WARNING LAMP DOES NOT BLINKS

< SYMPTOM DIAGNOSIS >

[REGULAR GRADE]

LOW TIRE PRESSURE WARNING LAMP DOES NOT BLINKS

Description

INFOID:000000005038125

DESCRIPTION

The low tire pressure warning lamp illuminates for approximately 1 second and then turns OFF when the ignition switch is turned ON. This is to check that no abnormal condition is present in the tire pressure monitoring system.

The lamp bulb may be burnt out or the tire pressure monitoring system may be malfunctioning if the low tire pressure warning lamp does not illuminate when the ignition switch is turned ON.

Diagnosis Procedure

INFOID:000000005038126

1. CHECK LOW TIRE PRESSURE WARNING LAMP

Perform trouble diagnosis of the low tire pressure warning lamp. Refer to [WT-40, "Diagnosis Procedure"](#).

Is the inspection result normal?

- YES >> Check pin terminal and connection of each connector for damage and loose connection.
- NO >> Repair or replace damaged parts.

LOW TIRE PRESSURE WARNING LAMP DOES NOT TURN OFF

< SYMPTOM DIAGNOSIS >

[REGULAR GRADE]

LOW TIRE PRESSURE WARNING LAMP DOES NOT TURN OFF

Description

INFOID:000000005038127

The low tire pressure warning lamp does not turn OFF after several seconds is passed after engine starts.

Diagnosis Procedure

INFOID:000000005038128

1. CHECK BCM

Ⓜ With CONSULT-III
Perform BCM (AIR PRESSURE MONITOR) self-diagnosis.

Is any DTC detected?

- YES >> Check the DTC. Refer to [WT-74, "DTC Index"](#).
- NO >> GO TO 2.

2. CHECK BCM POWER SUPPLY AND GROUND

1. Turn the ignition switch OFF.
2. Disconnect the BCM harness connector.
3. Turn the ignition switch ON.
CAUTION:
Never start the engine.
4. Check the voltage between the BCM harness connector and the ground.

BCM		—	Voltage
Connector	Terminal		
M70	57	Ground	Battery voltage
	70		

Is the inspection result normal?

- YES >> Replace BCM. Refer to [BCS-82, "Exploded View"](#).
- NO >> Repair or replace damaged parts.

A
B
C
D
E
F
G
H
I
J
K
L
M
N
O
P

WT

LOW TIRE PRESSURE WARNING LAMP BLINKS

< SYMPTOM DIAGNOSIS >

[REGULAR GRADE]

LOW TIRE PRESSURE WARNING LAMP BLINKS

Description

INFOID:000000005038129

DESCRIPTION

The low tire pressure warning lamp illuminates or blinks.

However, a check is necessary because the symptom may not be caused by a system malfunction. For example, the transmitter may not be initialized.

NOTE:

If low tire pressure warning lamp blinks as shown in the figure, the system is normal.

Blink Mode A

- This mode shows transmitter status is in OFF- mode. Perform transmitter wake up operation. Refer to [WT-6, "TRANSMITTER WAKE UP OPERATION : Special Repair Requirement"](#).

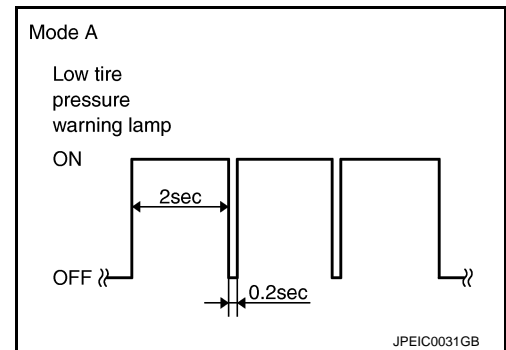

Diagnosis Procedure

INFOID:000000005038130

1. CHECK TIRE PRESSURE WARNING CHECK SWITCH POWER SUPPLY

- Turn the ignition switch ON.

CAUTION:

Never start the engine.

- Check voltage between tire pressure warning check switch connector and ground.

Tire pressure warning check switch		—	Condition	Voltage (Approx.)
Connector	Terminal			
M9	1	Ground	Ignition switch OFF	<p>(V) 15 10 5 0 10 ms 1.0 - 1.5 V JPMIA0012GB</p>

Is the inspection result normal?

YES >> GO TO 2.

NO >> Riper or replace error-detected damaged parts.

2. CHECK TIRE PRESSURE WARNING CHECK SWITCH CIRCUIT

- Turn the ignition switch OFF.
- Disconnect BCM harness connector.
- Check the continuity between BCM harness connector and tire pressure warning check switch connector.

BCM		Tire pressure warning check switch		Continuity
Connector	Terminal	Connector	Terminal	
M68	10	M9	1	Existed

- Check the continuity between BCM harness connector and ground.

LOW TIRE PRESSURE WARNING LAMP BLINKS

< SYMPTOM DIAGNOSIS >

[REGULAR GRADE]

BCM		—	Continuity
Connector	Terminal		
M68	10	Ground	Not existed

Is the inspection result normal?

YES >> GO TO 3.

NO >> Riper or replace error-detected damaged parts.

3. CHECK BCM

Check the BCM input/output signal. Refer to [WT-45. "Reference Value"](#).

Is the inspection result normal?

YES >> Check the tire pressure warning check switch. Refer to [WT-38. "Diagnosis Procedure"](#).

NO >> Repair or replace the BCM.

A
B
C
D
F
G
H
I
J
K
L
M
N
O
P

WT

TURN SIGNAL LAMP BLINKS

< SYMPTOM DIAGNOSIS >

[REGULAR GRADE]

TURN SIGNAL LAMP BLINKS

Description

INFOID:000000005038131

DESCRIPTION

The turn signal lamp blinks when the ignition switch is turned ON.
The BCM connector or circuit may have a malfunction.

Diagnosis Procedure

INFOID:000000005038132

1. CHECK TIRE PRESSURE WARNING CHECK SWITCH POWER SUPPLY CIRCUIT

1. Turn the ignition switch ON.

CAUTION:

Never start the engine.

2. Check voltage between tire pressure warning check switch connector and ground.

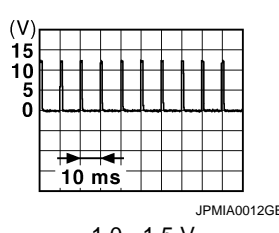
Tire pressure warning check switch		—	Condition	Voltage (Approx.)
Connector	Terminal			
M9	1	Ground	Ignition switch OFF	

Is the inspection result normal?

YES >> GO TO 2.

NO >> Repair or replace damaged parts.

2. CHECK TIRE PRESSURE WARNING CHECK SWITCH CIRCUIT

1. Turn the ignition switch OFF.
2. Disconnect BCM harness connector.
3. Check the continuity between BCM harness connector and tire pressure warning check switch connector.

BCM		Tire pressure warning check switch		Continuity
Connector	Terminal	Connector	Terminal	
M68	10	M9	1	Existed

4. Check the continuity between BCM harness connector and ground.

BCM		—	Continuity
Connector	Terminal		
M68	10	Ground	Not existed

Is the inspection result normal?

YES >> Check the turn signal lamp operation. Refer to [BCS-35, "SIGNAL BUFFER : CONSULT-III Function \(BCM - SIGNAL BUFFER\)"](#).

NO >> Repair or replace damaged parts.

ID REGISTRATION CANNOT BE COMPLETED

< SYMPTOM DIAGNOSIS >

[REGULAR GRADE]

ID REGISTRATION CANNOT BE COMPLETED

Description

INFOID:000000005038133

DESCRIPTION

The ID of the transmitter installed in each wheel cannot be registered in the tire pressure monitoring system. Inspect the transmitter or the tire pressure monitoring system circuit.

Diagnosis Procedure

INFOID:000000005038134

1. CHECK TRANSMITTER ID REGISTRATION

1. Perform transmitter ID registration for all wheels. Refer to [WT-6, "ID REGISTRATION PROCEDURE : Special Repair Requirement"](#).
2. Drive for 3 minutes at a speed of 40 km/h (25 MPH) or more, then drive normally for 10 minutes.
3. On "DATA MONITOR", select "AIR PRESS FL", "AIR PRESS FR", "AIR PRESS RR" and "AIR PRESS RL", and check that the tire pressures match the standard value.

Monitor item	Measuring condition	Displayed value
AIR PRESS FL	Drive for 3 minutes at a speed of 40 km/h (25 MPH) or more, then drive normally for 10 minutes.	Internal pressure of tires
AIR PRESS FR		
AIR PRESS RR		
AIR PRESS RL		

CAUTION:

Stop the vehicle and within 5 minutes, use CONSULT-III "DATA MONITOR" to display the tire pressure for all wheels.

Is the inspection result normal?

- YES >> INSPECTION END
NO >> GO TO 2.

2. CHECK TRANSMITTERS

1. Perform trouble diagnosis for the transmitter. Refer to [WT-26, "Diagnosis Procedure"](#).
2. Perform transmitter ID registration for all wheels. Refer to [WT-6, "ID REGISTRATION PROCEDURE : Special Repair Requirement"](#).
3. Check that transmitter ID registration is completed for all wheels.

Is transmitter ID registration for all wheels been completed?

- YES >> INSPECTION END
NO >> Replace the transmitter. Refer to [WT-94, "Exploded View"](#).

NORMAL OPERATING CONDITION

Description

INFOID:000000005038135

LOW TIRE PRESSURE WARNING LAMP BLINKS

If the low tire pressure warning lamp blinks as shown in the figure after the ignition switch is turned ON, the transmitter is not waked up. Perform the transmitter wake-up operation. Refer to [WT-6, "TRANSMITTER WAKE UP OPERATION : Special Repair Requirement"](#).

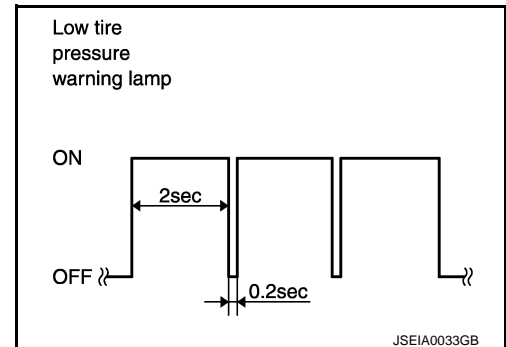

NOISE, VIBRATION AND HARSHNESS (NVH) TROUBLESHOOTING

< SYMPTOM DIAGNOSIS >

[REGULAR GRADE]

NOISE, VIBRATION AND HARSHNESS (NVH) TROUBLESHOOTING

NVH Troubleshooting Chart

INFOID:000000005038136

Use chart below to find the cause of the symptom. If necessary, repair or replace these parts.

Reference page			FSU-8, FSU-10	WT-90, "Inspection"	WT-91, "Adjustment"	WT-97, "Tire Air Pressure"	WT-91, "Adjustment"	—	—	WT-97, "Tire Air Pressure"	NVH in FAX and FSU sections.	NVH in RAX and RSU sections.	Refer to TIRES in this chart.	Refer to ROAD WHEEL in this chart.	NVH in RAX section.	NVH in BR section.	NVH in ST section.	
Possible cause and SUSPECTED PARTS			Improper installation, looseness	Out-of-round	unbalance	Incorrect tire pressure	Uneven tire wear	Deformation or damage	Non-uniformity	Incorrect tire size	FRONT AXLE AND FRONT SUSPENSION	REAR AXLE AND REAR SUSPENSION	TIRES	ROAD WHEELS	DRIVE SHAFT	BRAKE	STEERING	
Symptom	TIRES	Noise	x	x	x	x	x	x	x	x	x	x	x	x	x	x	x	
		Shake	x	x	x	x	x	x	x	x	x	x	x	x	x	x	x	x
		Vibration				x					x	x	x		x			x
		Shimmy	x	x	x	x	x	x	x	x	x	x	x	x		x	x	x
		Judder	x	x	x	x	x	x	x		x	x	x	x			x	x
		Poor quality ride or handling	x	x	x	x	x	x	x		x	x		x	x			
	ROAD WHEEL	Noise	x	x	x			x				x	x	x		x	x	x
		Shake	x	x	x			x				x	x	x		x	x	x
		Shimmy, Judder	x	x	x			x				x	x	x		x	x	x
		Poor quality ride or handling	x	x	x				x			x	x	x				

x: Applicable

A
B
C
D
E
F
G
H
I
J
K
L
M
N
O
P

WT

PRECAUTION

PRECAUTIONS

Precaution for Supplemental Restraint System (SRS) "AIR BAG" and "SEAT BELT PRE-TENSIONER"

INFOID:000000005153309

The Supplemental Restraint System such as "AIR BAG" and "SEAT BELT PRE-TENSIONER", used along with a front seat belt, helps to reduce the risk or severity of injury to the driver and front passenger for certain types of collision. This system includes seat belt switch inputs and dual stage front air bag modules. The SRS system uses the seat belt switches to determine the front air bag deployment, and may only deploy one front air bag, depending on the severity of a collision and whether the front occupants are belted or unbelted. Information necessary to service the system safely is included in the "SRS AIR BAG" and "SEAT BELT" of this Service Manual.

WARNING:

- To avoid rendering the SRS inoperative, which could increase the risk of personal injury or death in the event of a collision which would result in air bag inflation, all maintenance must be performed by an authorized NISSAN/INFINITI dealer.
- Improper maintenance, including incorrect removal and installation of the SRS, can lead to personal injury caused by unintentional activation of the system. For removal of Spiral Cable and Air Bag Module, see the "SRS AIR BAG".
- Do not use electrical test equipment on any circuit related to the SRS unless instructed to in this Service Manual. SRS wiring harnesses can be identified by yellow and/or orange harnesses or harness connectors.

PRECAUTIONS WHEN USING POWER TOOLS (AIR OR ELECTRIC) AND HAMMERS

WARNING:

- When working near the Air Bag Diagnosis Sensor Unit or other Air Bag System sensors with the ignition ON or engine running, DO NOT use air or electric power tools or strike near the sensor(s) with a hammer. Heavy vibration could activate the sensor(s) and deploy the air bag(s), possibly causing serious injury.
- When using air or electric power tools or hammers, always switch the ignition OFF, disconnect the battery, and wait at least 3 minutes before performing any service.

Service Notice or Precautions

INFOID:000000005038138

- Low tire pressure warning lamp blinks for 1min, then turns ON when occurring any malfunction except low tire pressure. Delete the memory with CONSULT-III, or register the ID to turn low tire pressure warning lamp OFF. Refer to [WT-12, "AIR PRESSURE MONITOR : Diagnosis Description"](#), [WT-6, "ID REGISTRATION PROCEDURE : Special Repair Requirement"](#).
- ID registration is required when replacing or rotating wheels, replacing transmitter or BCM. Refer to [BCS-82, "Exploded View"](#).
- Replace grommet seal, valve core and cap of transmitter in TPMS every tire replacement by reaching wear limit of tire. Refer to [WT-94, "Exploded View"](#).

PREPARATION

< PREPARATION >

[REGULAR GRADE]

PREPARATION

PREPARATION

Special Service Tool

INFOID:000000005038139

The actual shapes of Kent-Moore tools may differ from those of special service tools illustrated here.

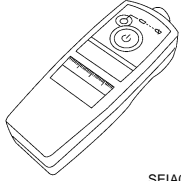
Tool number (Kent-Moore No.) Tool name	Description
- (J-45295) Transmitter activation tool  SEIA0462E	ID registration

Commercial Service Tool

INFOID:000000005038140

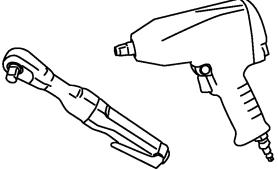
Tool name	Description
Power tool  PBIC0190E	Loosening wheel nuts

PERIODIC MAINTENANCE

ROAD WHEEL

Inspection

INFOID:000000005038141

ALUMINUM WHEEL

1. Check tires for wear and improper inflation.
2. Check wheels for deformation, cracks and other damage. If deformed, remove wheel and check wheel runout.
 - a. Remove tire from aluminum wheel and mount on a tire balance machine.
 - b. Set dial indicator as shown in the figure.
 - c. If the lateral deflection (A) or vertical deflection (B) for radial runout value exceeds the limit, replace aluminum wheel.

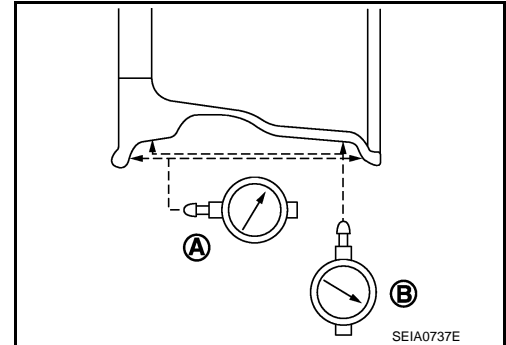

Limit

A: Refer to [WT-97, "Road Wheel"](#).

B: Refer to [WT-97, "Road Wheel"](#).

STEEL WHEEL

1. Check tires for were and improper inflation.
2. Check wheels for deformation, clacks and other damage. If deformed, remove wheel and check wheel runout.
 - a. Remove tire from steel wheel and mount wheel on a tire balance machine.
 - b. Set two dial indicators as shown in the illustration.
 - c. Set each dial indicator to "0".
 - d. Rotate wheel and check dial indicators at several points around the circumference of the wheel.
 - e. Calculate runout at each point as shown below.

Lateral runout limit (A): $(1+2)/2$

Radial runout limit (B): $(3+4)/2$

- f. Select maximum positive runout value and the maximum negative value. Add the two values to determine total runout.

CAUTION:

In case a positive or negative value is not available, use the maximum value (negative or positive) for total runout.

Limit

A: Refer to [WT-97, "Road Wheel"](#).

B: Refer to [WT-97, "Road Wheel"](#).

- g. If the total runout value exceeds limit, replace steel wheel.

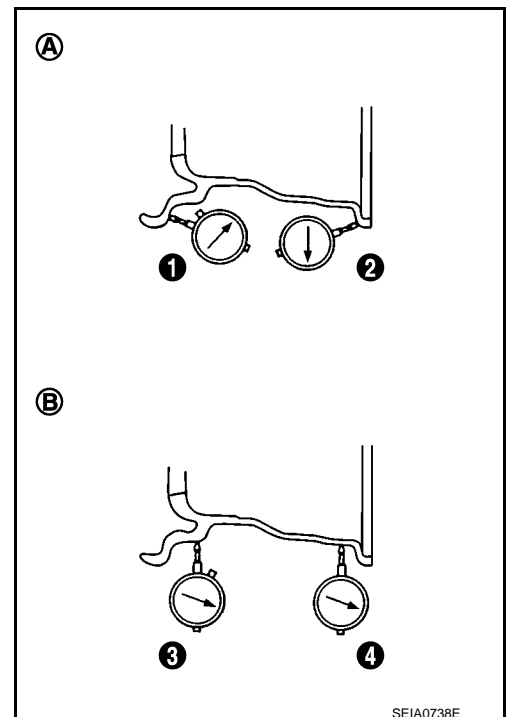

REMOVAL AND INSTALLATION

ROAD WHEEL TIRE ASSEMBLY

Exploded View

INFOID:000000005072091

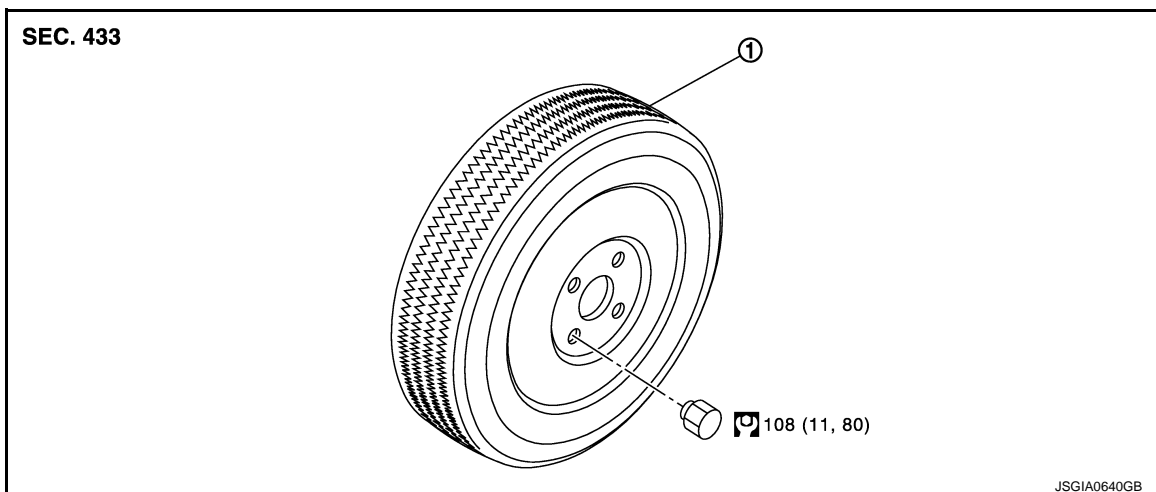

1. Tire assembly

Refer to [GI-4, "Components"](#) for symbols in the figure.

Removal and Installation

INFOID:000000005072092

REMOVAL

1. Remove wheel nuts.
2. Remove tire assembly.

INSTALLATION

Install in the reverse order of removal.

Adjustment

INFOID:000000005038142

BALANCING WHEELS (BONDING WEIGHT TYPE)

Preparation Before Adjustment

Using releasing agent, remove double-faced adhesive tape from the road wheel.

CAUTION:

- Be careful not to scratch the road wheel during removal.
- After removing double-faced adhesive tape, wipe clean traces of releasing agent from the road wheel.

Wheel Balance Adjustment

If a tire balance machine has adhesion balance weight mode settings and drive-in weight mode setting, select and adjust a drive-in weight mode suitable for road wheels.

1. Set road wheel on tire balance machine using the center hole as a guide. Start the tire balance machine.
2. When inner and outer unbalance values are shown on the tire balance machine indicator, multiply outer unbalance value by 5/3 to determine balance weight that should be used. Select the outer balance weight with a value closest to the calculated value above and install to the designated outer position of, or at the designated angle in relation to the road wheel.

CAUTION:

- Do not install the inner balance weight before installing the outer balance weight.
- Before installing the balance weight, be sure to clean the mating surface of the road wheel.

ROAD WHEEL TIRE ASSEMBLY

< REMOVAL AND INSTALLATION >

[REGULAR GRADE]

- a. Indicated unbalance value $\times 5/3 =$ balance weight to be installed

Calculation example:

23 g (0.81 oz) $\times 5/3 = 38.33$ g (1.35 oz) \Rightarrow 40 g (1.41 oz) balance weight (closer to calculated balance weight value)

NOTE:

Note that balance weight value must be closer to the calculated balance weight value.

Example:

37.4 \Rightarrow 35 g (1.23 oz)

37.5 \Rightarrow 40 g (1.41 oz)

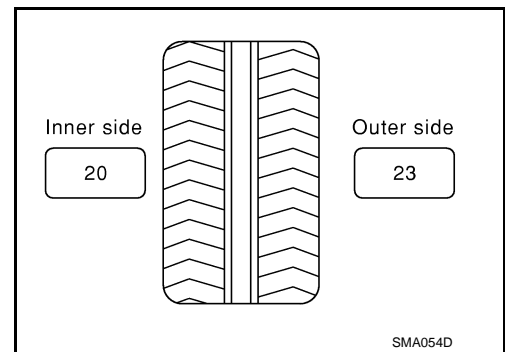

- b. Installed balance weight in the position.

- When installing balance weight (1) to road wheels, set it into the grooved area (A) on the inner wall of the road wheel as shown in the figure so that the balance weight center (B) is aligned with the tire balance machine indication position (angle) (C).

CAUTION:

- Always use genuine NISSAN adhesion balance weights.
- Balance weights are non-reusable; always replace with new ones.
- Do not install more than three sheets of balance weight.

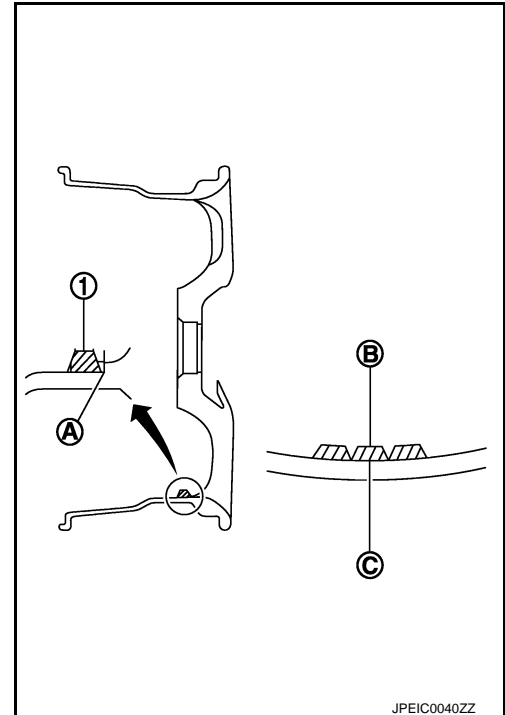

- c. If calculated balance weight value exceeds 50 g (1.76 oz), install two balance weight sheets in line with each other as shown in the figure.

CAUTION:

Do not install one balance weight sheet on top of another.

3. Start the tire balance machine again.
4. Install drive-in balance weight on inner side of road wheel in the tire balance machine indication position (angle).

CAUTION:

Do not install more than two balance weight.

5. Start the tire balance machine. Make sure that inner and outer residual unbalance values are 10 g (0.35 oz) each or below.
6. If either residual unbalance value exceeds 10 g (0.35 oz), repeat installation procedures.

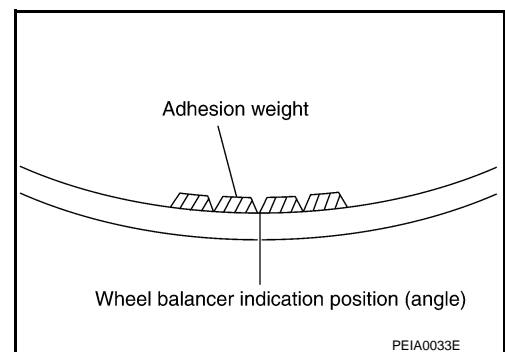

Limit

Dynamic (At flange) : Refer to [WT-97, "Road Wheel"](#).

Static (At flange) : Refer to [WT-97, "Road Wheel"](#).

TIRE ROTATION

ROAD WHEEL TIRE ASSEMBLY

< REMOVAL AND INSTALLATION >

[REGULAR GRADE]

- Follow the maintenance schedule for tire rotation service intervals. Refer to [MA-4, "Explanation of General Maintenance"](#).
- When installing the wheel, tighten wheel nuts to the specified torque.

CAUTION:

- **When installing wheels, tighten them diagonally by dividing the work two to three times in order to prevent the wheels from developing any distortion.**
- **Be careful not to tighten wheel nut at torque exceeding the criteria for preventing strain of disc rotor.**
- **Use NISSAN genuine wheel nuts for aluminum wheels.**

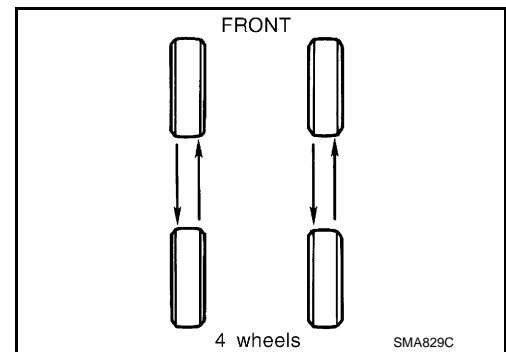

Wheel nuts tightening torque : Refer to [WT-91, "Exploded View"](#).

A
B
C
D

WT

F
G
H
I
J
K
L
M
N
O
P

TRANSMITTER

< REMOVAL AND INSTALLATION >

[REGULAR GRADE]

TRANSMITTER

Exploded View

INFOID:000000005038143

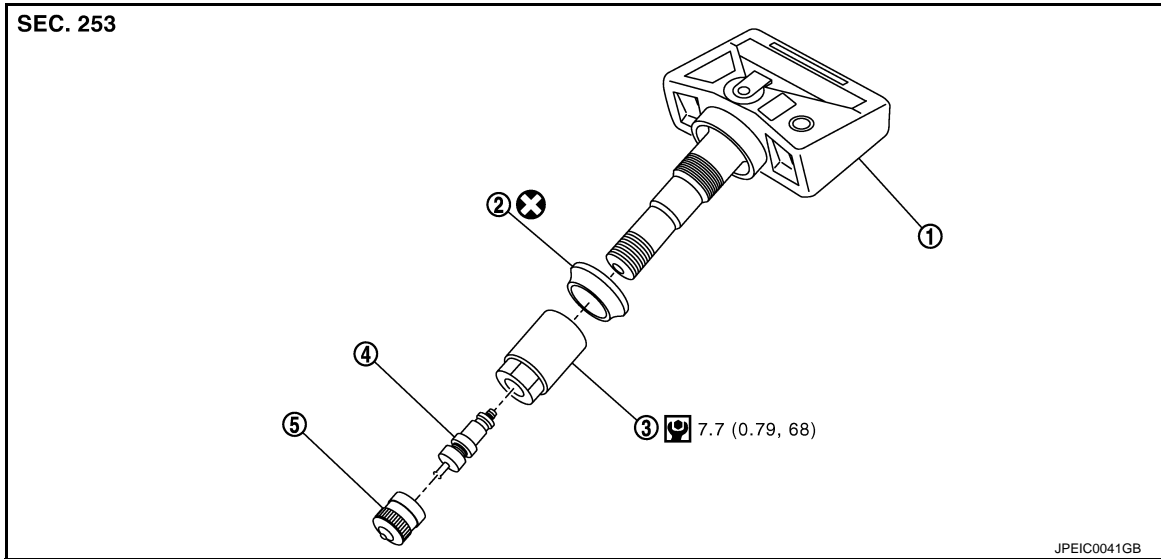

- | | | |
|----------------|-----------------|--------------|
| 1. Transmitter | 2. Grommet seal | 3. Valve nut |
| 4. Valve core | 5. Cap | |

Refer to [GI-4, "Components"](#) for symbols in figure.

Removal and Installation

INFOID:000000005038144

REMOVAL

1. Deflate tire. Unscrew transmitter retaining nut and allow transmitter to fall into tire.
2. Gently bounce tire so that transmitter falls to bottom of tire. Place on tire changing machine and break both tire beads ensuring that the transmitter remains at the bottom of the tire.

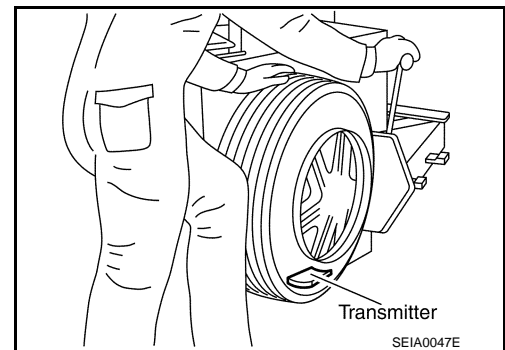

3. Turn tire so that valve hole is at bottom and bounce so that transmitter (1) is near valve hole. Carefully lift tire onto turntable and position valve hole (and transmitter) 270 degree from mounting/dismounting head (2).
4. Lubricate tire well and remove first side of the tire. Reach inside the tire and remove the transmitter.

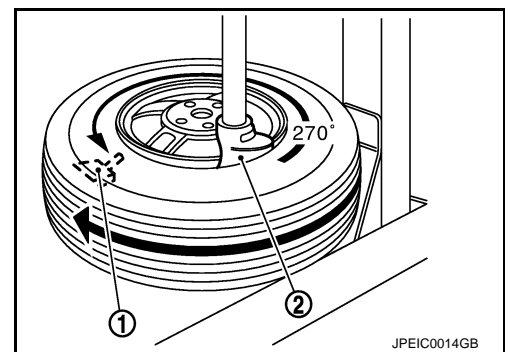

INSTALLATION

TRANSMITTER

< REMOVAL AND INSTALLATION >

[REGULAR GRADE]

1. Put first side of tire onto rim.

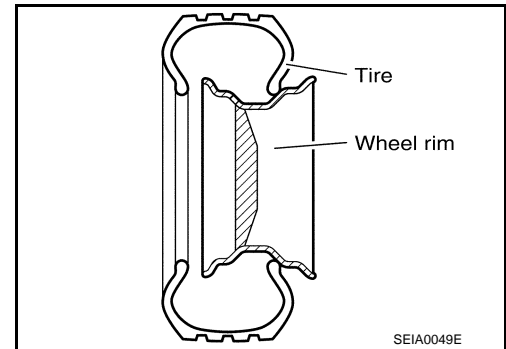

2. Mount transmitter on rim and tighten nut.

CAUTION:

Speed for tightening nut should be less than 10 rpm.

3. Place wheel on turntable of tire machine. Ensure that transmitter (1) is 270 degree from mounting head (2) when second side of tire is fitted.

NOTE:

Do not touch transmitter at mounting head.

4. Lubricate tire well and fit second side of tire as normal. Ensure that tire does not rotate relative to rim.
5. Inflate tire and fit to appropriate wheel position.

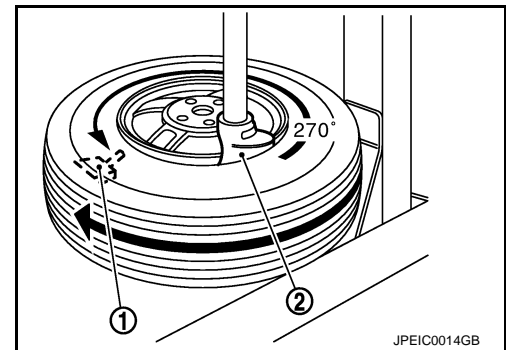

A
B
C
D

WT

F
G
H
I
J
K
L
M
N
O
P

TIRE PRESSURE RECEIVER

< REMOVAL AND INSTALLATION >

[REGULAR GRADE]

TIRE PRESSURE RECEIVER

Exploded View

INFOID:000000005038145

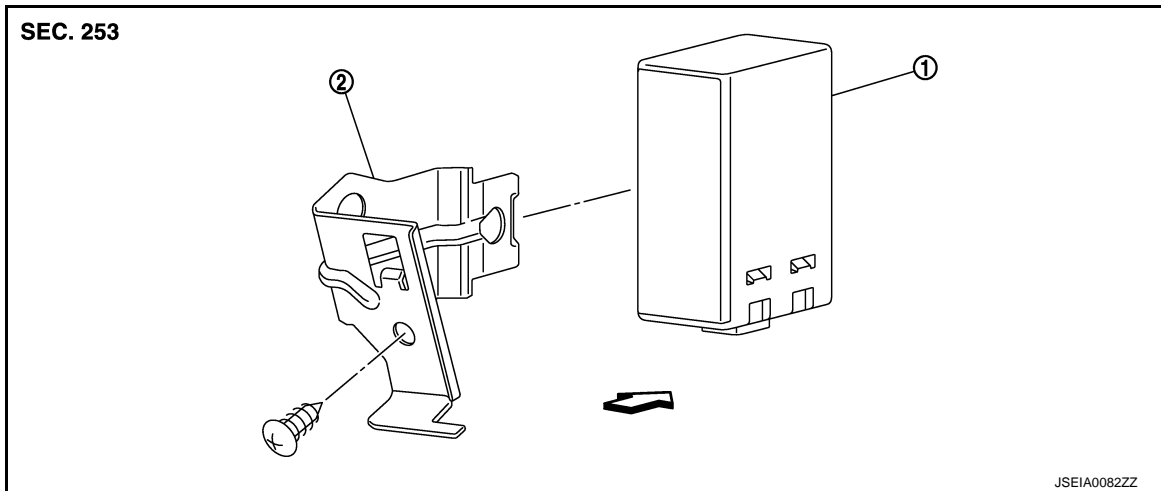

1. Tire pressure receiver

2. Bracket

← Vehicle front

Removal and Installation

INFOID:000000005038146

REMOVAL

1. Remove the glove box assembly. Refer to [IP-12, "Exploded View"](#).
2. Remove the glove box cover. Refer to [IP-12, "Exploded View"](#).
3. Disconnect tire pressure receiver harness connector.
4. Remove tire pressure receiver mounting screw.
5. Remove tire pressure receiver.

INSTALLATION

Install is the reverse order of removal.

SERVICE DATA AND SPECIFICATIONS (SDS)

< SERVICE DATA AND SPECIFICATIONS (SDS)

[REGULAR GRADE]

SERVICE DATA AND SPECIFICATIONS (SDS)

SERVICE DATA AND SPECIFICATIONS (SDS)

Road Wheel

INFOID:000000005038147

ALUMINUM WHEEL

Item		Limit
Radial runout	Lateral deflection	Less than 0.3 mm (0.012 in)
	Vertical deflection	
Allowable unbalance	Dynamic (At flange)	Less than 10 g (0.35 oz) (one side)
	Static (At flange)	Less than 20 g (0.70 oz)

STEEL WHEEL

Item		Limit	
Radial runout	Conventional	Lateral deflection	Less than 0.8 mm (0.031 in)
		Vertical deflection	Less than 0.5 mm (0.020 in)
	Emergency	Lateral deflection	Less than 1.2 mm (0.031 in)
		Vertical deflection	Less than 1.0 mm (0.020 in)
Allowable unbalance	Dynamic (At flange)	Less than 10 g (0.35 oz) (one side)	
	Static (At flange)	Less than 20 g (0.70 oz)	

Tire Air Pressure

INFOID:000000005038149

Unit: kPa (kg/cm², psi)

Tire size	Air pressure	
	Front	Rear
P195/60R15 87H	230 (2.3, 33)	230 (2.3, 33)
P195/55R16 86V	230 (2.3, 33)	230 (2.3, 33)
T125/70D15 95M	420 (4.2, 60)	420 (4.2, 60)

ROAD WHEEL TIRE ASSEMBLY

< SPEC CHANGE INFORMATION >

[Krom]

SPEC CHANGE INFORMATION

ROAD WHEEL TIRE ASSEMBLY

Road Wheel Tire Assembly

INFOID:000000005156108

The wheels are made of specifically-designed bright aluminum with their surface treated with sputtering coating.

Z12 Krom	Item	Data
Aluminum road wheels	Size	16 × 6J
	Offset	+ 1.65 in (+42 mm)
	P. C. D.	4.5 in (114.3 mm)
Tires	Tire size	195/ 55R16 86V

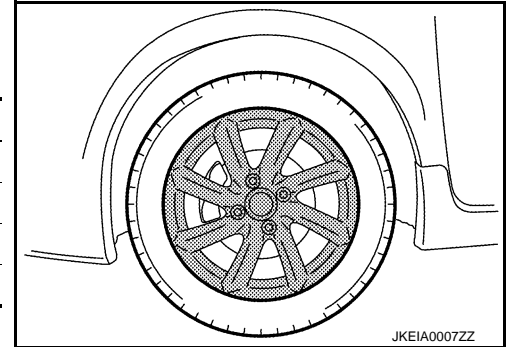

CAUTION:

- Wheels with sputtering coating are not plated wheels. Never use a cleaner for plating, abrasive cleanser, and brush. (Since sputtering is one of the methods of metallic coating, the surface treatment may be subject to damage, peel, or corrosion.)
- Wash regularly with a sponge dampened in a mild soap solution, especially during winter months in areas where road salt is used. Salt could discolor the wheels if not removed.