

# BRAKE SYSTEM

## SECTION **BR**

### CONTENTS

|   |       |
|---|-------|
| BRAKE HYDRAULIC LINE .....                        | BR- 2 |
| BRAKE PEDAL .....                                 | BR- 4 |
| MASTER CYLINDER .....                             | BR- 6 |
| BRAKE BOOSTER.....                                | BR- 7 |
| FRONT DISC BRAKE (CL28VA, CL28VB) – Caliper ..... | BR- 9 |
| FRONT DISC BRAKE (CL28VA, CL28VB) – Rotor .....   | BR-11 |
| REAR DISC BRAKE (CL14H, CL14HB) – Caliper .....   | BR-12 |
| REAR DISC BRAKE – Rotor .....                     | BR-16 |
| PARKING BRAKE .....                               | BR-17 |
| SERVICE DATA AND SPECIFICATIONS (S.D.S.).....     | BR-19 |
| SPECIAL SERVICE TOOL .....                        | BR-21 |

# BRAKE HYDRAULIC LINE

## Precautions

- Recommended fluid is brake fluid "DOT 3".
- Do not reuse drained brake fluid.
- Be careful not to splash brake fluid on painted areas.

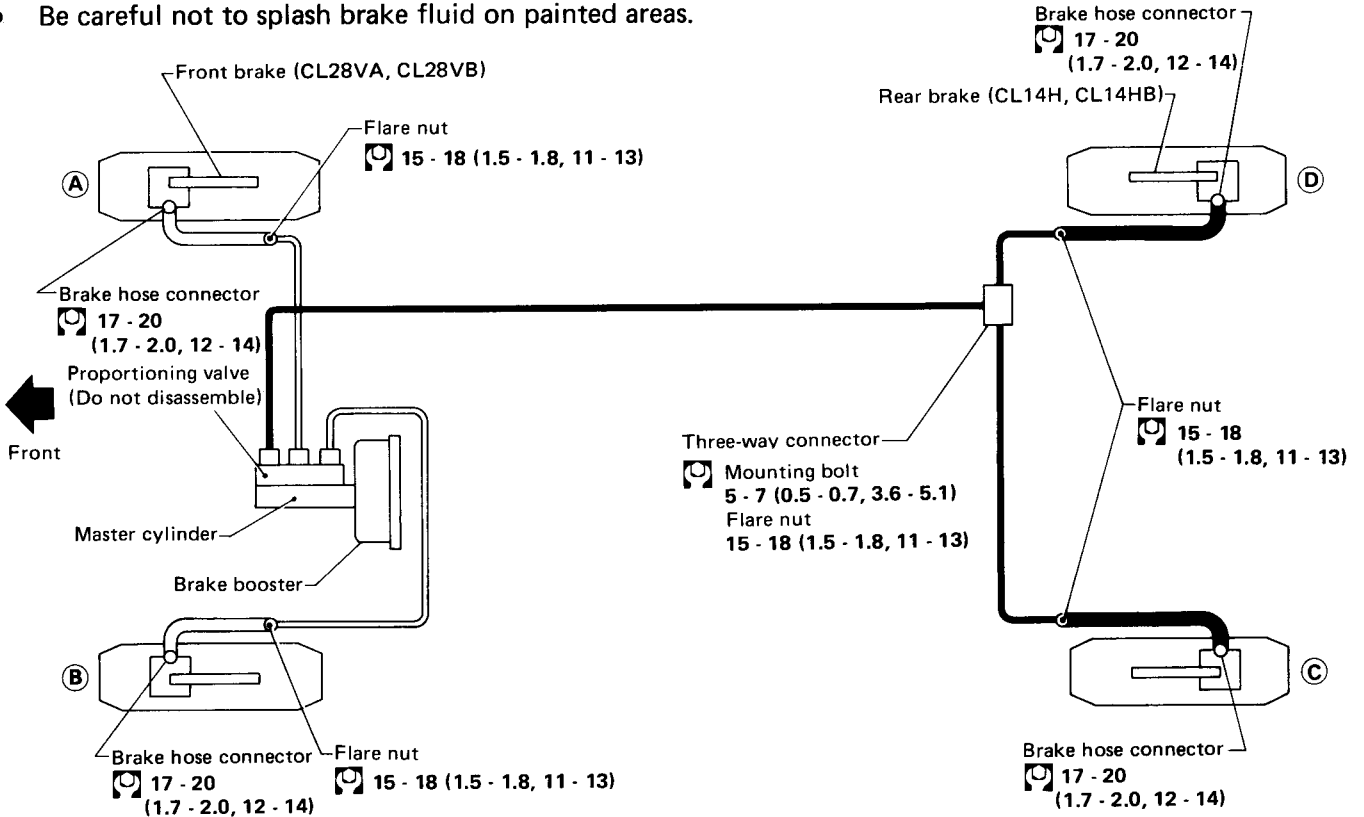

### WARNING:

Clean pad and shoe dust using a dust collector after cleaning with waste cloth.

SBR821

## Bleeding Procedure

### PRECAUTIONS

Carefully monitor brake fluid level at master cylinder during bleeding operation.

- Bleed air according to the following procedure:  
 Left rear caliper ③ → Right rear caliper ④  
 → Right front caliper ① → Left front caliper ②
- Connect a transparent vinyl tube to air bleeder valve of caliper.

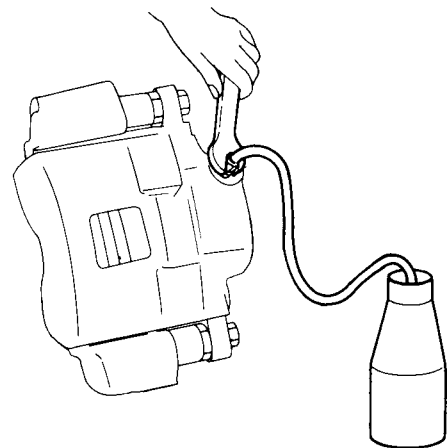

SBR606

# BRAKE HYDRAULIC LINE

## Removal and Installation

## Inspection

### CAUTION :

- a. When removing and installing brake tube, use Tool.

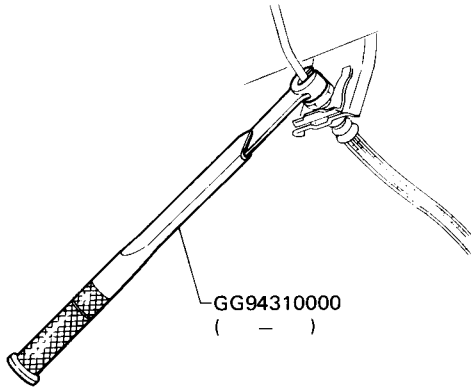

SBR500

- b. Cover openings to prevent entrance of dirt whenever disconnecting hydraulic line.
- To remove brake hose, first remove flare nut securing brake tube to hose, then withdraw lock spring. Next disconnect the other side.
  - All hoses must be free from excessive bending, twisting and pulling.
  - Whenever installing brake lines, be sure to check for oil leakage by fully depressing brake pedal.

Check brake lines (tubes and hoses) for evidence of cracks, deterioration or other damage. Replace any damaged parts.

If leakage occurs around connectors re-tighten or, if necessary, replace damaged parts.

# BRAKE PEDAL

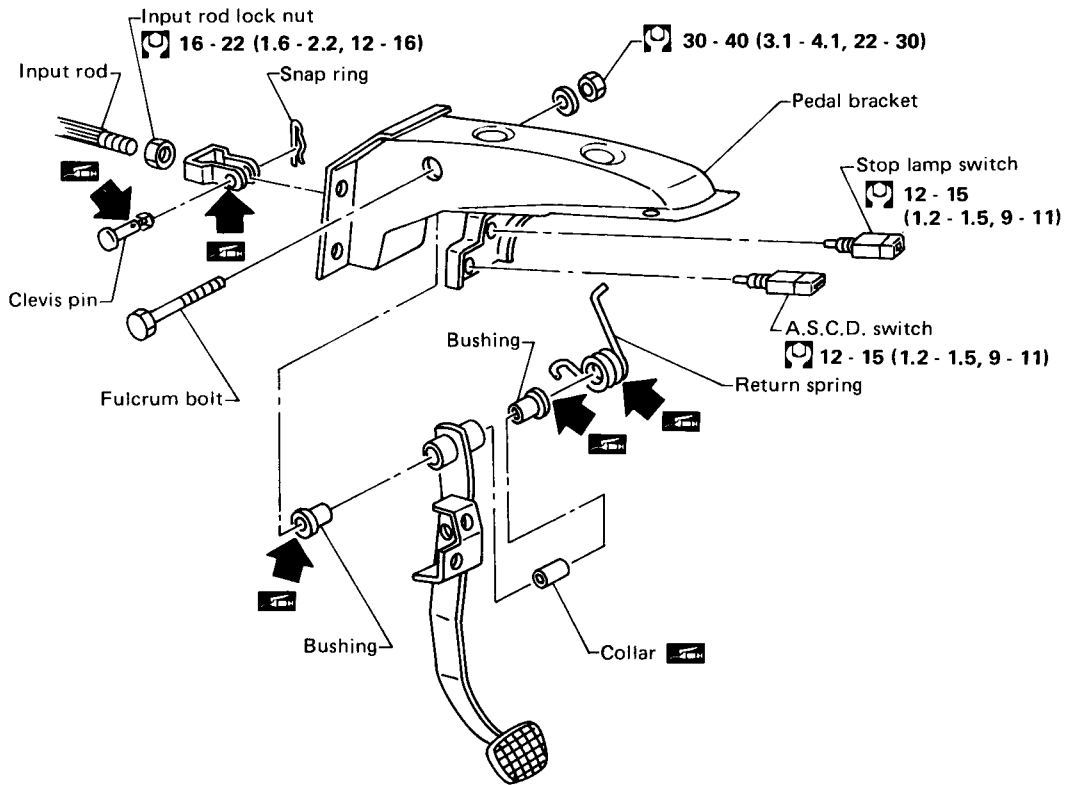

 : N·m (kg·m, ft·lb)

SB R822

## Inspection

Check brake pedal for the following items, servicing as necessary.

- Brake pedal bend
- Clevis pin deformation
- Crack of any welded portion

# BRAKE PEDAL

## Adjustment

Check brake pedal free height from melt sheet.  
Adjust if necessary.

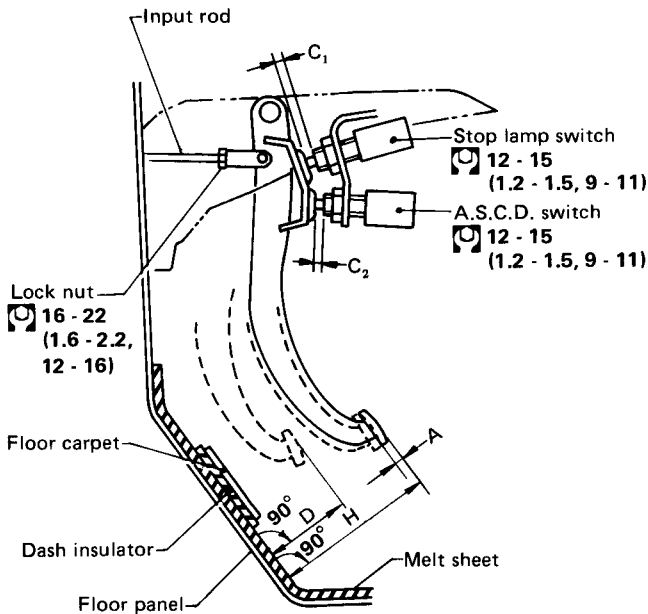

⊗ : N·m (kg-m, ft-lb)

SBR838

### H: Free height

M/T 182 - 192 mm (7.17 - 7.56 in)

A/T 184 - 194 mm (7.24 - 7.64 in)

### D: Depressed height

M/T 90 mm (3.54 in) or more

A/T 90 mm (3.54 in) or more

Under force of 490 N (50 kg, 110 lb) with engine running.

C<sub>1</sub>: Clearance between pedal stopper and threaded end of stop lamp switch.

0.3 - 1.0 mm (0.012 - 0.039 in)

C<sub>2</sub>: Clearance between pedal stopper and threaded end of A.S.C.D. switch.

0.3 - 1.0 mm (0.012 - 0.039 in)

A: Pedal free play

1.0 - 3.0 mm (0.039 - 0.118 in)

(1) Adjust pedal free height with brake booster input rod. Then tighten lock nut.

Be sure that tip of input rod stays inside.

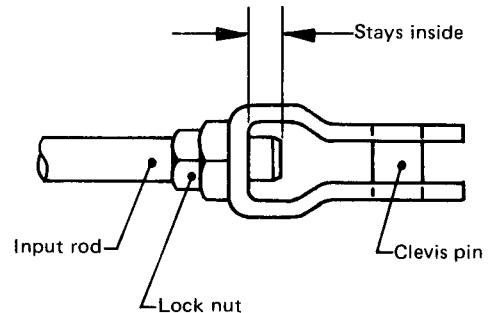

SBR930

(2) Adjust clearance "C<sub>1</sub>" and "C<sub>2</sub>" with stop lamp switch and A.S.C.D. switch respectively. Then tighten lock nuts.

(3) Check pedal free play.

Make sure that stop lamp is off when pedal is released.

(4) Check brake pedal depressed height with engine running.

If depressed height is below the specified value, check brake system for leaks, accumulation of air or any damage regarding component parts (master cylinder, wheel cylinder, etc.), and make the necessary repairs.

# MASTER CYLINDER

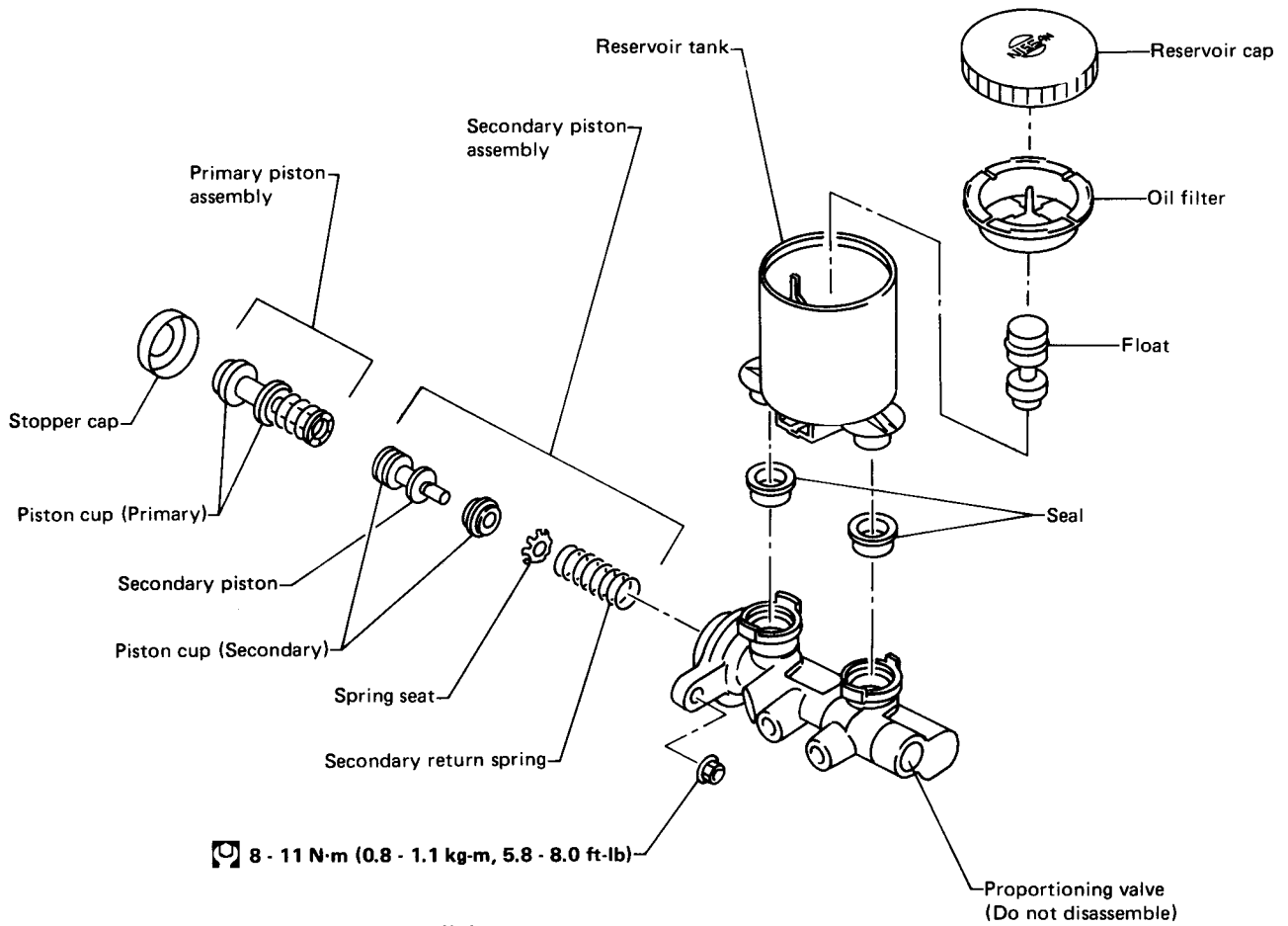

- Apply brake fluid or rubber grease to sliding contact surface when assembling master cylinder.
- Check parts for wear or damage. Replace if any of above conditions are observed.
- Replace piston assembly when disassembled.

SBR823

# BRAKE BOOSTER

## Operating Check

- Depress brake pedal several times with engine off, then check that there is no change in pedal stroke.
- Depress brake pedal, then start engine. If pedal goes down slightly, operation is normal.

## Airtight Check

- Start engine, then stop it in one or two minutes. Depress brake pedal several times slowly. If pedal goes further down the first time, but gradually rises after second or third time, the booster is airtight.
- Depress brake pedal while engine is running, then stop it with pedal depressed. If there is no change in pedal stroke after holding pedal for thirty seconds, brake booster is airtight.

## Removal and Installation

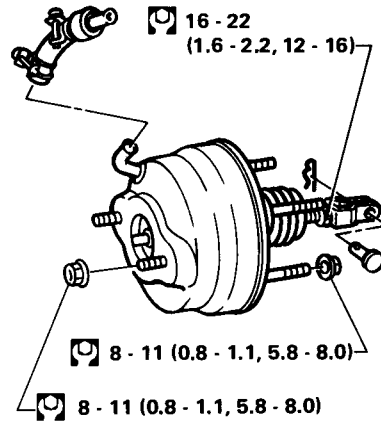

 : N·m (kg·m, ft·lb)

SBR831

# BRAKE BOOSTER

## Inspection

### HOSES AND CONNECTORS

- Check condition of vacuum hoses and connectors.
- Check vacuum hoses and check valve for air tightness.
- Do not apply any oil or lubricants to vacuum hose and check valve.

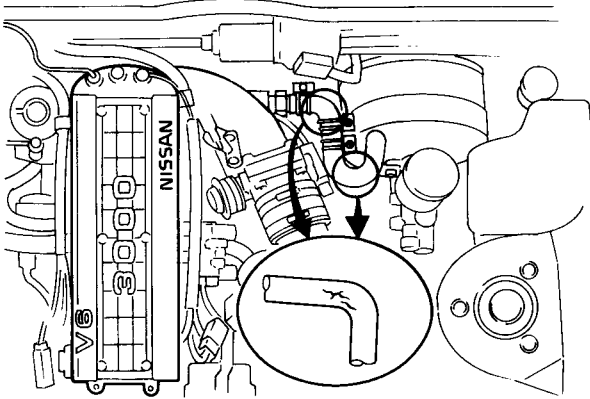

SBR986

### CHECK VALVE

- When pressure is applied to the brake booster side of check valve and valve does not open, replace check valve with a new one.

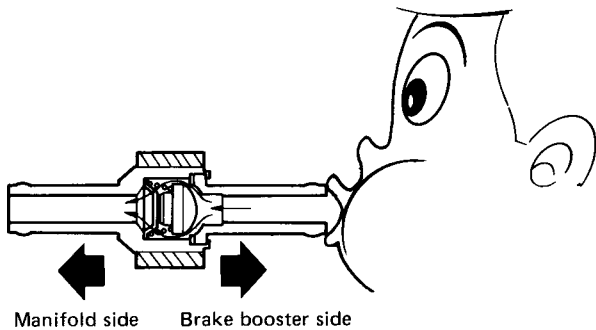

SBR846

### OUTPUT ROD LENGTH

Output rod length does not require adjustment.

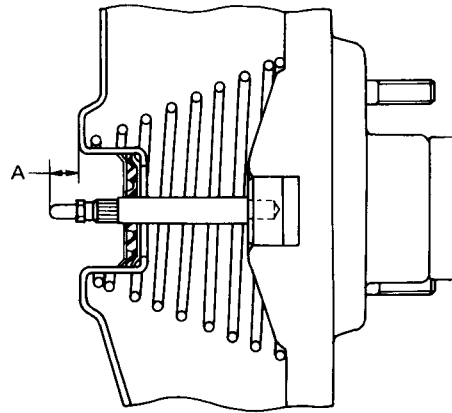

SBR426



# FRONT DISC BRAKE (CL28VA, CL28VB) — Caliper

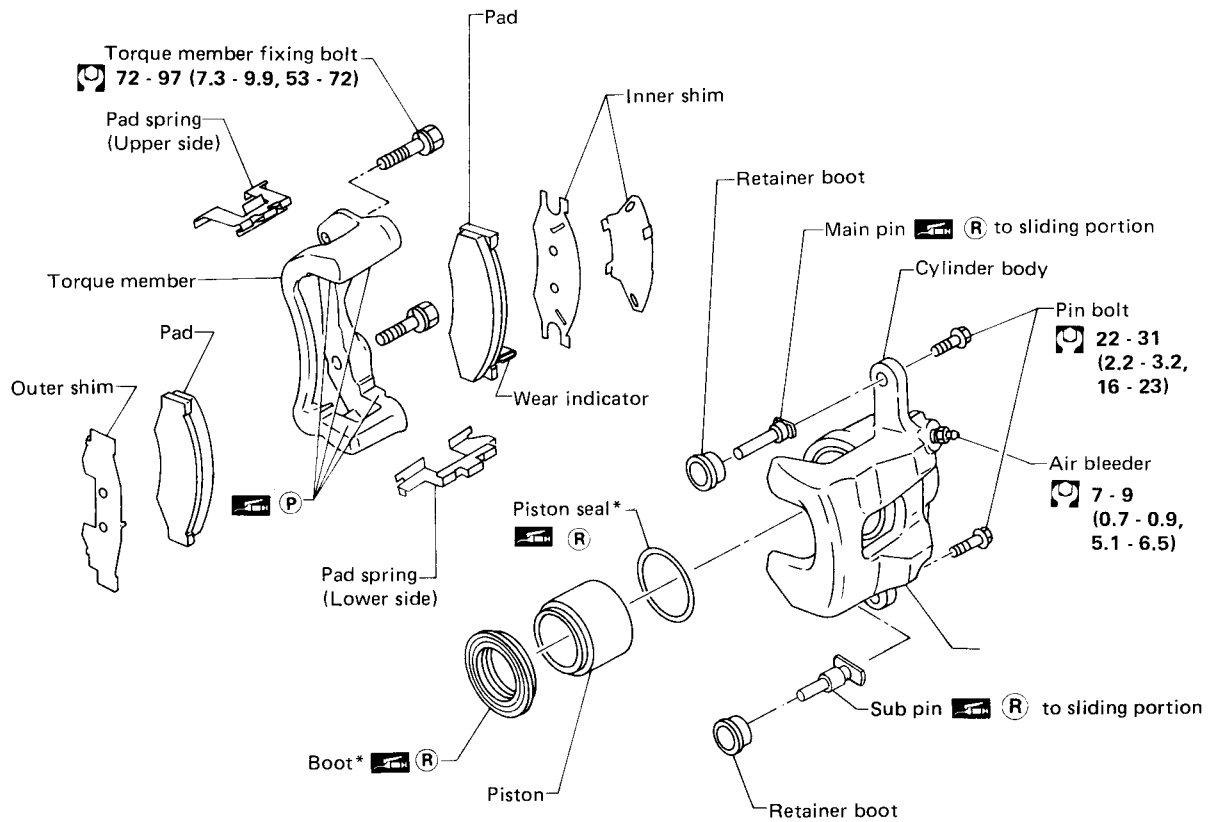

- (P) : P.B.C. (Poly Butyl Cuprysil) grease or silicone-based grease point
- (R) : Rubber grease points
- \* : Always replace when disassembled.

: N·m (kg·m, ft·lb)

SBR157A

## Pad Replacement

### CAUTION:

When cylinder body is swung up, do not depress brake pedal because piston will pop out.

1. Remove brake hose lock spring and pin bolt.

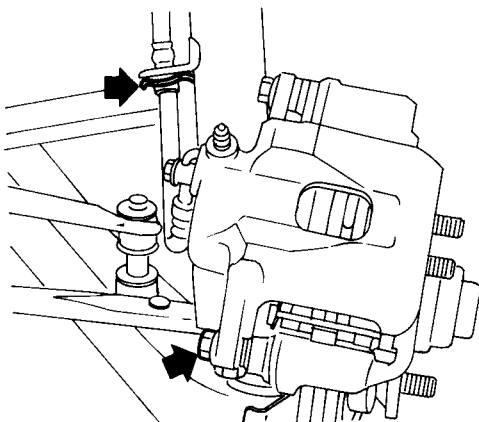

SBR988

2. Swing cylinder body upward. Then remove pad retainer and inner and outer shims.

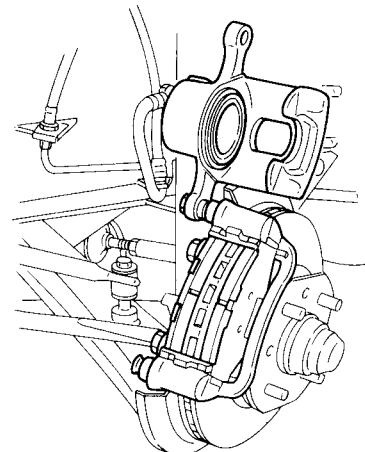

SBR825

Be careful not to damage piston boot or get oil on rotor. Always replace shims when replacing pads.

# FRONT DISC BRAKE (CL28VA, CL28VB) — Caliper

## Removal and Installation

Remove torque member fixing bolts and brake hose connector.

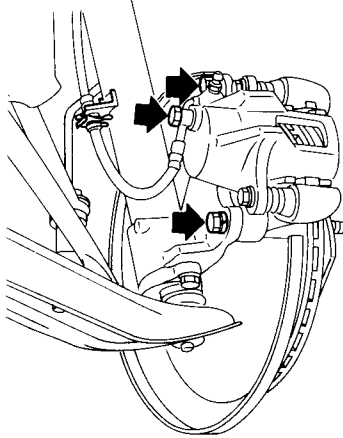

SBR839

## Disassembly

Push out piston with dust seal using compressed air.

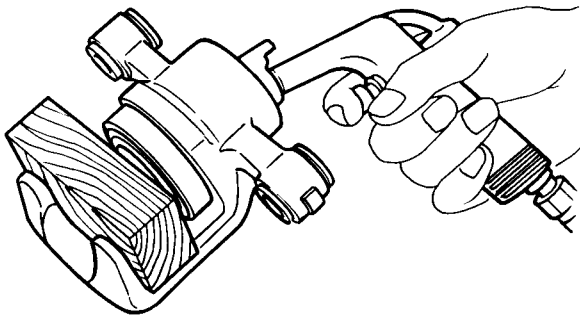

SBR772

## Inspection

### CAUTION:

Use brake fluid to clean. Never use mineral oil.

### CYLINDER BODY

- Check inside surface of cylinder for score, rust, wear, damage or presence of foreign materials. If any of the above conditions are observed, replace cylinder body.
- Minor damage from rust of foreign materials may be eliminated by polishing surface with a fine emery paper. Replace cylinder body if necessary.

### PISTON

Check piston for score, rust, wear, damage or presence of foreign materials. Replace if any of the above conditions are observed.

### CAUTION:

Piston sliding surface is plated. Do not polish with emery paper even if rust or foreign materials are stuck to sliding surface.

### PIN, PIN BOLT, RETAINER BOOT, RUBBER BUSHING, RETAINER BUSHING, AND PIN BOOT

Check for wear, cracks or other damage. Replace if any of the above conditions are observed.

## Assembly

- With dust seal fitted to piston, insert dust seal into groove on cylinder body and install piston.
- Properly secure dust seal.
- Pay attention to piston seal direction.

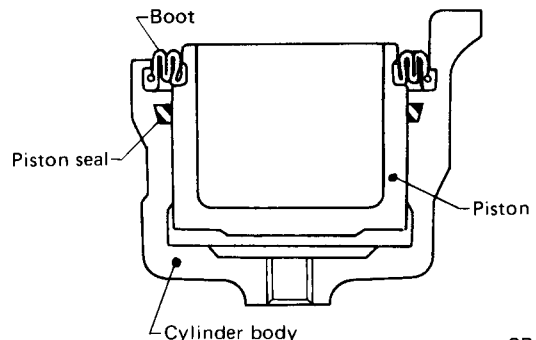

SBR574

# FRONT DISC BRAKE (CL28VA, CL28VB) — Rotor

## Inspection

### RUBBING SURFACE

Check rotor for roughness, cracks or chips.

### RUNOUT

Make sure axle shaft has no axial end play. Then check runout with a dial indicator.

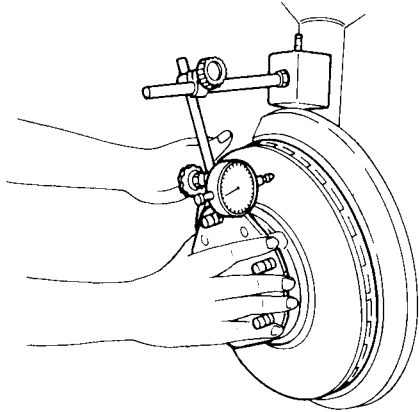

SBR158A

### Rotor repair limit:

**Maximum runout**  
(Total indicator reading at  
center of rotor pad contact surface)  
**0.07 mm (0.0028 in)**

### THICKNESS

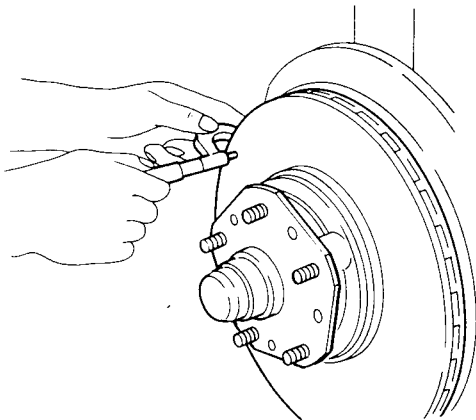

SBR159A

### Rotor repair limit:

**Minimum thickness**  
**20.0 mm (0.787 in)**

# REAR DISC BRAKE (CL14H, CL14HB) — Caliper

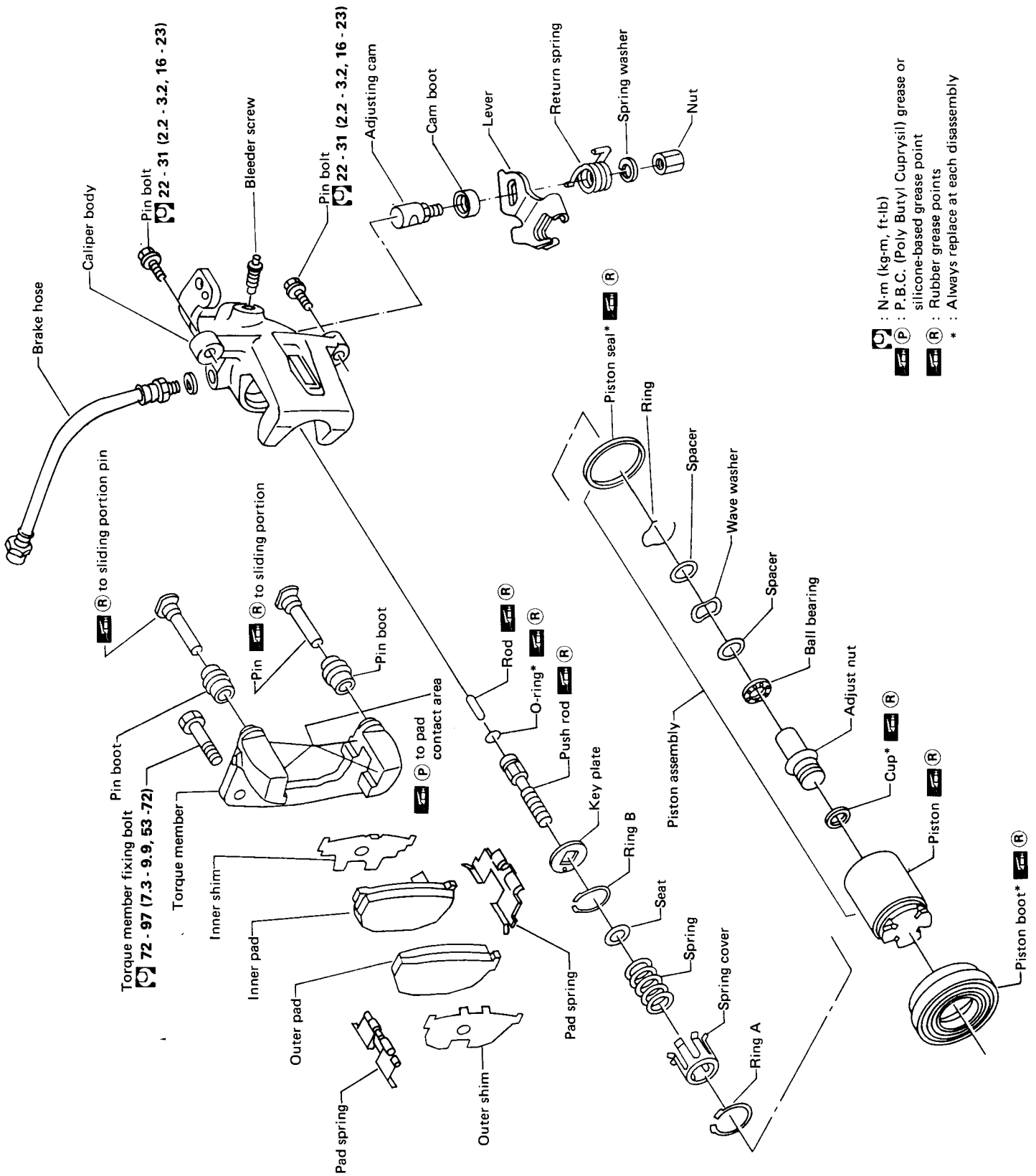

- : N·m (kg-m, ft-lb)
- : P.B.C. (Poly Butyl Cuprysil) grease or silicone-based grease point
- : Rubber grease points
- \* : Always replace at each disassembly

SBR151A

# REAR DISC BRAKE (CL14H, CL14HB) — Caliper

## Pad Replacement

### CAUTION:

When cylinder body is swung up, do not depress brake pedal because piston will pop out.

1. Disconnect parking brake cable, then remove pin bolts.

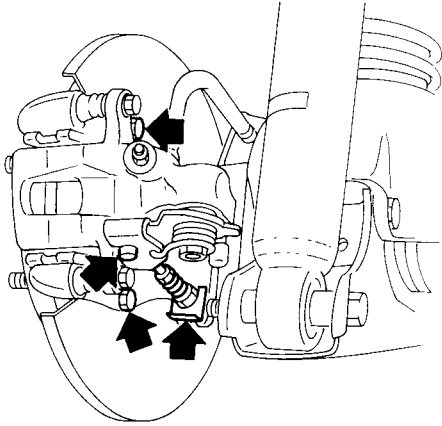

SBR166A

2. Remove pad retainer, pads and shims.

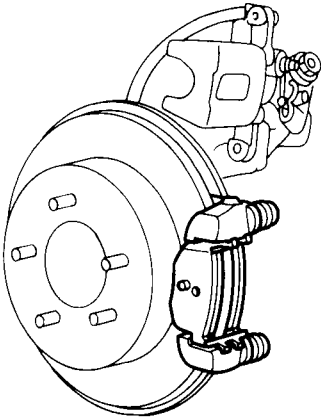

SBR160A

3. When installing pads, retract piston into cylinder body by turning it clockwise.

Be careful not to damage piston boot or get oil on rotor.

Always replace shims when replacing pads.

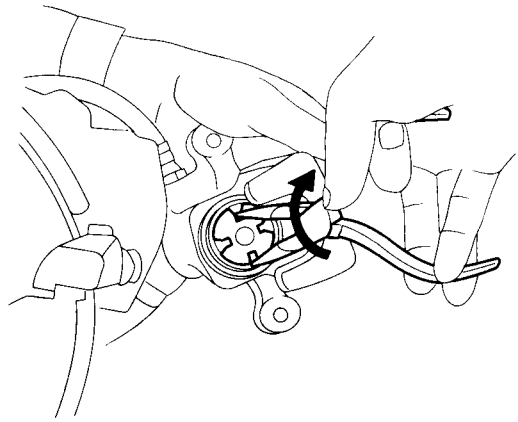

SBR641

## Removal and Installation

Disconnect parking brake cable and brake hose, then remove caliper assembly.

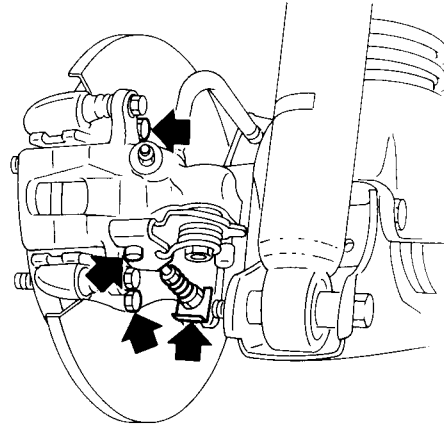

SBR166A

# REAR DISC BRAKE (CL14H, CL14HB) — Caliper

## Disassembly

1. Remove piston by turning it counterclockwise with suitable long nose pliers.

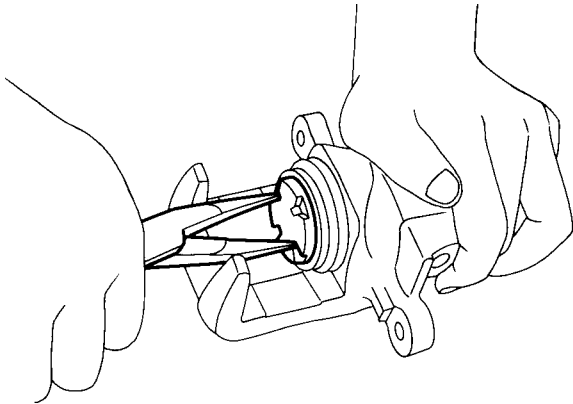

SBR646

- (2) Pry off ring B, then remove key plate, push rod and rod.

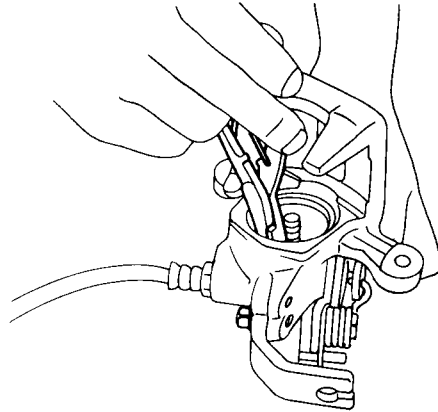

SBR164A

2. Pry off ring from piston and remove adjusting nut.

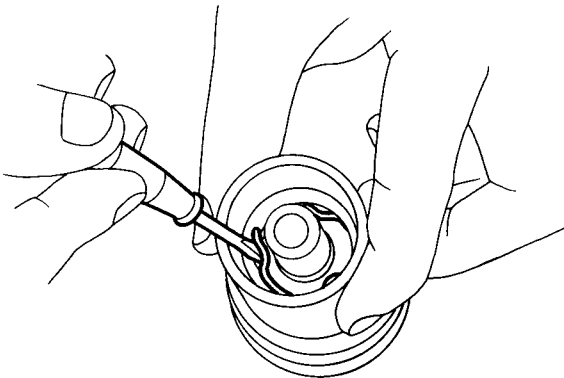

SBR648

- (3) Remove piston seal.  
Be careful not to damage cylinder body.

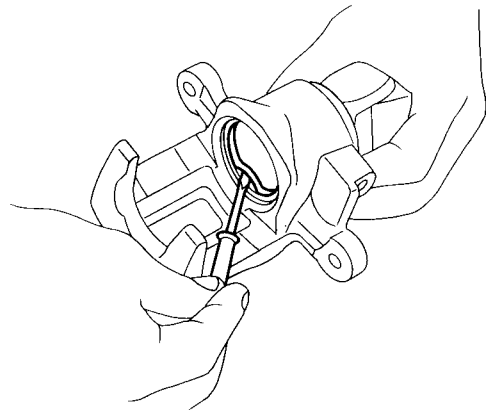

SBR656

3. Disassembly cylinder body.

- (1) Pry off ring A with suitable pliers, then remove spring cover, spring and seat.

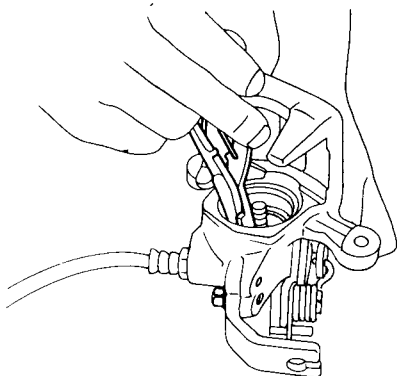

SBR148A

4. Remove return spring and lever.

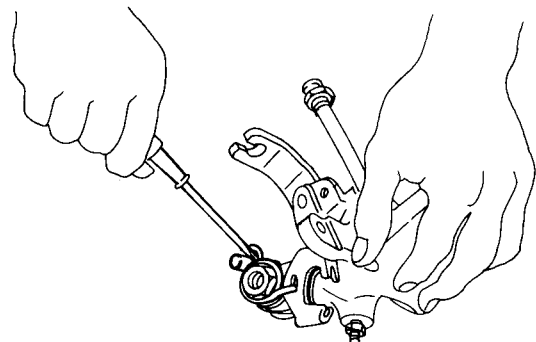

SBR149A

# REAR DISC BRAKE (CL14H, CL14HB) — Caliper

## Inspection

### CAUTION:

Use brake fluid to clean. Never use mineral oil.

### CYLINDER BODY

- Check inside surface of cylinder for score, rust, wear, damage or presence of foreign materials. If any of the above conditions are observed, replace cylinder body.
- Minor damage from rust or foreign materials may be eliminated by polishing surface with a fine emery paper. Replace cylinder body if necessary.

### TORQUE MEMBER

Check for wear, cracks or other damage. Replace if necessary.

### PISTON

Check piston for score, rust, wear, damage or presence of foreign materials. Replace if any wear or damage is found.

### CAUTION:

Piston sliding surface is plated. Do not polish with emery paper even if rust or foreign matter is stuck to sliding surface.

### PIN AND PIN BOOT

Check for wear, cracks or other damage. Replace if any of the above conditions are observed.

## Assembly

- Install cup securely in the specified direction.

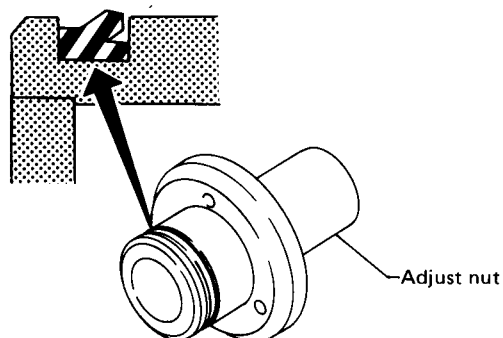

SBR849

- Fit push rod into square hole in key plate. Also match convex portion of key plate with concave portion of cylinder.

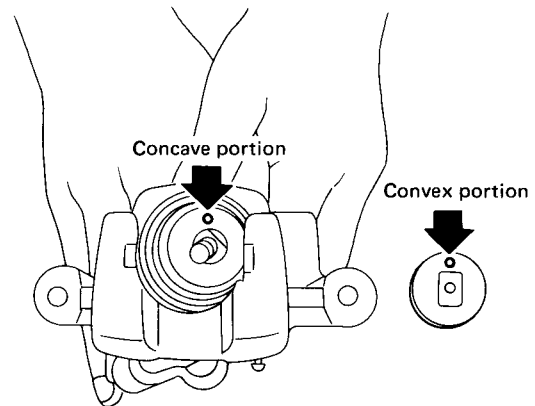

SBR842

- Install ring B with suitable tool.

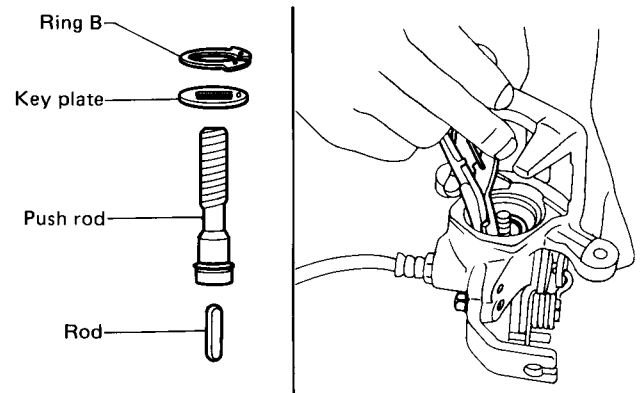

SBR165A

- Install seat, spring, spring cover and ring A with suitable press and drift.

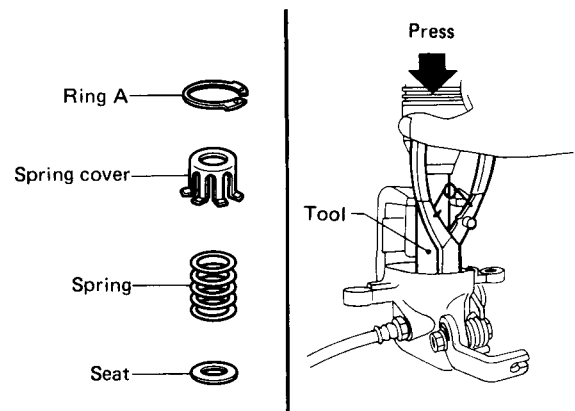

SBR150A

# REAR DISC BRAKE — Rotor

## Inspection

### RUBBING SURFACE

Check rotor for roughness, cracks or chips. Repair or replace if necessary.

### RUNOUT

Make sure that axial end play is within the specifications before measuring. Refer to section RA. Then check runout with a dial indicator.

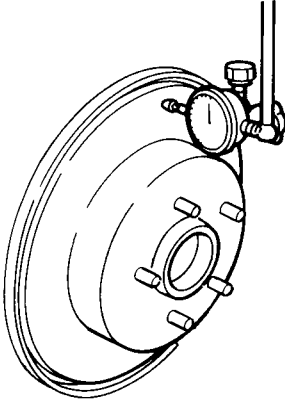

SBR161A

### Rotor repair limit:

#### Maximum runout

(Total indicator reading at center of rotor pad contact surface)

0.07 mm (0.0028 in)

### THICKNESS

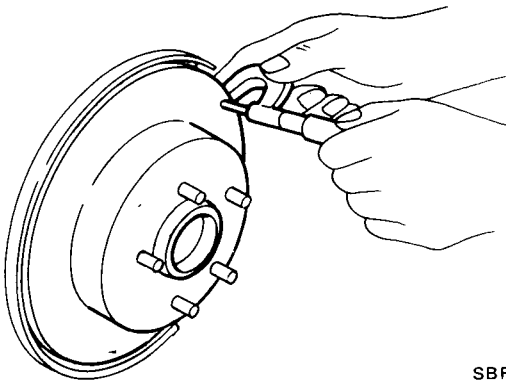

SBR162A

### Rotor repair limit:

#### Minimum thickness

9.0 mm (0.354 in)



# PARKING BRAKE

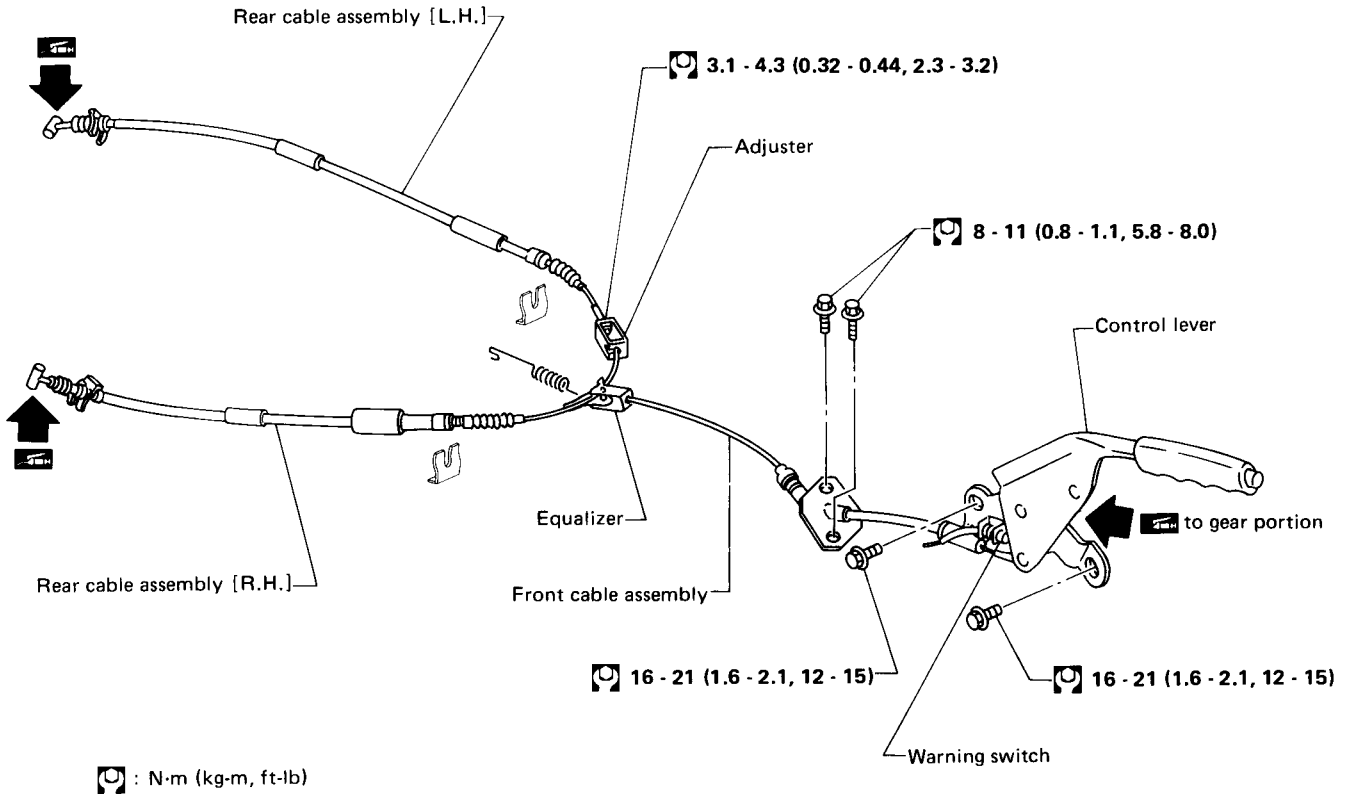

SBR163A

## Removal

If necessary, separate front cable from parking brake lever by breaking pin.

Front cable, clevis pin and cotter pin are available as service parts.

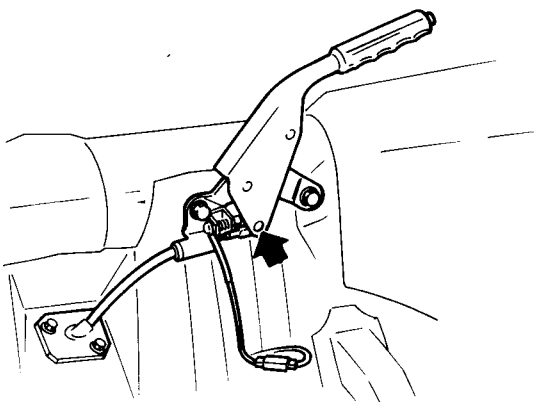

SBR835

## Inspection

1. Check control lever for wear or other damage. Replace if necessary.
2. Check wires for discontinuity or deterioration. Replace if necessary.
3. Check warning lamp and switch. Replace if necessary.
4. Check parts at each connecting portion and, if found deformed or damaged, replace.

# PARKING BRAKE

## Adjustment

### STROKE

- Pull lever with specified amount of force. Check lever stroke and ensure smooth operation.

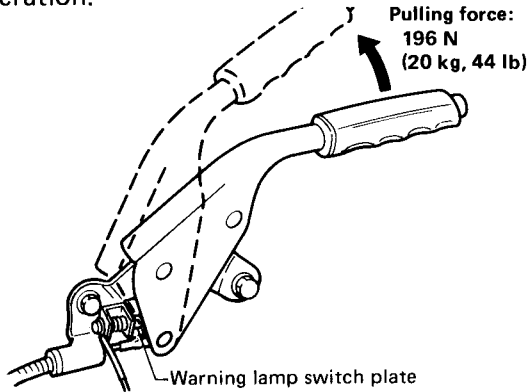

Number of notches: 8 - 10

SBR836

- Adjust lever stroke.

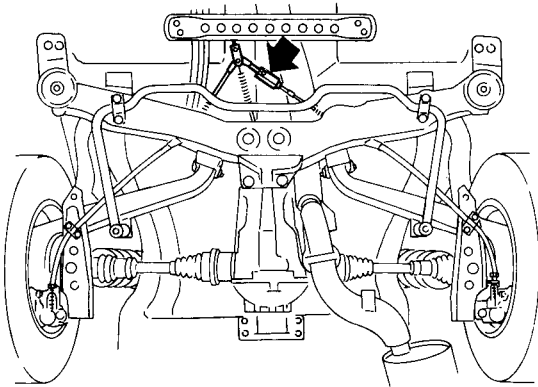

SBR837

### WARNING LAMP SWITCH

Bend parking brake warning lamp switch plate so that brake warning light comes on when ratchet at parking brake lever is pulled one notch and goes out when fully released.

# SERVICE DATA AND SPECIFICATIONS (S.D.S.)

## General Specifications

## Inspection and Adjustment

| Item                                       | Engine | VG30E   |                 | VG30ET      |
|--|--------|---|-----------------|-------------|
|  | Grade  | SF  | GL,<br>GL-L     | GL,<br>GL-L |
| Front brake                                |        |   |                 |             |
| Brake model                                |        | CL28VA  | CL28VB          |             |
| Pad  |        | Inner<br>43 x 11 x 126.5 (1.69 x 0.43 x 4.98)   |                 |             |
| Width x thickness x length mm (in)         |        | Outer<br>43 x 11 x 129.0 (1.69 x 0.43 x 5.08)   |                 |             |
| Rotor outer diameter mm (in)               |        | 250 (9.84)                                      | 274 (10.79)     |             |
| Caliper inner diameter mm (in)             |        | 60.6 (2.386)                                    |                 |             |
| Rear brake                                 |        |   |                 |             |
| Brake model                                |        | CL14H   | CL14HB          |             |
| Pad  |        | 40 x 8.0 x 75 (1.57 x 0.315 x 2.95)             |                 |             |
| Width x thickness x length mm (in)         |        |   |                 |             |
| Rotor outer diameter mm (in)               |        | 258 (10.16)                                     | 290 (11.42)     |             |
| Caliper inner diameter mm (in)             |        | 42.8 (1.685)                                    |                 |             |
| Master cylinder                            |        |   |                 |             |
| Inner diameter mm (in)                     |        | 23.81 (15/16)                                   |                 |             |
| Brake booster                              |        |   |                 |             |
| Model                                      |        | M20T  |                 |             |
| Diaphragm diameter mm (in)                 |        | Primary 205 (8.07)<br>Secondary 201 (7.91)      |                 |             |
| Control valve                              |        |   |                 |             |
| Model                                      |        | Proportioning valve<br>(within master cylinder) |                 |             |
| Sprit point kPa (kg/cm <sup>2</sup> , psi) |        | 3,923 (40, 569)                                 | 3,432 (35, 498) |             |
| Reducing ratio                             |        | 0.4   |                 |             |
| Recommended brake fluid                    |        | DOT 3   |                 |             |

### BRAKE PEDAL

|   |         |  |
|---|---------|--|
| Pedal ratio   |         | 3.8  |
| Free height   | mm (in) | M/T<br>182 - 192 (7.17 - 7.56)<br>A/T<br>184 - 194 (7.24 - 7.64) |
| Depressed height [Under force of 490 N (50 kg, 110 lb) with engine running] | mm (in) | 90 (3.54) or more  |
| Clearance between pedal stopper and threaded end of stop lamp switch        | mm (in) | 0.3 - 1.0 (0.012 - 0.039)  |
| Clearance between pedal stopper and threaded end of A.S.C.D. switch         | mm (in) |  |
| Pedal free play   | mm (in) | 1.0 - 3.0 (0.039 - 0.118)  |

### PARKING BRAKE

|   |                   |
|---|-------------------|
| Type  | Center lever type |
| Number of notches when warning lamp switch comes on                 | 1                 |
| Number of notches [When pulled under force of 196 N (20 kg, 44 lb)] | 8 - 10            |

### CHECK VALVE

|   |                  |
|---|------------------|
| Maximum vacuum leakage [15 seconds after 66.7 kPa (500 mmHg, 19.69 inHg) is applied.] | 1.3 (10, 0.39)   |
|   | kPa (mmHg, inHg) |

### BRAKE BOOSTER

|   |                  |
|---|------------------|
| Maximum vacuum leakage (15 seconds after engine is stopped) | 3.3 (25, 0.98)   |
|   | kPa (mmHg, inHg) |

# SERVICE DATA AND SPECIFICATIONS (S.D.S.)

## Inspection and Adjustment (Cont'd)

## Tightening Torque

### DISC BRAKE

| Brake model                                     | Front brake   |        | Rear brake    |        |
|---|---------------|--------|---------------|--------|
|   | CL28VA        | CL28VB | CL14H         | CL14HB |
| Pad wear limit<br>Minimum thickness<br>mm (in)  | 2 (0.08)      |        | 2 (0.08)      |        |
| Rotor repair limit<br>Maximum runout<br>mm (in) | 0.07 (0.0028) |        | 0.07 (0.0028) |        |
| Minimum thickness<br>mm (in)                    | 20.0 (0.787)  |        | 9.0 (0.354)   |        |

| Item                                      | N·m       | kg·m        | ft·lb     |
|---|-----------|-------------|-----------|
| <b>Brake pedal</b>                        |           |             |           |
| Pedal bracket to body                     | 8 - 11    | 0.8 - 1.1   | 5.8 - 8.0 |
| Pedal bracket to pedal                    | 30 - 40   | 3.1 - 4.1   | 22 - 30   |
| Stop lamp switch lock nut                 | 12 - 15   | 1.2 - 1.5   | 9 - 11    |
| <b>Brake booster</b>                      |           |             |           |
| Brake booster to body                     | 8 - 11    | 0.8 - 1.1   | 5.8 - 8.0 |
| Input rod lock nut                        | 16 - 22   | 1.6 - 2.2   | 12 - 16   |
| Brake booster to master cylinder          | 8 - 11    | 0.8 - 1.1   | 5.8 - 8.0 |
| <b>Three-way connector</b>                |           |             |           |
| Three-way connector to brake tube         | 15 - 18   | 1.5 - 1.8   | 11 - 13   |
| Three-way connector mounting bolt         | 5 - 7     | 0.5 - 0.7   | 3.6 - 5.1 |
| Brake hose connector                      | 17 - 20   | 1.7 - 2.0   | 12 - 14   |
| Brake tube flare nut                      | 15 - 18   | 1.5 - 1.8   | 11 - 13   |
| Wheel cylinder air bleeder                | 7 - 9     | 0.7 - 0.9   | 5.1 - 6.5 |
| <b>Front disc brake</b>                   |           |             |           |
| Baffle plate                              | 3.1 - 4.3 | 0.32 - 0.44 | 2.3 - 3.2 |
| Torque member fixing bolt                 | 72 - 97   | 7.3 - 9.9   | 53 - 72   |
| Torque member to cylinder body (Pin bolt) | 22 - 31   | 2.2 - 3.2   | 16 - 23   |
| Disc rotor to wheel hub                   | 59 - 69   | 6.0 - 7.0   | 43 - 51   |
| <b>Rear disc brake</b>                    |           |             |           |
| Baffle plate                              | 3.1 - 4.3 | 0.32 - 0.44 | 2.3 - 3.2 |
| Torque member fixing bolt                 | 38 - 52   | 3.9 - 5.3   | 28 - 38   |
| Torque member to cylinder body (Pin bolt) | 22 - 31   | 2.2 - 3.2   | 16 - 23   |
| <b>Parking brake</b>                      |           |             |           |
| <b>Center lever type</b>                  |           |             |           |
| Control lever to body                     | 16 - 21   | 1.6 - 2.1   | 12 - 15   |
| Adjuster lock nut                         | 3.1 - 4.3 | 0.32 - 0.44 | 2.3 - 3.2 |
| Front cable clamp to body                 | 8 - 11    | 0.8 - 1.1   | 5.8 - 8.0 |

# SPECIAL SERVICE TOOL

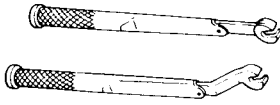
| Tool number<br>(Kent-Moore No.) | Tool name   |
|---------------------------------|---|
| GG94310000<br>( - )             | Flare nut torque wrench<br> |

