

HEATER & AIR CONDITIONER

SECTION **HA**

CONTENTS

GENERAL DESCRIPTION	HA- 2
AIR FLOW AND COMPONENT LAYOUT (Manual)	HA- 3
LOCATION OF VACUUM COMPONENTS	HA- 5
CONTROL	HA- 6
HEATER ELECTRICAL CIRCUIT	HA- 7
DESCRIPTION – Air conditioner (Manual)	HA- 9
DISCHARGING, EVACUATING, CHARGING AND CHECKING	HA- 12
A/C PERFORMANCE TEST (Manual)	HA- 18
PRECAUTIONS FOR REFRIGERANT CONNECTION	HA- 20
PIPING, COMPRESSOR MOUNTING AND F.I.C.D.	HA- 21
COMPRESSOR OIL – For MJS170	HA- 23
COMPRESSOR – Model MJS170	HA- 25
A/C ELECTRICAL CIRCUIT (Manual)	HA- 30
A/C ELECTRICAL COMPONENTS (Manual)	HA- 32
LOCATION OF A/C ELECTRICAL COMPONENTS (Manual)	HA- 34
TROUBLE DIAGNOSES (Manual)	HA- 35
DESCRIPTION – Air conditioner (Auto)	HA- 67
AIR FLOW AND COMPONENT LAYOUT (Auto)	HA- 87
LOCATION OF VACUUM COMPONENTS (Auto)	HA- 89
A/C PERFORMANCE TEST (Auto)	HA- 90
A/C PERFORMANCE TEST (Auto)/PIPING (Auto)	HA- 91
A/C ELECTRICAL CIRCUIT (Auto)	HA- 92
A/C ELECTRICAL COMPONENTS (Auto)	HA- 96
LOCATION OF A/C ELECTRICAL COMPONENTS (Auto)	HA- 97
SELF-DIAGNOSING SYSTEM OF TROUBLE (Auto)	HA-100
TROUBLE DIAGNOSES (Auto)	HA-103
SERVICE DATA AND SPECIFICATIONS (S.D.S.)	HA-135
SPECIAL SERVICE TOOLS	HA-138

GENERAL DESCRIPTION

Continuously Variable Air Flow Control

The fan control amplifier, which utilizes transistor circuits, continuously controls the air flow blown out by the blower, allowing for selection of the desired air flowrate. The fan control amplifier is housed in the blower motor unit. The heat-radiating plate of the amplifier is placed in the stream of the air flow to effectively cool the transistors.

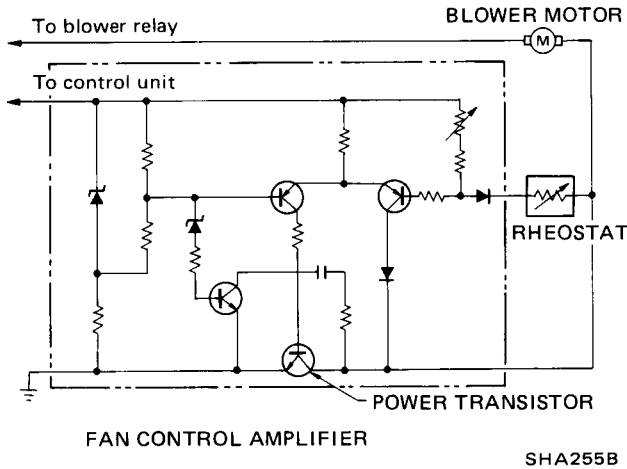

Device for Distributing Cool Air to the Feet during "FACE MODE"

A vacuum actuator is used in the cool-air distribution device to remove the hot air directed to the floor area and distribute the optimum air temperature to the driver's compartment. When the vacuum switch is turned "ON", part of the outside air (or: part of the cool air on models equipped with air conditioning systems) taken in the vehicle is bypassed to the shower duct on the driver's side through the operation of the actuator.

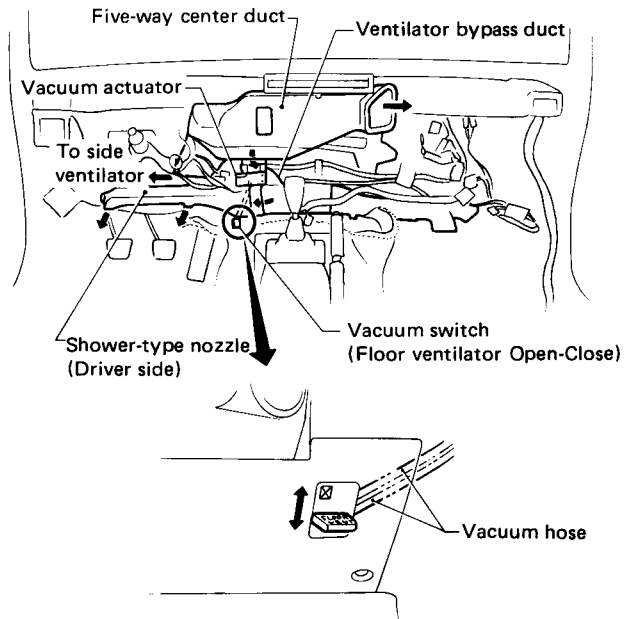

AIR FLOW AND COMPONENT LAYOUT (Manual)

Air Flow

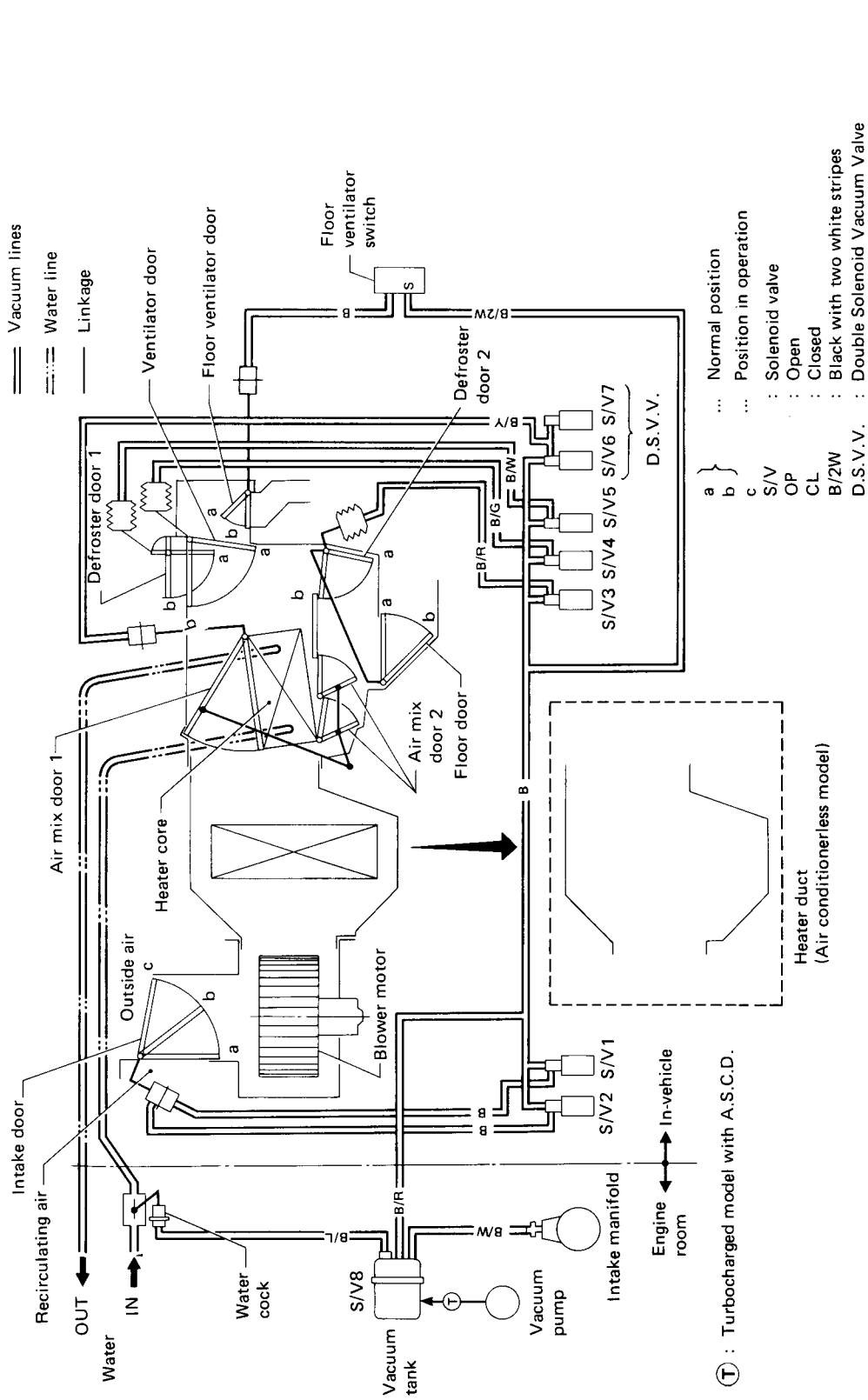

FLOOR VENTILATOR SWITCH	PULL UP	a
DOOR SWITCH	PRESS DOWN	b
FLOOR VENT. DOOR		

WATER COCK CONTROL	OPEN	CL
OPERATION OF SOLENOID VALVE	S/V 8	CL. OP.

INTAKE CONTROL	RECIRC.	OUTSIDE
	c	b
INTAKE DOOR	S/V 1	OP. CL.
OPERATION OF SOLENOID VALVE	S/V 2	OP. CL.

AIR MIX DOOR CONTROL	HOT side	HOLD	COLD side
	S/V 6	CL. CL.	OP. CL.
OPERATION OF SOLENOID VALVE	S/V 7	OP. CL.	CL. CL.

MODE	FACE	B/L	FOOT	DEMIST	DEF
	DEF. DOOR 1	b	b	a	a
	VENT. DOOR	b	b	a	a
DOOR POSITION	FLOOR DOOR	a	b	b	a
	DEF. DOOR 2	a	b	b	a
OPERATION OF SOLENOID VALVE	S/V 3	CL.	OP.	OP.	CL.
	S/V 4	OP.	OP.	CL.	CL.
	S/V 5	OP.	OP.	OP.	CL.

AIR FLOW AND COMPONENT LAYOUT (Manual)

Component Layout

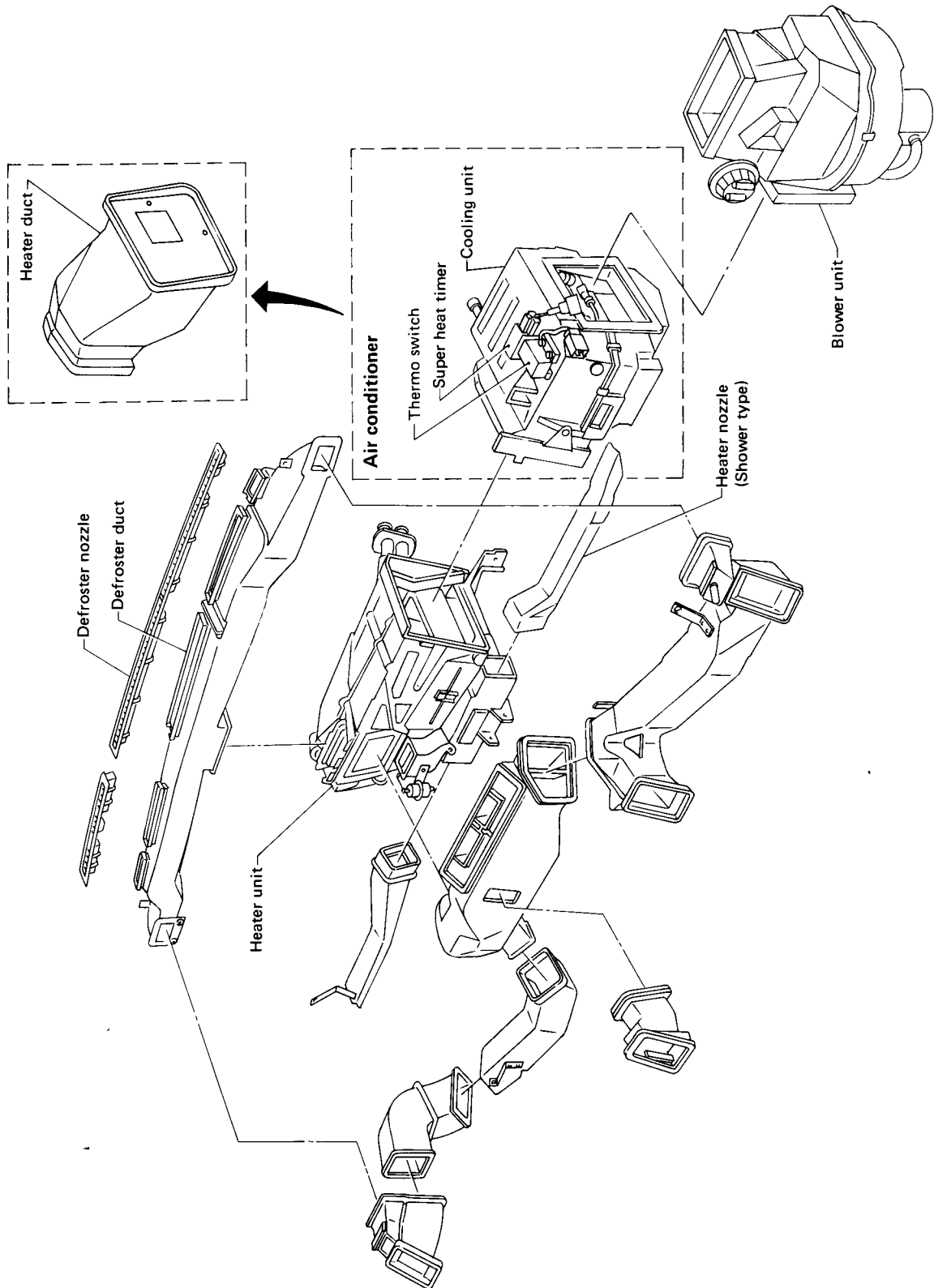

SHA232B

LOCATION OF VACUUM COMPONENTS

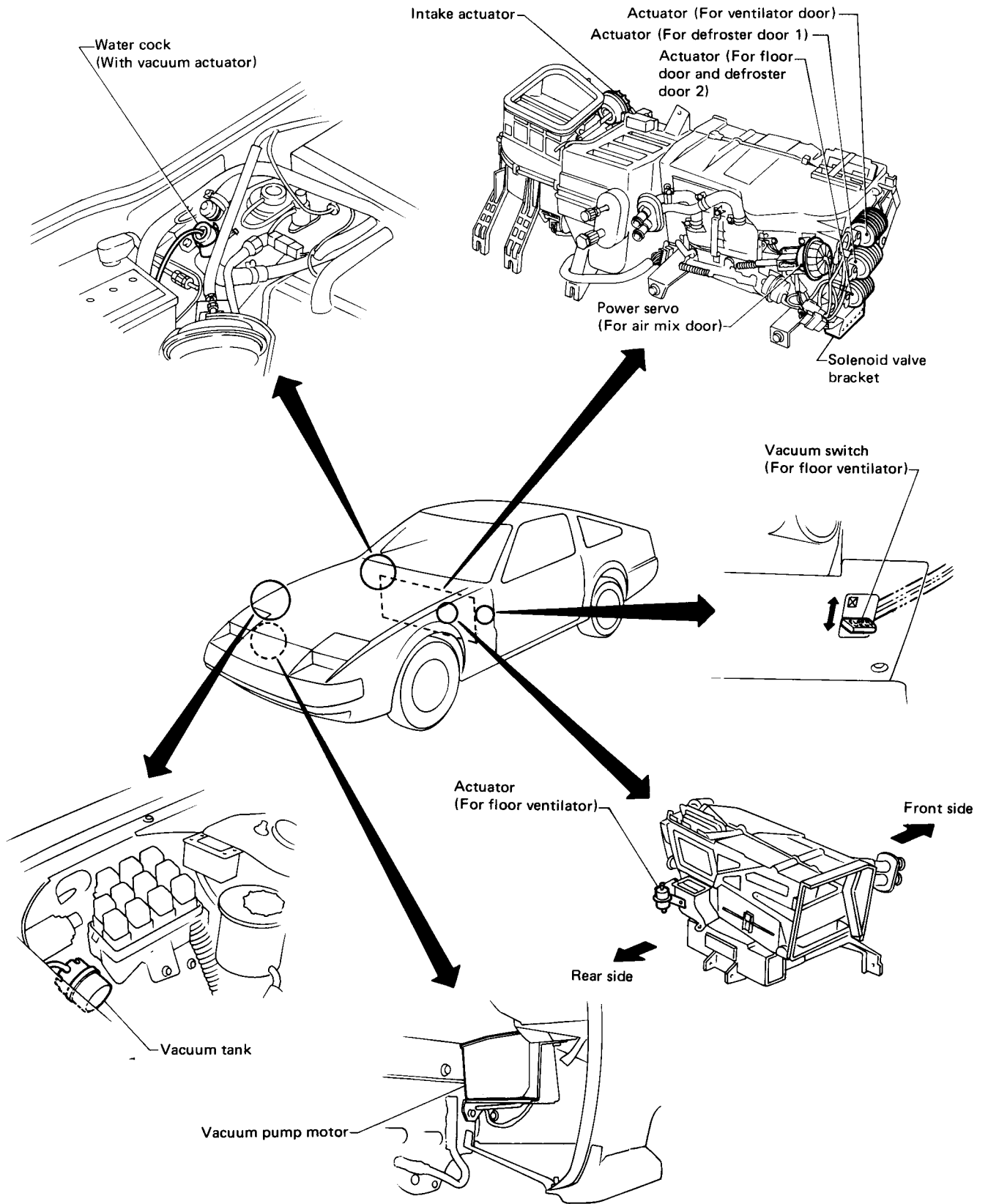

SHA233B

CONTROL

Heater and Air Conditioner Control Removal

PROCEDURES

Remove each screw in the number order shown in the following illustration.

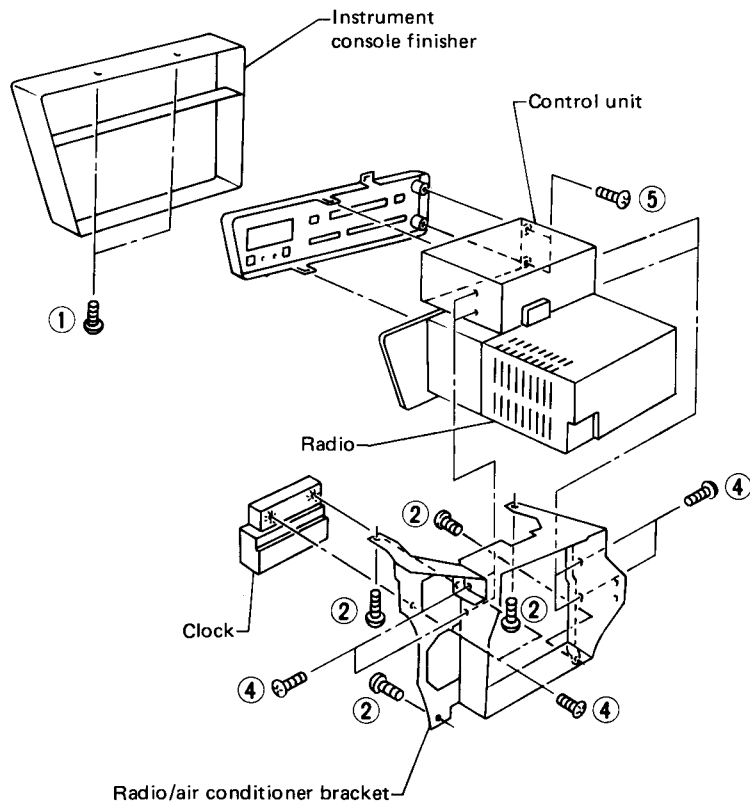

SHA234B

HEATER ELECTRICAL CIRCUIT

Schematic

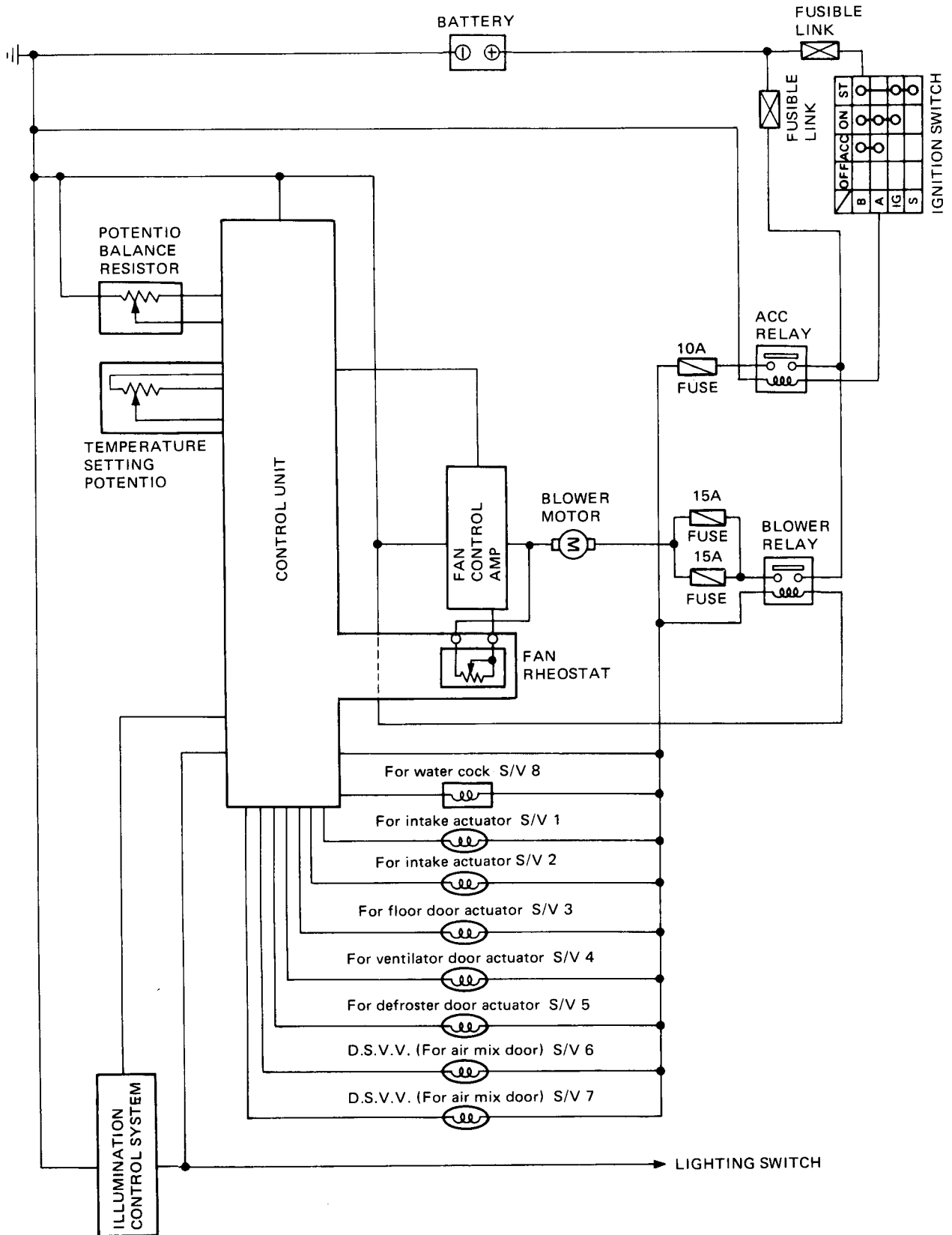

SHA417B

HEATER ELECTRICAL CIRCUIT

Wiring Diagram

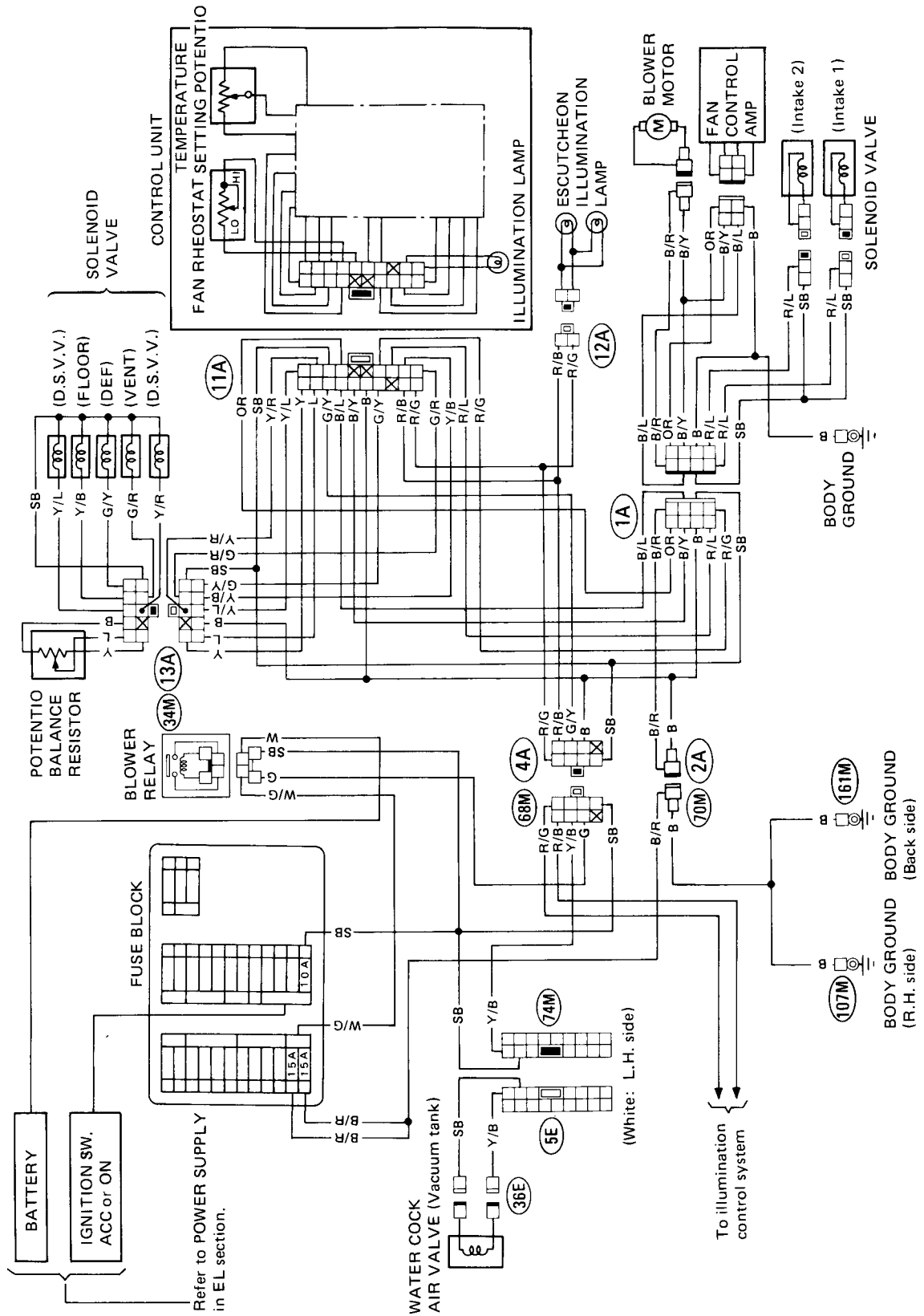

SHA517B

DESCRIPTION—Air Conditioner (Manual)

Refrigeration Cycle

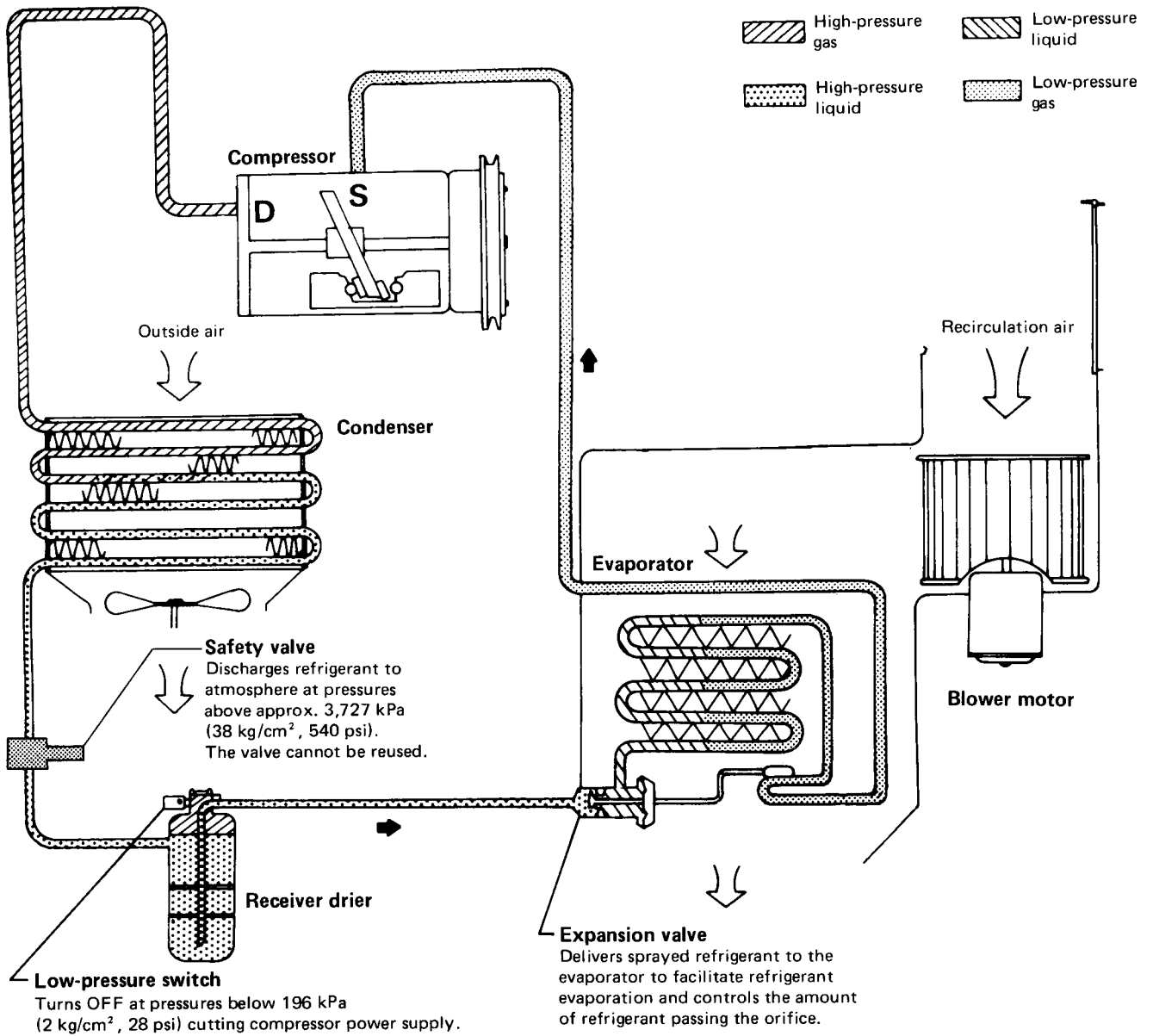

SHA606B

DESCRIPTION—Air Conditioner (Manual)

Refrigerant Leak Warning System

The refrigerant leak warning system, used in conjunction with the low-pressure switch, protects the cooler cycle from damage due to continued operation of the air conditioning system when there is a shortage of refrigerant. It also indicates when to replenish the refrigerant.

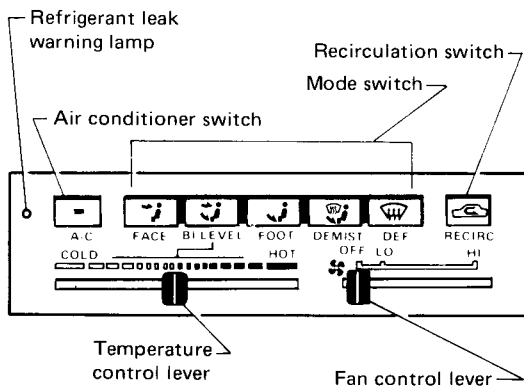

SHA227B

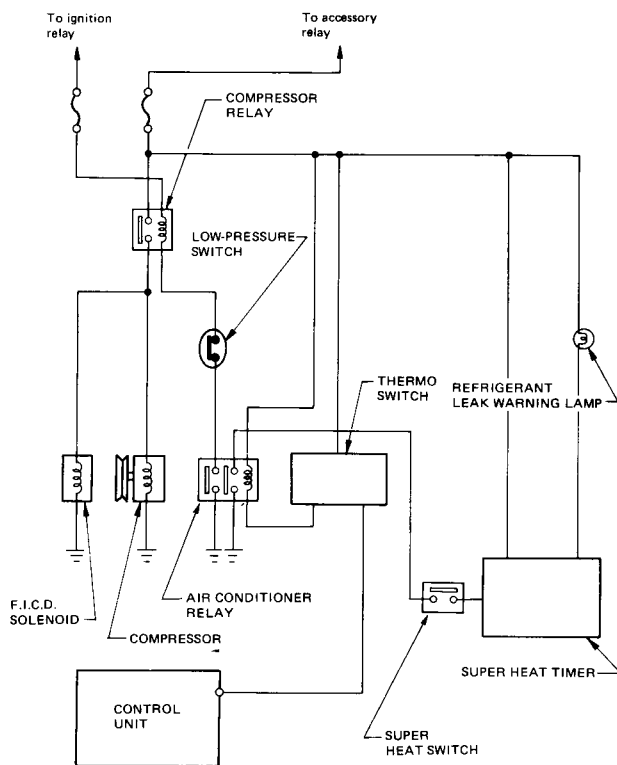

SHA228B

When the refrigerant in the cooler cycle is insufficient, it vaporizes quickly inside the evaporator. As a result, the "super heat" of the refrigerant at the outlet of the evaporator increases. If it exceeds the specified level [Approximately 45°C (81°F)], the super heat switch turns on, allowing the current to flow through the timer. If current continues to flow through the timer for the specified length of time, the timer activates to close the contacts which turn on the warning lamp.

Leak warning lamp check

Conduct a continuity test in the leak warning lamp circuit.

- 1) Turn ignition switch "ON" (with engine off) to make sure warning lamp illuminates.
- 2) Start engine. Warning lamp should go out if the amount of refrigerant is sufficient.

EXPLANATION OF SUPER HEAT

When a liquid under constant pressure inside a cylinder is heated, it apparently changes in three different states. The relationship between the temperature of the liquid (refrigerant) and its volume, which uses the pressure as a parameter, is shown in the graph below.

- 1) The temperature of the liquid rises along the saturated liquid line (a → b or a' → b').
- 2) When the temperature of the liquid reaches a certain level, evaporating bubbles quickly appear. This mixture of liquid and vapor continues to take place, during which the temperature remains constant until the last droplet of liquid vaporizes. Points c and c' where the entire liquid vaporizes, are located on the saturated vapor line (b → c or b' → c').
- 3) When the liquid is further heated, the temperature of the vapor rises again and its volume also increases. The volume will continue to increase as the temperature is increased.

We call this vapor "super heated vapor" (c → d or c' → d').

The line between points c and c' is called the "saturated vapor line."

DESCRIPTION—Air Conditioner (Manual)

Refrigerant Leak Warning System (Cont'd)

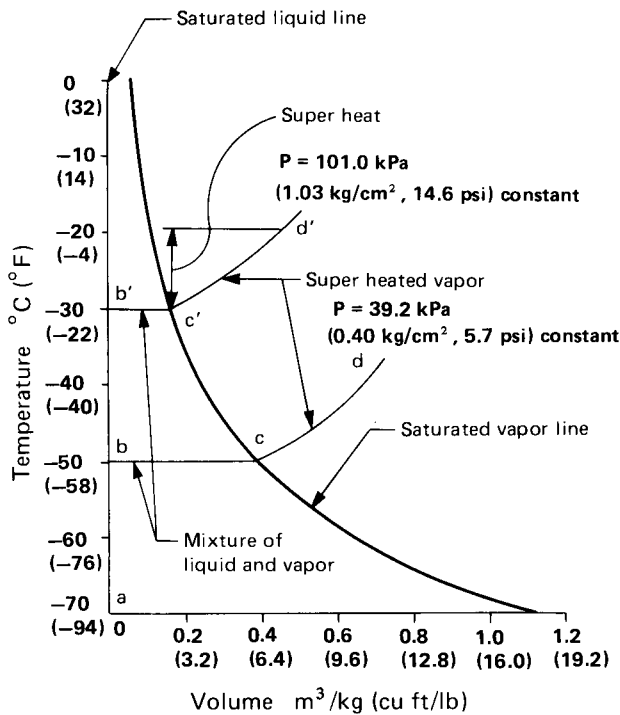

Relation between temperature and volume
(Refrigerant R-12)

SHA239B

Definition

The super heat is the difference between the temperature of an optional super heated vapor point and the saturated temperature point (which is located on the saturated vapor line) under the same pressure as for the former point.

SUPER HEAT SWITCH

The super heat switch, placed, in the refrigerant line at the outlet of the evaporator, consists of a diaphragm, temperature sensor, moving contact (A) and fixed contact (B). The diaphragm detects the refrigerant line pressure and the temperature sensor senses the refrigerant line temperature.

When the temperature in the refrigerant line increases, the gas charged inside the temperature sensor expands. This causes a force to move the diaphragm upward against the refrigerant line pressure. When the difference between the saturated temperature and the detected temperature in relation to the detected pressure reaches a specified condition, the adjusting screw is pushed up by the diaphragm. This then causes moving contact point (A) to move down so that the super heat switch turns "ON".

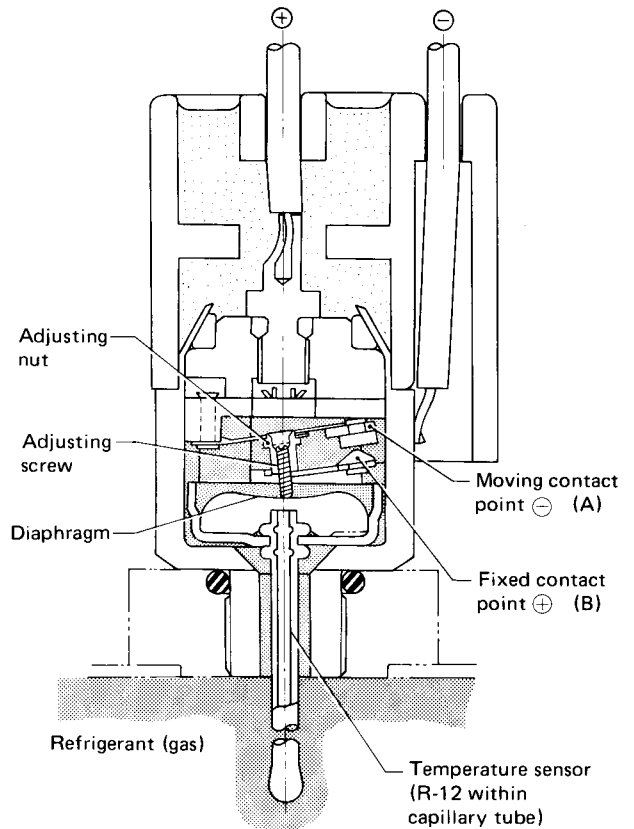

SHA229B

SUPER HEAT TIMER

During rapid acceleration, the "super heat" increases momentarily and returns to its original level quickly even when the amount of the refrigerant is normal. Because of this, a timer, used in the warning system, detects an increase in "super heat" only when the amount of refrigerant is low, thereby preventing erroneous alarms.

DISCHARGING, EVACUATING, CHARGING AND CHECKING

Precautions

WARNING:

- Always be careful that refrigerant does not come in contact with your skin.
- Always wear eye protection when working around the system.
- Keep refrigerant containers stored below 50° C (122° F) and never drop it from a high place.
- Work in well-ventilated area because refrigerant gas evaporates quickly and breathing may become difficult due to the lack of oxygen.
- Keep refrigerant away from open flames because poisonous gas will be produced if it burns.
- Do not use steam to clean surface of condenser or evaporator. Be sure to use cold water or compressed air.
- Compressed air must never be used to clean a dirty line. Clean with refrigerant gas.
- Do not use manifold gauge whose press point shape is different. Otherwise, insufficient evacuating may occur.

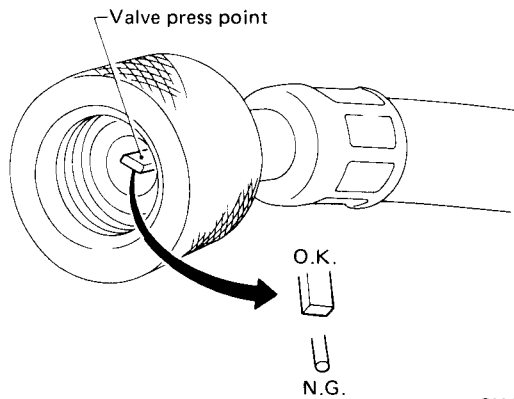

- Do not over-tighten service valve cap.
- Do not allow refrigerant to rush out. Otherwise, compressor oil will be discharged along with refrigerant.

Discharging

Slowly open the valves to discharge only refrigerant. If they are opened quickly, compressor oil will also be discharged.

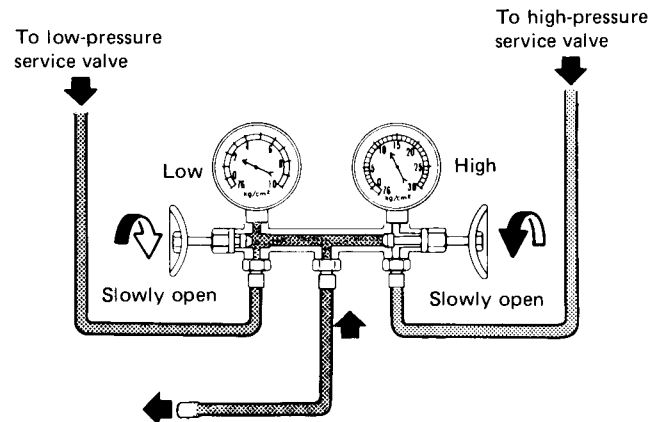

SHA240B

DISCHARGING, EVACUATING, CHARGING AND CHECKING

Evacuating The System

1. Start pump, then open both valves and run pump for about 20 minutes.

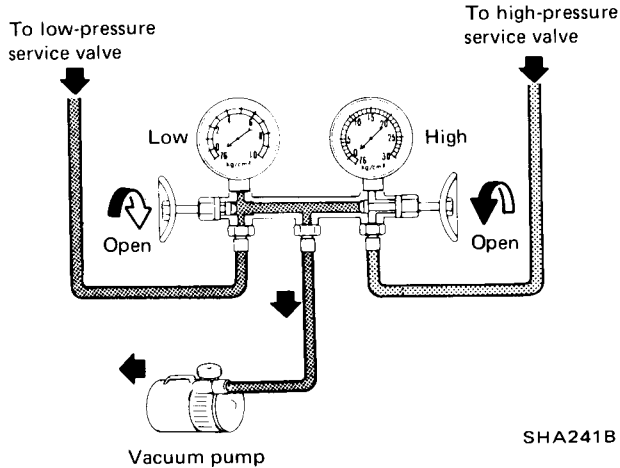

2. When low gauge has reached approx. 101.3 kPa (760 mmHg, 29.92 inHg), completely close both valves of gauge and stop vacuum pump. Let it stand for 5 to 10 minutes in this state and confirm that the reading does not rise.
 - a. The low-pressure gauge reads lower by 3.3 kPa (25 mmHg, 0.98 inHg) per 300 m (1,000 ft) elevation. Perform evacuation according to the following table.

Elevation m (ft)	Vacuum of system* kPa (mmHg, inHg)
0 (0)	101.3 (760, 29.92)
300 (1,000)	98.0 (735, 28.94)
600 (2,000)	94.6 (710, 27.95)
900 (3,000)	91.3 (685, 26.97)

*: Values show reading of the low-pressure gauge.

- b. The rate of ascension of the low-pressure gauge should be less than 3.3 kPa (25 mmHg, 0.98 inHg) in five minutes.

Charging

1. Evacuate refrigerant system.
2. Close manifold gauge valves securely and disconnect charging hose from vacuum pump.
3. Purge air from center charging hose.
 - 1) Connect center charging hose to refrigerant can through can top.
 - 2) Break seal of refrigerant can and purge air.

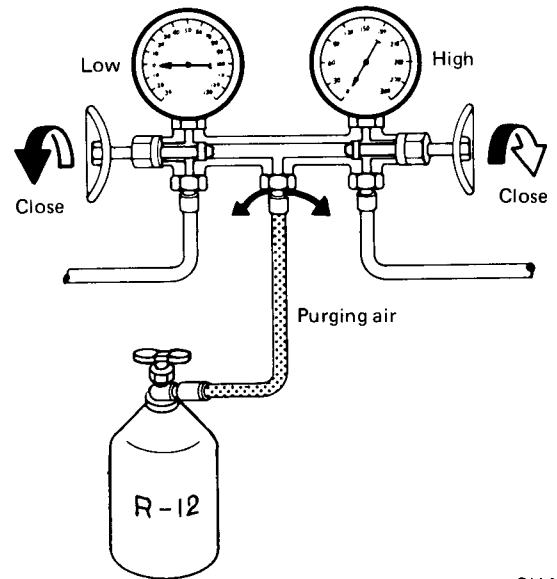

4. Charge refrigerant into system.

WARNING:

Ensure that engine is off.

- 1) Open high- and low-pressure valves of manifold gauge and charge refrigerant into system.

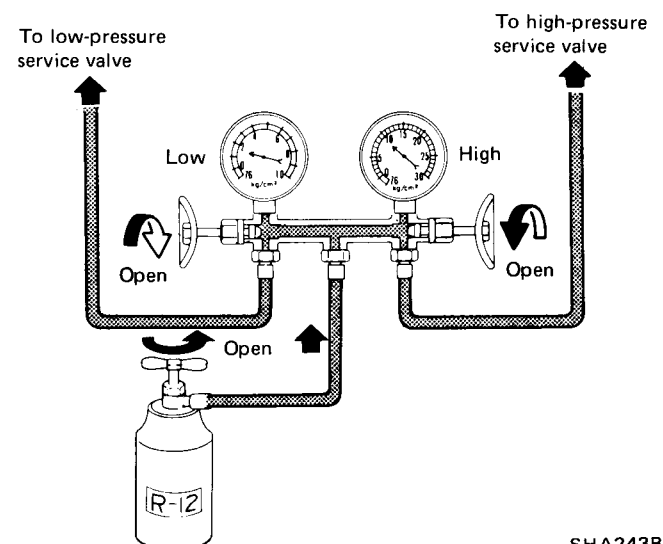

DISCHARGING, EVACUATING, CHARGING AND CHECKING

Charging (Cont'd)

2) Quick charging

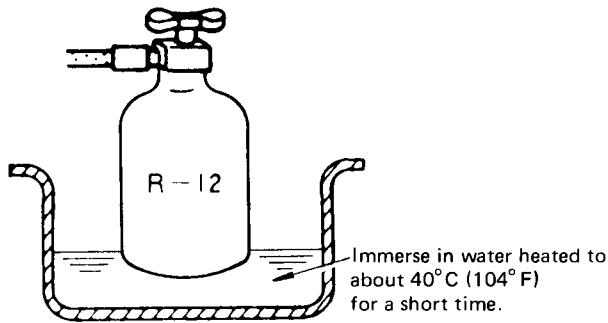

AC184A

CAUTION:

If charging liquefied refrigerant into the system with the can turned upside down to reduce charging time, charge it only through high pressure (discharge) service valve. After charging, the compressor should always be turned several times manually.

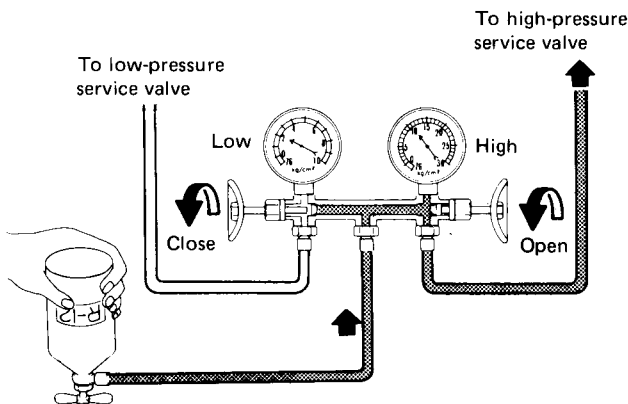

SHA244B

- When refrigerant charging speed slows down, charge it while running the compressor for ease of charging.

WARNING:

Never charge refrigerant through high pressure side (discharge side) of system since this will force refrigerant back into refrigerant can and can may explode.

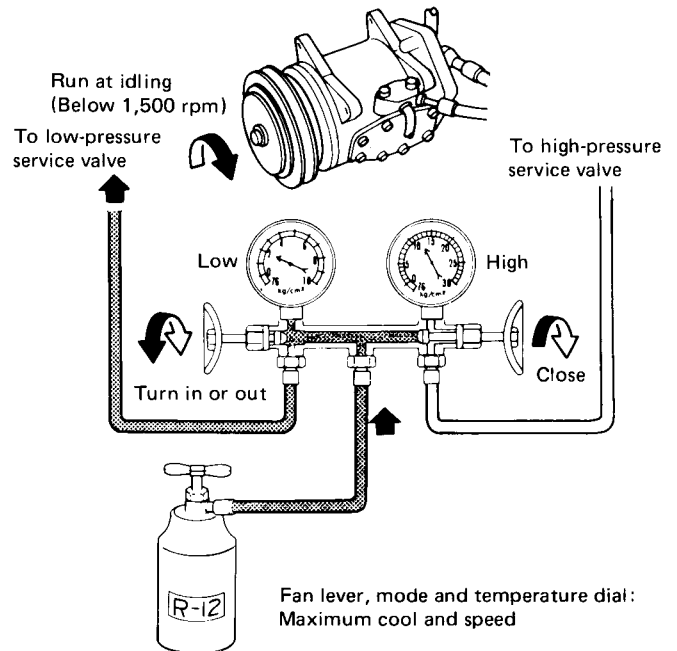

SHA245B

- Charge refrigerant while controlling low-pressure gauge reading at 275 kPa (2.8 kg/cm², 40 psi) or less by turning in or out low-pressure valve of manifold gauge.

- Be sure to purge air from charging hose when replacing can with a new one.
- Charge the specified amount of refrigerant into system by weighing charged refrigerant with scale. Overcharging will cause discharge pressure to rise.

Refrigerant amount:

MJS170

0.9 - 1.1 kg (2.0 - 2.4 lb)

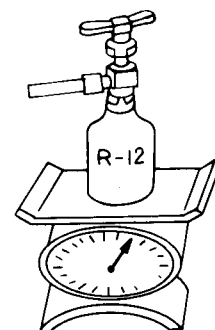

SHA900A

DISCHARGING, EVACUATING, CHARGING AND CHECKING

Charging (Cont'd)

The state of the bubbles in sight glass should only be used for checking whether the amount of charged refrigerant is small or not. The amount of charged refrigerant can be correctly judged by means of discharge pressure.

8. After charging, be sure to install valve cap on service valve.
9. Confirm that there are no leaks in system by checking with a leak detector.

DISCHARGING, EVACUATING, CHARGING AND CHECKING

Checking Refrigerant Level

CONDITION

- Door window: Open
- A/C switch: ON

- TEMP. lever position: Max. COLD
- FAN lever position: Maximum speed
- Check sight glass after a lapse of about five minutes.

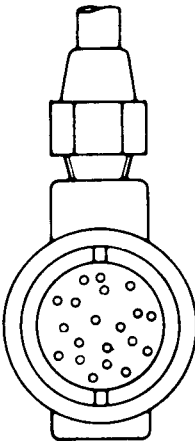
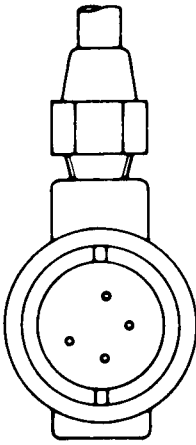
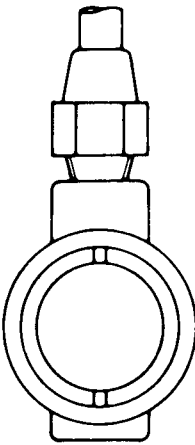
Check item	Amount of refrigerant			
	Almost no refrigerant	Insufficient	Suitable	Too much refrigerant
Temperature of high pressure and low pressure lines.	Almost no difference between high pressure and low pressure side temperature.	High pressure side is warm and low pressure side is fairly cold.	High pressure side is hot and low pressure side is cold.	High pressure side is abnormally hot.
State in sight glass.	Bubbles flow continuously. Bubbles will disappear and something like mist will flow when refrigerant is nearly gone.	The bubbles are seen at intervals of 1 - 2 seconds.	Almost transparent. Bubbles may appear when engine speed is raised and lowered. No clear difference exists between these two conditions.	No bubbles can be seen.
	 AC256	 AC257	 AC258	
Pressure of system.	High pressure side is abnormally low.	Both pressure on high and low pressure sides are slightly low.	Both pressures on high and low pressure sides are normal.	Both pressures on high and low pressure sides are abnormally high.
Repair.	Stop compressor immediately and conduct an overall check.	Check for gas leakage, repair as required, replenish and charge system.		Discharge refrigerant from service valve of low pressure side.

a. The bubbles seen through the sight glass are influenced by the ambient temperature. Since the bubbles are hard to show up in comparatively low temperatures below 20°C (68°F), it is possible that a slightly larger amount of refrigerant would be filled, if supplied according to the sight glass. Be sure to recheck the amount when it exceeds 20°C (68°F). In

higher temperature the bubbles are easy to show up.

b. When the screen in the receiver drier is clogged, the bubbles will appear even if the amount of refrigerant is normal. In this case, the outlet side pipe of the receiver drier becomes considerably cold.

DISCHARGING, EVACUATING, CHARGING AND CHECKING

Checking Refrigerant Leaks

ELECTRIC LEAK-DETECTOR

The leak detector is a delicate device that detects small amounts of halogen.

In order to use the device properly, read the manuals put out by each maker and perform the specified maintenance and inspections.

Nominal sensitivity:
15 - 25 g (0.53 - 0.88 oz)/year

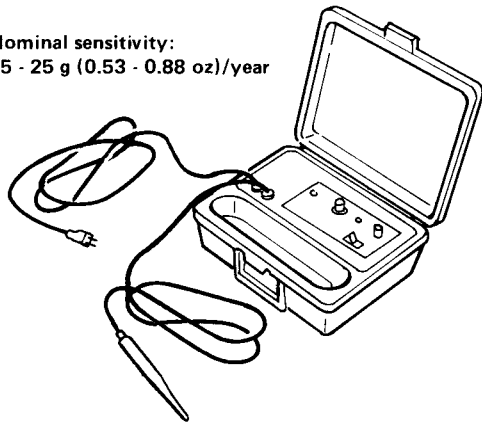

SHA733A

GENERAL PRECAUTIONS FOR HANDLING LEAK DETECTOR

1. Each fitting must be checked around its entire periphery.

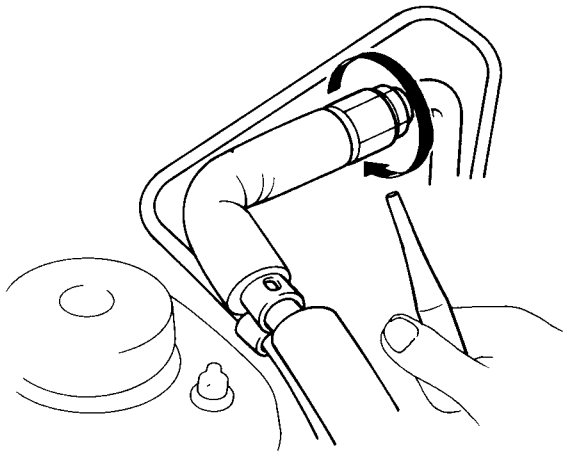

SHA734A

2. Move probe close to and 3 mm (0.12 in) away from the point to be checked.

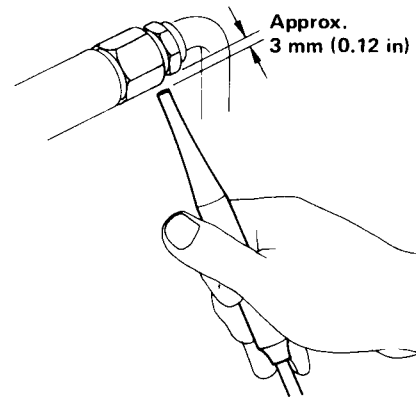

SHA735A

3. The moving speed of the probe must be maintained at less than 3 cm (1.2 in)/sec.

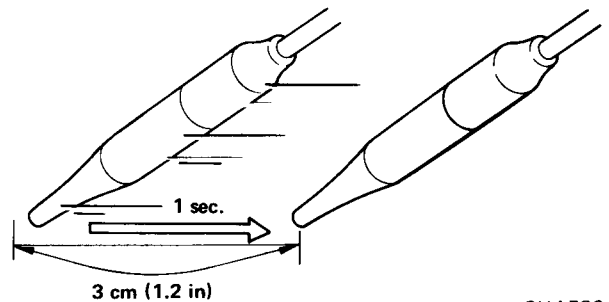

SHA736A

MEASUREMENT STANDARD

If any reaction is noted using a detector having a nominal sensitivity of 15 to 25 g (0.53 to 0.88 oz)/year, that portion checked be found as leaking, and therefore must be repaired.

- Oil deposited during assembling must be wiped off before inspection.
- If any trace of oil is noted at and around connection fittings, it is a sure indication that refrigerant is leaking.
- When the gas leaking point is found, disconnect that line and replace the O-ring. Check seal seat for fit for further use and then tighten connections to the specified torque.
- Do not overtighten.

A/C PERFORMANCE TEST (Manual)

Performance Chart

TEST CONDITION

Testing must be performed as follows:

Vehicle location:	Indoors or in the shade (in a well ventilated place)
Doors:	Closed
Door window:	Open
Hood:	Open
TEMP. lever position:	Max. COLD
Mode switch position:	 (Face)
Recirculation switch position:	RECIRC. ON
FAN speed:	MAX. HI
Engine speed:	1,500 rpm
Time required before starting testing after air conditioner starts operating:	More than 10 minutes

TEST READING

Recirculating-to-discharge air temperature table

Inside air (Recirculating air) at blower assembly inlet		Discharge air temperature at center ventilator °C (°F)
Relative humidity %	At temperature °C (°F)	
50 - 60	20 (68)	4.5 - 5.0 (40 - 41)
	25 (77)	8.6 - 9.5 (47 - 49)
	30 (86)	12.7 - 14.1 (55 - 57)
	35 (95)	16.7 - 18.6 (62 - 65)
	40 (104)	20.8 - 23.1 (69 - 74)
60 - 70	20 (68)	5.0 - 5.5 (41 - 42)
	25 (77)	9.5 - 10.5 (49 - 51)
	30 (86)	14.1 - 15.5 (57 - 60)
	35 (95)	18.6 - 20.5 (65 - 69)
	40 (104)	23.1 - 25.4 (74 - 78)

A/C PERFORMANCE TEST (Manual)

Performance Chart (Cont'd)

Ambient air temperature to compressor pressure table

Ambient air		High pressure (Discharge side) kPa (kg/cm ² , psi)	Low pressure (Suction side) kPa (kg/cm ² , psi)
Relative humidity %	Air temperature °C (°F)		
50 - 70	20 (68)	853 - 1,049 (8.7 - 10.7, 124 - 152)	59 - 78 (0.6 - 0.8, 9 - 11)
	25 (77)	1,040 - 1,275 (10.6 - 13.0, 151 - 185)	88 - 108 (0.9 - 1.1, 13 - 16)
	30 (86)	1,216 - 1,491 (12.4 - 15.2, 176 - 216)	108 - 137 (1.1 - 1.4, 16 - 20)
	35 (95)	1,393 - 1,706 (14.2 - 17.4, 202 - 247)	137 - 167 (1.4 - 1.7, 20 - 24)
	40 (104)	1,579 - 1,932 (16.1 - 19.7, 229 - 280)	157 - 196 (1.6 - 2.0, 23 - 28)

- a. The pressure will change in the following manner with changes in conditions:
- When blower speed is low, discharge pressure will drop.
 - When the relative humidity of intake air is low, discharge pressure will drop.

- b. The temperature will change in the following manner with changes in conditions:
When the ambient air temperature is low, the outlet air temperature will become low.

PRECAUTIONS FOR REFRIGERANT CONNECTION

WARNING:

Gradually loosen discharge side hose fitting, and remove it after remaining pressure has been released.

When replacing or cleaning refrigerant cycle components, observe the following.

- Do not leave compressor on its side or upside down for more than 10 minutes, as compressor oil will enter low pressure chamber.
- When connecting tubes, be sure to use a torque wrench.

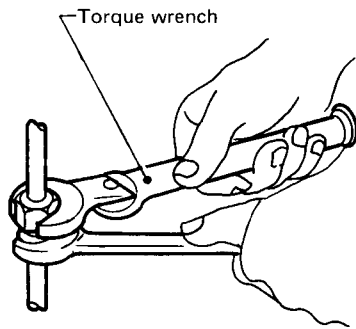

SHA896A

- After disconnecting tubes, plug all openings immediately to prevent entrance of dirt and moisture.

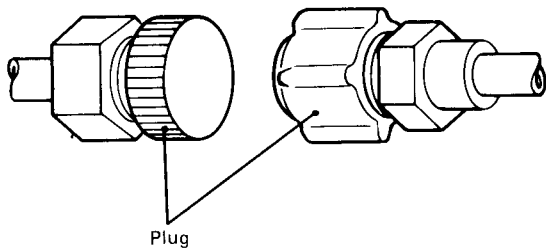

SHA058

- Do not reuse used O-ring.
- When connecting tube, apply compressor oil to portions shown in illustration. Be careful not to apply oil to threaded portion.
- O-ring must be closely attached to inflated portion of tube.

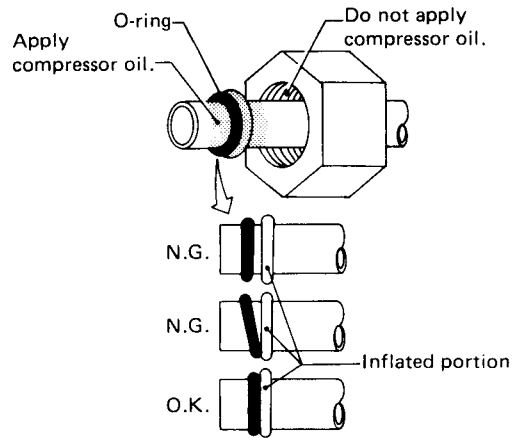

SHA897A

- After inserting tube into union until O-ring is no more visible, tighten nut to specified torque.

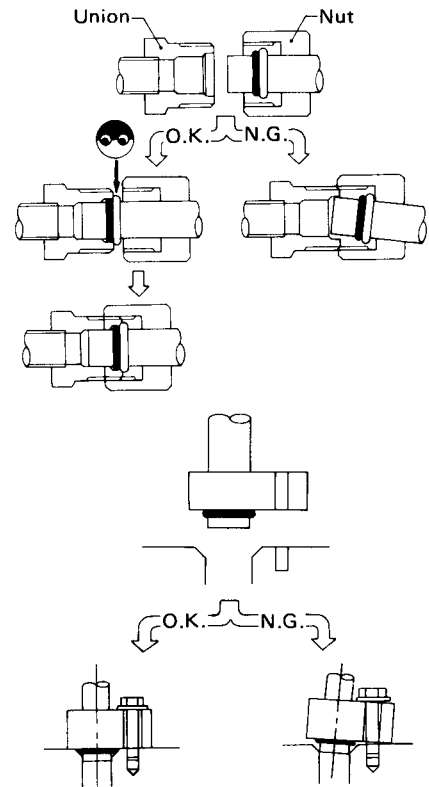

SHA898A

- After connecting line, conduct leak test and make sure that there is no leak from connections. When the gas leaking point is found, disconnect that line and replace the O-ring. Check fit for further use and then tighten connections to seal seat for the specified torque.

PIPING, COMPRESSOR MOUNTING AND F.I.C.D.

Refrigerant Lines

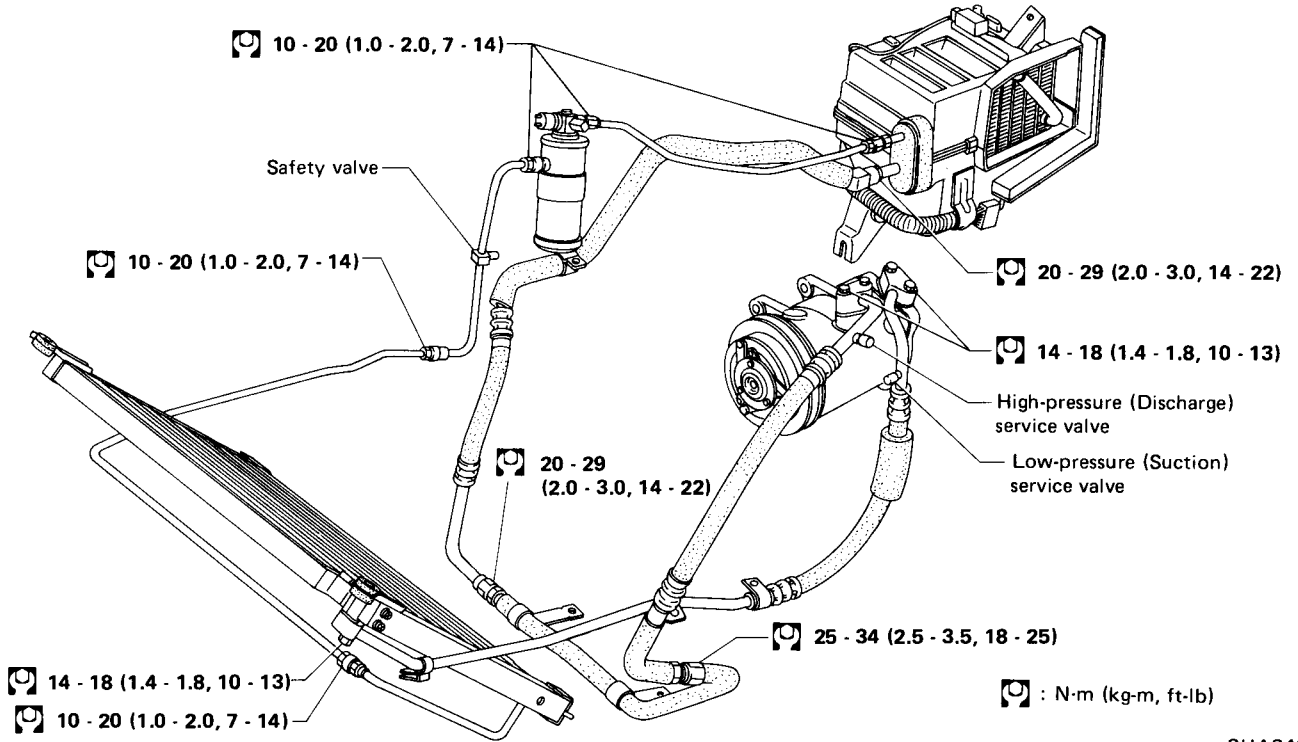

SHA246B

Compressor Mounting

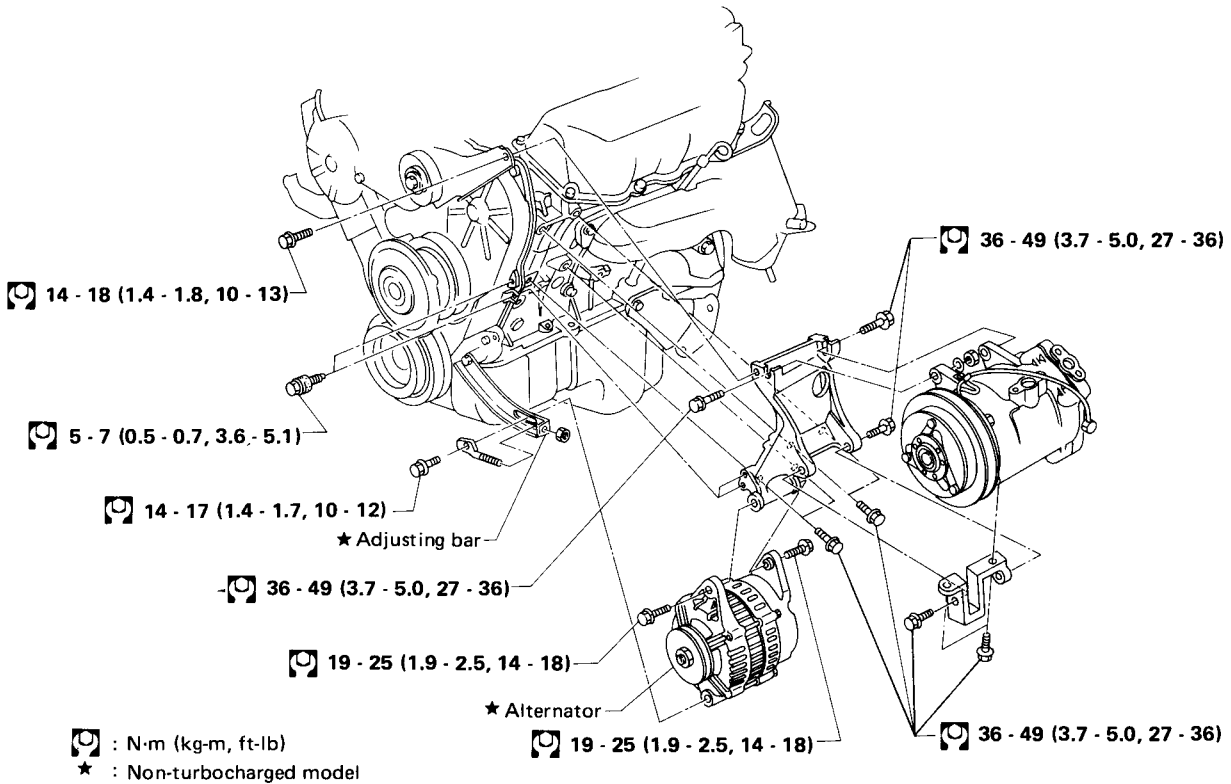

SHA247B

PIPING, COMPRESSOR MOUNTING AND F.I.C.D.

Idle Speed Adjusting and Checking

FAST IDLE CONTROL DEVICE (F.I.C.D.)

1. Run engine until it reaches operating temperature.
2. With air conditioning system OFF (when compressor is not operating), make sure that engine is at correct idle speed.
3. With air conditioning system ON (Recirculation switch at "RECIRC" position, fan control lever at "HI" position), make sure that compressor and F.I.C.D. solenoid valve are functioning properly.
4. For non-turbocharged model, set idle speed at the specified value.
For turbocharged model, make sure that idle speed is at the specified value. **(Non-adjustable)**

Non-turbocharged model

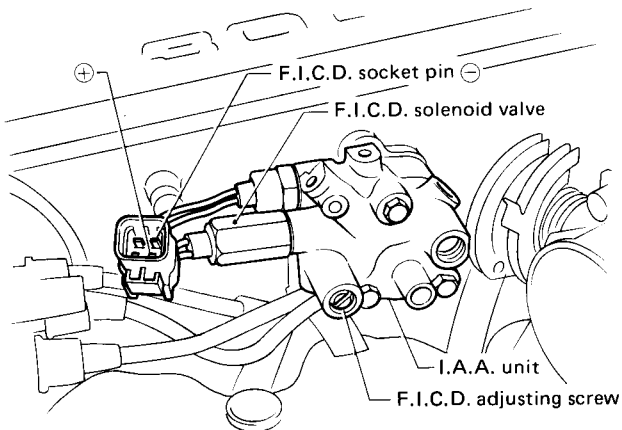

SHA223B

Turbocharged model

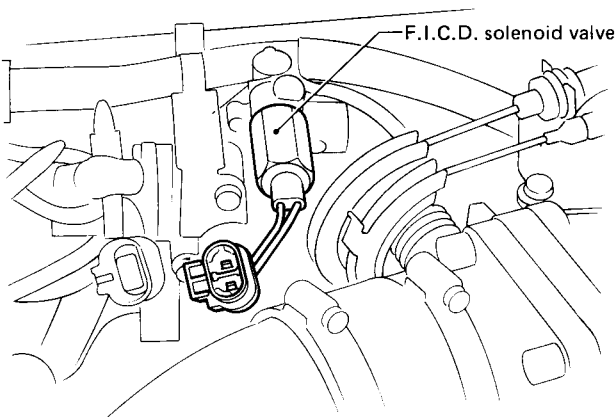

SHA248B

ENGINE IDLING SPEED

Transmission		Non-turbocharged model	Turbocharged model
When A/C is OFF			
Refer to MA section.			
When A/C is ON			
M/T	rpm	900 - 1,000	950 - 1,050
A/T	rpm	900 - 1,000 ± at "D" range	950 - 1,050 ± at "D" range

COMPRESSOR OIL—For MJS170

Checking and Adjusting

The oil used to lubricate the compressor is circulating with the refrigerant.

Whenever replacing any component of the system of a large amount of gas leakage occurs, add oil to maintain the original amount of oil.

Total amount of oil in the system:

150 ml (5.1 US fl oz, 5.3 Imp fl oz)

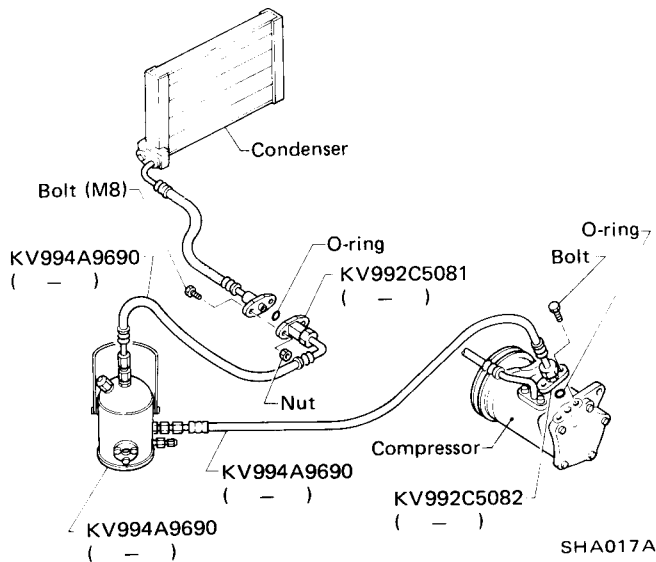

1. Connect oil separator KV994A9690 between compressor discharge side and condenser.
2. Evacuate and charge the system.
3. Operate compressor at engine idling with air conditioner set for maximum cooling and high fan speed.
4. Stop compressor operation after 10 minutes.

Never allow engine speed to exceed idling speed.

CAUTION:

Do not continue compressor operation for more than 10 minutes.

5. Disconnect oil separator and connect refrigerant line to original positions.
6. Disconnect low flexible hose from compressor suction valve.
7. Add new oil from compressor suction port.

Amount of oil to be added:

120 ml (4.1 US fl oz, 4.2 Imp fl oz)

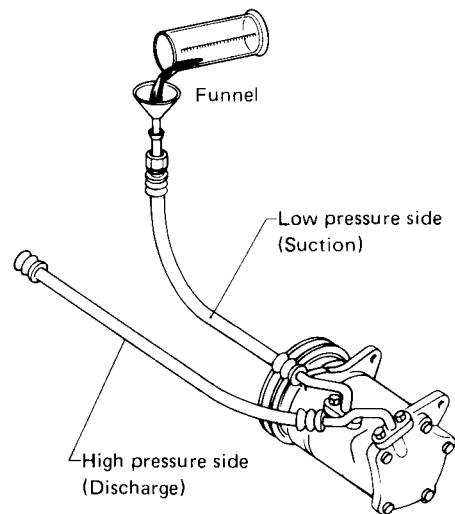

- **Oil remains unremoved in the system about 30 ml (1.0 US fl oz, 1.1 Imp fl oz).**
8. After adding oil, rotate compressor clutch by hand 5 to 10 turns.
 9. Connect refrigerant line and evacuate and charge system.
 10. Conduct leak test and performance test.
 11. Gradually loosen drain cap of oil separator to release residual pressure. Remove cap and drain oil.
 12. To prevent formation of rust and intrusion of moisture or dust, perform the following before placing oil separator kit into storage.
 - 1) Cap each opening of flexible hose and double union securely.
 - 2) Cap oil separator, evacuate it from service valve, and charge refrigerant.

COMPRESSOR OIL—For MJS170

Checking and Adjusting (Cont'd)

IF OIL SEPARATOR IS NOT AVAILABLE

Add oil in accordance with the table below.

Condition		Amount of oil to be added mℓ (US fl oz, Imp fl oz)
Replacement of compressor		1. Remove all oil from new and old compressors.* 2. Charge new compressor with the same amount of oil as was in the old compressor.
Replacement of evaporator		80 (2.7, 2.8)
Replacement of receiver dryer (liquid tank)		Oil need not be added.
Replacement of condenser	There is no sign of oil leakage from condenser.	Oil need not be added.
	There are evidences of a large amount of oil leakage from condenser.	60 (2.0, 2.1)
Replacement of flexible hose or pipe	There is no sign of oil leakage.	Oil need not be added.
	There are evidences of a large amount of oil leakage.	70 (2.4, 2.5)
Gas leakage	There is no sign of oil leakage.	Oil need not be added.
	There are evidences of a large amount of oil leakage.	70 (2.4, 2.5)

* Remove compressor oil as follows.

1. With the compressor upside down, completely drain the oil through the suction port (from the embossed letter "s" mark side).

2. When the oil stops flowing out, rotate the clutch hub two or three times to completely drain the oil.

COMPRESSOR—Model MJS170

*: Do not reuse.

When installing, apply compressor oil sparingly to contacting surfaces of shaft seal set and O-ring.

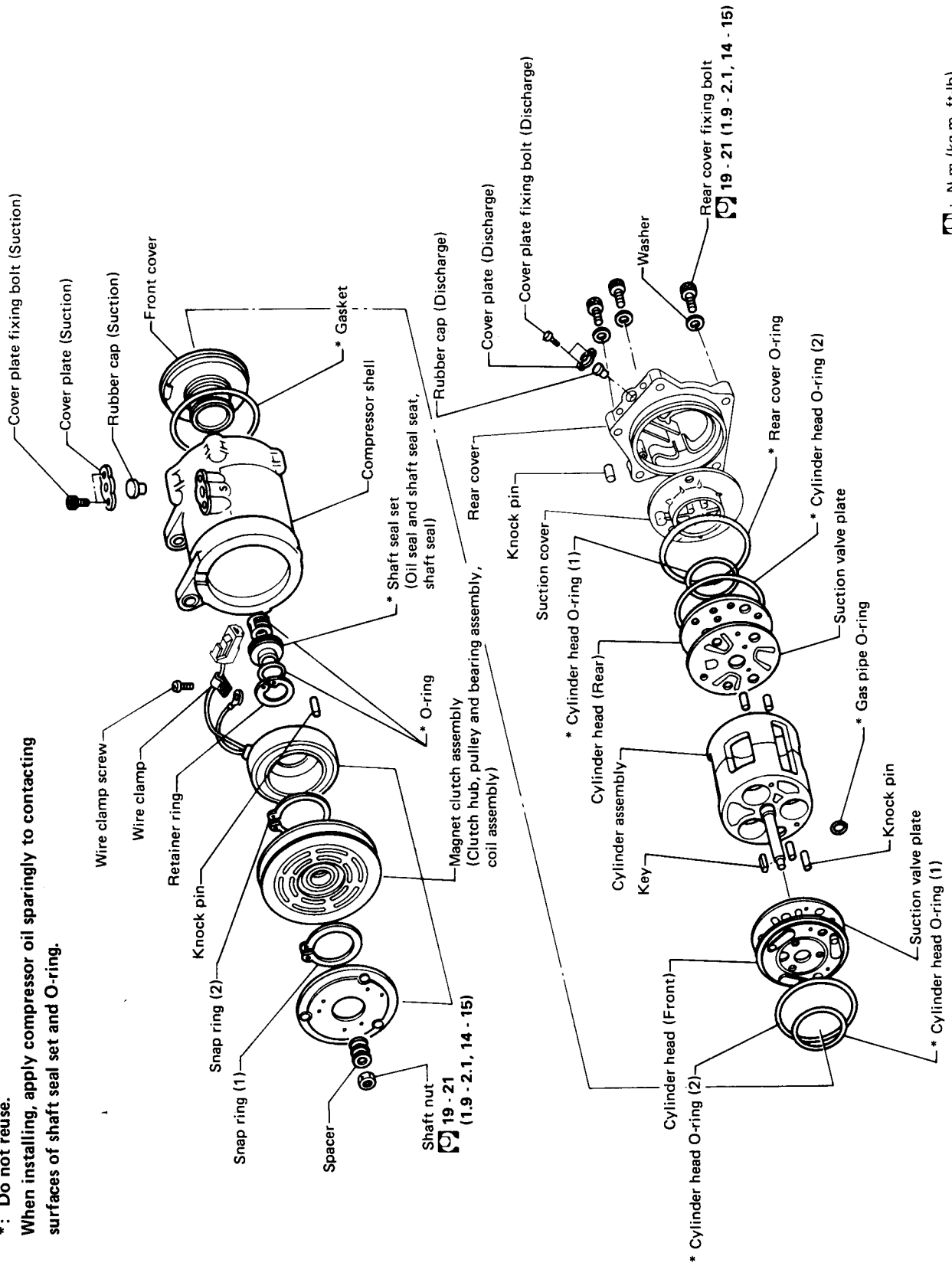

☐ : N·m (kg·m, ft·lb)

SHA906A

COMPRESSOR—Model MJS170

Leak Test

EVACUATE AND CONDUCT LEAK TEST

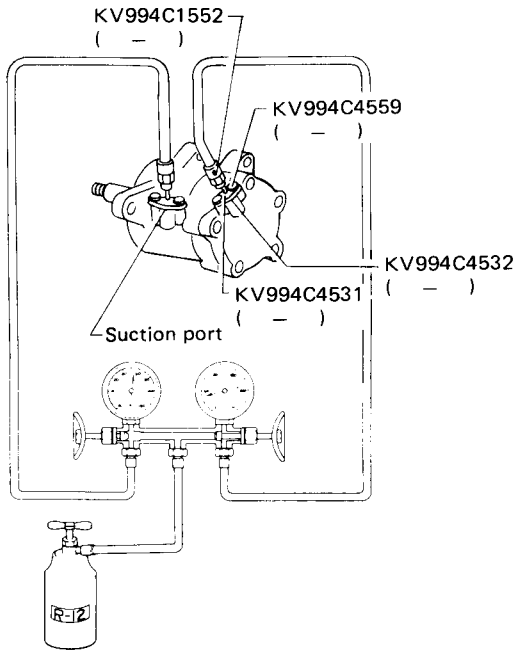

SHA907A

- When assembling clutch hub, adjust hub-to-pulley clearance with shims.

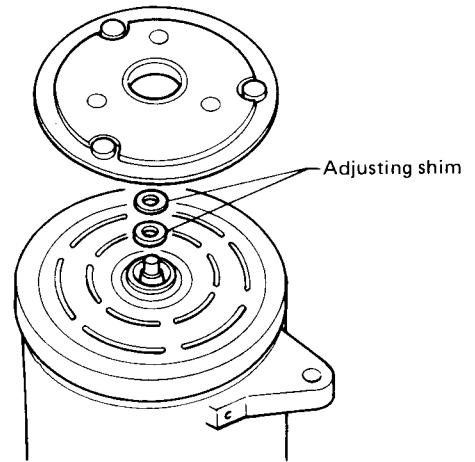

SHA272A

Clutch Replacement

- When removing shaft nut, hold clutch hub with Tool.
- Using Tool, clutch hub can be removed easily.

Tool No.: KV99412302 (J24878-1)

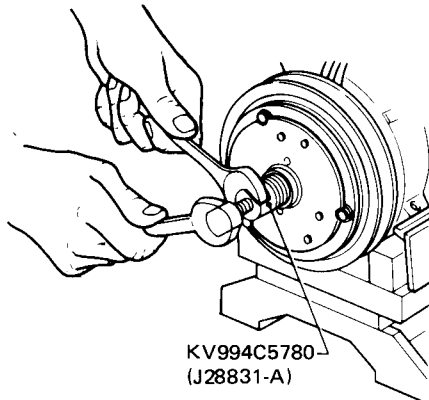

SHA268A

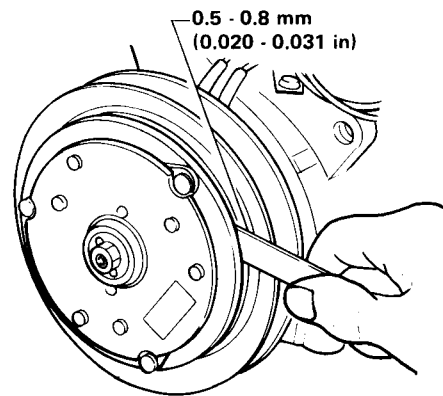

SHA908A

BREAK-IN OPERATION

When replacing compressor clutch assembly, do not forget break-in operation, accomplished by engaging and disengaging the clutch about thirty times. Break-in operation raises the level of transmitted torque.

COMPRESSOR—Model MJS170

Shaft Seal Replacement

- Before disassembling, be sure to measure the amount of oil.
After assembling, charge with the same amount of new oil.

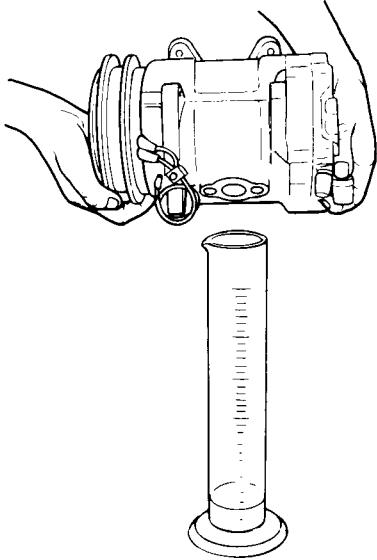

SHA033A

- When removing seal seat
Apply pressure with refrigerant.

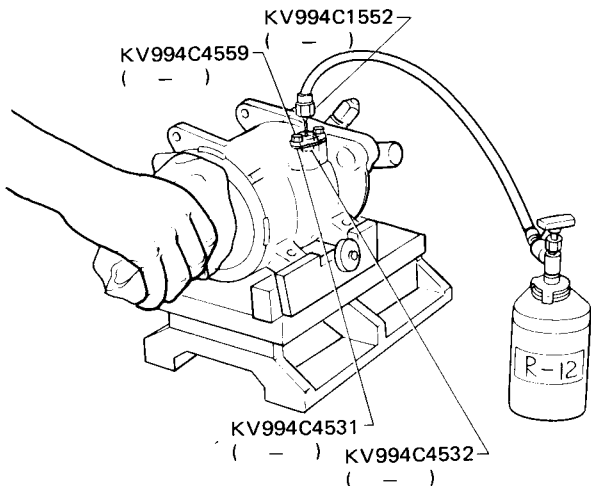

SHA274A

- With Tool, depress carbon seal and hook the case of shaft seal.

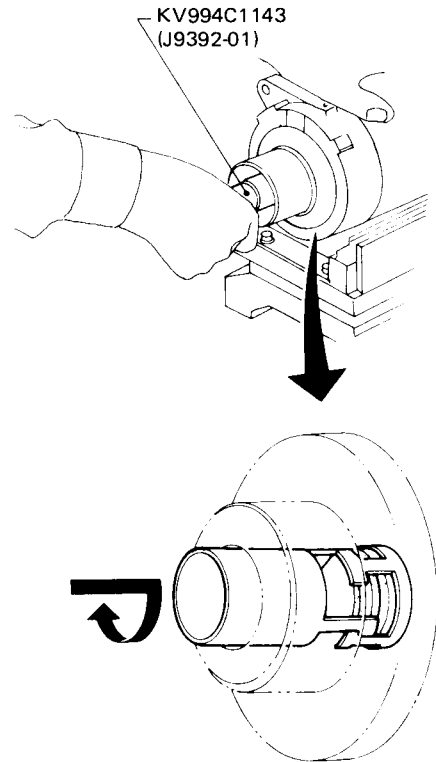

SHA275A

- When installing shaft seal
 - 1) Cap Tool to the top end of compressor shaft.
Tool number: KV994C5784 (J33212)
 - 2) Using Tool, insert shaft seal with shaft seal case and shaft cutout aligned.
Apply force to turn the seal somewhat to the left and right. Insure that shaft seal seats properly in the shaft cutout.

Tool number: KV994C1143 (J9392-01)

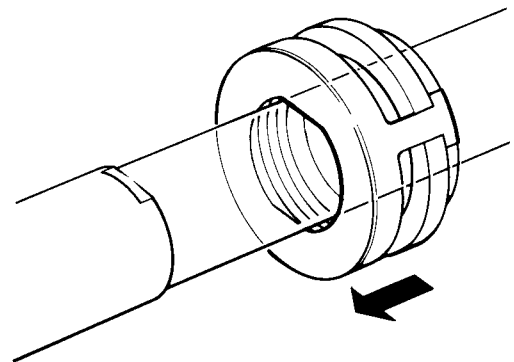

AC037

COMPRESSOR—Model MJS170

Valve Replacement

- Using Tool, remove rear cover.

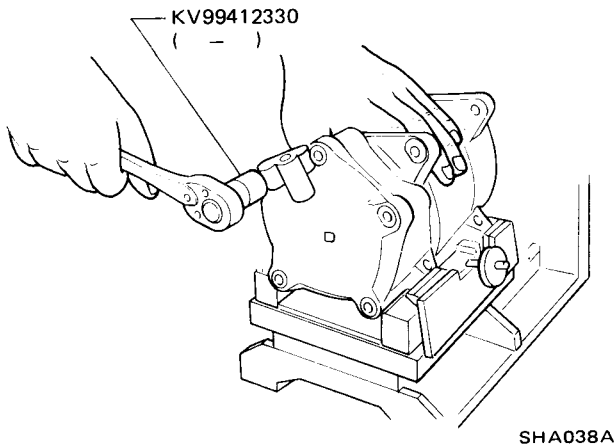

- Using Tool, remove rear cylinder head.

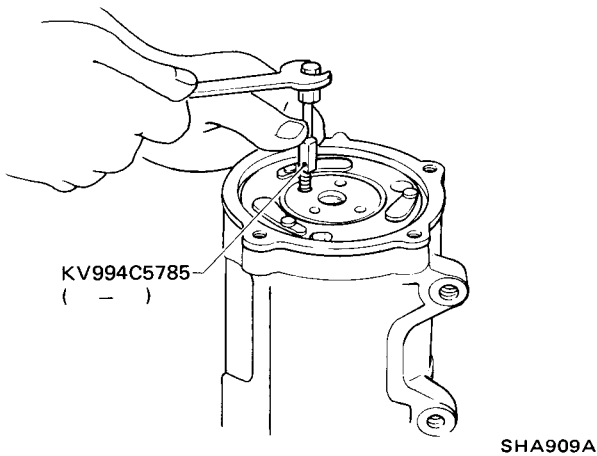

- When assembling

- 1) Front cover must be installed so that the cut-out portions of front cover and shell are aligned.

For this purpose, install front cover on cylinder head so that angle between threaded hole in front cover and low pressure side refrigerant passage in cylinder head is about 60° .

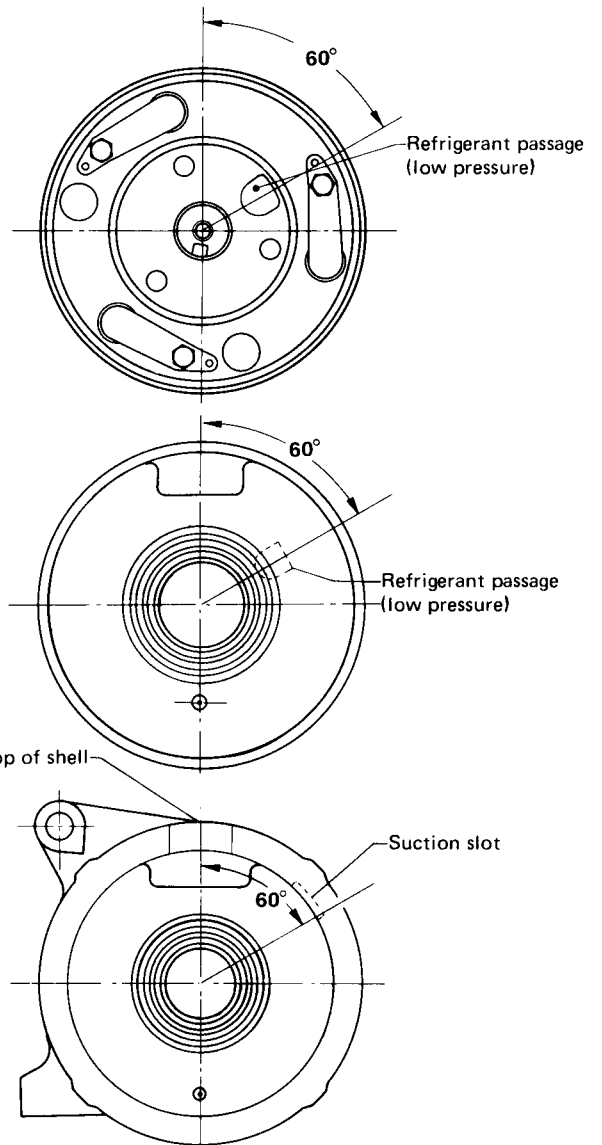

COMPRESSOR—Model MJS170

Valve Replacement (Cont'd)

- 2) When installing shell on cylinder, adjust position of shell so that suction inlet of shell opens in the same direction as suction slot of cylinder assembly. Then, make sure swash plate is visible in suction inlet by removing suction valve.

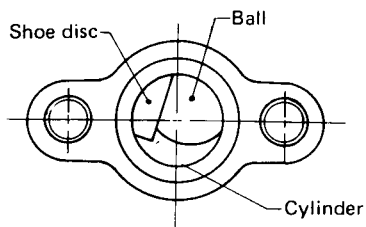
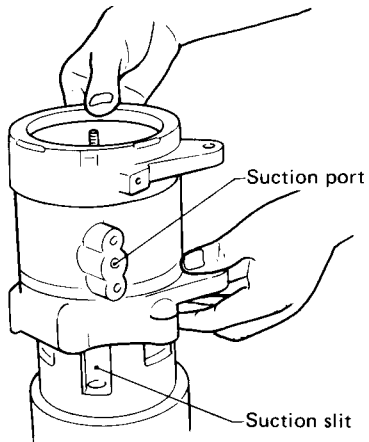
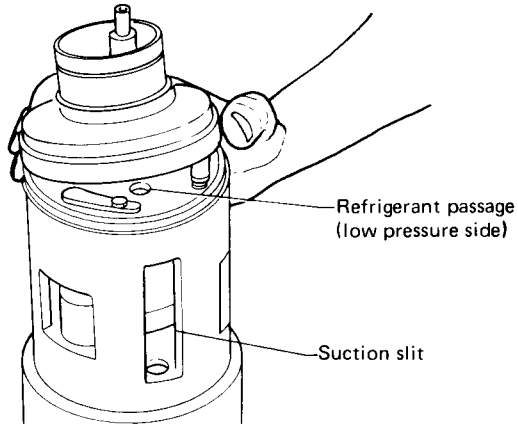

SHA277A

A/C ELECTRICAL CIRCUIT (Manual)

Schematic

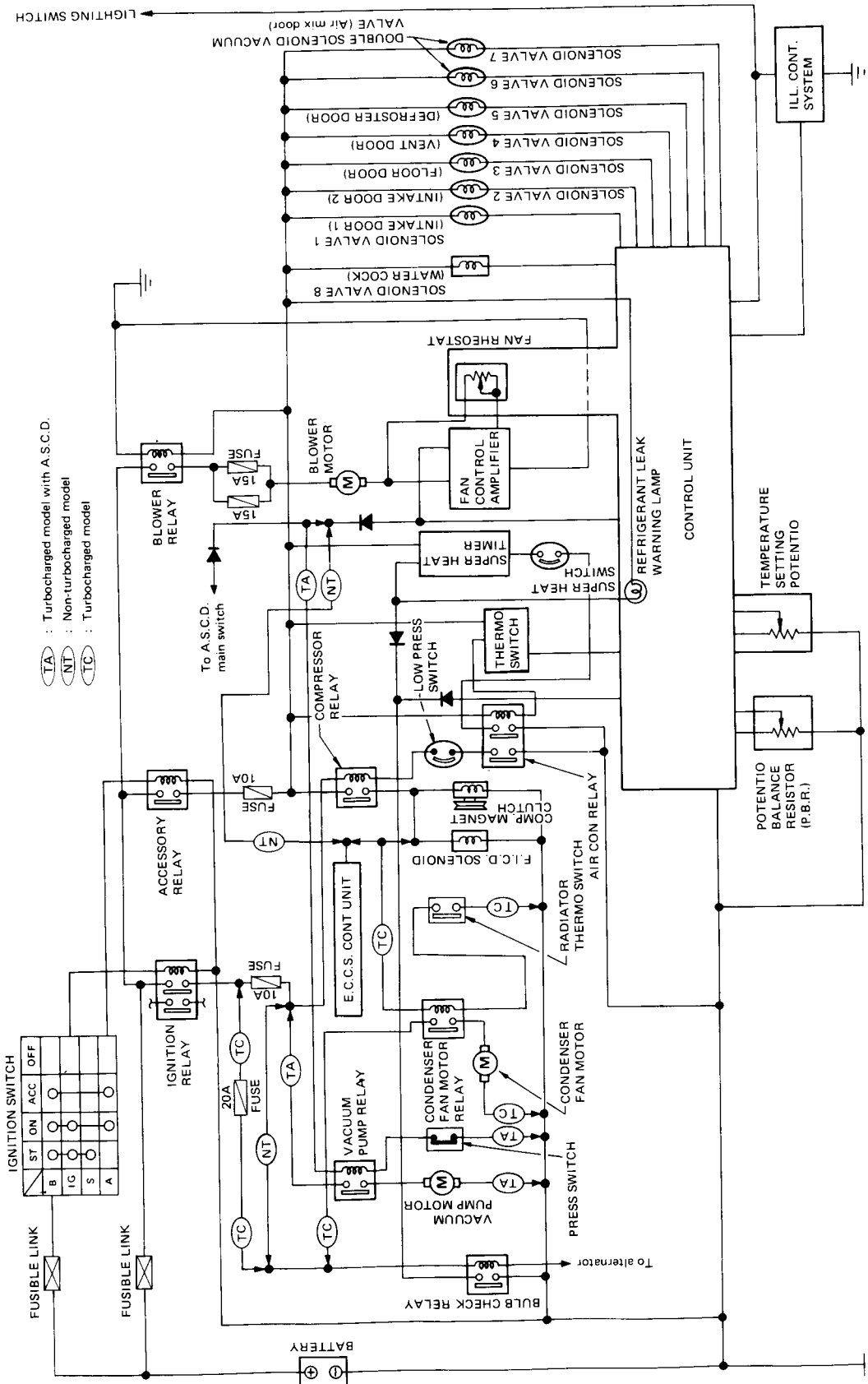

SHA522B

A/C ELECTRICAL CIRCUIT (Manual)

Wiring Diagram

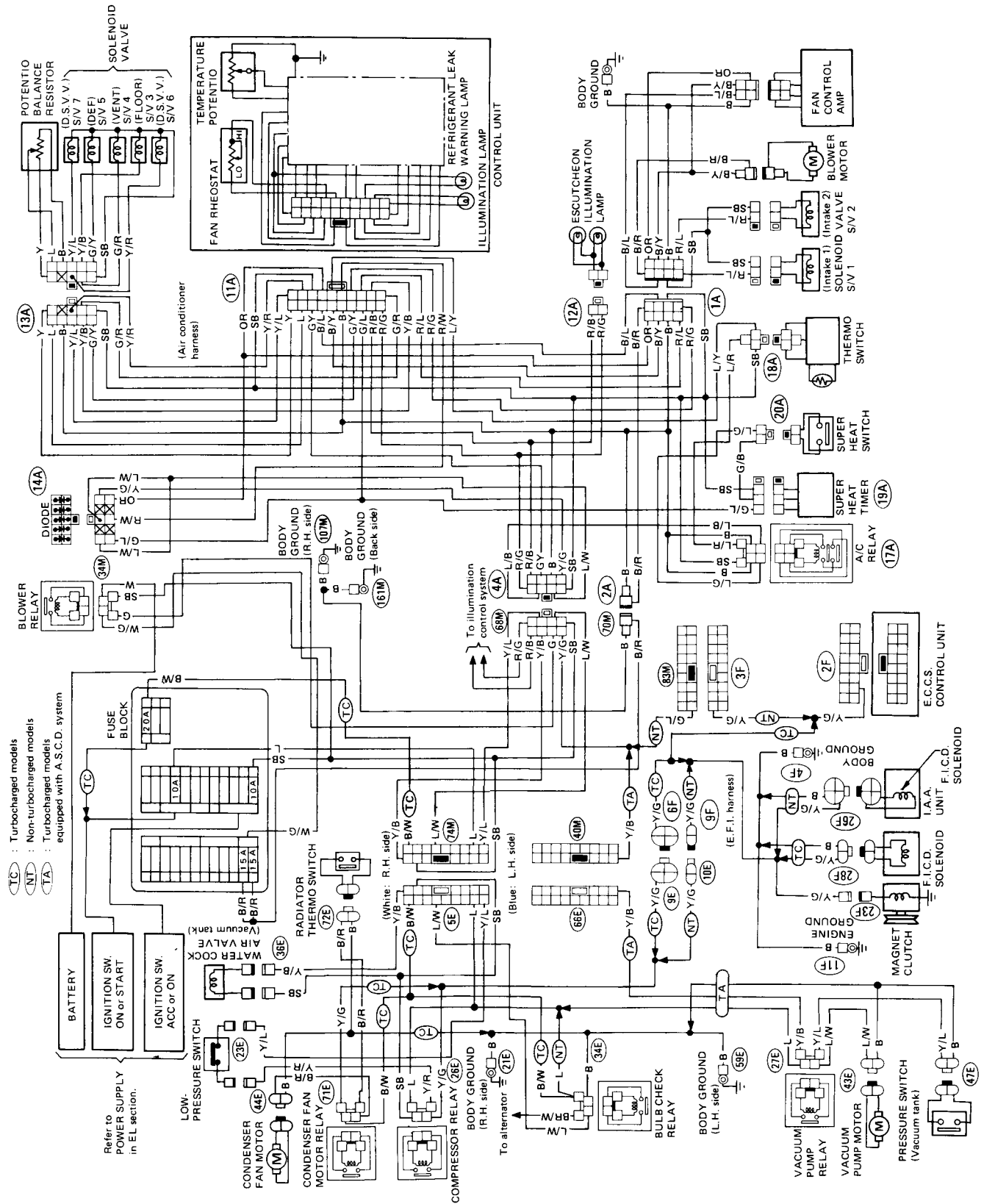

A/C ELECTRICAL COMPONENTS (Manual)

Inspection

SUPER HEAT SWITCH

- Dip the temperature sensor of the super heat switch in a container filled with cold water and increase the temperature of the water. The switch should turn "ON".

NOTICE

- Do not allow the switch to get into water.
- Wipe water from temperature sensor section after checking it.

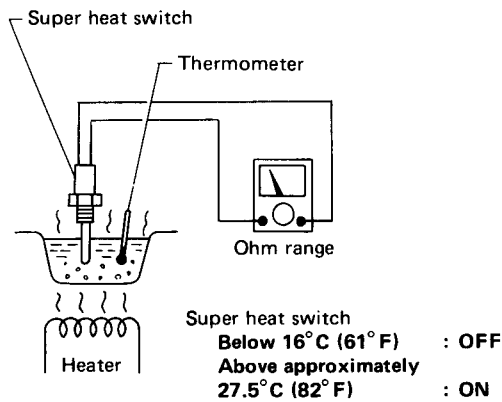

SHA251B

SUPER HEAT TIMER

- Make sure contacts of super heat timer close (continuity exists) after a constant current has passed through the timer for a certain period of time.

Time while applying voltage (12V) to the terminals between ① and ② (Sec)	Resistance between ② and ③ (Ω)
Less than 105	∞
More than 175	Less than 400

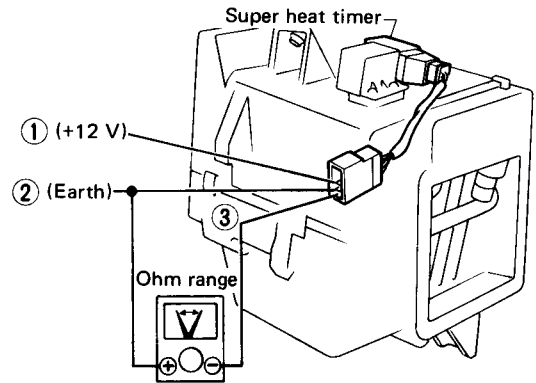

SHA252B

VACUUM TANK

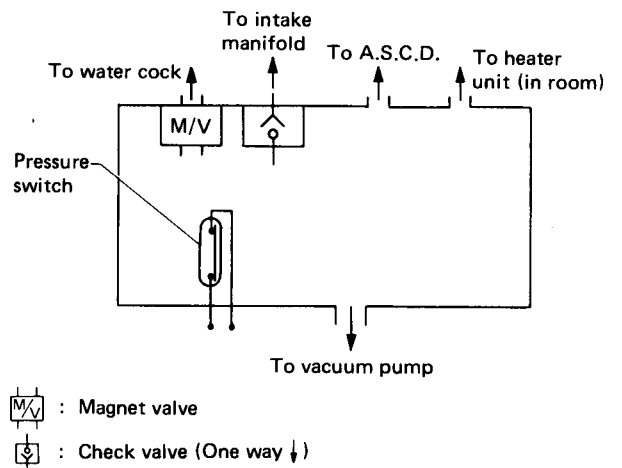

SHA253B

Solenoid valve check for water cock

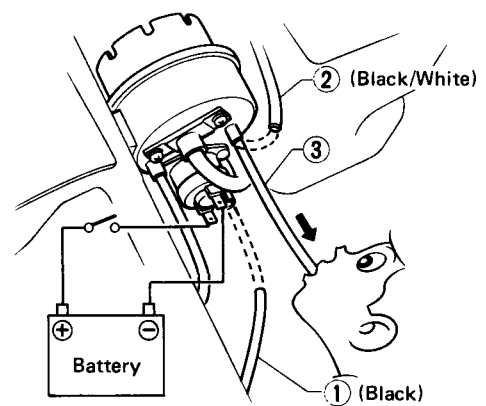

SHA254B

A/C ELECTRICAL COMPONENTS (Manual)

Inspection (Cont'd)

1. Disconnect vacuum hose ①.
2. Disconnect vacuum hose ② and connect hose ③ instead. Suck in through hose ③ to confirm that air does not flow through the hose and that check valve is closed.
3. While sucking vacuum hose ③, change voltage to solenoid to check for open-close operation of solenoid valve.

Applied voltage to solenoid (V)	Operation of solenoid valve
0	Close
12	Open

Pressure switch check for turbocharged model

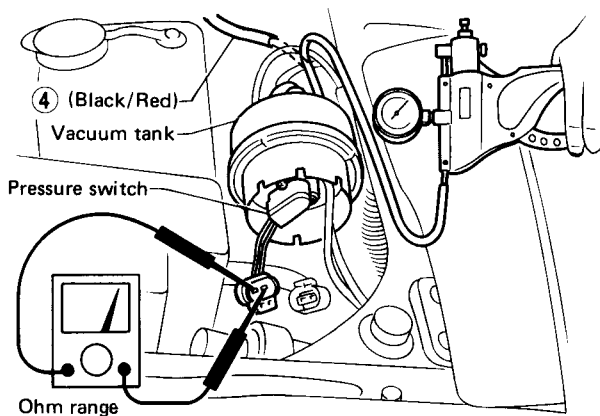

Pressure	Resistance (Ω)
Atmospheric pressure	0
Vacuum pressure more than 46.7 kPa (350 mmHg, 13.78 inHg)	∞

SHA255B

1. Disconnect vacuum hose ④ from the terminal and connect a vacuum handy pump with the same terminal.
2. Check pressure switch using a vacuum handy pump.

VACUUM PUMP MOTOR

1. Turn ignition switch "OFF". Disconnect vacuum hose ④ (Refer to "Pressure Switch Check") from vacuum tank and connect it again.
2. Make sure air conditioner switch is "OFF".
3. Turn ignition switch "ON" (Do not start the engine).
4. Push cruise control main switch to make sure vacuum pump starts. (A sound should be heard from the pump.)
5. The vacuum pump is operating properly if it stops within 20 seconds after it has started.
6. If it fails to stop within 20 seconds, and vacuum hoses are in good order, it is malfunctioning.

SOLENOID VALVE

Perform operational check, referring to the "Table of operation of solenoid valve in Air Flow (page HA-3) and Wiring Diagram (page HA-8 or HA-31).

LOCATION OF A/C ELECTRICAL COMPONENTS (Manual)

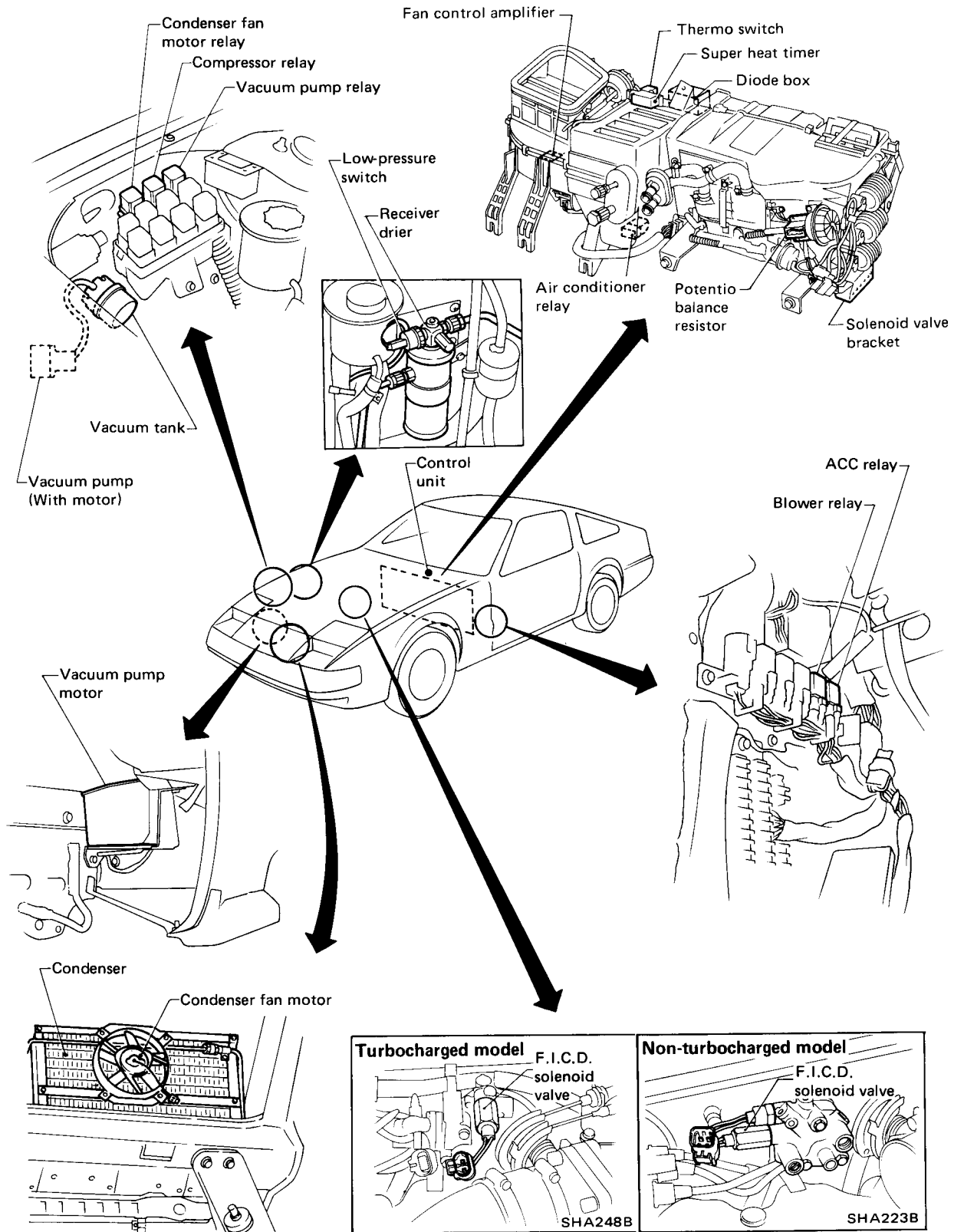

SHA256B

TROUBLE DIAGNOSES (Manual)

CONTENTS

Circuit for Trouble Diagnoses	HA-36
Preliminary Check	HA-37
1) Insufficient cooling (Mode switch position: "FACE")	HA-37
2) Insufficient heating	HA-38
3) Insufficient air flow (Blower motor does not rotate.)	HA-39
4) Abnormal sound	HA-40
Trouble Diagnoses from Abnormal Conditions	HA-41
(A) Blower motor does not rotate.	HA-41
(B) Air flow cannot be changed between HI and LO.	HA-42
(C) Blower motor continues to rotate when fan switch is turned off.	HA-43
(D) "FACE" mode cannot be set.	HA-44
(E) "B/L" mode cannot be set.	HA-46
(F) "FOOT" mode cannot be set.	HA-48
(G) "DEMIST" mode cannot be set.	HA-50
(H) "DEF" mode cannot be set.	HA-52
(I) Outlet air will not become warm.	HA-53
(J) Outlet air will not become cool.	HA-55
(K) Outlet air temperature cannot be changed with temp. control lever.	HA-58
(L) Malfunction of water cock operation	HA-58
(M) Outlet air temperature fluctuates.	HA-59
(N) Recirculation mode cannot be set when "REC" switch is pressed.	HA-61
(P) Outside air is not drawn into compartment when "REC" switch is turned off.	HA-61
(Q) Compressor clutch is not engaged.	HA-62
(R) Malfunction of F.I.C.D.	HA-65
(S) Blower motor rotates intermittently.	HA-66

TROUBLE DIAGNOSES (Manual)

Circuit for Trouble Diagnoses

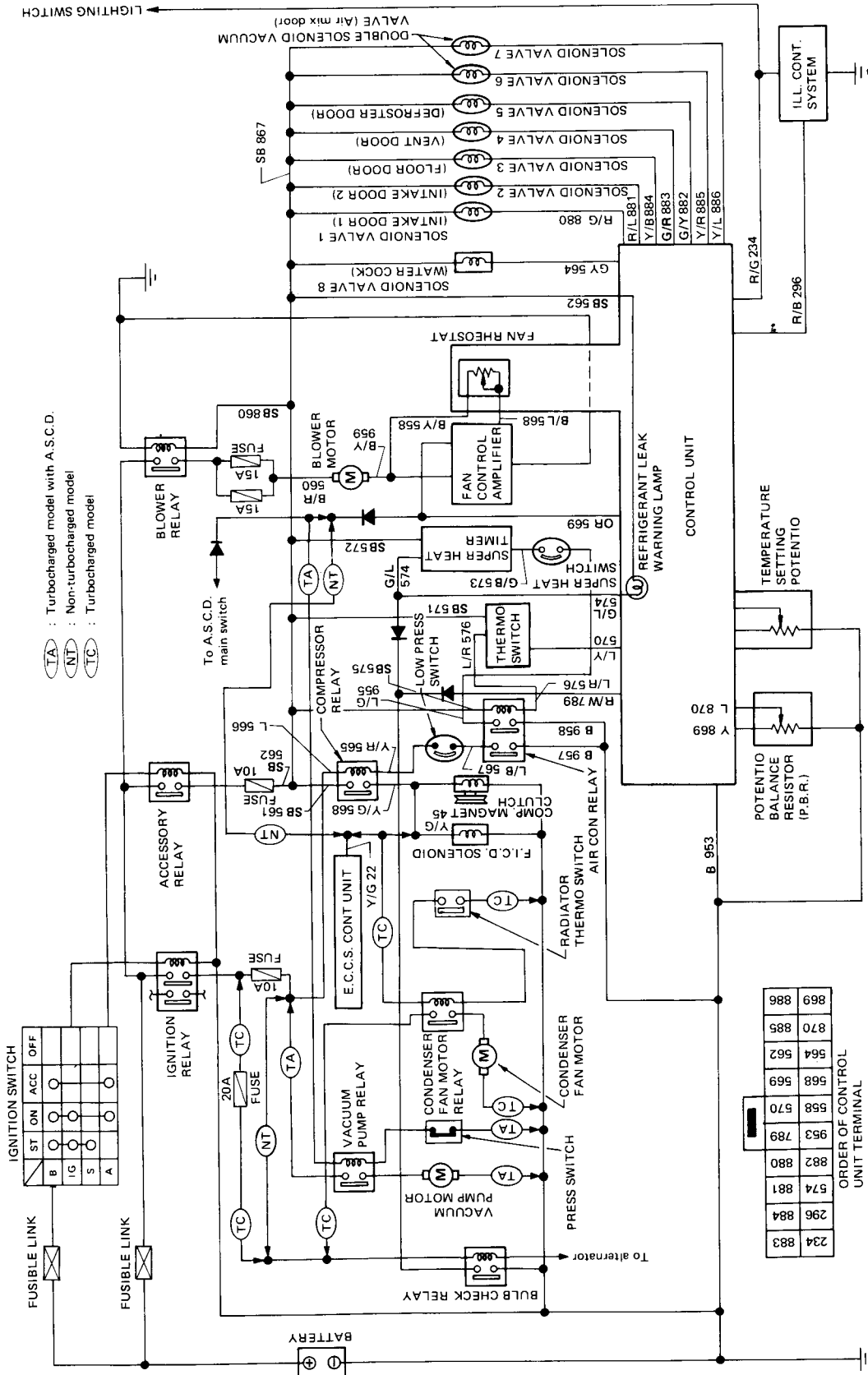

TROUBLE DIAGNOSES (Manual)

Preliminary Check

Before starting to diagnose the trouble, check the items below in order to completely understand the trouble symptom.

1) INSUFFICIENT COOLING (Mode switch position: "FACE")

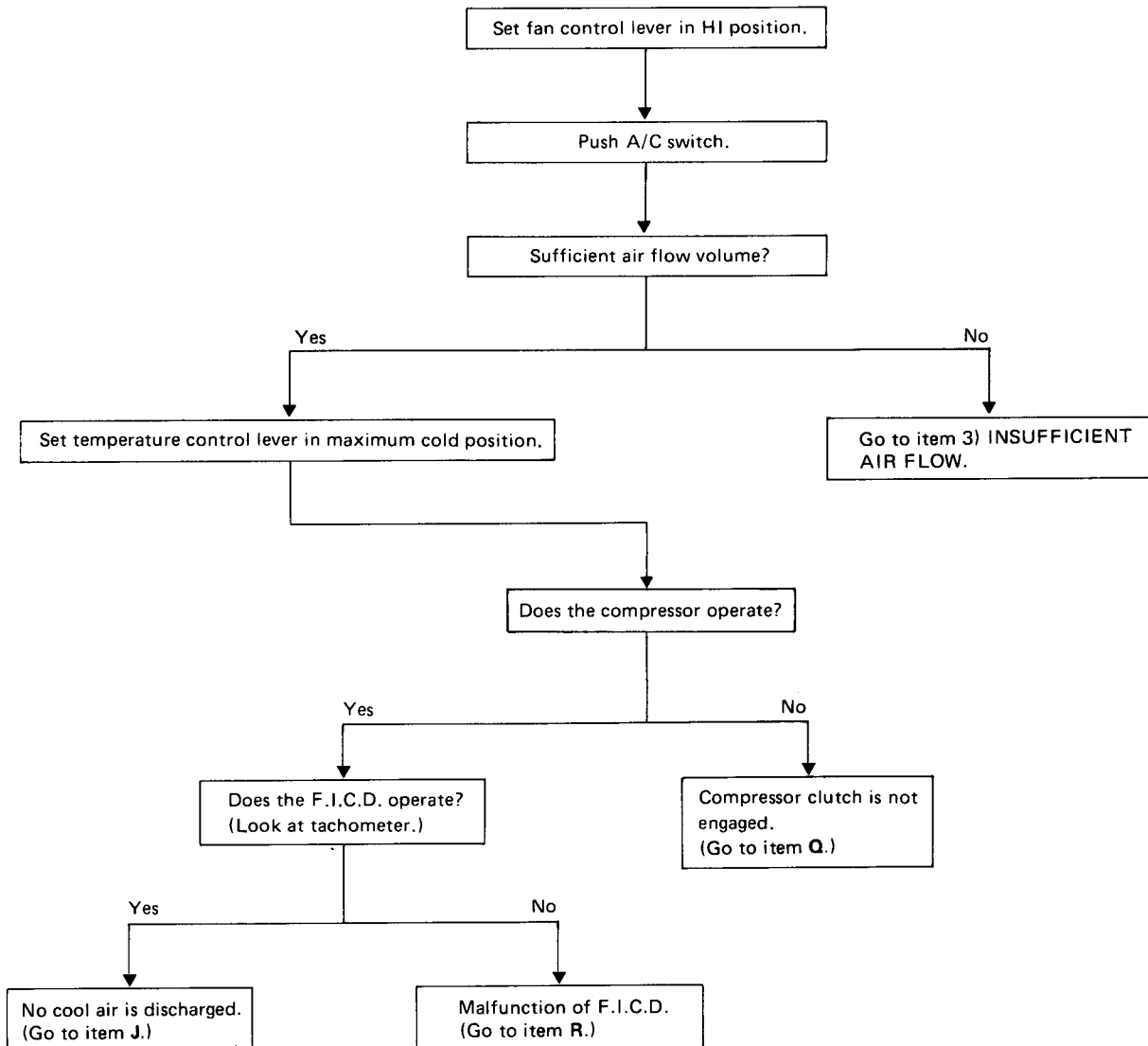

TROUBLE DIAGNOSES (Manual)

Preliminary Check (Cont'd)

2) INSUFFICIENT HEATING

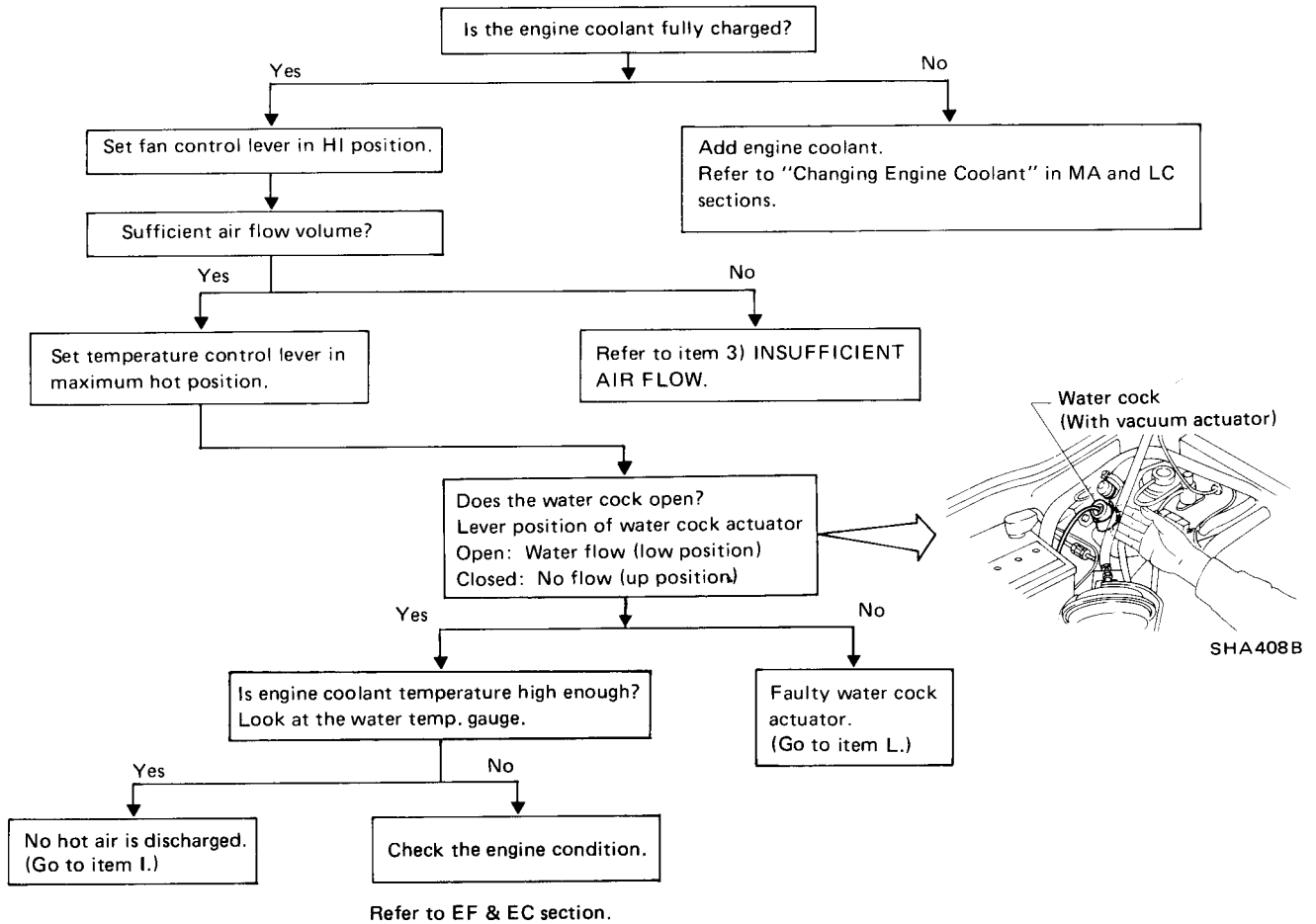

TROUBLE DIAGNOSES (Manual)

Preliminary Check (Cont'd)

3) INSUFFICIENT AIR FLOW (Blower motor does not rotate.)

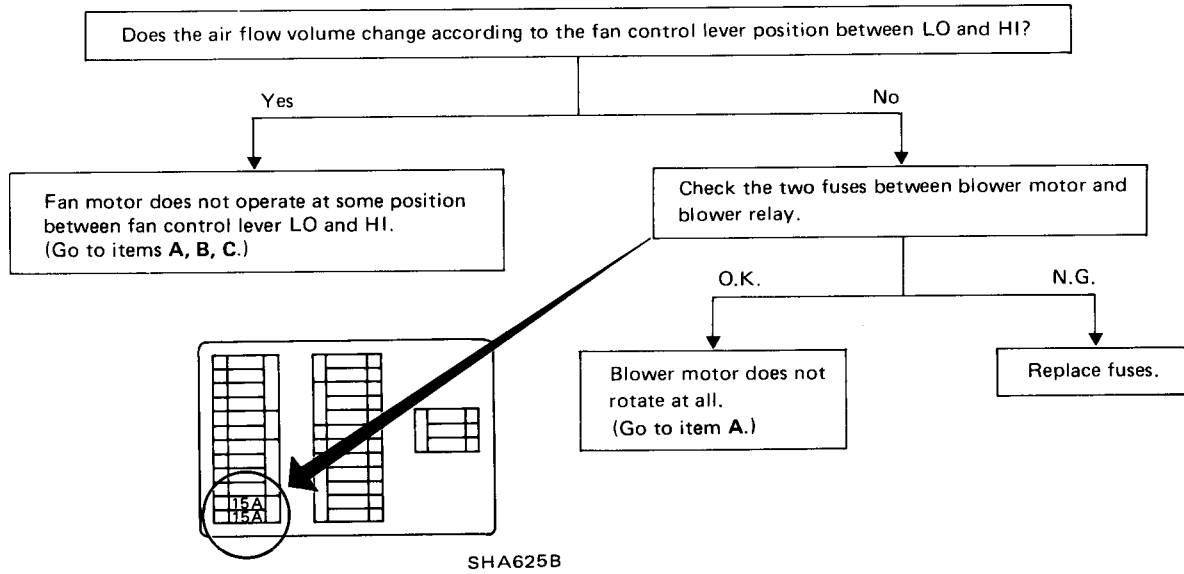

TROUBLE DIAGNOSES (Manual)

Preliminary Check (Cont'd)

4) ABNORMAL SOUND

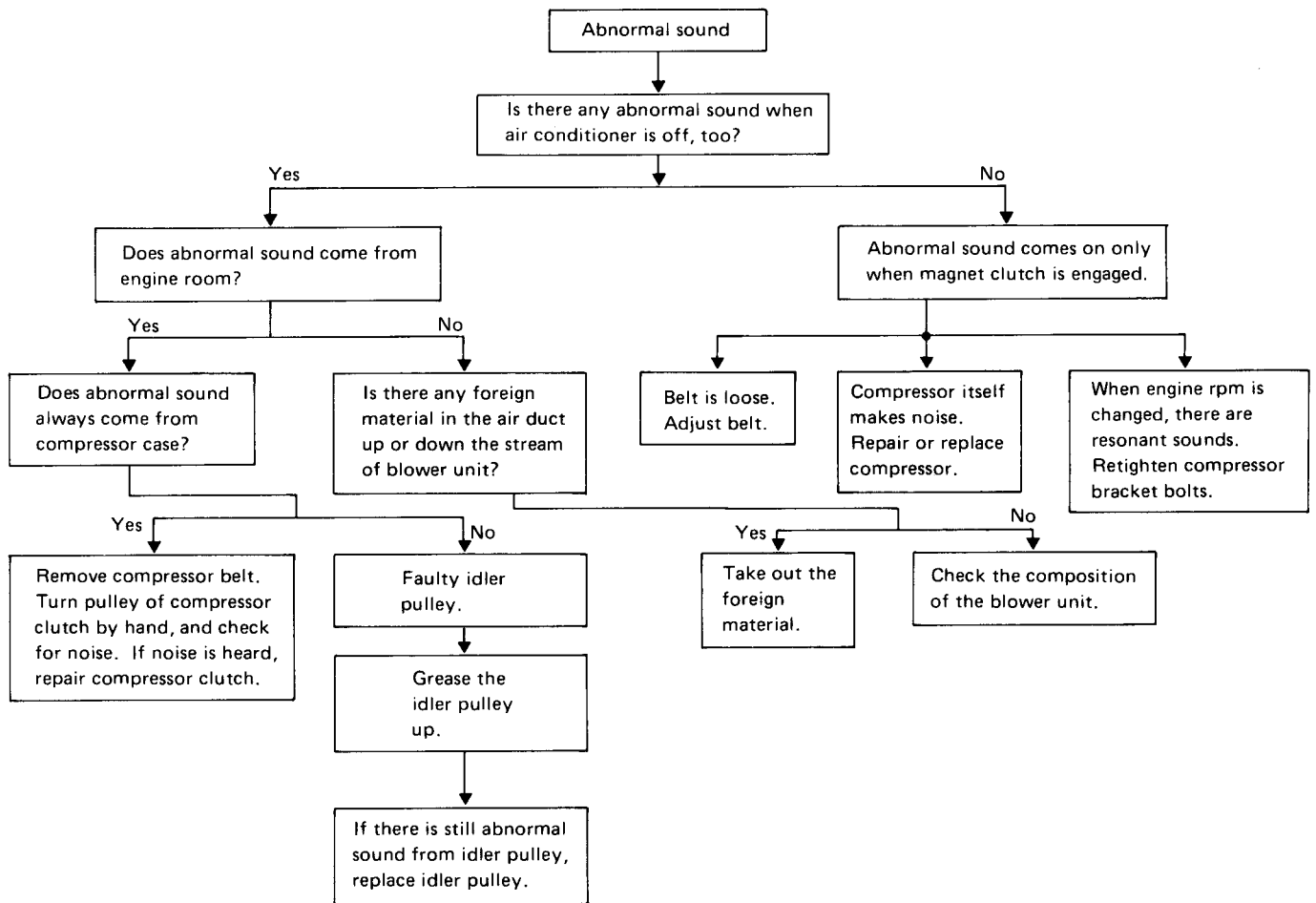

TROUBLE DIAGNOSES (Manual)

Trouble Diagnoses from Abnormal Conditions

(A) BLOWER MOTOR DOES NOT ROTATE. (Ignition switch on position)

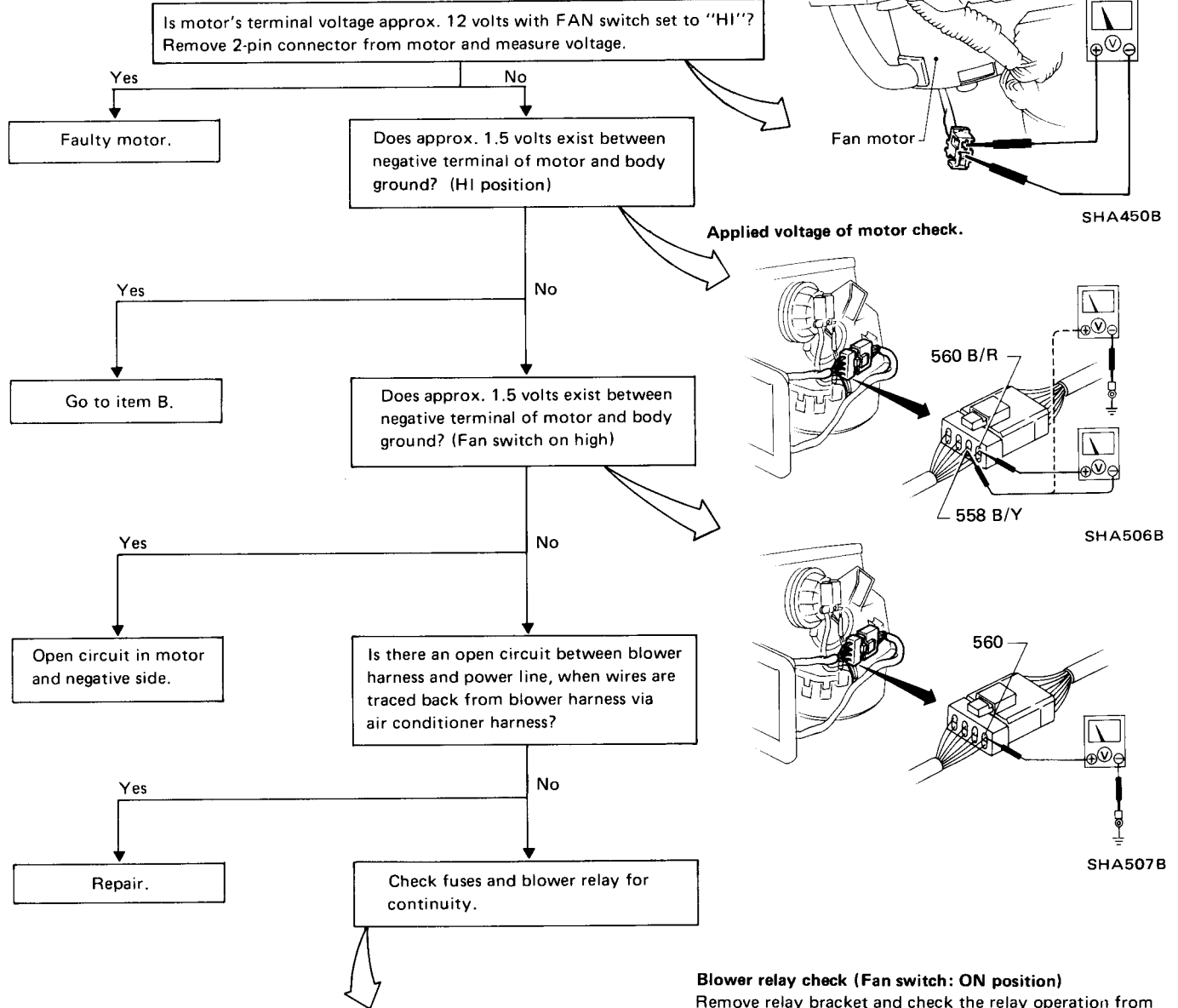

Fuse check (Ignition switch: OFF position)

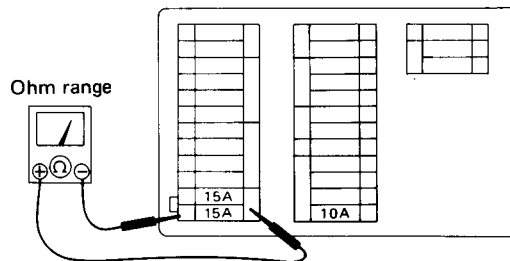

Blower relay check (Fan switch: ON position)

Remove relay bracket and check the relay operation from the back side of the electrical connector.

- ① Terminal voltage check (Correct voltage: Approx. 12V)
- ② If item ① is N.G., check applied voltage of relay coil. (Correct voltage: Approx. 12V)

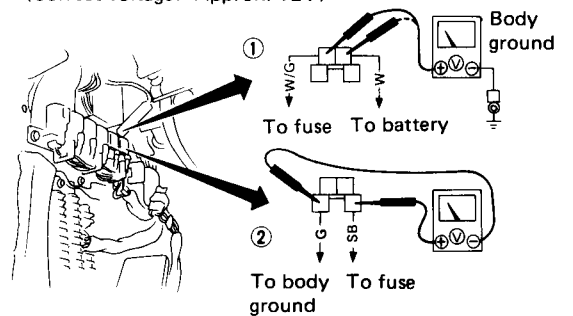

SHA396B

TROUBLE DIAGNOSES (Manual)

Trouble Diagnoses from Abnormal Conditions (Cont'd)

(B) AIR FLOW CANNOT BE CHANGED BETWEEN HI AND LO.

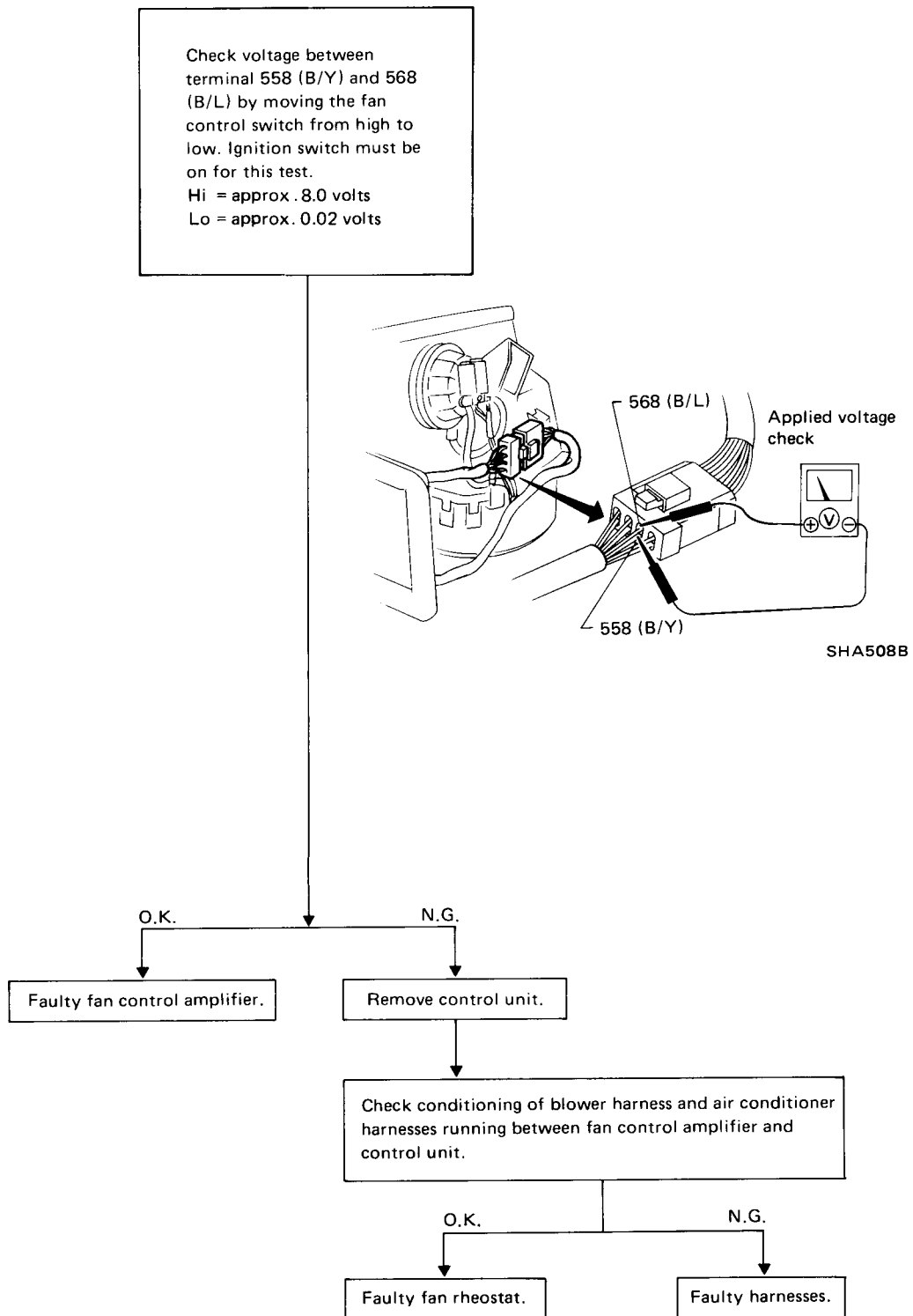

TROUBLE DIAGNOSES (Manual)

Trouble Diagnoses from Abnormal Conditions (Cont'd)

(C) BLOWER MOTOR CONTINUES TO ROTATE WHEN FAN SWITCH IS TURNED OFF.

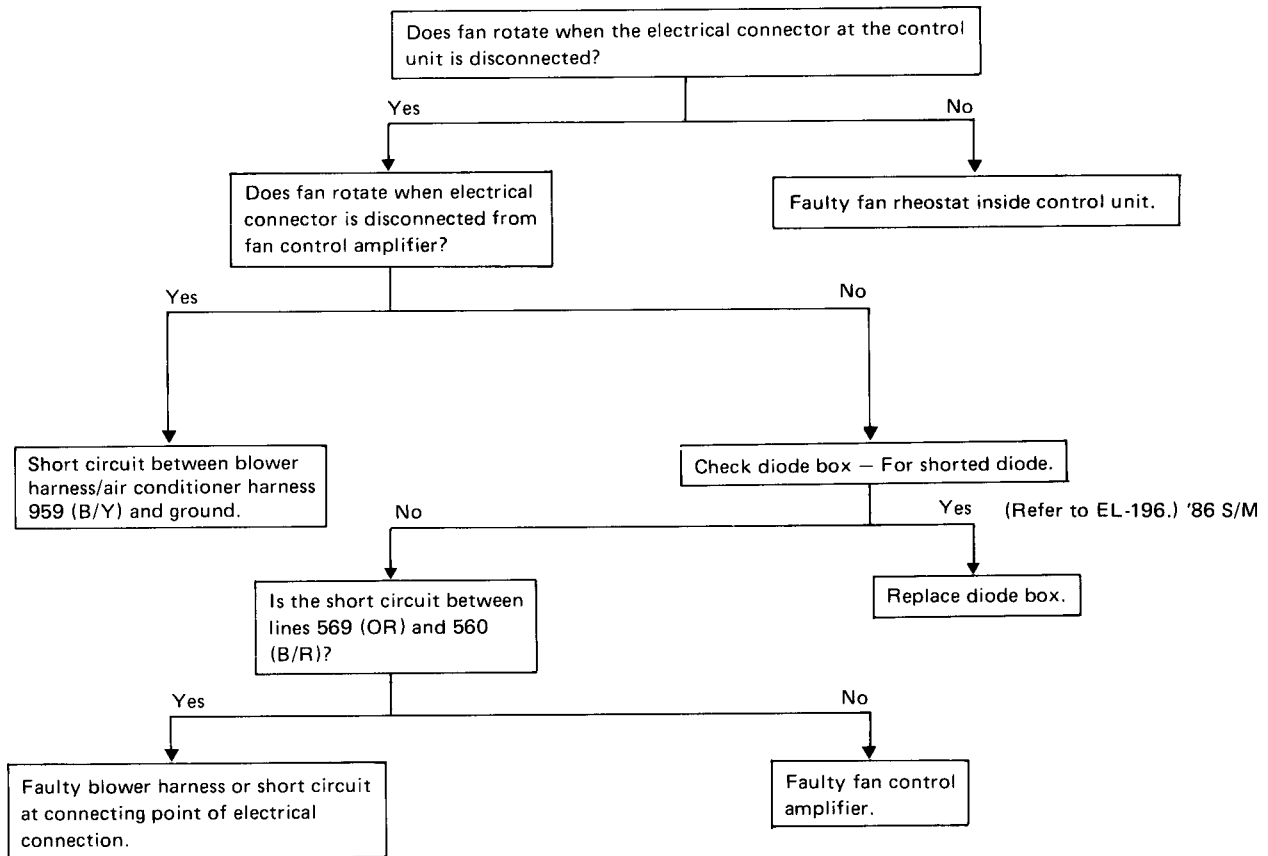

TROUBLE DIAGNOSES (Manual)

Trouble Diagnoses from Abnormal Conditions (Cont'd)

(D) "FACE" MODE CANNOT BE SET.

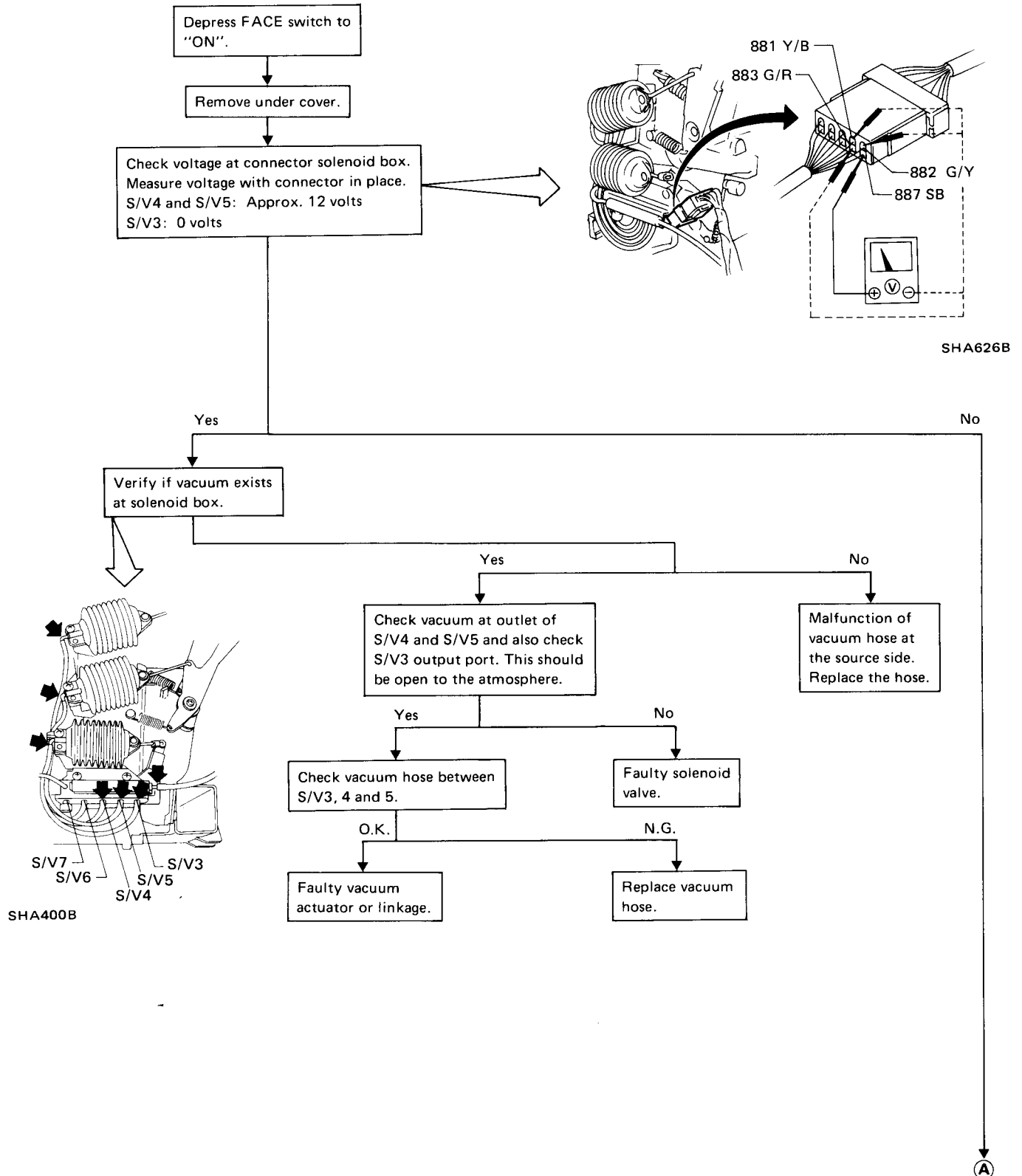

TROUBLE DIAGNOSES (Manual)

Trouble Diagnoses from Abnormal Conditions (Cont'd)

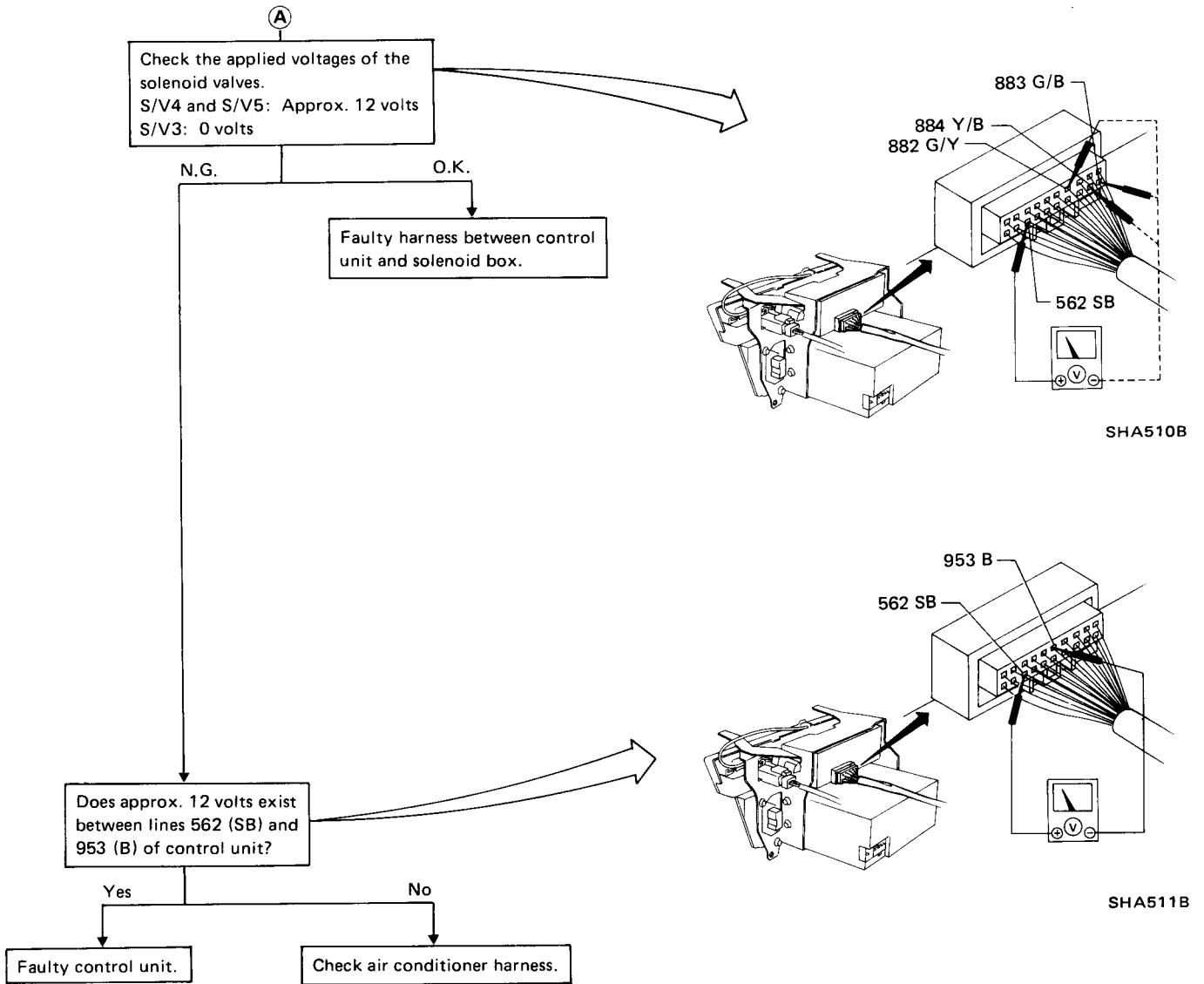

TROUBLE DIAGNOSES (Manual)

Trouble Diagnoses from Abnormal Conditions (Cont'd)

(E) "B/L" MODE CANNOT BE SET.

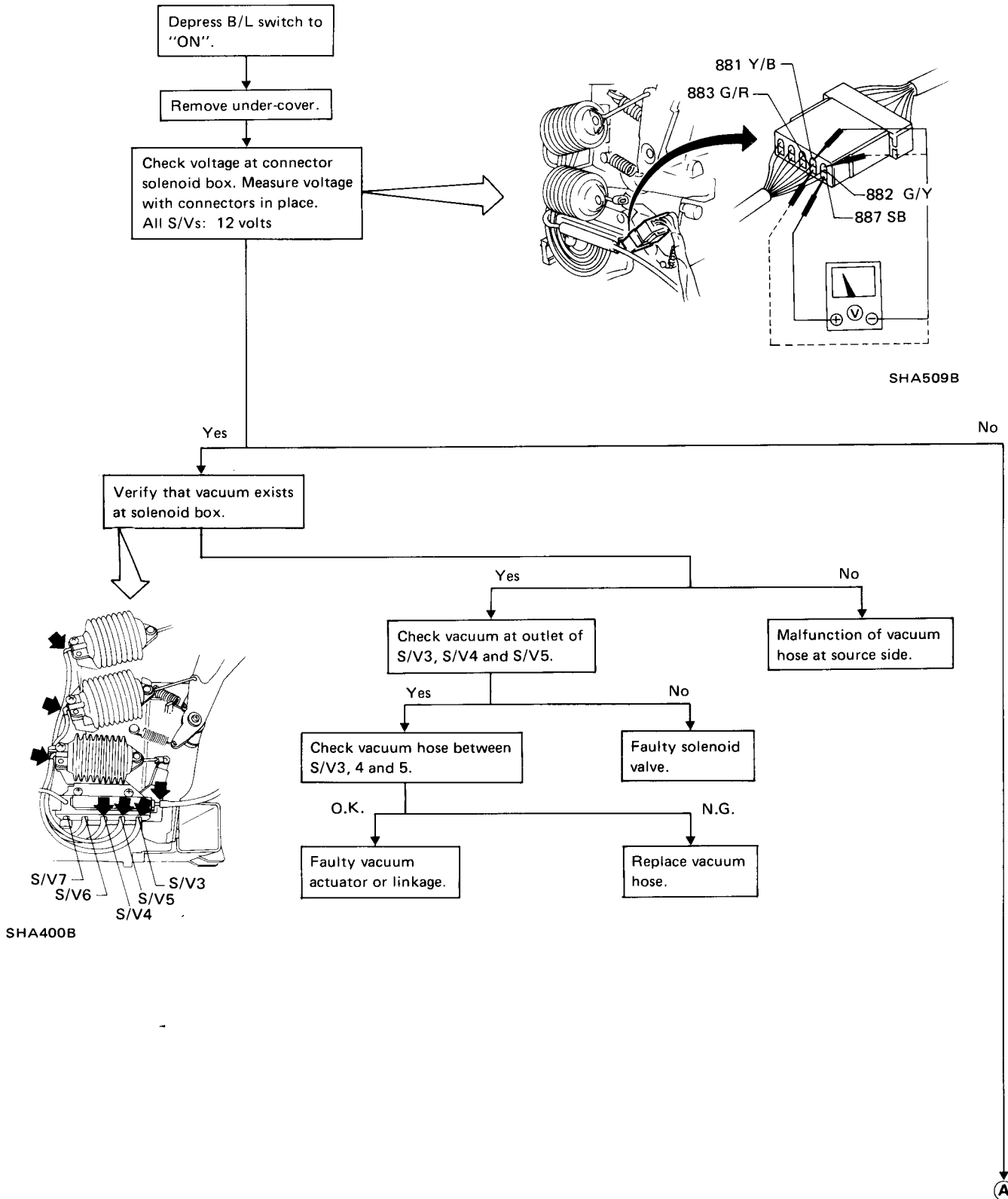

TROUBLE DIAGNOSES (Manual)

Trouble Diagnoses from Abnormal Conditions (Cont'd)

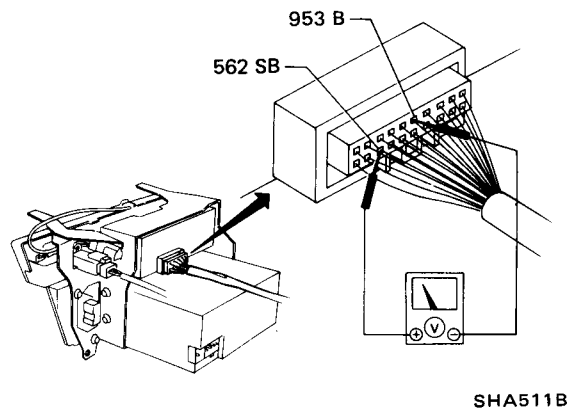
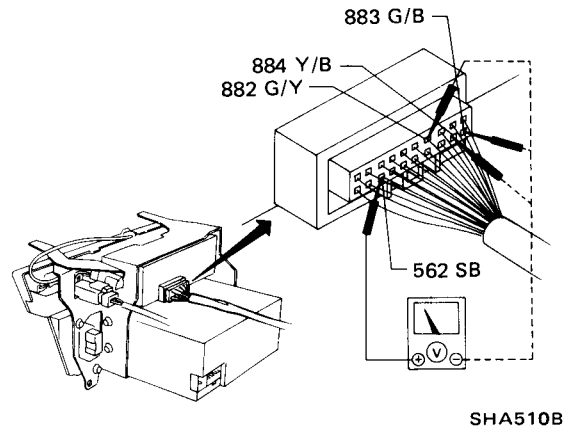
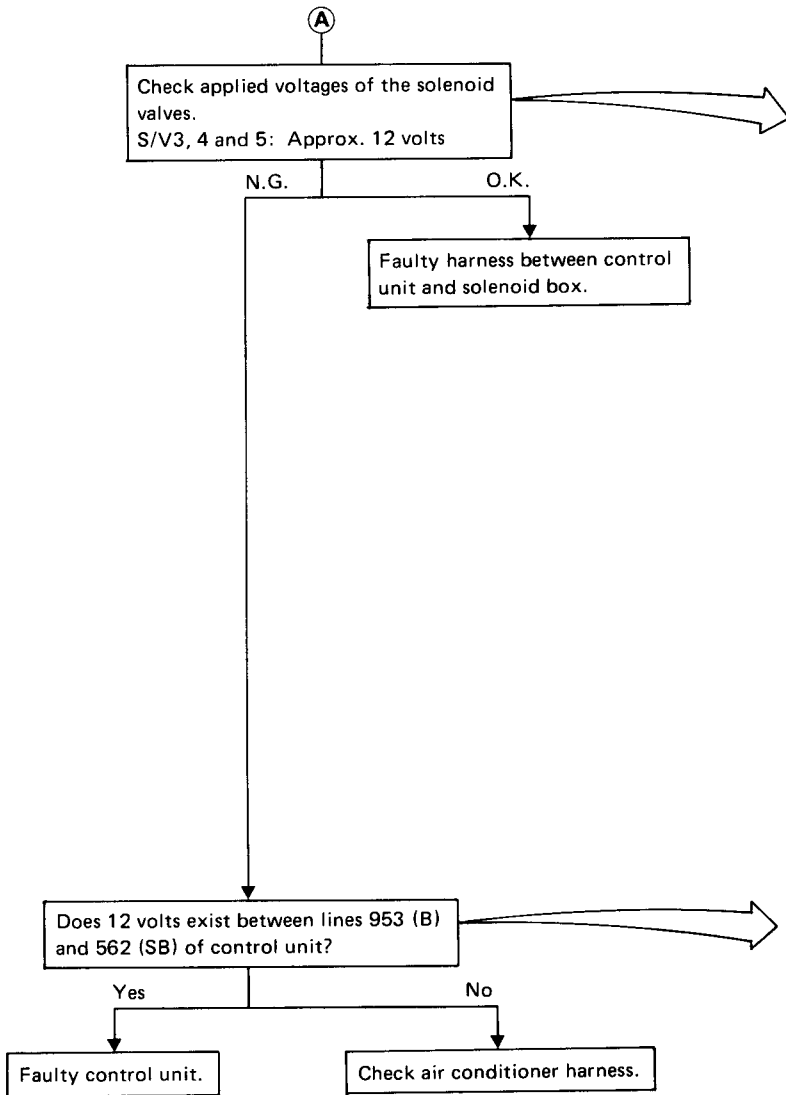

TROUBLE DIAGNOSES (Manual)

Trouble Diagnoses from Abnormal Conditions (Cont'd)

(F) "FOOT" MODE CANNOT BE SET.

Depress FOOT switch to "ON".

Remove under-cover.

Check voltage at connector solenoid box. Measure voltage with connector in place.

- S/V3 and S/V5: Approx. 12 volts
- S/V4: Approx. 0 volts

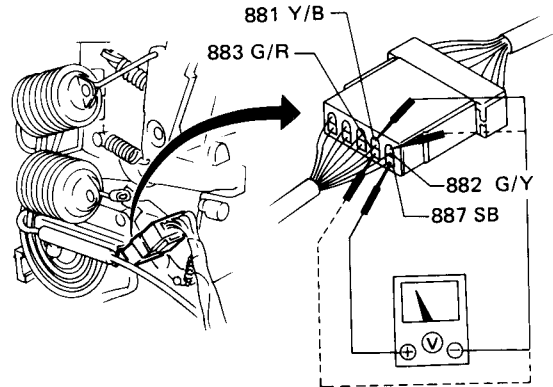

SHA509B

Yes

No

Check vacuum at the inlet of the solenoid box.

Yes

No

Check vacuum at the outlets of S/V3 and 5. Check S/V4—this should be opened to atmosphere.

Faulty vacuum hose at source side.

Yes

No

Check vacuum hose between solenoid valves and vacuum actuator.

Faulty solenoid valve.

O.K.

N.G.

Faulty vacuum actuator or linkage.

Replace vacuum hose.

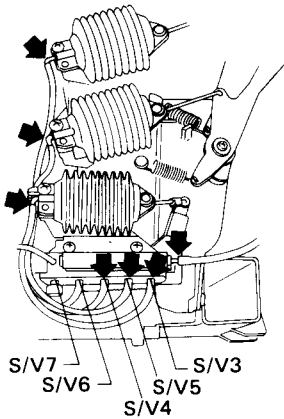

SHA400B

A

TROUBLE DIAGNOSES (Manual)

Trouble Diagnoses from Abnormal Conditions (Cont'd)

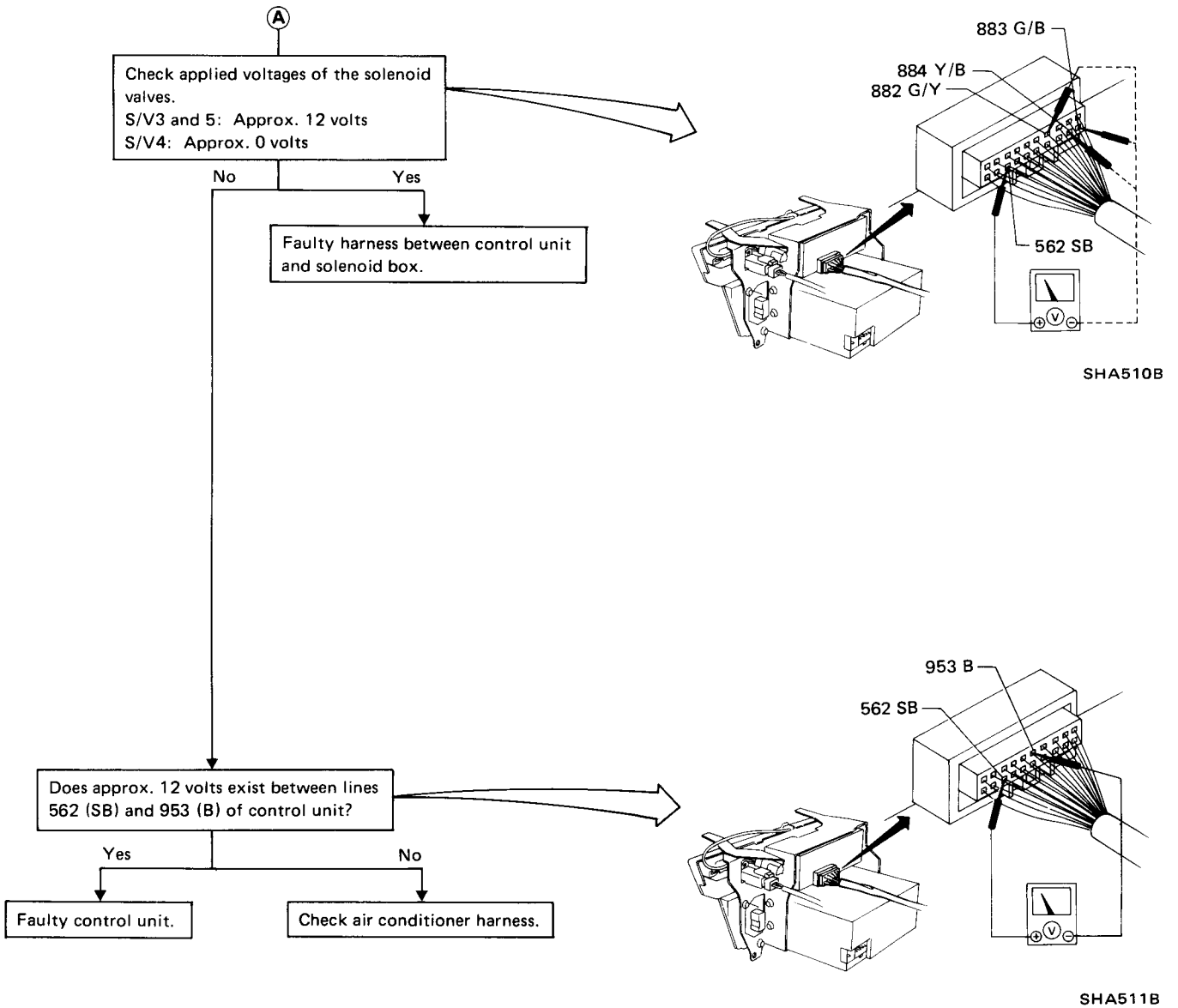

TROUBLE DIAGNOSES (Manual)

Trouble Diagnoses from Abnormal Conditions (Cont'd)

(G) "DEMIST" MODE CANNOT BE SET.

Depress DEMIST switch to "ON".

Remove under-cover from driver's side.

Check voltage at connector solenoid box.
Measure voltage with connector in place.
S/V4 and 5: Approx. 0 volts
S/V3: Approx. 12 volts

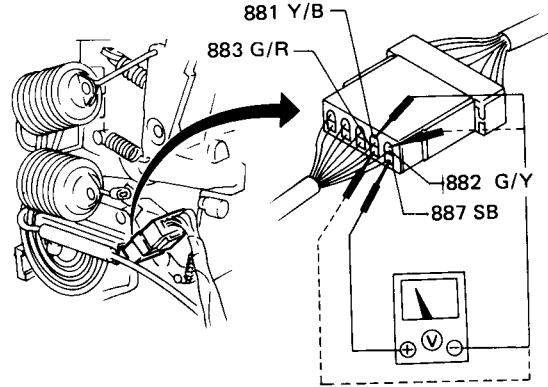

SHA509B

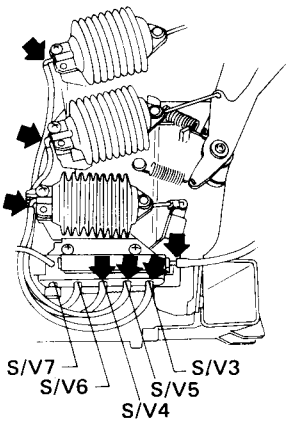
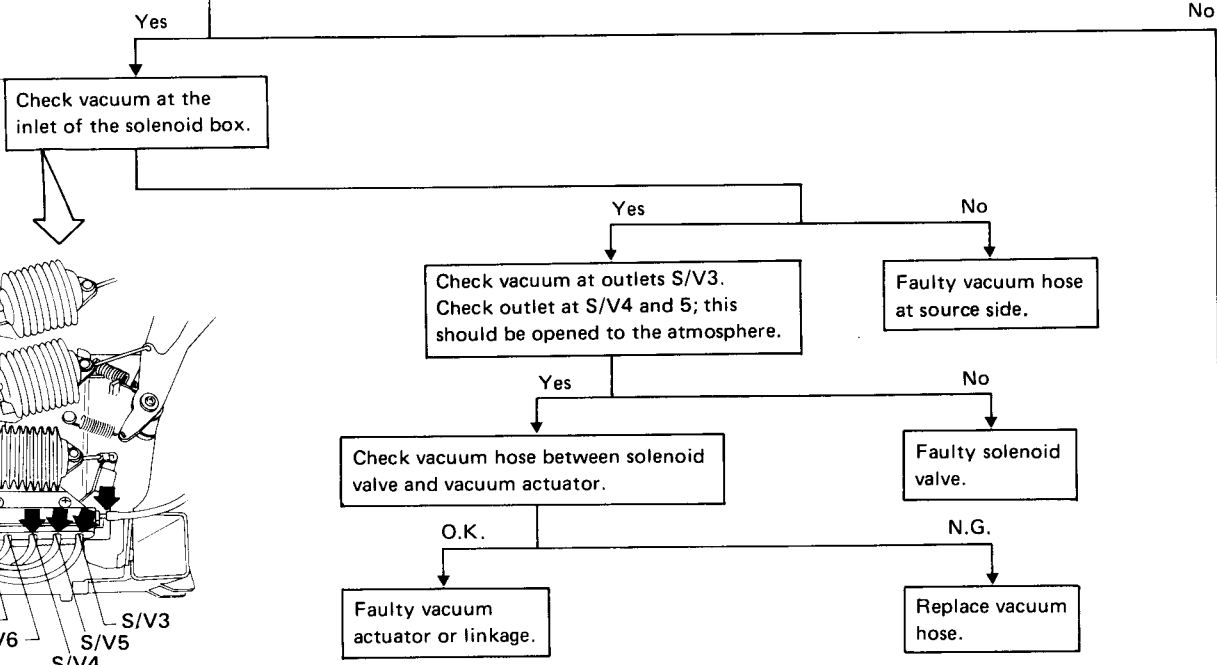

SHA400B

(A)

TROUBLE DIAGNOSES (Manual)

Trouble Diagnoses from Abnormal Conditions (Cont'd)

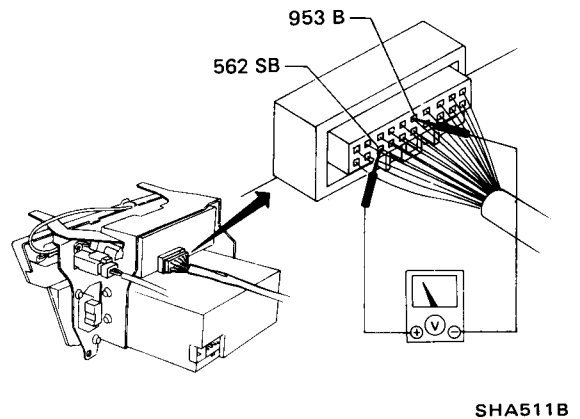
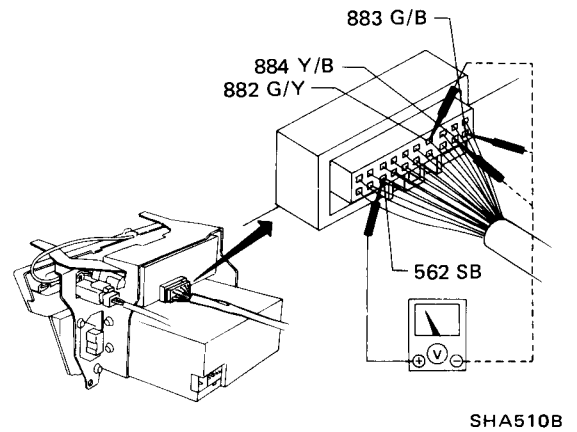
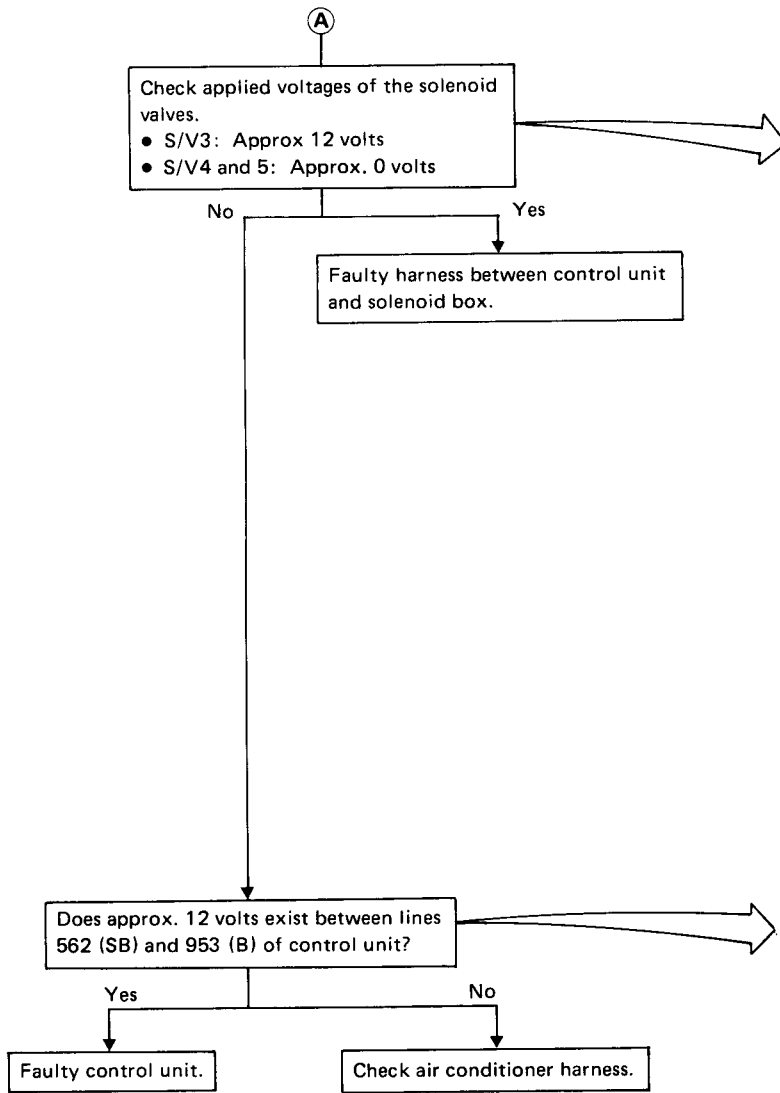

TROUBLE DIAGNOSES (Manual)

Trouble Diagnoses from Abnormal Conditions (Cont'd)

(H) "DEF" MODE CANNOT BE SET.

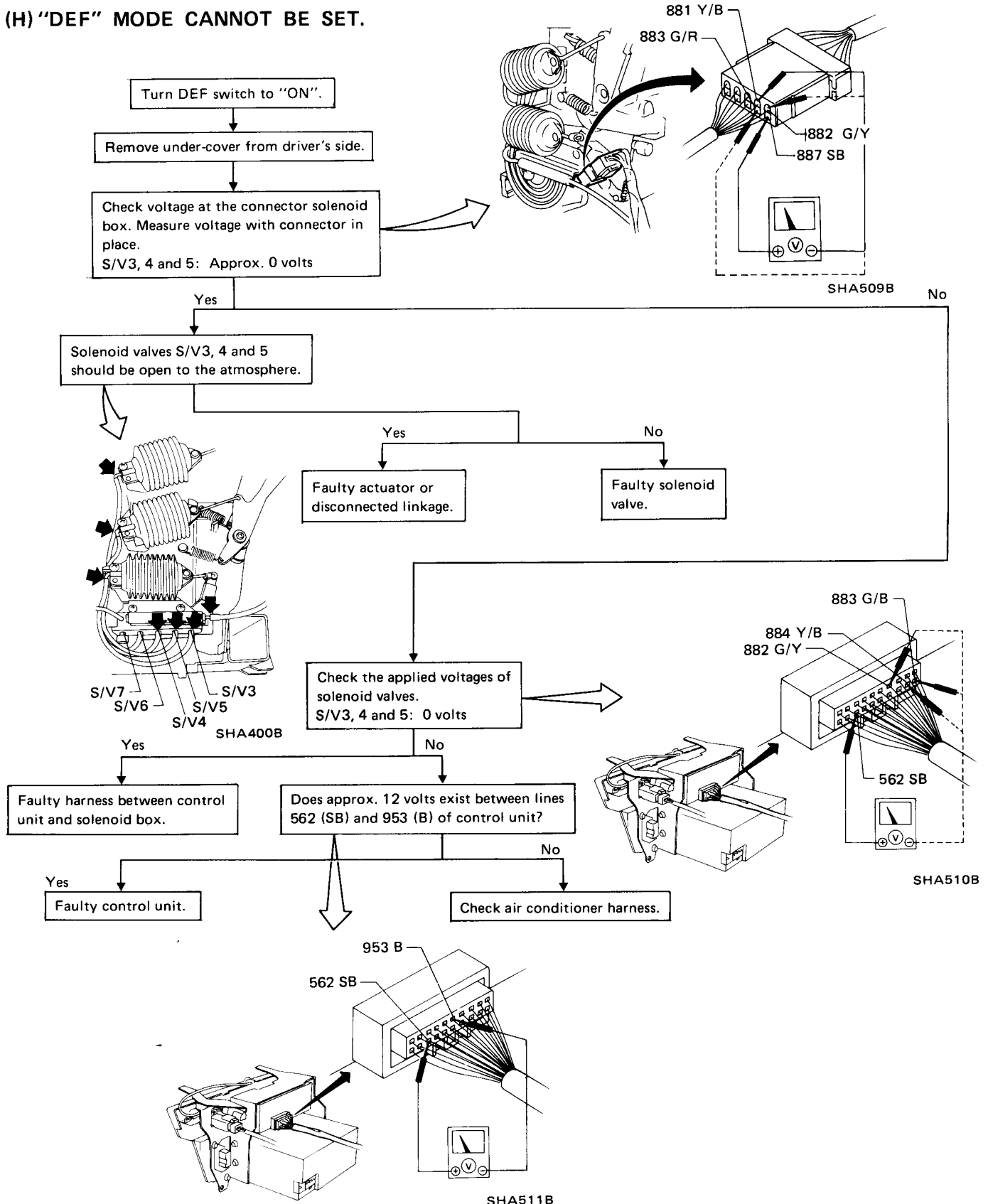

TROUBLE DIAGNOSES (Manual)

Trouble Diagnoses from Abnormal Conditions (Cont'd)

(I) OUTLET AIR WILL NOT BECOME WARM.

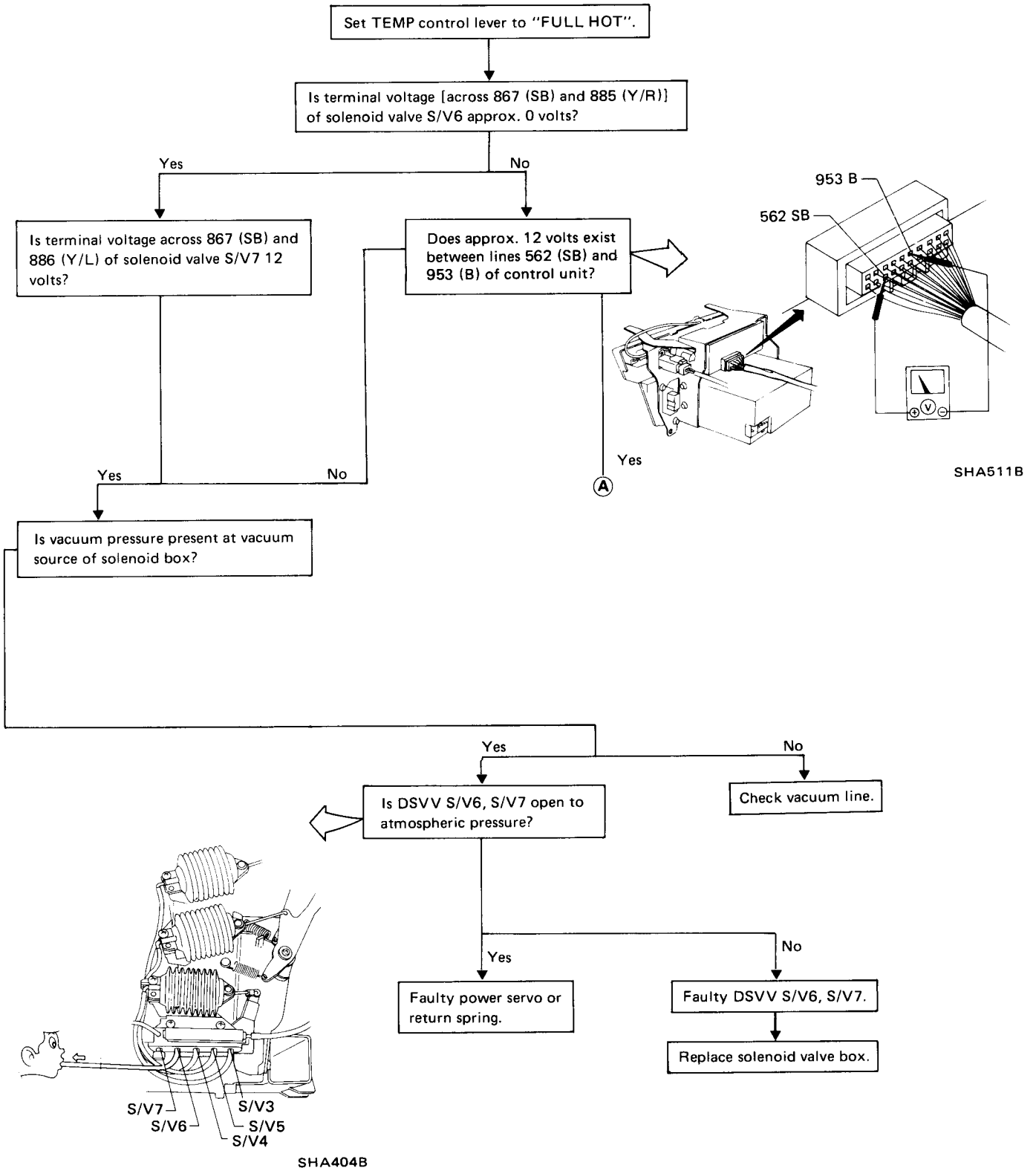

TROUBLE DIAGNOSES (Manual)

Trouble Diagnoses from Abnormal Conditions (Cont'd)

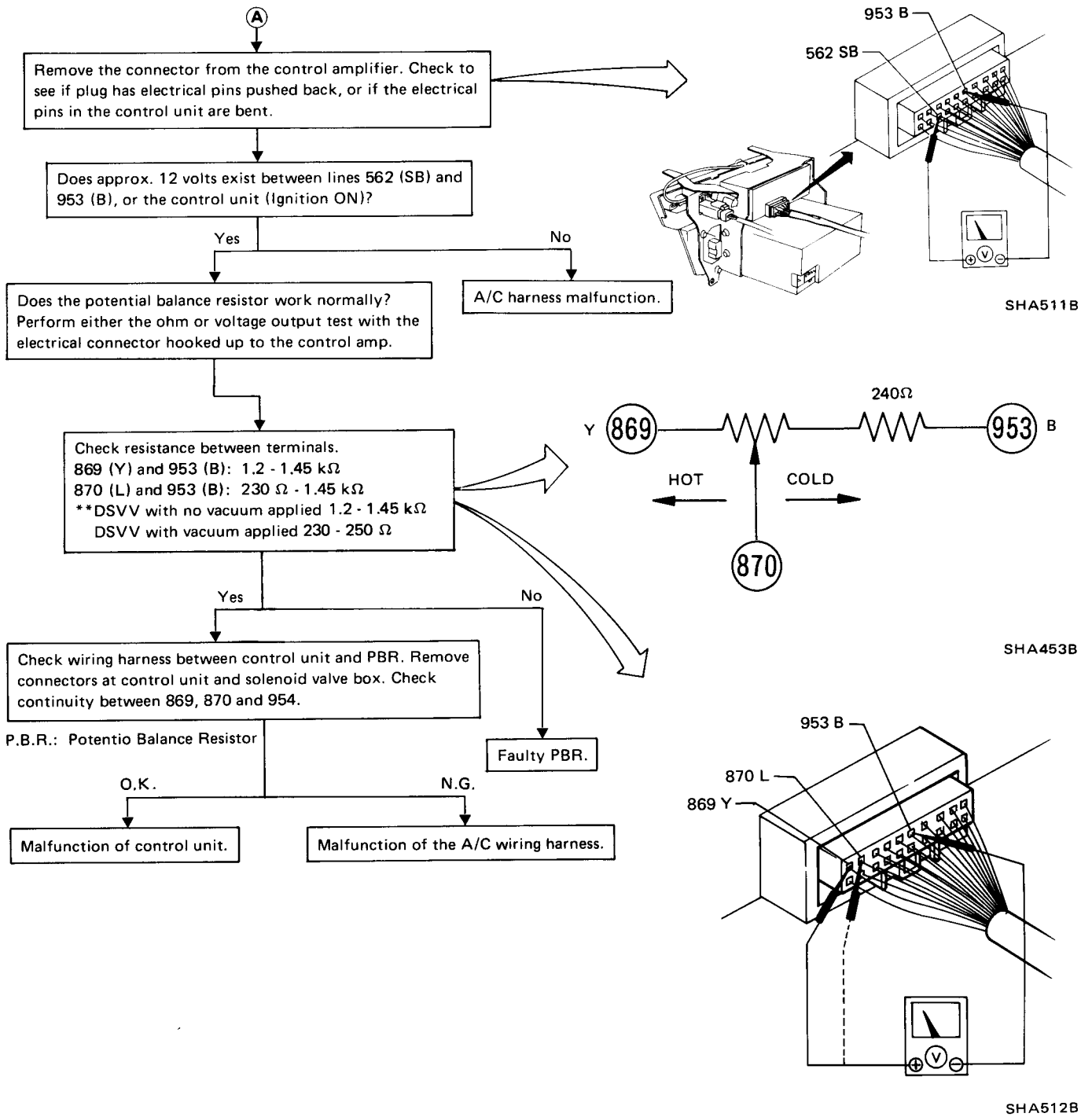

TROUBLE DIAGNOSES (Manual)

Trouble Diagnoses from Abnormal Conditions (Cont'd)

(J) OUTLET AIR WILL NOT BECOME COOL.

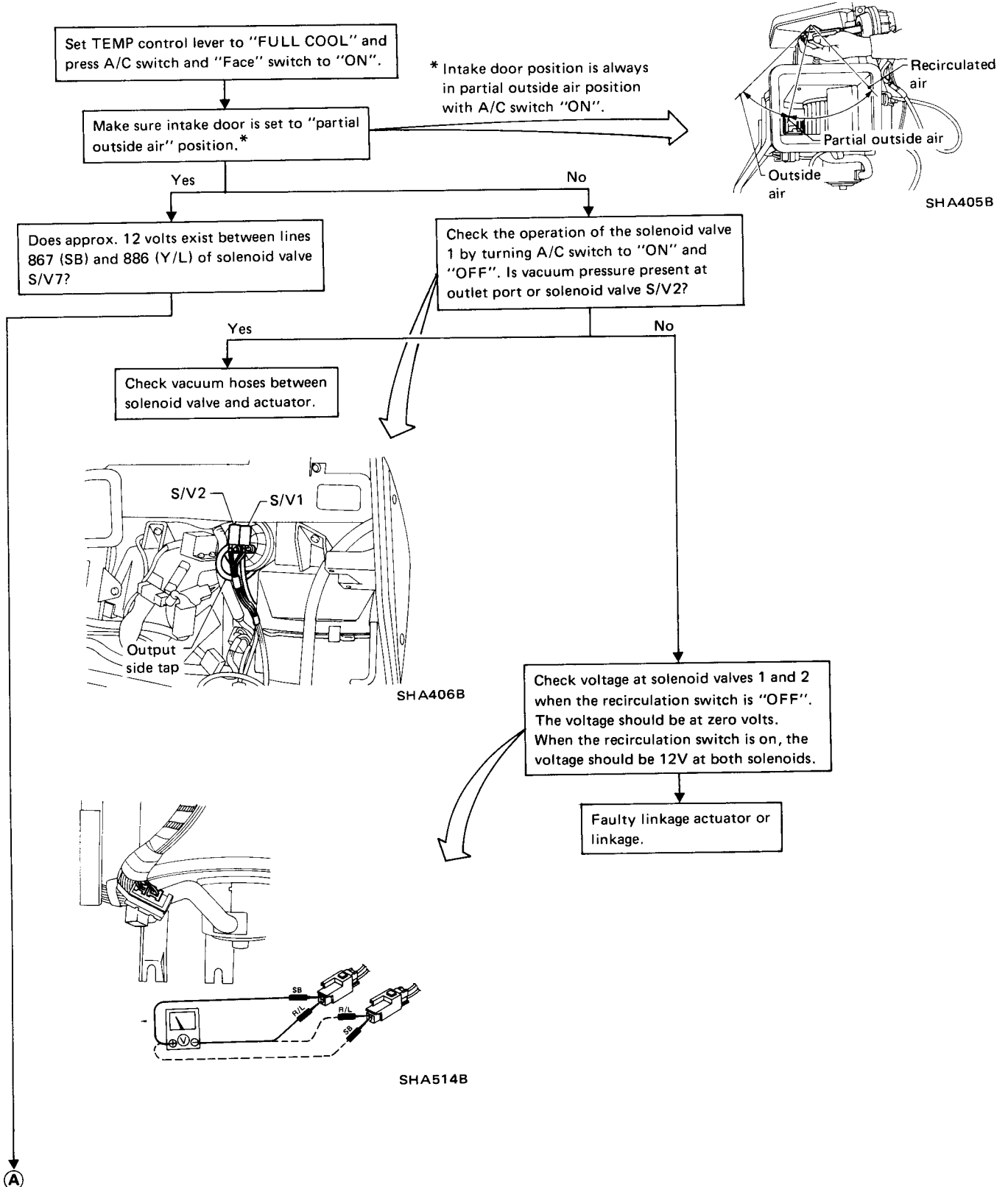

TROUBLE DIAGNOSES (Manual)

Trouble Diagnoses from Abnormal Conditions (Cont'd)

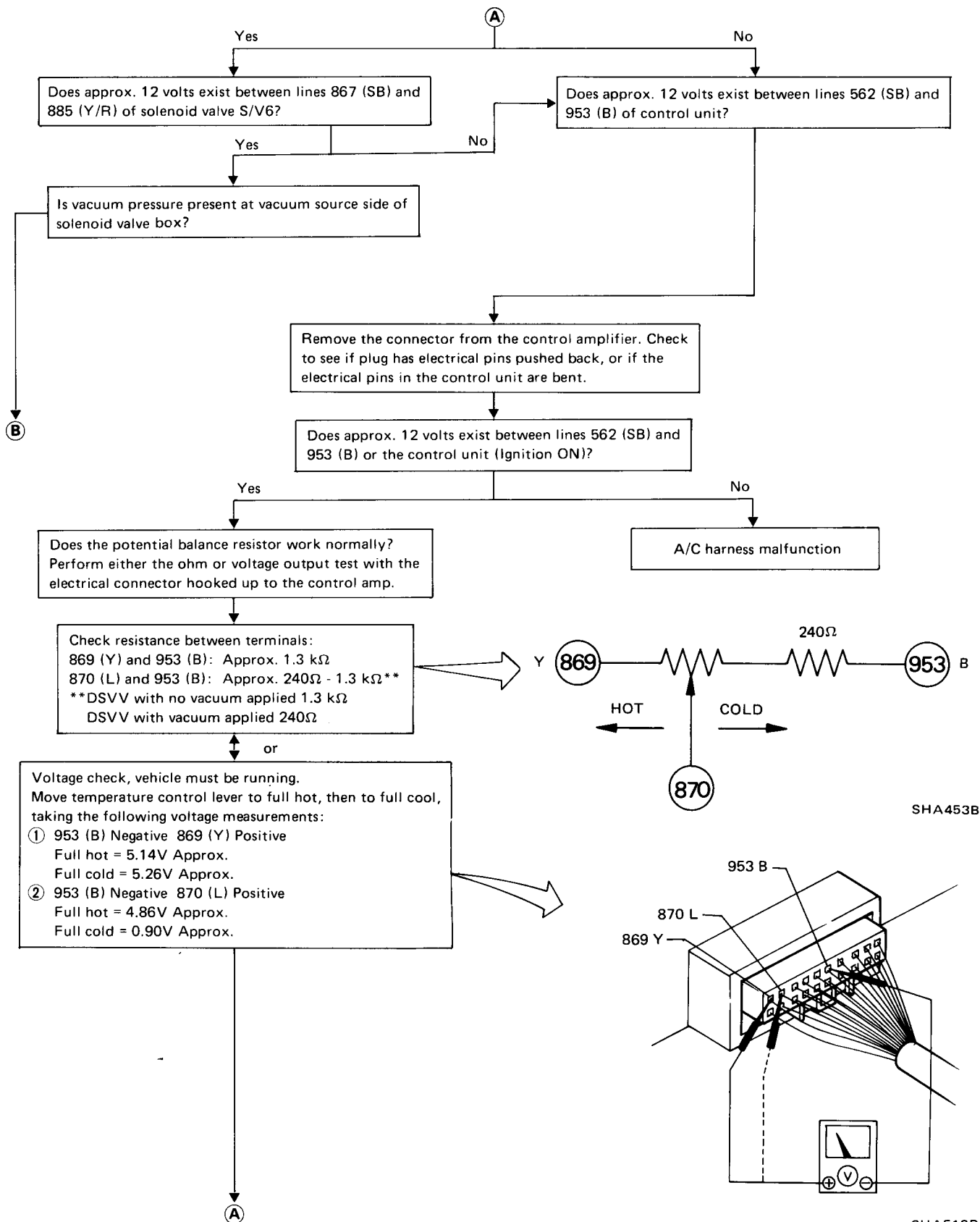

TROUBLE DIAGNOSES (Manual)

Trouble Diagnoses from Abnormal Conditions (Cont'd)

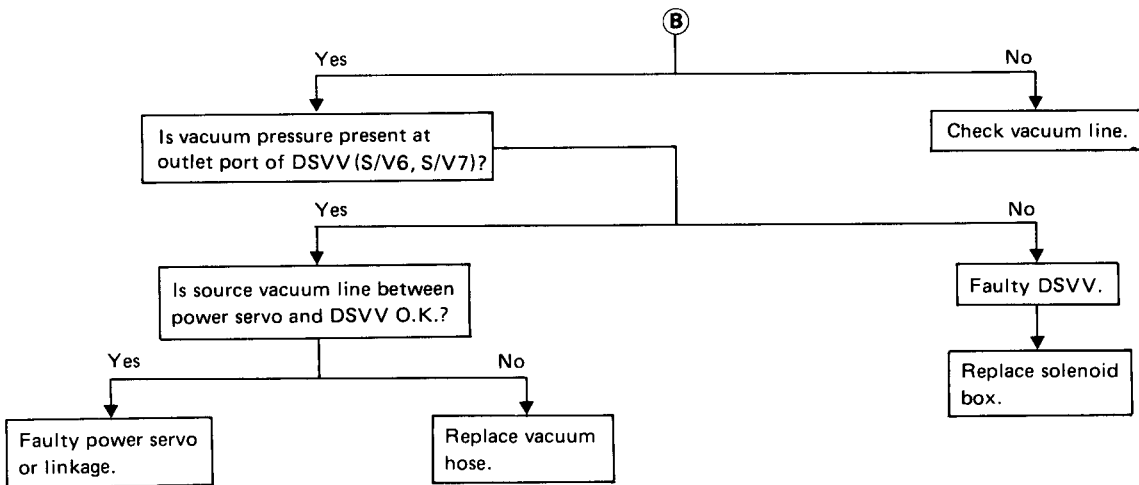
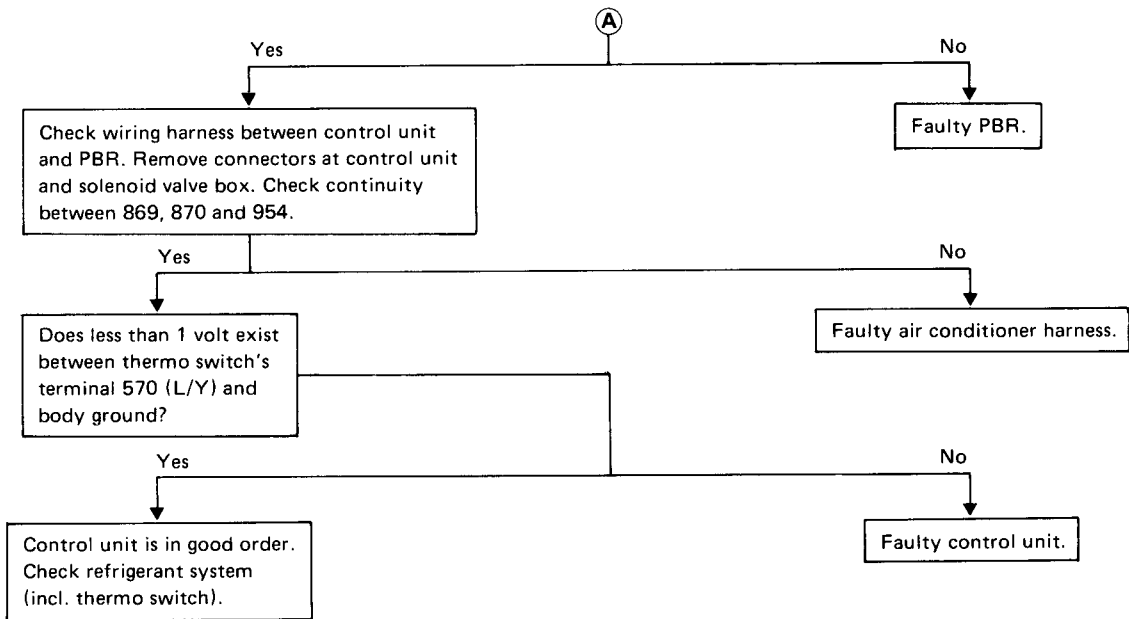

TROUBLE DIAGNOSES (Manual)

————— Trouble Diagnoses from Abnormal Conditions (Cont'd) —————

(K) OUTLET AIR TEMPERATURE CANNOT BE CHANGED WITH TEMP. CONTROL LEVER.

Refer to item (I) or (J) above to check and correct.

(L) MALFUNCTION OF WATER COCK OPERATION.

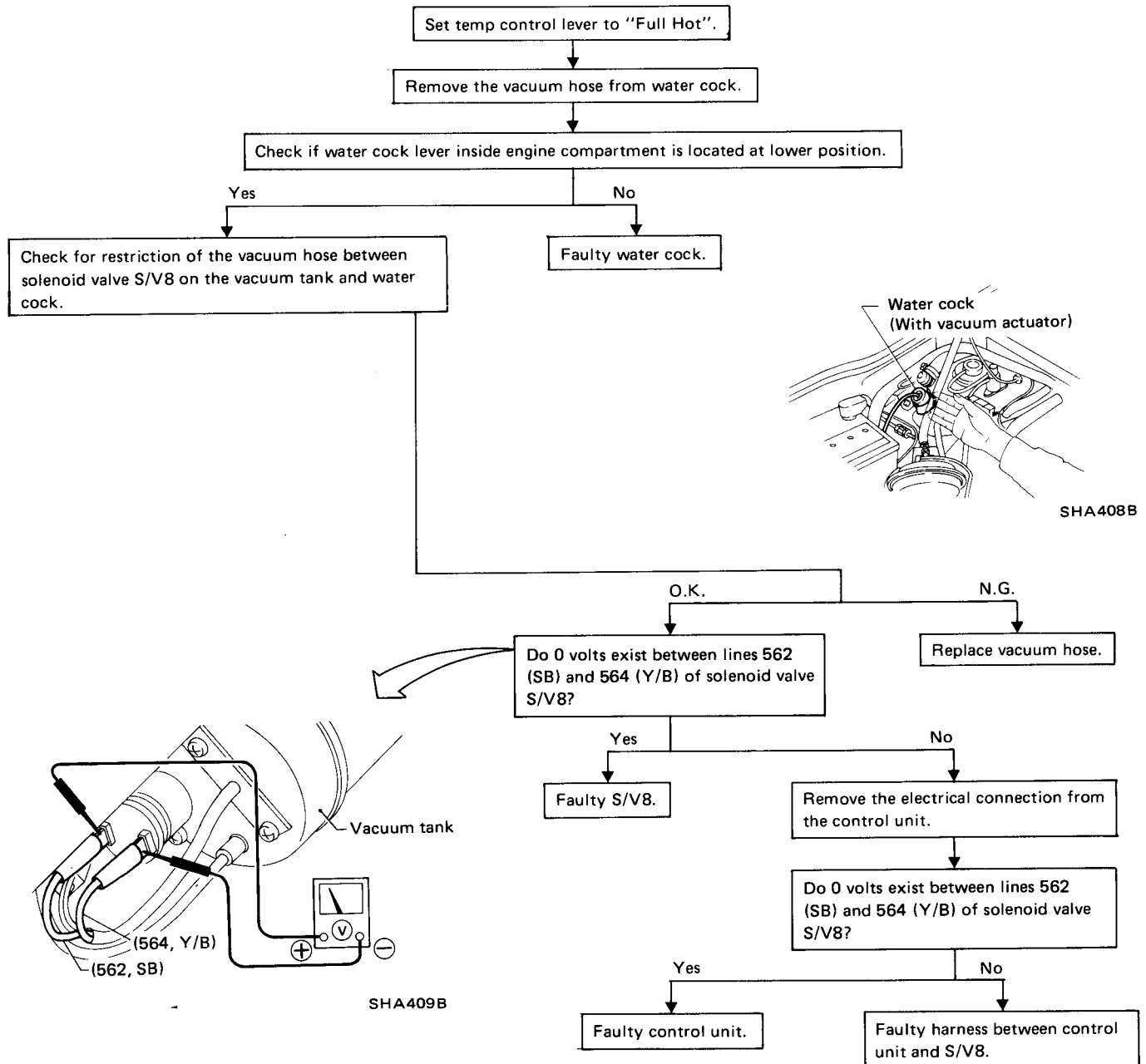

TROUBLE DIAGNOSES (Manual)

Trouble Diagnoses from Abnormal Conditions (Cont'd)

(M) OUTLET AIR TEMPERATURE FLUCTUATES.

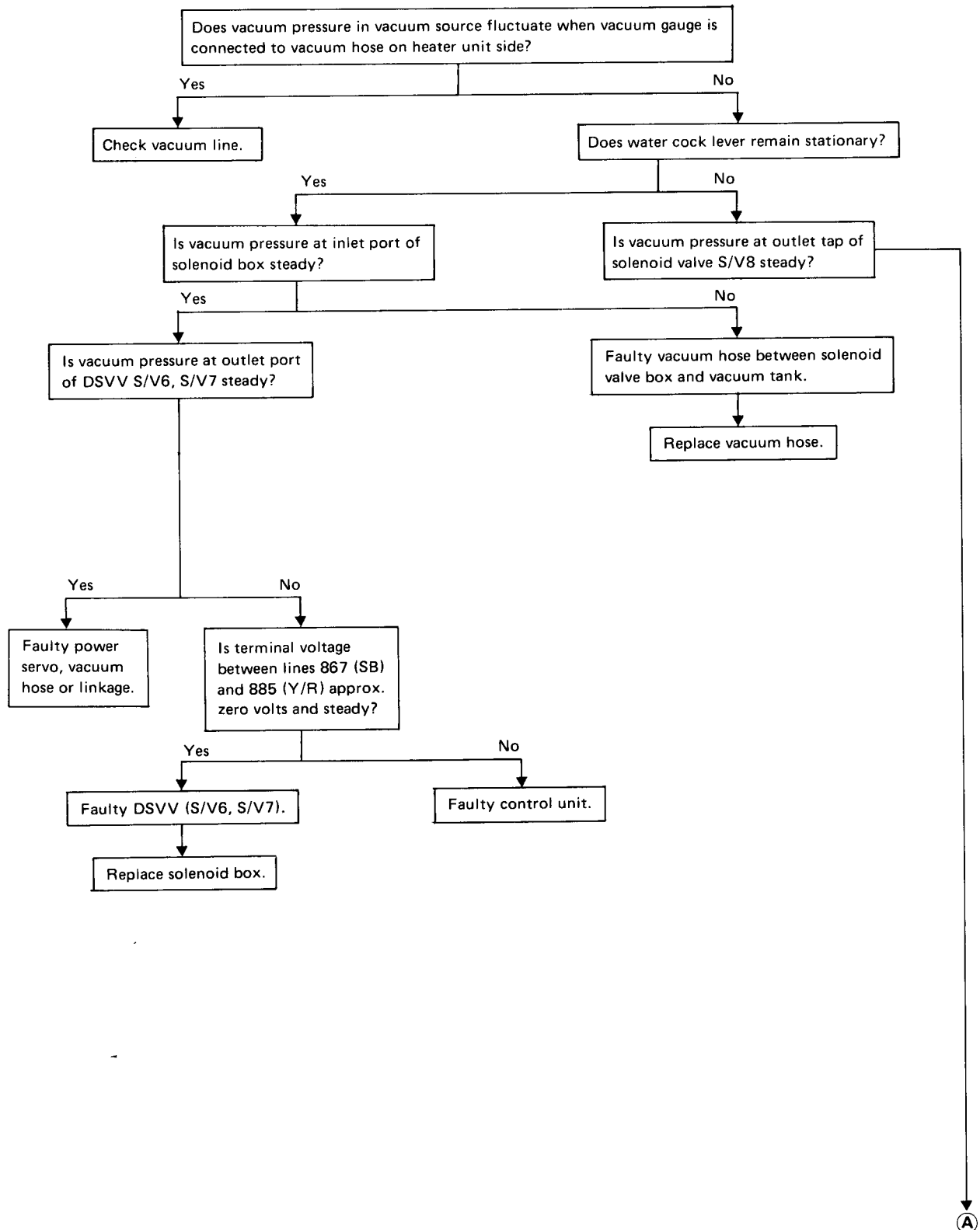

TROUBLE DIAGNOSES (Manual)

Trouble Diagnoses from Abnormal Conditions (Cont'd)

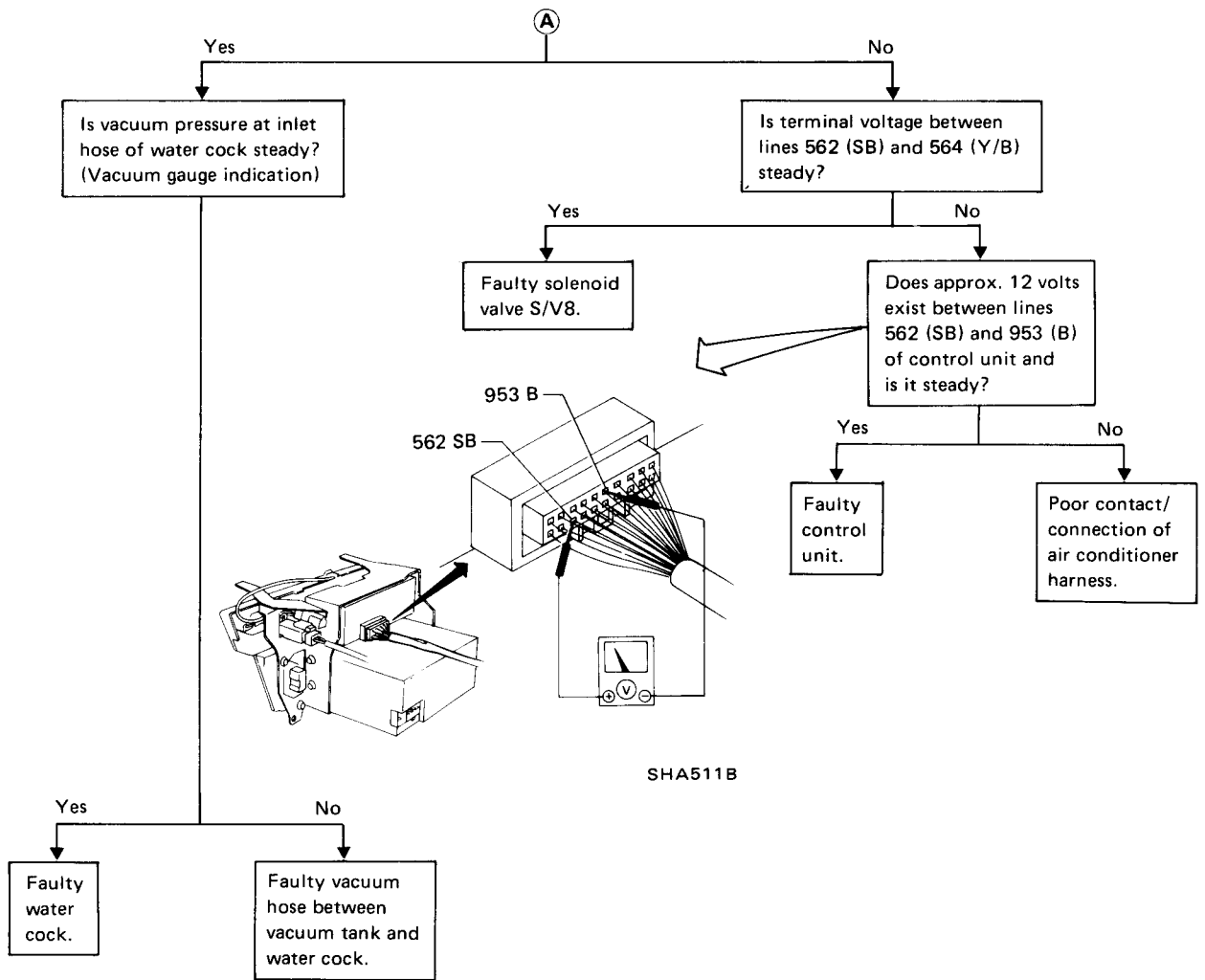

TROUBLE DIAGNOSES (Manual)

Trouble Diagnoses from Abnormal Conditions (Cont'd)

(N) RECIRCULATION MODE CANNOT BE SET WHEN "REC" SWITCH IS PRESSED.

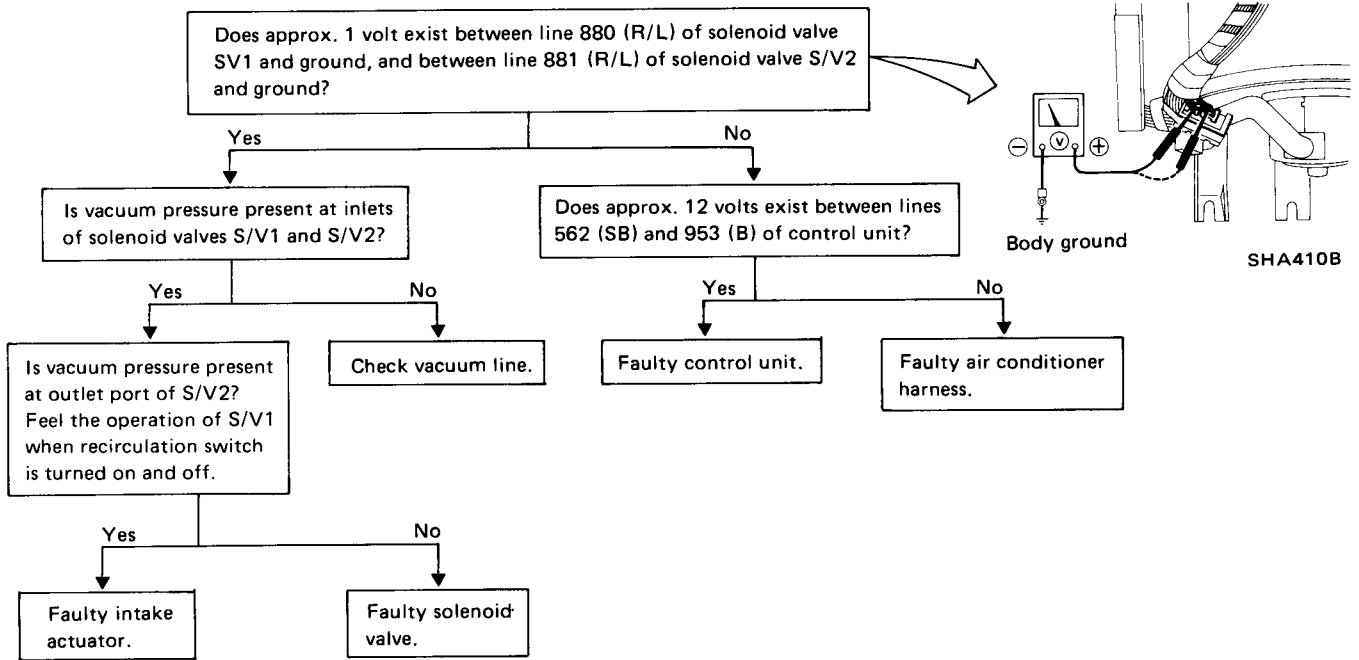

(P) OUTSIDE AIR IS NOT DRAWN INTO COMPARTMENT WHEN "REC" SWITCH IS TURNED OFF.

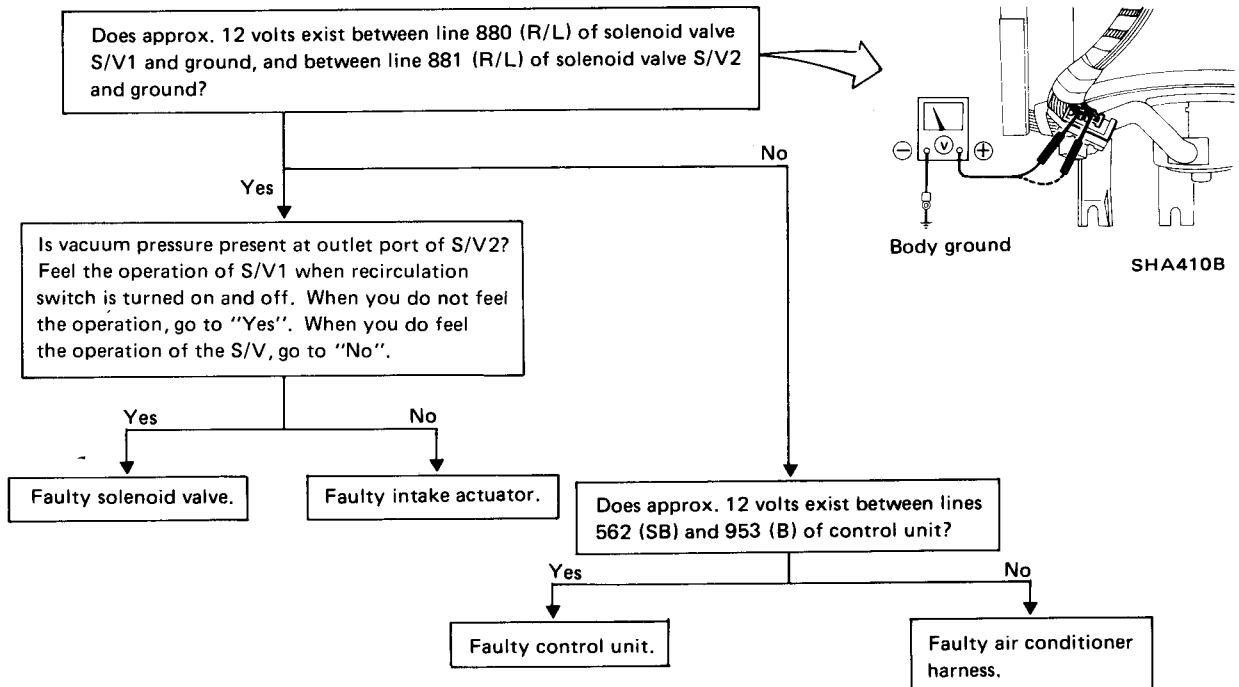

TROUBLE DIAGNOSES (Manual)

————— Trouble Diagnoses from Abnormal Conditions (Cont'd) —————

(Q) COMPRESSOR CLUTCH IS NOT ENGAGED.

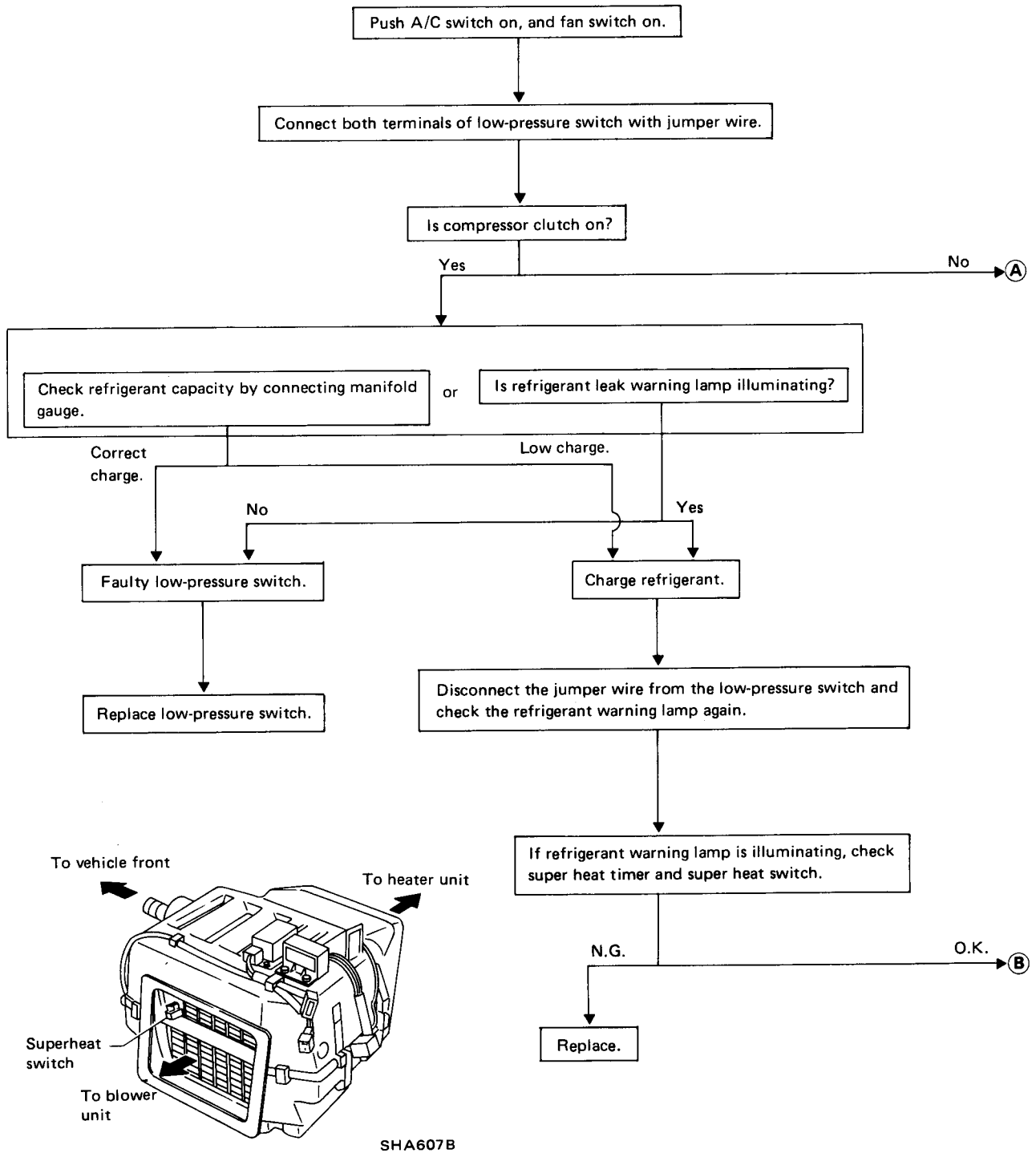

TROUBLE DIAGNOSES (Manual)

Trouble Diagnoses from Abnormal Conditions (Cont'd)

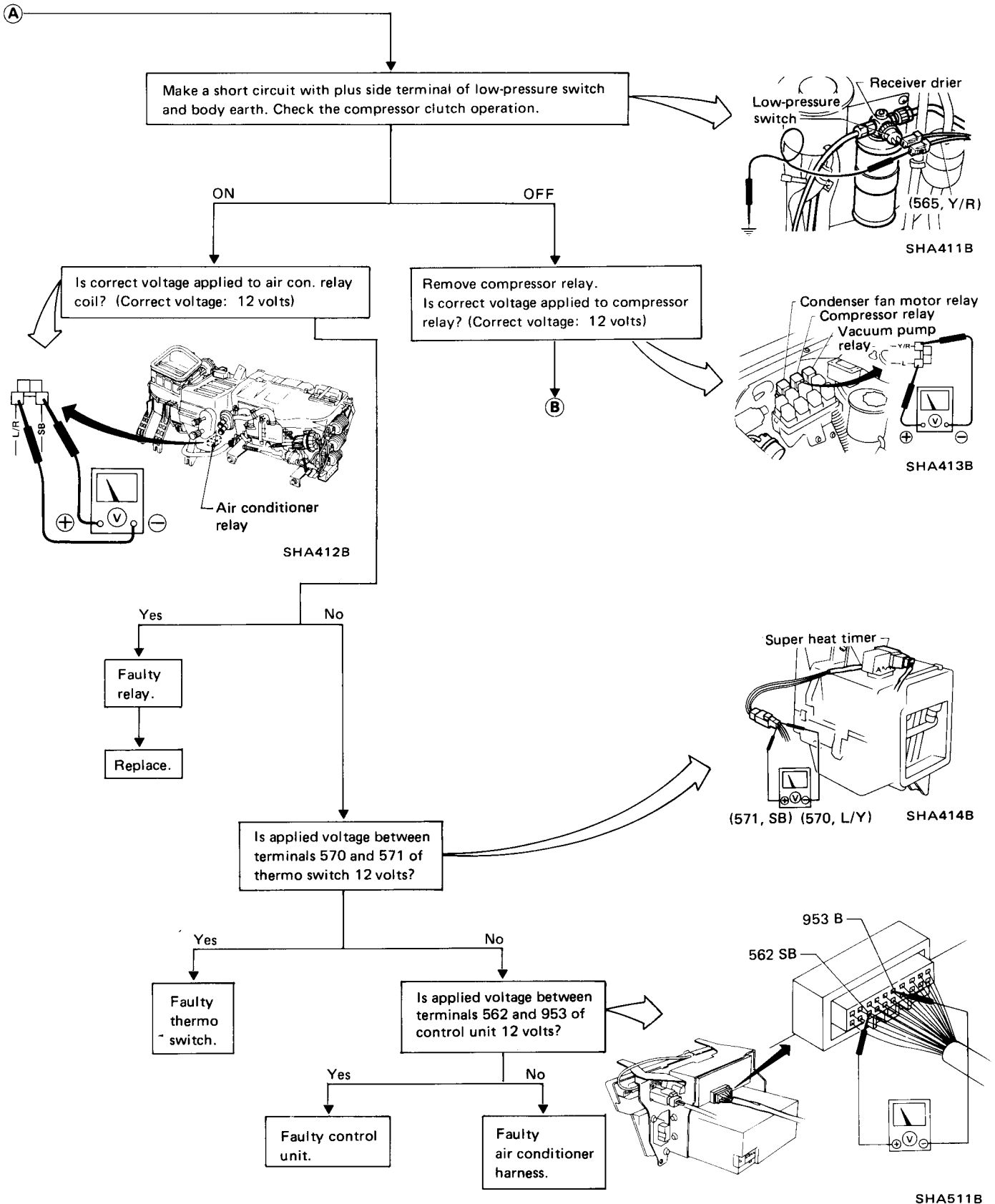

TROUBLE DIAGNOSES (Manual)

Trouble Diagnoses from Abnormal Conditions (Cont'd)

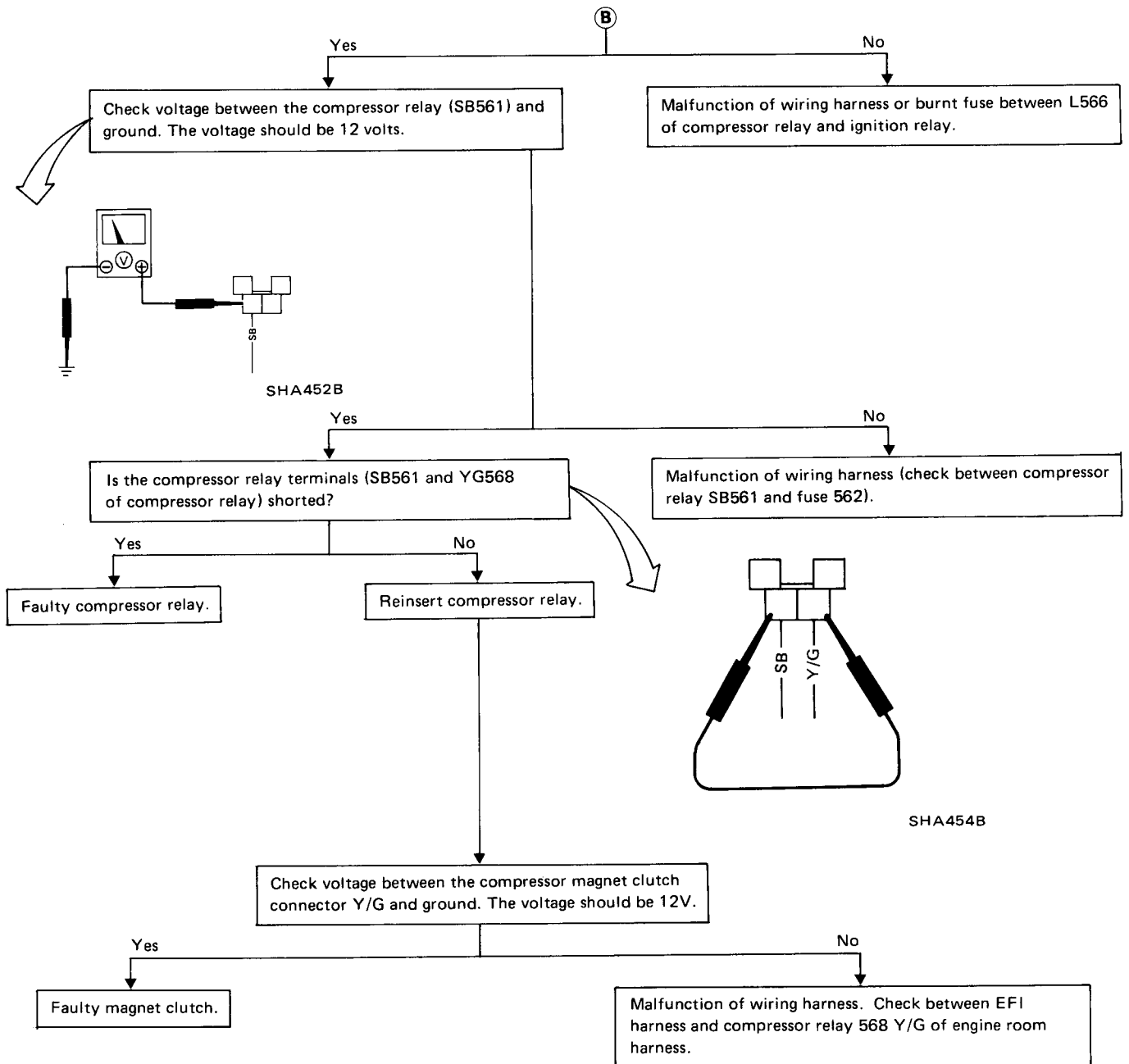

TROUBLE DIAGNOSES (Manual)

Trouble Diagnoses from Abnormal Conditions (Cont'd)

(R) MALFUNCTION OF F.I.C.D.

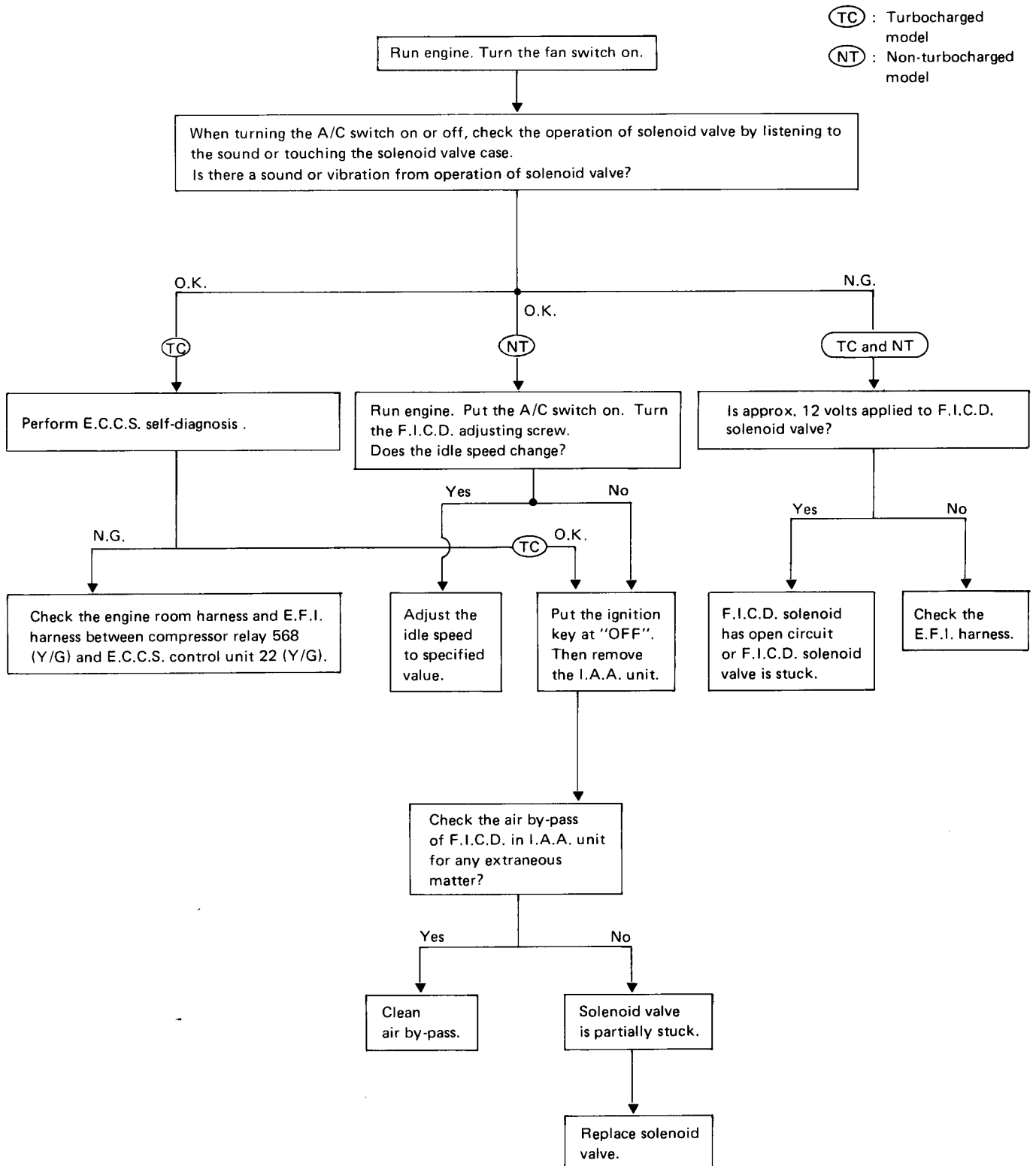

TROUBLE DIAGNOSES (Manual)

Trouble Diagnoses from Abnormal Conditions (Cont'd)

(S) BLOWER MOTOR ROTATES INTERMITTENTLY.

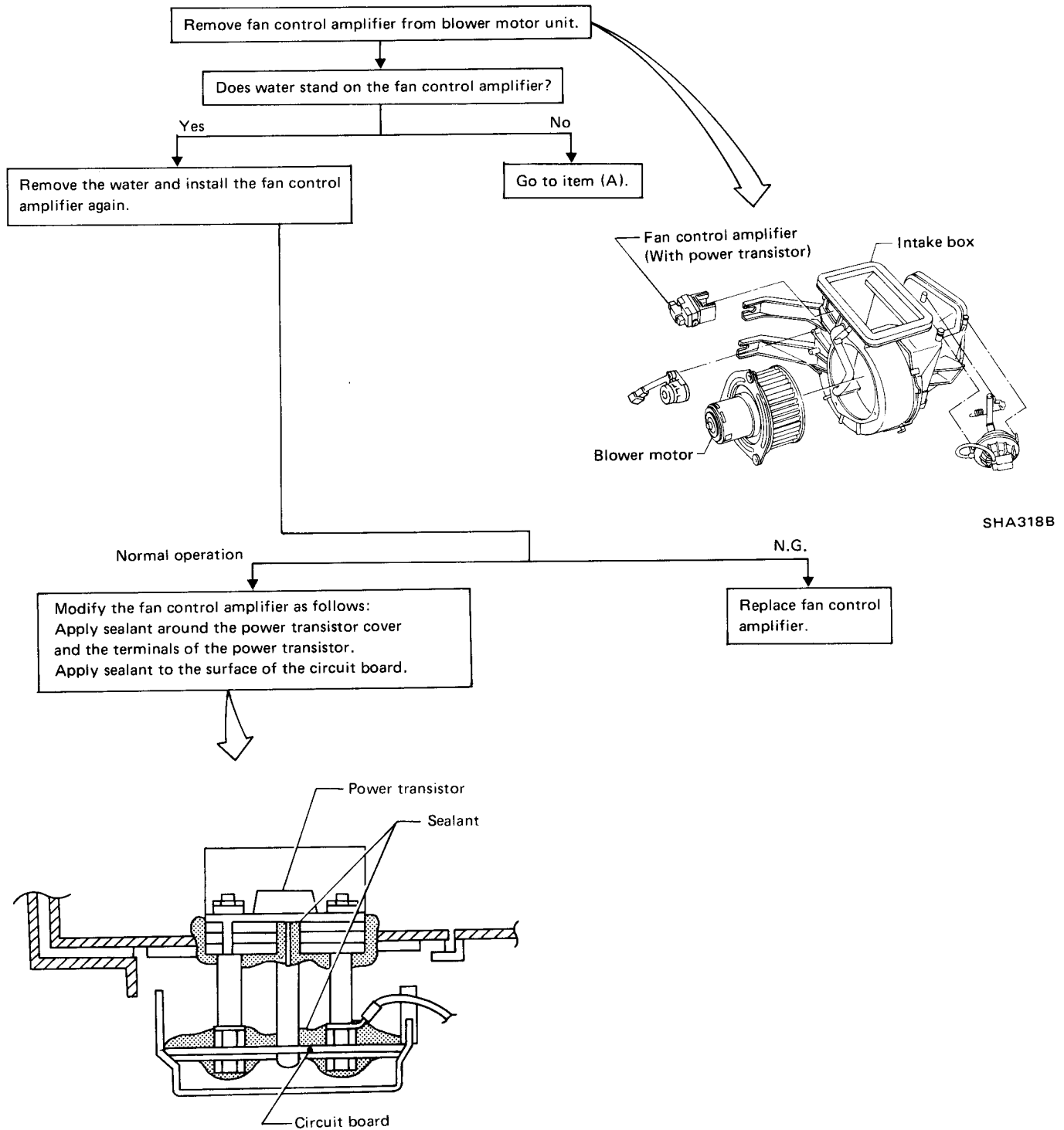

SHA318B

SHA521B

DESCRIPTION — Air Conditioner (Auto)

Features

- The vehicle sensors are installed at head level and foot level, in order to maintain the temperatures of both positions at the optimum levels.
- When starting the engine in cold weather, the system immediately operates in the defroster mode until the coolant temperature rises, thereby preventing fogging of the windshield.
- As the coolant temperature rises high enough to use the heater, the outlet door is automatically switched to the foot level for starting the heating operation. The system begins to control the air flow automatically as the outlet air temperature reaches the optimum level.
- When the DEF switch is ON, the air flow is automatically set to the "HI" position. However, the air flow can also be switched to "LO" by setting the manual switch to "LO" position.
- The objective temperature fine control switch (Set temp. adjuster) has been adopted. This switch permits adjustment of the upper objective temperature and the lower objective temperature within the range of $\pm 2^{\circ}\text{C}$ ($\pm 3.6^{\circ}\text{F}$).
- The manual DEF switch has been adopted so that the system can be fixed in the DEF mode for driving even when trouble occurs in the control function.
- The control unit display section (digital display and air flow indicator) is utilized for self-diagnosing each sensor and actuator.
- The proportional integral control system newly adopted in the temperature control system provides quick and accurate response without generation of steady-state error during stabilized operation.

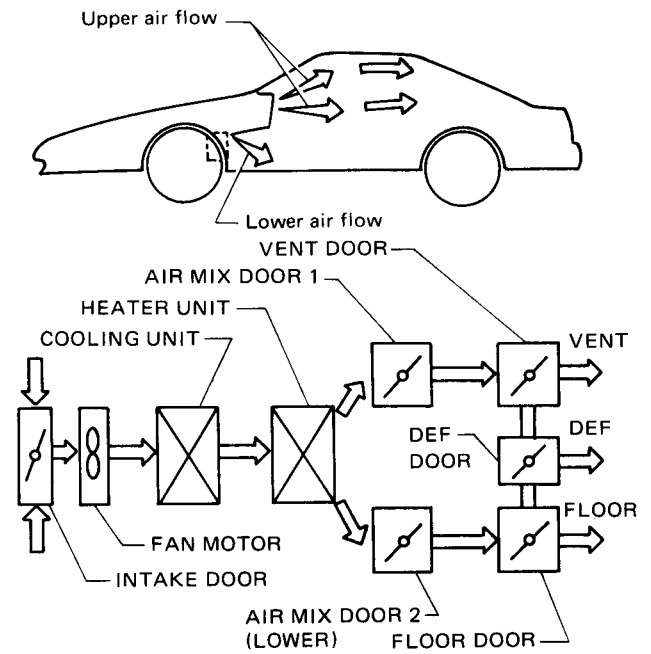

SHA336B

DESCRIPTION — Air Conditioner (Auto)

Refrigeration Cycle

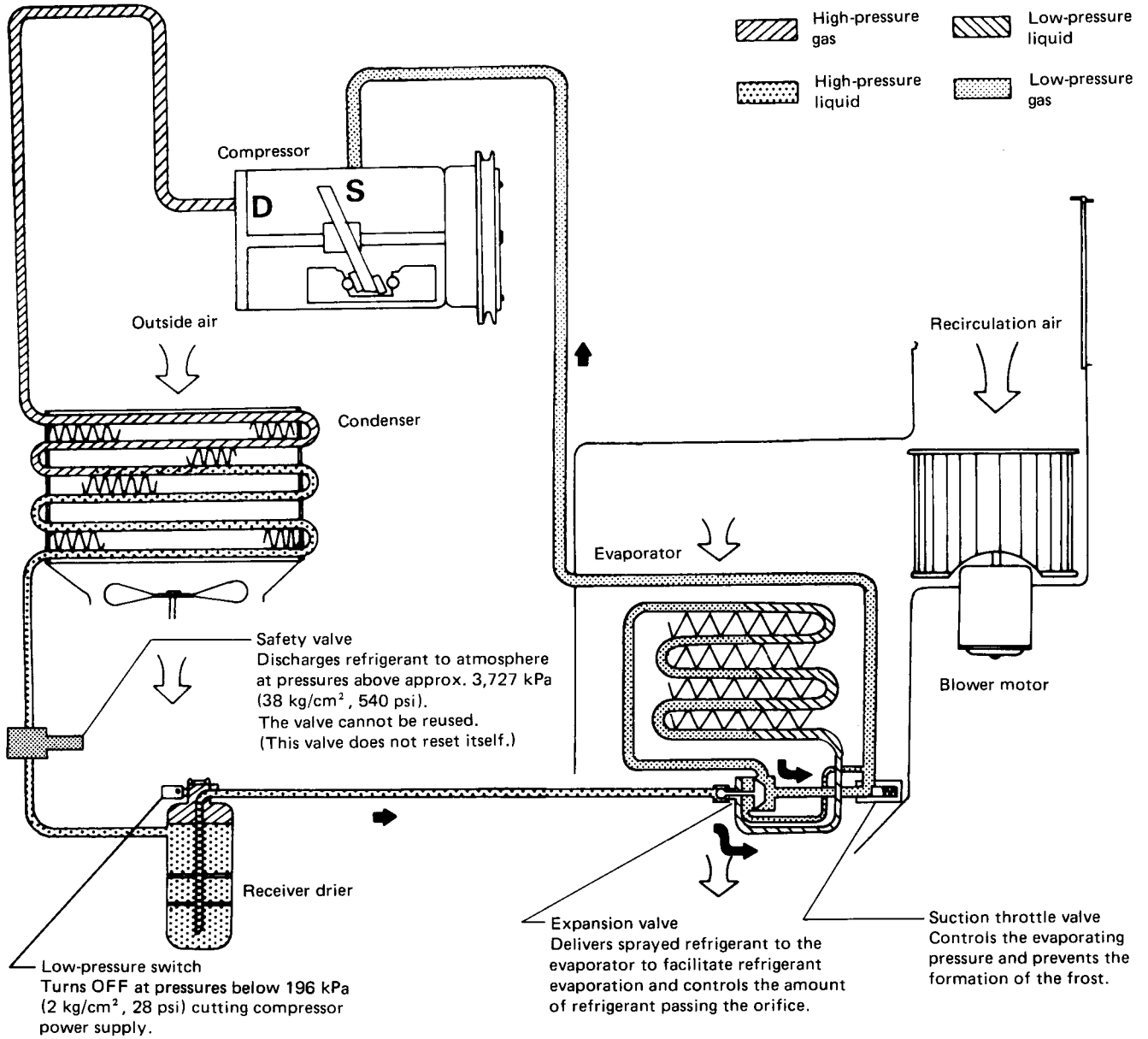

SHA276B

DESCRIPTION — Air Conditioner (Auto)

Function of the Switches on Control Unit

SET TEMP ADJUSTER	MANUAL DEF
As head, foot (Set minute temperature difference between upper and lower body)	Press to override automatic operation in case of system malfunction.

	DEF SWITCH	
	DEMIST	DEF
Intake door position	Automatic control	Outside air
Air flow volume	Automatic control	HI (MAX)
Outlet	DEF. and foot	Defroster
Compressor	ON [Outside air above 0°C (32°F)]	→
Outlet temperature	Automatic temperature fine-adjustment	Full hot

	AUTO SWITCH	
	ECONOMY	A/C
Intake door position	Outside air	Automatic control
Air flow volume	Automatic control	→
Outlet	Automatic control	→
Compressor	OFF	ON [Outside air above 0°C (32°F)]
Outlet temperature	Automatic temperature fine-adjustment	→

OFF SWITCH	OFF
Blower motor	OFF
Compressor	OFF
Intake door position	Outside air
Outlet	AUTO

Manual fan switch	
LO SWITCH	HI SWITCH
This switch fixes fan speed to low level.	
This switch fixes fan speed to high level.	

REC SWITCH

Selectable even at "OFF"

Only when pushing REC switch in "A/C" mode, "REC" mode will operate and last for ten minutes with its timer.

Temperature setting switch

Temperature higher

Temperature lower

Display of temperature indication

SET

Temperature setting indication

AMB

Ambient temperature indication

H

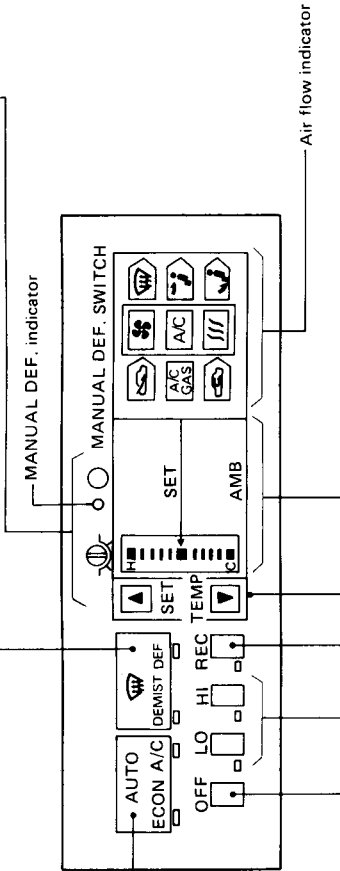

C



DESCRIPTION — Air Conditioner (Auto)

Basic Control Function and Control Switches

(3) SWITCHES AND THEIR CONTROL FUNCTIONS

Switch	Item to be controlled	Air flow	A/M door	Compressor	Water cock (W/C)	Intake air	Air outlet	Control When starting	Remarks
OFF		OFF	Auto	OFF	Auto	Outside air	Auto		Display (SET)/(AMB) is ON with ignition switch set to ACC. A/M door and W/C control air temperature obtained by ram pressure.
AUTO SW	A/C	Auto	Auto	ON [OFF below 0°C (32°F) amb. temp.]	Auto	Auto	Auto	Operated	A/C — ECON momentary switch (A/C has priority over ECON.)
	ECON	Auto	Auto	OFF	Auto	Outside air	Auto	Operated	
 SW	DEMIST	Auto	Auto	ON [OFF below 0°C (32°F) amb. temp.]	Auto	Auto	DEF and foot	Operated	DEF — DEMIST momentary switch (DEF has priority over DEMIST.)
	DEF	HI	Full-Hot	ON [OFF below 0°C (32°F) amb. temp.]	Open	Outside air	DEF	Not operated	HI indicator comes on. Selection of air flow at Lo is available.
Manual fan SW	Lo	Lo	—	—	—	—	—		Only air flow in Lo mode. All others are as determined by AUTO and  switches. When manual switch is pushed again, control function is cancelled.
	HI	HI	—	—	—	—	—		Only air flow in HI mode. All others are as determined by AUTO and  switches. When manual switch is pushed again, control function is cancelled.
REC		—	—	—	—	Inside air recirculation	—		REC function is activated by AUTO switch (A/C or ECON) and OFF. REC switch is provided with timer which cancels REC function 10 minutes after it has turned on.
MANUAL DEF		HI	Full-Hot	OFF	Open	Outside air	DEF		Pushing this switch again returns to previous condition.
SET TEMP ADJUSTER		—	—	—	—	—	—	—	Air temperatures at head and foot levels are adjustable to ±2°C (±3.6°F), regardless of operation of any other switch.

DESCRIPTION — Air Conditioner (Auto)

Display of the Air Flow Indicator

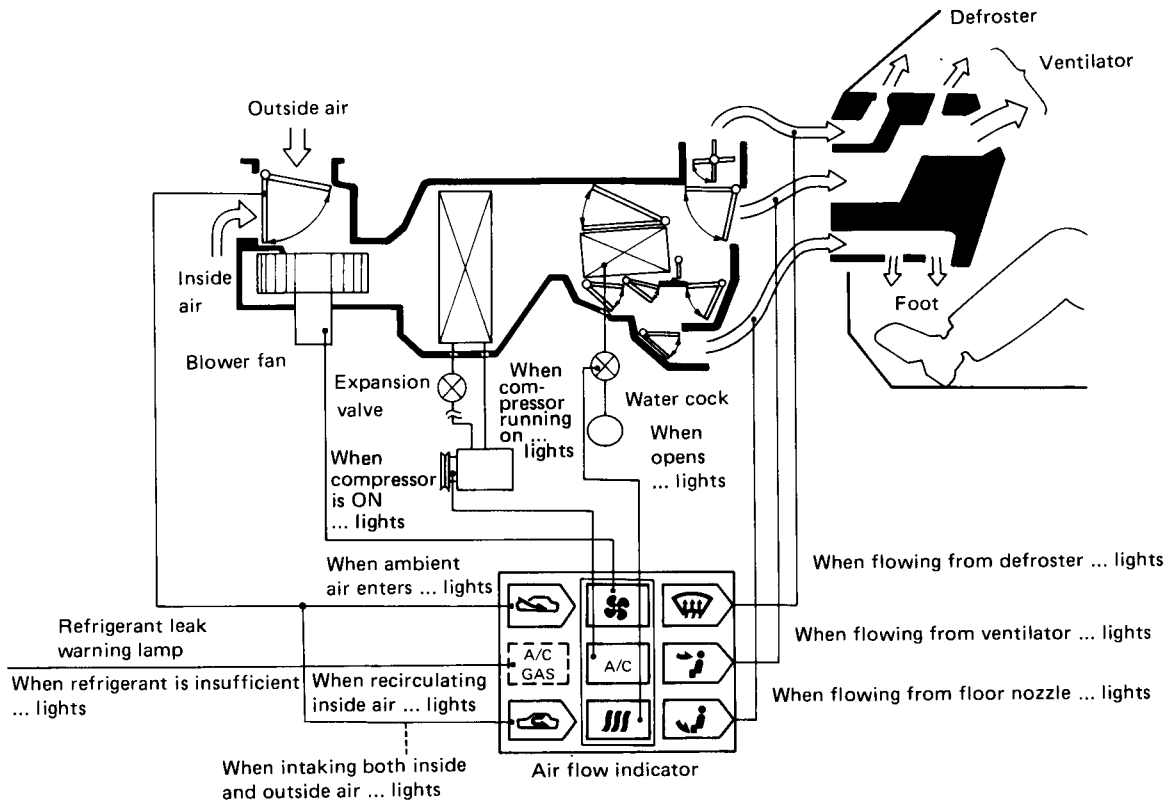

SHA283B

Display of Temperature Setting

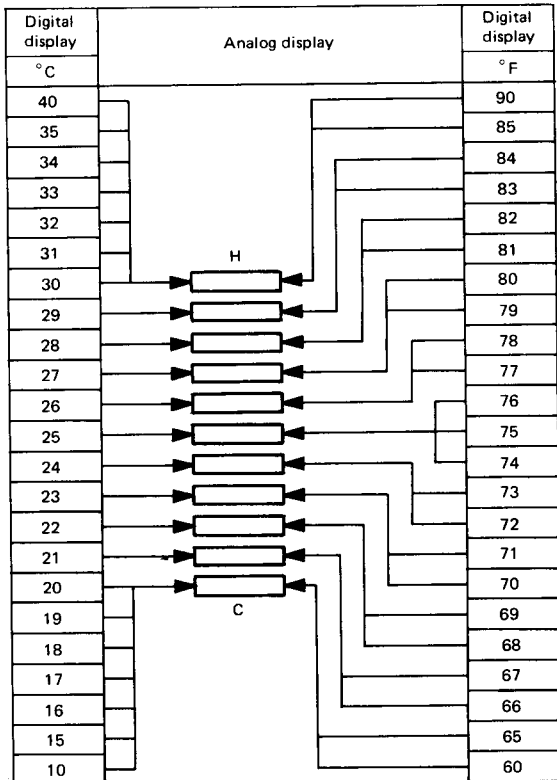

SHA523B

DESCRIPTION — Air Conditioner (Auto)

Control System

SENSOR & SWITCH LOCATION

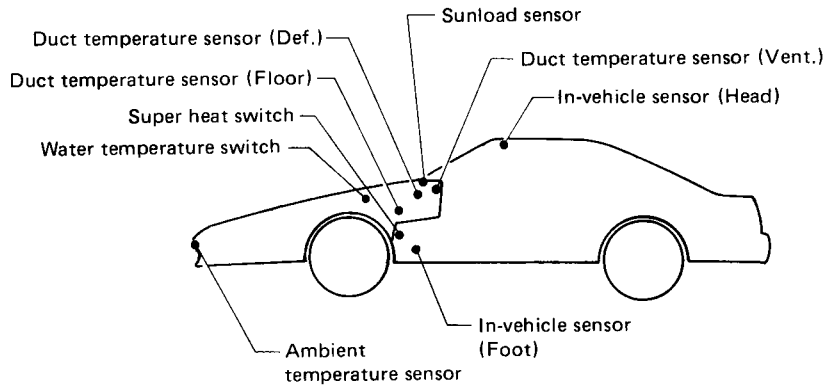

SHA337B

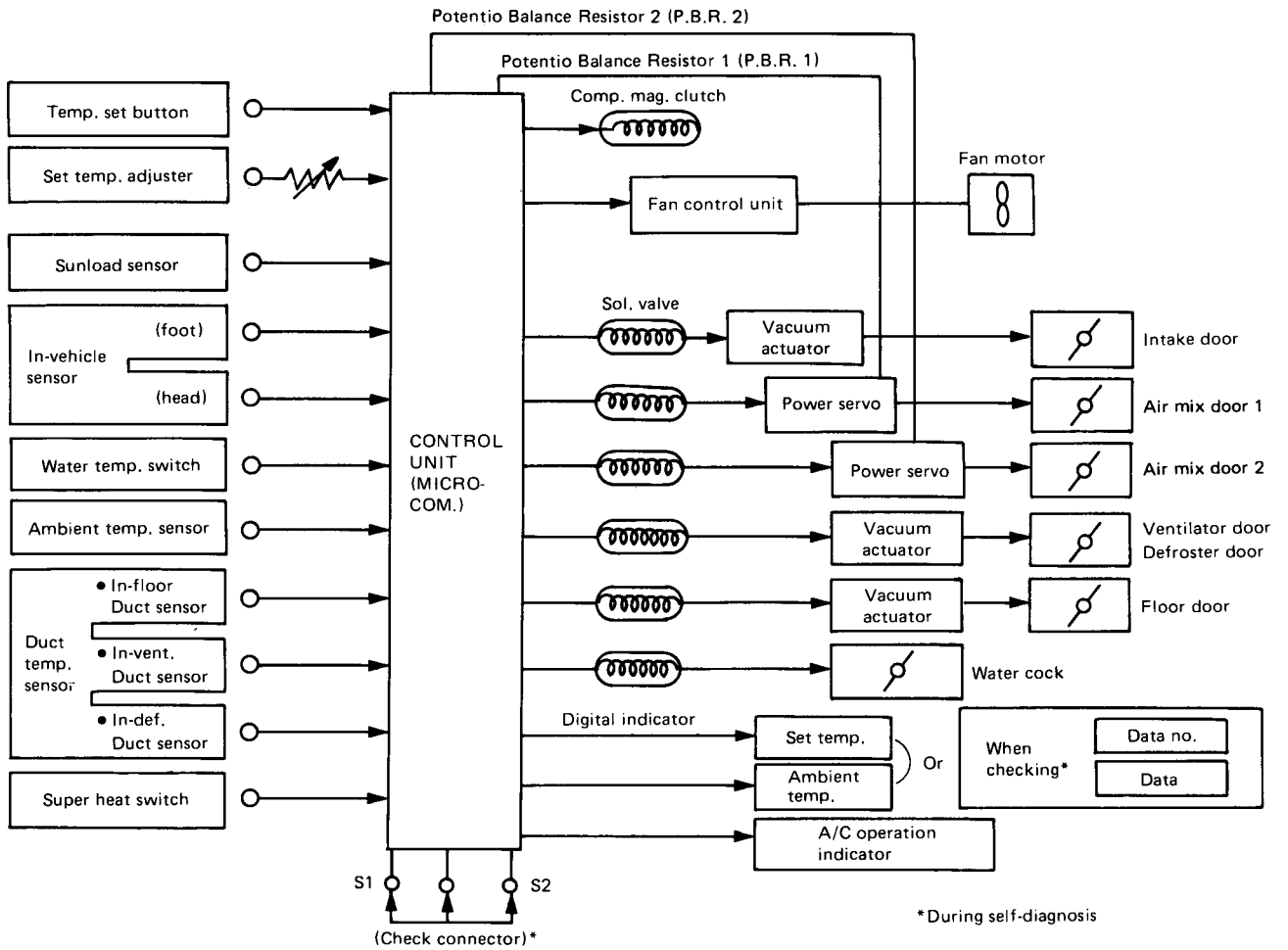

SHA338B

DESCRIPTION — Air Conditioner (Auto)

System Operation (Air mix door control)

AIR MIX DOOR CONTROL (Automatic temperature control)

1. Component parts

Air mix door control system consists of the parts shown below.

- 1) Automatic amplifier (with microcomputer)
- 2) Temperature setting switch
- 3) Two in vehicle sensors (head/foot)
- 4) Ambient temperature sensor
- 5) Three duct temperature sensors (defroster duct, ventilator duct, floor duct)
- 6) Sunload sensor
- 7) Power servo 1 and Power servo 2
- 8) PBR1 and PBR2
(P.B.R.: Potentio Balance Resistor)
- 9) D.S.V.V. 1 and D.S.V.V. 2
(D.S.V.V.: Double Solenoid Vacuum Valve)

• Automatic amplifier

This amplifier has a built-in microcomputer enabling it to deal with data and to provide precise control, which is necessary for driving the auto air conditioner system. In addition to the auto air conditioner mode, this microcomputer has a self-diagnosis mode program.

* For functioning of system for self-diagnosis of trouble, refer to "SELF-DIAGNOSING SYSTEM OF TROUBLE".

• Temperature setting switch

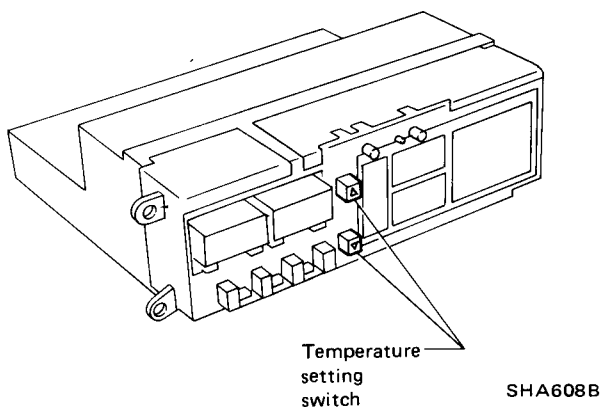

This switch is used for setting the in-vehicle temperature. Temperature set by the temperature setting switch is electrically memorized by the microcomputer in the automatic amplifier.

• In-vehicle sensor (Head, foot)

The in-vehicle sensor converts the temperature value of the inside air, which is drawn through (by low pressure) the aspirator fan, into a resistance value, which is then input into the auto amplifier. The sensor placed at head level detects the typical temperature at the upper half body level. The sensor placed at foot level detects the foot level temperature.

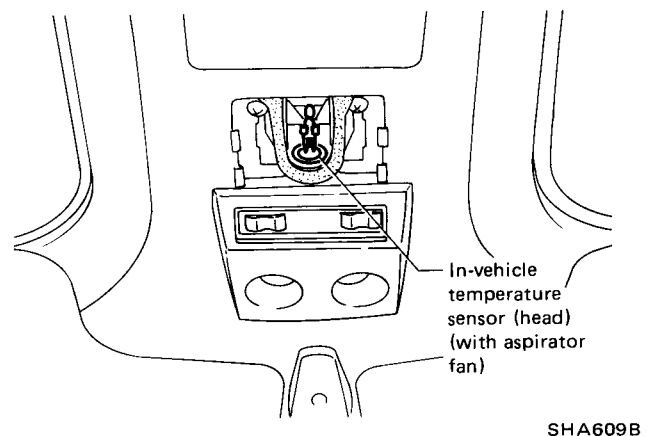
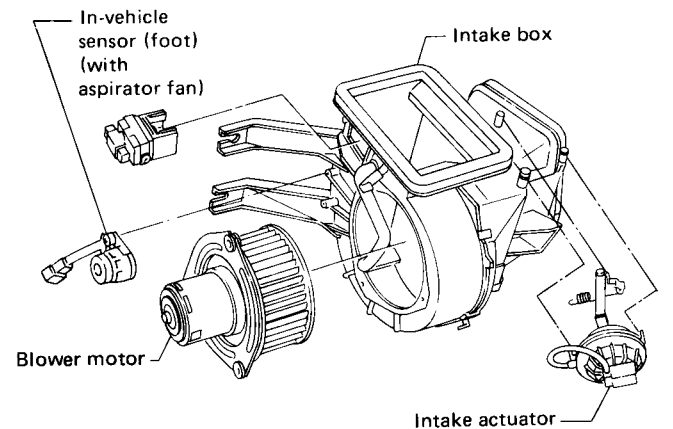

DESCRIPTION — Air Conditioner (Auto)

System Operation (Air mix door control) (Cont'd)

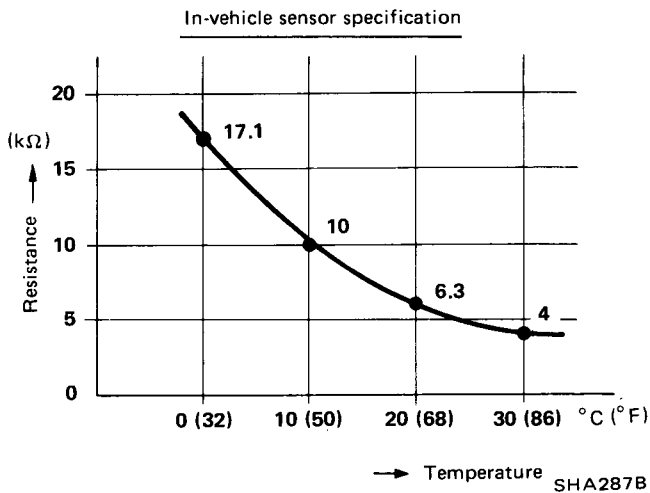

- **Ambient temperature sensor**

This sensor transforms the value of ambient temperature into a resistance value, which is put into the automatic amplifier.

(The specification of this sensor is the same as for the in-vehicle sensor.)

- **Defroster duct temp. sensor, ventilator duct temp. sensor, floor duct temp. sensor**

Each sensor transforms the value of outlet air temperature from each duct into a resistance value, which is put into automatic amplifier.

(The specification of these sensors is the same as for in-vehicle sensor.)

* For the location of these sensors, refer to **AIR FLOW AND COMPONENT LAYOUT — Auto A/C (Component Layout)**.

- **Sunload sensor (Photo diode)**

This sensor transforms sunload into current value, which is put into the automatic amplifier. This sensor is located in the defroster grille.

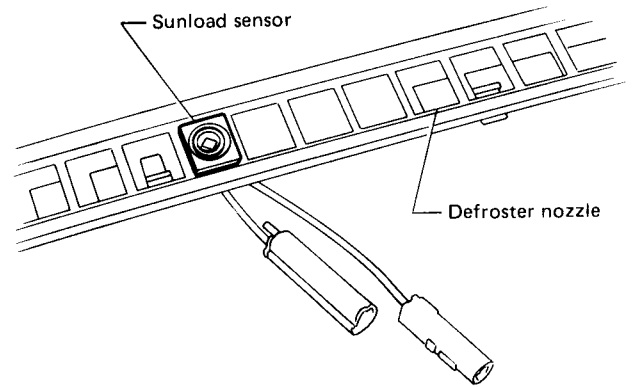

SHA299B

- **Power servo 1 & 2, P.B.R. 1 & 2**
(P.B.R.: Potentio Balance Resistor)

The power servo varies its stroke depending on the vacuum or atmospheric pressure led through the D.S.V.V. for controlling the air mix door. The P.B.R. is a variable resistor interlinked to the power servo, and the air mix door position (opening) information is input into the auto amplifier in terms of resistance value.

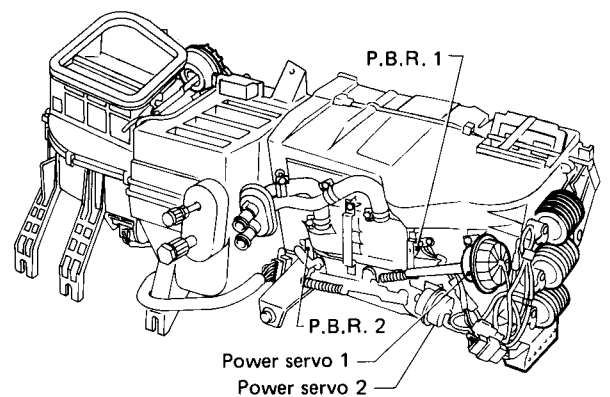

SHA319B

DESCRIPTION — Air Conditioner (Auto)

System Operation (Air mix door control) (Cont'd)

P.B.R. 1

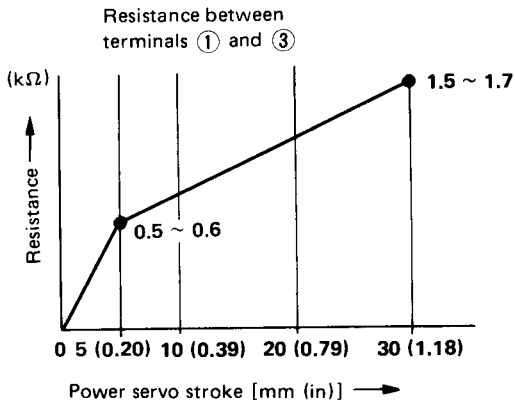

SHA610B

P.B.R. 2

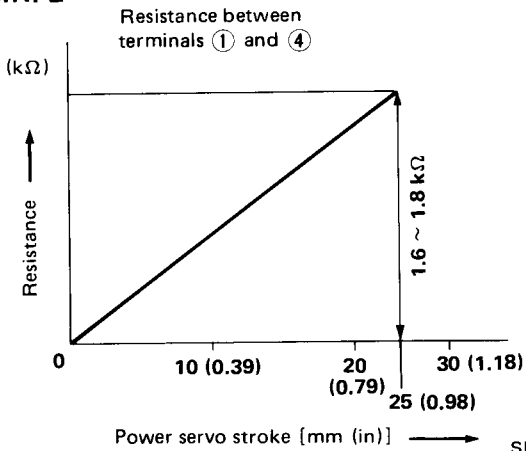

SHA301B

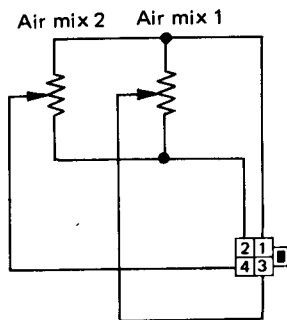

SHA611B

- D.S.V.V. (Double Solenoid Vacuum Valve)**
 D.S.V.V. can drive the power servo, because it transforms the electric signal from automatic amplifier into vacuum pressure or atmospheric pressure.

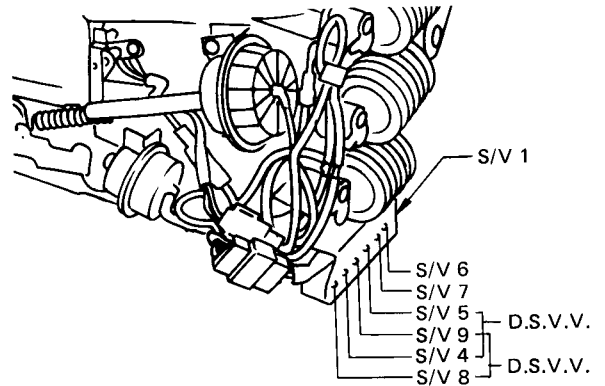

SHA339B

Inner structure of D.S.V.V.

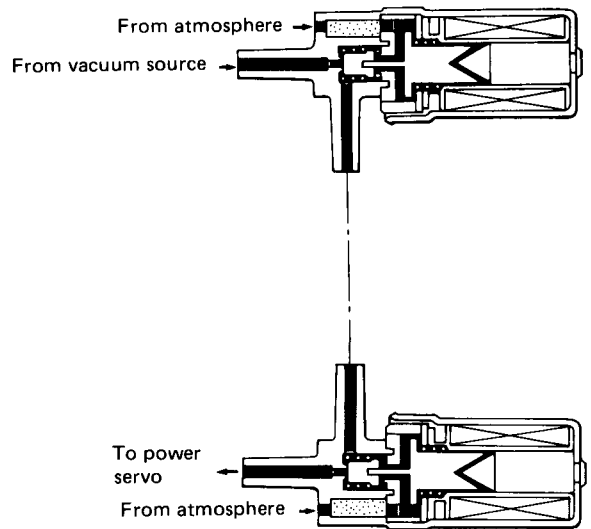

SHA289B

DESCRIPTION — Air Conditioner (Auto)

System Operation (Air mix door control) (Cont'd)

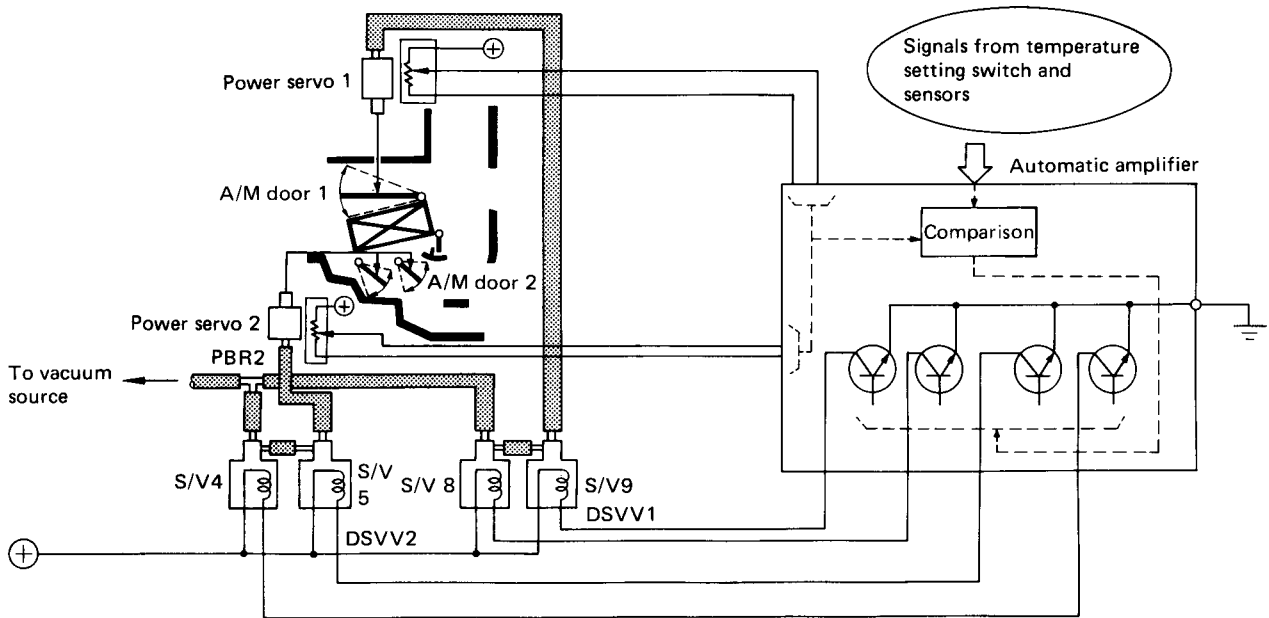

SHA288B

The objective air mix door opening calculated in the auto amplifier and the actual door opening input from P.B.R. are compared in the auto amplifier. A signal, as shown in the list is sent to D.S.V.V. according to the results of comparison.

CL: Solenoid valve is closed
OP: Solenoid valve is open

AIR MIX DOOR CONTROL

			HOT side	HOLD	COLD side
Air mix door 1	Operation of solenoid valve	S/V8	CL	CL	OP
		S/V9	OP	CL	OP
Air mix door 2		S/V4	CL	CL	OP
		S/V5	OP	CL	OP

DESCRIPTION — Air Conditioner (Auto)

System Operation (Air mix door control) (Cont'd)

2. System operation of air mix door control

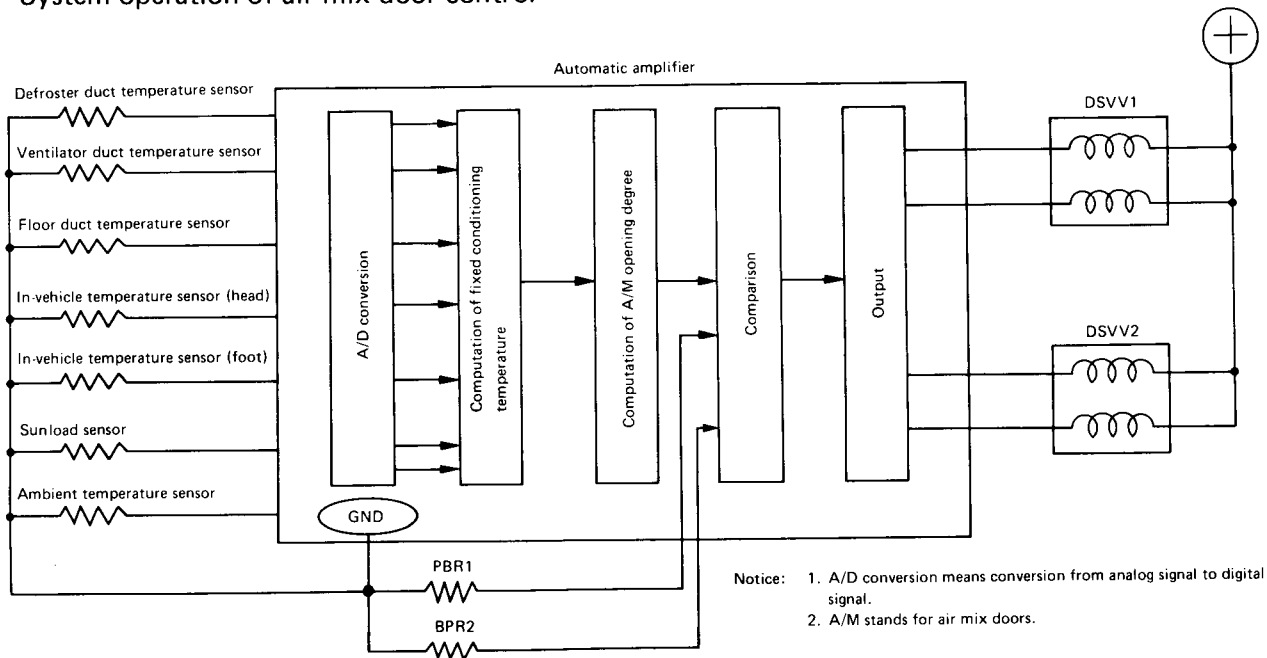

SHA290B

The temperature setting switch in this control system inputs the setting temperature signal to the auto amplifier.

The in-vehicle sensor, sunload sensor, ambient air temperature sensor, and duct temperature sensor also input the resistance value signals respectively to the auto amplifier corresponding to their conditions.

Receiving these input signals, the auto amplifier calculates the desirable air mix door position and causes the air mix door to move to the calculated position from its actual position detected by P.B.R. 1.

This movement of the air mix door is done by the power servo activated by the signal sent from the auto amplifier to the atmosphere side or vacuum side of the D.S.V.V.

The position of the air mix door is confirmed by the P.B.R. when converting the stroke of the power servo into voltage signal, and then by inputting the signal to the auto amplifier. The D.S.V.V. then continues operation until the air mix door position detected in this way coincides with the position determined by the control unit. The D.S.V.V. and the power servo stops operation once coincidence is attained.

DESCRIPTION — Air Conditioner (Auto)

System Operation (Intake door control)

INTAKE DOOR CONTROL

1. Component parts

The next parts are added to the component parts of air mix door control system.

- Intake door actuator

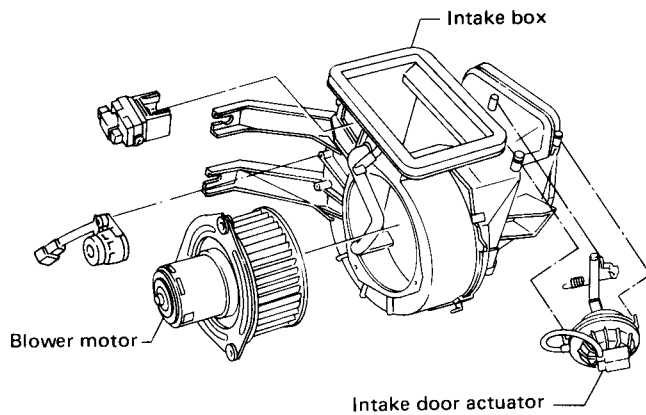

SHA318B

- Solenoid valve (Air valve type)

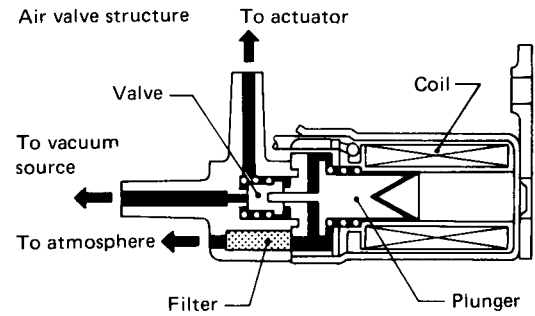

	Vacuum source	Actuator side	Atmosphere side
SW			
ON	○	○	
OFF		○	○

SHA302B

2. System operation of intake door control

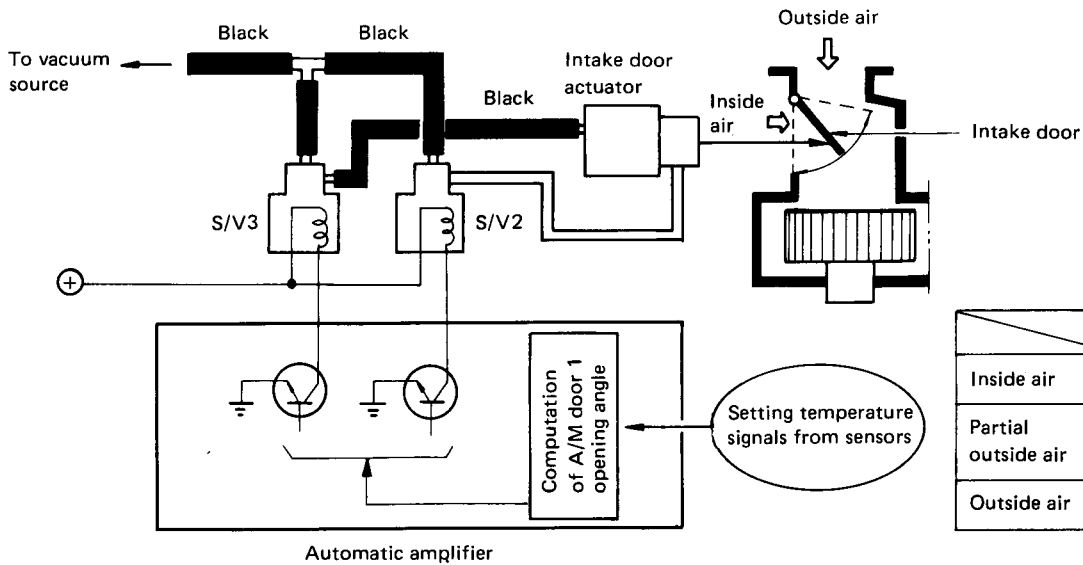

	S/V3	S/V2
Inside air	OPEN	OPEN
Partial outside air	CLOSED	CLOSED
Outside air	CLOSED	CLOSED

SHA303B

DESCRIPTION — Air Conditioner (Auto)

System Operation (Intake door control) (Cont'd)

The intake door is switched in order to introduce the inside air, partial outside air, or outside air at the positions already memorized in the auto amplifier corresponding to the angle (opening) of the air mix door 1 which is automatically temperature controlled. The relationship between the angle (opening) of the air mix door and the intake door position is as shown below.

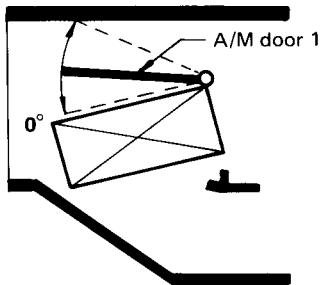

SHA304B

Condition 1: Outside temperature is 10°C (18°F) higher than set temperature

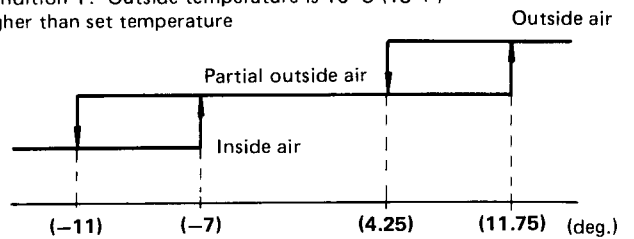

A/M door 1 angle (Opening angle): setting value

Condition 2: Except for Condition 1

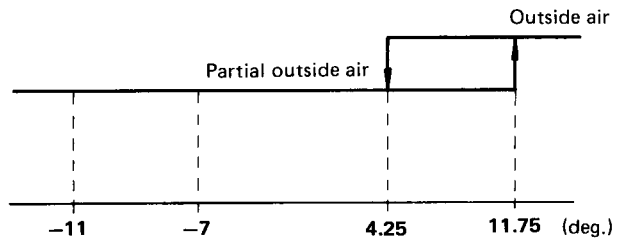

A/M door 1 angle (Opening angle): setting value.

SHA305B

System Operation (Outlet door control)

OUTLET DOOR CONTROL

1. Component parts

Outlet door control system consists of the parts shown below.

- 1) Defroster door actuator
- 2) Ventilator door actuator
- 3) Defroster and floor door actuator
- 4) Solenoid valve 6, 7
- 5) Sunload sensor
- 6) Ambient temperature sensor
- 7) Automatic amplifier

● Actuators

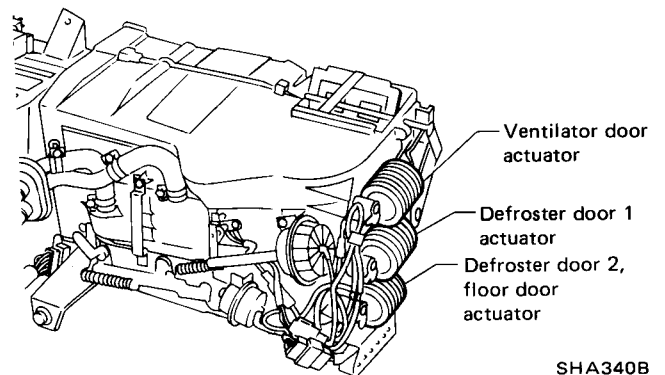

SHA340B

● Solenoid valve 6, 7

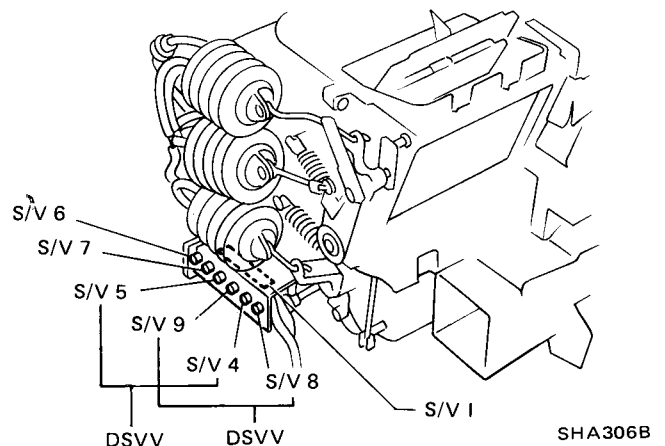

SHA306B

DESCRIPTION — Air Conditioner (Auto)

System Operation (Outlet door control) (Cont'd)

2. System operation of outlet door control

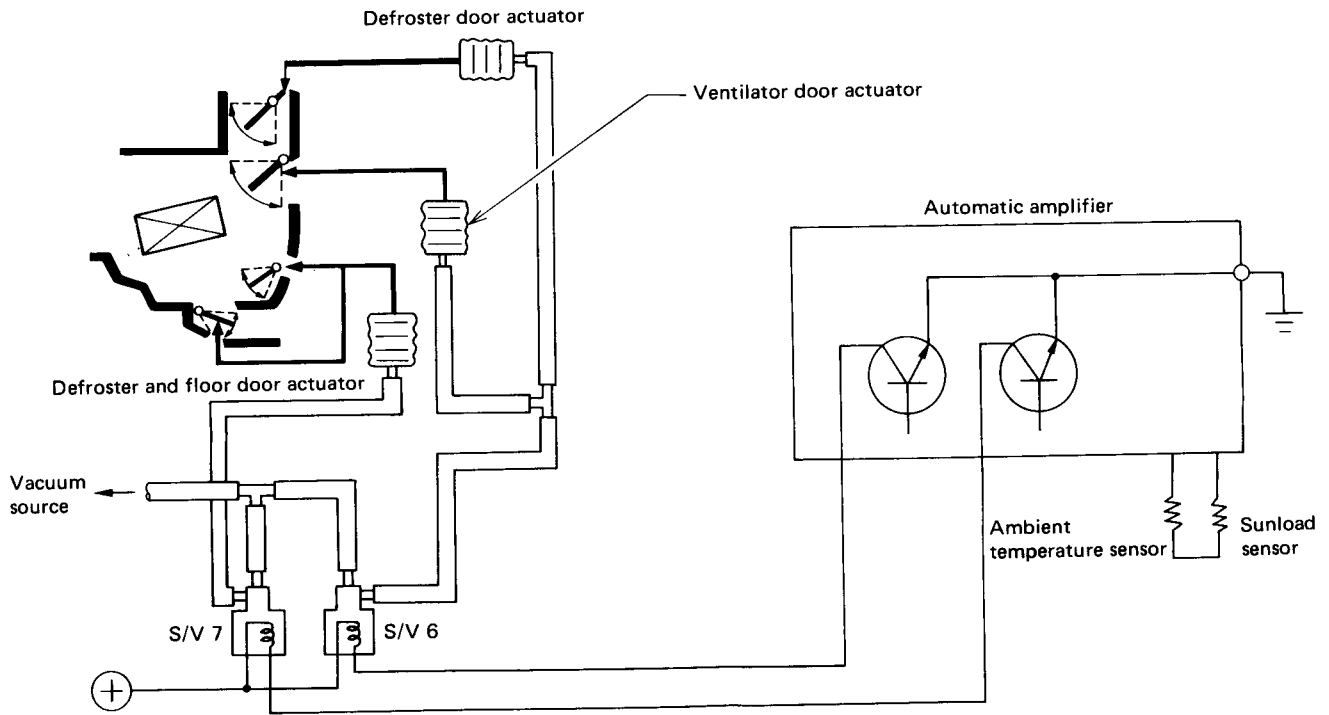

SHA291B

The outlet door is switched to HEAT, B/L, or VENT at the positions already memorized in the auto amplifier, corresponding to the ambient air temperature and sunload.

Condition: Very fine in midsummer
 (Sunload: Approximately 0.768 kW
 (660 kcal/h, 2,619 BTU/h)/m²
 [0.0713 kW (61.3 kcal/h, 243.2 BTU/h)/sq ft])

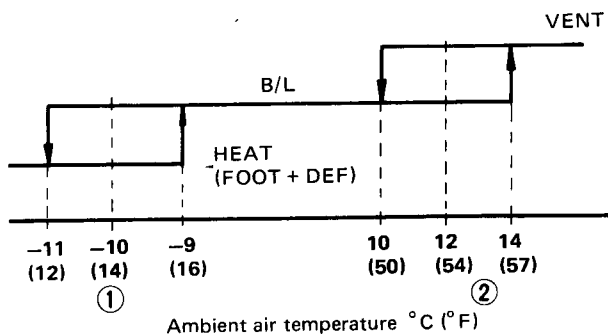

SHA307B

The relationship between the ambient air temperature and outlet door is as shown below.
 If the sunload increases, points ① and ② are moved in parallel direction to the arrow by the distance corresponding to the increase in sunload.

Condition: No sunload

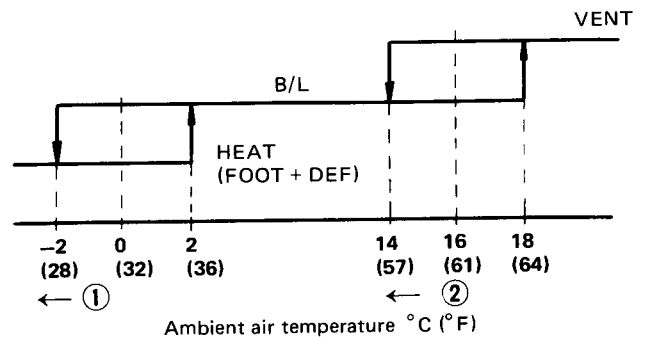

SHA308B

DESCRIPTION — Air Conditioner (Auto)

System Operation (Air flow volume control)

AIR FLOW VOLUME CONTROL

1. Component parts

Power transistor is added to the component parts of air mix door control system.

- **Power transistor**

Power transistor varies blower speed automatically according to the signal from automatic amplifier.

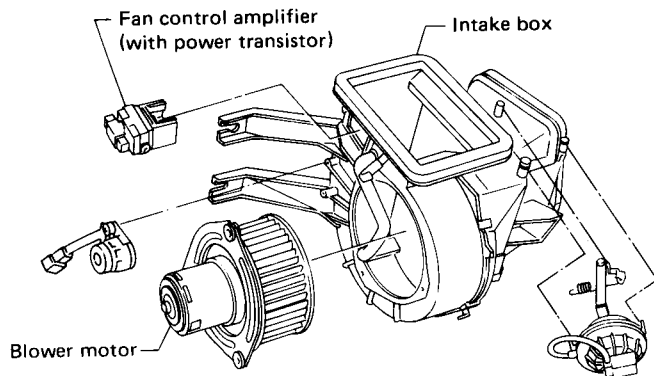

SHA318B

2. System operation of air flow volume control

The auto amplifier computes signals from the setting temperature switch and sensors that compose the air mix door control, and sends the control signal voltage (V_{IN} : 0.6 to 4 V) to the power transistor.

The power transistor amplifies this control signal voltage to change the voltage (V_M) fed to the motor terminals. Accordingly, the air flow is controlled automatically. With the manual fan switch, the voltage is fixed at 5.5V for LO, and at 12V for HI position.

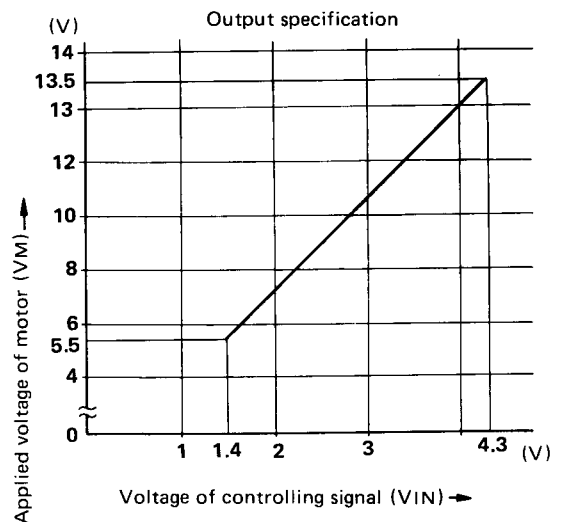
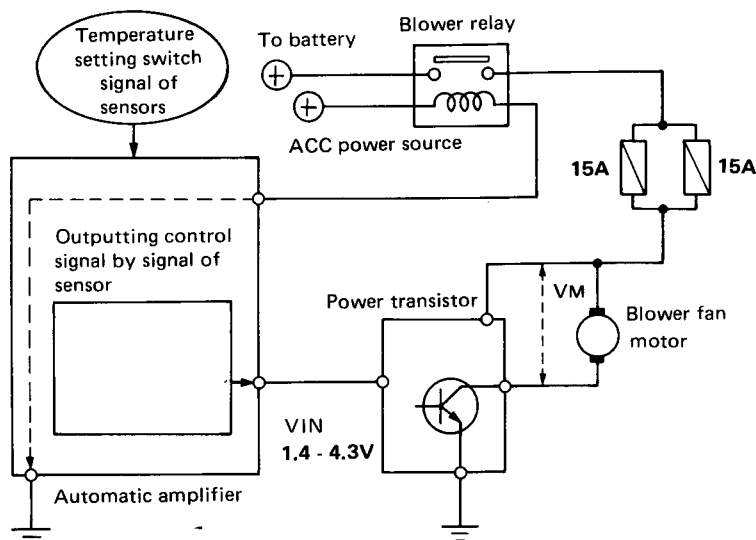

SHA309B

DESCRIPTION — Air Conditioner (Auto)

System Operation (Air flow volume control) (Cont'd)

3. Specification of air flow volume control (Automatic control)

- When "AUTO" switch is ON:

VENT mode

The air flow volume control voltage is determined according to the difference between the objective temperature at head level and the actual room temperature at head level. This voltage varies within the range of 5.5V to 12V.

The V_M max is determined according to the difference between the ambient temperature and objective temperature, and this voltage varies within the range of from 9V to 12V.

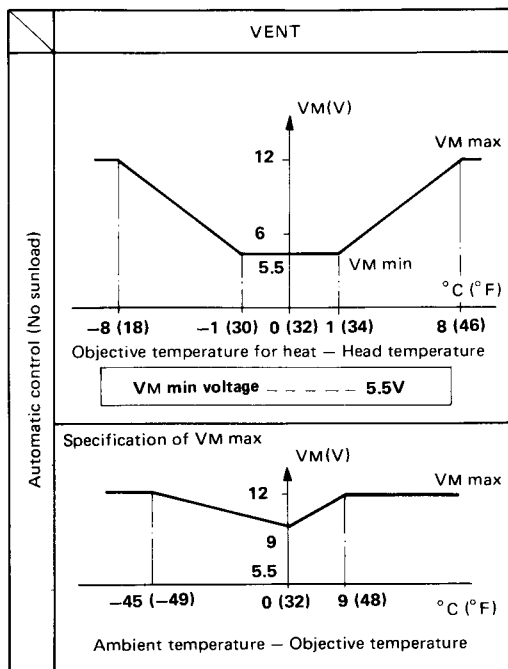

SHA310B

B/L, HEAT mode

The air flow volume control voltage is determined according to the difference between the average room temperature and the objective temperature. This voltage varies within the range of 6V to 12V. The V_M max varies within the range of 9V to 12V, just like in the case of VENT.

When the DEMIST switch on the DEF switch is ON, the V_M min voltage is fixed at 8V. Accordingly, the control voltage varies within the range of 8V to 12V.

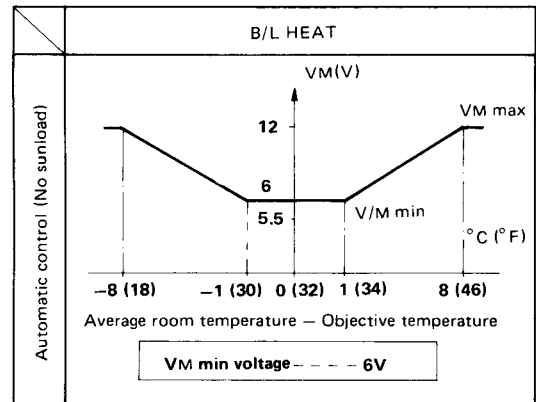

SHA311B

4. Compensation of air flow volume when sunload exists

In order to compensate for a change in room temperature depending on whether or not the sunload exists, the air flow volume is corrected according to the following diagram.

In VENT V_M min: 5.5 to 7 V
 Except VENT V_M min: 6 to 7 V
 (In both cases, the upper limit of compensation is 7V.)

V_M max is the same as when no sunload exists.

If the DEMIST switch is ON, compensation of air flow volume by sunload does not occur.

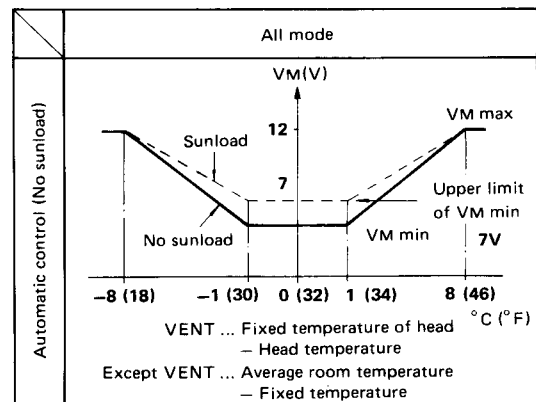

SHA292B

DESCRIPTION — Air Conditioner (Auto)

System Operation (Control at starting)

CONTROL AT STARTING

1. Component parts

Water temperature switch is added to the component parts of air mix door control system.

- **Water temperature switch**

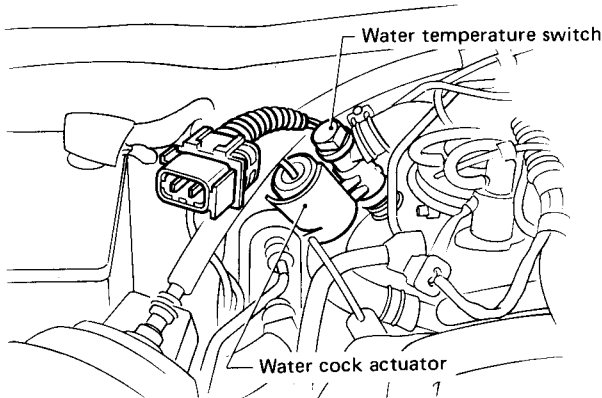

SHA312B

Specification

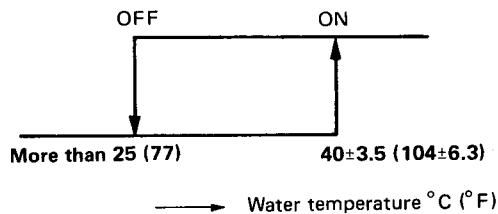

SHA293B

2. System operation of control at starting

- Curve ① means that the coolant temperature is below 40°C (104°F) and the room temperature at head level is lower than the objective temperature by more than 5°C (9°F). (Example: When sunload does not exist in winter)
- Curve ② means that the coolant temperature is below 40°C (104°F) and the room temperature at foot level is only lower than the objective temperature. (Example: When sunload exists in winter)
- Curve ③ means that the room temperature at head level is higher than the objective temperature by more than 5°C (9°F) and the room temperature at foot level is also higher than the objective temperature. (The outlet door is controlled by the outlet door control signal.)
- Curve ④ means that the difference between the objective temperature and actual room temperature is less than 8°C (14°F).

In cases ① and ② when the voltage is higher than 6V, the outlet door is determined by the outlet door control signal.

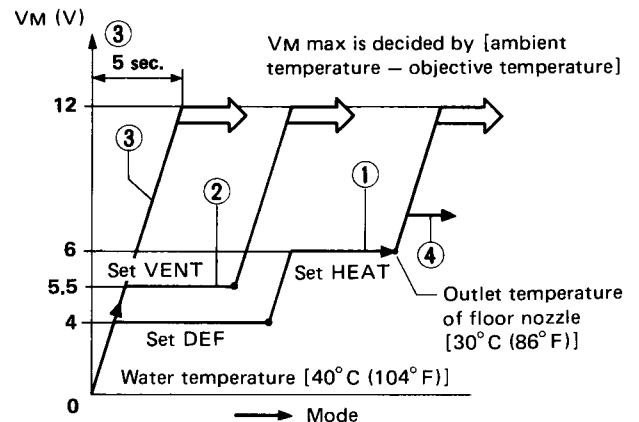

SHA313B

DESCRIPTION — Air Conditioner (Auto)

System Operation (Compressor, water cock control and compensation for ambient temperature)

COMPRESSOR CONTROL

- "ECON" mode: OFF
- Except for "ECON" mode:

Ambient temperature	Control
More than 0°C (32°F)	ON
Less than 0°C (32°F)	OFF

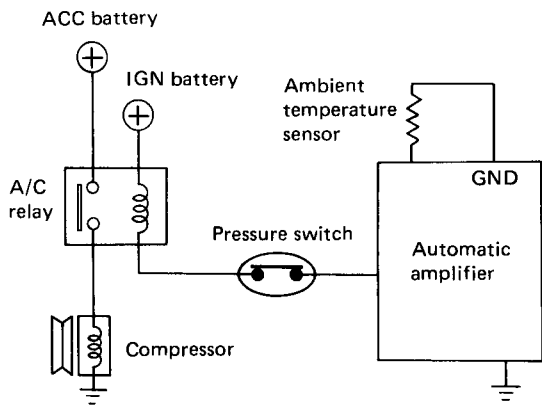

SHA294B

WATER COCK CONTROL

When the ambient temperature is lower than the objective temperature, the water cock is kept open. In other cases, the water cock is opened or closed at the position already memorized in the auto amplifier corresponding to the opening angle of the air mix door 1.

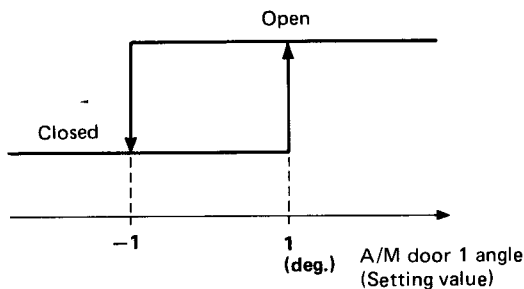

SHA314B

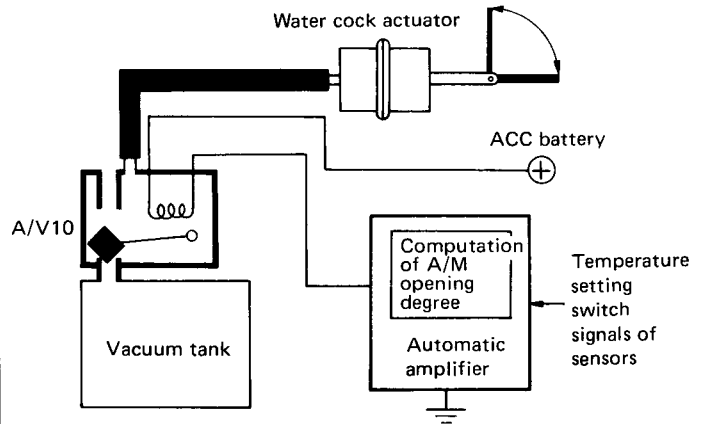

SHA295B

COMPENSATION FOR AMBIENT TEMPERATURE

In the temperature control system, the head-level and foot-level objective temperatures are compensated for a change in the ambient temperature.

For example, when the setting temperature is 25°C (77°F), and if the ambient temperature is 0°C (32°F), the foot-level objective temperature is compensated to 30.5°C (87°F) and the head-level objective temperature to 26.5°C (80°F). If the ambient temperature is higher than 20°C (68°F), the objective temperature at both levels is 26.5°C (80°F).

Specification of objective temperature
[When the setting temperature is 25°C (77°F)]

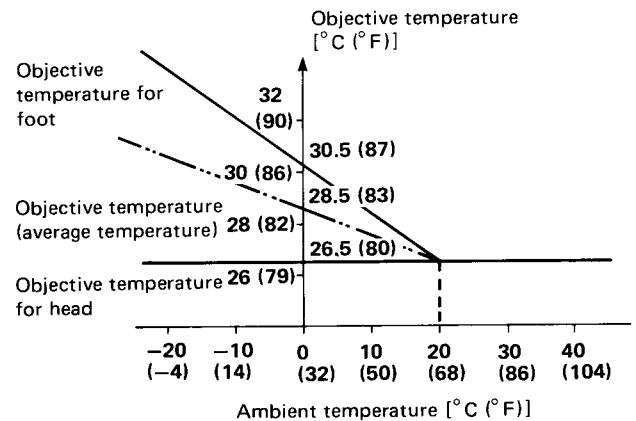

SHA315B

DESCRIPTION — Air Conditioner (Auto)

System Operation (Function of set TEMP. adjuster)

FUNCTION OF SET TEMP. ADJUSTER

TEMP. SET ADJUSTER changes the value of the objective controlling temperature shown above, according to the ambient temperature, to the next value shown below.

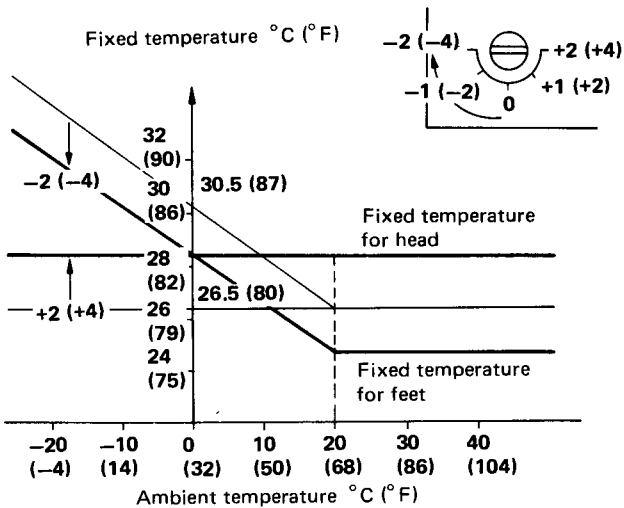
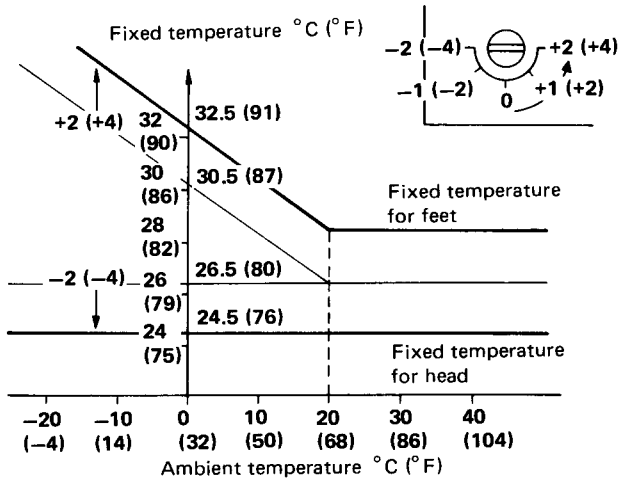

DESCRIPTION — Air Conditioner (Auto)

Function of Self-Diagnosis of Trouble

The self-diagnosis program is used to locate trouble and is composed of the following two steps:

- Step 1 Inspection of input system
- Step 2 Inspection of output system

- Diagnosing check connector

To change the system to the diagnosis mode, short the check terminal located at the lower portion of the cooling unit.

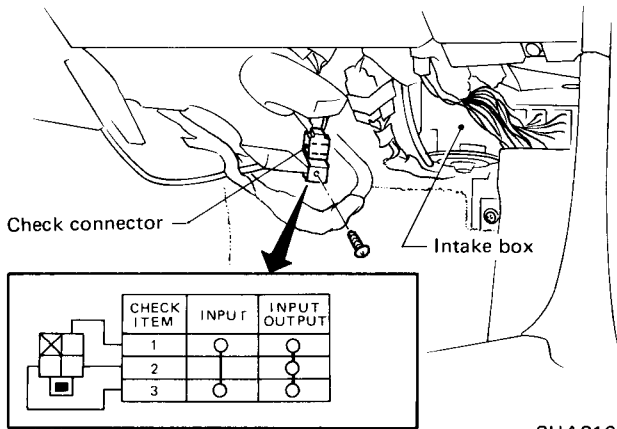

SHA316B

STEP 1 INSPECTION OF INPUT SYSTEM

The number of the part being checked and the value detected by that part (whether that part is disconnected or shorted) is displayed on the temperature display section by the setting temperature switch.

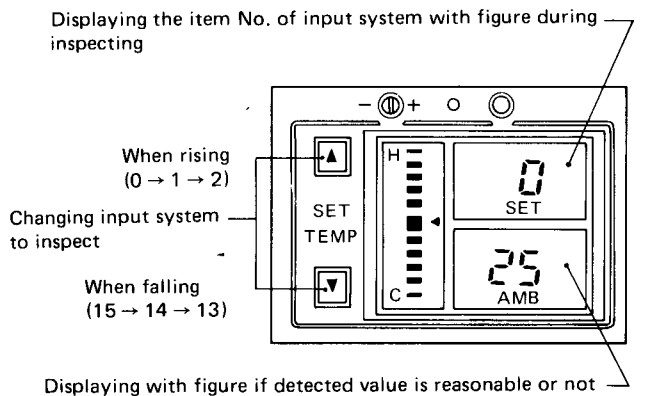

SHA317B

Display No.	Item of input signal	Parts to be checked
0	Temperature of inside air temperature sensor (foot)	In-vehicle sensor (foot)
1	Temperature of in-vehicle sensor (head)	In-vehicle sensor (head)
2	Temperature of floor outlet	Floor duct temperature sensor
3	Temperature of ventilator outlet	Ventilator duct temperature sensor
4	Temperature of defroster outlet	Defroster duct temperature sensor
5	Water temperature SW. display ON-OFF	Water temperature SW.
6	Sunload	Sunload sensor
7	Width of objective temperature	Set temp. adjuster
8	Position of A/M door 2	P.B.R. 2
9	Position of A/M door 1	P.B.R. 1
10~ 15	No meaning	No meaning

STEP 2 INSPECTION OF OUTPUT SYSTEM

- Whether the parts of the output system are operating normally according to the predetermined pattern can be checked by applying a hand to the outlet door, observing the air flow indicator, listening to the operating noise, or by measuring the applied voltage.
- Once the step 2 program starts, the following six parts begin their operation sequentially, moving between stroke ends or changing all positions.

- **Operating parts**

- **Operating parts**

1. Air mix door 1 and air mix door 2 (same motion)
2. Outlet doors (All mode)
3. Intake door
4. Water cock
5. Compressor magnet clutch
6. Blower motor

AIR FLOW AND COMPONENT LAYOUT (Auto)

Air Flow

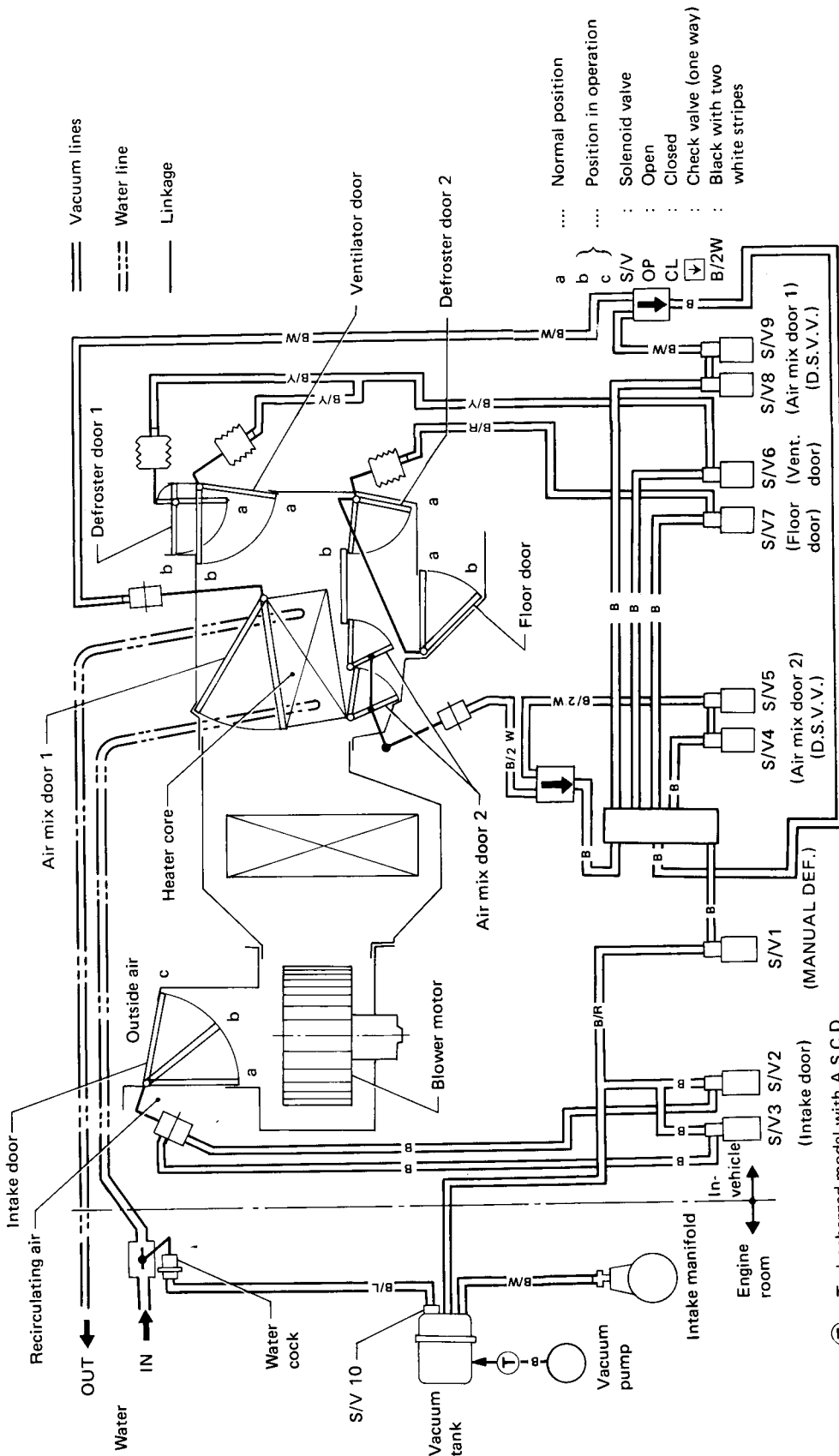

Ⓓ : Turbocharged model with A.S.C.D.

INTAKE CONTROL		INTAKE AIR		PARTIAL OUTSIDE		OUTSIDE	
INTAKE DOOR POSITION	S/V2	OP	CL	OP	CL	OP	CL
OPERATION OF SOLENOID VALVE	S/V3	OP	CL	OP	CL	OP	CL

AIR MIX DOOR CONTROL		HOT side		COLD side	
Air mix door 1	S/V8	CL	OP	CL	OP
Air mix door 2	S/V9	CL	OP	CL	OP
OPERATION OF SOLENOID VALVE	S/V4	CL	OP	CL	OP
	S/V5	CL	OP	CL	OP

S/V1 CONTROL		MANUAL DEF. SWITCH		OFF	
OPERATION OF SOLENOID VALVE	S/V1	CL	OP	CL	OP

OUTLET CONTROL		VENT		HEAT/DEMIST		DEF	
DEF. DOOR 1	b	b	a	a	a	a	a
VENT. DOOR	a	b	a	a	a	a	a
FLOOR DOOR	a	b	b	b	a	a	a
DEF. DOOR 2	a	b	b	b	a	a	a
S/V6	OP	OP	CL	CL	CL	CL	CL
S/V7	CL	OP	OP	OP	CL	CL	CL

WATER COCK CONTROL		OPEN		CLOSED	
OPERATION OF SOLENOID VALVE	S/V10	CL	OP	CL	OP

SHA612B

AIR FLOW AND COMPONENT LAYOUT (Auto)

Component Layout

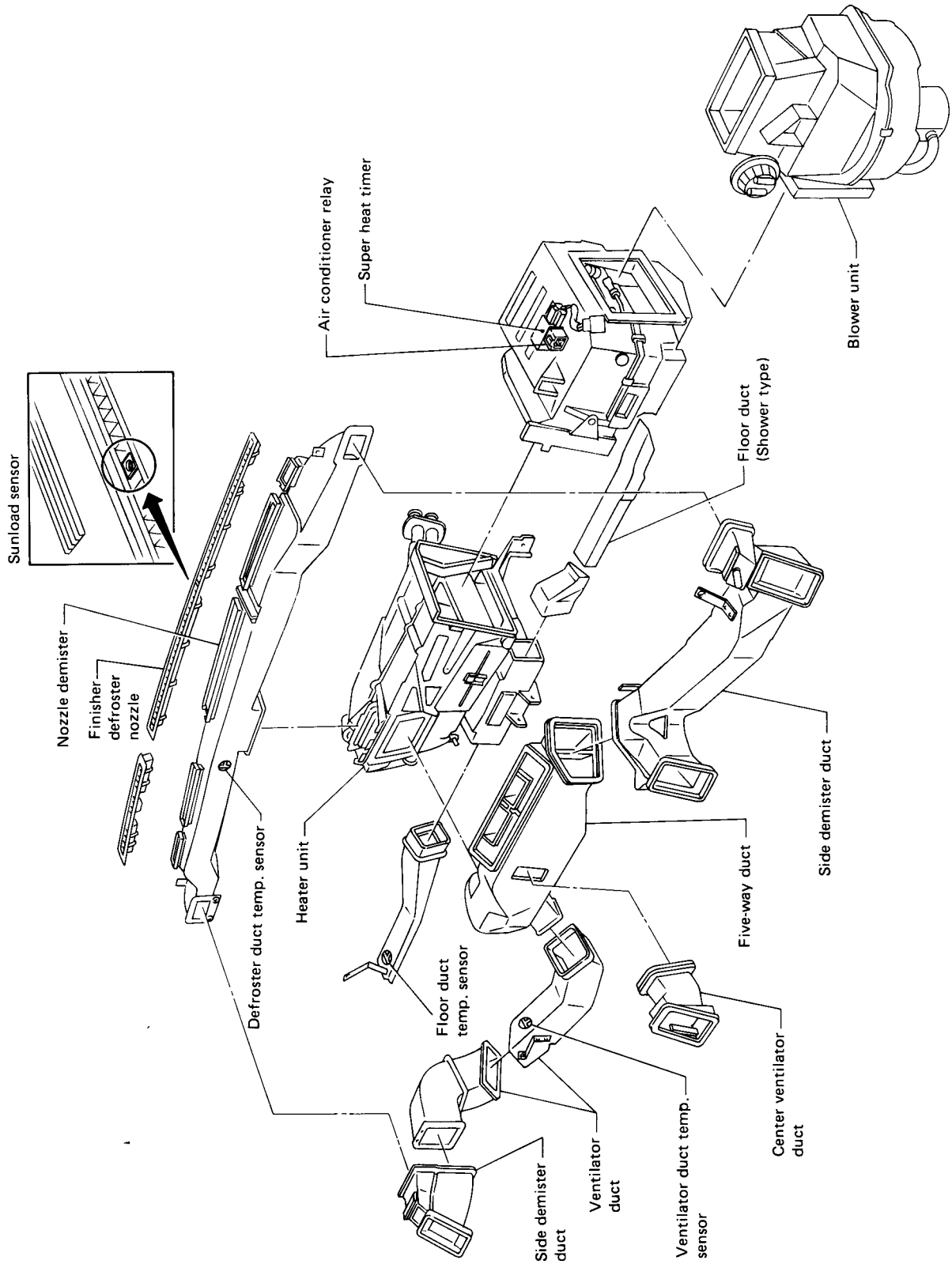

SHA278B

LOCATION OF VACUUM COMPONENTS (Auto)

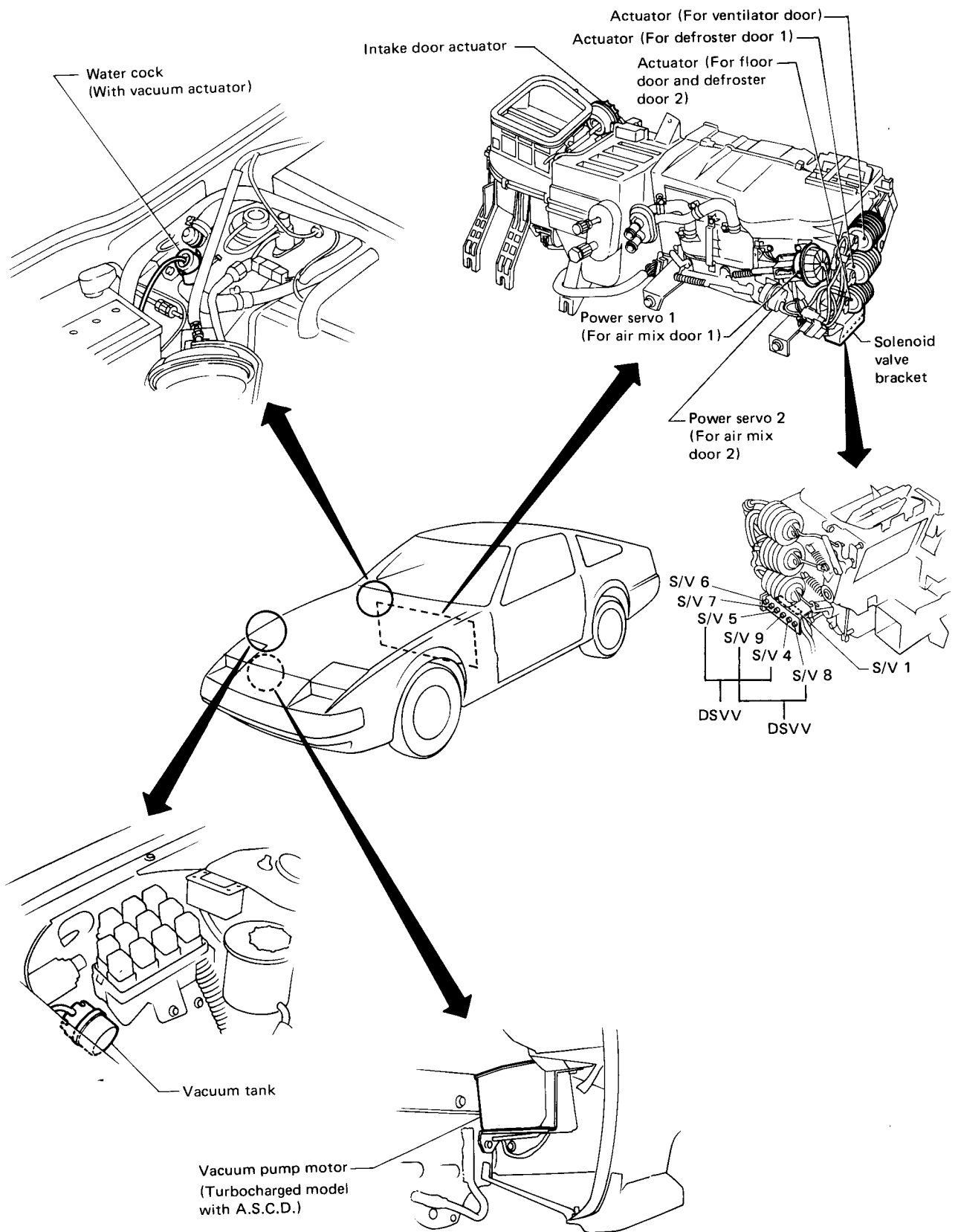

SHA341B

A/C PERFORMANCE TEST (Auto)

Performance Chart

TEST CONDITION

Testing must be performed as follows:

Vehicle location:	Indoors or in the shade (in a well ventilated place)
Ambient temperature	More than 14°C (57°F)
Doors:	Closed
Door window:	Open
Hood:	Open
SET TEMP. switch position:	Max. COLD
Auto switch position:	A/C (Ventilation mode)
Recirculation switch position:	RECIRC. ON
FAN switch position	HI. ON
Engine speed:	1,500 rpm
Time required before starting testing after air conditioner starts operating:	More than 10 minutes

*Connect 895 (L/B) and 866 (BR/W) terminals of check connector with jumper wire.

TEST READING

Recirculating-to-discharge air temperature table

Inside air (Recirculating air) at blower assembly inlet		Discharge air temperature at center ventilator °C (°F)
Relative humidity %	At temperature °C (°F)	
50 - 70	20 (68)	3.0 - 5.0 (37 - 41)
	25 (77)	5.5 - 8.5 (42 - 47)
	30 (86)	10.0 - 13.5 (50 - 56)
	35 (95)	14.7 - 18.4 (58 - 65)
	40 (104)	19.5 - 23.2 (67 - 74)
70 - 90	20 (68)	5.0 - 7.0 (41 - 45)
	25 (77)	8.5 - 11.5 (47 - 53)
	30 (86)	13.5 - 17.0 (56 - 63)
	35 (95)	18.4 - 21.8 (65 - 71)
	40 (104)	23.2 - 26.8 (74 - 80)

A/C PERFORMANCE TEST (Auto)/PIPING (Auto)

Performance Chart

Ambient air temperature to compressor pressure table

Ambient air		Low pressure (Suction side) kPa (kg/cm ² , psi)	High pressure (Discharge side) kPa (kg/cm ² , psi)
Relative humidity %	Air temperature °C (°F)		
50 - 70	20 (68)	59 - 98 (0.6 - 1.0, 9 - 14)	755 - 892 (7.7 - 9.1, 109 - 129)
	25 (77)	78 - 127 (0.8 - 1.3, 11 - 18)	883 - 1,030 (9.0 - 10.5, 128 - 149)
	30 (86)	98 - 157 (1.0 - 1.6, 14 - 23)	1,010 - 1,187 (10.3 - 12.1, 146 - 172)
	35 (95)	118 - 186 (1.2 - 1.9, 17 - 27)	1,138 - 1,334 (11.6 - 13.6, 165 - 193)
	40 (104)	137 - 216 (1.4 - 2.2, 20 - 31)	1,295 - 1,510 (13.2 - 15.4, 188 - 219)
70 - 90	20 (68)	98 - 137 (1.0 - 1.4, 14 - 20)	883 - 1,020 (9.0 - 10.4, 128 - 148)
	25 (77)	127 - 177 (1.3 - 1.8, 18 - 26)	1,030 - 1,177 (10.5 - 12.0, 149 - 171)
	30 (86)	157 - 216 (1.6 - 2.2, 23 - 31)	1,187 - 1,344 (12.1 - 13.7, 172 - 195)
	35 (95)	186 - 255 (1.9 - 2.6, 27 - 37)	1,334 - 1,530 (13.6 - 15.6, 193 - 222)
	40 (104)	216 - 304 (2.2 - 3.1, 31 - 44)	1,510 - 1,736 (15.4 - 17.7, 219 - 252)

- a. The pressure will change in the following manner with changes in conditions:
- When blower speed is low, discharge pressure will drop.
 - When the relative humidity of intake air is low, discharge pressure will drop.

- b. The temperature will change in the following manner with changes in conditions:
When the ambient air temperature is low, the outlet air temperature will become low.

Refrigerant Lines—Cooling Unit

- Refrigerant lines for auto A/C are the same as for manual A/C.

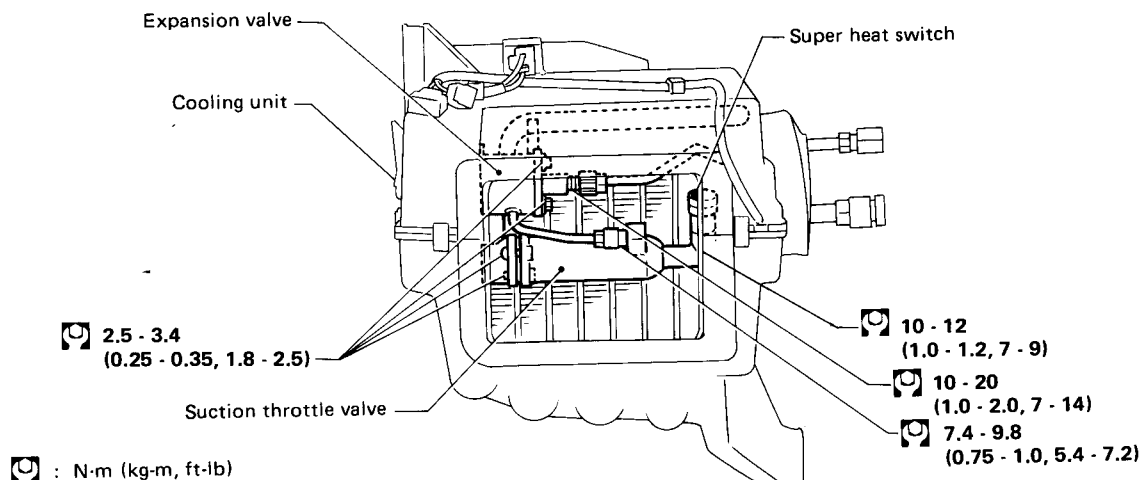

SHA281B

A/C ELECTRICAL CIRCUIT (Auto)

Schematic

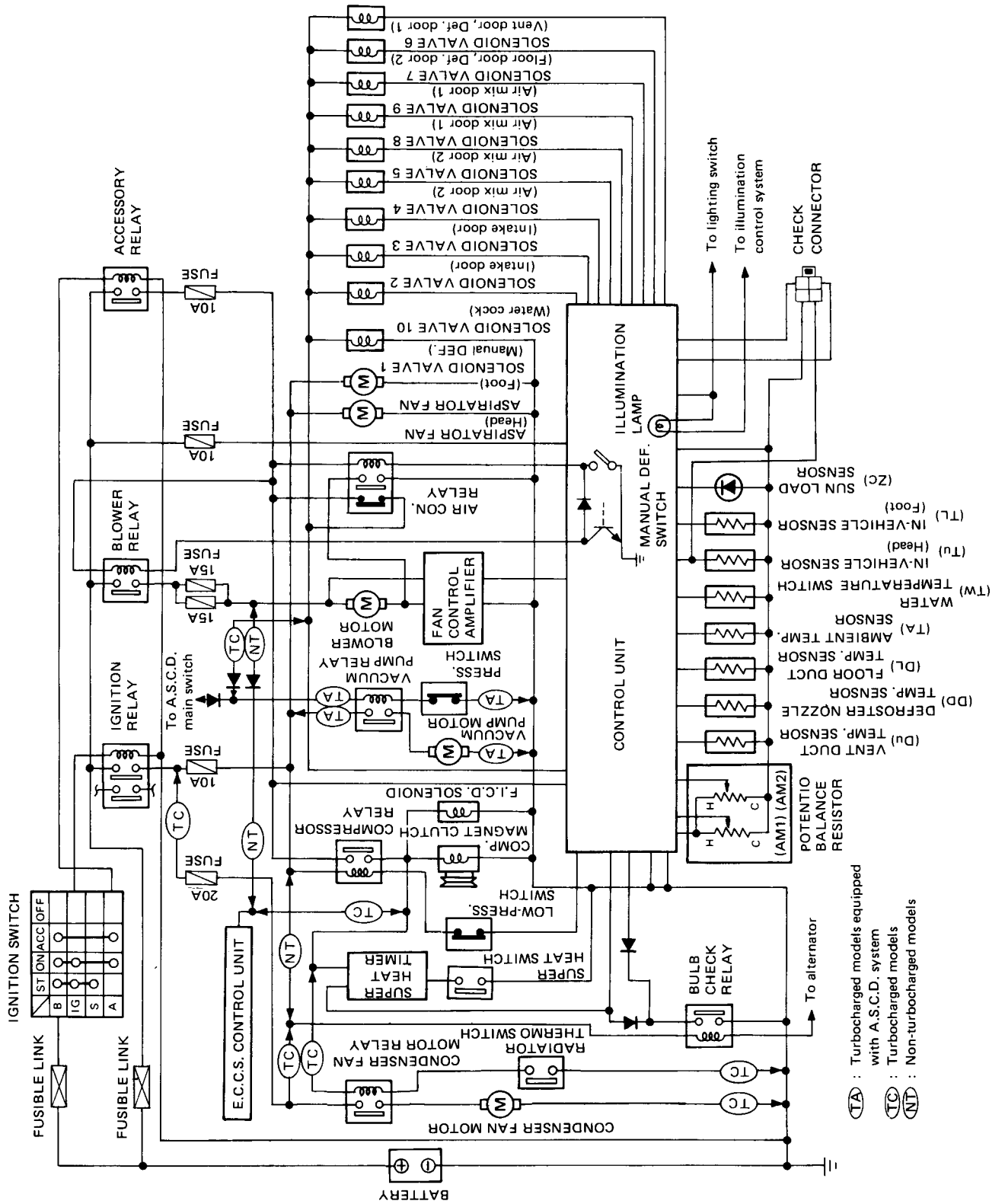

SHA518B

A/C ELECTRICAL CIRCUIT (Auto)

Notes:

A/C ELECTRICAL CIRCUIT (Auto)

Wiring Diagram

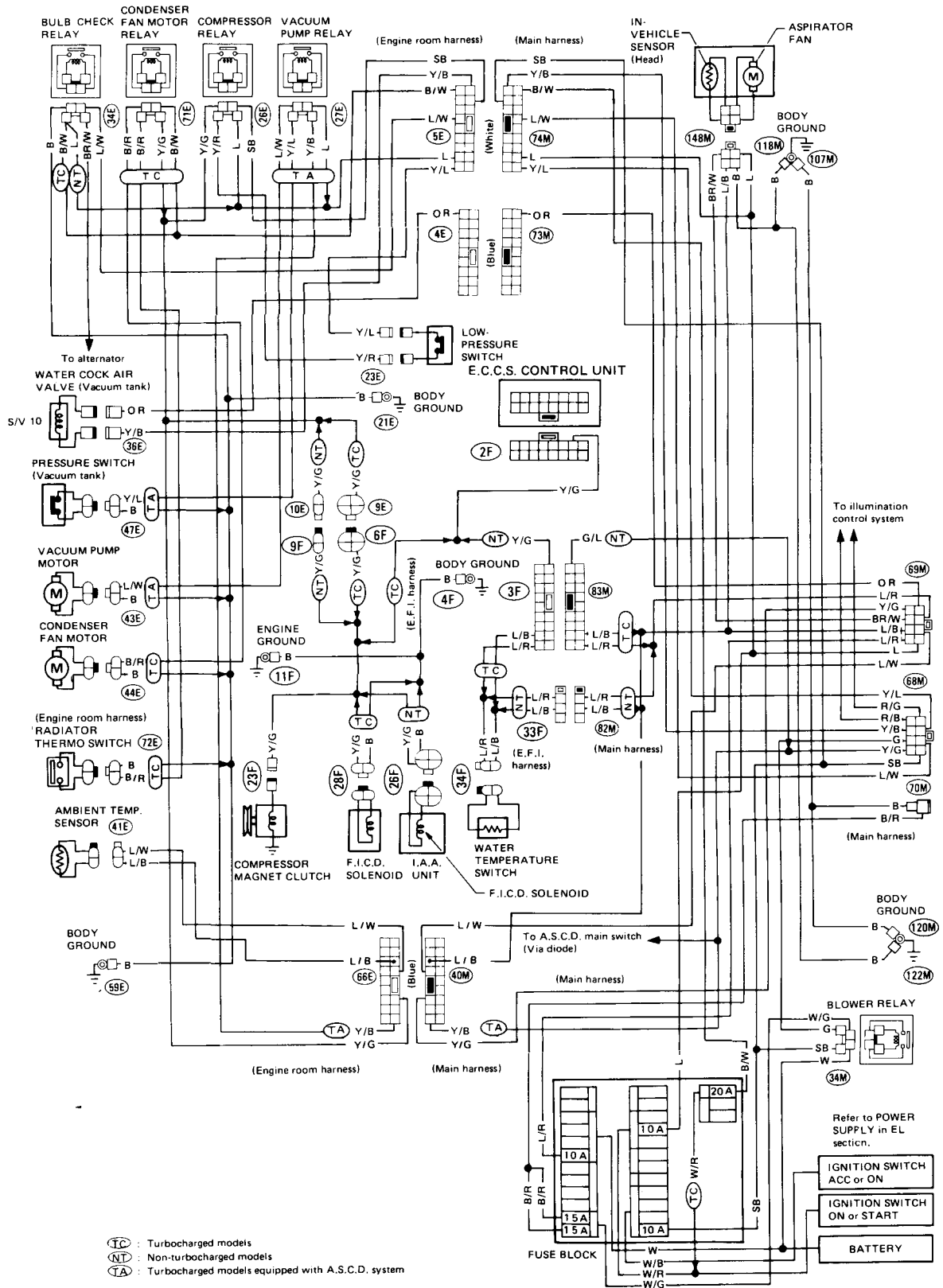

A/C ELECTRICAL CIRCUIT (Auto)

Wiring Diagram (Cont'd)

*Connector pin numbers are valid only for this page.

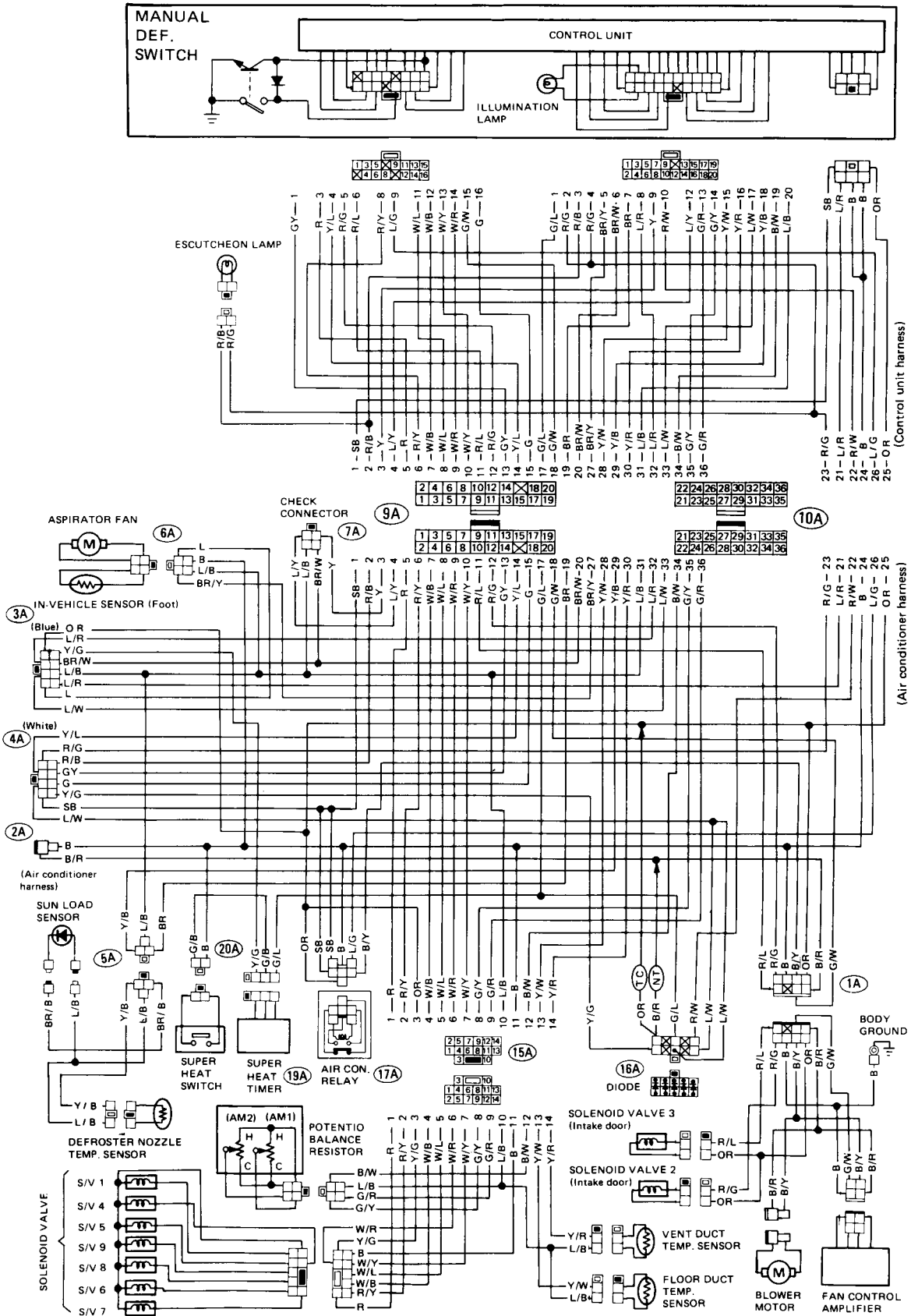

SHA605B

A/C ELECTRICAL COMPONENTS (Auto)

Inspection

IN-VEHICLE SENSOR AT HEAD OR FOOT (with aspirator fan)

- For aspirator fan, check the air flow when applying voltage.
- For thermistor detecting temperature, refer to "SELF – DIAGNOSING SYSTEM OF TROUBLE" and "DESCRIPTION – AUTO A/C". [System Operation (Air mix door control)].

WATER TEMPERATURE SWITCH

1. Disconnect vacuum hose and two heater hoses and harness connector.
2. Dip the water cock assembly in a container filled with cold water and increase the temperature of the water. The switch should turn "ON".

Refer to DESCRIPTION – AUTO "A/C"
[System operation (Control at starting)].

NOTICE

- Do not separate the switch from the water cock assembly.

SUNLOAD SENSOR

- Check the operation of the pointer of the micro-ammeter when pointing the flashlight toward the sensor and turning it off and on.
Refer to DESCRIPTION – AUTO "A/C"
[System operation (Air mix door control)].

LOCATION OF A/C ELECTRICAL COMPONENTS (Auto)

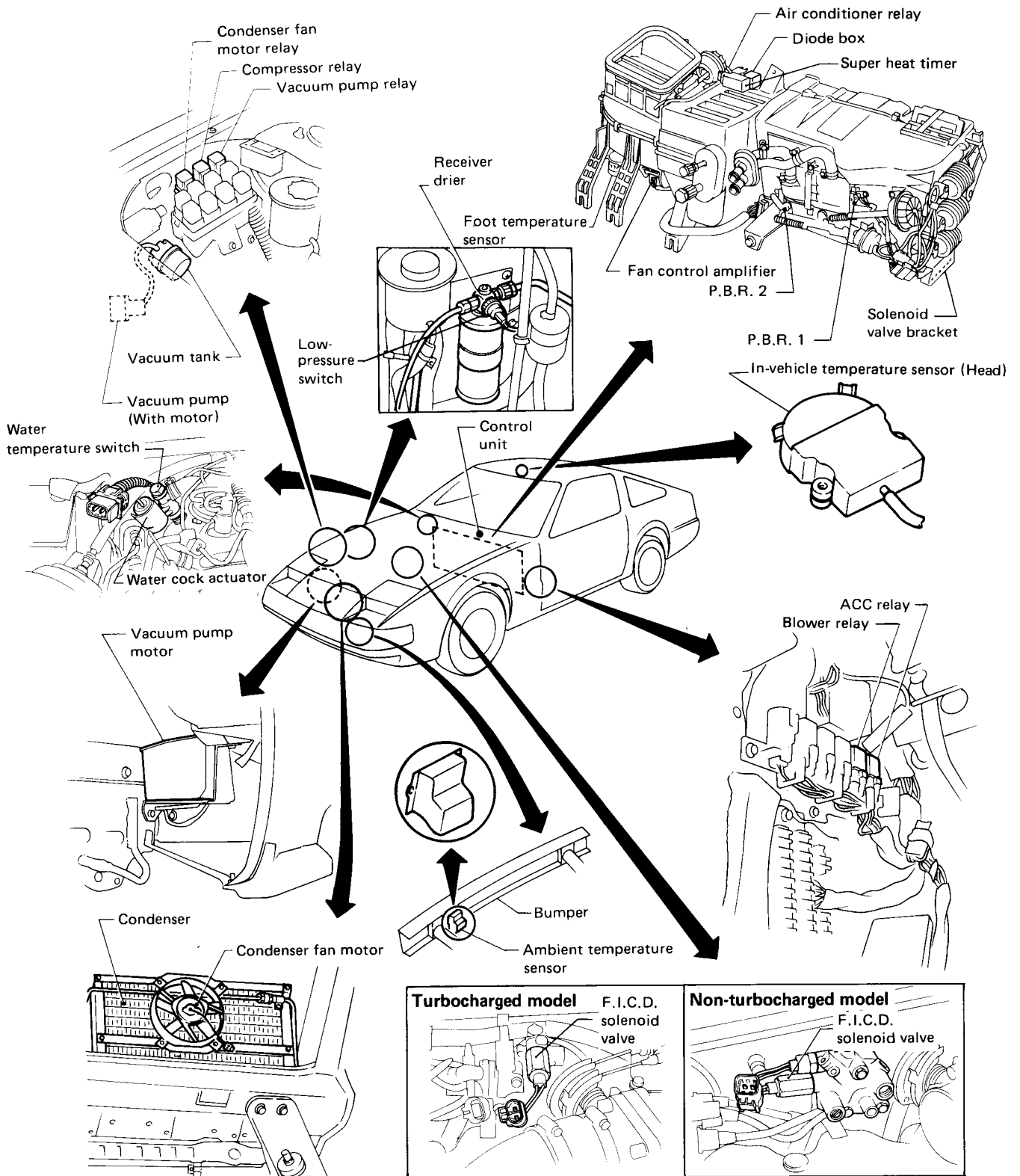

SHA342B

LOCATION OF A/C ELECTRICAL COMPONENTS (Auto)

Diagnostic Procedure

Listen carefully to the customer's complaint to correctly understand the problem. Then start the engine, sit in the seat, and operate the control panel to check system operation on the following items (A) to (D). In this case, check whether the air outlet grille is oriented correctly; if necessary, correct its orientation before starting inspection.

A.T.C. normal operating condition	Trouble diagnosis
<p>(A) Ignition key ON</p> <p>(a) SET and AMB temperatures are indicated on digital meters. (Air flow indicator is not lighted.)</p> <p>(b) With blower OFF, automatic temperature control operates in ram pressure temperature control mode. (This system is adopted on the '85 models. For '84 models, the air outlet is fixed at DEF.)</p>	<p>(1) Check if MANUAL DEF SW is depressed. (when all indicator lamps are off and blower is set at Hi.)</p> <p>(2) Check if the power supply is connected to the control amplifier.</p> <p>(3) Check if the body ground terminal of the control amplifier is connected to ground.</p> <p>If items (1), (2) and (3) above are all normal but item (a) at left is not normal, the control unit is faulty.</p> <p>When the ram pressure temperature control or mode control or mode control is faulty with A/C switch OFF, use the self-diagnosis program.</p>
<p>(B) Model SW (AUTO, DEF) ON</p> <p>(a) The outlet mode is determined according to the ambient air temperature and sunload.</p> <p>* If the engine cooling water temperature is low when starting the engine, the system is set temporarily in the start control model.</p> <p>Example</p> <ul style="list-style-type: none"> ○ Low Tu and Low Tw → Start in DEF mode ○ High Tu, Low TL and Low Tw → Start in VENT mode <p>(b) If ambient air temperature is above 0°C (32°F) in A/C mode, COMP is ON.</p> <p>(1) In economy mode, comp is OFF.</p> <p>(2) DEF SW ON</p> <p>(a) In-DEMIST mode, air comes out of FLOOR and DEF. Lo: 8V Automatic temperature control and REC switch are refused.</p> <p>(b) In DEF mode, air comes out only from DEF. Manual Lo is operable.</p>	<p>(1) Items to be checked when mode control is abnormal.</p> <ul style="list-style-type: none"> (a) Ambient temperature sensor (b) Sunload sensor ... Perform self-diagnosis of input system. (c) Air valve, actuator ... Perform self-diagnosis of input & output system. (d) Check harness connectors. <p>(2) Checking procedure when start control is faulty</p> <ul style="list-style-type: none"> (a) Water temperature sensor (b) TdL sensor (c) Tu, TL sensors <p>Perform self-diagnosis of input system.</p> <ul style="list-style-type: none"> (d) Air valve actuator ... Perform self-diagnosis of input & output system. (e) Check wiring and harness connectors <ul style="list-style-type: none"> (a) Ambient temperature sensor ... Perform self-diagnosis of AMB temperature indication and input & output system. (b) Harness wiring and connectors (a) Air valve and actuator (b) COMP Magnet clutch <p>Perform self-diagnosis of input & output system.</p> <ul style="list-style-type: none"> (a) Air valve actuator (for blower door) (b) Blower speed <p>Perform self-diagnosis of input & output system.</p> <ul style="list-style-type: none"> (a) Perform self-diagnosis of input & output system.

LOCATION OF A/C ELECTRICAL COMPONENTS (Auto)

Diagnostic Procedure (Cont'd)

A.T.C. normal operating condition	Trouble diagnosis
<p>(C) TEMP SW change</p> <p>(1) Air outlet temperature varies with a change in set temperature.</p> <p>(2) Blower speed varies with the set temperature.</p> <p>(3) W/C operation and intake mode vary with the set temperature.</p>	<p>(a) T_L, T_u, T_{dL}, T_{du}, T_{dd}, T_w, Z_c, T_a ... Self-diagnosis of input system</p> <p>(b) P_L, P_u ... Self-diagnosis of input & output system</p> <p>(c) Air valve, actuator ... Self-diagnosis of input & output system</p> <p>(d) Check wiring and connectors.</p> <p>(a) T_L, T_u</p> <p>(b) Fan control system Perform self-diagnosis of input & output system.</p> <p>(a) Air valve and actuator (For control of intake door) (For control of water cock) Perform self-diagnosis of output system.</p>
<p>(D) manual SW operation</p> <p>(1) Blower speed is set at Hi or Lo by blower Hi-Lo switch.</p> <p>(2) Air intake mode is changed to REC mode by REC SW.</p>	<p>(1) Fan control system Perform self-diagnosis of input & output system.</p> <p>(2) Air valve and actuator (For control of intake door) Perform self-diagnosis of input & output system.</p>

(1) Diagnosing functions

The diagnostic program facilitates detection of failed points, and permits diagnosis in the following two modes:

- (a) Input system inspection Inspection of sensor and potentiometer (Step 1)
- (b) Input-output system inspection Inspection of actuator, W/C, COMP, and blower motor simultaneously with inspection of item (a) (Step 2)

Shown below are examples of efficient use of this diagnostic function.

- * "Input system inspection" permits inspection of the temperature of all sensors, power servo stroke and other functions while operating the A.T.C. system normally. Hence, this can be utilized to determine whether or not a device is normal according to the data obtained.
- * In "Input & output system inspection", the specified control voltage is applied from the control unit to the blower control amplifier to control the blower motor speed when inspecting blower speed. Accordingly, whether the control unit and the blower control amplifier are normal or not can be determined by checking whether the control voltage is normal.
- * In the simultaneous inspection of the input & output system in item (b) above, the air-mix door is forcibly actuated by the specified stroke during inspection of the output system. By reading the potentiometer during inspection of the input system as mentioned in (a), it is possible to determine whether the temperature control system is operating normally.

SELF-DIAGNOSING SYSTEM OF TROUBLE (Auto)

Inspection of Input System

CHECKING PROCEDURES FOR INPUT SIGNALS

1. For Input Test I-0 through I-9, plug the test connector into the check connector. Do not connect the wire leads (A and B) at this time.

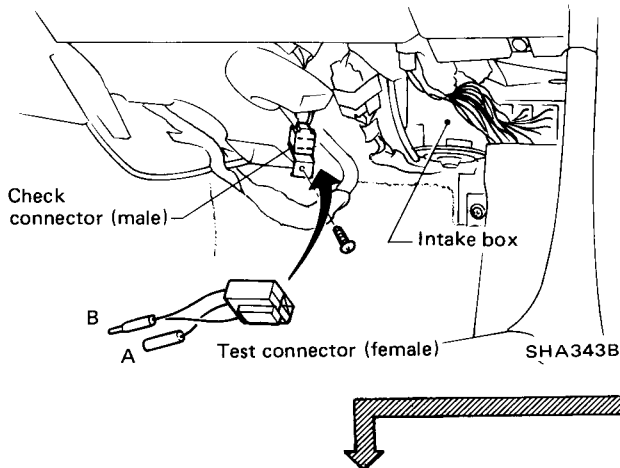

2. Turn the ignition to "ACC" position and press the "ECON/AC" button once.
3. Set data number by tuning set temp. button. Read figures indicated on "AMB" indicator.

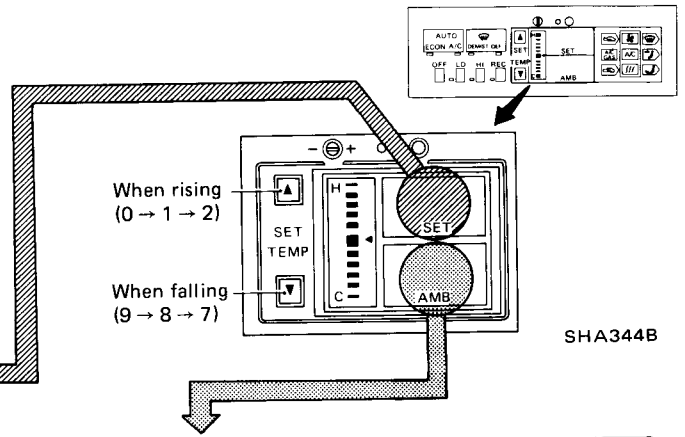

Abbrev.	Terminal No.	Indicated No.	Unit to be checked	Judgement (AMB section)	
				Good	No good
I-0	857 (BR/Y)	0	In-vehicle sensor (Foot level)	Indicates the temperature at inspection	-17 [2] ... Disconnection 83 [181] ... Short-circuit
I-1	863 (BR/W)	1	In-vehicle sensor (Head level)		
I-2	858 (Y/W)	2	Floor duct sensor		
I-3	860 (Y/R)	3	Vent duct sensor		
I-4	859 (Y/B)	4	Diff duct sensor		
I-5	862 (L/R)	5	Water temperature switch	Good	-17 [2] ... OFF ($T_w \leq 40^\circ\text{C}$, 104°F) 83 [181] ... ON ($T_w \geq 40^\circ\text{C}$, 104°F)
I-6	Zc (BR)	6	Sunload sensor		0 [32] (No sunlight) to approx. 40 [approx. 104] (Fine weather) ... Note 1)
I-7	-	7	Object temperature fine adjusting switch		0 - 64 [32 - 147]
I-8	870 (G/R)	8	FBP2 (Floor side)		Varies in the range of approx. 40 to approx. 20 [approx. 104 to approx. 68]
I-9	869 (G/Y)	9	FBP1 (Vent side)		
	-	10 - 15	-		-

Note 1) The value change gradually.

Note 2) The value in [] is for "F" marked items.
The letter in () indicates lead color.

SELF-DIAGNOSING SYSTEM OF TROUBLE (Auto)

Inspection of Ambient Temperature Sensor

1. Turn the ignition to "ACC" position.
2. Read figures indicated on "AMB" indicator.
3. How to judge

Terminal No. 864 (L/W)

The letter in () indicates lead color.

OK – Reasonable ambient temperature

–49 [–56] * : Open sensor

83 [181] : Shorted sensor

*Figures in [] indicate degrees Fahrenheit.
(U.S.A. model)

Inspection of Output System

CHECKING PROCEDURES FOR OPERATION OF ACTUATORS

1. For Input/Output System Test 0-1 to 0-6, connect leads A and B, and plug the test connector into check connector.

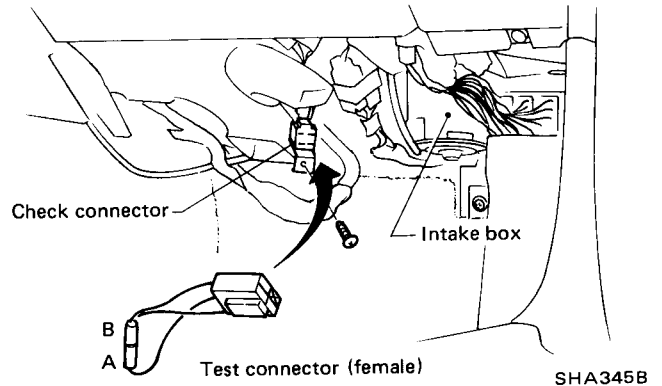

2. Start the engine and press the "ECON/AC" button.
3. Check that output parts operate smoothly using the following table.

- The way to make sure of the operation of actuators.

- 1) By digital indicator

SET No.
DATA No.

AMB
DATA

 .
- 2) By A/CON operation indicator.

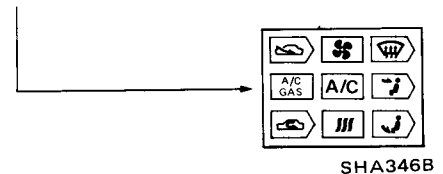

- How to read display in inspection chart.

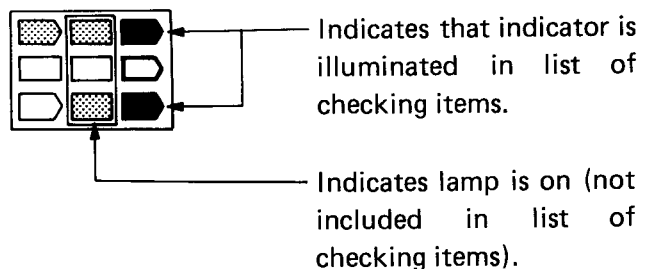

- 3) By feeling. (air velocity or temperature at ventilator grilles.)

SELF-DIAGNOSING SYSTEM OF TROUBLE (Auto)

Inspection of Output System (Cont'd)

Step No.	Checking item	Procedures of confirming operation	Time (SEC)					Terminal No.
			0	4	8	12	16	
O-1	Air mix door 1 (Upper)	<ul style="list-style-type: none"> Read the position of feedback potentiometer (1-9 steps) 						882 (W/R), 883 (W/Y)
	Objective display value							
O-1	Air mix door 2 (Lower)	<ul style="list-style-type: none"> Read the position of feedback potentiometer (1-8 steps) 						884 (W), 885 (W/L)
	Objective display value							
O-2	Outlet	<ul style="list-style-type: none"> Air conditioner operation indicator Touch with each outlet by hand. 						DEF/VENT Changeover 887 (R/Y) FOOT Opens/Closes 886 (R)
	Display							
O-3	Intake door	<ul style="list-style-type: none"> Air conditioner operation indicator Look at the intake door spring 						880(R/L), 881 (R/G)
	Display							
O-4	Water cock	<ul style="list-style-type: none"> Air conditioner operation indicator Look at the water cock and touch with the diaphragm of cock. 						564 (G1)
	Display							
O-5	Compressor clutch	<ul style="list-style-type: none"> Air conditioner operation indicator Look at the magnet clutch. 						567 (Y/L)
	Display ("REC" "DEF")							
O-6	Blower motor	<ul style="list-style-type: none"> Air conditioner operation indicator Touch with each outlet by hand. Measure the applied voltage of motor. 						Blower relay 571 Signal for amount of air 568 (G/W)
	Display							

*Figures in [] indicate degrees Fahrenheit (U.S.A. model).
The letter in () indicates lead color.

TROUBLE DIAGNOSES (Auto)

CONTENTS

Circuit for trouble diagnoses	HA-105
Connector inspection position and terminal arrangement for diagnosis	HA-106
Auto A/C system diagnosis	HA-108
(A0) Check to see if SET AMB. temperature is displayed when ignition switch is set to ACC, or when engine is running	HA-108
Input system diagnosis	HA-110
(B0) Inoperative input system	HA-110
Output system diagnosis	HA-112
1) Inoperative air mix door	HA-112
(C0) Input & output system: Check I-8 and I-9 for proper operation	HA-112
2) Doors, water cock and compressor diagnosis	HA-114
(D0) Check if 12 volts are present at terminal 867 (OR) with connector ⑨ in place	HA-114
(E0) Check if 12 volts are present at terminal 561 (OR) when connector ⑤ is connected	HA-115
(F0) Check if 12 volts are present at lead wire (OR) of air valve located on vacuum tank	HA-116
(G0) Check if 12 volts are present at lead wire (L side) of air conditioner relay located in engine compartment	HA-117
3) Blower motor diagnosis	HA-118
(H0) Conduct self-diagnostic checks on input & output system	HA-118
Automatic amplifier diagnosis	HA-120
1) LCD (Liquid Crystal Display) or LED (Light Emitting Diode) does not glow	HA-120
(I0) Do LCD's or LED's glow?	HA-120
2) Operating (Buzzing) sound is not emitted.	HA-121
(J0) Disconnect buzzer connector from control subassembly and apply 12 volts across buzzer terminals (red ⊕ and black ⊖) to see if buzzer sounds	HA-121
3) Switches on switch panel assembly do not operate.	HA-121
(K0) Does MANUAL DEF. switch turn on and off properly?	HA-121
4) Erroneous display during inspection of the input system	HA-122
(L0) Are all numbers except I-7* correct?	HA-122
5) Erroneous operation during inspection of the output system	HA-122
(M0) Does air flow indication change properly?	HA-122
6) Manual Def. indicator does not come on	HA-122
7) Escutcheon lamp does not come on	HA-122
Replacement of control subassembly and switch panel assembly	HA-123
Blower continues to rotate in HI mode	HA-124
Blower rotates only in LO mode	HA-124
Blower motor does not rotate	HA-125
Blower speed changes variably	HA-125
No air is discharged from vent outlets	HA-126
No air is discharged from floor outlets	HA-126
No air is discharged from defroster outlets	HA-127
Hot air is not discharged or outlet air temperature does not change	HA-127
No cool air is discharged	HA-128
Cool air at foot level will not stop or is discharged intermittently	HA-129
Outside air is not drawn into compartment	HA-129
Discharged air is too cool	HA-130
Discharged air is not cool	HA-130
Compartment is too hot	HA-131

TROUBLE DIAGNOSES (Auto)

Compartment will not become warm	HA-131
● Temperature of air discharged from floor outlets fluctuates	HA-132
● In-vehicle temperature fluctuates	HA-132
● Temperature of air discharged from def. outlets on instrument panel fluctuates	HA-132
Indicator lamp for refrigerant gas shortage is ON even though amount of refrigerant gas is appropriate A/C gas warning lamp comes on	HA-133

TROUBLE DIAGNOSES (Auto)

Circuit for Trouble Diagnoses

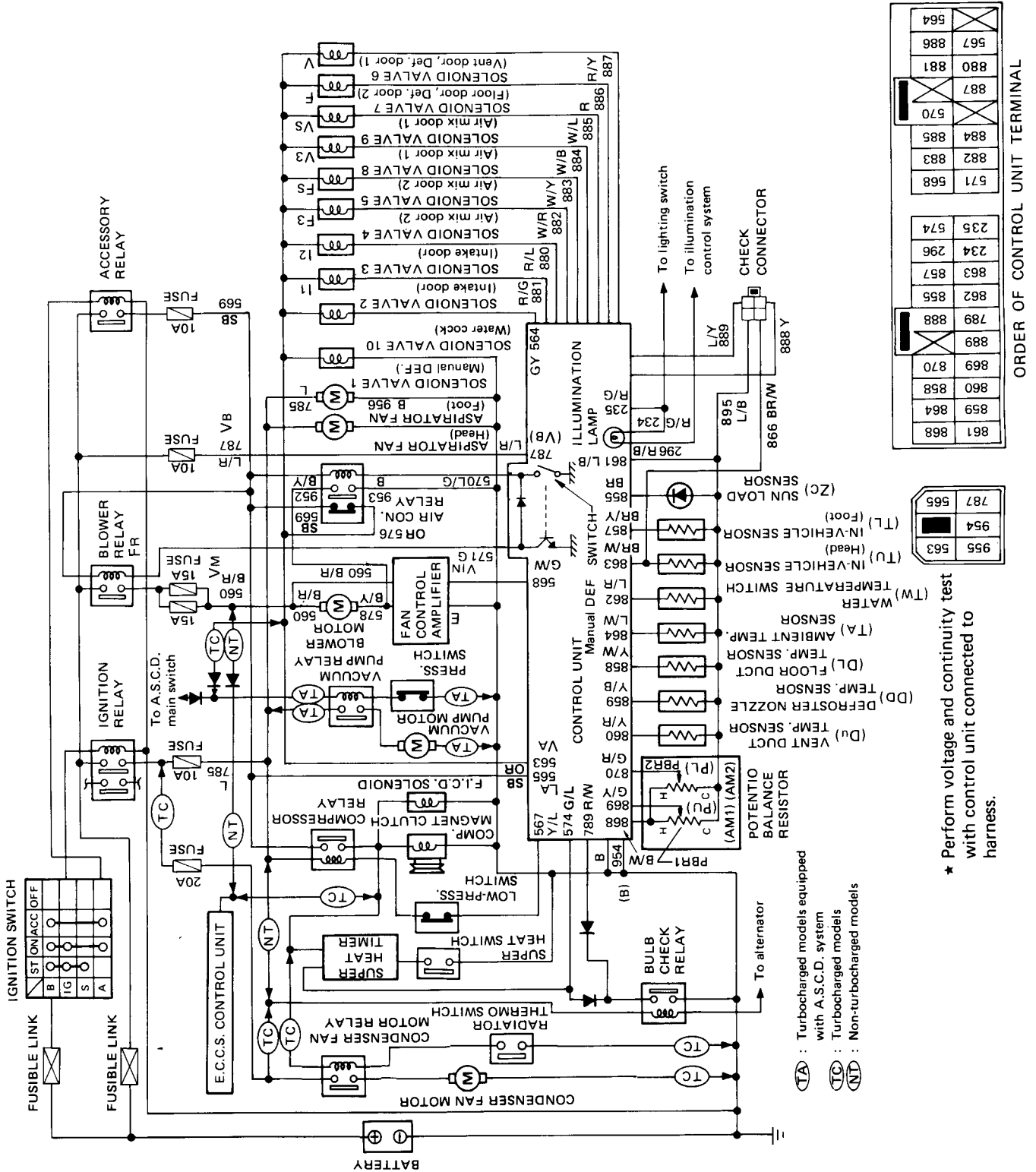

* Perform voltage and continuity test with control unit connected to harness.

- (TA) : Turbocharged models equipped with A.S.C.D. system
- (TC) : Turbocharged models
- (NT) : Non-turbocharged models

TROUBLE DIAGNOSES (Auto)

CONNECTOR INSPECTION POSITION AND TERMINAL ARRANGEMENT FOR DIAGNOSIS

Connectors are accessible for inspection after removing floor covers (left and right) and glove box.

NO	COLOR	NOTE	NO	COLOR	NOTE	NO	COLOR	NOTE	NO	COLOR	NOTE
234	R/G	L2	785	L	ASP (+)	871	L/B	ES	875	L/B	ES
296	R/B	L1	786	L/W	L.C.R.	880	R/L	I2	876	L/B	ES
560	B/R	MOT (+)	787	L/R	VB	881	R/G	I1			
561	OR	A/C (+)	788	L/W	L.C.R.	882	W/R	F3			
562	SB	ACC	789	R/W	ENG-RE	883	W/Y	FS			
563	OR	V A	855	BR	ZC	884	W/B	V3			
564	GY	W/C	857	BR/Y	TL	885	W/L	VS			
565	SB	LA	858	Y/W	DL	886	R	FL			
566	OR	A/C (+)	859	Y/B	DD	887	R/Y	V			
567	Y/L	CR	860	Y/R	DU	888	Y	ST			
568	G/W	V F	861	L/B	ES	889	L/Y	T2			
569	SB	ACC	862	L/R	TW	890	L/B	ES			
570	L/G	EM-SW	863	BR/W	TU	894	L/B	ES			
571	G	FR	864	L/W	TA	895	L/B	ES			
572	Y/G	SH-SW (+)	865	Y/G	VAC-P-R	952	B	MOT (-)			
573	G/B	SH-SW	866	BR/W	(Tu)	953	B	A/C-R			
574	G/L	GA	867	OR	SOL (+)	954	B	E1			
575	G/L	DIODE-BOX	868	B/W	VC	956	B	ASP (-)			
578	B/Y	MOT (-)	869	G/Y	PU	957	B	S-H-SW			
784	OR	W/C (+)	870	G/R	PL	958	B	SOL (-)			

TROUBLE DIAGNOSES (Auto)

AUTO A/C SYSTEM DIAGNOSIS

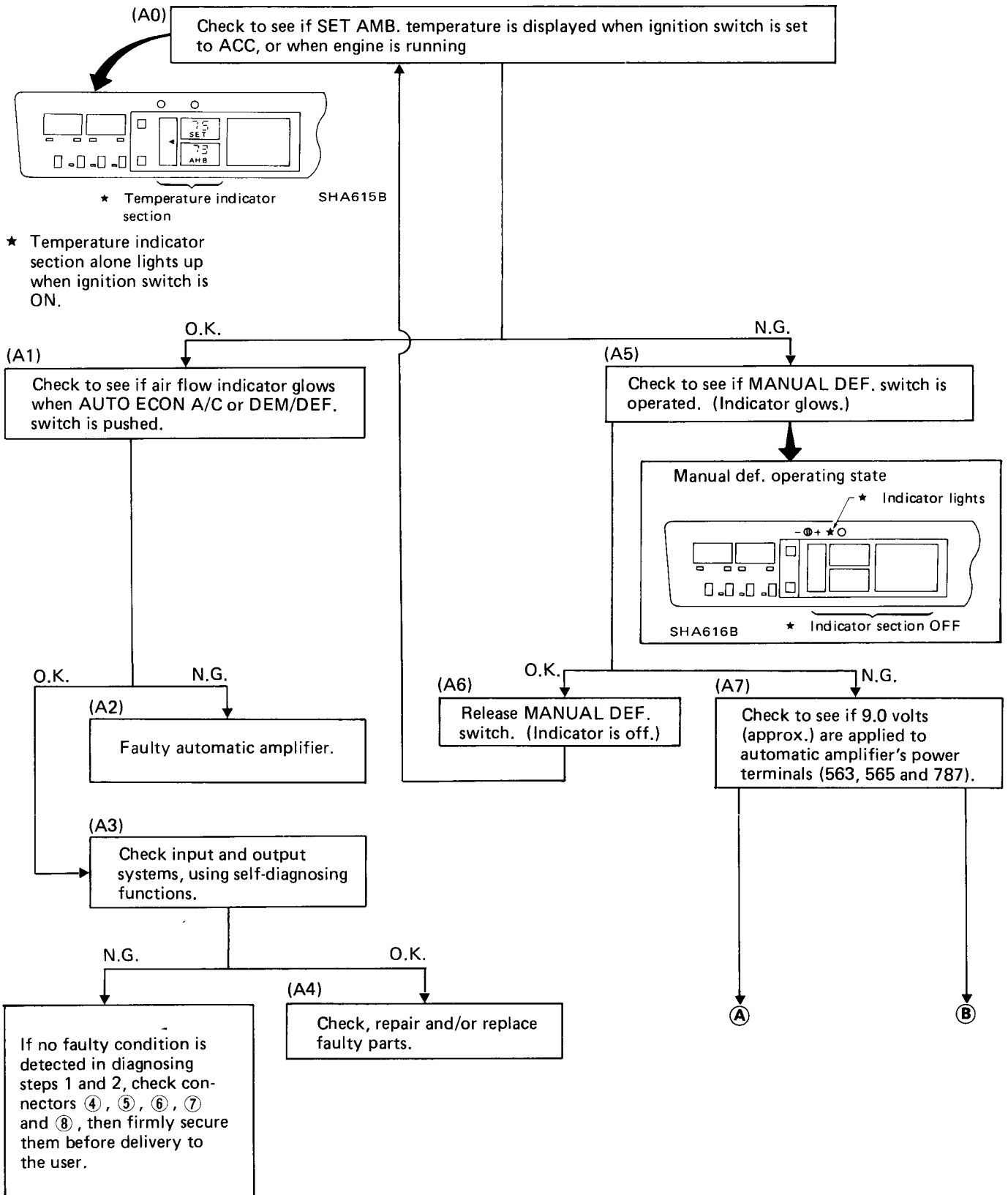

TROUBLE DIAGNOSES (Auto)

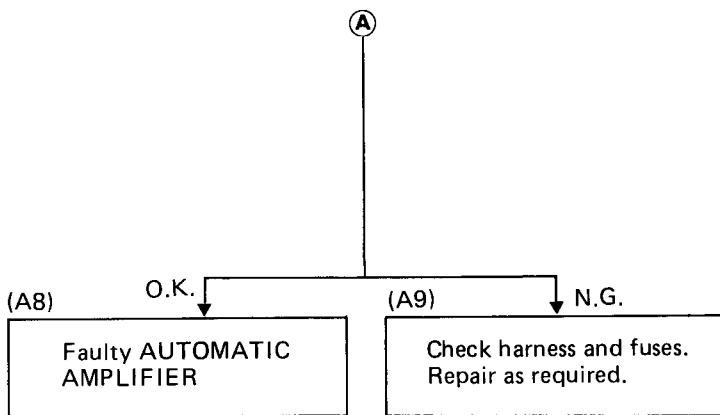

Inspection procedure:
Refer to Connector arrangement diagrams ① to ⑳ shown in HA-107.

1. Inspection of connectors ⑦ and ⑧, located near the cooling unit, to heater unit connecting section.
 - (1) Disconnect the connector and check the voltage at terminals 563, 565 and 787 on the cooling unit side. (Voltage must be greater than 9 volts.)

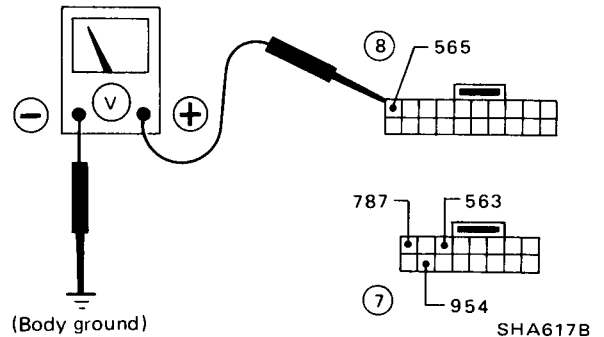

- (2) Check the voltage of terminal 954. (Voltage must be 0 volt.)

2.
 - (1) If the result of inspection 1 above is no good, check the fuse of ACC Vb in the fuse box.
 - (2) If the result of inspection 1 above is O.K., connect connectors ⑦ and ⑧ and disconnect connector ④ on the rear side of the control unit.

565	□	563
787	954	955

Check the voltage of terminals 563 (OR), 565 (SB), 787 (L/B), 954 (B) and 955 (B).

If it is difficult to check with connectors ⑦ and ⑧ connected, this inspection may be substituted with the continuity check between connectors ⑦ and ⑧ and connector ④.

3.
 - (1) If the result of inspection 2 above is no good, continuity of the harness between connectors ⑦ and ⑧ and connector ④ is faulty.
 - (2) If the result of inspection is O.K., the control unit is faulty.

TROUBLE DIAGNOSES (Auto)

INPUT SYSTEM DIAGNOSIS

★Numbers displayed on indicators.
When the indicator at I-0 thru I-4 shows only -17 [1], check line 861 (sensor ground = 0 V).

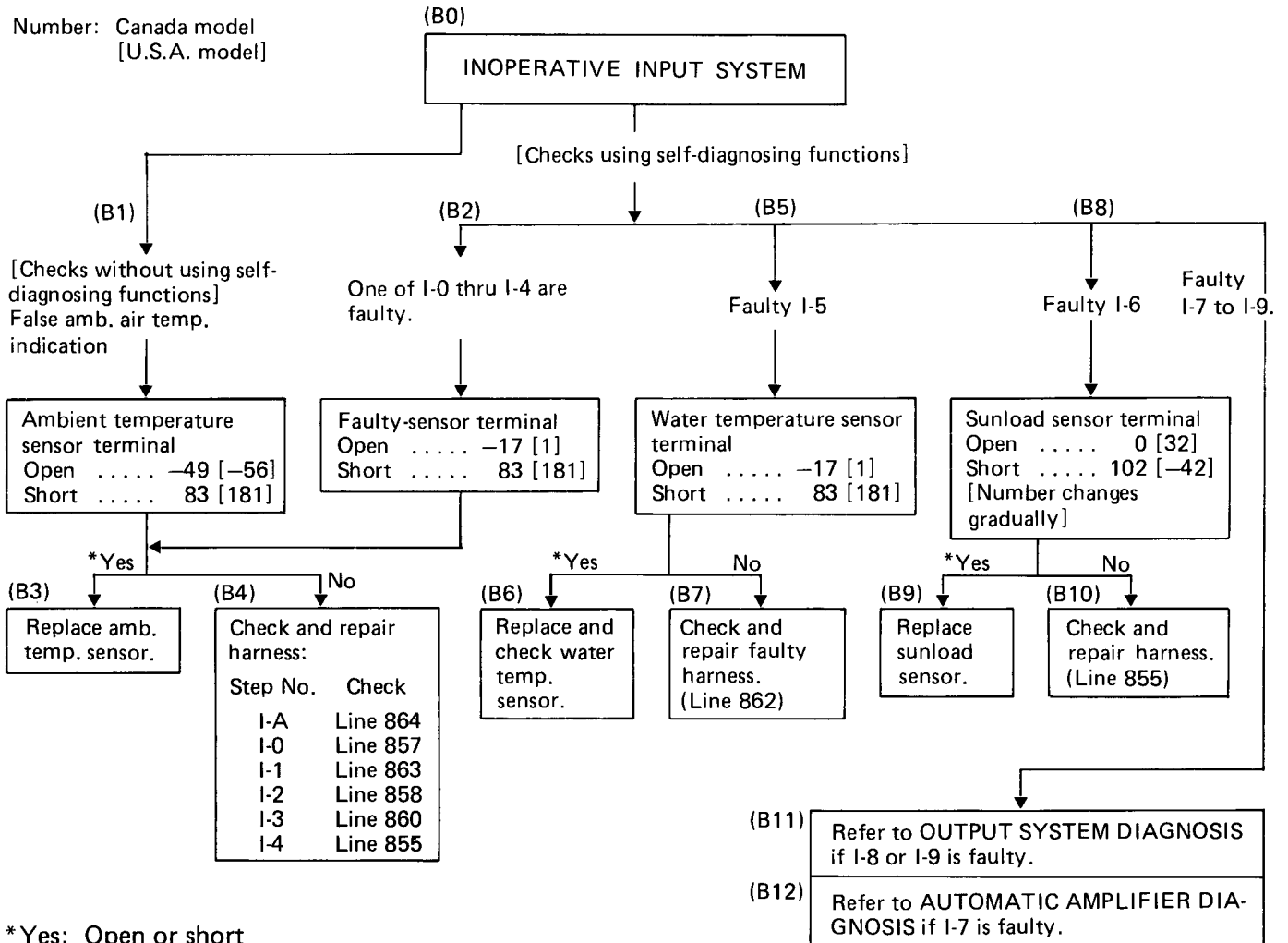

INSPECTION PROCEDURE

Conduct inspection referring to connector arrangement diagram on page HA-107.

Procedure 1

- (1) If AMB display on the control panel is faulty, disconnect the ambient temperature sensor connector from the front bumper. If the display is -49°C (-56°F) when disconnected, and 83°C (181°F) when the harness side is shorted, the auto amplifier and harness are O.K., but the AMB sensor is faulty. (Check the sensor for temperature-resistance characteristics.)
- (2) If the display does not change from -49°C (-56°F) even when shorted, the connection of 864 line (L/W) is faulty.

TROUBLE DIAGNOSES (Auto)

Procedure 2

- (1) ● If display of I – 0 is faulty, disconnect the connector (16); if the display while disconnected is -17°C (2°F), shortcircuit terminals 857 (BR/Y) and 894 (L/B). If 83°C (181°F) is indicated, the auto amplifier and harness are O.K.
 - If the indication is faulty, continuity of the harness between the connector (16) and foot-level sensor is poor, or the sensor is faulty. (Check sensor temperature-resistance characteristics.)
 - If the result of the above test is O.K., check the aspirator motor operation.
- (2) ● If the display of I – 1 is faulty, disconnect the connector (1); if it is -17°C (2°F) with the connector disconnected, and 83°C (181°F) when male terminals 863 (BR/W) and 861 (L/B) are shorted, then the connection of the auto amplifier and harness is O.K.
 - If the display does not indicate the above values, continuity of the harness between the connector (1) and head-level in-vehicle sensor is poor, or the sensor is faulty. (Check the sensor for temperature-resistance characteristics.)
 - If the above checks are all O.K., check operation of the aspirator motor and condition of air seal.
- (3) ● If the display of I – 2 and I – 3 is faulty, perform similar checks on the connectors (10) and (11). (Check the harness side connector for open or short.)
- (4) ● If the display of I – 4 is faulty, check the connector (17) for open or short between female terminals 859 (Y/B) and 890 (L/B).

Procedure 5

- Disconnect the water temperature switch of the water cock mounted in the engine compartment. Check the harness for open or short.

Procedure 8

- If 0 (32) is displayed with the connector (17) removed, the harness connection is O.K.
- Move the vehicle into the sun and disconnect the connector. Then, check for change in current value between male terminals 855 (BR) and 890 (L/B).
- ★ **In fine weather: If the output is on the order of mA and it drops to 0 mA when the sunload sensor is covered, the display is normal.**

TROUBLE DIAGNOSES (Auto)

OUTPUT SYSTEM DIAGNOSIS

1) Inoperative air mix door

INSPECTION PROCEDURE – Air Mix Door

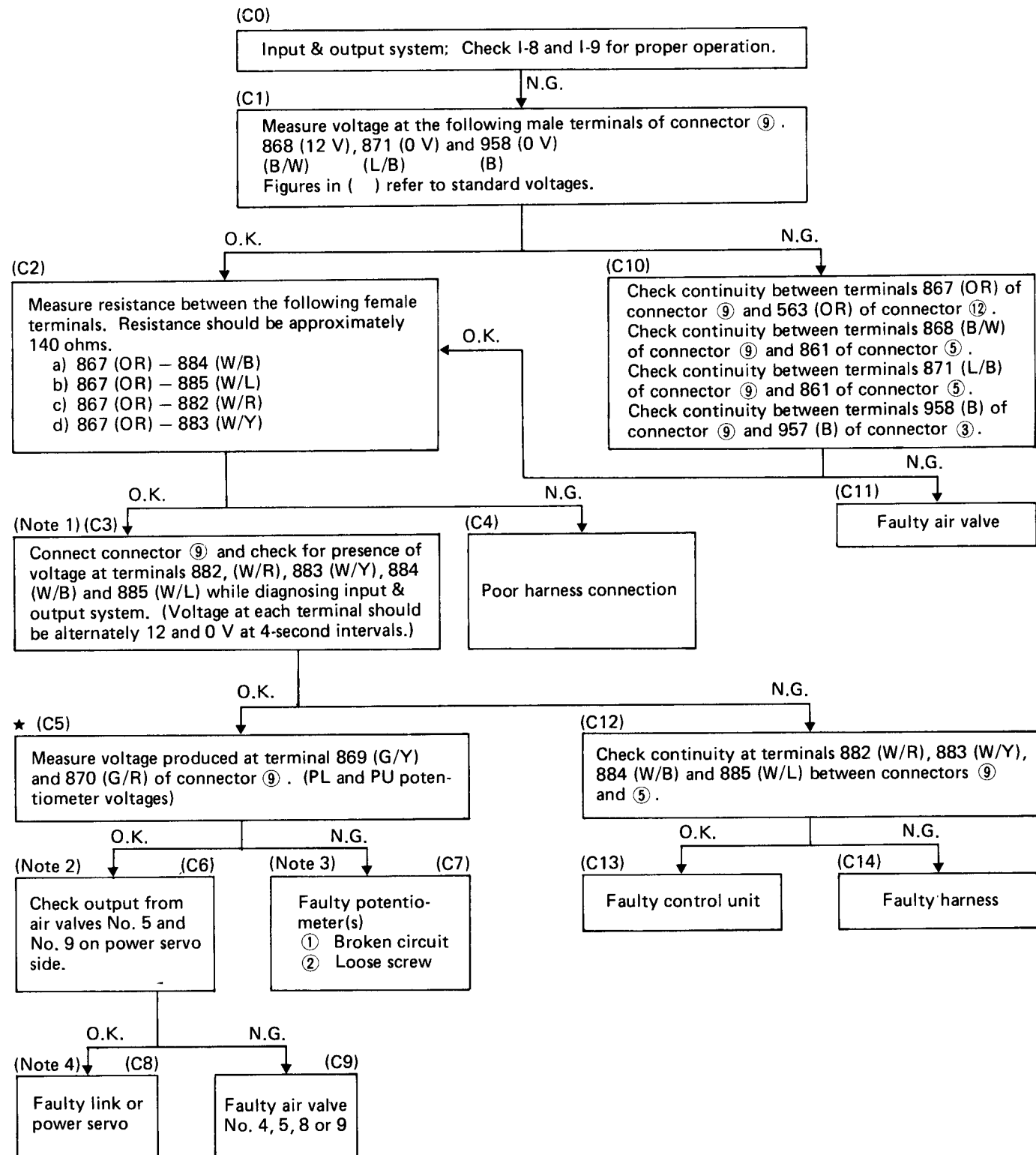

TROUBLE DIAGNOSES (Auto)

INSPECTION PROCEDURE

Use layout of connectors ① through ⑳ on page HA-107 as an inspection guide.

- (Note 1) Check while starting engine and diagnosing input & output system.
- (Note 2) Same as Note 1 above. Faulty input vacuum line can be determined by fixed DEF mode.
- (Note 3) After disconnecting vacuum hose from air valve No. 5 or No. 9, connect vacuum hose (on hand) to the hose. Suck air from and blow air into hose orally or by using a vacuum pump and check if potentiometer reading varies with changes in air temperature. If potentiometer reading does not change, link may be jammed, power servo may not be installed properly (loose screws, etc.) or power servo may be faulty.
- (Note 4) In a manner similar to Note 3 above, disconnect vacuum hose from air valve No. 5 or No. 9 and connect vacuum hose (on hand) to the hose. Suck air from and blow air into hose orally or by using a vacuum pump. If air temperature does not change regardless of control operation of photo amplifier for power servo, link may be jammed, power servo may be installed improperly (loose screws, etc.) or power servo is not functioning.
- Other If air valves constantly repeat ON-OFF operation when ATC and input & output system function properly, air valve(s) may be leaking.
- ★ Performance characteristics of PL and PU-potentiometer voltages and input indications (#8 and 9)

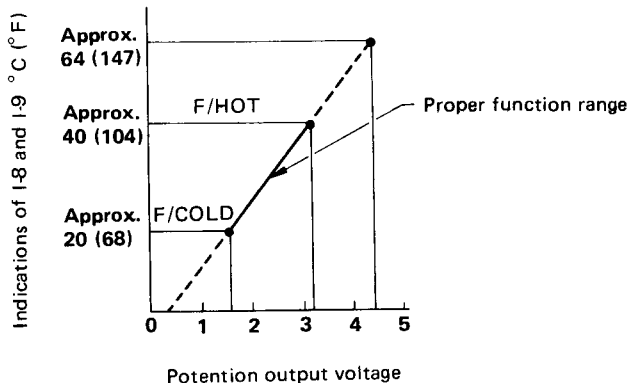

SHA618B

TROUBLE DIAGNOSES (Auto)

2) Doors, water cock and compressor diagnosis

While checking input, output system, check solenoid valves, relays, vacuum pressure, etc., using the following tables as a guide.

Normal solenoid valve and relay operation

Positive (+) side: Approx. 12 V (Constant)

Negative (-) side: OFF (approx. 12 V)
ON (0 volts)

INSPECTION PROCEDURE – Doors, Water Cock and Compressor

Check operation of air valves and relays while inspecting input & output system.

Air valves and relays

Positive (+) side: Approximately 12 volts (constant)

Negative (-) side: Approximately 0 volts (OFF)

(Downstream of coil): Approximately 0 volts (ON)

★ Be careful not to short-circuit positive and negative sides of coil. Otherwise, transistor(s) inside control unit may be damaged.

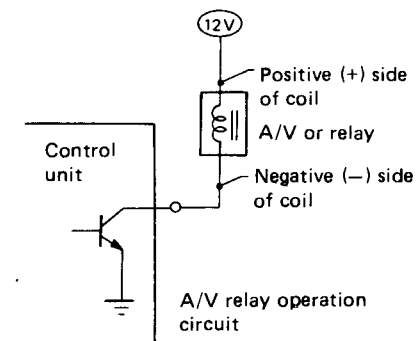

2-1 Inspection Procedure – Air Outlets

SHA619B

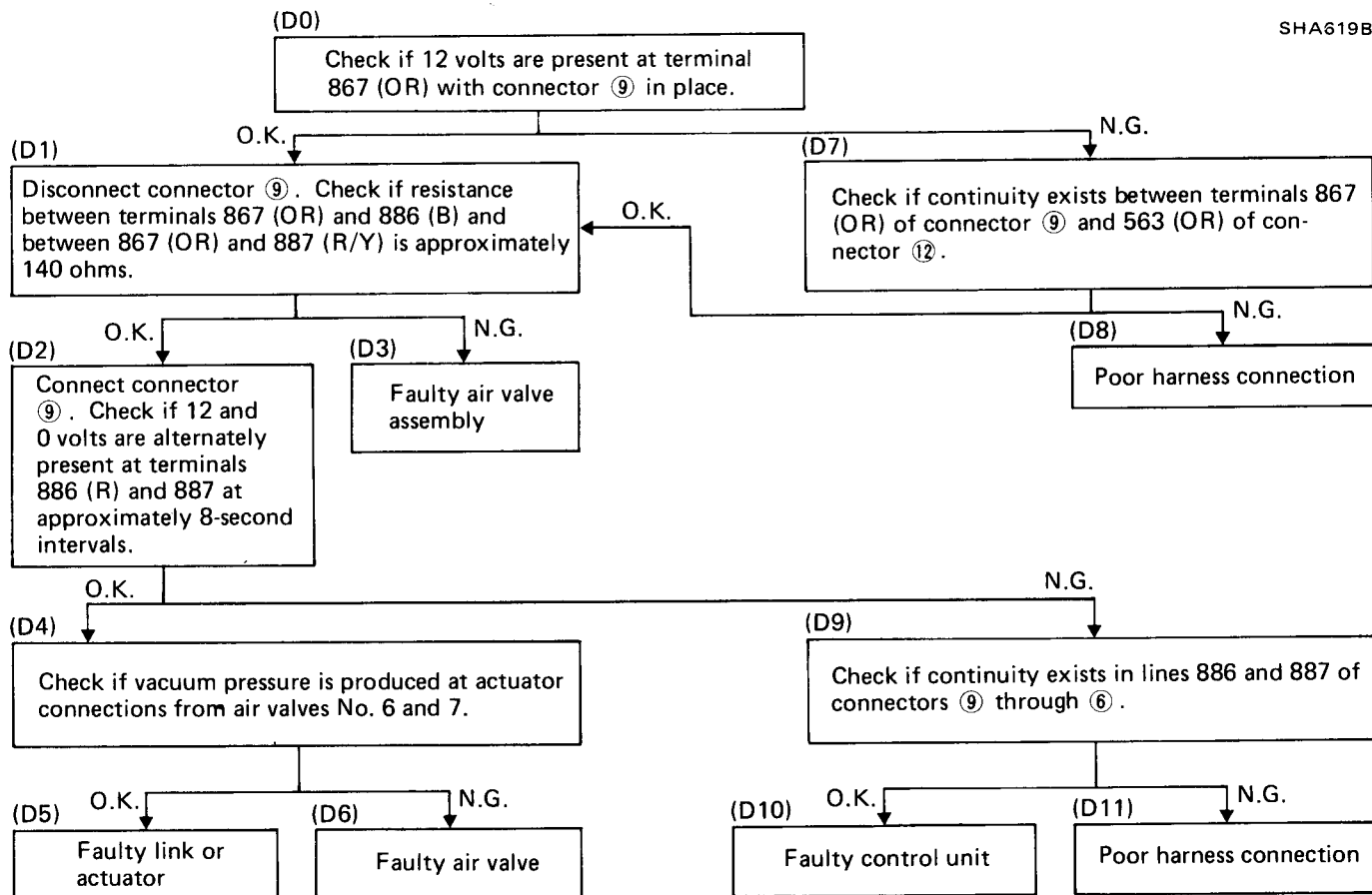

TROUBLE DIAGNOSES (Auto)

Mode Door Operation

		Air valve actuator		Air valve		Actuator		
		No. 6	No. 7	DEF door	VENT door	FLOOR door		
Mode	DEF	OFF	OFF	Atmospheric pressure				
	VENT	ON	OFF	Vacuum pressure			Atmospheric pressure	
	B/L	ON	ON	Vacuum pressure				
	HEAT	OFF	ON	Atmospheric pressure			Vacuum pressure	

2-2 Inspection Procedure – Intake Doors

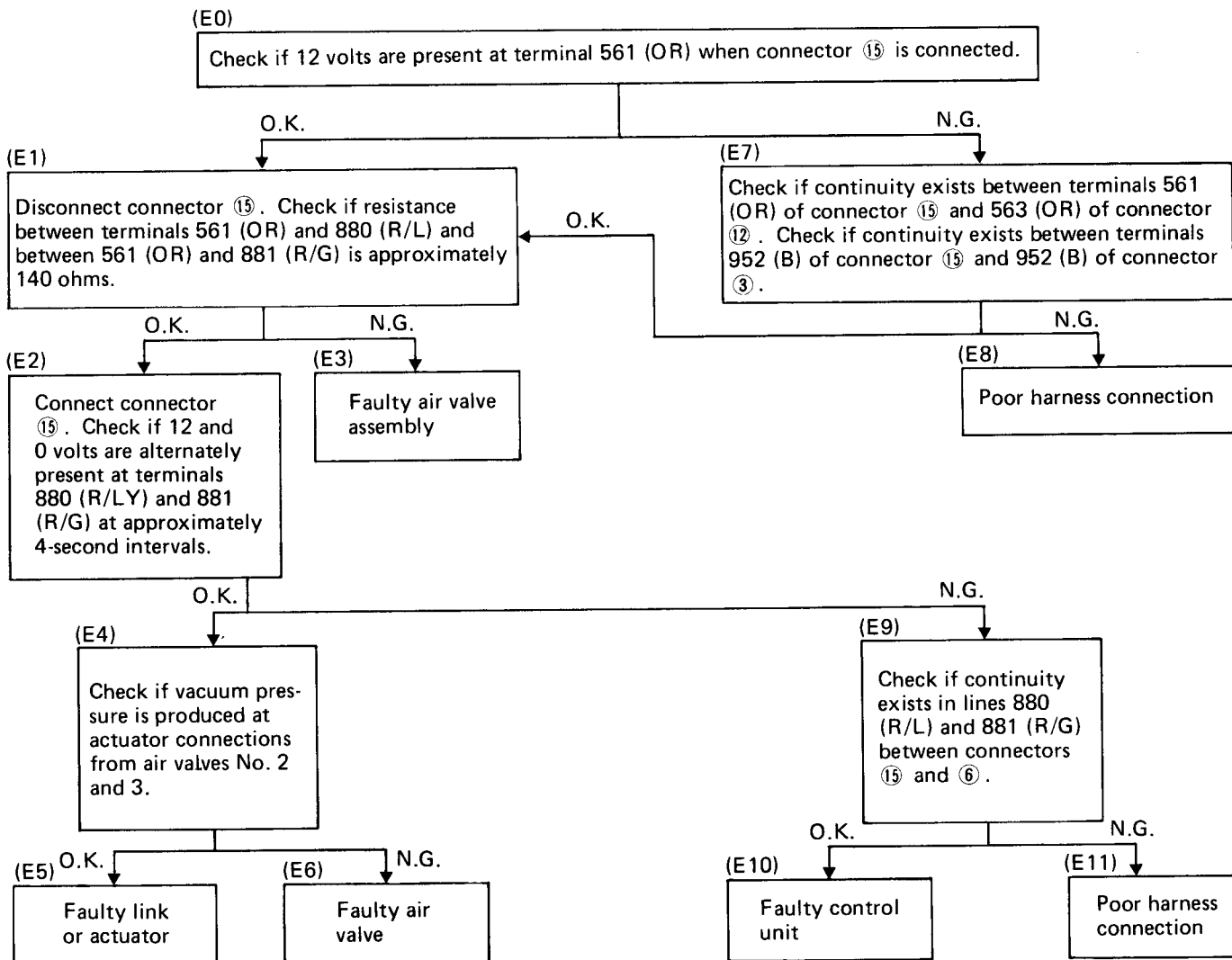

TROUBLE DIAGNOSES (Auto)

Intake Door Operation

Air valve actuator		Air valve No. 3	Air valve No. 2	Double-action actuator (intake door closed)
Mode	Inside air	ON	ON	Vacuum pressure (at 1st and 2nd positions)
Air inlet	Inside-outside air	ON	OFF	Vacuum pressure (at 1st position)
	Outside air	OFF	OFF	Atmospheric pressure

2-3 Inspection Procedure – Water Cock

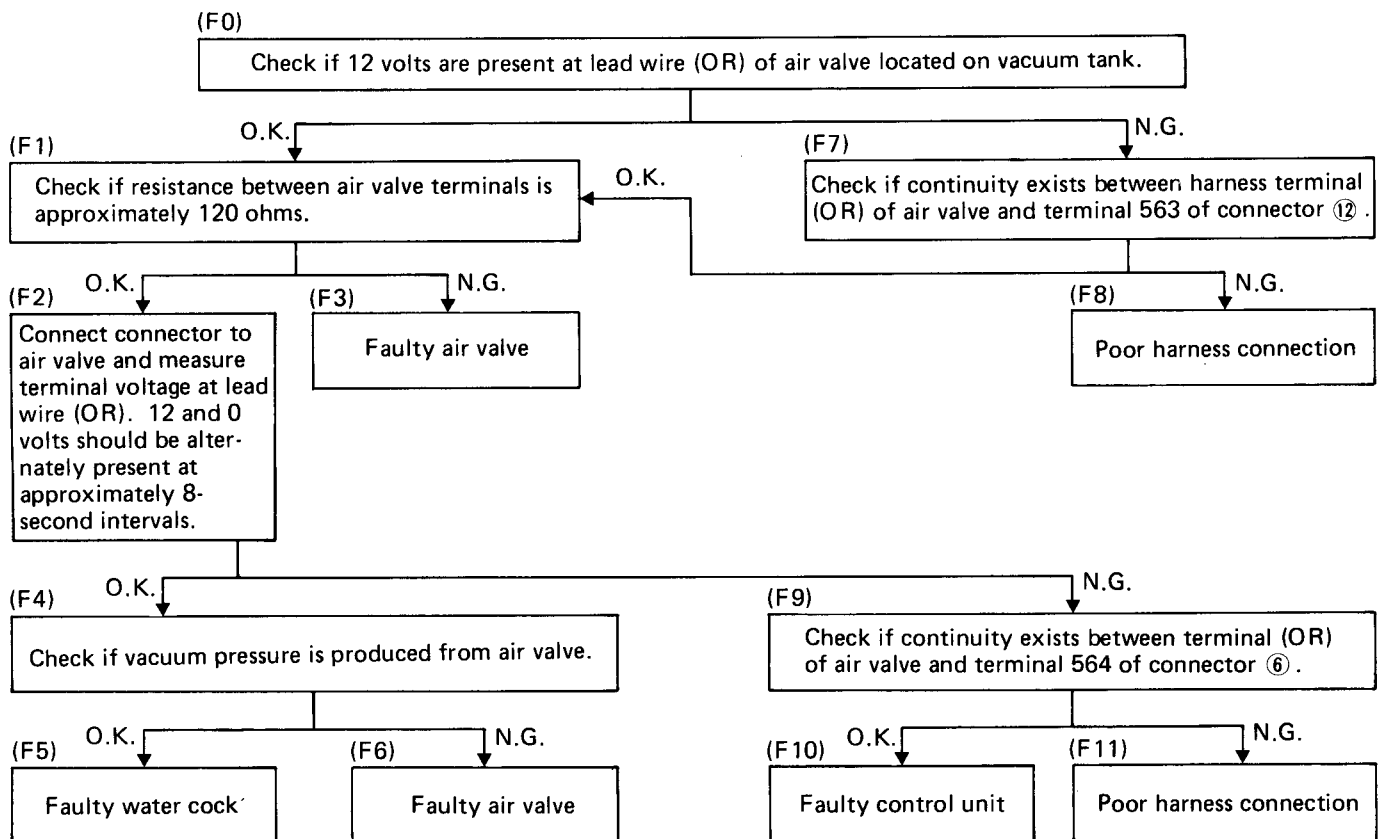

Water cock operation

Air valve actuator	Air valve	Water cock actuator
Water cock		
Open	OFF	Atmospheric pressure
Close	ON	Vacuum pressure

TROUBLE DIAGNOSES (Auto)

2-4 Inspection Procedure – Compressor

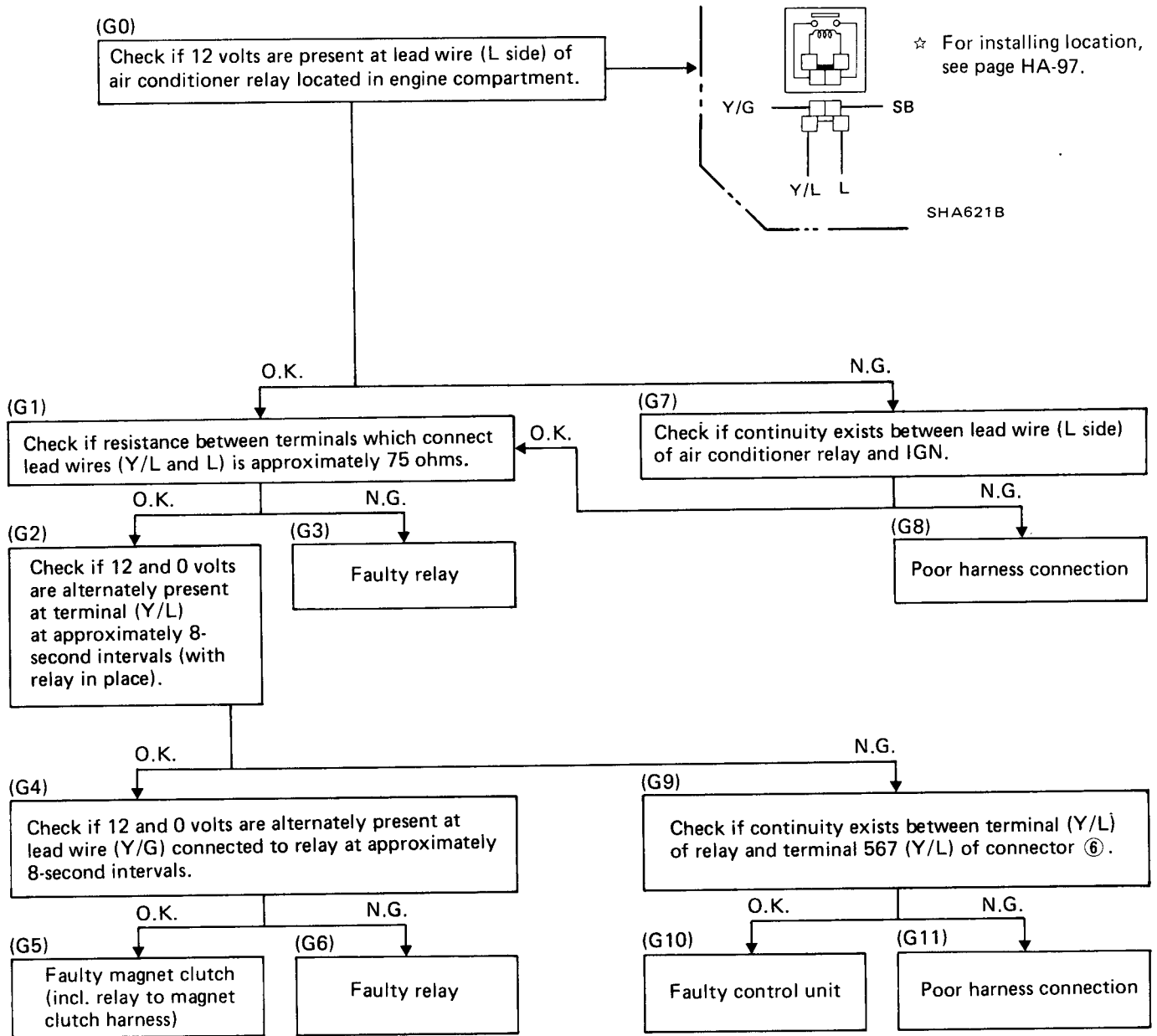

Compressor operation

/	Relay
Compressor ON	ON
Compressor OFF	OFF

TROUBLE DIAGNOSES (Auto)

3) Blower motor diagnosis

INSPECTION PROCEDURE – Blower & Motor

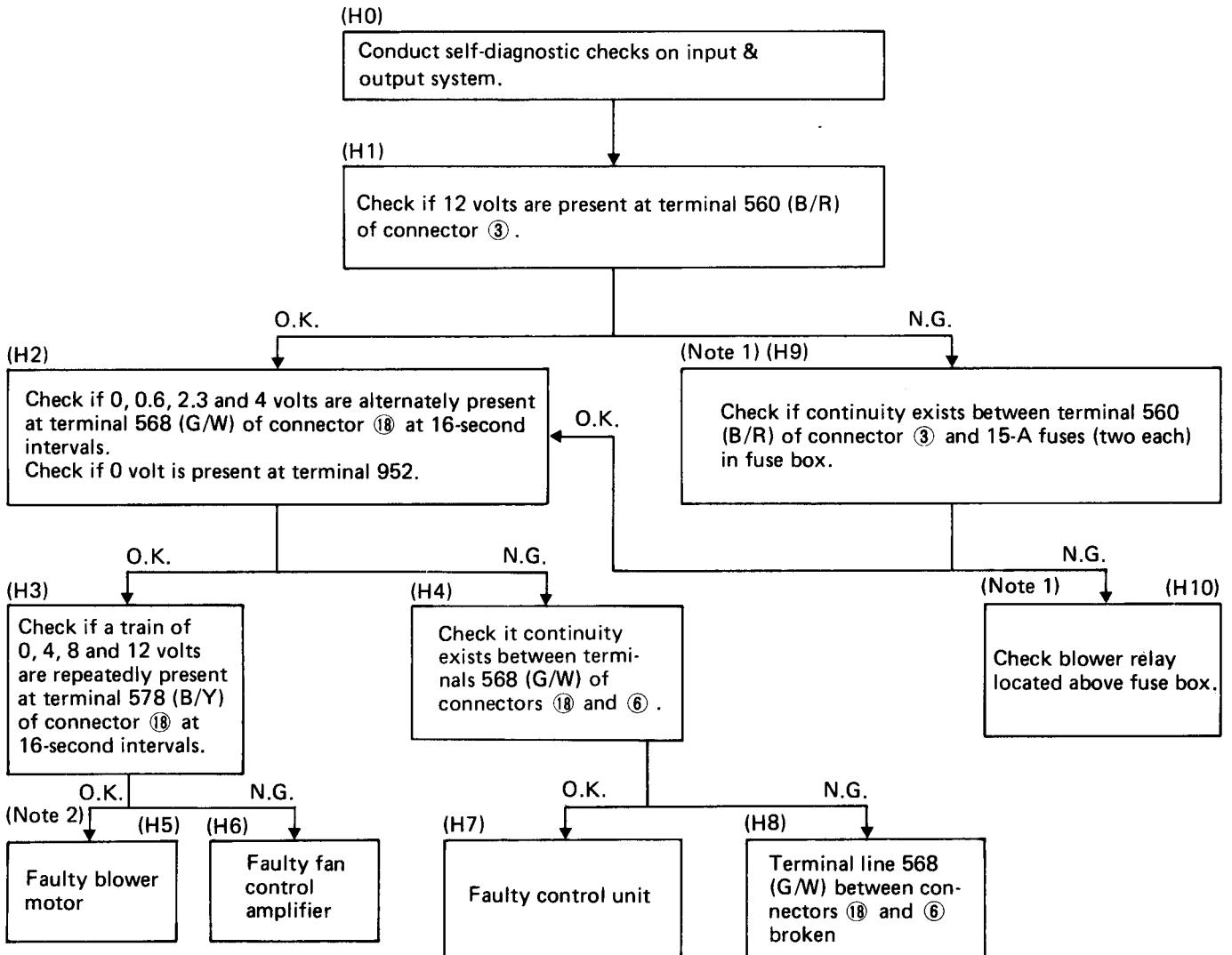

TROUBLE DIAGNOSES (Auto)

- (Note 1) When ignition switch is set to ACC, current flows through blower relay coil. With ignition switch held there, activating switches "AUTO", " " and "SW" on control unit causes downstream side of relay coil to be grounded so that blower relay activates. If blower motor does not activate due to problems in its power supply, it will be due to one of the following causes:
- (a) Lead wire (W) between fusible link and relay is broken,
 - (b) The line between lead wire (W/G) of relay and terminal 560 of connector ③ (including two 15-A fuses) is broken,
 - (c) The line between lead wire (S/B) of relay and fuse (ACC) is broken, or
 - (d) The line between lead wire (G) of relay and terminal 571 of connector ⑥ is broken.

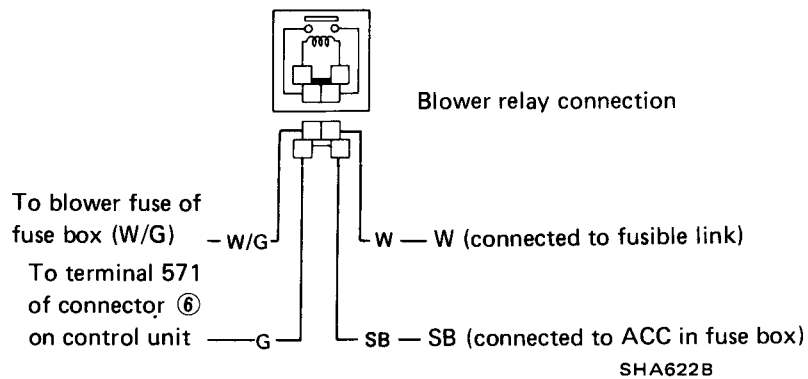

(Note 2) If blower starts when manual DEF switch is activated, problem is due to poor body ground of fan control amplifier.

(Note 3) Output performance characteristics of fan control is shown below.

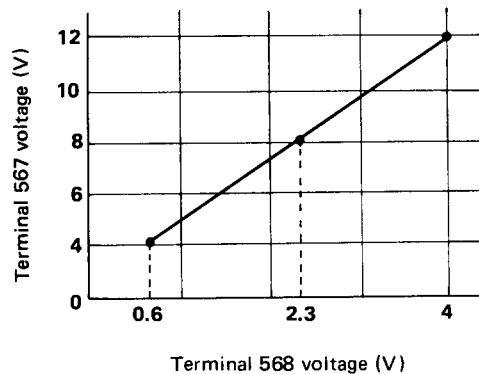

SHA620B

TROUBLE DIAGNOSES (Auto)

AUTOMATIC AMPLIFIER DIAGNOSIS

1) LCD (Liquid Crystal Display) or LED (Light Emitting Diode) does not glow.

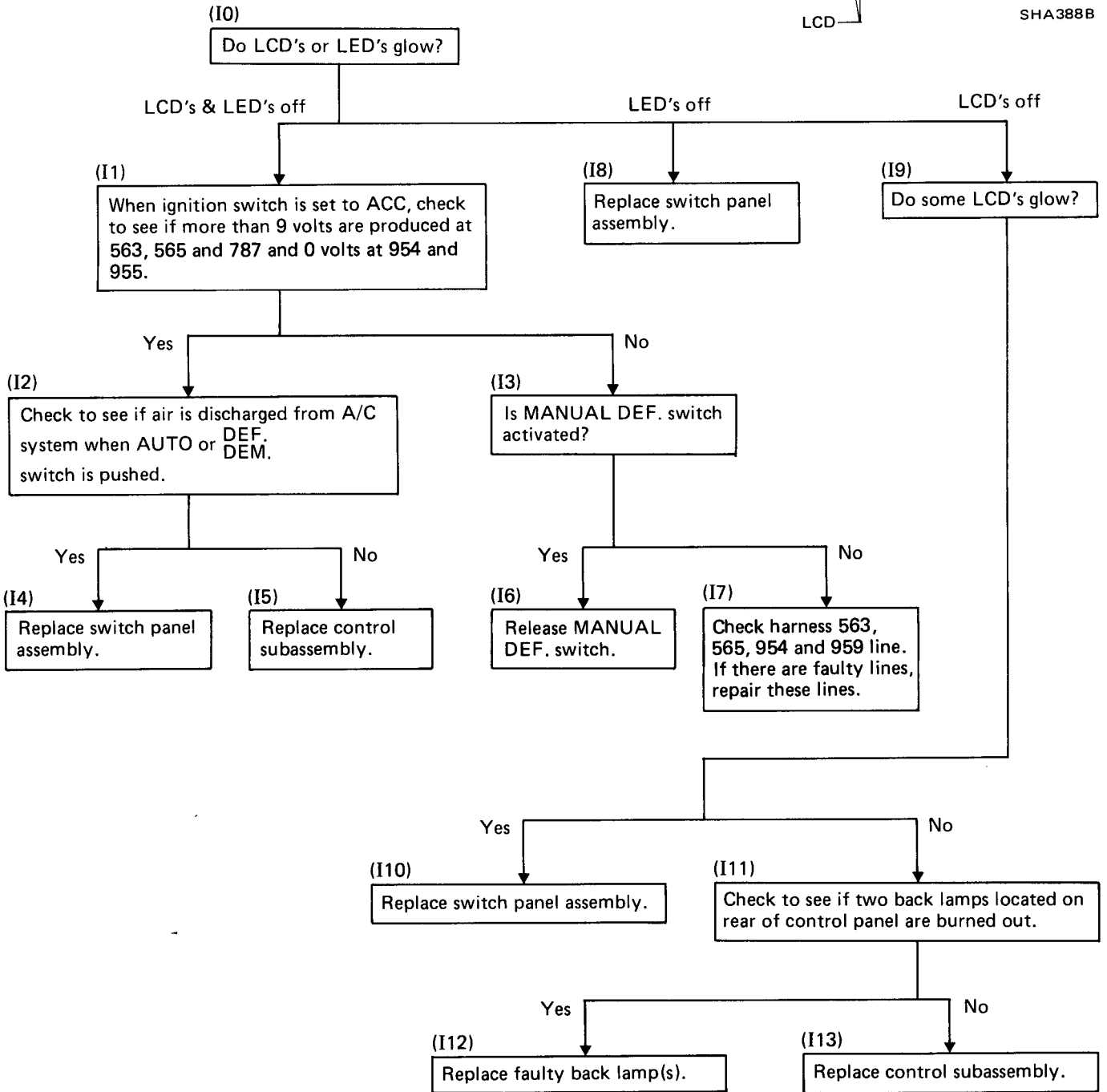
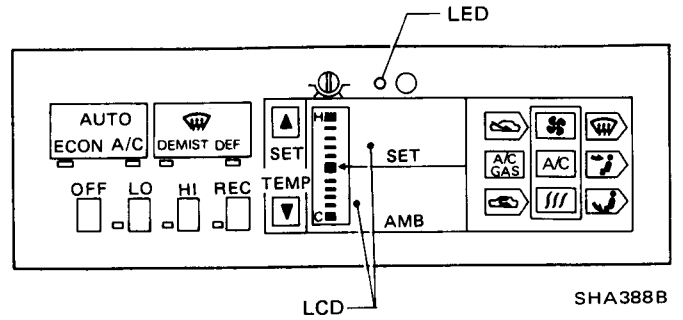

TROUBLE DIAGNOSES (Auto)

2) Operating (Buzzing) Sound is not Emitted.

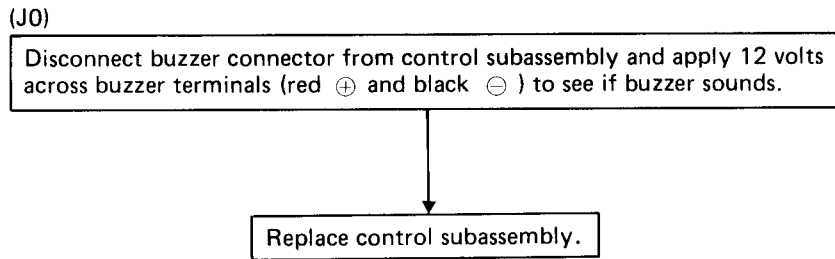

3) Switches on Switch Panel Assembly do not Operate.

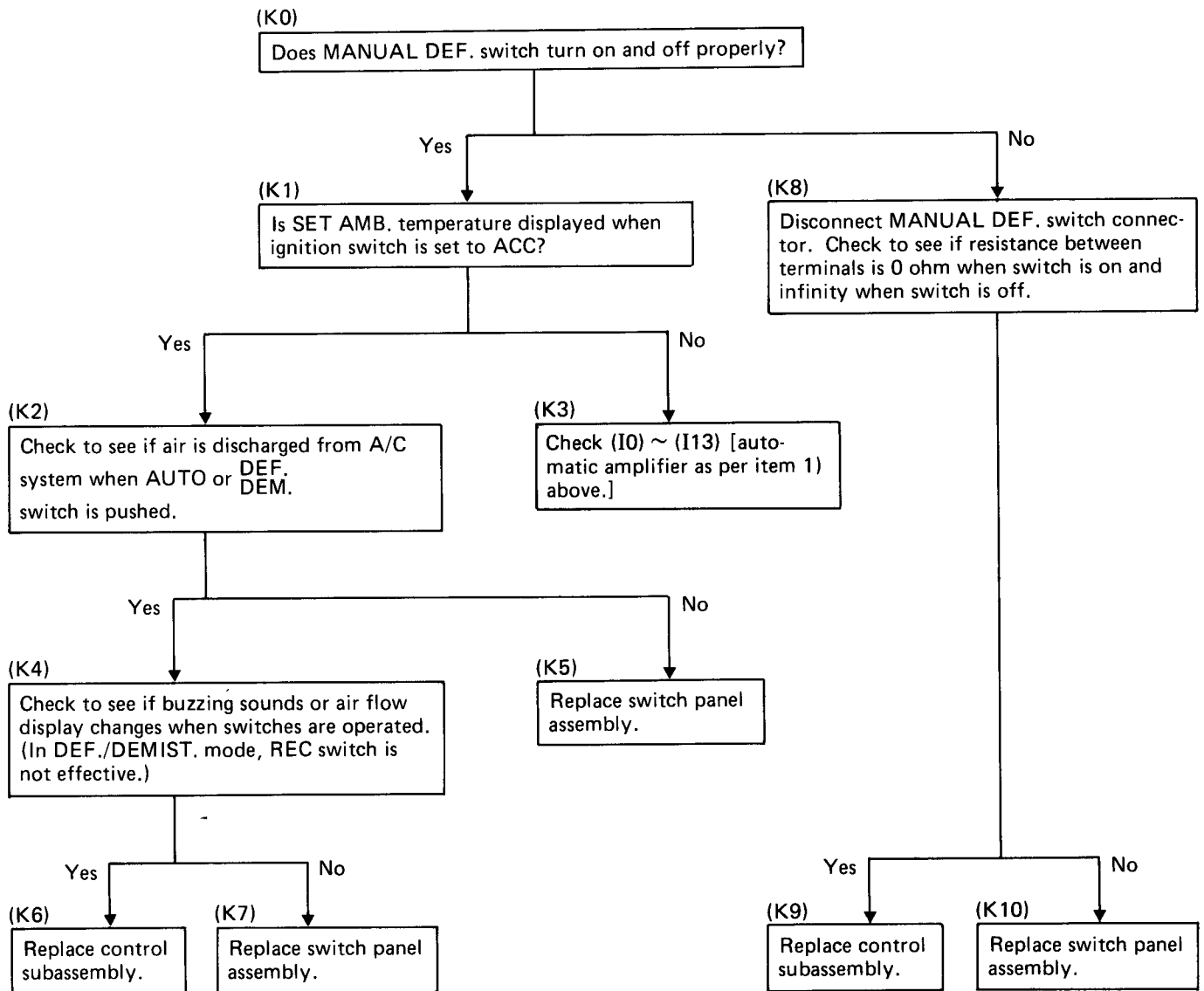

TROUBLE DIAGNOSES (Auto)

4) Erroneous Display during Inspection of the Input System

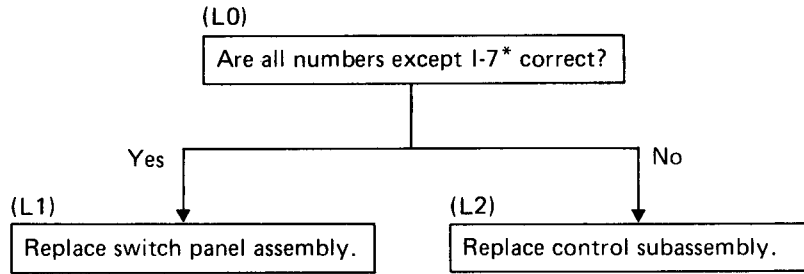

5) Erroneous Operation during Inspection of the Output System

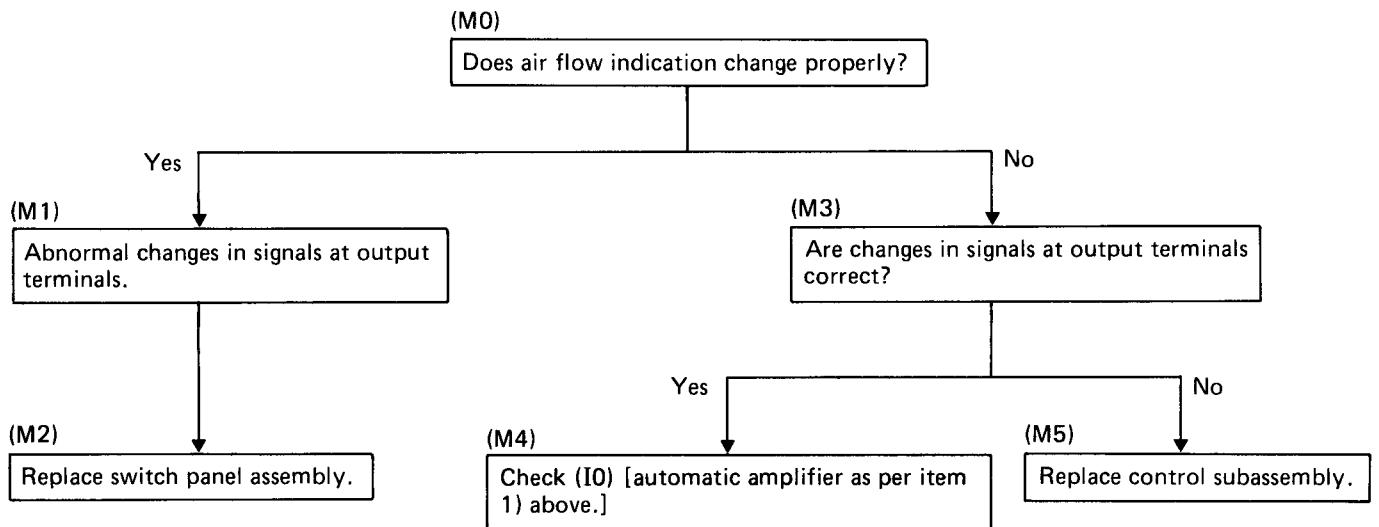

6) MANUAL DEF. indicator does not come on.

Replace switch panel assembly.

7) Escutcheon lamp does not come on.

Check for burned-out lamp located at rear of switch panel assembly.

TROUBLE DIAGNOSES (Auto)

REPLACEMENT OF CONTROL SUBASSEMBLY AND SWITCH PANEL ASSEMBLY

- * Before performing various operational checks of the automatic amplifier, check to make sure the four switch panel assembly-to-control subassembly connectors, MANUAL DEF. switch connector and buzzer connector are secure and tight and are free from damage.

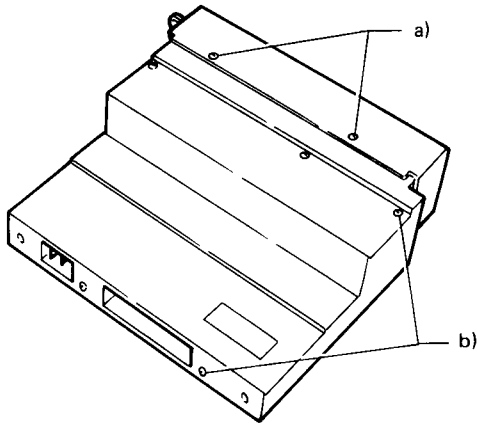

SHA385B

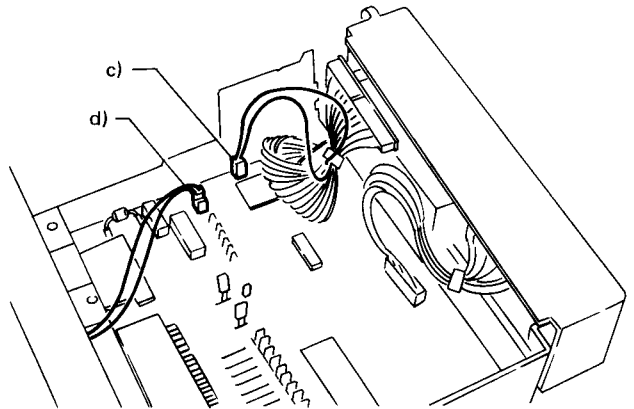

SHA386B

- a) M3 flat head screw, 2 places
- b) M3 panhead screw, 4 places
- c) MANUAL DEF. switch connector
- d) Buzzer connector

1. Remove the four flat phillips head screws a) on the panel assembly. Then remove the four phillips pan head screws b).
2. Pull the panel assembly forward about an inch, then remove the top steel plate. When removing the steel plate, caution should be observed. A buzzer is connected to the plate with a lead wire running to a connector on the printed circuit board. Carefully disconnect the buzzer lead at the printed circuit board connector by prying the plastic lock retainer away from the wire's electrical connector.
3. To separate the subassembly from the panel, unplug the five harness leads leading from the control panel at the printed circuit board connector. Then replace assembly components as required.
4. On the rear of the control panel assembly are five light bulbs that can be serviced as required.

TROUBLE DIAGNOSES (Auto)

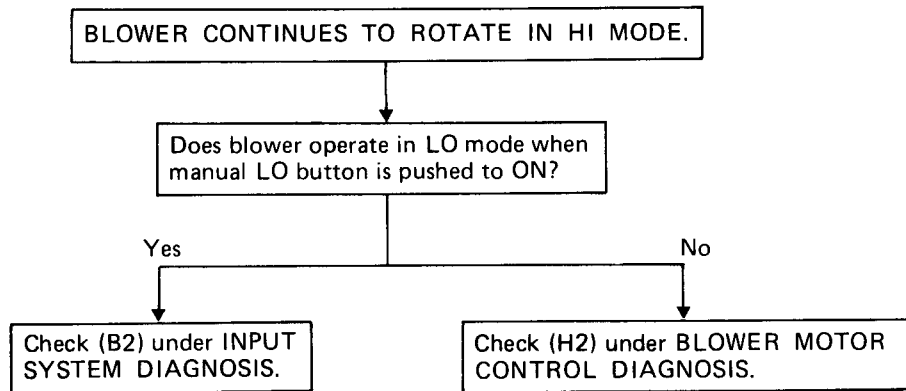

[CHECK POINTS]

- (1) Open or shorted sensor (Tu, Du, or Dd)
- (2) Aspirator motor does not rotate and "Tu" value is close to "TA" value.

TU: In-vehicle sensor (Head)
TA: Ambient temp. sensor

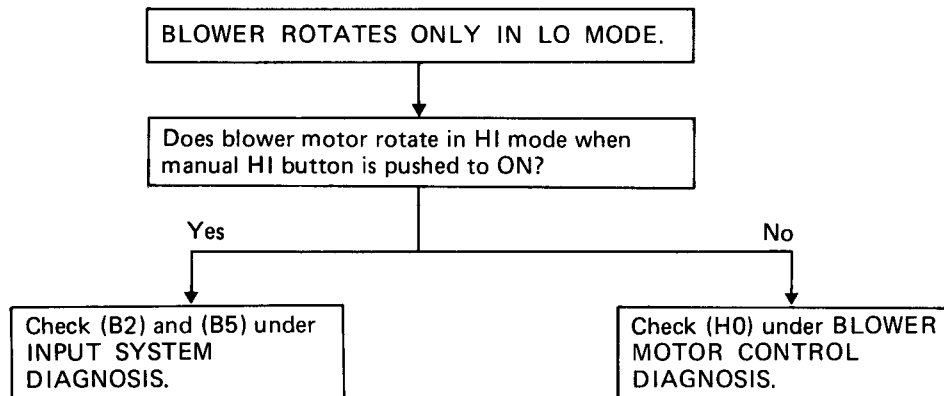

[CHECK POINTS]

Harnesses, connectors and sensors in relation to TL, Tu, DL, Du, Dd

TL: In-vehicle sensor (Foot)
TU: In-vehicle sensor (Head)
DL: Floor duct temp. sensor
Du: Vent duct temp. sensor
Dd: Defroster nozzle temp. sensor

TROUBLE DIAGNOSES (Auto)

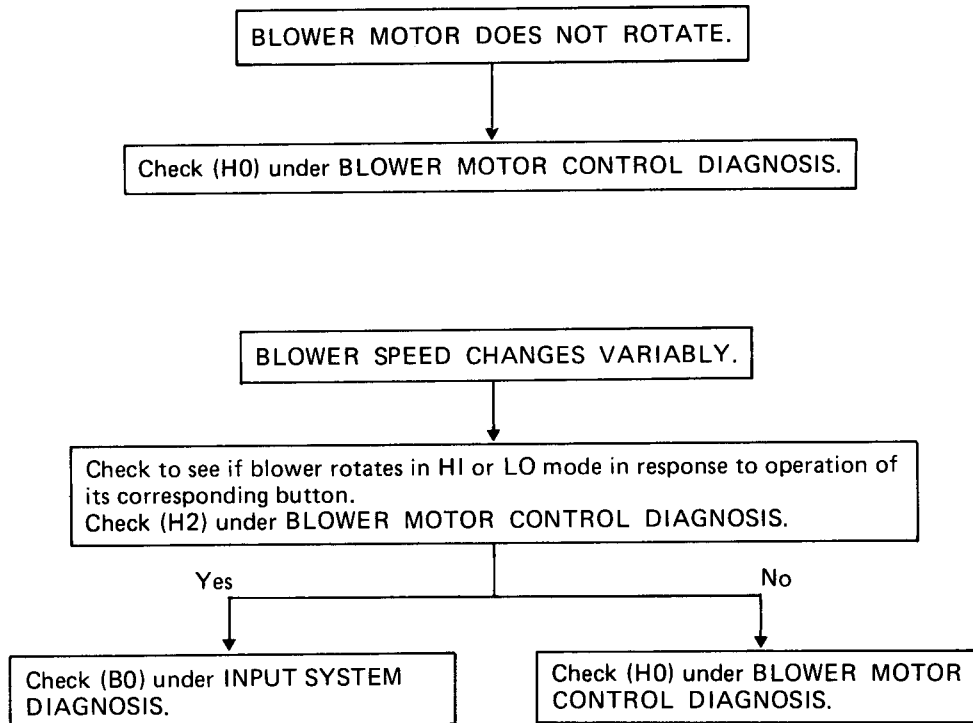

[CHECK POINTS]

- (1) Poor or faulty connection of In-vehicle sensor (Foot), In-vehicle sensor (Head), Floor duct temp. sensor, Vent duct temp. sensor, Defroster nozzle duct temp. sensor, Ambient temp. sensor, Sunload sensor, Potentio Balance Resistor (AM1), Potentio Balance Resistor (AM2).
- (2) Start-stop operation of aspirator motor and voltage measurements at sensors (Remove sensor assembly to gain access to sensors.)

TROUBLE DIAGNOSES (Auto)

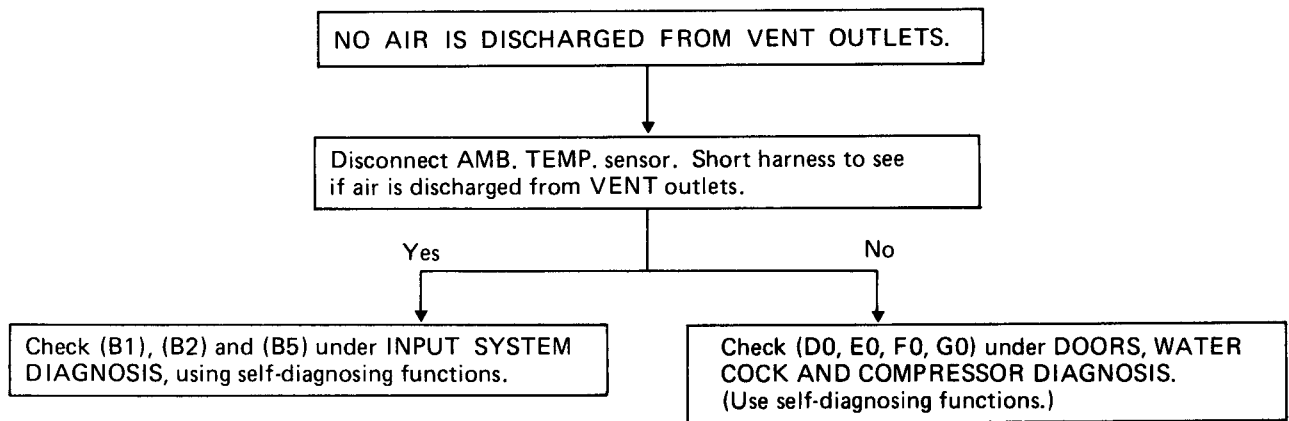

[CHECK POINTS]

(1) Open circuit in TA, TL, Tu and DL sensors.

TA: Ambient temp. sensor
TL: In-vehicle sensor (Foot)
TU: In-vehicle sensor (Head)
DL: Floor duct temp. sensor

[CHECK POINT]

(1) Harness (line 887), solenoid valve, etc.
(2) Damage to hose between solenoid valve (6) and actuator air valve, or condition of link system affected.

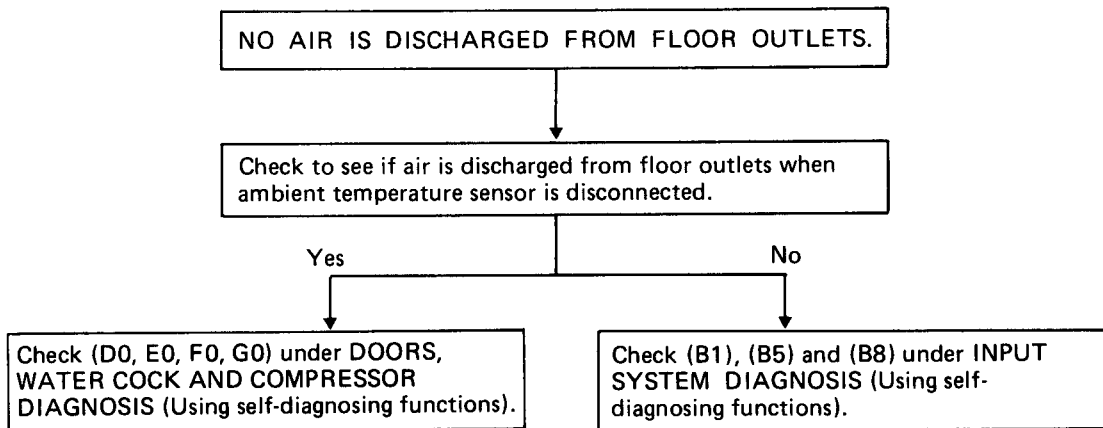

[CHECK POINTS]

Short circuit in ambient temp. sensor and sunload sensor

[CHECK POINTS]

(1) Harness (line 886) and solenoid valve (7)
(2) Damage to hose between solenoid valve (7) and floor actuator Af, and condition of link system affected

TROUBLE DIAGNOSES (Auto)

NO AIR IS DISCHARGED FROM DEFROSTER OUTLETS.



Check (D0, E0, F0, G0) under OUTPUT SYSTEM DIAGNOSIS
(Use self-diagnosing functions).

[CHECK POINTS]

- (1) Harness (line 887) and solenoid valve 6
- (2) Damaged hose/link between solenoid valve 6 and actuator Ad (DEF. door Actuator)

HOT AIR IS NOT DISCHARGED OR OUTLET
AIR TEMPERATURE DOES NOT CHANGE.



Check input system using self-diagnosing functions.

N.G.

O.K.

Check (B2) and (B5) under INPUT
SYSTEM DIAGNOSIS.

Check OUTPUT SYSTEM DIAGNOSIS:
Air mix door (C0)
Water cock (F0)

TROUBLE DIAGNOSES (Auto)

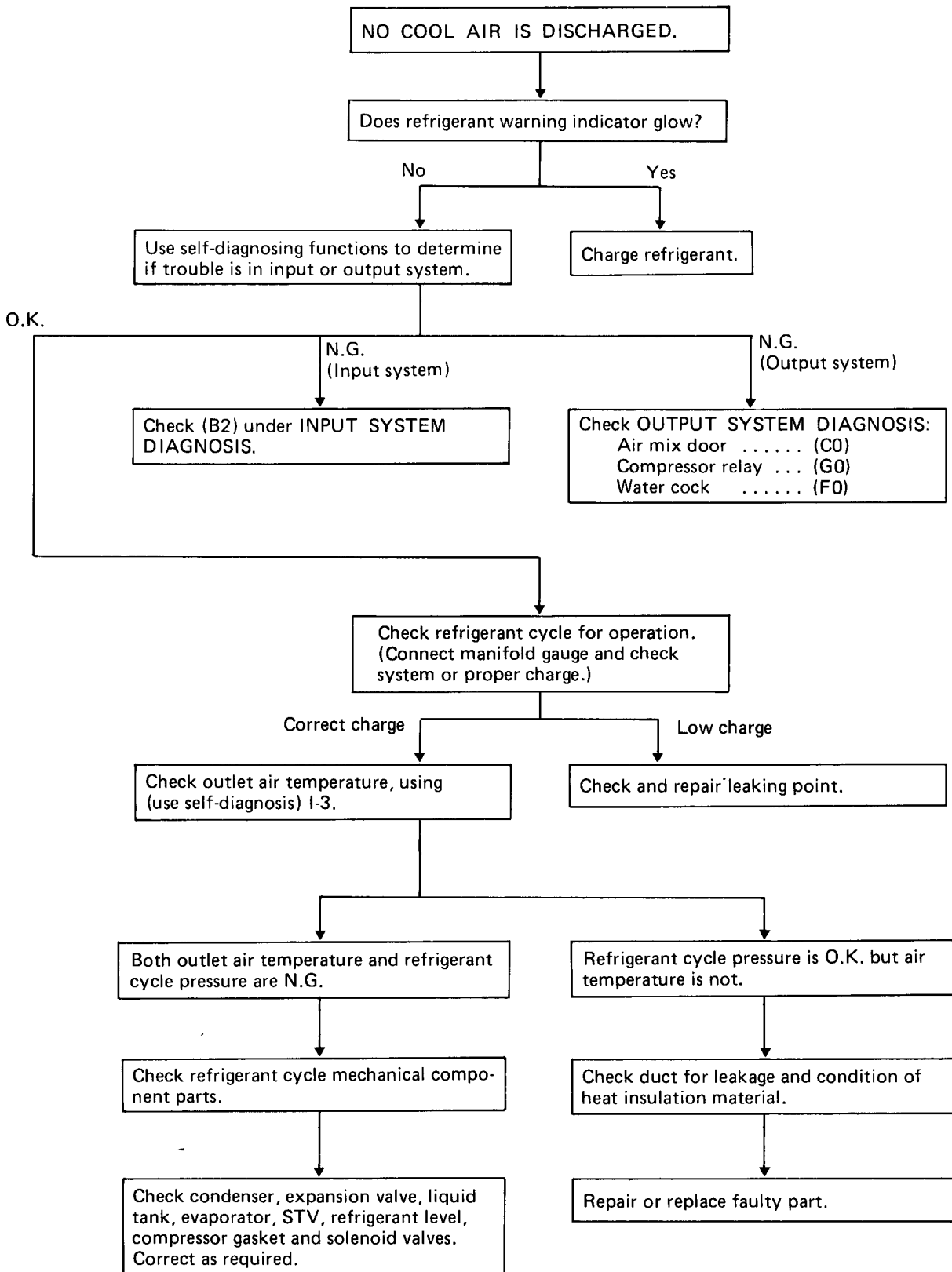

TROUBLE DIAGNOSES (Auto)

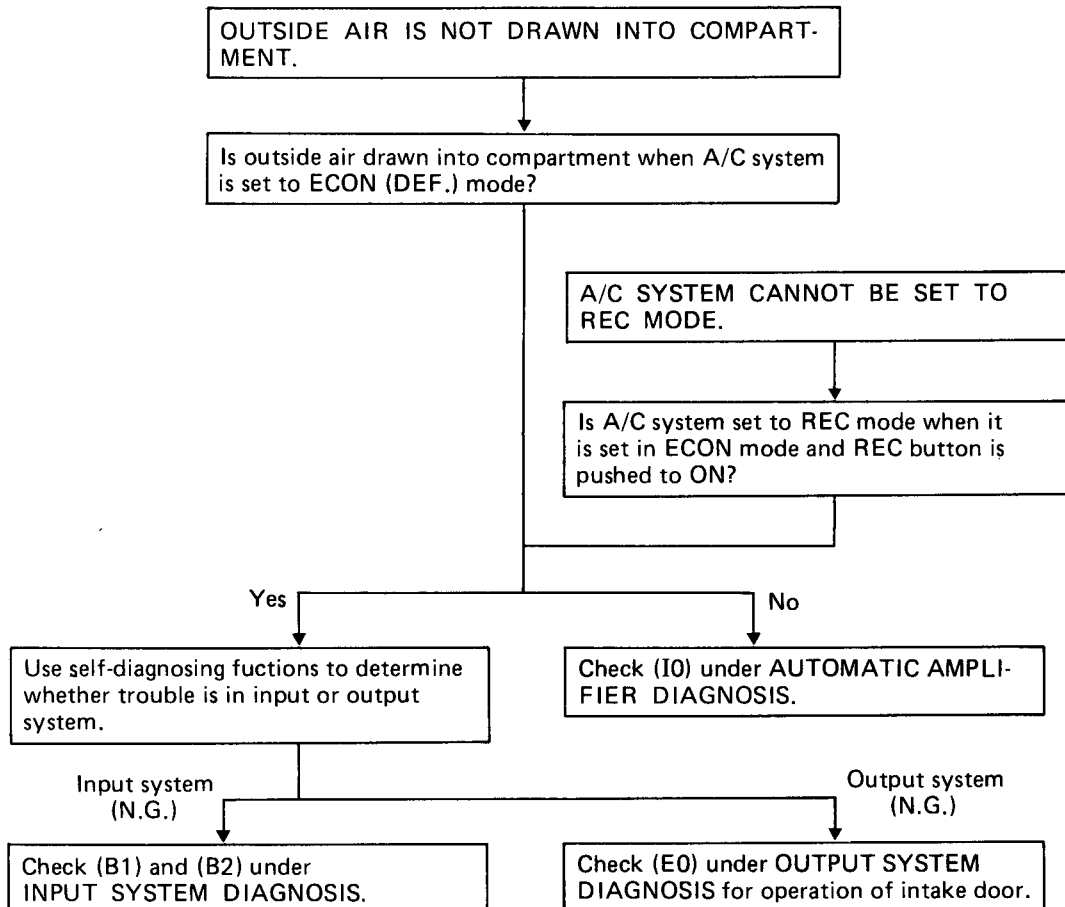
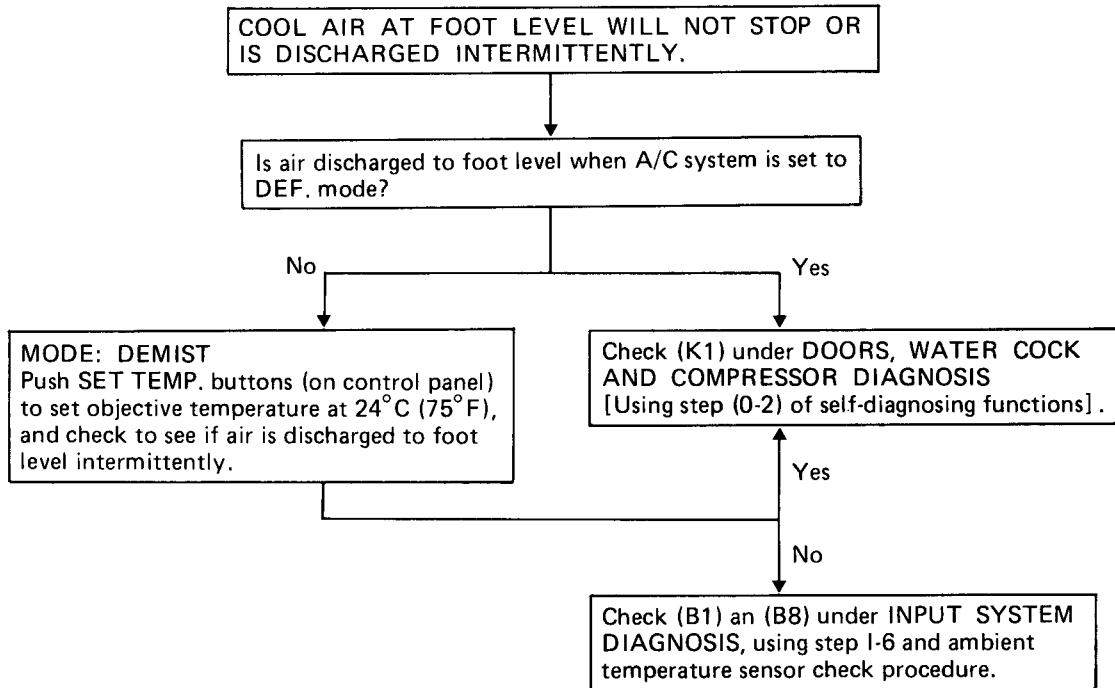

TROUBLE DIAGNOSES (Auto)

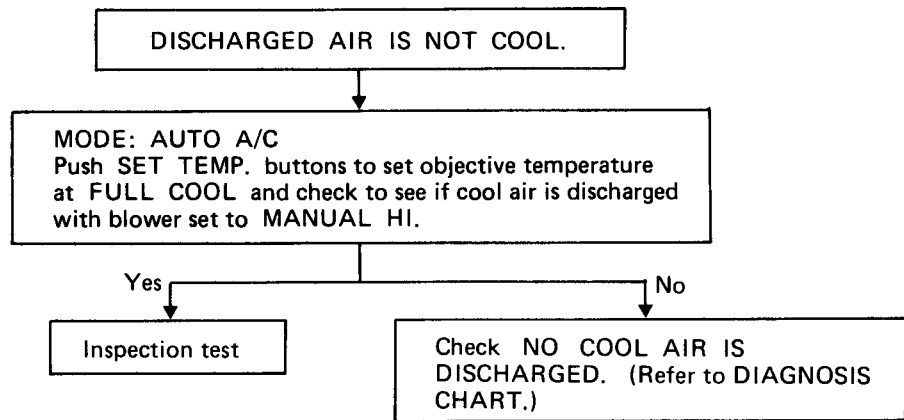
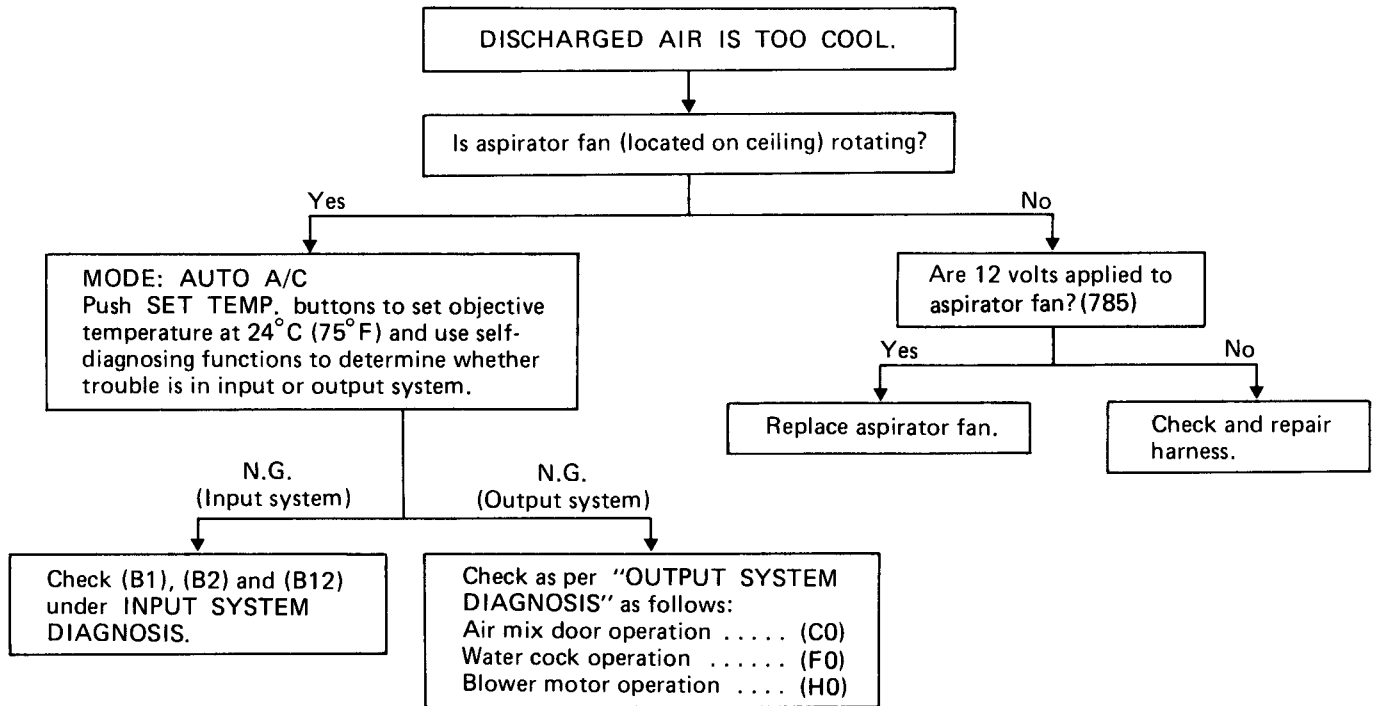

TROUBLE DIAGNOSES (Auto)

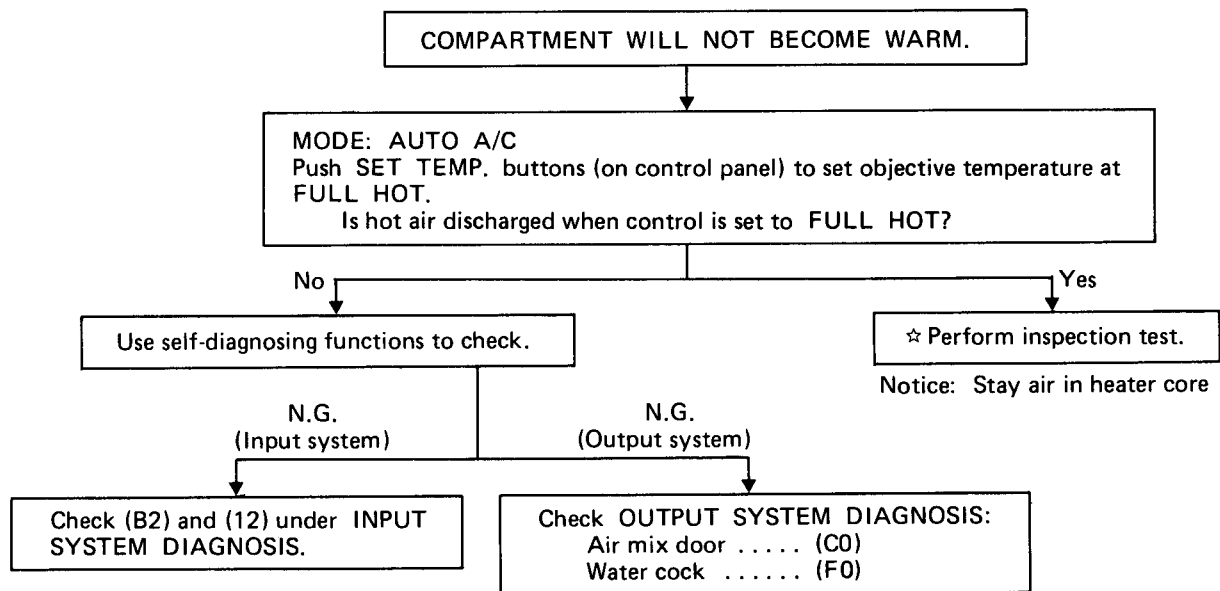
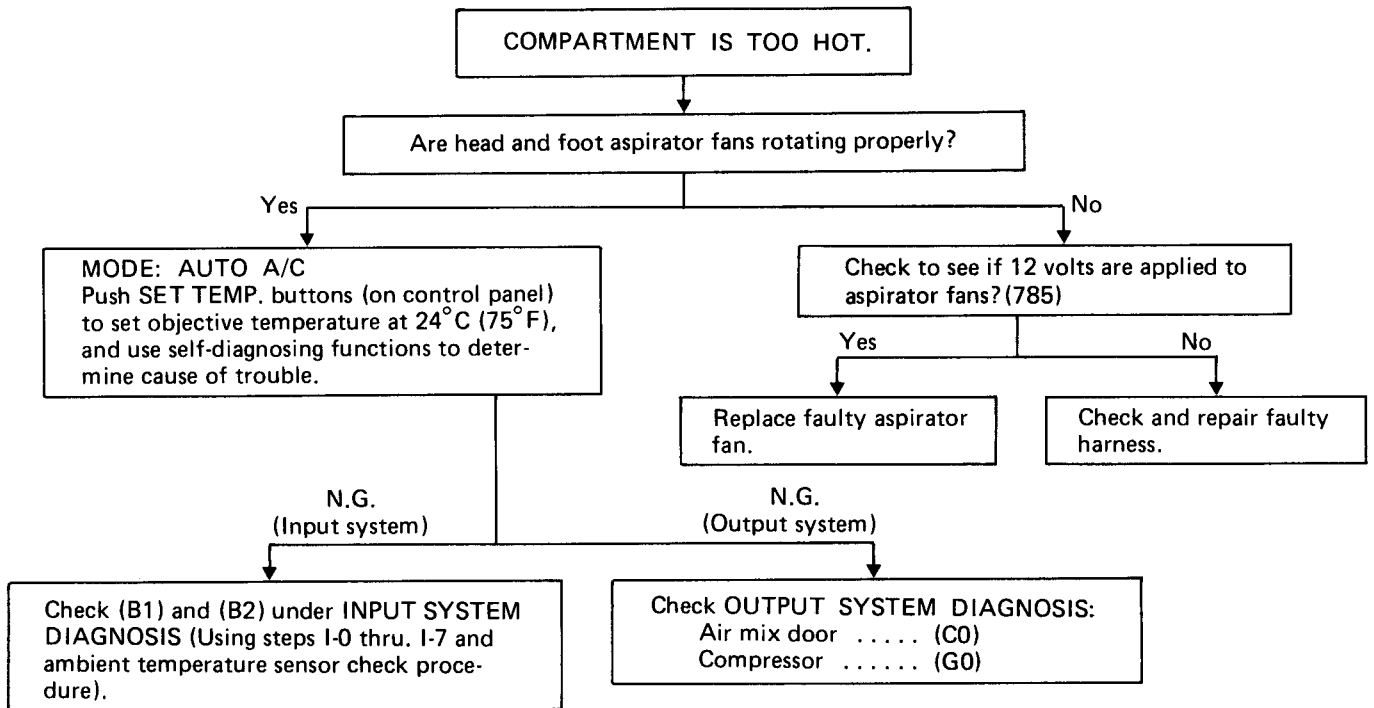

TROUBLE DIAGNOSES (Auto)

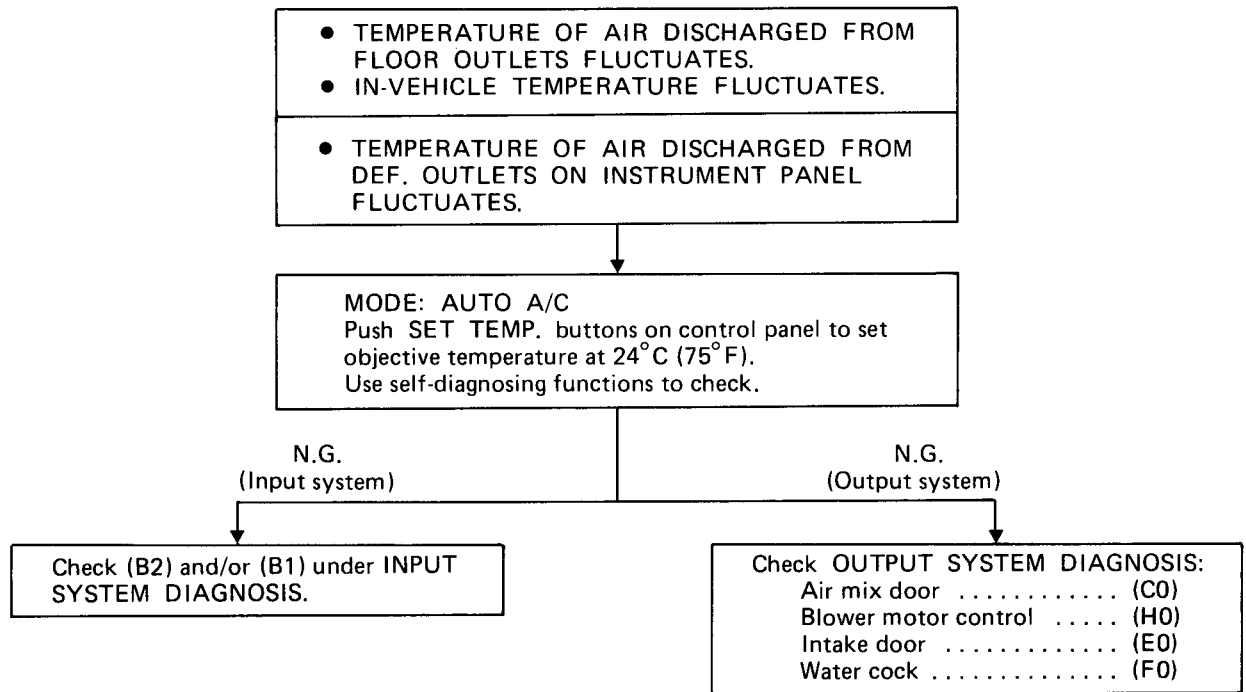

[CHECK POINTS]

Poor connection of connector harness under vibrating conditions, such as when vehicle is being driven.

TROUBLE DIAGNOSES (Auto)

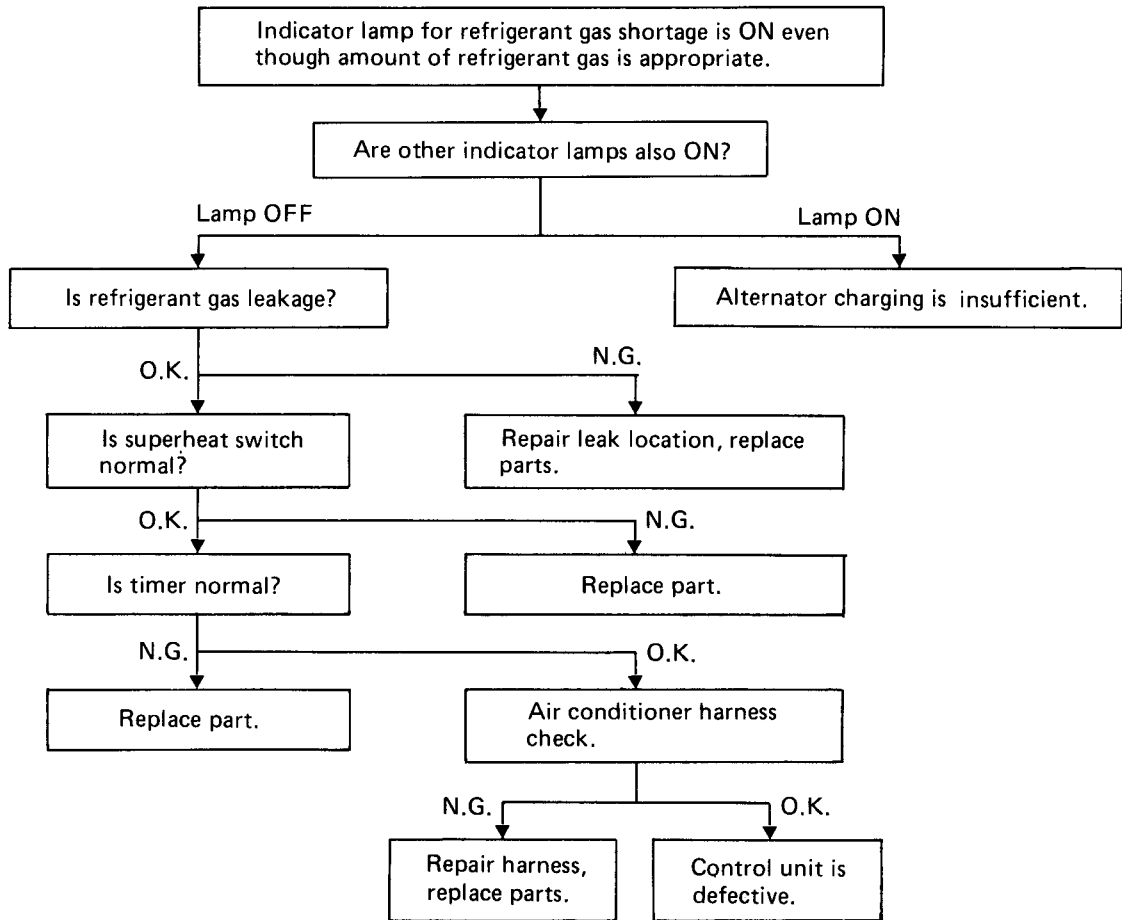

TROUBLE DIAGNOSES (Auto)

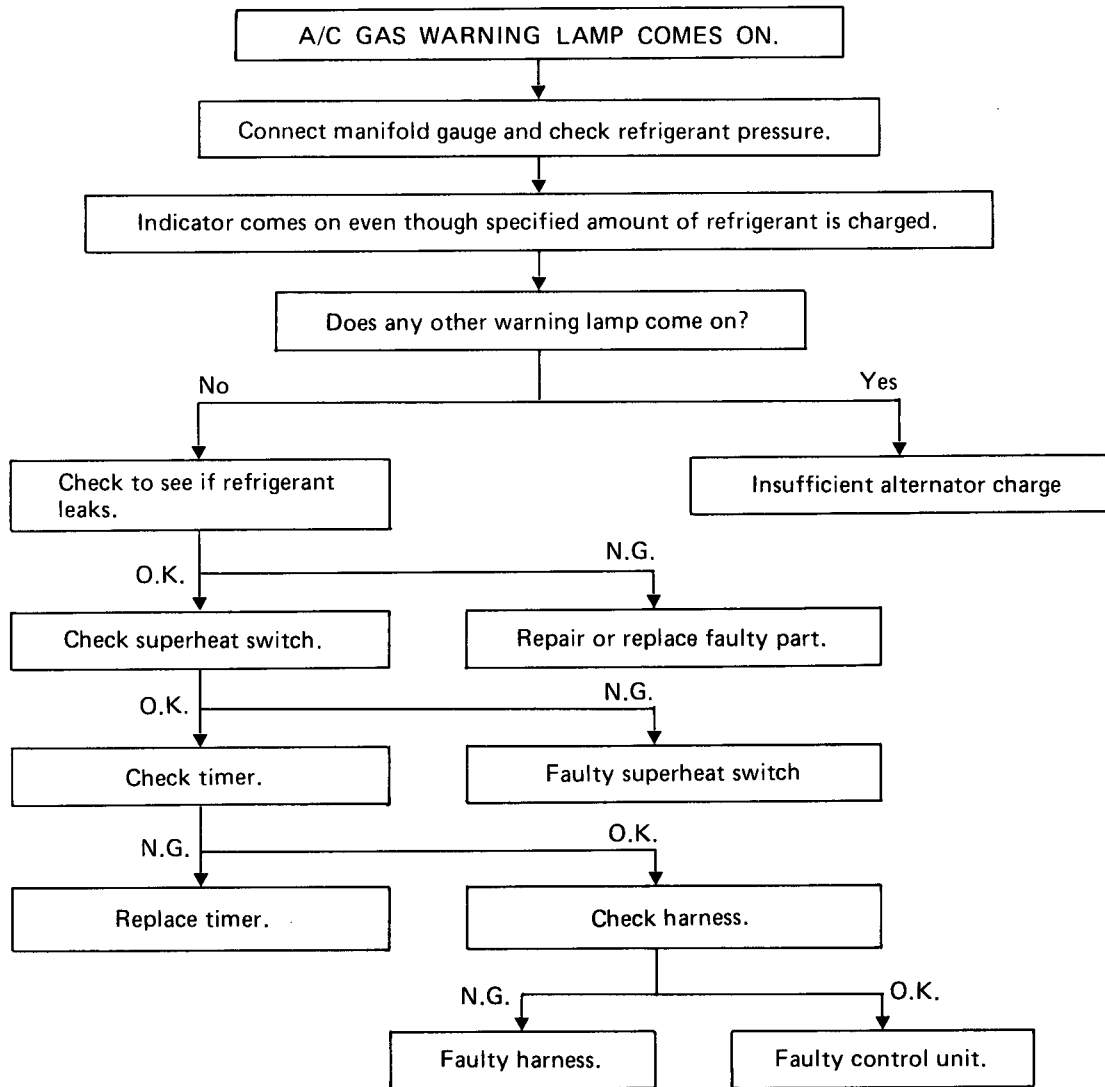

SERVICE DATA AND SPECIFICATIONS (S.D.S.)

General Specifications

COMPRESSOR

Model	MJS170
Type	Swash plate
Displacement	cm ³ (cu in)/rev. 170 (10.37)
Cylinder bore x stroke	mm (in) 40.0 x 22.6 (1.57 x 0.89)
Direction of rotation	Clockwise (viewed from drive end)
Type of driving belt	HA type (Cogged belt)

LUBRICATING OIL

Model	MJS170
Type	SUNISO 5GS
Capacity	mℓ (US fl oz, Imp fl oz)
Amount of oil in the system	150 (5.1, 5.3)
Residual oil level in the system (After oil return operation and draining oil)	120 (4.1, 4.2)

REFRIGERANT

Type	R-12
Capacity	kg (lb) 0.9 - 1.1 (2.0 - 2.4)

ENGINE IDLING SPEED

Transmission		Non-turbocharged model	Turbocharged model
When A/C is OFF			
Refer to MA section.			
When A/C is ON			
M/T	rpm	900 - 1,000	950 - 1,050
A/T	rpm	900 - 1,000 at "D" range	950 - 1,050 at "D" range

Inspection and Adjustment

COMPRESSOR

Model	MJS170
Clutch hub to pulley clearance	mm (in) 0.5 - 0.8 (0.020 - 0.031)

BELT TENSION

		Belt deflection [Applied pressure is 98 N (10 kg, 22 lb)]		
		Used	New	Limit
Air condition compressor belt	mm (in)	9.0 - 11.0 (0.354 - 0.433)	7.0 - 9.0 (0.276 - 0.354)	16 (0.63)

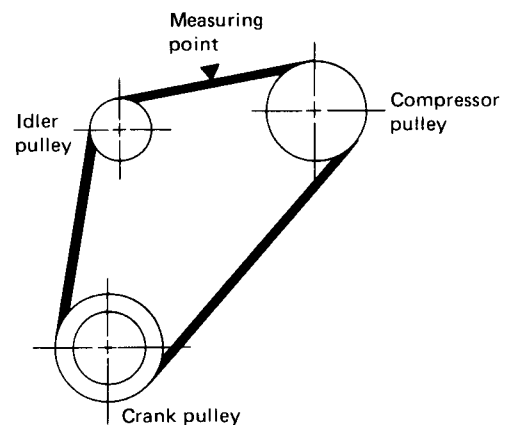

SHA252B

SERVICE DATA AND SPECIFICATIONS (S.D.S.)

Tightening Torque

COMPRESSOR INSTALLATION

	N-m	kg-m	ft-lb
Compressor bracket to cylinder block	36 - 49	3.7 - 5.0	27 - 36
Compressor to compressor bracket	36 - 49	3.7 - 5.0	27 - 36
Compressor shaft nut	19 - 21	1.9 - 2.1	14 - 15
Compressor rear cover fixing bolt	19 - 21	1.9 - 2.1	14 - 15

REFRIGERANT LINE

When connecting lines made of different material, basically use the lower tightening torque of the two.

Union type (pipe to pipe)

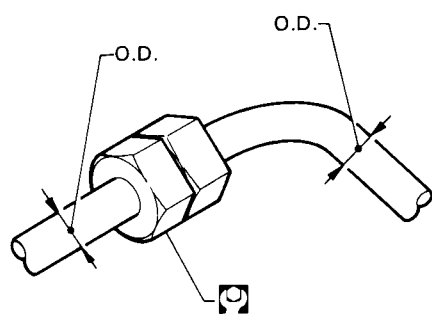

SHA669A

Pipe O.D. mm (in)	Material					
	Steel or copper			Aluminum		
	N-m	kg-m	ft-lb	N-m	kg-m	ft-lb
6 (1/4)	10 - 20	1.0 - 2.0	7 - 14	—	—	—
8 (5/16)	15 - 25	1.5 - 2.5	11 - 18	10 - 20	1.0 - 2.0	7 - 14
10 (3/8)	15 - 25	1.5 - 2.5	11 - 18	10 - 20	1.0 - 2.0	7 - 14
12 (1/2)	20 - 29	2.0 - 3.0	14 - 22	15 - 25	1.5 - 2.5	11 - 18
16 (5/8)	25 - 34	2.5 - 3.5	18 - 25	20 - 29	2.0 - 3.0	14 - 22
19 (3/4)	25 - 34	2.5 - 3.5	18 - 25	20 - 29	2.0 - 3.0	14 - 22

Union type (hose to hose)

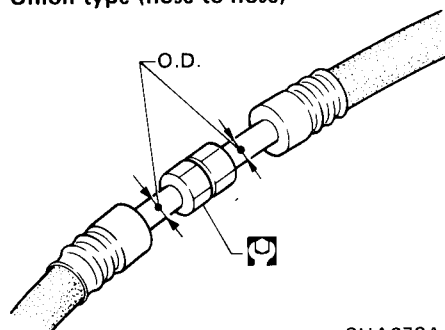

SHA670A

Pipe O.D. mm (in)	Material					
	Steel or copper			Aluminum		
	N-m	kg-m	ft-lb	N-m	kg-m	ft-lb
6 (1/4)	10 - 20	1.0 - 2.0	7 - 14	—	—	—
8 (5/16)	15 - 25	1.5 - 2.5	11 - 18	10 - 20	1.0 - 2.0	7 - 14
10 (3/8)	15 - 25	1.5 - 2.5	11 - 18	10 - 20	1.0 - 2.0	7 - 14
12 (1/2)	25 - 34	2.5 - 3.5	18 - 25	20 - 29	2.0 - 3.0	14 - 22
16 (5/8)	25 - 34	2.5 - 3.5	18 - 25	20 - 29	2.0 - 3.0	14 - 22

SERVICE DATA AND SPECIFICATIONS (S.D.S.)

Tightening Torque (Cont'd)

Union type (hose to pipe)

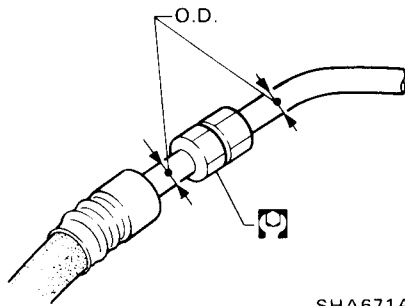

SHA671A

- Use tightening torque for flexible hose.

Plate type

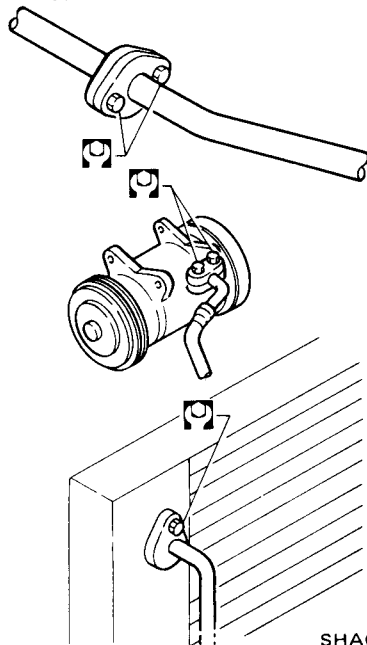



SHA672A

Grade	Nominal size	Bolt type		Tightening torque		
		Bolt diameter mm (in)	Pitch mm (in)	N·m	kg-m	ft-lb
	M6	6.0 (0.236)	1.0 (0.039)	3 - 4	0.3 - 0.4	2.2 - 2.9
4T	M8	8.0 (0.315)	1.25 (0.0492)	8 - 11	0.8 - 1.1	5.8 - 8.0
	M10	10.0 (0.394)	1.5 (0.059)	16 - 22	1.6 - 2.2	12 - 16

In case of 7T Bolt has been installed in vehicle,
Tightening torque is as same as 4T bolt.

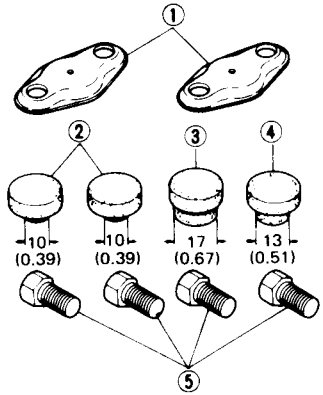
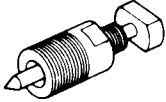
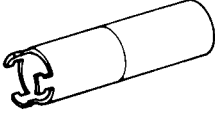
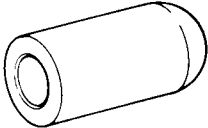
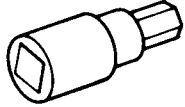
SPECIAL SERVICE TOOLS

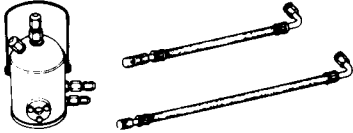
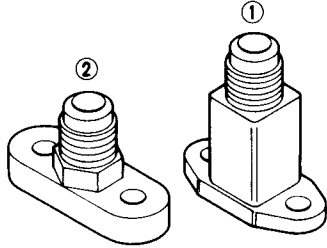
Tool number (Kent-Moore No.) Tool name	Tool	Tool number (Kent-Moore No.) Tool name	Tool
KV99412302 (J24878-1) Clutch hub wrench		KV994C4548 (J33902) Blind cover set ① KV994C4531 (-) Blind cover ② KV994C4532 (-) Gasket ③ KV994C4533 (-) Gasket (Useless) ④ KV994C4534 (-) Gasket (Useless) ⑤ KV994C4559 (-) Bolt	 <p style="text-align: center;">Unit: mm (in)</p>
KV994C5780 (J28831-A) Clutch hub puller			
KV994C1143 (J9392-01) Shaft seal remover and installer			
KV994C5784 (J33212) Shaft seal pilot			
KV99412330 (-) Allen socket			
KV994C5785 (-) Cylinder head remover			
KV994A9690 (-) Oil separator kit			
KV992C5079 (-) ① KV992C5081 (-) Adapter connector A ② KV992C5082 (-) Adapter connector B			
KV994C1552 (-) Charge nozzle	