

MAINTENANCE

SECTION MA

MA

CONTENTS

PERIODIC MAINTENANCE	MA- 2
GENERAL MAINTENANCE	MA- 4
LUBRICATION CHART	MA- 7
ENGINE MAINTENANCE	MA- 8
CHASSIS AND BODY MAINTENANCE	MA-22
SERVICE DATA AND SPECIFICATIONS (S.D.S.)	MA-41
SPECIAL SERVICE TOOLS	MA-43

PERIODIC MAINTENANCE

The following charts show the normal maintenance schedule. Under severe driving conditions, additional or more frequent maintenance will be required. Refer to "Maintenance under severe driving conditions".

The periodic maintenance schedule is repeated beyond the last mileage and period shown by returning to the first 15,000 miles (24,000 km) or 12 months.

EMISSION CONTROL SYSTEM MAINTENANCE

MAINTENANCE OPERATION		MAINTENANCE INTERVAL							Reference page	
Periodic maintenance should be performed at number of miles, kilometers or months, whichever comes first.		Miles x 1,000	5	7.5	15	30	45	60		
		(Kilometers x 1,000)	(8)	(12)	(24)	(48)	(72)	(96)		
		Months	6	6	12	24	36	48		
Drive belts						I		I	MA-8	
Air cleaner filter						Replace every 30,000 miles (48,000 km).			MA-8	
Vapor lines						I*		I*	MA-8	
Fuel lines (hoses, piping, connections, etc.)						I*		I*	MA-9	
Fuel filter						See NOTE (1)*			MA-9	
Engine coolant						R		R	MA-10, 11	
Engine oil	Except turbocharged engine		R			Then replace every 7,500 miles (12,000 km) or 6 months.			MA-12	
	Turbocharged engine		R			Then replace every 5,000 miles (8,000 km) or 6 months.			MA-12	
Engine oil filter	Except turbocharged engine		R			Then replace every second oil change.			MA-12	
	Turbocharged engine		R							
Spark plugs						Replace every 30,000 miles (48,000 km).			MA-13	
Ignition wires						Inspect every 2 years*			MA-14	
Idle rpm (Except turbocharged engine)						I*	I*	I*	I*	MA-15
Exhaust gas sensor						Inspect every 30,000 miles (48,000 km).			MA-16, 17	
Timing belt						Replace every 60,000 miles (96,000 km).			MA-18	

CHASSIS AND BODY MAINTENANCE

MAINTENANCE OPERATION		MAINTENANCE INTERVAL							Reference page
Periodic maintenance should be performed at number of miles, kilometers or months, whichever comes first.		Miles x 1,000	15	30	45	60			
		(Kilometers x 1,000)	(24)	(48)	(72)	(96)			
		Months	12	24	36	48			
Brake lines & hoses			I	I	I	I			MA-31
Brake pads & discs						Inspect every 15,000 miles (24,000 km).			MA-32
Manual and automatic transmission & differential gear oil						Inspect every 15,000 miles (24,000 km).			MA-23, 24, 25
Power steering lines & hoses			I	I	I	I			MA-35
Steering gear & linkage, and axle & suspension parts			I	I	I	I			MA-26, 27, 28, 39
Steering linkage ball joints & front suspension ball joints							I		MA-26
Locks, hinges & hood latch			L	L	L	L			MA-40
Front wheel bearing grease						I	I		MA-27
Exhaust system			I	I	I	I			MA-22
Seat belts, buckles, retractors, anchors & adjuster			I	I	I	I			MA-40

NOTE: (1) If vehicle is operated under extremely adverse weather conditions or in areas where ambient temperatures are either extremely low or extremely high, the filters might become clogged. In such an event, replace them immediately.

(2) Maintenance items and intervals with "*" are recommended by NISSAN. Other maintenance items and intervals are required.

Abbreviations: A = Adjust
R = Replace
L = Lubricate
I = Inspect. Correct or replace if necessary.

PERIODIC MAINTENANCE

MAINTENANCE UNDER SEVERE DRIVING CONDITIONS

The maintenance intervals shown on the preceding pages are for normal operating conditions. If the vehicle is operated under severe driving conditions as shown below, more frequent maintenance is required to be performed on the following items as shown in the table.

Severe driving conditions

- A — Repeated short distance driving
- B — Extensive idling
- C — Driving in dusty conditions
- D — Driving in extremely low or high ambient temperatures
- E — Towing a trailer
- F — Driving in areas using road salt or other corrosive materials
- G — Driving on rough and/or muddy roads

Driving condition	Maintenance item	Maintenance operation	Maintenance interval	Reference page
. . C	Air cleaner filter	R	More frequently	MA-8
A B C . E	Engine oil & oil filter	R	Every 3,000 miles (5,000 km) or 3 months	MA-12
A . C . E F G . .	Brake pads & discs	I	Every 7,500 miles (12,000 km)	MA-32
. . . . E . G . .	Manual and automatic transmission & differential gear oil	R	Every 30,000 miles (48,000 km) or 24 months	MA-23, 24, 25
. G . . .	Steering gear & linkage, and axle & suspension parts	I	Every 7,500 miles (12,000 km) or 6 months	MA-26, 27, 28, 39
. . C D . F G . .	Steering linkage ball joints & front suspension ball joints	I	Every 7,500 miles (12,000 km) or 6 months	MA-26
. F . . .	Locks, hinges & hood latch	L	Every 7,500 miles (12,000 km) or 6 months	MA-40
A . . . E F G . .	Exhaust system	I	Every 7,500 miles (12,000 km) or 6 months	MA-22

Maintenance operations: I = Inspect. Correct or replace if necessary R = Replace
L = Lubricate

GENERAL MAINTENANCE

General maintenance includes those items which should be checked during the normal day-to-day operation of the vehicle. They are essential if the vehicle is to continue operating properly. The owners can perform the checks and inspections themselves or they can have their NISSAN/DATSUN dealers do them for a nominal charge.

Item	Reference item in MA section
OUTSIDE THE VEHICLE	
Tires Check the pressure with a gauge periodically when at a service station, including the spare, and adjust to the specified pressure if necessary. Check carefully for damage, cuts or excessive wear.	● CHECKING TIRE CONDITION
Wheel nuts When checking the tires, make sure no nuts are missing, and check for any loose nuts. Tighten if necessary.	● TIRE REPLACEMENT Wheel nut.
Tire rotation Tires should be rotated every 24,000 km (15,000 miles).	● TIRE ROTATION
Wheel alignment and balance If the vehicle should pull to either side while driving on a straight and level road, or if you detect uneven or abnormal tire wear, there may be a need for wheel alignment. If the steering wheel or seat vibrates at normal highway speeds, wheel balancing may be needed.	● CHECKING TIRE CONDITION Abnormal tire wear ● CHECKING WHEEL ALIGNMENT ● WHEEL INSPECTION
Windshield glass Check for abrasions or scratches.	—
Windshield wiper blades Check for cracks or wear if they do not wipe properly.	—
Doors and engine hood Check that all doors and the engine hood operate smoothly as well as the trunk lid and back hatch. Also, ensure that all latches lock securely. Lubricate if necessary. Make sure that the secondary latch keeps the hood from opening when the primary latch is released.	● LUBRICATING LOCKS, HINGES AND HOOD LATCH
INSIDE THE VEHICLE	
The maintenance items listed here should be checked on a regular basis, such as when performing periodic maintenance, cleaning the vehicle, etc.	
Lights Make sure that the headlights, stop lights, tail lights, turn signal lights, and other lights are all operating properly and installed securely. Also check headlight aim.	—
Warning lights and buzzers/chimes Make sure that all warning lights and buzzers/chimes are operating properly.	—
Horn Make sure it operates properly.	—
Windshield wiper and washer Check that the wipers and washer operate properly and that the wipers do not streak.	—

GENERAL MAINTENANCE

Item	Reference item in MA section
Windshield defroster Check that the air comes out of the defroster outlets properly and in sufficient quantity when operating the heater or air conditioner.	—
Rear view mirror Make sure that it is secure.	—
Sun visors Make sure that they can be moved freely and are secure.	—
Steering wheel Check that it has the specified free play. Be sure to check for changes in the steering condition, such as excessive free play, hard steering or strange noises.	Specification Free play: Less than 35 mm (1.38 in)
Seats Check seat position controls such as seat adjusters, seatback recliner, etc. to ensure they operate smoothly and that all latches lock securely in every position. Check that the head restraints move up and down smoothly and that the locks (if so equipped) hold securely in all latched positions. Check that the latches lock securely for folding-down rear seatbacks.	—
Seat belts Check that all parts of the seat belt system e.g. buckles, anchors and retractors operate properly and smoothly. Check the belt webbing for cuts, fraying, wear or damage.	<ul style="list-style-type: none"> ● INSPECTING SEAT BELTS, BUCKLES, ANCHORS, RETRACTORS AND ADJUSTER
Accelerator pedal Check the pedal for smooth operation and make sure the pedal does not catch or require uneven effort.	—
Clutch pedal Make sure the pedal operates smoothly and check that it has the proper free travel.	<ul style="list-style-type: none"> ● ADJUSTING CLUTCH PEDAL HEIGHT AND FREE PLAY
Brakes Check that the brake does not pull the vehicle to one side when applied.	—
Brake pedal Check the pedal for smooth operation and make sure it has the proper distance under it when depressed fully. Check the brake booster function.	<ul style="list-style-type: none"> ● CHECKING BRAKE PEDAL DEPRESSED HEIGHT ● CHECKING BRAKE BOOSTER FUNCTION
Parking brake Check that the lever has the proper travel and confirm that your vehicle is held securely on a fairly steep hill with only the parking brake applied.	<ul style="list-style-type: none"> ● CHECKING PARKING BRAKE
Automatic transmission "Park" mechanism Check that the lock release button on the selector lever operates properly and smoothly. On a fairly steep hill check that your vehicle is held securely with the selector lever in the "P" position without applying any brakes.	—
UNDER THE HOOD AND VEHICLE	
The maintenance items listed here should be checked periodically e.g. each time you check the engine oil or refuel.	

GENERAL MAINTENANCE

Item	Reference item in MA section
Windshield washer fluid Check that there is adequate fluid in the tank.	—
Engine coolant level Check the coolant level when the engine is cold.	—
Radiator and hoses Check the front of the radiator and clean off any dirt, insects, leaves, etc., that may have accumulated. Make sure the hoses have no cracks, deformation, rot or loose connections.	—
Brake and clutch fluid levels Make sure that the brake and clutch fluid levels are between the "MAX" and "MIN" lines on the reservoir.	<ul style="list-style-type: none"> ● CHECKING CLUTCH FLUID LEVEL ● CHECKING BRAKE FLUID LEVEL AND LEAKS
Engine drive belts Make sure that no belt is frayed, worn, cracked or oily.	<ul style="list-style-type: none"> ● CHECKING DRIVE BELT
Engine oil level Check the level on the dipstick after parking the vehicle on a level spot and turning off the engine.	<ul style="list-style-type: none"> ● CHANGING ENGINE OIL AND OIL FILTER
Power steering fluid level Check the level when the fluid is cold and the engine is turned off.	<ul style="list-style-type: none"> ● CHECKING POWER STEERING FLUID LEVEL
Automatic transmission fluid level Check the level on the dipstick after putting the selector level in "P" with the engine idling.	<ul style="list-style-type: none"> ● CHECKING AUTOMATIC TRANSMISSION FLUID LEVEL
Exhaust system Make sure there are no loose supports, cracks or holes. If the sound of the exhaust seems unusual or there is a smell of exhaust fumes, immediately locate the trouble and correct it.	<ul style="list-style-type: none"> ● INSPECTING EXHAUST SYSTEM
Underbody The underbody is frequently exposed to corrosive substances such as those used on icy roads or to control dust. It is very important to remove these substances, otherwise rust will form on the floor pan, frame, fuel lines and around the exhaust system. At the end of winter, the underbody should be thoroughly flushed with plain water, being careful to clean those areas where mud and dirt can easily accumulate.	—
Fluid leaks Check under the vehicle for fuel, oil, water or other fluid leaks after the vehicle has been parked for a while. Water dripping from the air conditioner after use is normal. If you should notice any leaks or gasoline fumes are evident, check for the cause and correct it immediately.	<ul style="list-style-type: none"> ● CHECKING CLUTCH FLUID LEAKS ● INSPECTING MANUAL TRANSMISSION OIL ● INSPECTING AUTOMATIC TRANSMISSION FLUID ● INSPECTING DIFFERENTIAL GEAR OIL ● INSPECTING BRAKE LINES & HOSES ● CHECKING POWER STEERING LINE & HOSES

LUBRICATION CHART

	CHANGE
	LUBRICATE
	CHECK

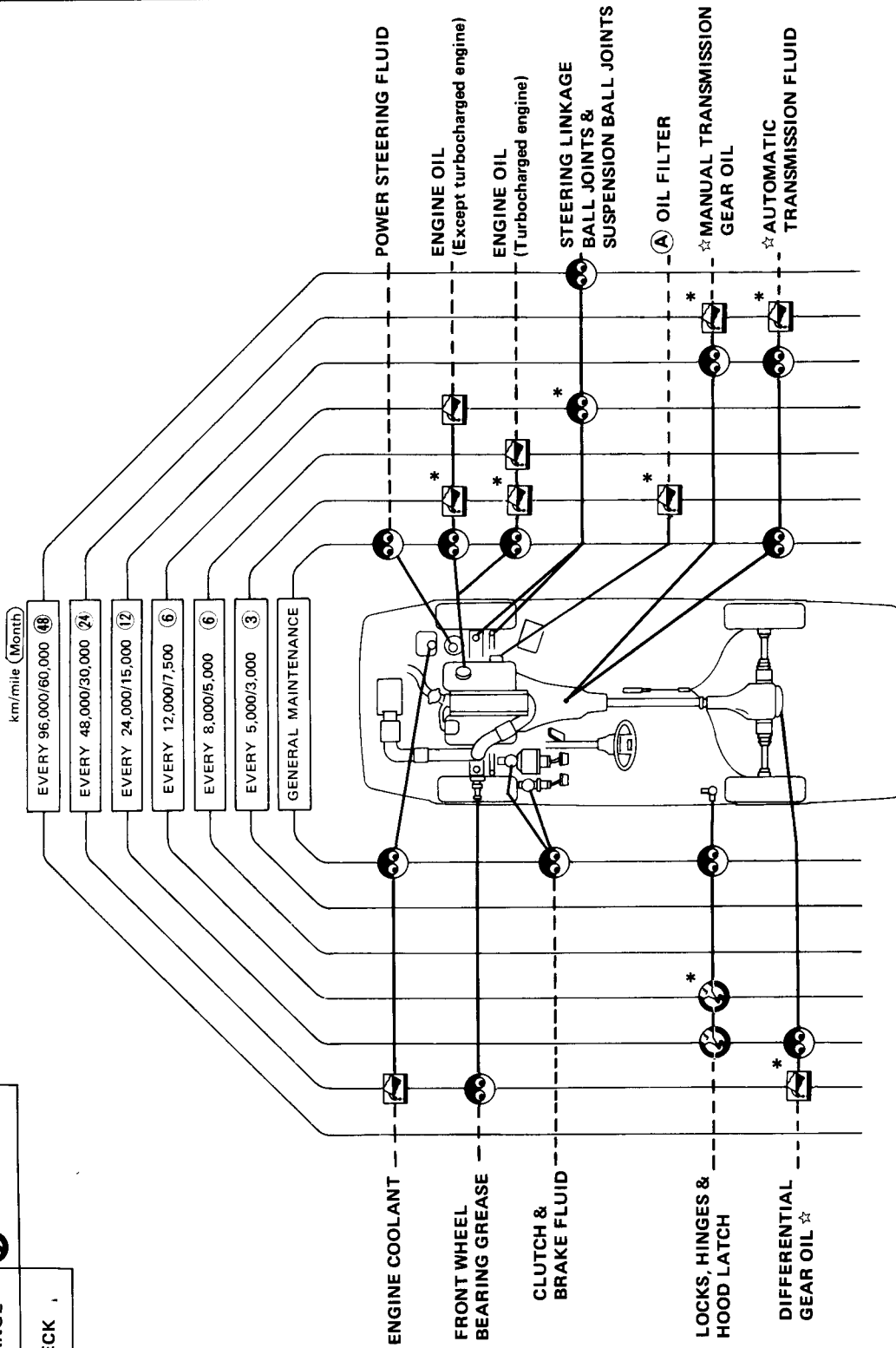

☆ : At the specified mileage (km/mile) only
 * : Maintenance under severe driving conditions

(A) Replace at the first oil change and then every second oil change.

ENGINE MAINTENANCE

Checking Drive Belts

1. Inspect for cracks, fraying, wear or oil adhesion. Replace if necessary.

The belts should not touch the bottom of the pulley groove.

2. Check drive belt deflections by pushing on the belt middle between pulleys.

Adjust if belt deflections exceed the limit.

• VG30E engine (without turbocharger)

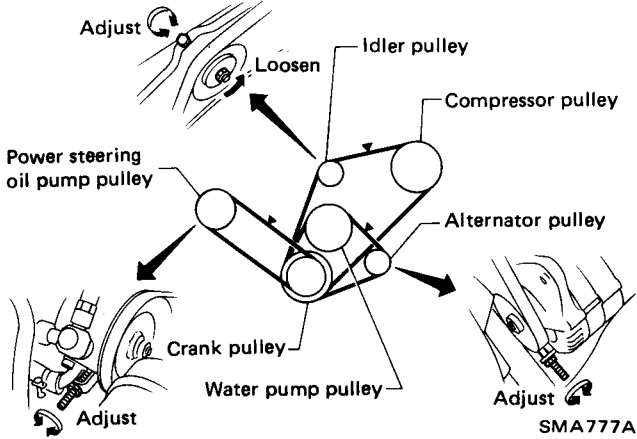

• VG30ET engine (with turbocharger)

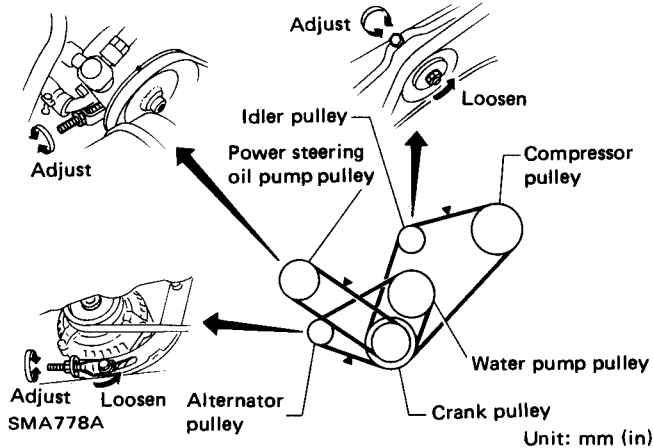

		Used belt deflection		Set deflection of new belt
		Limit	Adjusted deflection	
Alternator	VG30E	12 (0.47)	6 - 8 (0.24 - 0.31)	5 - 7 (0.20 - 0.28)
	VG30ET	11 (0.43)	6 - 9 (0.24 - 0.35)	5 - 8 (0.20 - 0.31)
Air conditioner compressor		16 (0.63)	9 - 11 (0.35 - 0.43)	7 - 9 (0.28 - 0.35)
Power steering oil pump		21 (0.83)	13 - 16 (0.51 - 0.63)	10 - 13 (0.39 - 0.51)
Applied pushing force		98 N (10 kg, 22 lb)		

Replacing Air Cleaner Filter

The viscous paper type air cleaner filter does not require any cleaning operation between renewals.

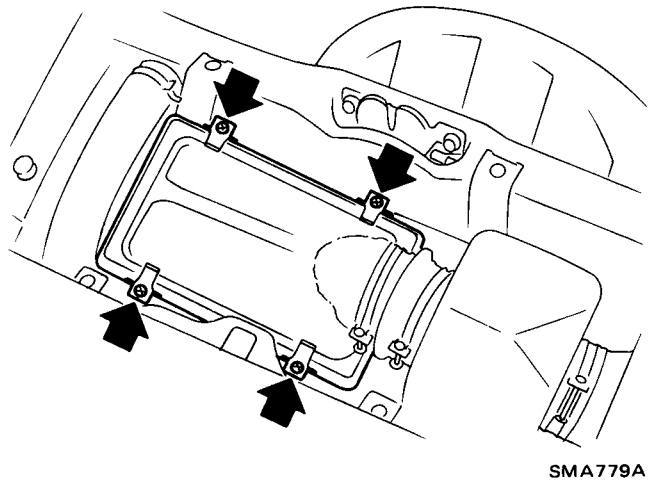

Checking Vapor Lines

1. Visually inspect vapor lines for proper attachment, cracks, damage, loose connections, chafing and deterioration.
2. Check fuel tank vacuum relief valve for clogging, sticking, etc.

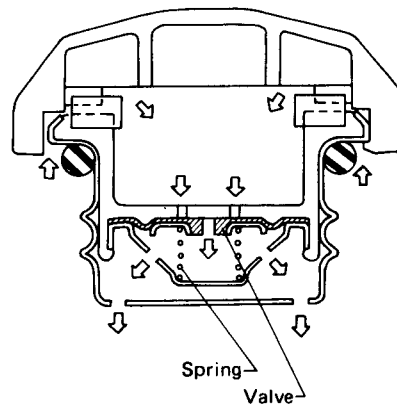

SEC308A

ENGINE MAINTENANCE

Checking Fuel System

Check fuel lines and tank for proper attachment, leaks, cracks, damage, loose connections, chafing and deterioration.

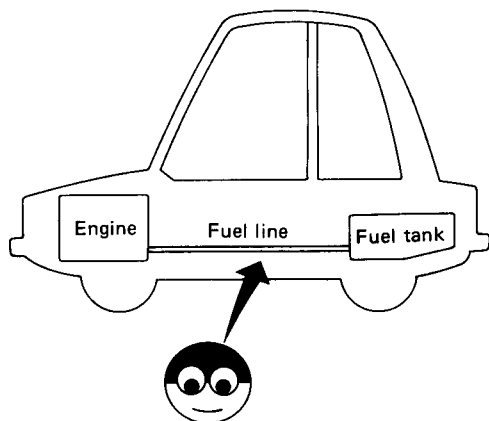

SMA803A

CAUTION:

- Do not reuse fuel hose clamp after loosening.
- Tighten high pressure rubber hose clamp so that clamp end is 3 mm (0.12 in) from hose end or screw position (wider than other portions of clamp) is flush with hose end.
- When tightening hose clamp, ensure that screw does not come into contact with adjacent parts.

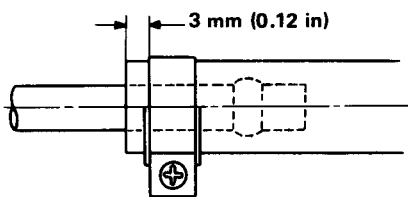

 Fuel hose clamps
1.0 - 1.5 N·m
(0.10 - 0.15 kg·m,
0.7 - 1.1 ft·lb)

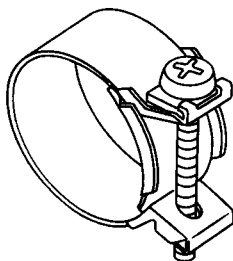

SMA804A

Replacing Fuel Filter

Before removing fuel filter, release fuel pressure from fuel line to eliminate danger.

- Start engine.
- Remove fuse for fuel pump with engine running.
- After engine stalls, crank engine two or three times to make sure that pressure is released.
- Turn ignition switch off and connect fuel pump fuse.
- Loosen fuel hose clamps.

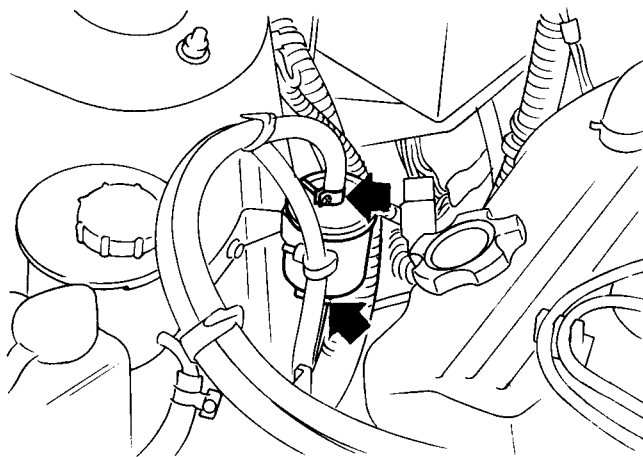

SMA780A

- Replace fuel filter.
 - Do not reuse fuel hose clamps.
 - Be careful not to spill fuel over engine compartment. Place a rag to absorb fuel.
 - Use high pressure type fuel filter. Do not use a synthetic resinous fuel filter.

ENGINE MAINTENANCE

Changing Engine Coolant

WARNING:

To avoid the danger of being scalded, never attempt to change the coolant when the engine is hot.

1. Before draining engine coolant:

- 1) Except auto air conditioner equipped models
Slide temperature control lever to "HOT" position.

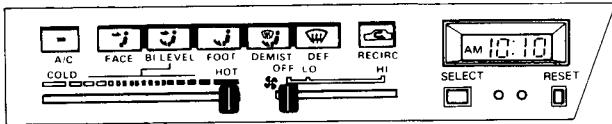

SMA781A

- 2) Auto air conditioner equipped models
Turn ignition switch "ON" and set temperature at maximum.
Then turn ignition switch "OFF".

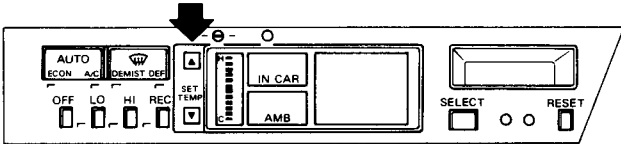

SMA782A

2. Open radiator cap and drain cock to drain engine coolant.

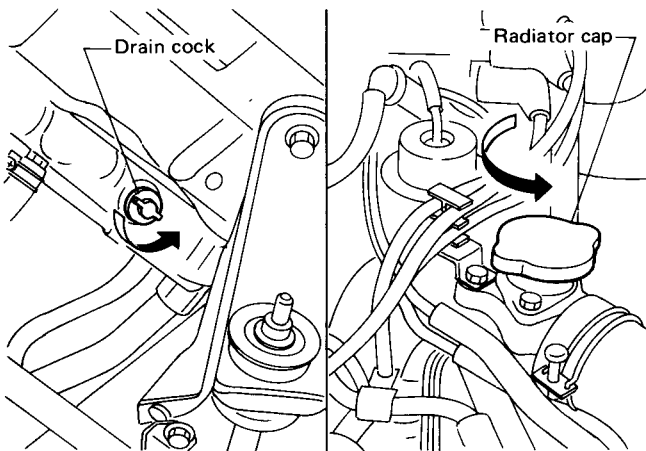

SMA783A

3. Open drain plugs on the left side of cylinder block to drain coolant from cylinder block.

Drain plug

22 - 27 N·m

(2.2 - 2.8 kg-m, 16 - 20 ft-lb)

4. Close drain plugs and drain cock securely.
Then, fill radiator with water and warm up engine.
5. Stop engine and wait until it cools down.
6. Repeat procedure from step 2 through step 5 two or three times.
7. Drain water and fill radiator and engine with new coolant up to filler opening. Follow instructions attached to anti-freeze container for mixing ratio of anti-freeze to water.

- Slowly pour coolant through coolant filler neck to allow air in system to escape.

- If the hoses connecting engine and heater have been disconnected to dismount heater core unit and engine, always perform the following work before filling with engine coolant.

- (1) Set the heater temperature lever or button to "Full Hot" position.

- (2) Disconnect the upper hose from water cock, and fill the heater core unit with 500 ml (16.9 US fl oz, 17.6 Imp fl oz) or more of coolant.

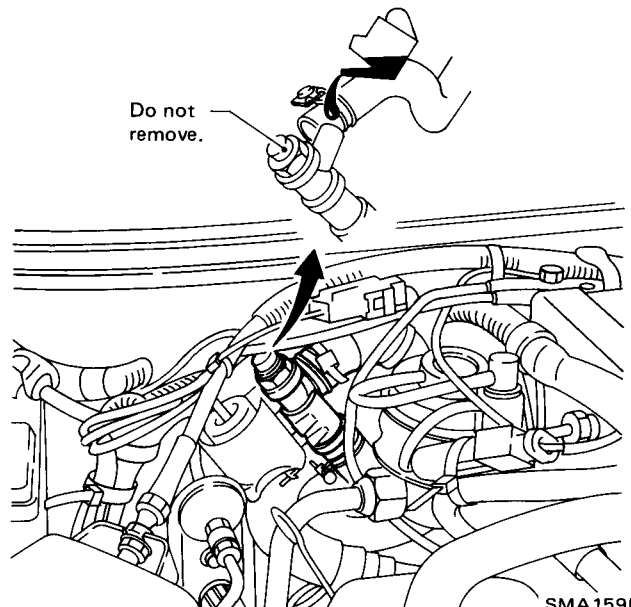

SMA159B

ENGINE MAINTENANCE

Changing Engine Coolant (Cont'd)

- (3) Connect the hoses.
8. Fill reservoir tank up to "MAX" level. Then close radiator cap.
9. Run the engine at approximately 2,000 rpm for about one minute.
10. Stop the engine and after it cools down, refill the radiator and engine with coolant up to the filler opening. Fill the reservoir tank with coolant up to "MAX" level.

Coolant capacity: (Without reservoir tank)

VG30E engine

10.5 ℓ (11-1/8 US qt, 9-1/4 Imp qt)

VG30ET engine

11.0 ℓ (11-5/8 US qt, 9-5/8 Imp qt)

Reservoir tank:

0.8 ℓ (7/8 US qt, 3/4 Imp qt)

ENGINE MAINTENANCE

Changing Engine Oil and Oil Filter

1. Warm up engine, and check for oil leakage from engine components.
2. Change engine oil and oil filter.

Oil capacity (Refill):

With oil filter

4.0 ℓ (4-1/4 US qt, 3-1/2 Imp qt)

Without oil filter

3.6 ℓ (3-7/8 US qt, 3-1/8 Imp qt)

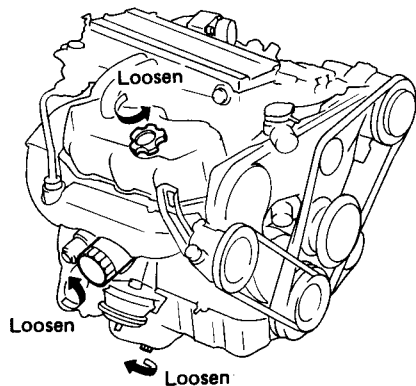

 29 - 39 N·m
(3.0 - 4.0 kg·m, 22 - 29 ft·lb)

SMA785A

- a. When removing and installing oil filter, use a tool.

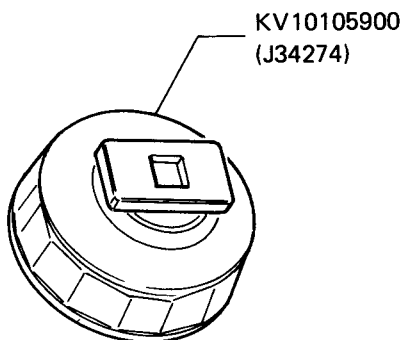

SMA167B

- b. Be careful not to burn yourself as engine oil is hot.
- c. Be sure to clean drain plug and install with washer.

- d. Before installing new oil filter, wipe oil filter mounting surface on cylinder block, and smear a little engine oil on rubber seal of oil filter.

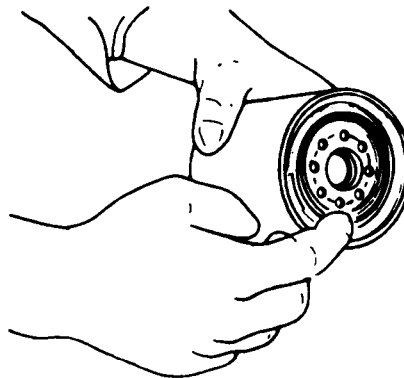

SMA010

- e. When installing oil filter, screw it in until a slight resistance is felt, then tighten an additional 2/3 turn.
- f. Use recommended engine oil.

3. Start engine. Check area around drain plug and oil filter for any sign of oil leakage. Run engine for a few minutes, then turn it off. After several minutes, check oil level.

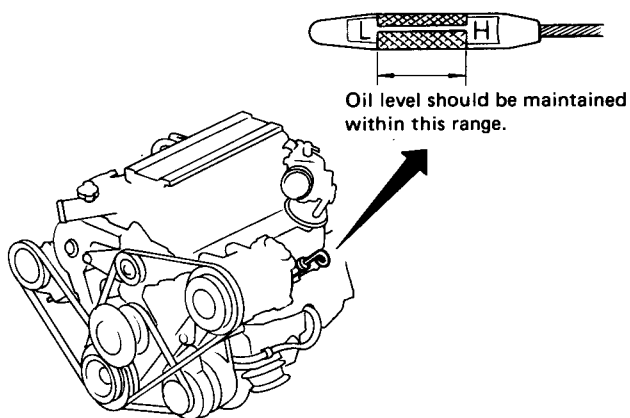

Oil level should be maintained within this range.

SMA786A

ENGINE MAINTENANCE

Checking and Replacing Spark Plugs

1. Disconnect ignition wires from spark plugs by pulling on the boot. Do not pull on the wires.

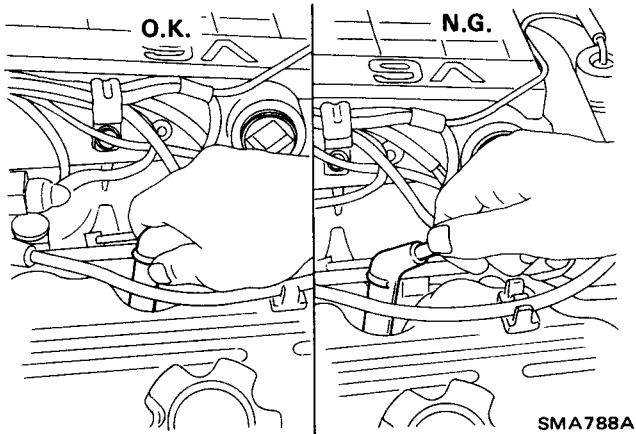

2. Remove spark plugs with a suitable plug wrench as shown below.



Wrench with a magnet to hold spark plug

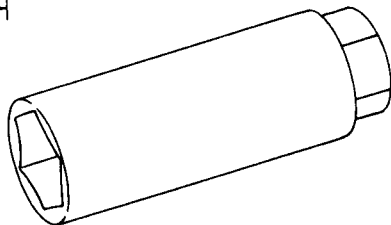

SEM294A

3. Inspect insulator for cracks or chips, gasket for damage or deterioration.

4. Check spark plug gap.

Gap:
1.0 - 1.1 mm (0.039 - 0.043 in)

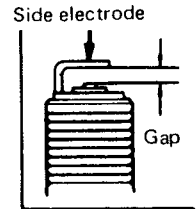
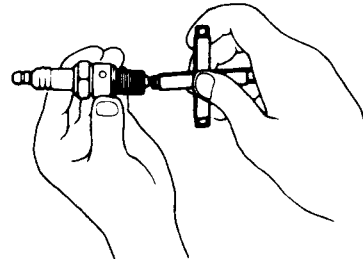

SMA476

	VG30E	VG30ET
Standard type	BCPR6ES-11	BCPR6E-11
Hot type	BCPR5ES-11	BCPR5E-11
Cold type	BCPR7ES-11	BCPR7E-11

5. Install spark plugs. Reconnect ignition wires according to Nos. indicated on them.

 : Spark plug
20 - 29 N·m
(2.0 - 3.0 kg·m, 14 - 22 ft·lb)

ENGINE MAINTENANCE

Checking Ignition Wires

1. Check the high tension wires for cracks, damage, burned terminals and proper fit.
2. Measure the resistance of the high tension wires, by shaking it and checking for intermittent breaks.

Resistance:
Less than 30,000 ohms

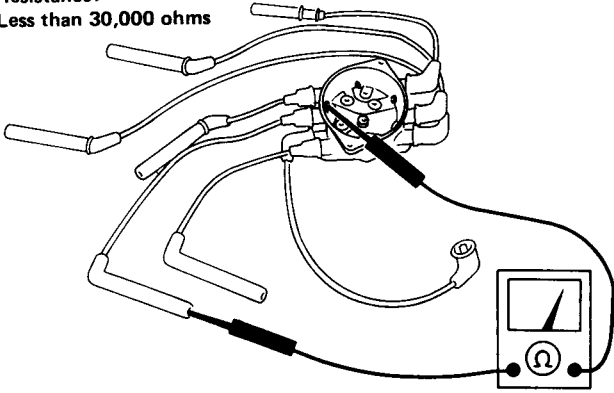

SMA789A

ENGINE MAINTENANCE

Checking Idle Speed (VG30E engine)

Preparation

- Engage parking brake and lock both front and rear wheels with wheel chocks.
- Turn off air conditioner and headlamps.
- Keep front wheels straight ahead.

WARNING:

- Depress brake pedal while accelerating the engine to prevent forward surge of vehicle.
- Inspection should be carried out while shift lever is in "D" position on automatic transmission equipped models.

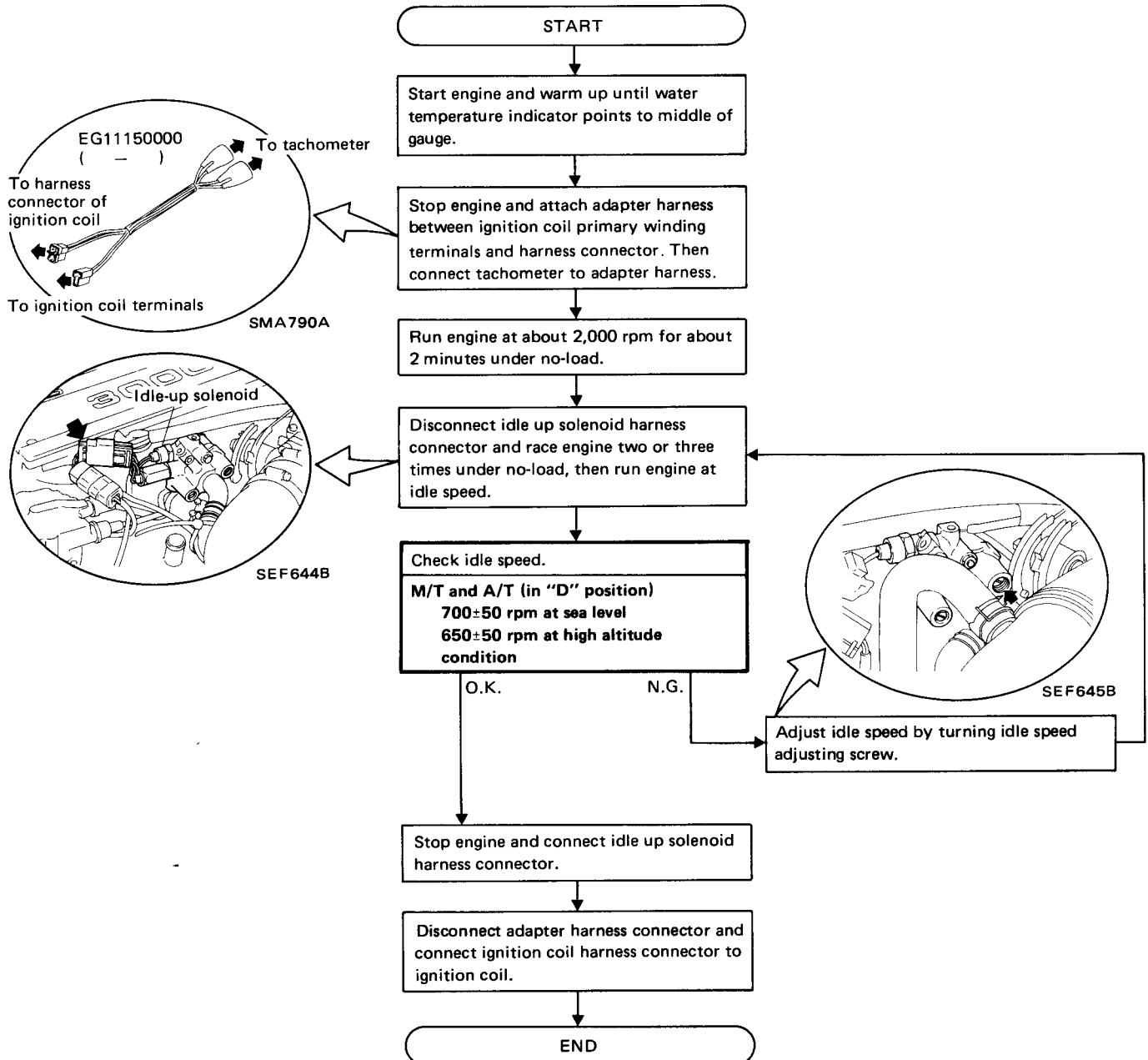

ENGINE MAINTENANCE

Checking Exhaust Gas Sensor

Checking procedure

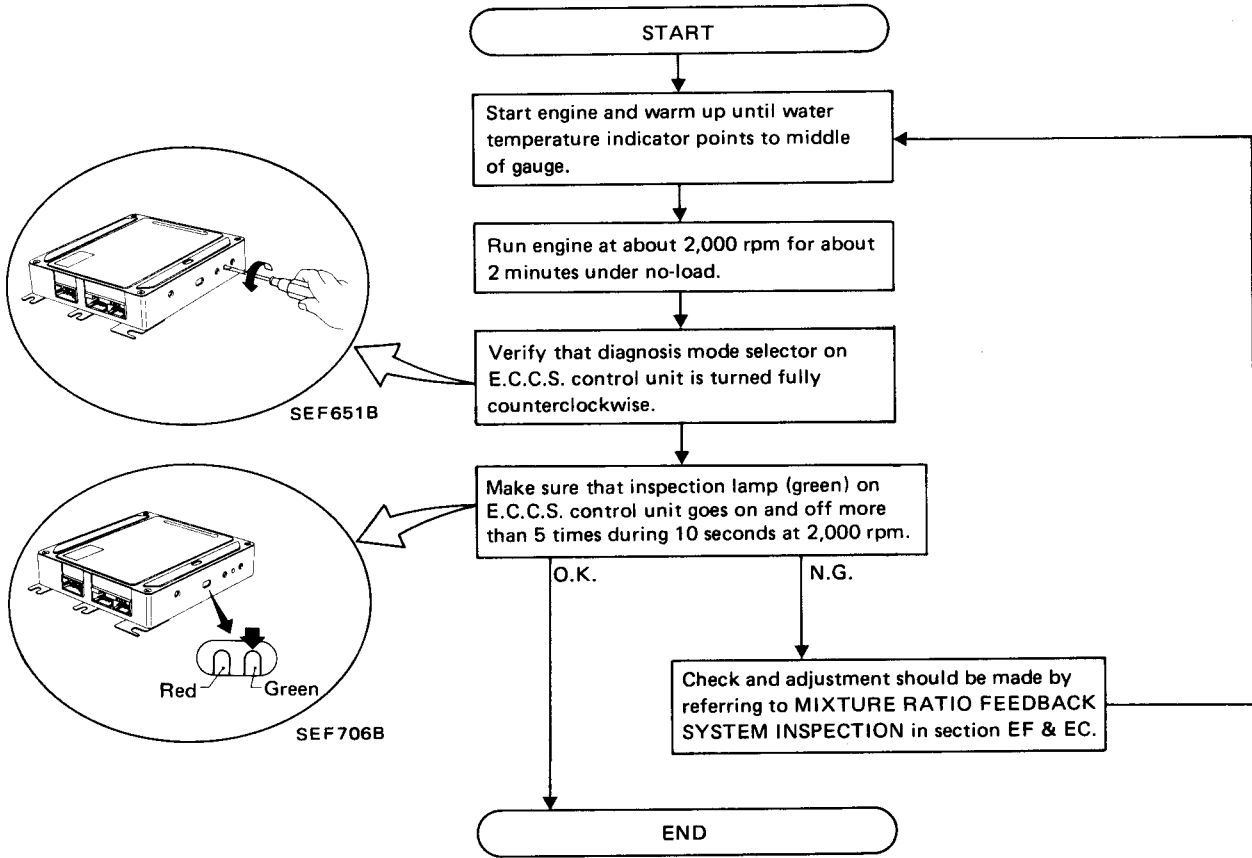

ENGINE MAINTENANCE

Checking Exhaust Gas Sensor

FOR U.S.A. MODELS

Every 30,000 miles (48,000 km) service

Exhaust gas sensor should be checked after every 30,000 miles (48,000 km) of operation.

After vehicle has been operated for 30,000 miles (48,000 km), exhaust gas sensor warning lamp will come on to indicate that sensor should be inspected.

After inspection, reset warning lamp hold relay so that warning lamp will come on after the next 30,000 miles (48,000 km).

Digital type

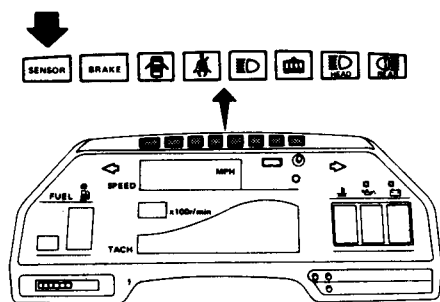

Needle type

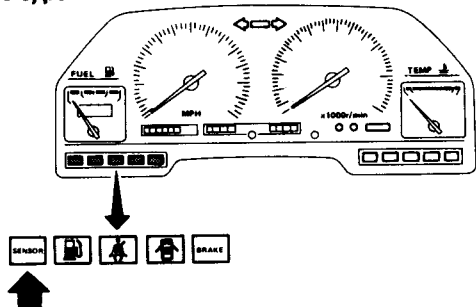

SMA791A

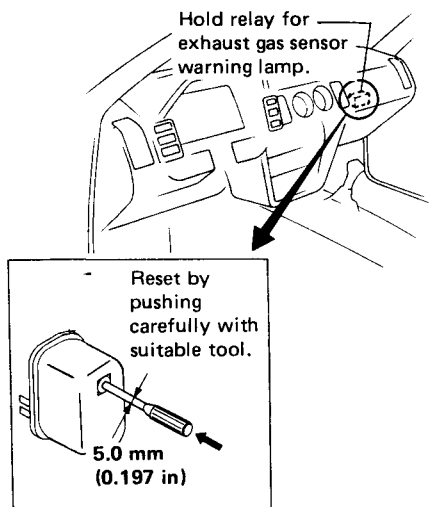

SMA233B

If sensor should be checked at 90,000 miles (144,000 km) of operation (After the third inspection), disconnect warning lamp harness connector.

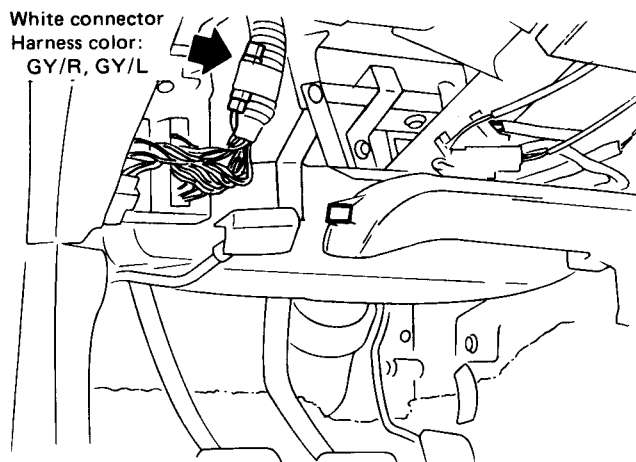

SMA792A

FOR CANADA MODELS

48,000 km (30,000 miles) service

Exhaust gas sensor should be checked after 48,000 km (30,000 miles) of operation.

The exhaust gas sensor warning lamp will come on at 48,000 km (30,000 miles) to indicate that sensor should be inspected.

After the inspection, disconnect warning lamp harness connector.

ENGINE MAINTENANCE

Replacing Timing Belt

After removing timing belt, do not rotate crankshaft and camshaft separately, because valves will hit piston heads.

1. Remove engine undercover and drain engine coolant from radiator.

Be careful not to allow coolant to contact drive belts.

2. Remove radiator shroud and fan.
3. Remove the following belts.
 - Power steering drive belt
 - Compressor drive belt
 - Alternator drive belt
4. Remove upper and lower radiator hoses.
5. Set No. 1 cylinder at T.D.C. on its compression stroke.

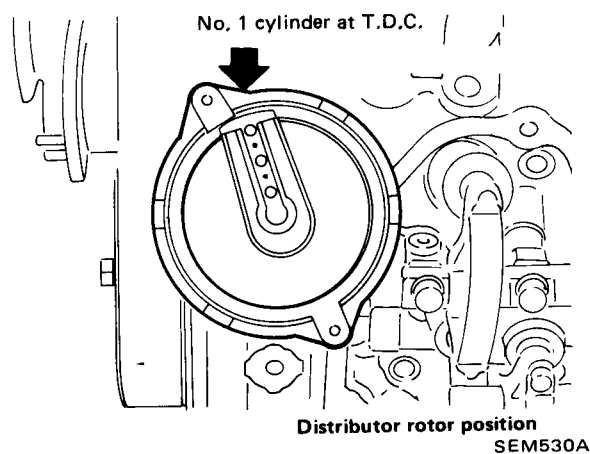
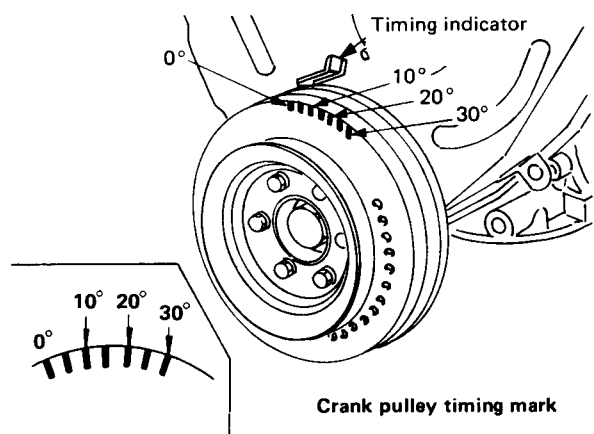

6. Remove idler bracket of the compressor drive belt and crankshaft pulley.
7. Remove front upper and lower belt covers.
8. Replace timing belt by loosening timing belt tensioner and return spring.

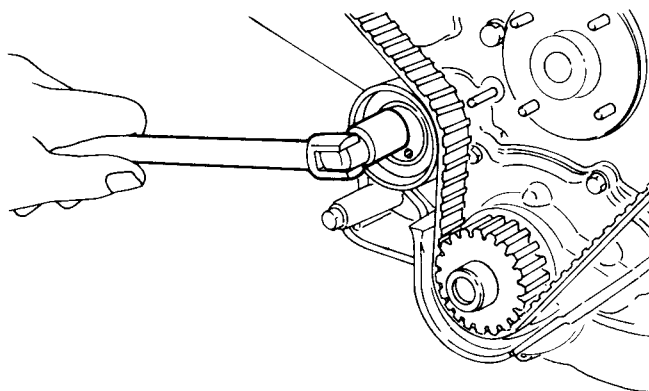

9. Visually check the condition of the timing belt. Refer to EM section.
10. Confirm that No. 1 cylinder is set at T.D.C. on its compression stroke.

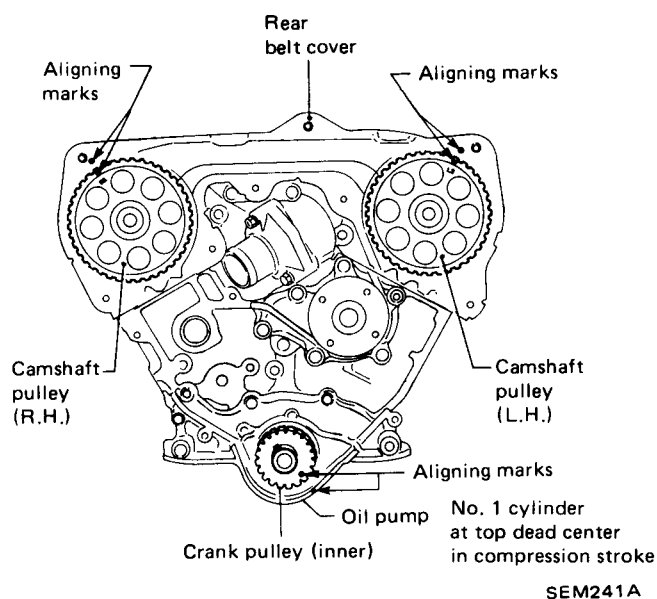

11. Disconnect all hoses, connectors and wires attached to intake collector and rocker covers.

ENGINE MAINTENANCE

Replacing Timing Belt (Cont'd)

12. Remove compressor from compressor bracket and secure with a suitable wire or rag to the body.
13. Remove collector cover and intake collector.
14. Remove both rocker covers and loosen all rocker shaft securing bolts.

Loosen all rocker shaft securing bolts thoroughly so that timing belt tension can be adjusted correctly. Otherwise, proper belt tension cannot be obtained.

15. Install tensioner and return spring.

If coarse stud is once removed, apply locking sealer to threads of stud before installing.

16. Turn tensioner clockwise with hexagon wrench and temporarily tighten tension lock nut.

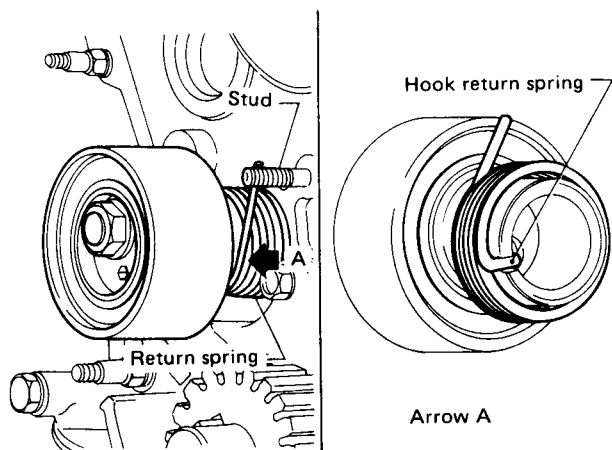

17. Set timing belt.

- a. Ensure timing belt is clean and free from oil or water. Do not bend it.
- b. Align white lines on timing belt with punch mark on camshaft pulleys and crankshaft pulley.
- c. Have arrow on timing belt pointing toward front belt covers.

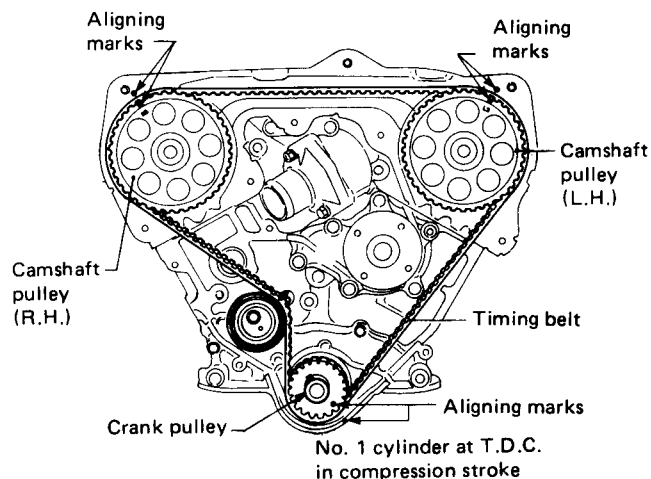

18. Loosen tensioner lock nut.
19. Slowly turn tensioner with hexagon wrench clockwise and counterclockwise two or three times.

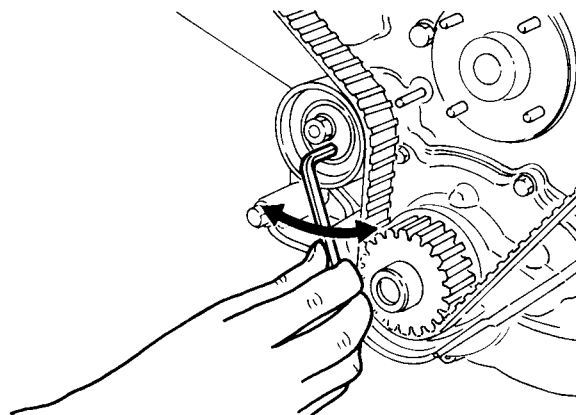

20. Tighten tensioner lock nut.

 : 43 - 58 N·m
(4.4 - 5.9 kg-m, 32 - 43 ft-lb)

ENGINE MAINTENANCE

Replacing Timing Belt (Cont'd)

21. Tighten rocker shaft securing bolts in two or three stages.

 **18 - 22 N·m**
(1.8 - 2.2 kg-m, 13 - 16 ft-lb)

R.H. rocker shafts

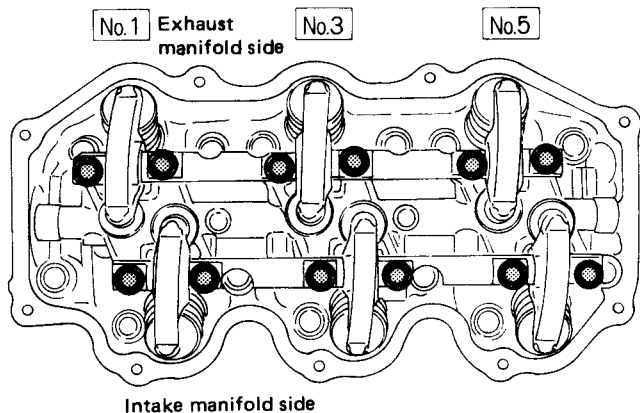

L.H. rocker shafts

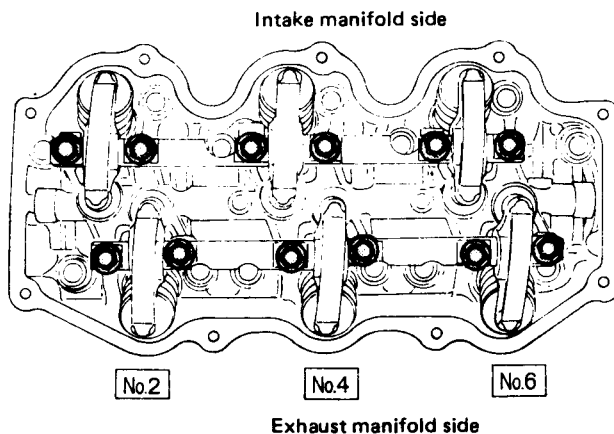

SEM245A

Before tightening, be sure to set camshaft lobe at the position where lobe is not lifted.

22. Install lower and upper belt covers.

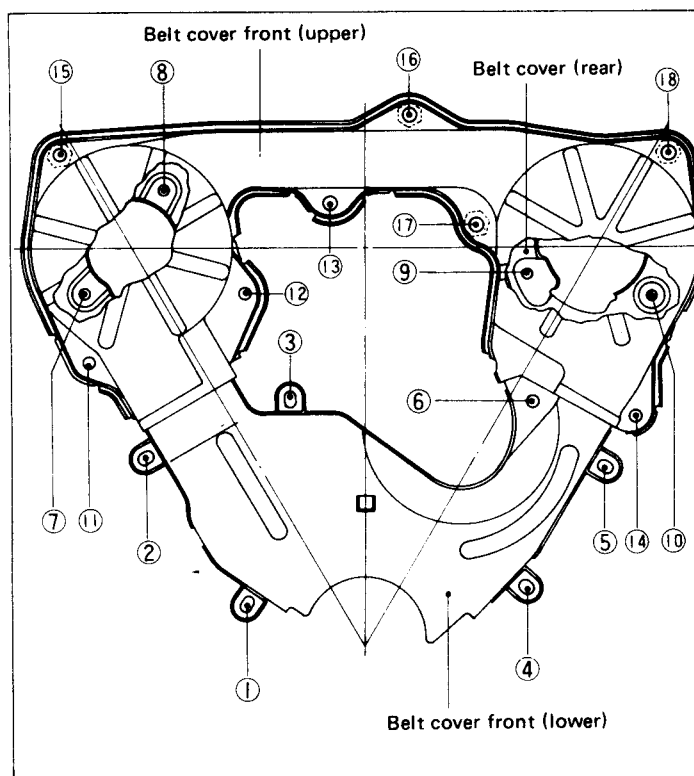

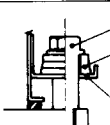
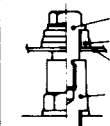
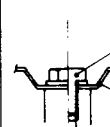
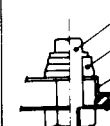
Tightened parts	Section	Parts tightened with bolts
 Bolt A (6 pcs.) Rubber washer Bolt cover front (lower)	1, 2, 3, 4, 5, 14	1, 2, 3, 4: Cylinder block 5, 14: Compressor bracket
 Bolt B (1 pc.) Rubber washer Bolt cover front (lower) Water pump mounting bolt	6	Water pump mounting bolt
 Bolt C (4 pcs.) Bolt cover (rear)	7, 8, 9, 10	Cylinder head
 Bolt A (7 pcs.) Rubber washer Bolt cover front (upper) Bolt cover (rear) Welded nut (4 pcs.)	15, 16, 17, 18, 11, 12, 13	15, 16, 17, 18: Welded nuts 11, 12: Cylinder head 13: Water outlet

SEM248A

ENGINE MAINTENANCE

Replacing Timing Belt (Cont'd)

23. Install rocker covers, intake collector and intake manifold.
24. Connect hoses, connectors and wires.
25. Install compressor to the engine.
26. Install crankshaft pulley and idler bracket of the compressor drive belt.

 : Crankshaft pulley bolt
 123 - 132 N·m
 (12.5 - 13.5 kg·m, 90 - 98 ft·lb)

27. Install lower and upper radiator hoses.
28. Install the drive belts.

Non-turbo model

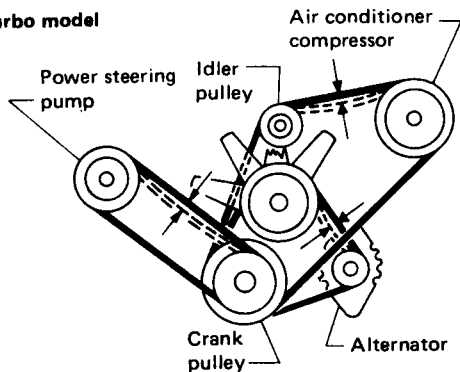

Turbo model

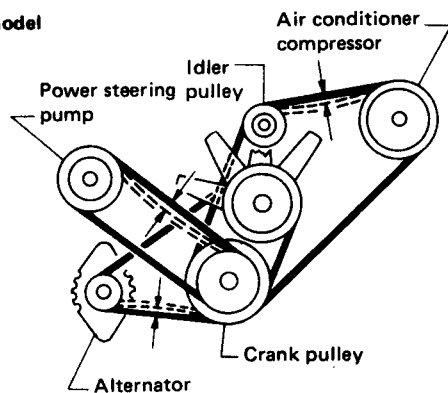

SEM239A

Unit: mm (in)

		Adjusted deflection of used belt	Set deflection of new belt
Alternator	VG30E	6 - 8 (0.24 - 0.31)	5 - 7 (0.20 - 0.28)
	VG30ET	6 - 9 (0.24 - 0.35)	5 - 8 (0.20 - 0.31)
Air conditioner compressor		9 - 11 (0.35 - 0.43)	7 - 9 (0.28 - 0.35)
Power steering oil pump		13 - 16 (0.51 - 0.63)	10 - 13 (0.39 - 0.51)
Applied pushing force		98 N (10 kg, 22 lb)	

29. Install fan and radiator shroud.
30. Fill radiator with engine coolant up to filler opening.

Slowly pour coolant through coolant filler neck to allow air in system to escape.

31. Fill reservoir tank up to "MAX" level. Then close radiator cap.
32. Run the engine at approximately 2,000 rpm until it warms up.
33. Check area around radiator drain plug and radiator hoses for any sign of water leakage.
34. Stop the engine and after it cools down, refill the radiator and engine with coolant up to the filler opening. Fill the reservoir tank with coolant up to "MAX" level.

CHASSIS AND BODY MAINTENANCE

Checking Exhaust System

Check exhaust pipes, muffler and mounting for proper attachment, leaks, cracks, damage, loose connections, chafing or deterioration.

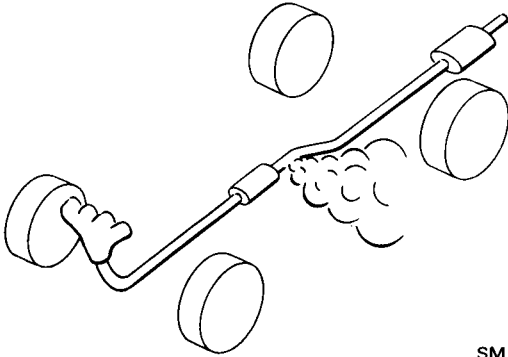

SMA211A

Checking Clutch Operation

Check clutch pedal height, free travel and smooth operation.

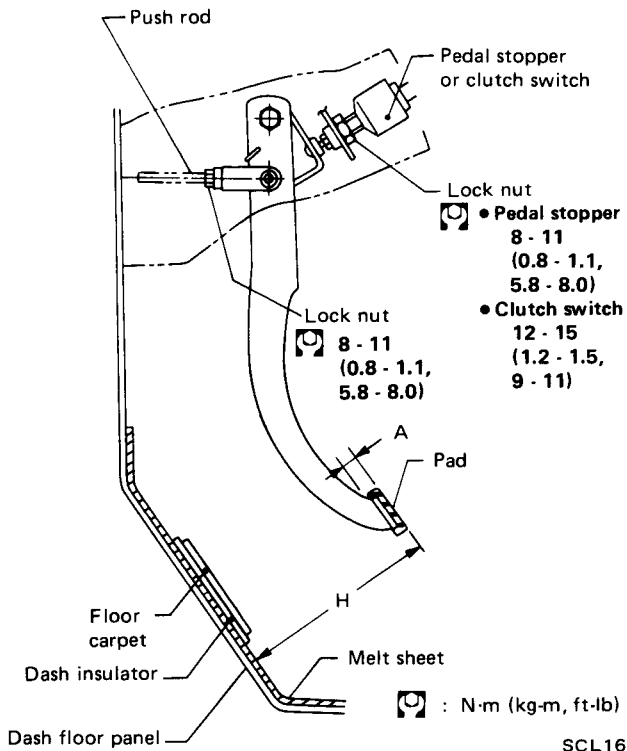

Pedal free height "H":

195 - 205 mm (7.68 - 8.07 in)

Pedal free travel "A":

1 - 3 mm (0.04 - 0.12 in)

Adjust clutch pedal free height and pedal free travel if necessary. Refer to section CL.

Checking Clutch Fluid Level

If fluid level is extremely low, check clutch system for leaks.

Changing Clutch Fluid

CAUTION:

- Refill with recommended brake fluid "DOT 3".
- Do not reuse drained brake fluid.
- Be careful not to splash brake fluid on painted areas.

1. Drain the fluid with the air bleeder valve.

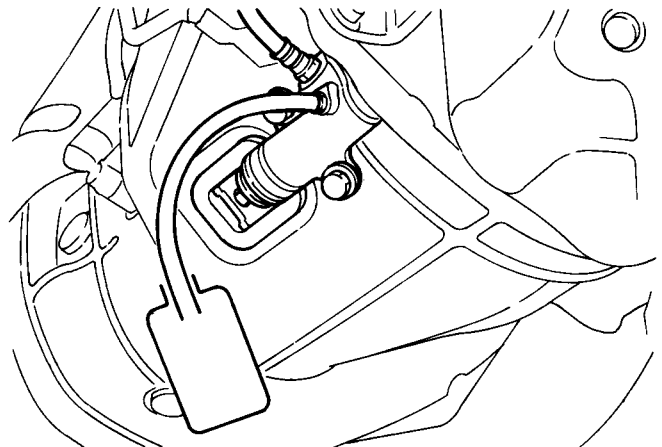

SCL203

2. Refill until the new fluid comes out in the air bleeder valve.

Use same procedure as in bleeding hydraulic system to refill the fluid.

Refer to section CL.

CHASSIS AND BODY MAINTENANCE

Checking Clutch System

Check clutch fluid lines for proper attachment, leaks, chafing, deterioration, etc.

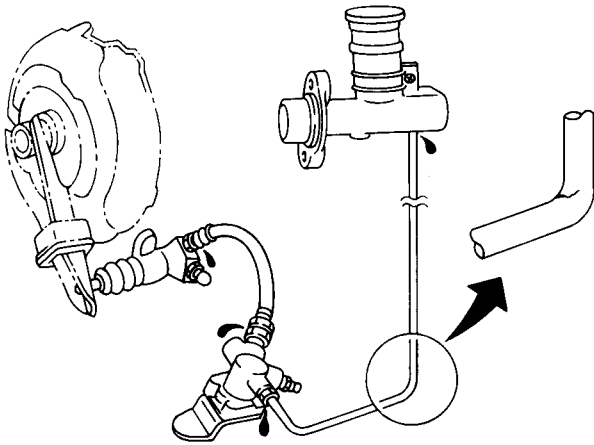

SMA741A

Checking M/T Oil

1. Check manual transmission for oil leakage.

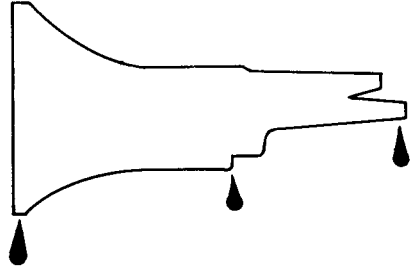

SMA429A

2. Check oil level.

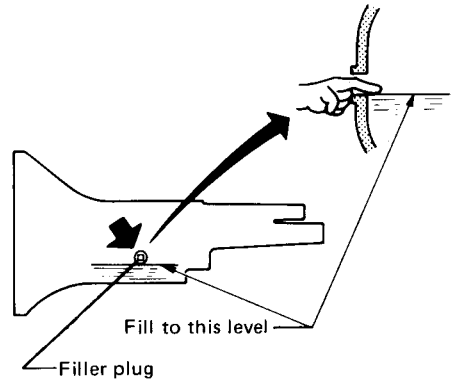

SMA103

CAUTION:
Never start engine while checking oil level.

Changing M/T Oil

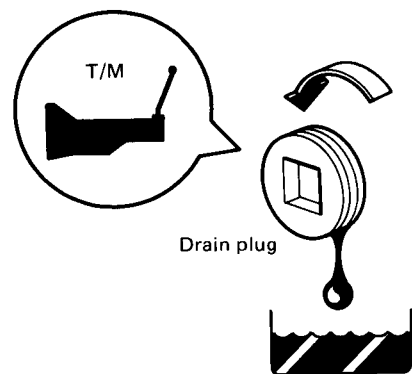

SMA255A

Oil capacity:
FS5W71C and BW T-5 (FS5R90A)
1.9 Liters (4 US pt, 3-3/8 Imp pt)

CHASSIS AND BODY MAINTENANCE

Checking A/T Fluid

1. Check automatic transmission for oil leakage.

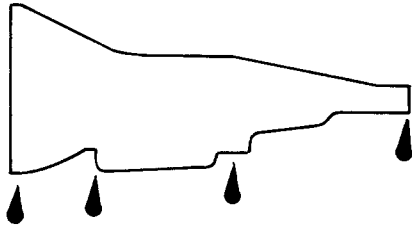

SMA430A

2. Check under following conditions.

- (1) Place selector lever in "P" (PARK) position and idle engine.
 - (2) Maintain fluid temperature at 50 to 80°C (122 to 176°F).
 - (3) Add oil, if necessary.
- Use only A/T fluid having "DEXRON".

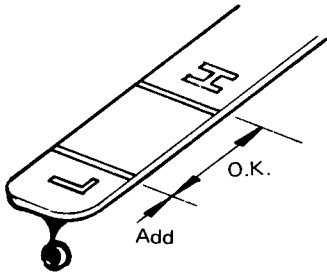

SMA559A

3. Check automatic fluid condition.
Check fluid for contamination of automatic transmission. If fluid is very dark or smells burned, the frictional material (clutches, band, etc.) may need replacement.

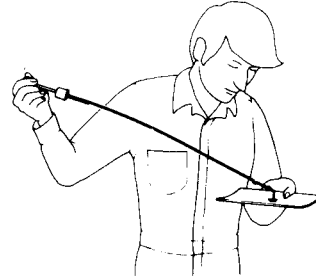

Check fluid for contamination.

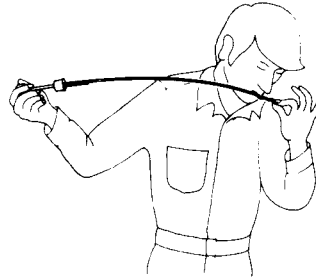

Check fluid for smell.

SMA107

CHASSIS AND BODY MAINTENANCE

Changing A/T Fluid

1. Drain fluid by removing oil pan.
2. Replace gasket with new one.
3. Refill with fluid and then check fluid level.

Oil capacity:

7.0 liters (7-3/8 US qt, 6-1/8 Imp qt)

Checking Propeller Shaft

Check propeller shaft for damage, looseness or grease leakage.

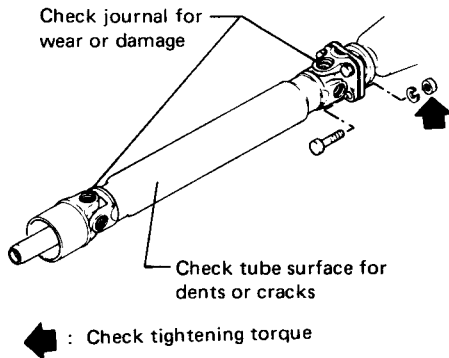

SMA269

Checking Differential Gear Oil

1. Check differential carrier for oil leakage.

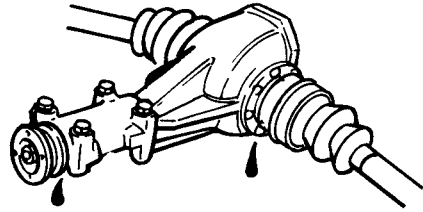

SMA432A

2. Check oil level.

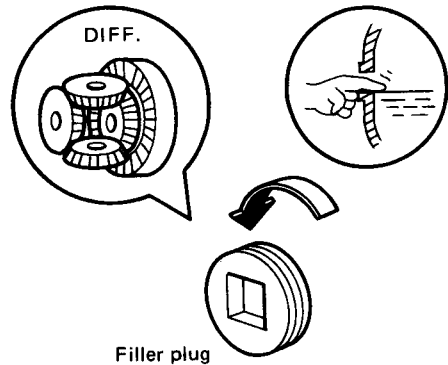

SMA257A

Changing Differential Gear Oil

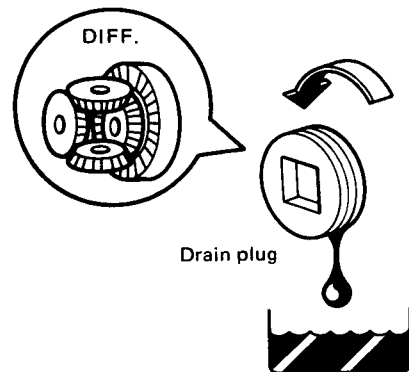

SMA363A

Oil capacity:

1.3 Liters (2-3/4 US pt, 2-1/4 Imp pt)

CHASSIS AND BODY MAINTENANCE

Checking Front Axle and Front Suspension Parts

- Check axle and suspension parts for looseness, wear or damage.

(1) Shake each front wheel.

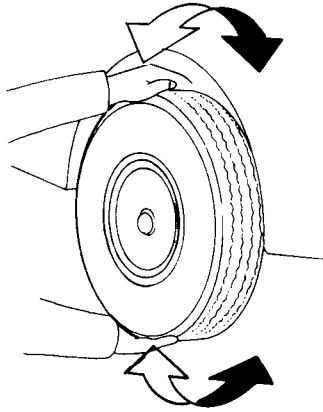

SMA525A

(2) Retighten all nuts and bolts to the specified torque.

Refer to section FA for tightening torque.

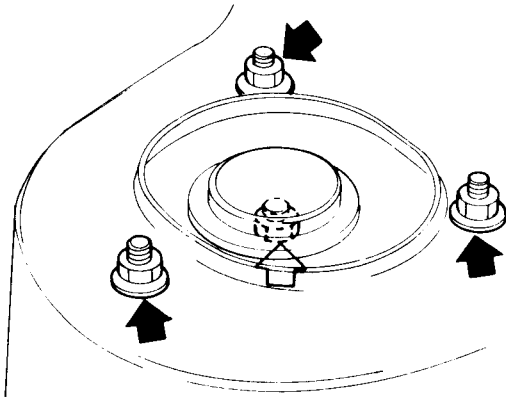

SMA614

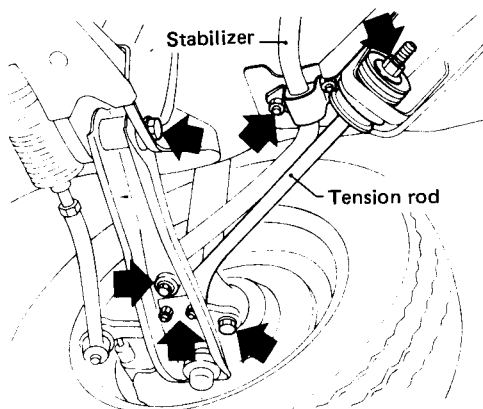

SMA615

(3) Check axle and suspension parts for wear, cracks or damage.

- Check strut (Shock absorber) for oil leakage or damage.

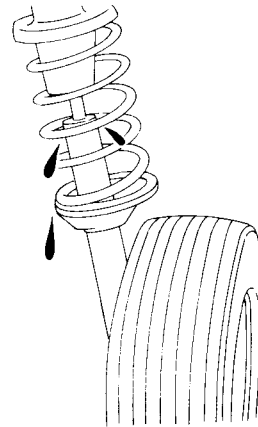

SMA113

Checking Steering Linkage Ball Joint & Suspension Ball Joint

- Check ball joint for grease leakage or other damage.

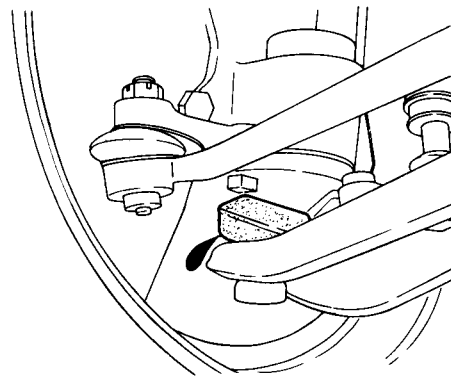

SMA723A

CHASSIS AND BODY MAINTENANCE

Checking Front Wheel Bearing Grease

- Check that wheel bearings operate smoothly, as well as axial end play and grease leakage.

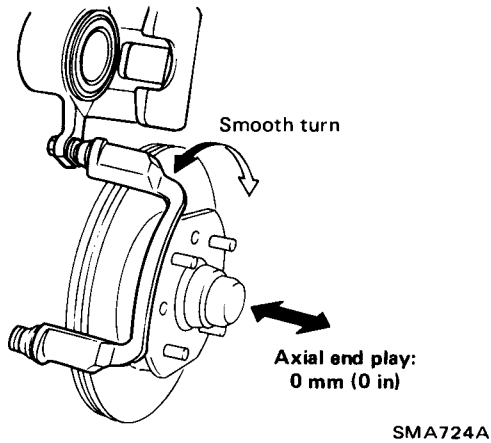

If necessary, adjust wheel bearing preload. Refer to section FA.

Checking Rear Axle and Rear Suspension Parts

- Check axle and suspension parts for looseness, wear or damage.

(1) Shake each rear wheel.

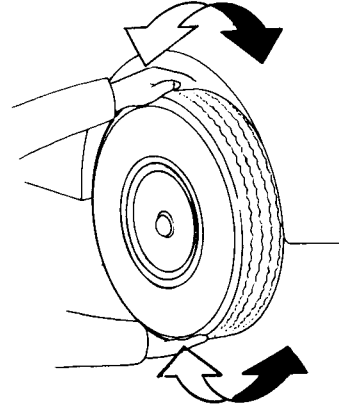

(2) Retighten all nuts and bolts to the specified torque.

Refer to section RA for tightening torque.

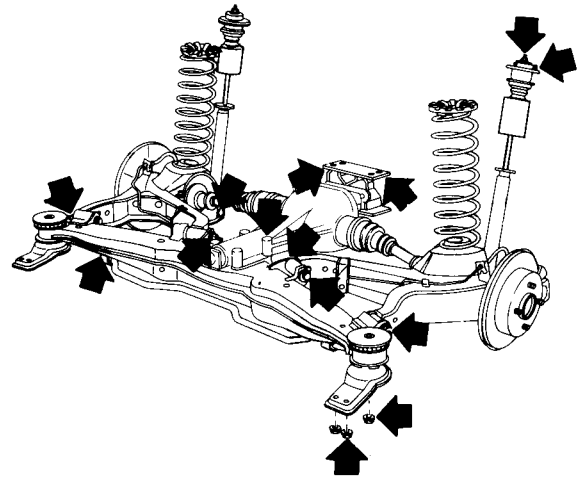

CHASSIS AND BODY MAINTENANCE

Checking Rear Axle and Rear Suspension Parts (Cont'd)

- (3) Check axle and suspension parts for wear, cracks or damage.
- Check shock absorber for oil leakage or damage.

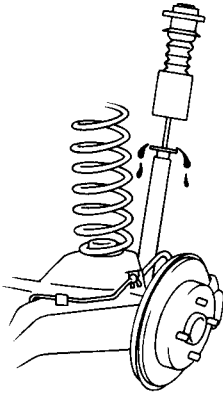

SMA726A

Checking Drive Shaft

Check boot and drive shaft for cracks, wear, damage or grease leakage.

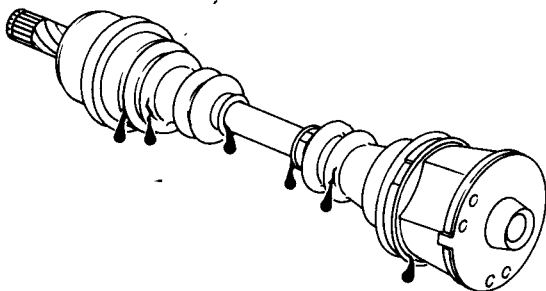

SMA743A

Checking Front Wheel Alignment

PRELIMINARY INSPECTION

- Tire pressure
- Wheel bearing axial play
- Suspension ball joint
- Steering gear housing looseness at frame
- Steering linkage and connections
- Shock absorber operation
- Tighten front axle and suspension parts.
- Measure vehicle height (Unladen).
The vehicle needs to be on a level surface.
- Repair or replace the damaged portion or parts.

"Unladen"

Fuel tank, radiator and engine oil pan are filled up.
Spare tire, jack, hand tools, mats are in position.

CAMBER, CASTER AND KINGPIN INCLINATION

Camber, caster and kingpin inclination are preset at factory and cannot be adjusted.

Camber:

-35' to 55'

Caster:

5° 50' - 7° 20'

Kingpin inclination:

12° 15' - 13° 45'

TOE-IN

1. Mark a base line across the tread.

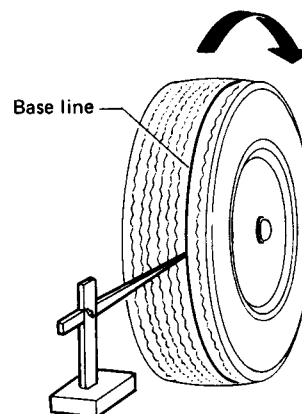

SMA123

After lowering front of vehicle, move it up and down to eliminate friction.

CHASSIS AND BODY MAINTENANCE

Checking Front Wheel Alignment (Cont'd)

2. Measure toe-in.

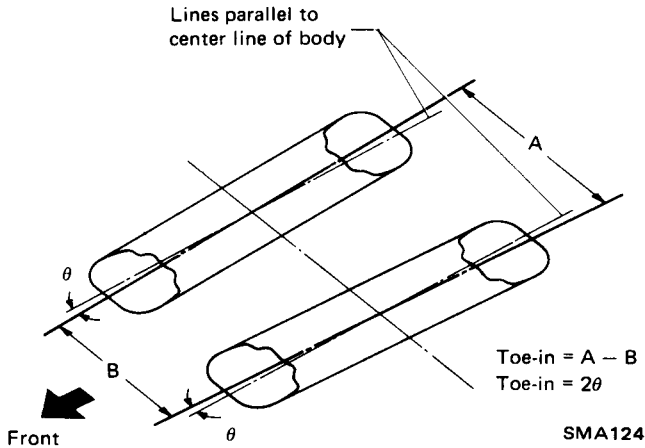

Toe-in:

1 - 3 mm (0.04 - 0.12 in)
6' - 17' (Total toe-in)

3. Toe-in can be adjusted by varying the length of steering side rods.

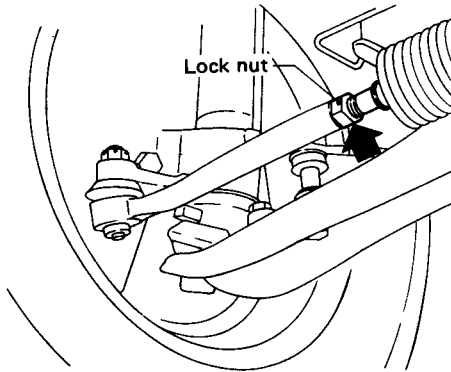

SMA727A

"A" standard dimension:

42.9 mm (1.689 in)

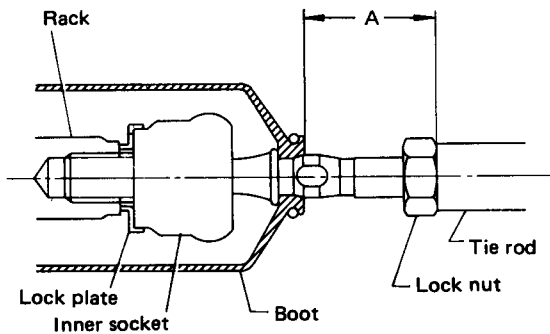

SST214A

FRONT WHEEL TURNING ANGLE

- Rotate steering wheel all the way right and left; measure turning angle on inner wheel.

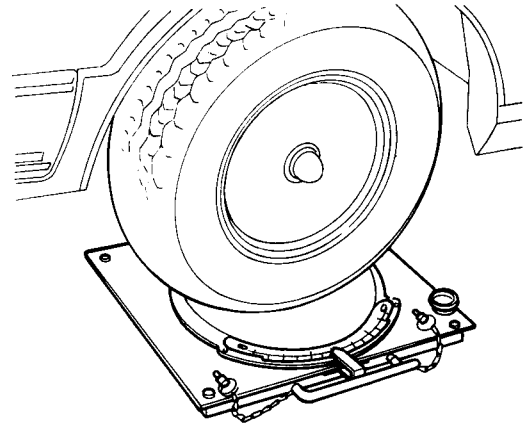

SMA127

Turning angle:

Full turns

Inside

35° - 39°

Outside

27° - 31°

Toe-out turn (Inside/Outside):

22° 30' / 20°

- If it is not within specification, check rack stroke.

Refer to section ST.

Rack stroke

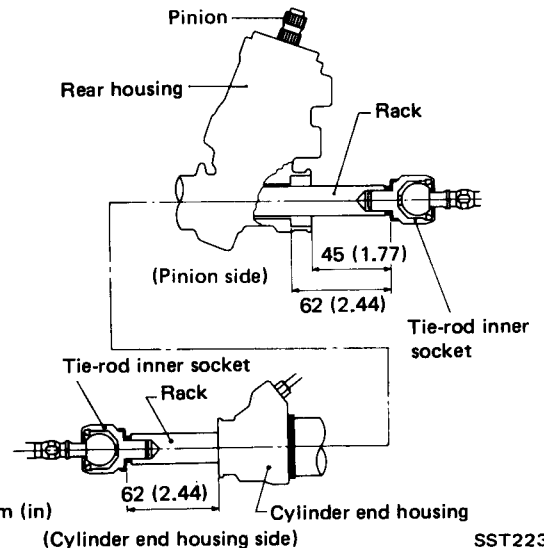

SST223A

CHASSIS AND BODY MAINTENANCE

Checking Rear Wheel Alignment

PRELIMINARY INSPECTION

- Tire pressure.
- Wheel bearing axial play.
- Shock absorber operation.
- Tighten rear axle and suspension parts.
- Measure vehicle height (Unladen)
The vehicle requires to be on a level surface.
- Repair or replace the damaged portion or parts.

“Unladen”

Fuel tank, radiator and engine oil pan are filled up.
Spare tire, jack, hand tools, mats are in position.

CAMBER

Camber is preset at factory and cannot be adjusted.

Camber:

$-1^{\circ}55'$ to $-25'$

TOE-IN

1. Mark a base line across the tread.

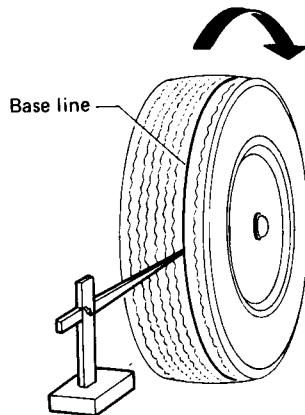

SMA123

2. Measure toe-in.

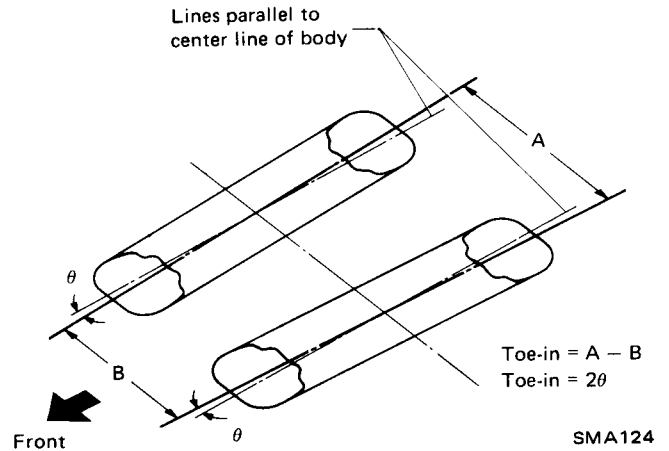

SMA124

Toe-in:

-1.5 to 2.5 mm (-0.059 to 0.098 in)

$-8'$ to $14'$ (Total toe-in)

3. Toe-in can be adjusted by inside of rear arm bushing pins.

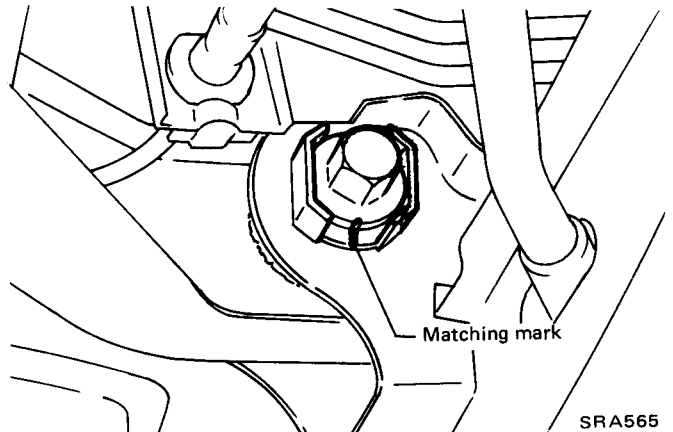

SRA565

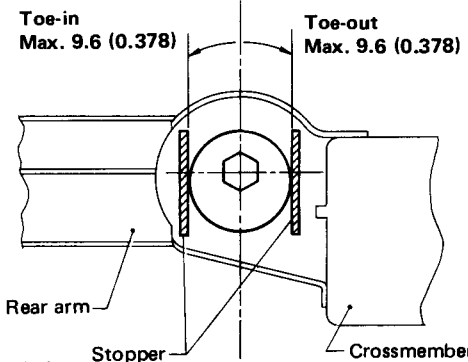

SMA745A

When performing toe adjustment, always set the cams in the same position on the right and left rear arm bushing pins.

CHASSIS AND BODY MAINTENANCE

Checking Brake Fluid Level and Leaks

If fluid level is extremely low, check brake system for leaks.

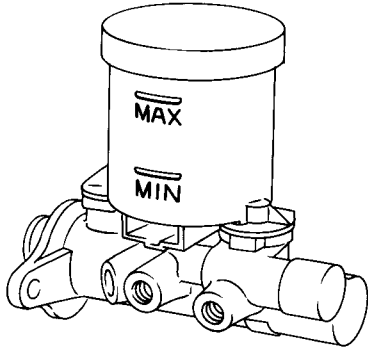

SMA730A

Checking Brake Lines & Hoses

BRAKE BOOSTER

Check vacuum lines connections and check valve for proper attachment, air tightness, chafing or deterioration.

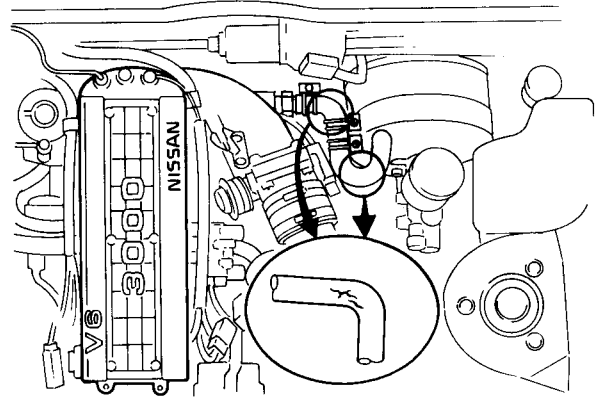

SBR986

BRAKE LINE

Check brake fluid lines and parking brake cables for proper attachment, leaks, chafing, abrasion or deterioration.

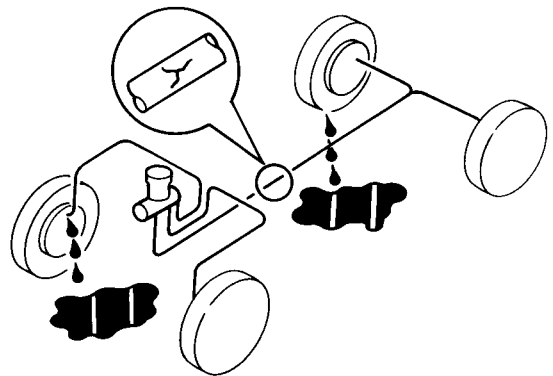

SMA732A

CHASSIS AND BODY MAINTENANCE

Checking Disc Brake

Check condition of disc brake components.

Rotor:

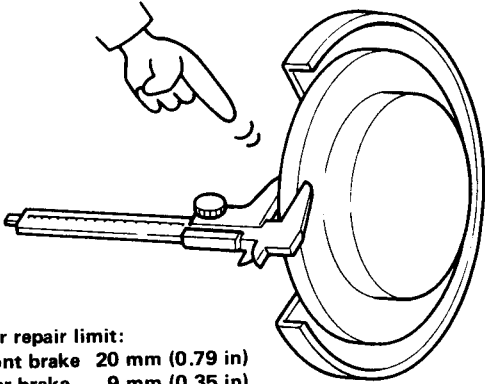

Rotor repair limit:
Front brake 20 mm (0.79 in)
Rear brake 9 mm (0.35 in)

SMA733A

Caliper: Oil leakage

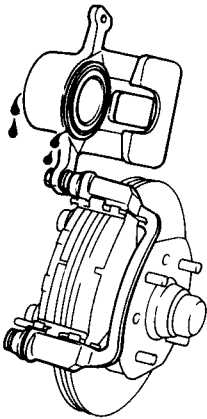

SMA734A

Pad: Wear or damage

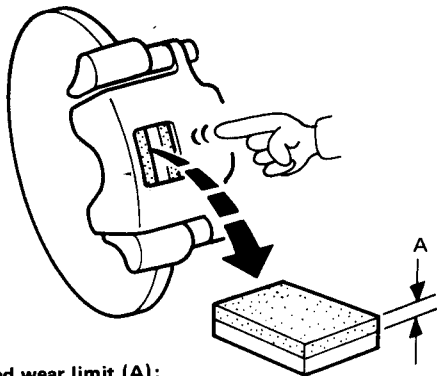

Pad wear limit (A):
2.0 mm (0.079 in)

SMA364A

Checking Foot Brake Pedal Operation

- Check brake pedal free height, depressed height and for smooth operation.

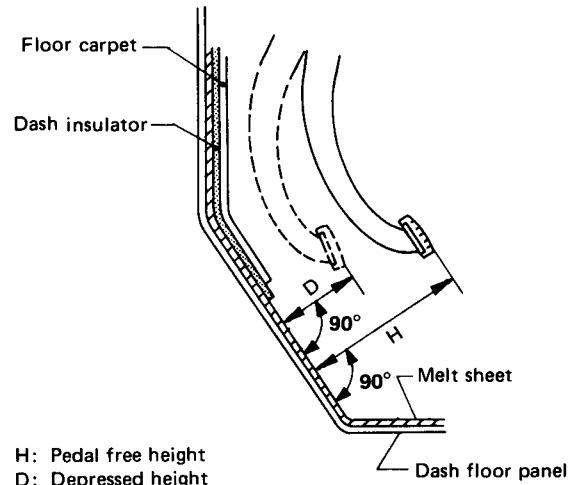

H: Pedal free height
D: Depressed height

SMA171B

Pedal free height "H":

M/T model 182 - 192 mm (7.17 - 7.56 in)

A/T model 184 - 194 mm (7.24 - 7.64 in)

Depressed height "D":

90 mm (3.54 in) or more

Adjust pedal height if necessary.
Refer to section BR.

CHASSIS AND BODY MAINTENANCE

Checking Parking Brake

Checking Tire Condition

- Pull lever with specified amount of force. Check lever stroke for smooth operation.

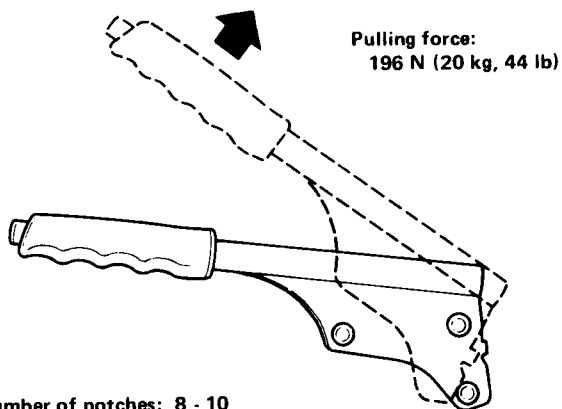

Number of notches: 8 - 10

SMA436

- Use adjuster to adjust lever stroke.

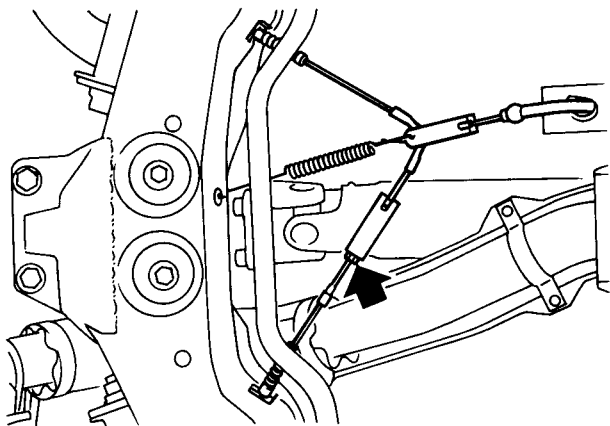

SMA735A

- Bend parking brake warning lamp switch plate down so that brake warning light comes on when ratchet at parking brake lever is pulled one notch and goes out when fully released.

TIRE CONDITION

- When tread wear indicators appear, replace them with new ones.

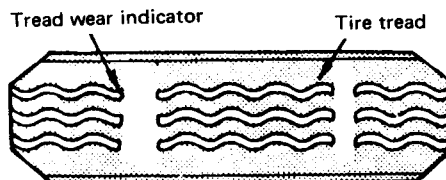

WH024

- Check tread and side walls for cracks, holes, separation or damage.

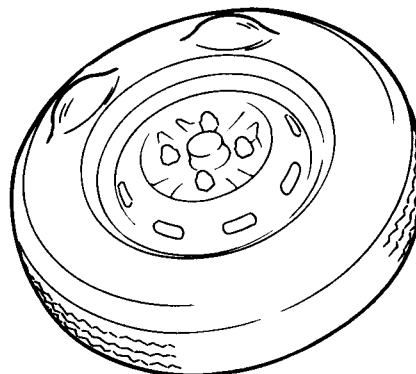

SMA539A

- Check tire valves for air leakage.

TIRE INFLATION

Tire pressure needs to be measured when tire is cold.

Tire pressure needs to be set to the specifications on the tire placard located in the vehicle.

CHASSIS AND BODY MAINTENANCE

Checking Tire Condition (Cont'd)

Abnormal tire wear

Correct abnormal tire wear according to the chart shown below.

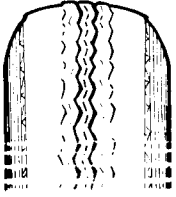
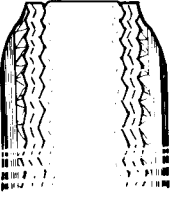
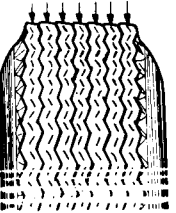
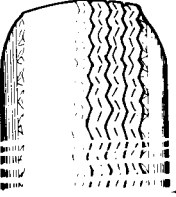
Condition	Probable cause	Corrective action
 <p>Shoulder wear</p>	<ul style="list-style-type: none"> • Underinflation (both sides wear) • Incorrect wheel camber (one side wear) • Hard cornering • Lack of rotation 	<ul style="list-style-type: none"> • Measure and adjust pressure. • Repair, or replace axle and suspension parts. • Reduce speed. • Rotate tires.
 <p>Center wear</p>	<ul style="list-style-type: none"> • Overinflation • Lack of rotation 	<ul style="list-style-type: none"> • Measure and adjust pressure. • Rotate tires.
 <p>Toe-in or toe-out wear</p>	<ul style="list-style-type: none"> • Incorrect toe 	<ul style="list-style-type: none"> • Adjust toe-in.
 <p>Uneven wear</p>	<ul style="list-style-type: none"> • Incorrect camber or caster • Malfunctioning suspension • Unbalanced wheel • Out-of-round brake drum • Other mechanical conditions • Lack of rotation 	<ul style="list-style-type: none"> • Repair, or replace axle and suspension parts. • Repair, replace or, if necessary, reinstall. • Balance or replace. • Correct or replace. • Correct or replace. • Rotate tires.

SMA068

Tire Rotation

Radial Tire

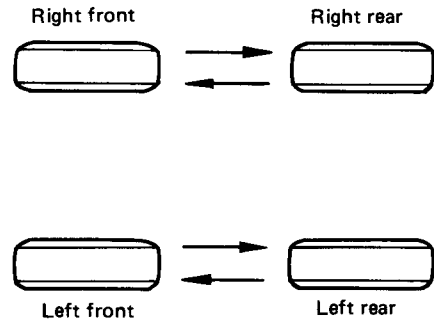

4 WHEELS

SMA736A

CHASSIS AND BODY MAINTENANCE

Tire Replacement

CAUTION:

- Do not mix different types of tires, such as bias, bias belted and radial tires under any circumstances.
- When replacing a tire, use a tire of the same size and type (Bias, Belted or Radial).
- Use recommended tires and wheels.
- Do not mix tires of different brands, tread patterns or type.
- When replacing standard tires with those of different diameter, the speedometer requires to be recalibrated.
- Tighten wheel nuts in criss-cross fashion.

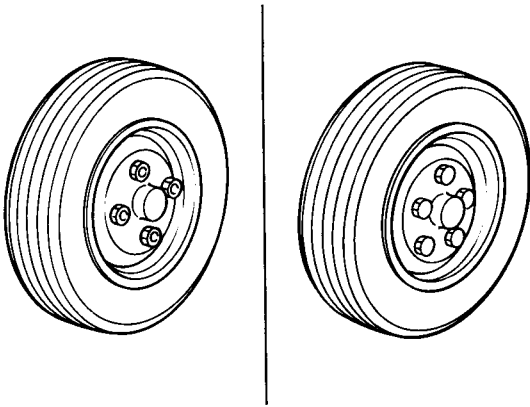

SMA737A

- To install an aluminum wheel, proceed as follows:

(1) Snugly tighten all nuts after the wheel is positioned.

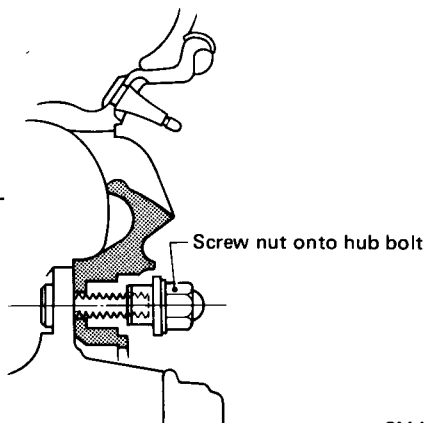

SMA070

(2) Pull the wheel back slightly to properly align the nuts with bolt holes in the wheel, and tighten the nuts as much as possible with your fingers.

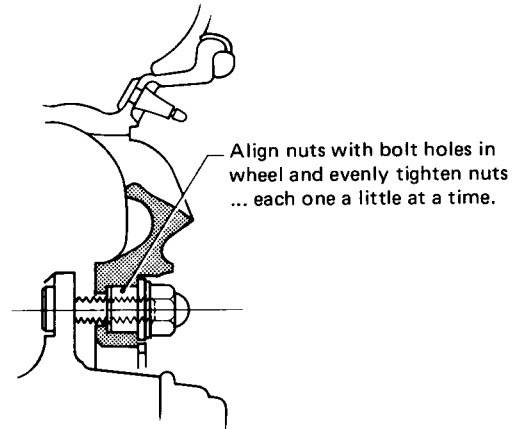

SMA071

(3) Tighten wheel nuts evenly with a wheel wrench in criss-cross fashion.

Check the wheel nuts for tightness, after the aluminum wheel has been run for the first 1,000 km (600 miles) (also in case of repairing flat tires or tire rotation.).

Replace if necessary.

CHASSIS AND BODY MAINTENANCE

Wheel Nut

CAUTION:

- Three types of wheel nuts are used; one is for steel wheels, one for aluminum wheels, and one for spare wheels. Do not mix different types of wheel nuts.
- Be careful not to smear threaded portion of bolt and nut as well as seat of nut with oil or grease.

For aluminum wheels only

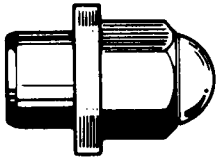

For spare wheels only



For steel wheels only

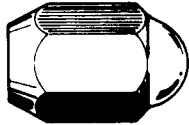

 78 - 98 N·m
(8.0 - 10.0 kg·m,
58 - 72 ft·lb)

SMA438

Tire Repair

CAUTION:

When replacing tire, be careful not to damage tire bead, rim-flange and bead seat.

When installing tire, note the following items:

- a. Install valve core and inflate to proper pressure. Make sure the locating rings of the tire are around the rim flanges on both sides.
- b. Check valves for leakage after inflating tires.
- c. Tighten valve caps firmly by hand.

WARNING:

To avoid serious personal injury, never stand over tire when inflating it. Never inflate to a pressure greater than 40 psi (275 kPa). If beads fail to seat at that pressure, deflate the tire, lubricate it again, and then reinflate it. If the tire is overinflated, the bead might break, possibly resulting in serious personal injury.

Wheel Inspection

- Check wheel rim (especially rim flange and bead seat) for rust, distortion, cracks or other damage.
- Examine wheel rim for lateral and radial runout, using dial gauge.

Lateral runout (A) and radial runout (B):

Steel wheel ... Less than
1.0 mm (0.039 in)

Aluminum wheel ... Less than
0.5 mm (0.020 in)

Difference between right and left lateral runout:

Steel wheel ... Less than
0.5 mm (0.020 in)

Aluminum wheel ... Less than
0.2 mm (0.008 in)

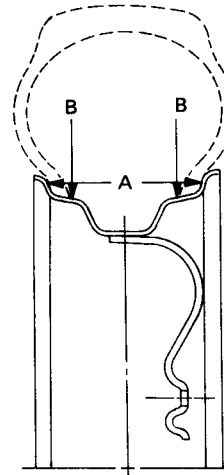

SMA140B

- Replace wheel when any of the following conditions occur.
 - a. Bent, dented or heavily rusted wheel
 - b. Elongated bolt holes
 - c. Excessive lateral or radial runout
 - d. Air leaks through welds
 - e. Loose wheel nut

CHASSIS AND BODY MAINTENANCE

Balancing Wheels

Spare Tire

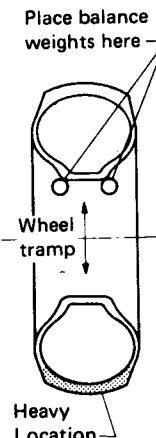
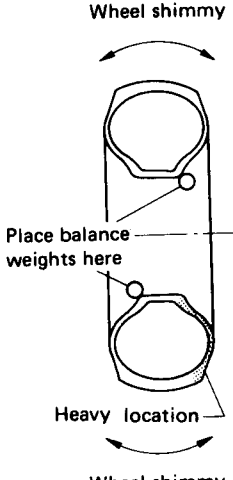
Cause	Wheel static unbalance	Wheel dynamic unbalance
Symptom of unbalance	Wheel tramp Wheel shimmy	Wheel shimmy
Corrective action	Balance statically 	Balance dynamically 

SMA075

This model is equipped with the Space Saver Spare tire or the Foldable Spare tire.

The spare tire is designed for emergency use only. It is stored in a deflated condition.

An inflator (canister or air pump) has been provided to inflate the spare.

The spare tire can be used repeatedly for emergency situations. The canister needs replacement after each inflation.

Use the proper size canister for spare tire size.

CAUTION:

The spare tire is restricted in driving speed up to a maximum of 80 km/h (50 MPH) for short distances and emergency use only.

INFLATION WITH APPROVED INFLATOR

1. Before changing tire, carefully read the caution and directions affixed on both the inflator and the spare tire.
2. Remove the uninflated spare tire and the inflator from rear compartment.

WARNING:

Do not inflate at this point.

3. Jack up front or rear of vehicle and remove the damaged tire. Then mount the uninflated spare tire to the axle. (Tighten wheel nuts slightly.)

Use spare wheel nuts in the tool bag on aluminum wheels equipped vehicles.

Do not use the wheel nuts for aluminum wheels on the spare tire wheel to avoid the wheel coming off the axle and causing personal injury.

4. Using Canister

- (1) With tire valve at 6 o'clock position, inflate the spare tire with the canister. Place tire canister on the tire inflation valve and push squarely until gas can be heard entering the tire. It may take 3 minutes.

WARNING:

The metal parts of the canister become extremely cold during inflation and can cause frost bite. Therefore, avoid contact with the metal, use a glove or other protection.

CHASSIS AND BODY MAINTENANCE

Spare Tire (Cont'd)

- (2) To ensure complete emptying of the canister, hold the canister in position for one minute after sound stops.
 - a. If temperature is below -10°C (14°F), the canister needs to be warmed on the windshield defroster for five to ten minutes to provide tire inflation.
 - b. In cold weather, the tire may not look fully inflated. Therefore, drive slowly for the first mile, as the tire temperature rises the pressure will increase.

Using Air Compressor

- (1) Remove the valve cap from the spare tire and securely connect the air pump hose in its place.
- (2) Connect the power cord plug of the air pump to the cigarette lighter socket. The spare tire may be inflated to the recommended pressure 28 psi (200 kPa) in about 6 minutes. Adjust the tire pressure per the tire placard with tire pressure gauge.

If the air pump works slowly, run the engine while the air pump is working. In this case, remove jack with the spare tire attached to the axle.

WARNING:

- Do not run the engine in a closed space or with the vehicle jacked up.
- Do not touch the air pump with the bare hands while it is working.

- (3) Disconnect the power cord plug from socket. Check the tire for air leakage, and then securely install and tighten the valve cap.
5. Lower car and fully tighten wheel nuts.

Do not install the wheel cover on the spare tire.

DEFLATION -

1. Deflate tire by depressing button on tire inflation valve or by removing valve core.

WARNING:

To avoid personal injury, do not inhale the gas which is vented while the tire is deflating.

2. Flatten tire. The spare tire becomes folded gradually while deflating.
3. Store tire in rear compartment.

REPAIR

Only qualified tire experts are authorized to dismount the spare tire from its rim or repair it in any way. Improper service can result in serious personal injury.

Contact agents of tire manufacturer, their dealers or NISSAN/DATSUN dealers if service is required.

CHASSIS AND BODY MAINTENANCE

Checking Steering Gear and Linkage

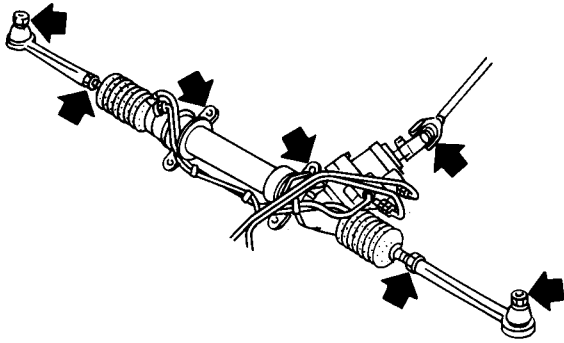

SMA738A

- Steering gear:
 - (1) Check gear housing and boots for looseness, damage or grease leakage.
 - (2) Check connection with steering column for looseness.
- Steering linkage:
 - (1) Check ball joint, dust cover and other component parts for looseness, wear, damage or grease leakage.
 - (2) Check for missing parts (cotter pins, washer, etc.).

Checking Power Steering System Fluid and Lines

- Check fluid level, when the fluid is cold.

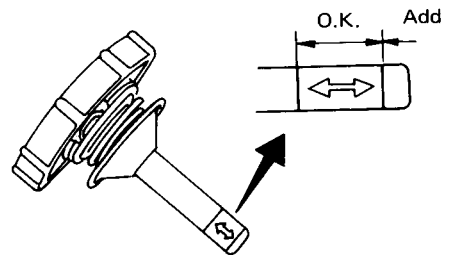

SMA750A

- Check lines for proper attachment, leaks, cracks, damage, loose connections, chafing and deterioration.

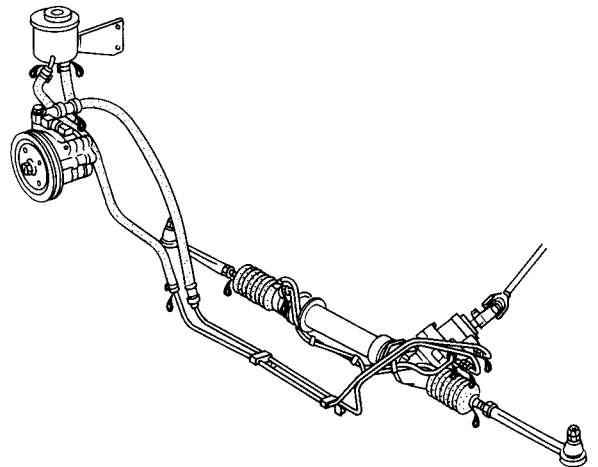

SMA739A

CHASSIS AND BODY MAINTENANCE

Body

LUBRICATING LOCKS, HINGES AND HOOD LATCHES

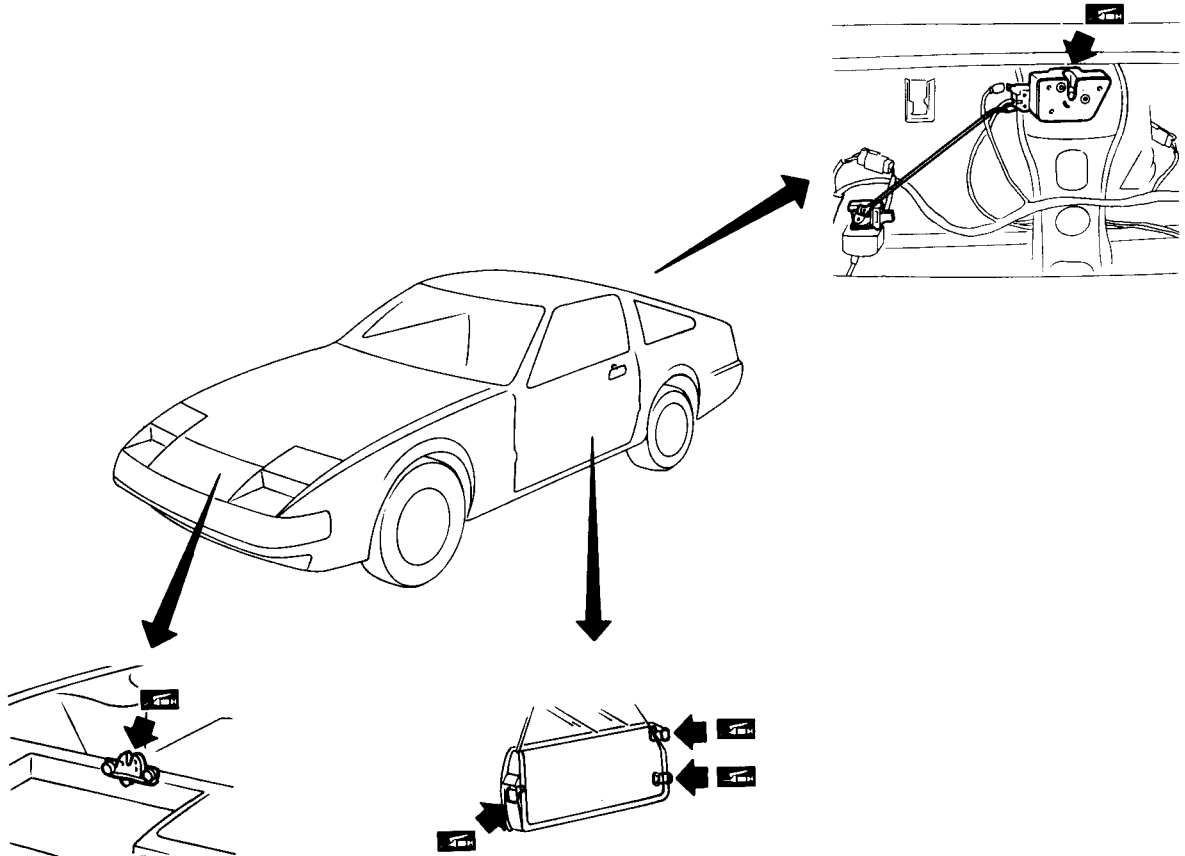

SMA707A

CHECKING SEAT BELTS, BUCKLES, RETRACTORS, ANCHORS AND ADJUSTERS

CAUTION:

1. If the vehicle is collided or overturned, replace the entire belt assembly, regardless of nature of accident.
2. If the condition of any component of a seat belt is questionable, do not have seat belt repaired, but replaced as a belt assembly.
3. If webbing is cut, frayed, or damaged, replace belt assembly.
4. Do not spill drinks, oil etc. on inner lap belt buckle. Never oil tongue and buckle.
5. Use a NISSAN genuine seat belt assembly.

 Anchor bolt
24 - 31 N·m
(2.4 - 3.2 kg-m, 17 - 23 ft-lb)

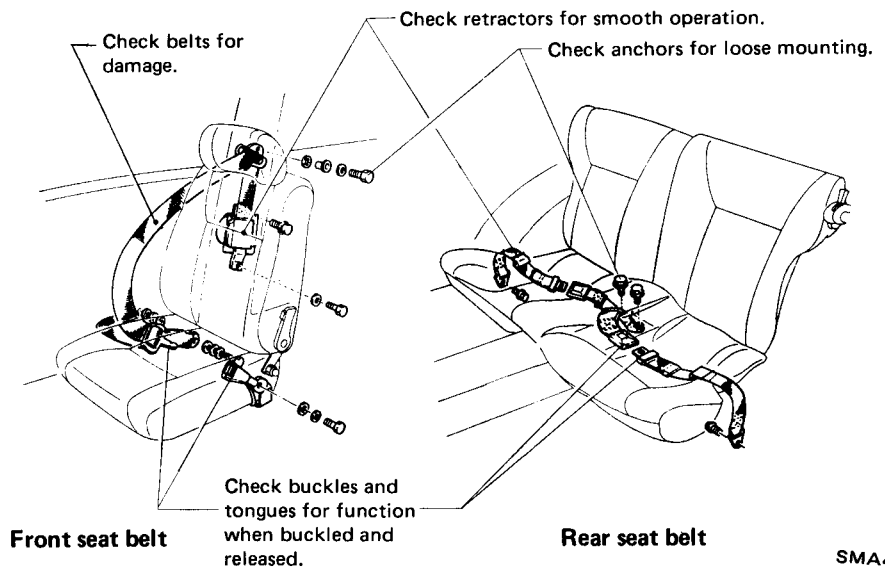

SMA443

SERVICE DATA AND SPECIFICATIONS (S.D.S.)

Engine Maintenance

Chassis and Body Maintenance

INSPECTION AND ADJUSTMENT

Drive belt deflection

Unit: mm (in)

		Used belt deflection		Set deflection of new belt
		Limit	Adjusted deflection	
Alternator	VG30E	12 (0.47)	6 - 8 (0.24 - 0.31)	5 - 7 (0.20 - 0.28)
	VG30ET	11 (0.43)	6 - 9 (0.24 - 0.35)	5 - 8 (0.20 - 0.31)
Air conditioner compressor		16 (0.63)	9 - 11 (0.35 - 0.43)	7 - 9 (0.28 - 0.35)
Power steering oil pump		21 (0.83)	13 - 16 (0.51 - 0.63)	10 - 13 (0.39 - 0.51)
Applied pushing force		98 N (10 kg, 22 lb)		

Oil capacity (Refill)

Unit: ℓ (US qt, Imp qt)

	VG30E & VG30ET
With oil filter	4.0 (4-1/4, 3-1/2)
Without oil filter	3.6 (3-7/8, 3-1/8)

Coolant capacity

Unit: ℓ (US qt, Imp qt)

	Coolant capacity
VG30E	10.5 (11-1/8, 9-1/4)
VG30ET	11.0 (11-5/8, 9-5/8)
Reservoir tank	0.8 (7/8, 3/4)

Spark plug

	VG30E	VG30ET
Standard type	BCPR6ES-11	BCPR6E-11
Hot type	BCPR5ES-11	BCPR5E-11
Cold type	BCPR7ES-11	BCPR7E-11
Plug gap	1.0 - 1.1 mm (0.039 - 0.043 in)	

Ignition timing and idle speed

Unit: B.T.D.C. degree/rpm

	M/T	A/T (in "D" position)
VG30E	At sea level	20±2°/700±50
	At high altitude condition	20±2°/650±50
VG30ET	20 ± 2°/700 ± 50	20 ± 2°/650 ± 50

TIGHTENING TORQUE

Unit	N·m	kg·m	ft·lb
Oil pan drain plug	29 - 39	3.0 - 4.0	22 - 29
Spark plug	20 - 29	2.0 - 3.0	14 - 22
Fuel hose clamps	1.0 - 1.5	0.10 - 0.15	0.7 - 1.1

INSPECTION AND ADJUSTMENT

Clutch

Unit: mm (in)

Pedal height "H"	195 - 205 (7.68 - 8.07)
Pedal free play "A"	1 - 3 (0.04 - 0.12)

Front axle and front suspension

Axial play	mm (in)	0 (0)
Wheel bearing preload (As measured at wheel hub bolt)		6.86 - 14.61
With new parts	N (kg, lb)	(0.7 - 1.49, 1.54 - 3.29)
With used parts	N (kg, lb)	1.67 - 7.75 (0.17 - 0.79, 0.37 - 1.74)
Wheel alignment (Unladen)		
Camber	degree	-35' to 55'
Caster	degree	5° 50' - 7° 20'
Kingpin inclination	degree	12° 15' - 13° 45'
Toe-in	mm (in)	1 - 3 (0.04 - 0.12)
	degree	6' - 17' (Total toe-in)
Side slip (Reference data)	mm/m (in/ft)	Out 3 (0.036) - In 3 (0.036)
Standard side rod length "A"	mm (in)	37.5 (1.476)
Front wheel turning angle		
Toe-out turns		
Inner wheel/Outer wheel	degree	22° 30'/20°
Full turns		
Inner wheel	degree	35° - 39°
Outer wheel	degree	27° - 31°

* On power steering models, wheel turning force (at circumference of steering wheel) of 98 - 147 N (10 - 15 kg, 22 - 33 lb) with engine at idle.

Rear axle and rear suspension

Camber	degree	-1° 55' to -25'
Toe-in	mm (in)	-1.5 to 2.5 (-0.059 to 0.098)
	degree	-8' to 14' (Total toe-in)

SERVICE DATA AND SPECIFICATIONS (S.D.S.)

Chassis and Body Maintenance (Cont'd)

Brake

Unit: mm (in)

Pad wear limit	Front brake	2.0 (0.079)
	Rear brake	2.0 (0.079)
Rotor repair limit	Front brake	20 (0.79)
	Rear brake	9.0 (0.354)
Pedal free height "h"		
M/T model		182 - 192 (7.17 - 7.56)
A/T model		184 - 194 (7.24 - 7.64)
Pedal depressed height [Under force of 490 N (50 kg, 110 lb) with engine running]		90 (3.54) or more
Parking brake [at pulling force: 196 N (20 kg, 44 lb)] Number of notches		8 - 10

Wheel and tire

Tire inflation

Proper tire pressures are shown on the tire placard affixed to the driver's side center pillar of vehicle.

Spare tire C78-14	Do not use in excess of 80 km/h (50 MPH).
	28 psi (200 kPa)
Tire pressure should be checked when tires are COLD.	
Wheel rim lateral and radial runout	mm (in) Less than 1.0 (0.039)*1 0.5 (0.020)*2
Difference between right and left lateral runout	mm (in) Less than 0.5 (0.020)*1 0.2 (0.008)*2
Wheel balance (Maximum allowable unbalance at rim flange)	gr (oz) 10 (0.35)
Tire balancing weight	gr (oz) 5 - 60 (0.18 - 2.12) Spacing 5 (0.18)

*1: Steel wheel *2: Aluminum wheel

TIGHTENING TORQUE

Unit	N·m	kg·m	ft·lb
Clutch			
Pedal stopper lock nut	8 - 11	0.8 - 1.1	5.8 - 8.0
Clutch switch lock nut	12 - 15	1.2 - 1.5	9 - 11
Master cylinder push rod lock nut	8 - 11	0.8 - 1.1	5.8 - 8.0
Manual transmission			
Drain and filter plugs FS5W71C	25 - 34	2.5 - 3.5	18 - 25
FS5R90A	20 - 34	2.0 - 3.5	14 - 25
Differential carrier			
Drain and filler plugs	39 - 59	4 - 6	29 - 43
Front axle and front suspension			
Tie rod lock nut	78 - 98	8 - 10	58 - 72
Brake			
Air bleeder valve	7 - 9	0.7 - 0.9	5.1 - 6.5
Stop lamp switch lock nut	12 - 15	1.2 - 1.5	9 - 11
Brake booster input rod lock nut	16 - 22	1.6 - 2.2	12 - 16
Wheel and tire			
Wheel nut	78 - 98	8.0 - 10.0	58 - 72

SPECIAL SERVICE TOOLS

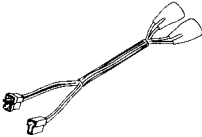
Tool number (Kent-Moore No.)	Tool name
EG11150000 (-)	Ignition coil adapter harness 
KV10105900 (J34274)	Oil filter wrench 