

# REAR AXLE & REAR SUSPENSION

## SECTION **RA**

### CONTENTS

PRECAUTIONS AND PREPARATION .....	RA- 2
REAR AXLE AND REAR SUSPENSION .....	RA- 4
CHECK AND ADJUSTMENT — On-vehicle .....	RA- 5
REAR AXLE — Wheel Hub and Axle Housing .....	RA- 8
REAR AXLE — Drive Shaft .....	RA-12
REAR SUSPENSION .....	RA-17
REAR SUSPENSION — Coil Spring and Shock Absorber .....	RA-19
REAR SUSPENSION — Multi-link and Lower Ball Joint .....	RA-21
REAR SUSPENSION — Stabilizer Bar .....	RA-23
ADJUSTABLE SHOCK ABSORBER .....	RA-24
ADJUSTABLE SHOCK ABSORBER — Trouble Diagnoses .....	RA-26
SUPER HICAS .....	RA-32
SERVICE DATA AND SPECIFICATIONS (S.D.S.) .....	RA-34

# PRECAUTIONS AND PREPARATION

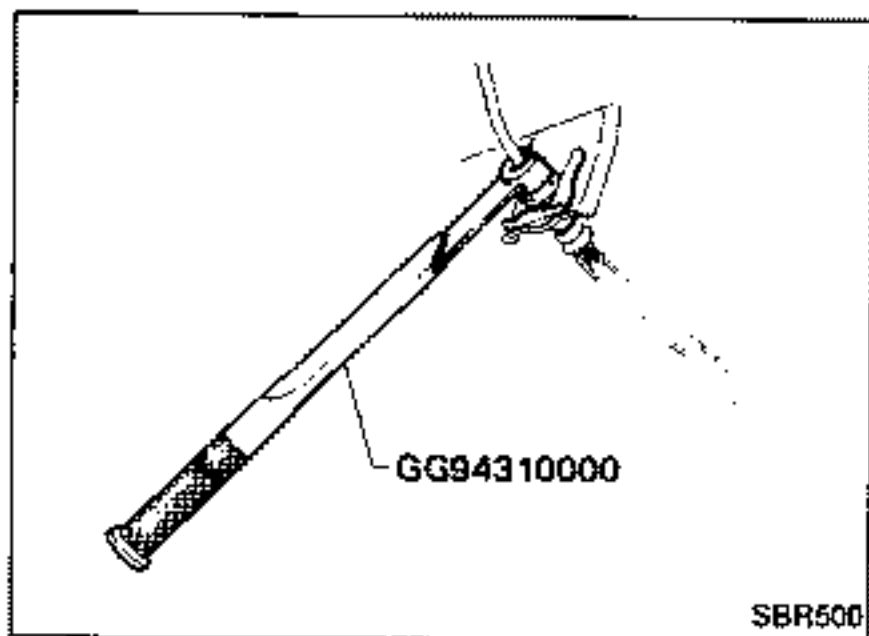



## Precautions

- When installing each rubber part, final tightening must be carried out under unladen condition\* with tires on ground.
- \* Fuel, radiator coolant and engine oil full. Spare tire, jack, hand tools and mats in designated positions.
- Use Tool when removing or installing brake lines.
- When removing each suspension part, check wheel alignment and adjust if necessary.
- Do not jack up at the lower arm.

## Preparation

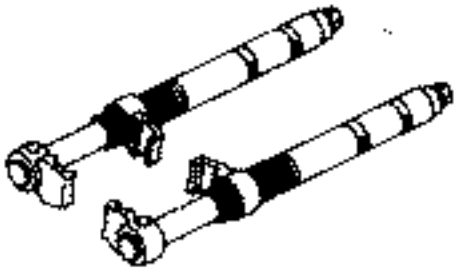
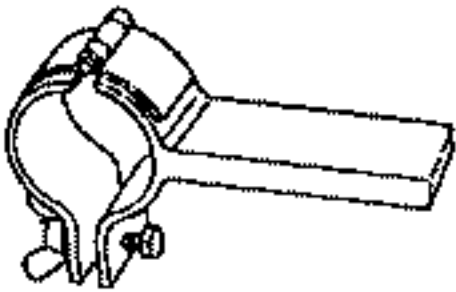

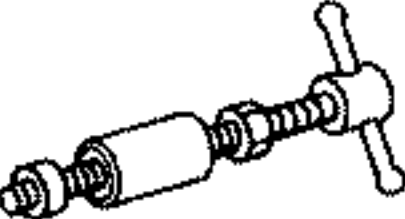
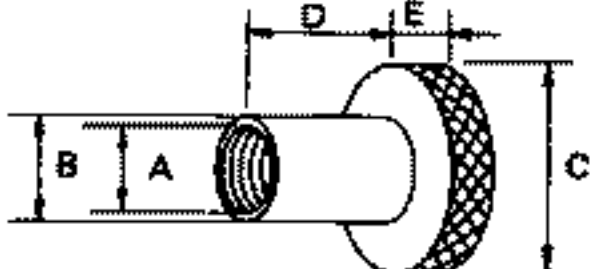
### SPECIAL SERVICE TOOLS

Tool number Tool name	Description
HT71780000 Spring compressor	 <p>Removing and installing coil spring</p>
ST35652000 Shock absorber attachment	 <p>Fixing strut assembly</p>
GG94310000 Flare nut torque wrench	 <p>Removing and installing brake piping</p>
ST30031000 Bearing puller	 <p>Removing inner race of wheel bearing</p>
ST38280000 Arm bushing remover	 <p>Removing and installing bushing of rear axle housing</p>
1M23600800 Attachment Wheel alignment	 <p>Measure rear wheel alignment</p> <p>A: Screw M24 x 1.5            B: 35 (1.38) dia.            C: 65 (2.56) dia.            D: 56 (2.20)            E: 12 (0.47)      Unit: mm (in)</p>

# PRECAUTIONS AND PREPARATION

## Preparation (Cont'd)

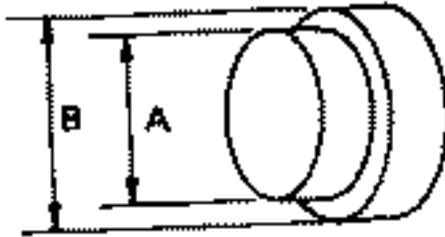
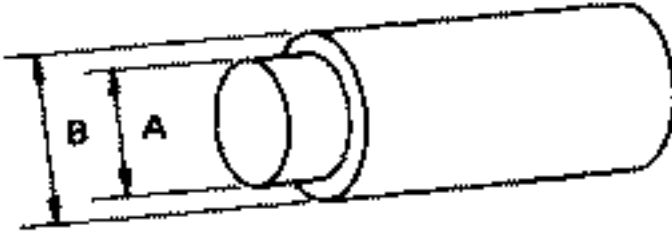
### COMMERCIAL SERVICE TOOLS

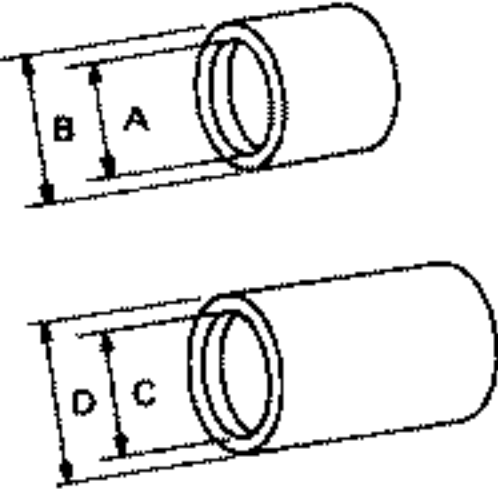
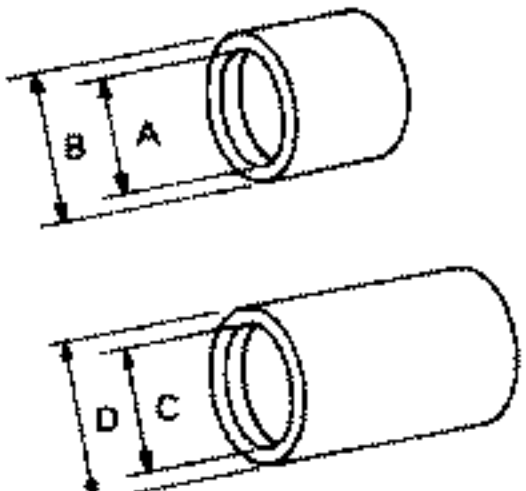
Tool name	Description
Rear wheel hub drift	 <p data-bbox="1433 291 1800 407">Installing wheel bearing            A: 41 mm (1.61 in) dia.            B: 49 mm (1.93 in) dia.</p>
Wheel bearing drift	 <p data-bbox="1433 544 1821 661">Removing rear wheel hub            A: 26 mm (1.02 in) dia.            B: 40 mm (1.57 in) dia.</p>
Rear drive shaft plug seal drift	 <p data-bbox="1433 794 1961 911">Installing rear drive shaft plug seal            A: 67 mm (2.64 in) dia.            B: 85 mm (3.35 in) dia.</p>
Rear axle housing ball joint drift	 <p data-bbox="1433 1042 1811 1246">Removing ball joint            A: 20 (0.79) dia.            B: 28 (1.10) dia.            C: 40 (1.57) dia.            D: 43 (1.69) dia.            Unit: mm (in)</p>
Rear axle housing ball joint drift	 <p data-bbox="1433 1505 1811 1709">Installing ball joint            A: 33 (1.30) dia.            B: 43 (1.69) dia.            C: 30 (1.18) dia.            D: 40 (1.57) dia.            Unit: mm (in)</p>

# REAR AXLE AND REAR SUSPENSION

Final tightening for rubber parts must be done under unladen condition\*, with tires on ground.

\* Fuel, radiator coolant and engine oil full.

Spare tire, jack, hand tools and mats in designated positions.

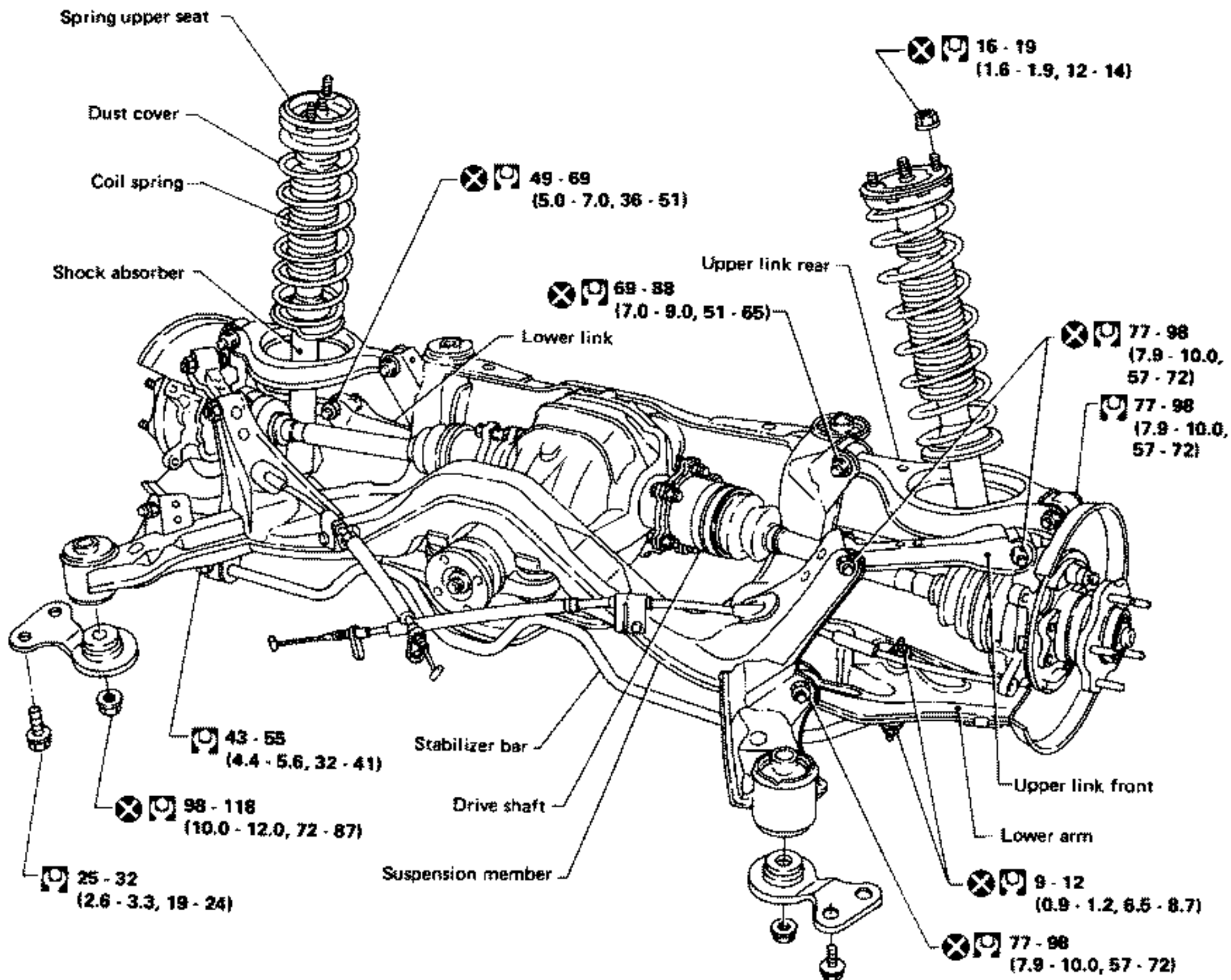

: N.m (kg-m, ft-lb)

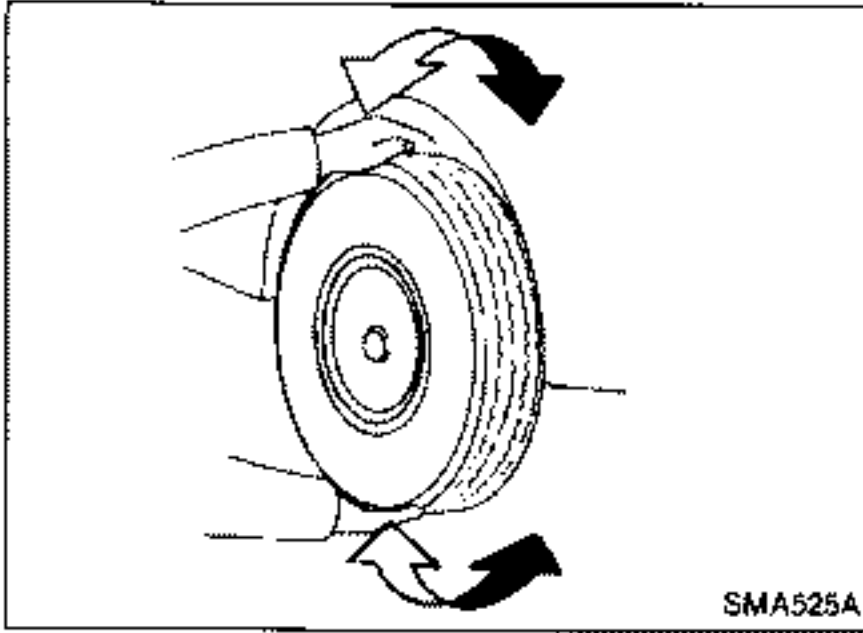

## Rear Axle and Rear Suspension Parts

Check axle and suspension parts for looseness, wear or damage.

- Shake each rear wheel to check for excessive play.

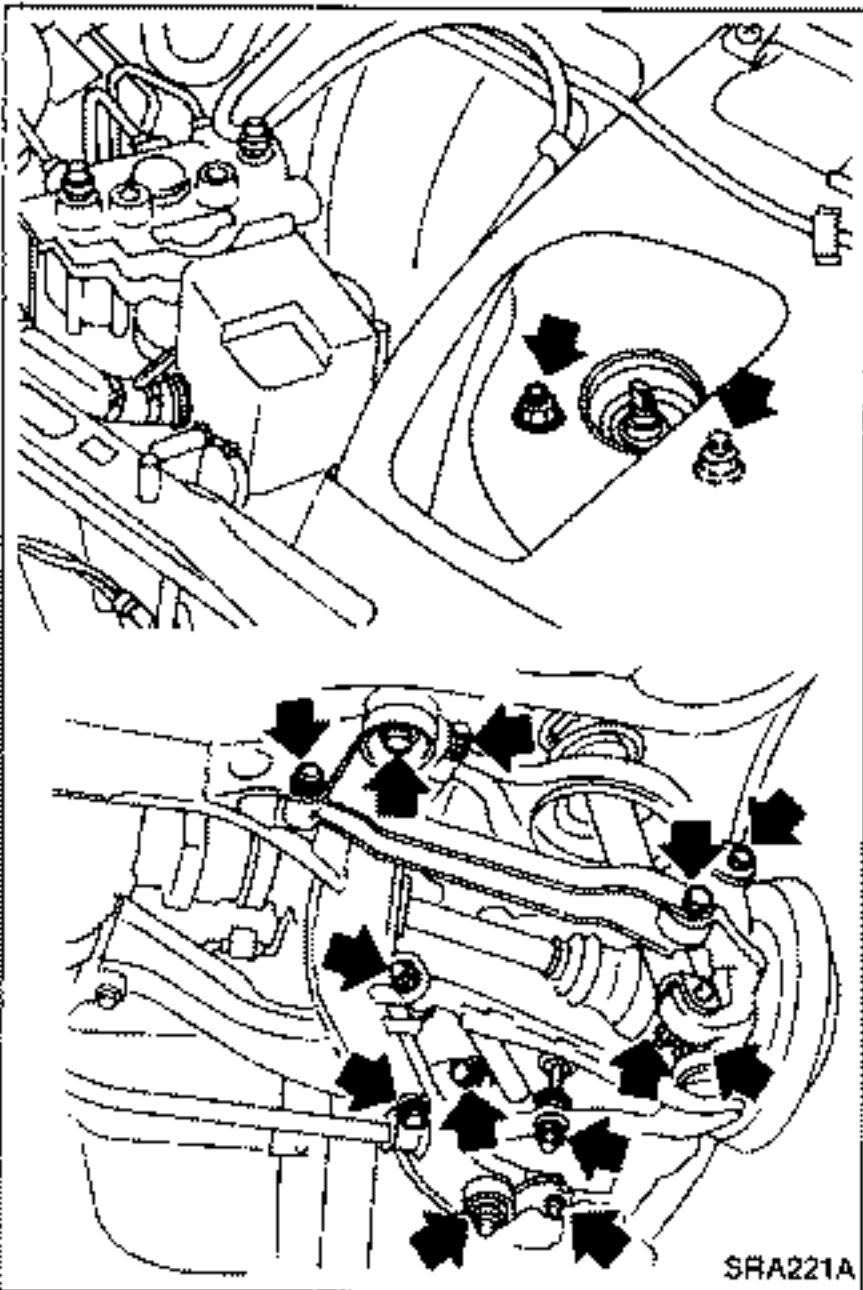

- Retighten all nuts and bolts to the specified torque.  
**Tightening torque:**  
**Refer to REAR SUSPENSION.**
- Make sure that cotter pin is inserted.

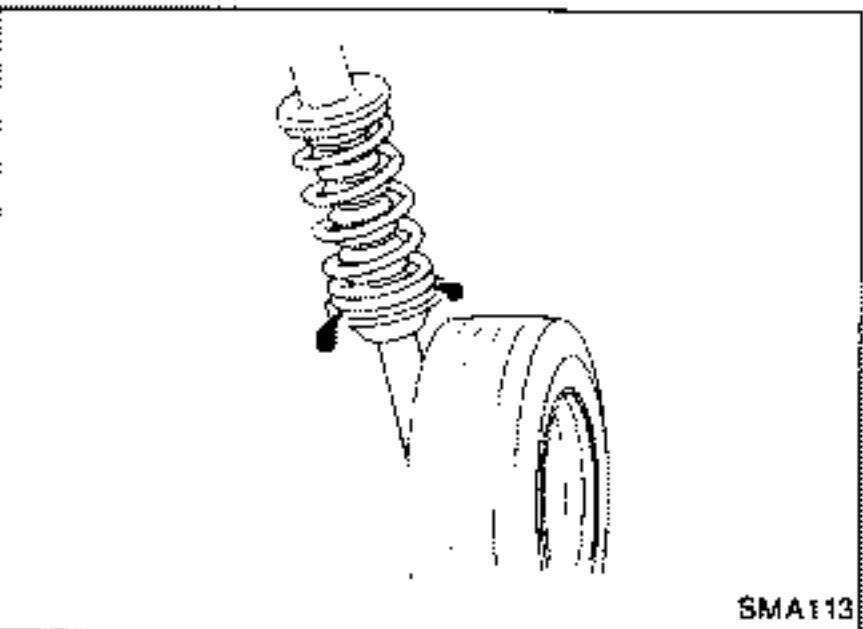

- Check shock absorber for oil leakage or other damage.

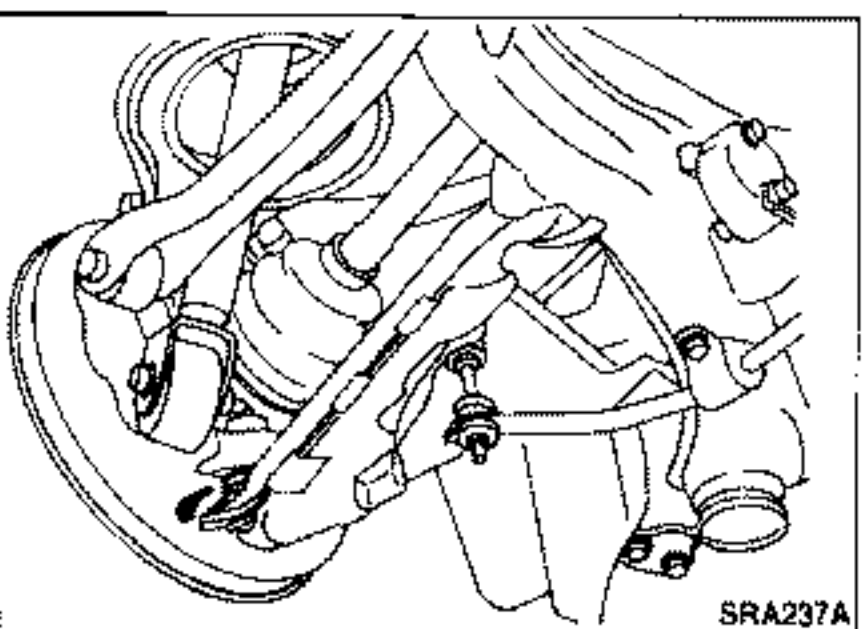

- Check suspension ball joint for grease leakage and ball joint dust cover for cracks or other damage.

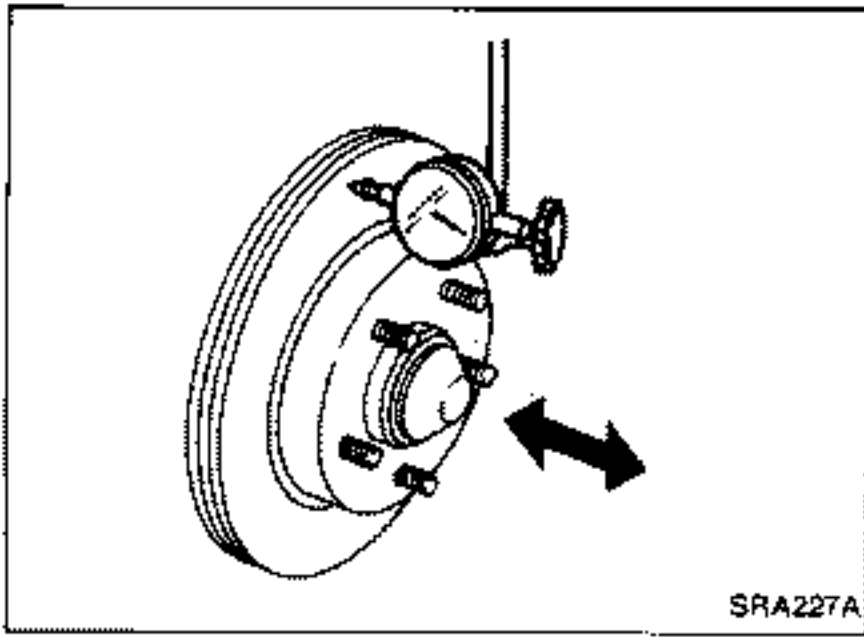

## Rear Wheel Bearing

- Check wheel bearings for smooth operation.
- Check axial end play.

### Axial end play:

**0.05 mm (0.0020 in) or less**

If axial end play is not within specification or wheel bearing does not turn smoothly, replace wheel bearing assembly. Refer to REAR AXLE — Wheel Hub and Axle Housing.

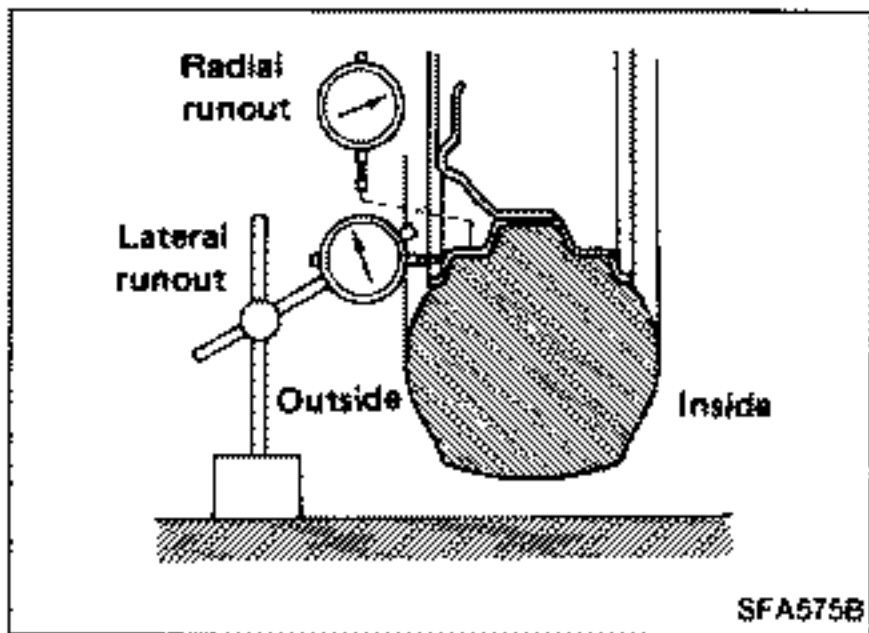

## Rear Wheel Alignment

Before checking rear wheel alignment, be sure to make a preliminary inspection.

### PRELIMINARY INSPECTION

Make the following checks. Adjust, repair or replace if necessary.

- Check tires for wear and for improper inflation.
- Check rear wheel bearings for looseness.
- Check wheel runout.

### Wheel runout:

**Refer to S.D.S. in section FA.**

- Check that rear shock absorber works properly.
- Check rear axle and rear suspension parts for looseness.
- Check vehicle posture (Unladen).  
("Unladen": Fuel, radiator coolant and engine oil full. Spare tire, jack, hand tools and mats in designated positions.)

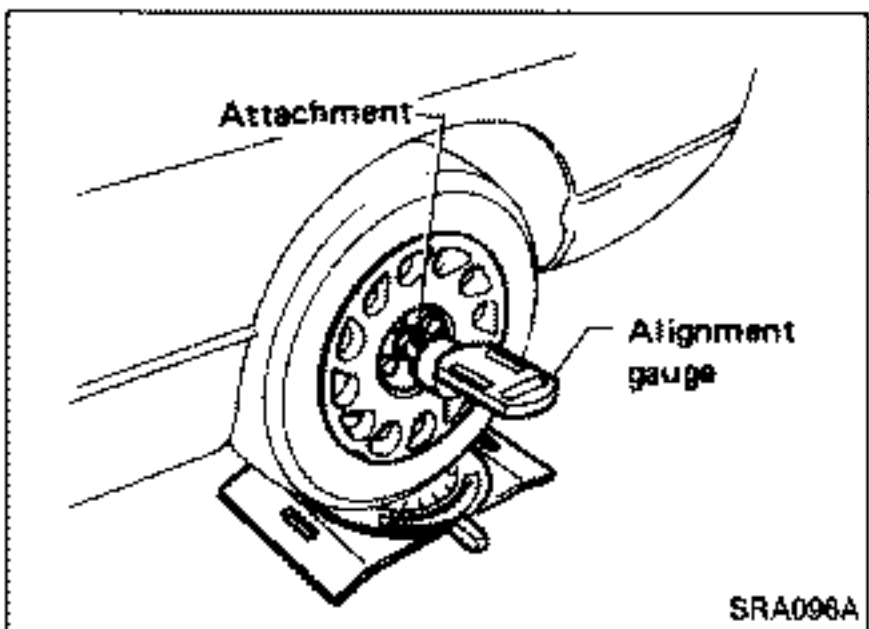

## CAMBER

- Measure camber of both right and left wheels with a suitable alignment gauge and adjust in accordance with the following procedures.

### Camber:

**-1°35' to -0°35'**

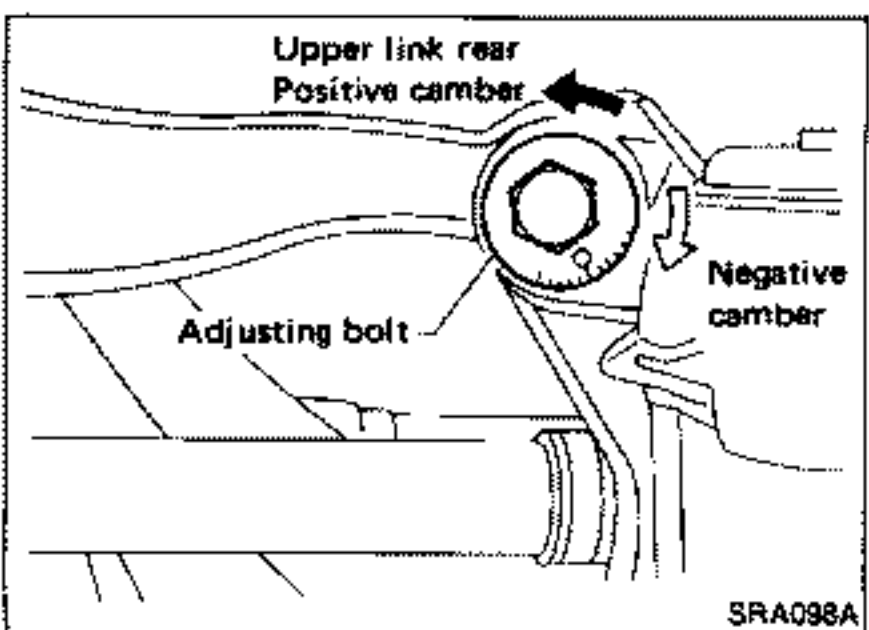

If camber is not within specification, adjust by turning the adjusting pin.

- (1) Turn the adjusting pin to adjust.

**Camber changes about 5' with each graduation of the adjusting pin.**

- (2) Tighten to the specified torque.

**⌘: 69 - 88 N·m**

**(7.0 - 9.0 kg-m, 51 - 65 ft-lb)**

## Rear Wheel Alignment (Cont'd)

### TOE-IN

1. Draw a base line across the tread.
  - After lowering rear of vehicle, move it up and down to eliminate friction.

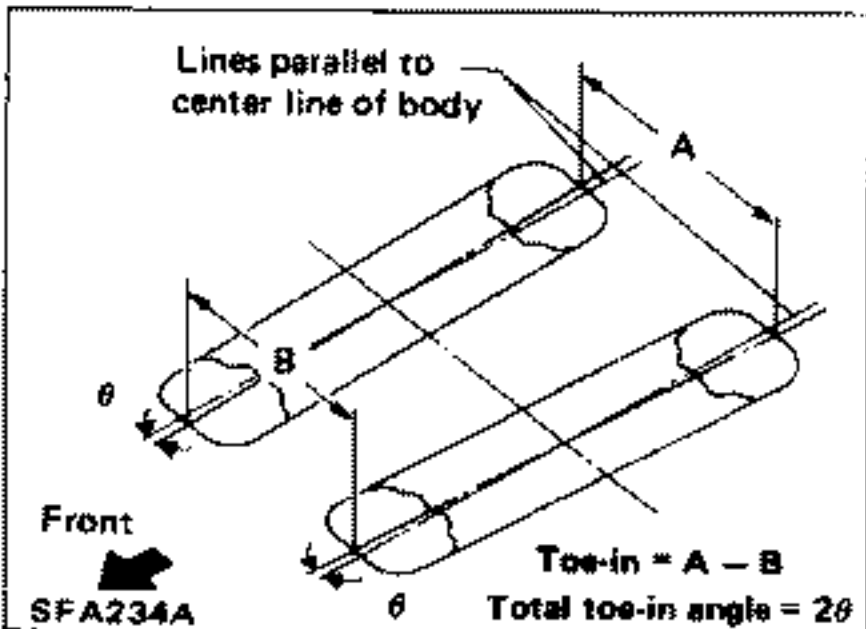
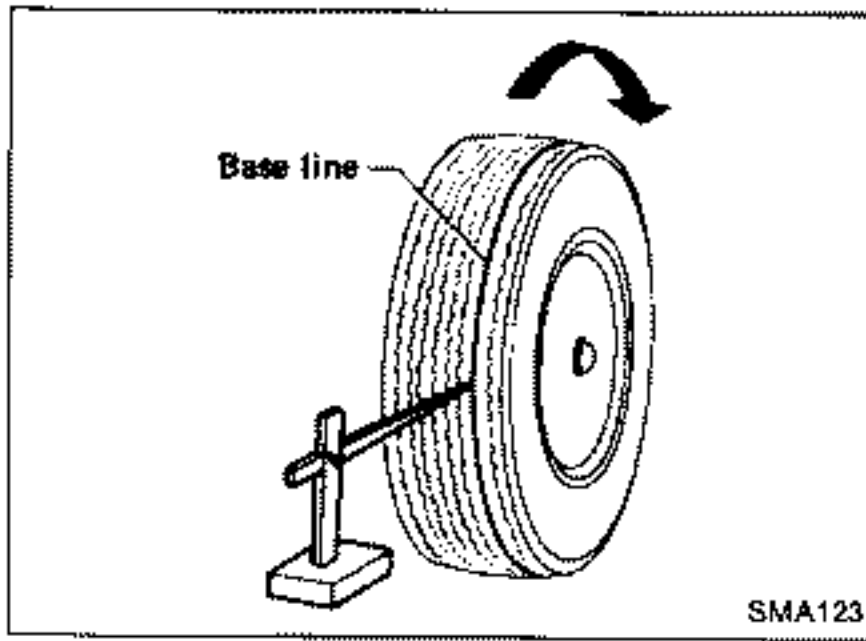

2. Measure toe-in.
  - Measure distance "A" and "B" at the same height as hub center.

#### Total toe-in:

A - B: 0 - 4 mm (0 - 0.16 in)

2θ: 0' - 22'

3. Adjust toe-in by turning adjusting pins.

**Toe changes about 1.5 mm (0.059 in) [One side] with each graduation of the adjusting pin.**

4. Tighten to the specified torque.

[C]: 69 - 88 N·m

(7.0 - 9.0 kg-m, 51 - 65 ft-lb)

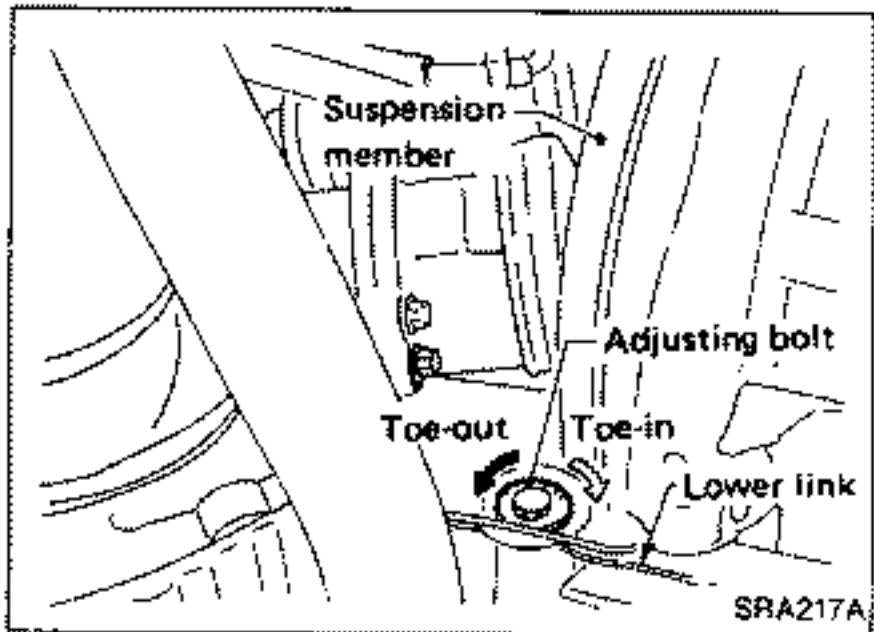

### Drive Shaft

Check boot and drive shaft for cracks, wear, damage or grease leakage.

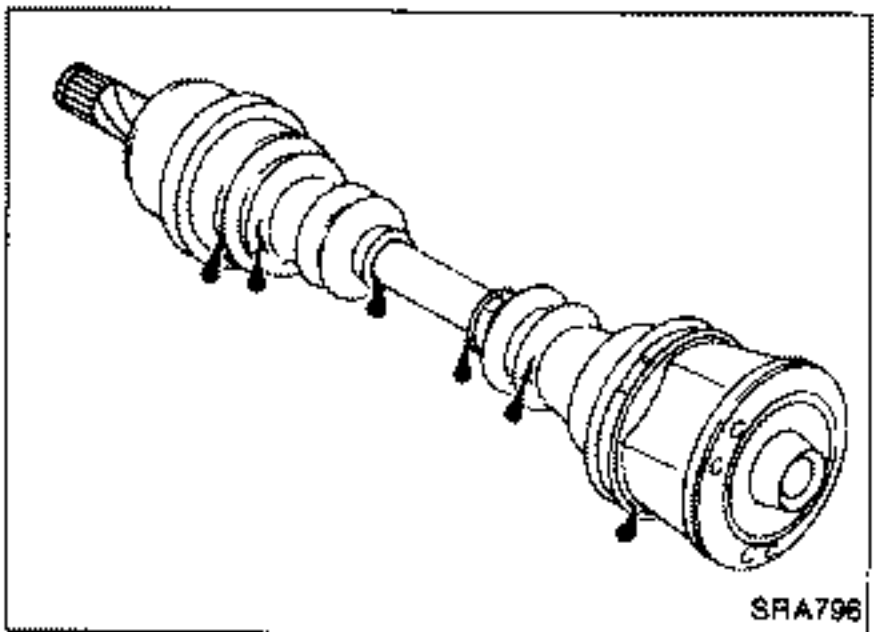

# REAR AXLE — Wheel Hub and Axle Housing

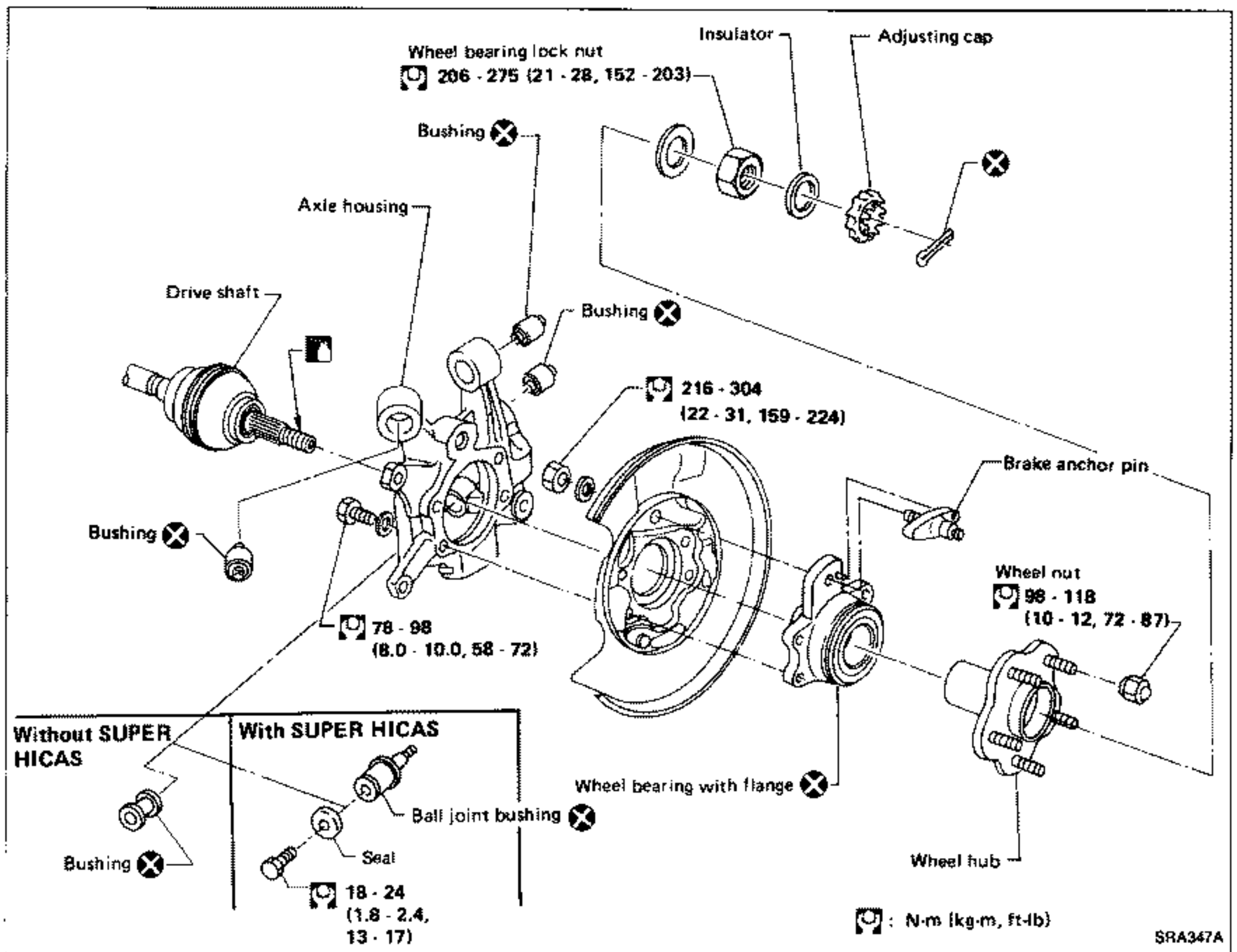

## Removal

- Remove wheel bearing lock nut.

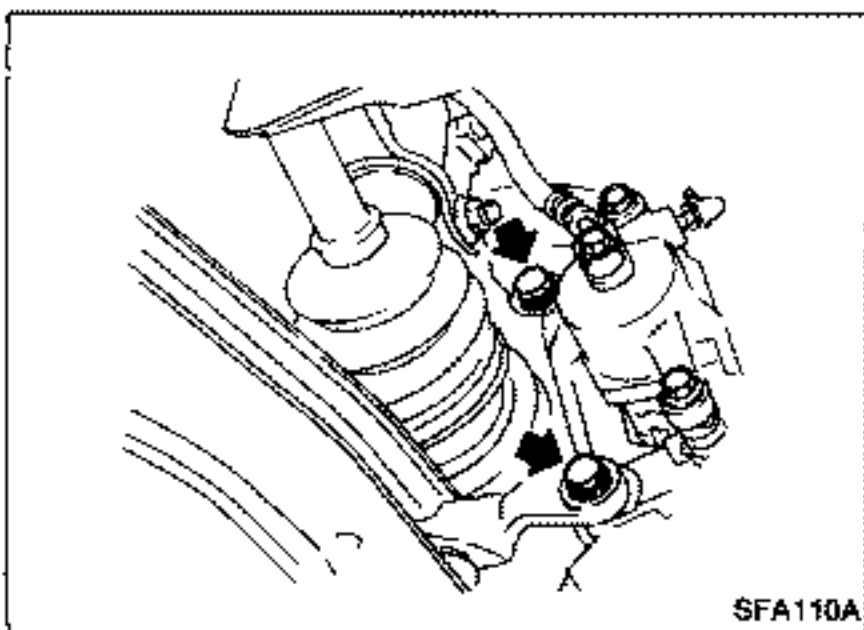

- Remove brake caliper assembly and rotor. **Brake line need not be disconnected from brake caliper. Be careful not to depress brake pedal, or piston will pop out. Do not pull or twist brake hose.**



## Removal (Cont'd)

- Separate drive shaft from axle housing by slightly tapping it. If it is hard to separate, them, use a puller.

**When removing drive shaft, cover boots with waste cloth to prevent them from being damaged.**

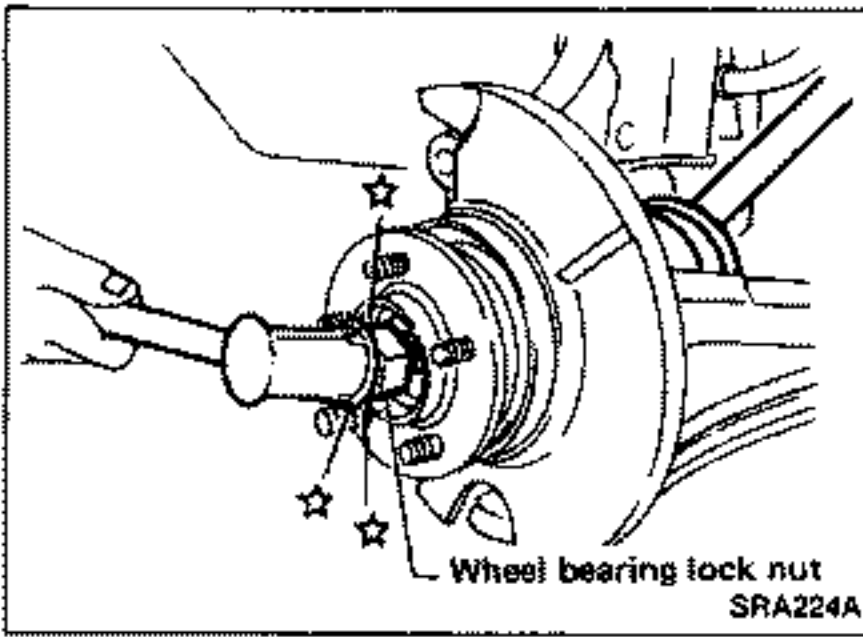

- Remove axle housing.

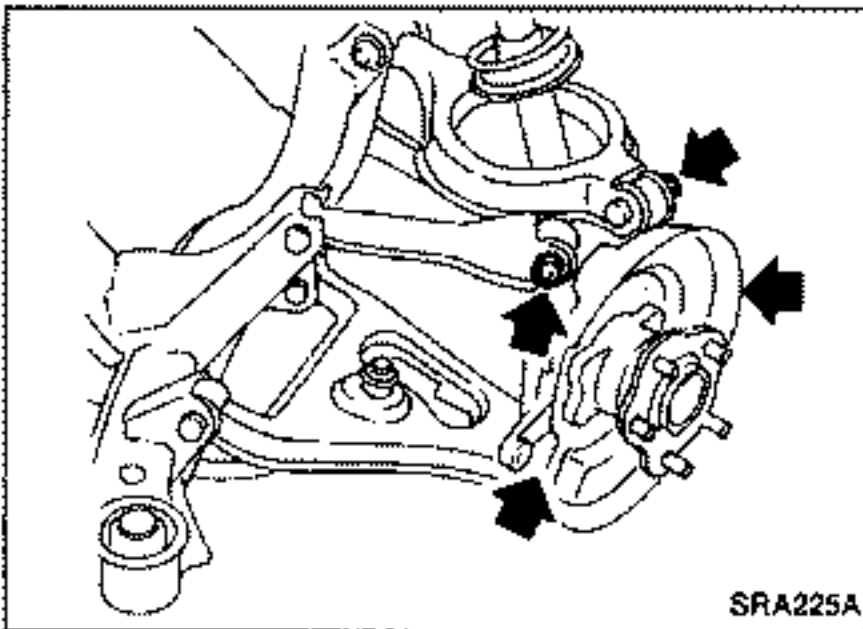

- Remove wheel bearing with flange, and wheel hub from axle housing.

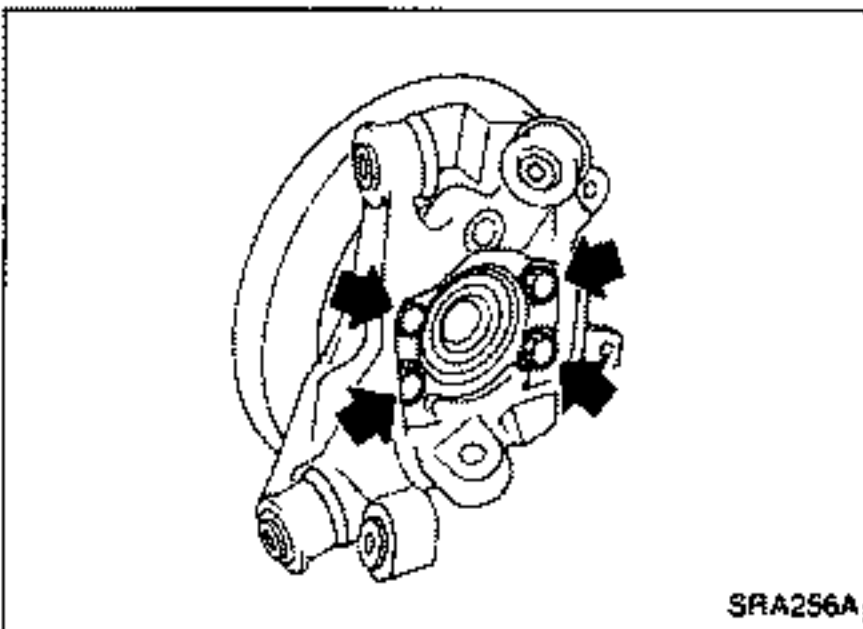

## Installation

- Install axle housing with wheel hub.
- Tighten wheel bearing lock nut.  
⌚: 206 - 275 N·m  
(21 - 28 kg-m, 152 - 203 ft-lb)

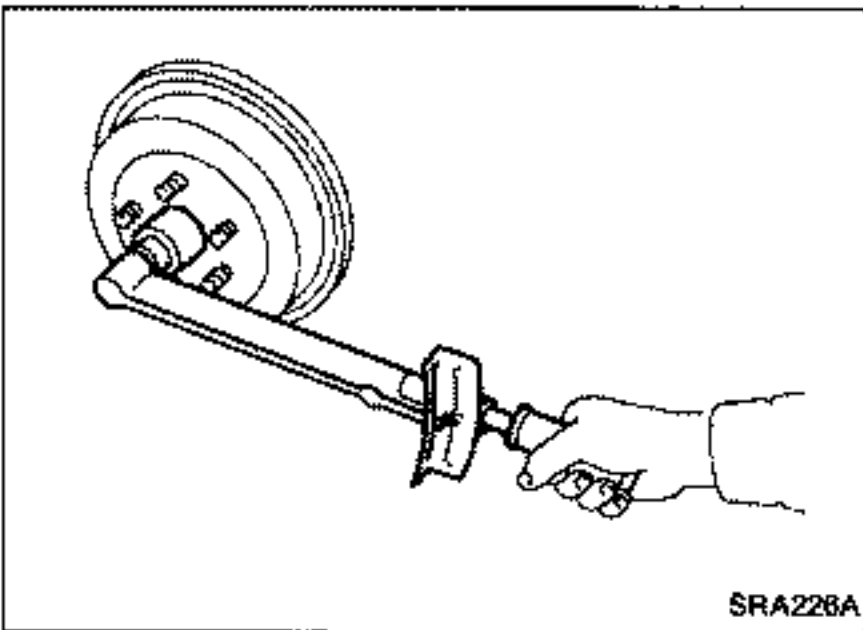

- Check wheel bearing axial end play.  
**Axial end play: 0.05 mm (0.0020 in) or less**

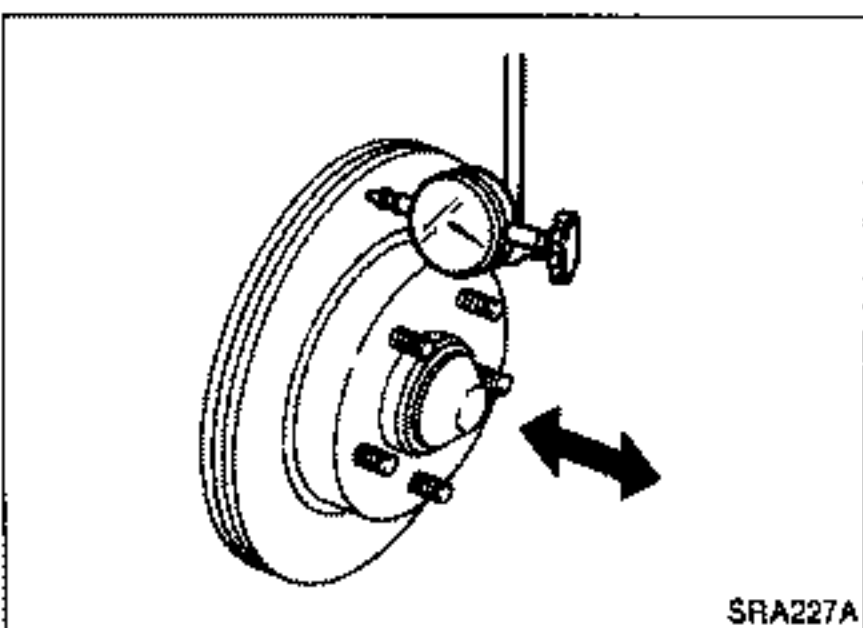

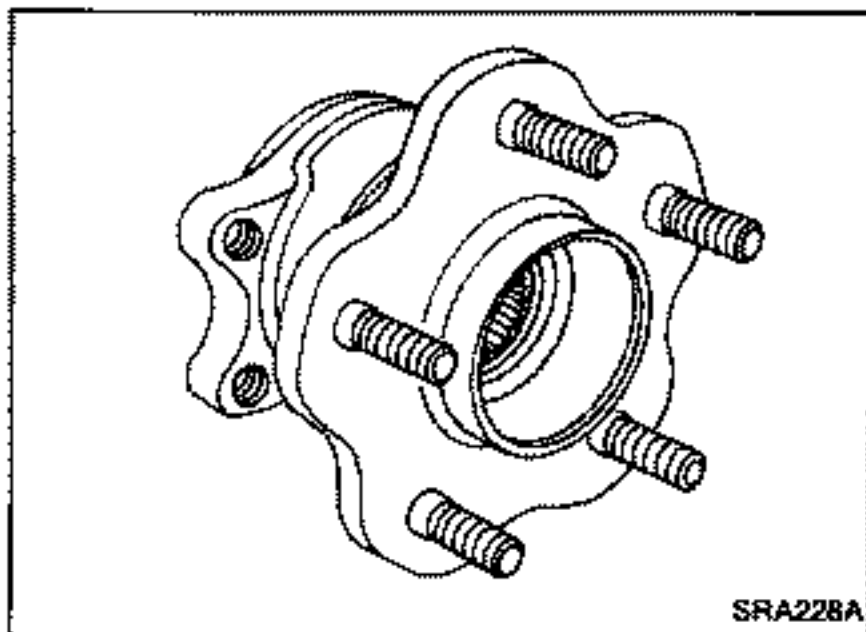

## Disassembly

### CAUTION:

Wheel bearing with flange usually does not require maintenance. If any of the following symptoms are noted, replace wheel bearing assembly (including flange, and inner and outer seals).

- Growling noise is emitted from wheel bearing during operation.
- Wheel bearing drags or turns roughly when hub is turned with your hand after bearing lock nut is tightened to specified torque.
- After wheel bearing is removed from hub.

## WHEEL HUB

Remove wheel bearing (with flange) and wheel hub as one unit from axle housing before disassembling.

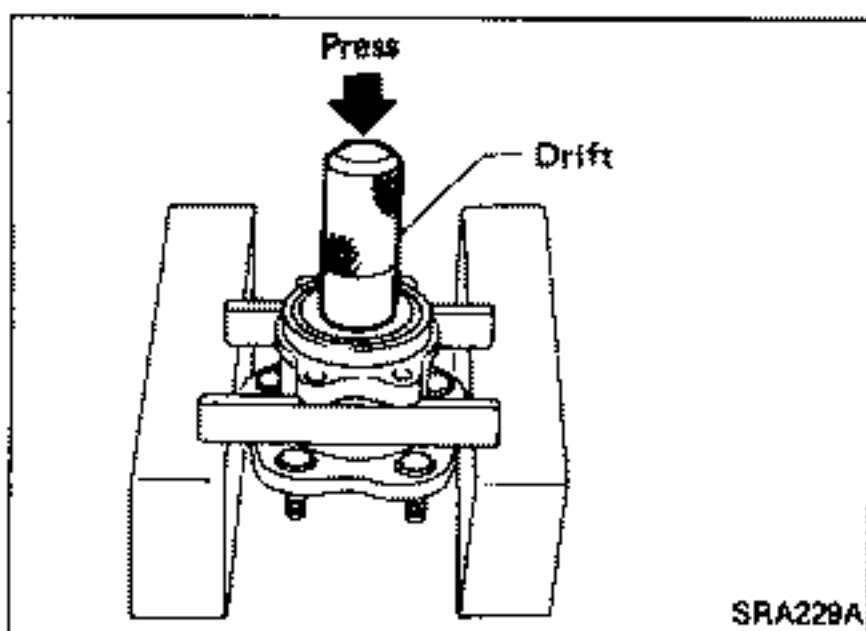

## WHEEL BEARING

- Using a press and drift as shown in figure at left, press wheel bearing out.
- Discard old wheel bearing assembly. Replace with a new wheel assembly.

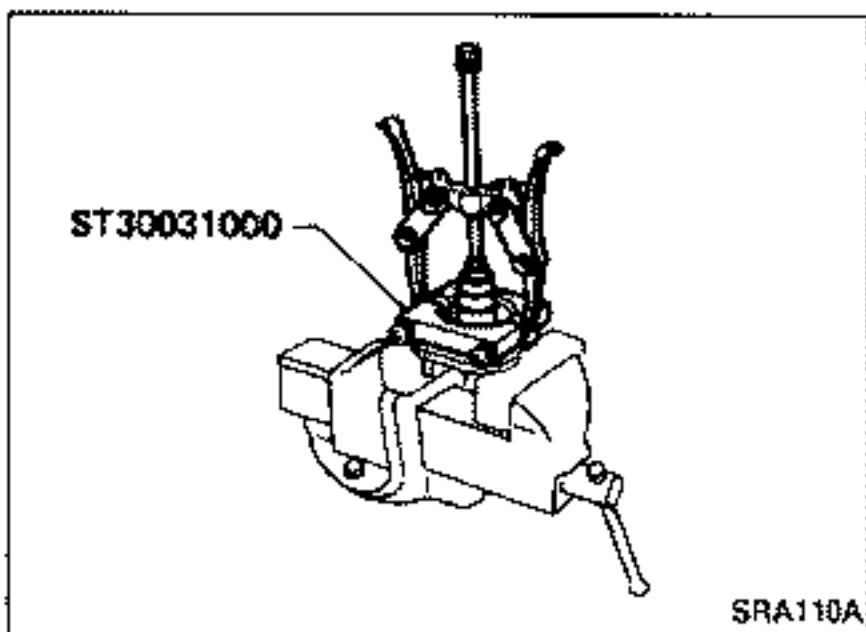

- Remove inner race from hub using a bearing replacer /puller.

### CAUTION:

- Do not reuse old inner race although it is of the same brand as the bearing assembly.
- Do not replace grease seals as single parts.

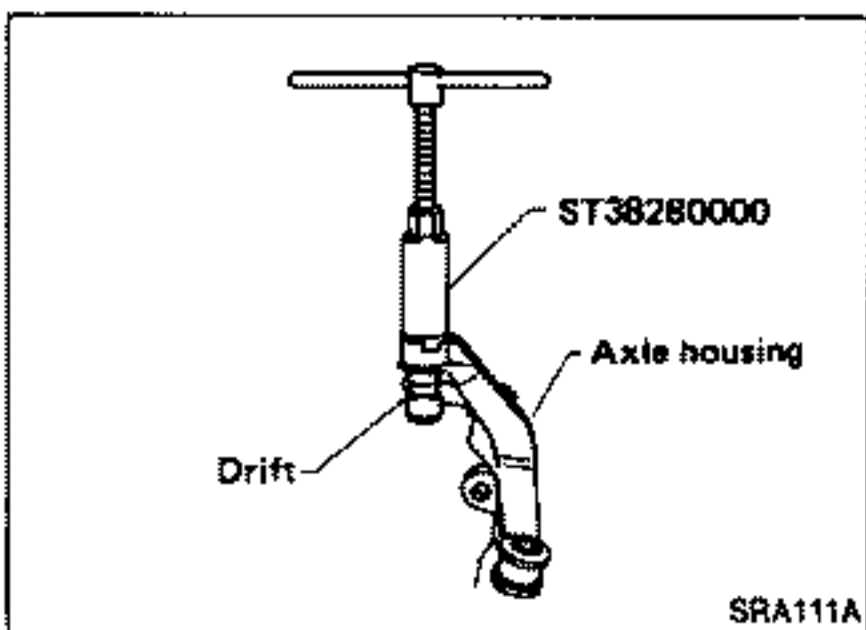

## AXLE HOUSING

- Attach a drift on outer shell of bushing as shown in figure at left, remove bushing using arm bushing remover.

When placing axle housing in a vise, use wooden blocks or copper plates as pads.

## Disassembly (Cont'd)

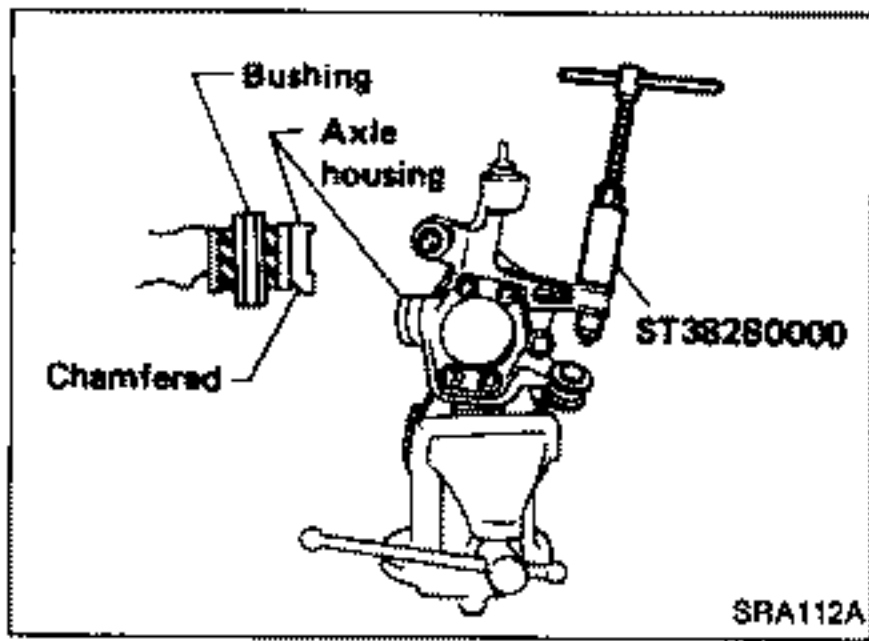

- Ensure axle housing bore is free from scratches or deformities before pressing bushing into it.
- Attach bushing to chamfered bore end of axle housing and press it until it is flush with end face of axle housing.

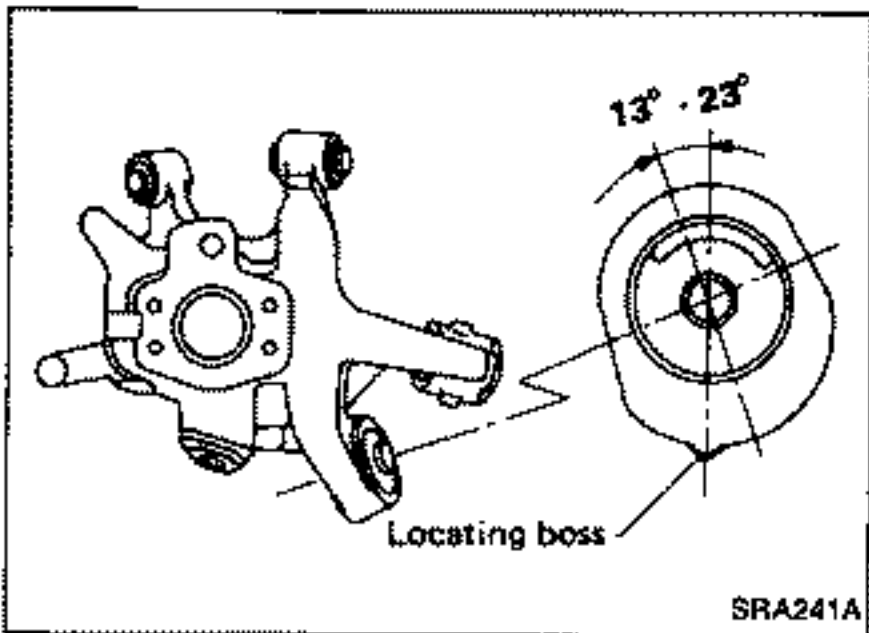

- When installing shock absorber bushing, make sure that it is positioned as shown.

## Inspection

### WHEEL HUB AND AXLE HOUSING

- Check wheel hub and axle housing for cracks by using a magnetic exploration or dyeing test.
- Check wheel bearing for damage, seizure, rust or rough operation.
- Check rubber bushing for wear or other damage.

**Replace if necessary.**

## Assembly

Place hub on a block. Attach a drift to inner race of wheel bearing and press it into hub as shown in figure at left.

**Be careful not to damage grease seal.**

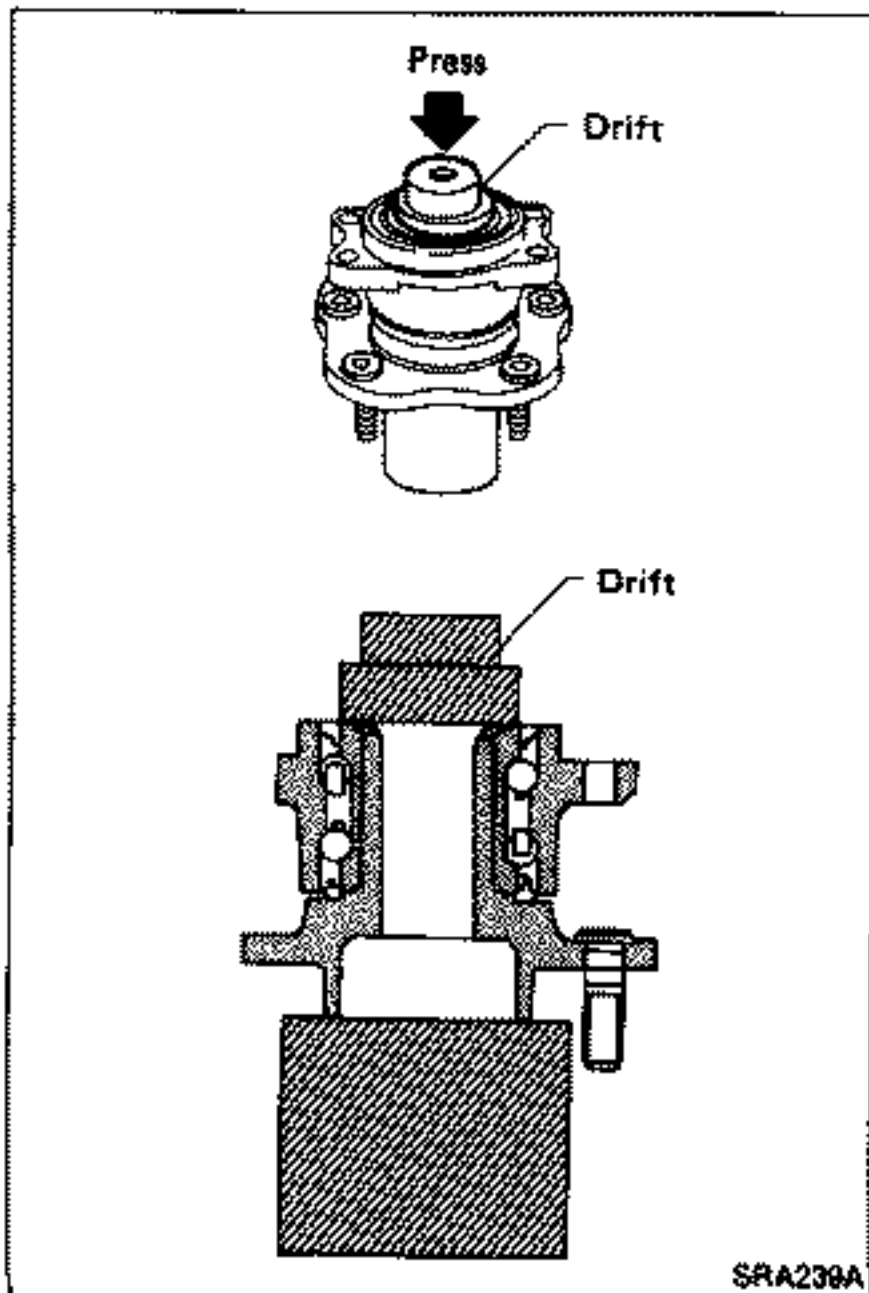

# REAR AXLE — Drive Shaft

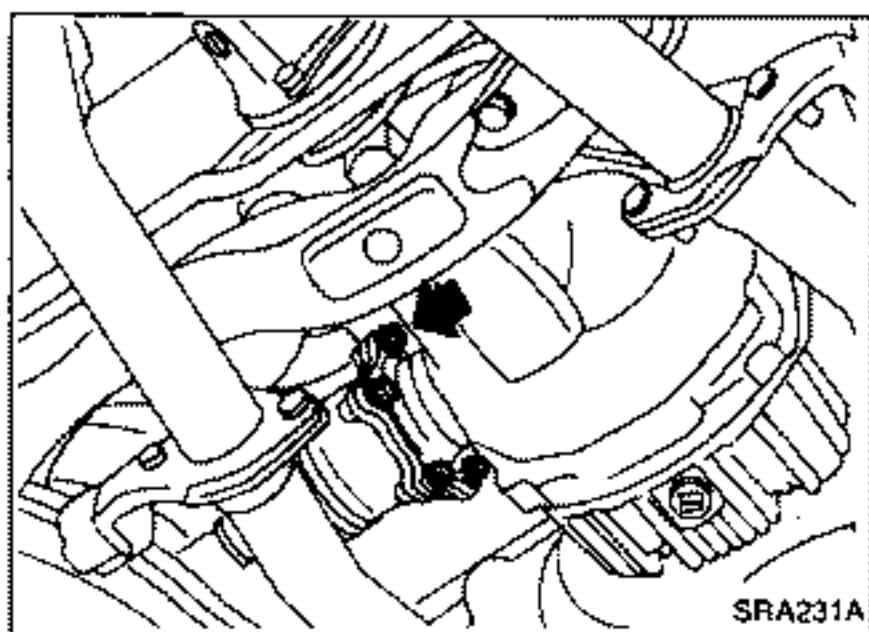
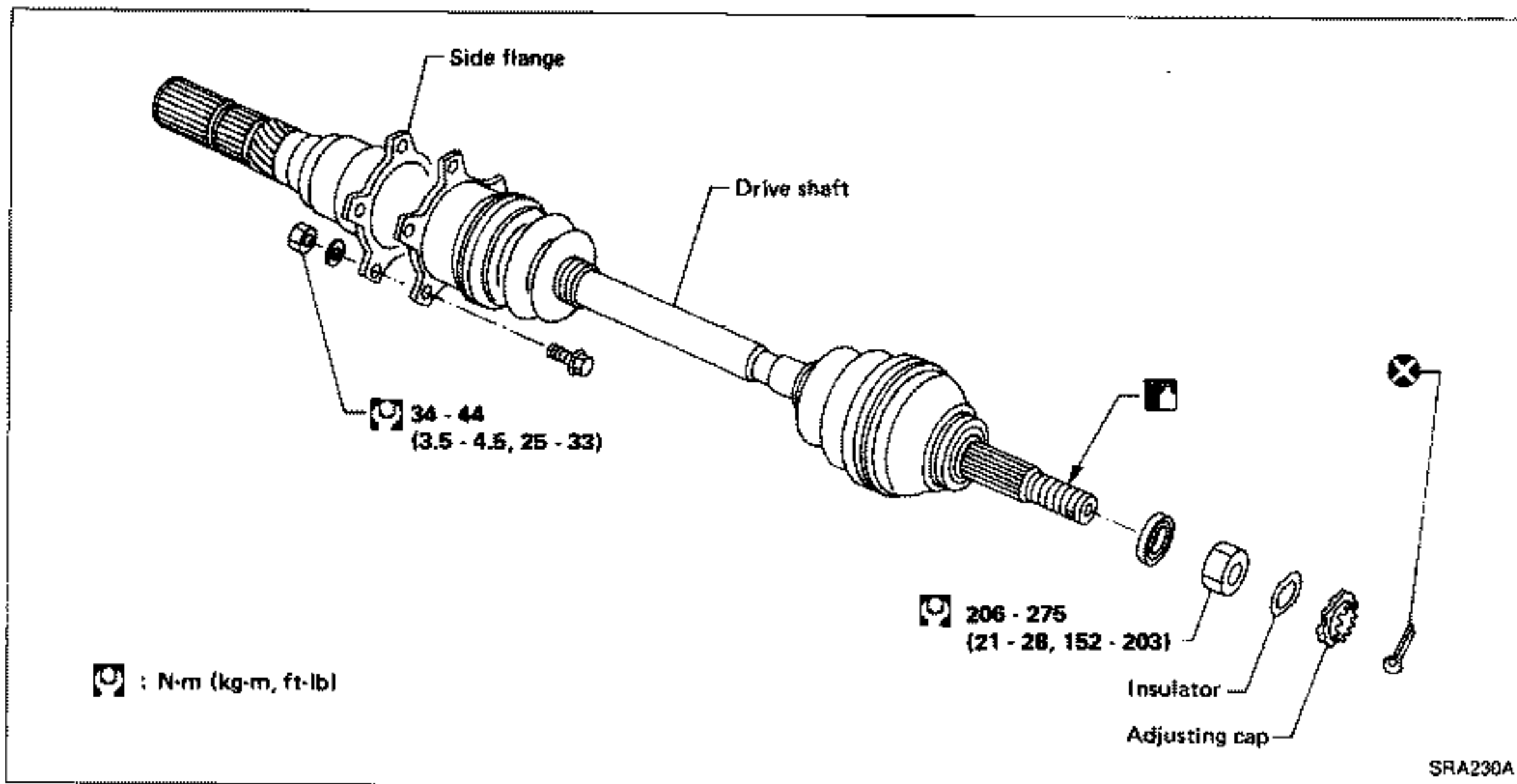

## Removal

When removing drive shaft, cover boots with waste cloth to prevent damage to them.

### FINAL DRIVE SIDE

Remove side flange mounting bolt and separate shaft.

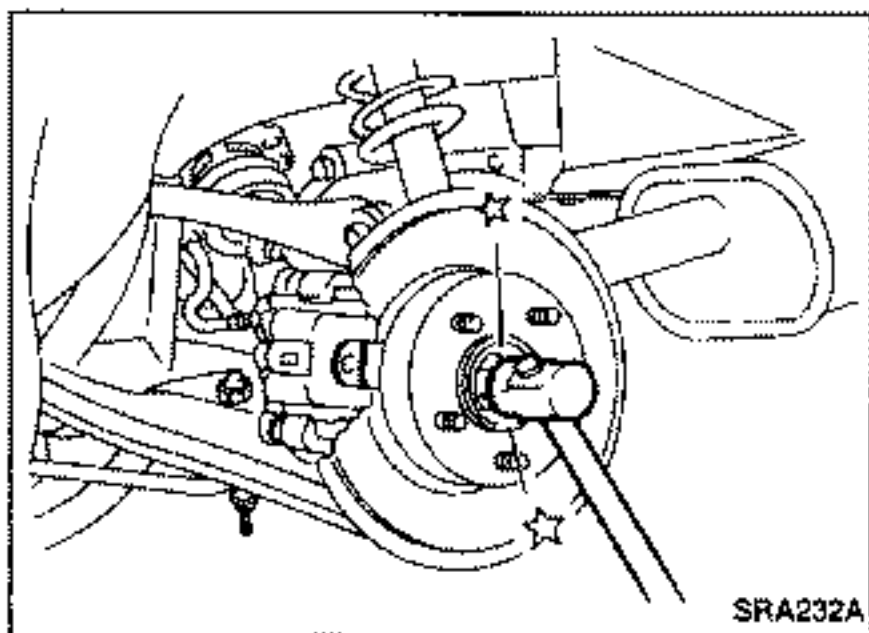

### WHEEL SIDE

Remove drive shaft by lightly tapping it with a copper hammer. To avoid damaging threads of drive shaft, install a nut while removing drive shaft.

## Installation

- Insert drive shaft from wheel hub and temporarily tighten wheel bearing lock nut.
- Tighten side flange mounting bolts to specified torque.
- Tighten wheel bearing lock nut to specified torque.

## Components

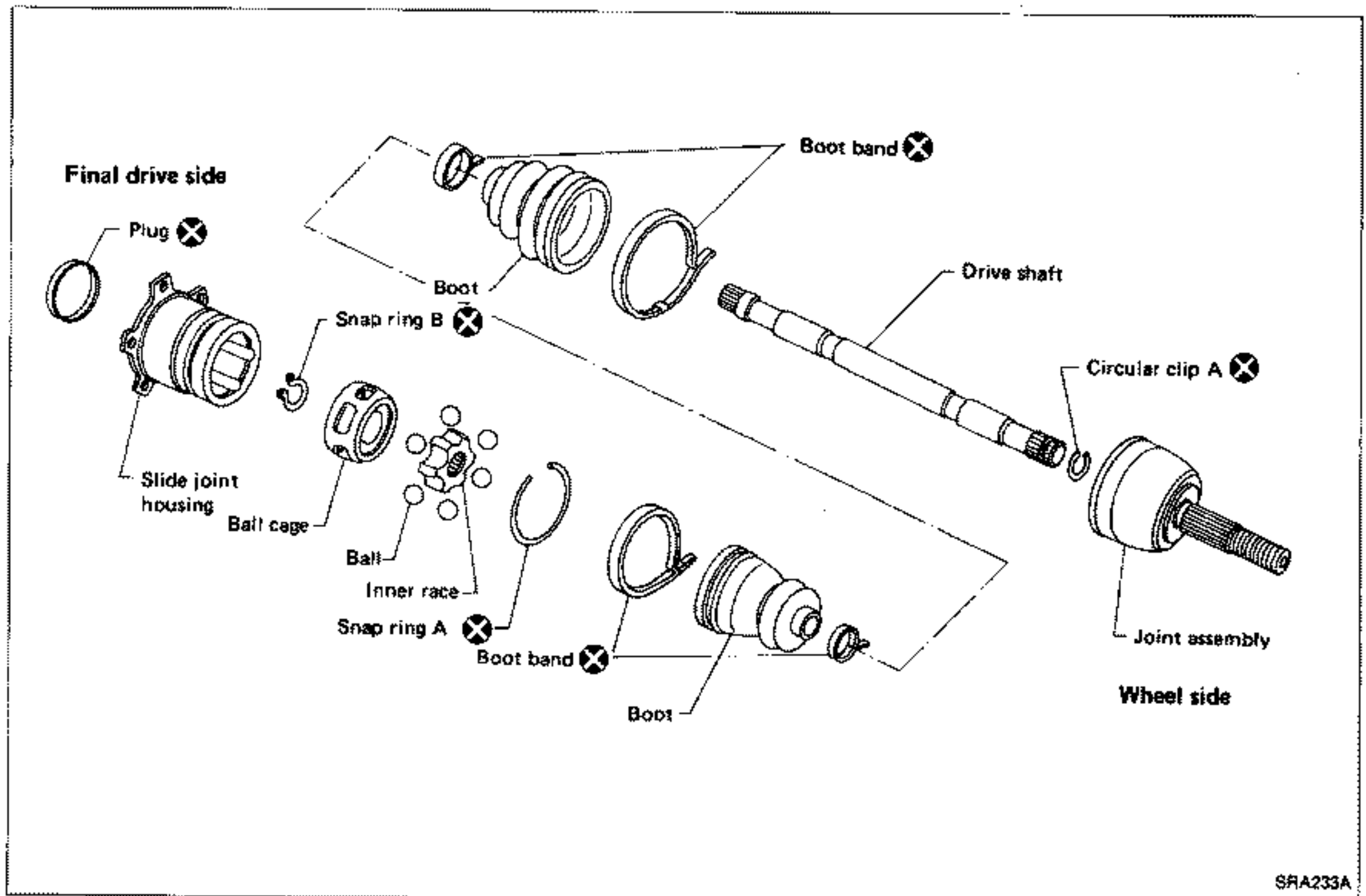

SRA233A

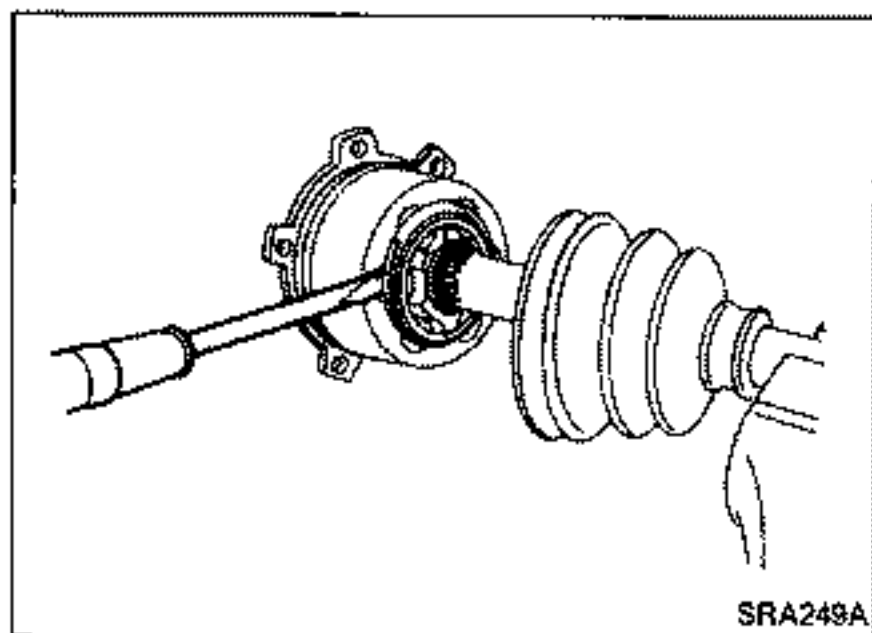

SRA249A

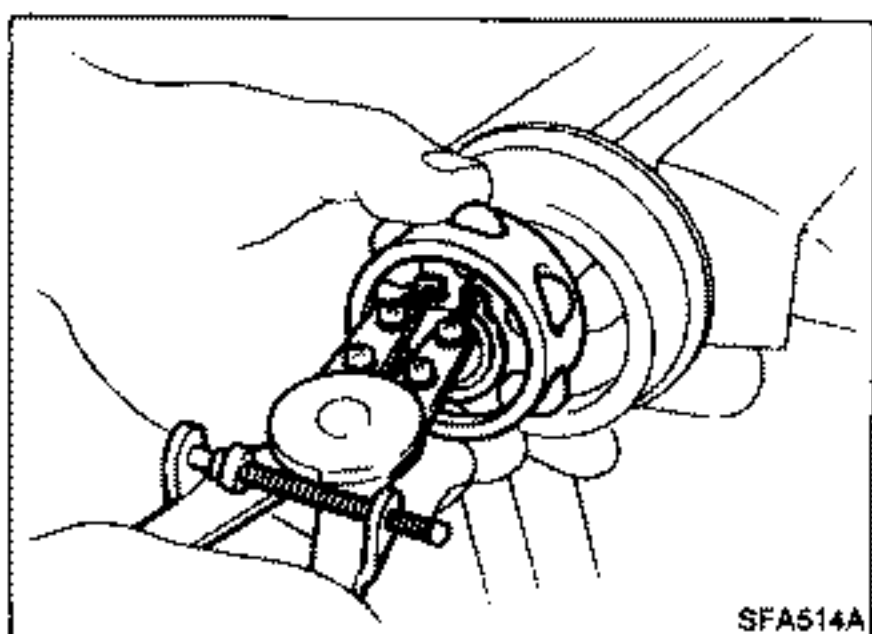

SFA514A

## Disassembly

### FINAL DRIVE SIDE (DS90, DS100)

1. Remove boot bands.
2. Put matching marks on slide joint housing and inner race, before separating joint assembly.
3. Pry off snap ring "A" with a screwdriver, and pull out slide joint housing.

4. Put matching marks on inner race and drive shaft.
5. Pry off snap ring "B", then remove ball cage, inner race and balls as a unit.
6. Draw out boot.

**Cover drive shaft serration with tape so as not to damage the boot.**

## REAR AXLE — Drive Shaft

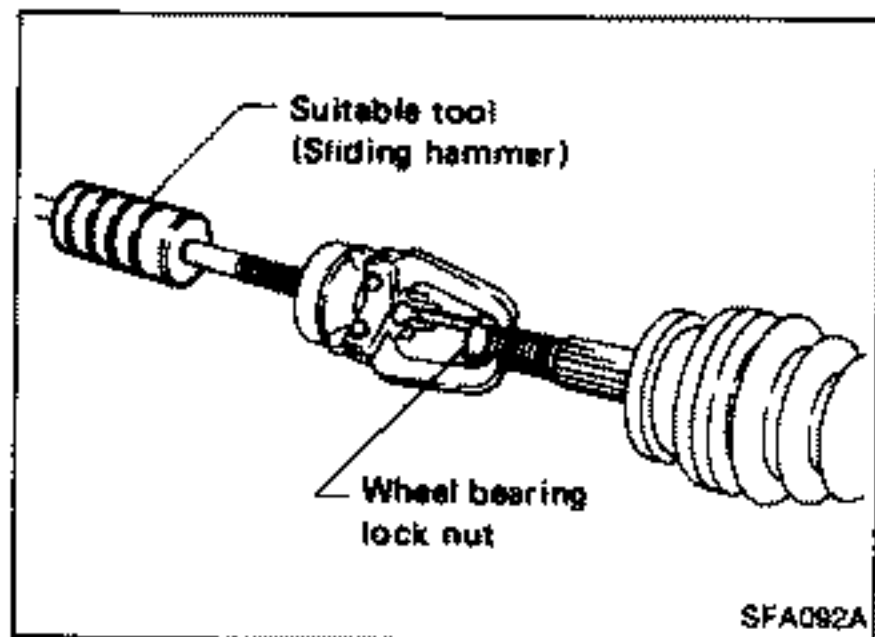

### Disassembly (Cont'd)

#### WHEEL SIDE (ZF100, BF100)

##### CAUTION:

The joint on the wheel side cannot be disassembled.

- Before separating joint assembly, put matching marks on drive shaft and joint assembly.
- Separate joint assembly with a suitable tool.

Be careful not to damage threads on drive shaft.

- Remove boot bands.

### Inspection

Thoroughly clean all parts in cleaning solvent, and dry with compressed air. Check parts for evidence of deformation or other damage.

### DRIVE SHAFT

Replace drive shaft if it is twisted or cracked.

### BOOT

Check boot for fatigue, cracks, or wear. Replace boot with new boot bands.

### JOINT ASSEMBLY (Final drive side)

- Replace any parts of double offset joint which show signs of scorching, rust, wear or excessive play.
- Check serration for deformation. Replace if necessary.
- Check slide joint housing for any damage. Replace if necessary.

### JOINT ASSEMBLY (Wheel side)

Replace joint assembly if it is deformed or damaged.

### Assembly

- After drive shaft has been assembled, ensure that it moves smoothly over its entire range without binding.
- Use NISSAN GENUINE GREASE or equivalent after every overhaul.

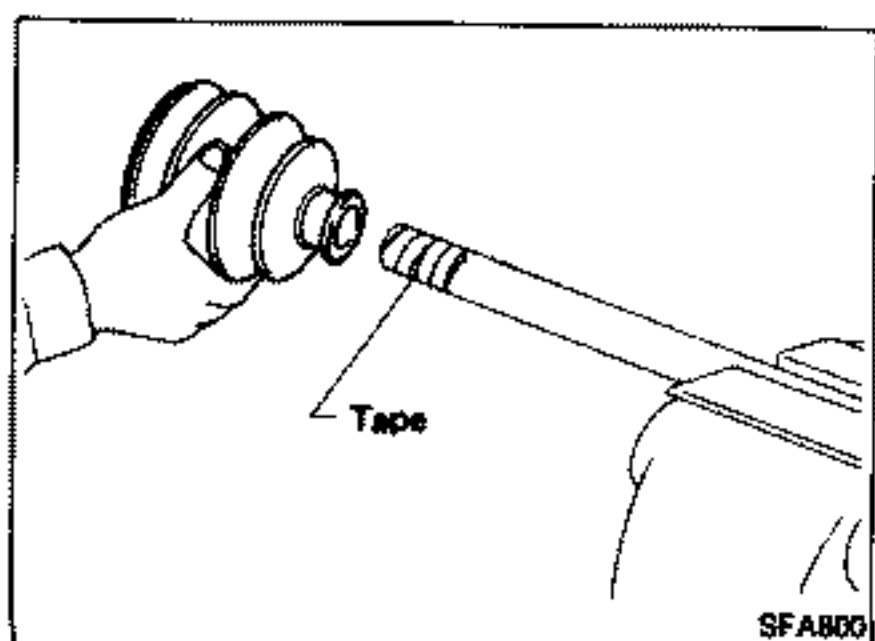

### WHEEL SIDE (ZF100, BF100)

1. Install boot and new small boot band on drive shaft.

Cover drive shaft serration with tape so as not to damage boot during installation.

## REAR AXLE — Drive Shaft

### Assembly (Cont'd)

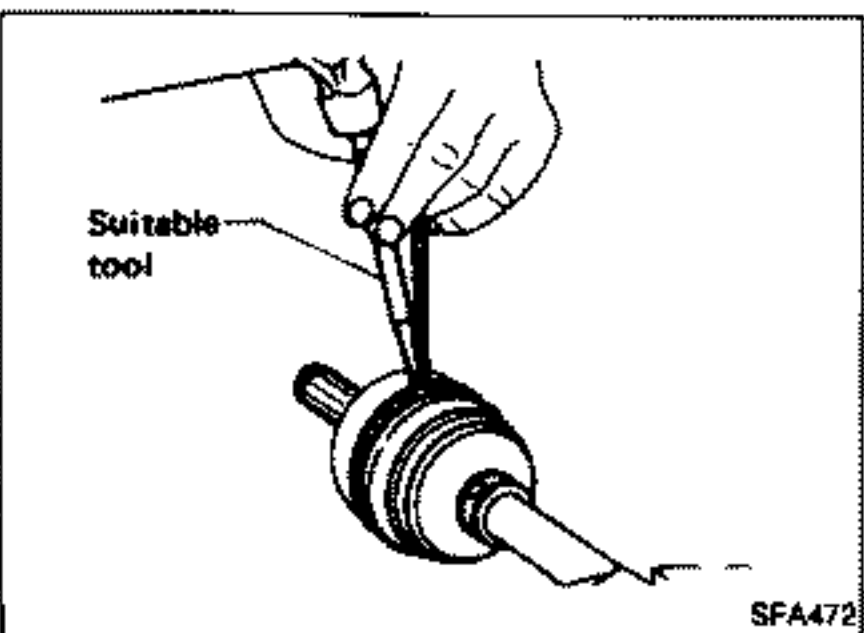
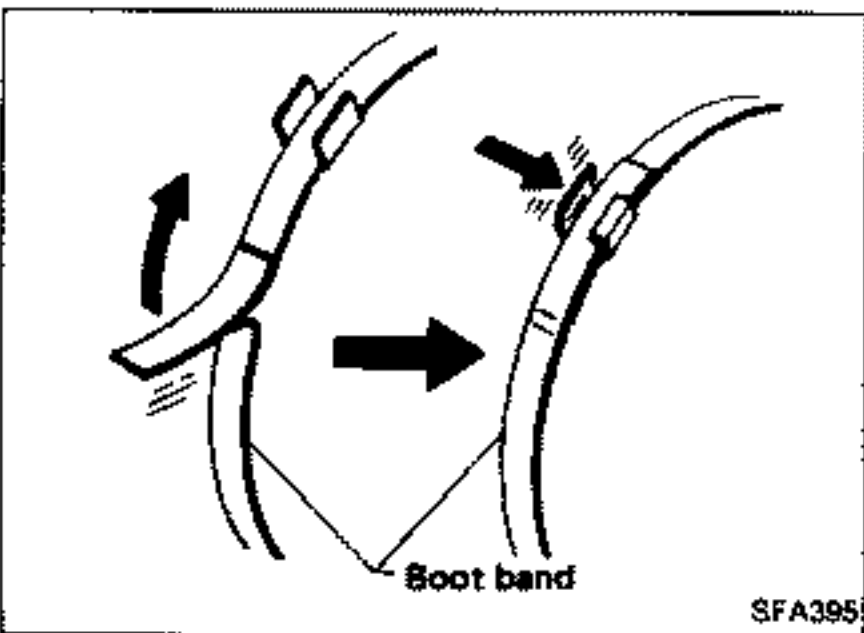
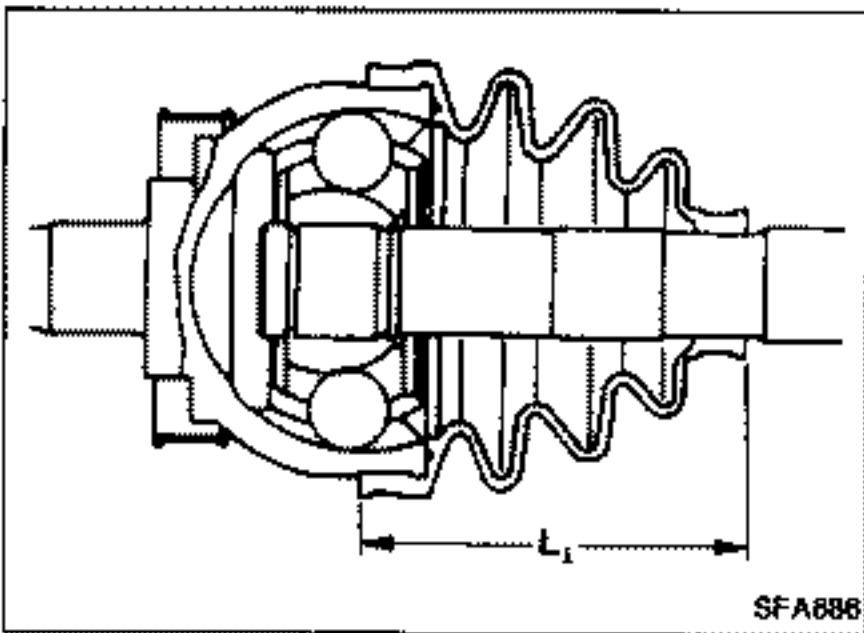
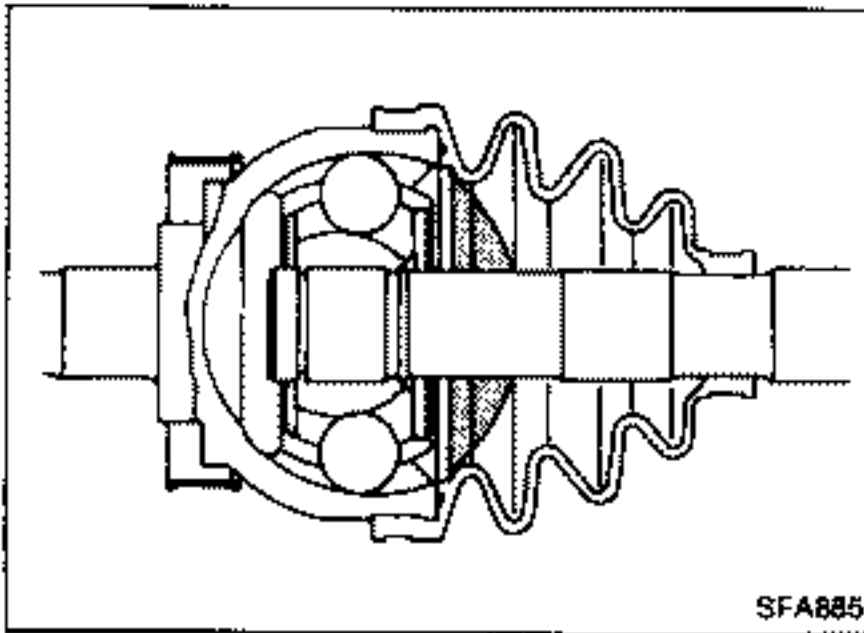
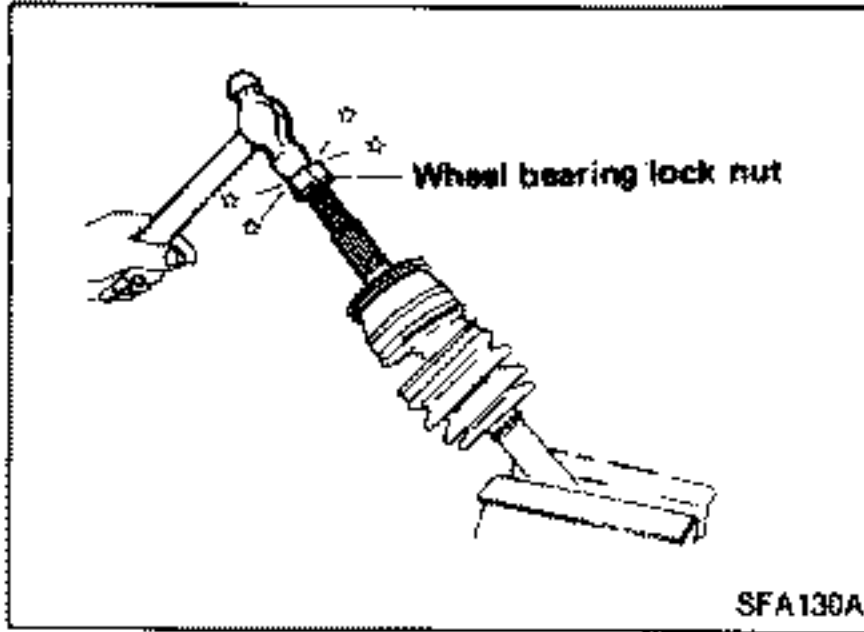

2. Set joint assembly onto drive shaft by lightly tapping it. Install joint assembly securely, ensuring marks which were made during disassembly are properly aligned.

3. Pack drive shaft with specified amount of grease.  
**Specified amount of grease:**

**VG30DE**

165 - 175 g (5.82 - 6.17 oz)

**VG30DETT**

170 - 190 g (6.00 - 6.70 oz)

4. Set boot so that it does not swell and deform when its length is " $L_1$ ".

**Make sure that boot is properly installed on the drive shaft groove.**

**Length " $L_1$ ":**

**VG30DE**

96 - 98 mm (3.78 - 3.86 in)

**VG30DETT**

101 - 103 mm (3.98 - 4.06 in)

5. Lock new larger and smaller boot bands securely with a suitable tool.

## Assembly (Cont'd)

### FINAL DRIVE SIDE (DS90, DS100)

1. Install boot and new small boot band on drive shaft.  
**Cover drive shaft serration with tape so as not to damage boot during installation.**

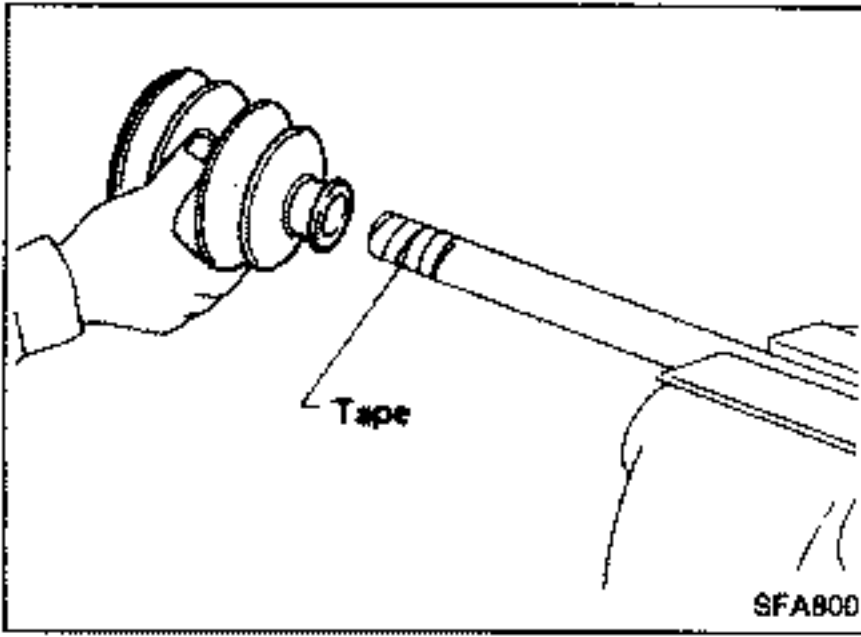

2. Securely install ball cage, inner race and balls as a unit, making sure the marks which were made during disassembly are properly aligned.
3. Install new snap ring "B".

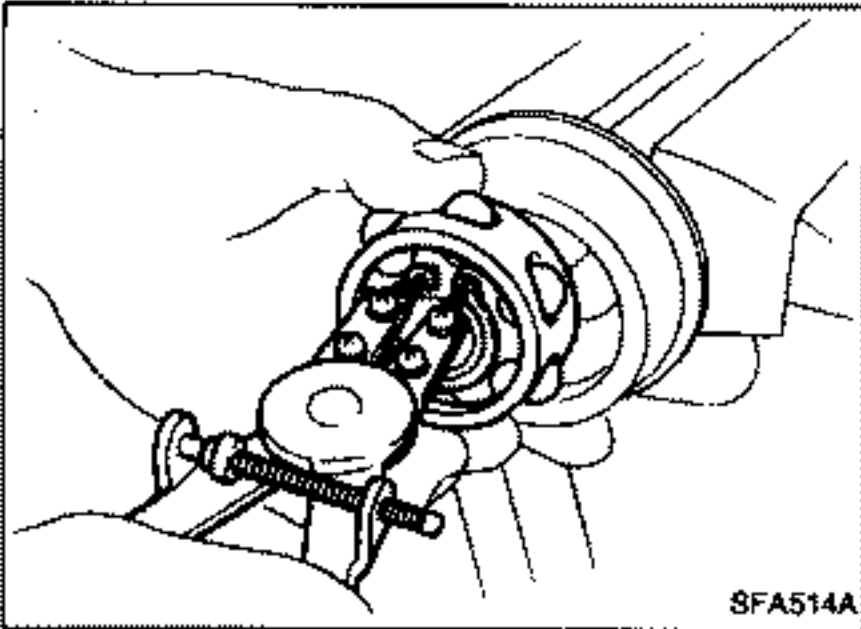

4. Pack drive shaft with specified amount of grease.

**Specified amount of grease:**

**VG30DE**

**165 - 175 g (5.82 - 6.17 oz)**

**VG30DETT**

**180 - 200 g (6.35 - 7.05 oz)**

5. Install slide joint housing, then install new snap ring "A".
6. Set boot so that it does not swell and deform when its length is "L<sub>2</sub>".

**Make sure that boot is properly installed on the drive shaft groove.**

**Length "L<sub>2</sub>":**

**VG30DE**

**93 - 95 mm (3.66 - 3.74 in)**

**VG30DETT**

**102.5 - 104.5 mm (4.04 - 4.11 in)**

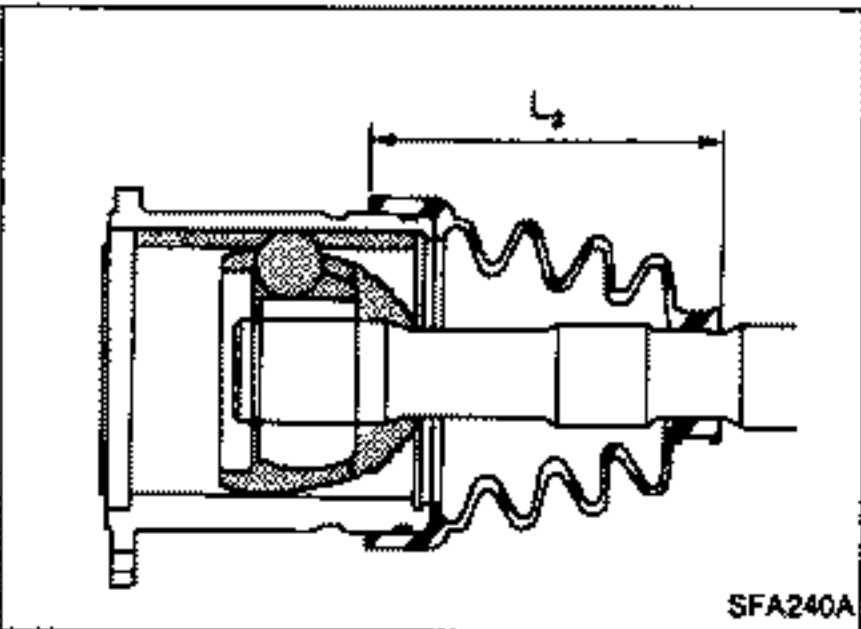

7. Lock new larger and smaller boot bands securely with a suitable tool.

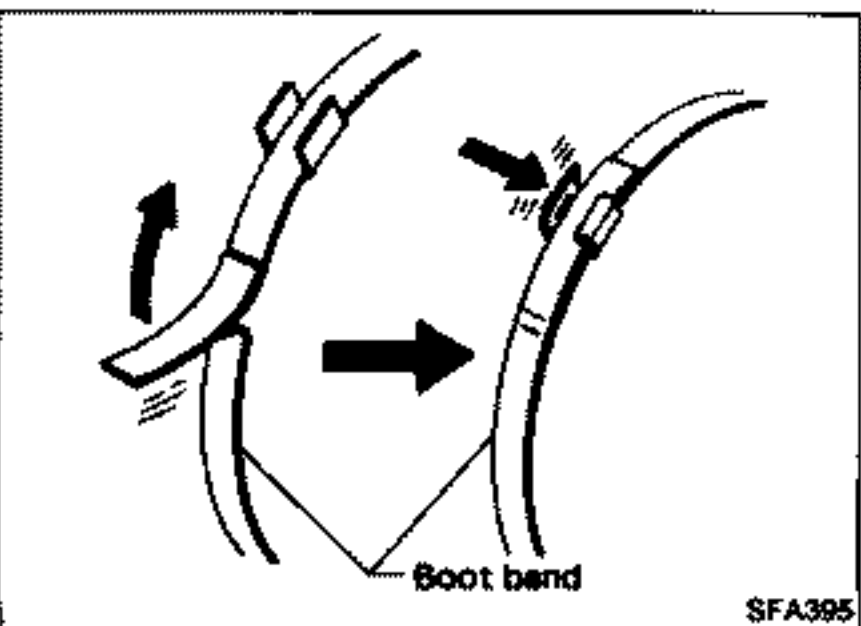



# REAR SUSPENSION

## CAUTION:

Do not jack up at lower arm.

Final tightening for rubber parts must be done under unladen condition\*, with tires on ground.

\* Fuel, radiator coolant and engine oil full.

Spare tire, jack, hand tools and mats in designated positions.

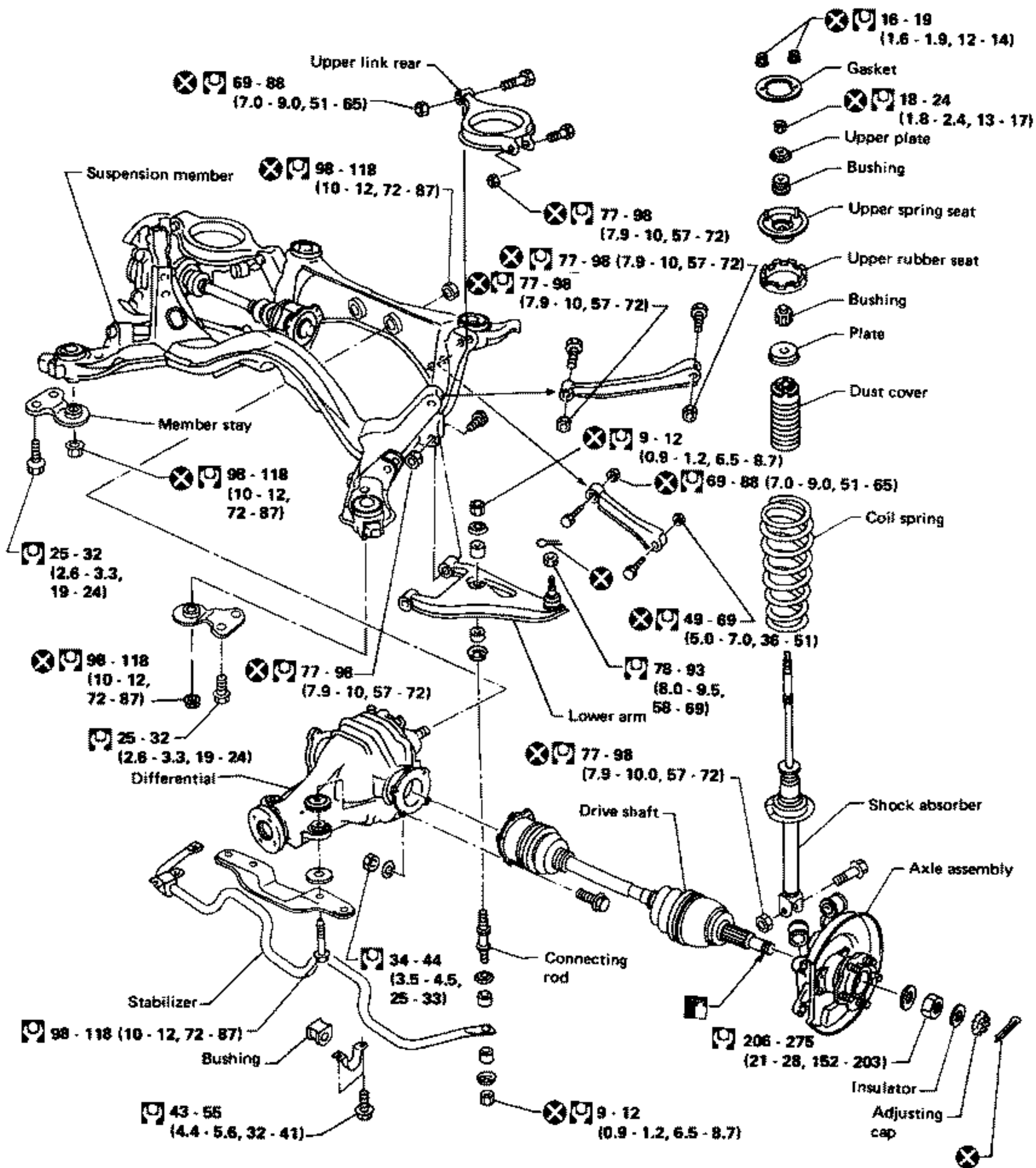

: N-m (kg-m, ft-lb)

# REAR SUSPENSION

## Removal and Installation

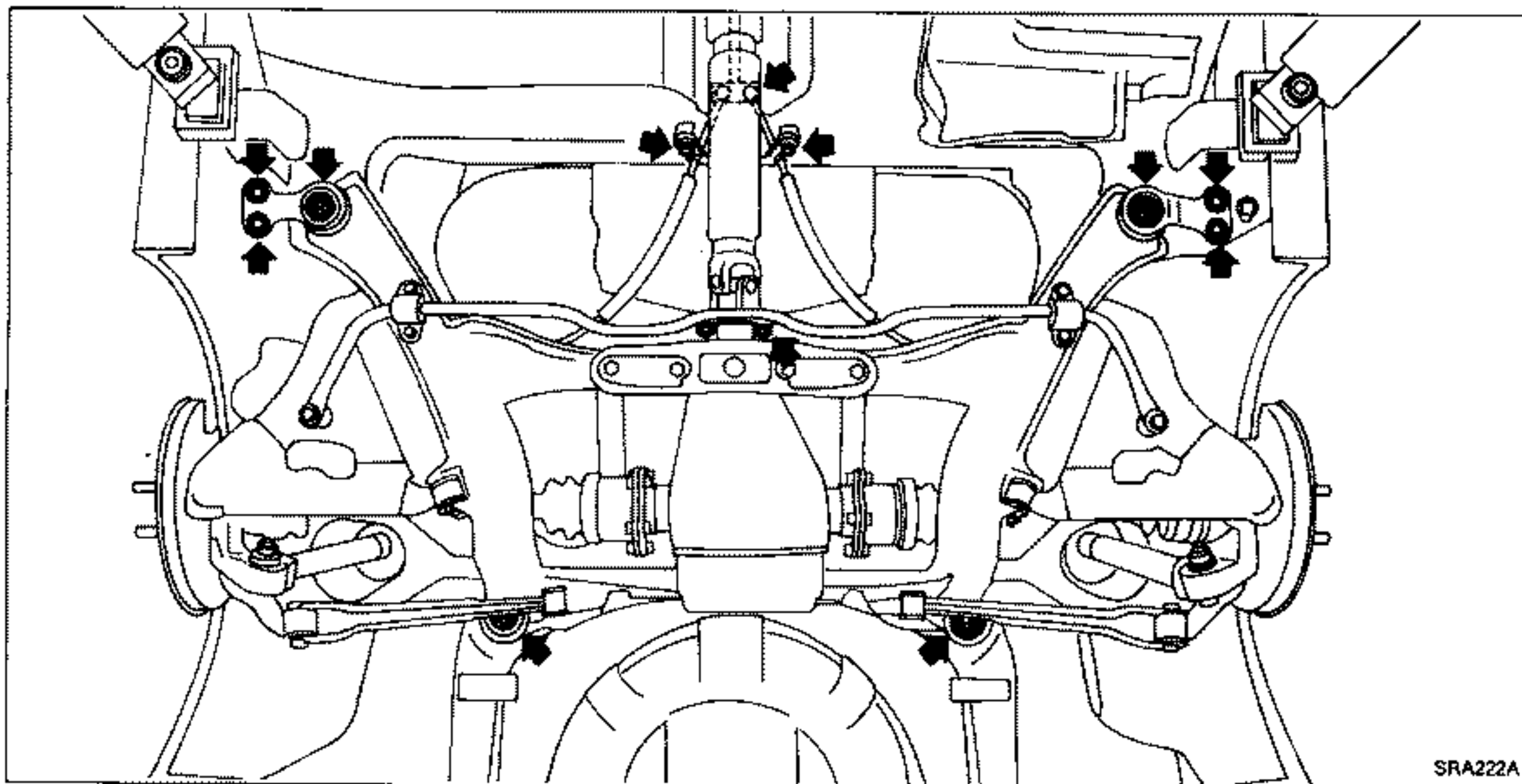

- Remove exhaust tube.
- Disconnect propeller shaft rear end.
- Disconnect hand brake wire front end.

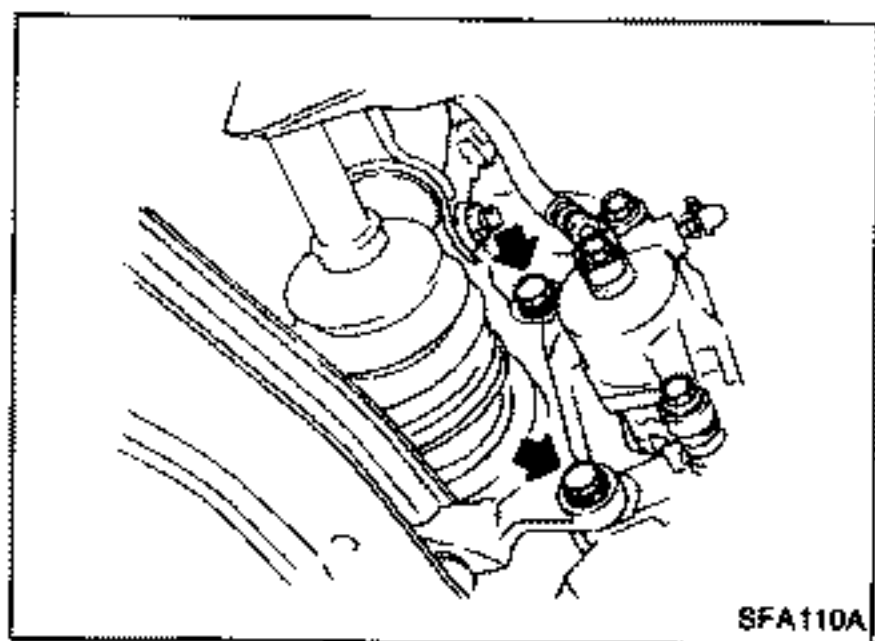

- Remove brake caliper assembly.  
**Brake line need not be disconnected from brake caliper.**  
**Be careful not to depress brake pedal, or piston will pop out.**  
**Do not pull or twist brake hose.**

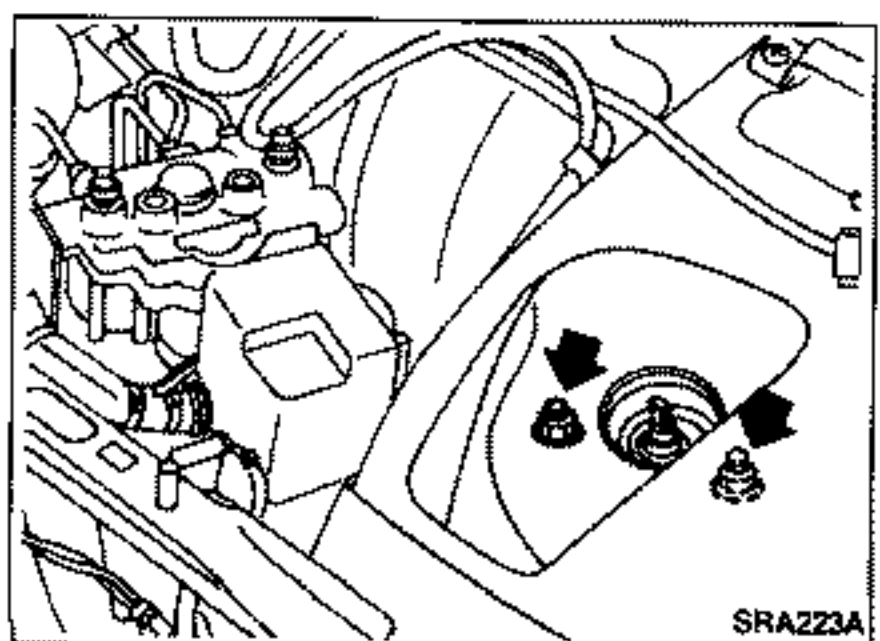

- Remove upper end nuts of shock absorber.  
**Do not remove piston rod lock nut.**
- Remove suspension member fixing nuts. Then draw out rear axle and rear suspension assembly.

## Removal

Remove shock absorber upper and lower fixing nuts.  
**Do not remove piston rod lock nut on vehicle.**

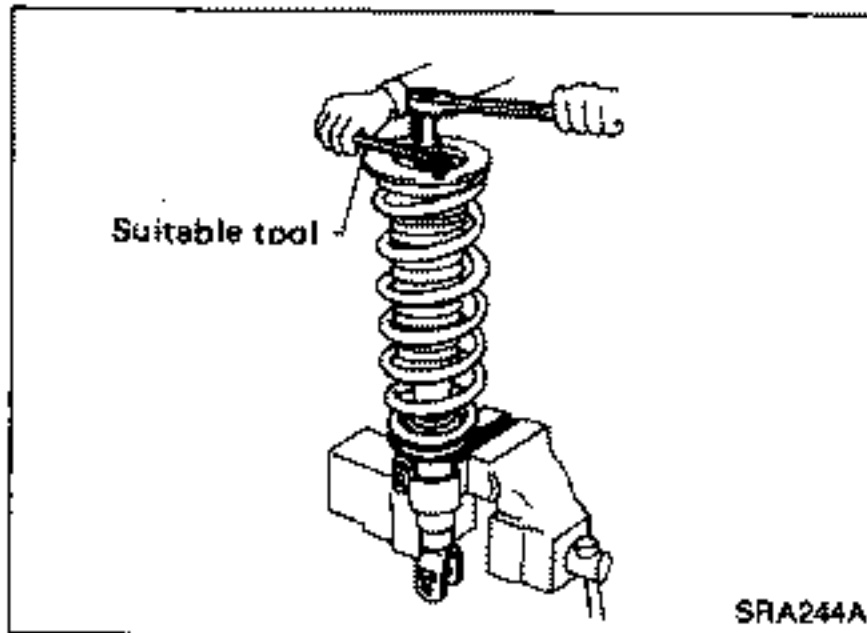

## Disassembly

1. Set shock absorber on vise with attachment, then loosen piston rod lock nut.

**Do not remove piston rod lock nut.**

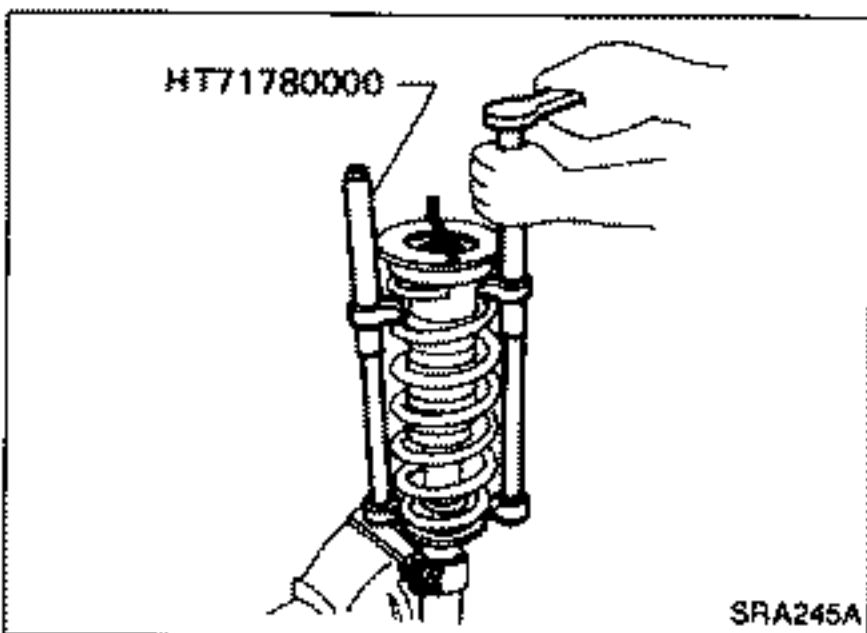

2. Compress spring with Tool so that the strut upper spring seat can be turned by hand.

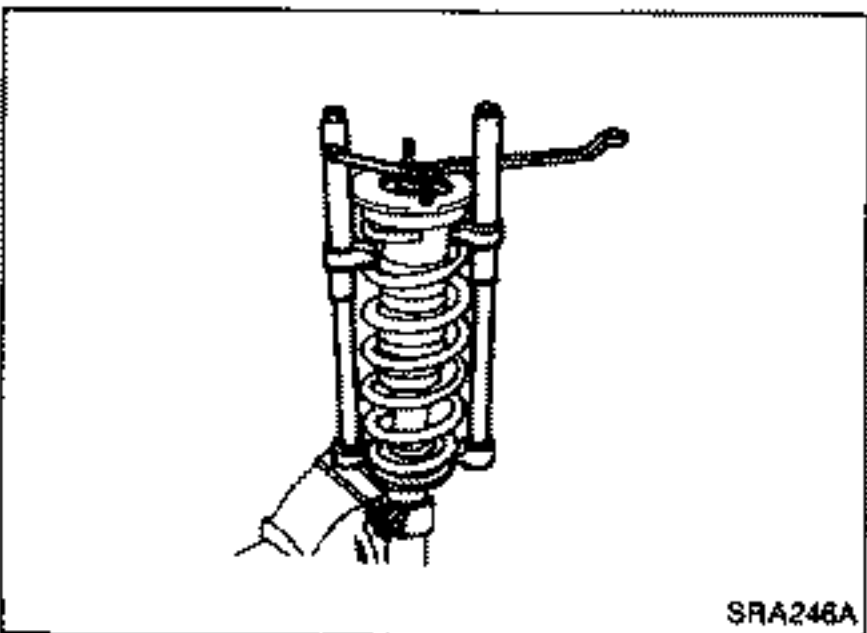

3. Remove piston rod lock nut.

## Inspection

### SHOCK ABSORBER ASSEMBLY

- Check for smooth operation through a full stroke, both compression and extension.
- Check for oil leakage occurring on welded or gland packing portions.
- Check piston rod for cracks, deformation or other damage. Replace if necessary.

## REAR SUSPENSION — Coil Spring and Shock Absorber

### Inspection (Cont'd)

#### UPPER RUBBER SEAT AND BUSHING

Check rubber parts for deterioration or cracks.  
Replace if necessary.

#### COIL SPRING

Check for cracks, deformation or other damage.  
Replace if necessary.

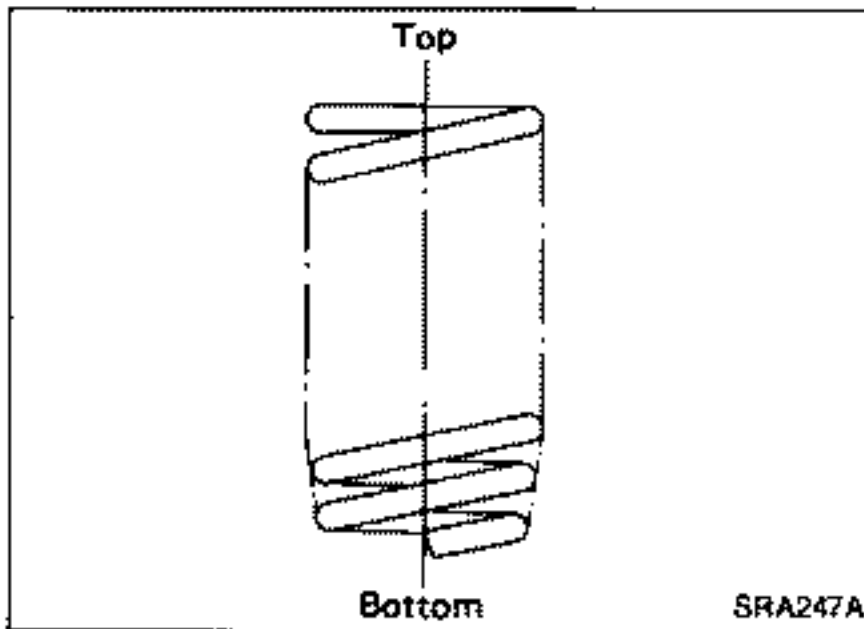

### Assembly

- When installing coil spring, be careful not to reverse top and bottom direction. (Top end is flat.)

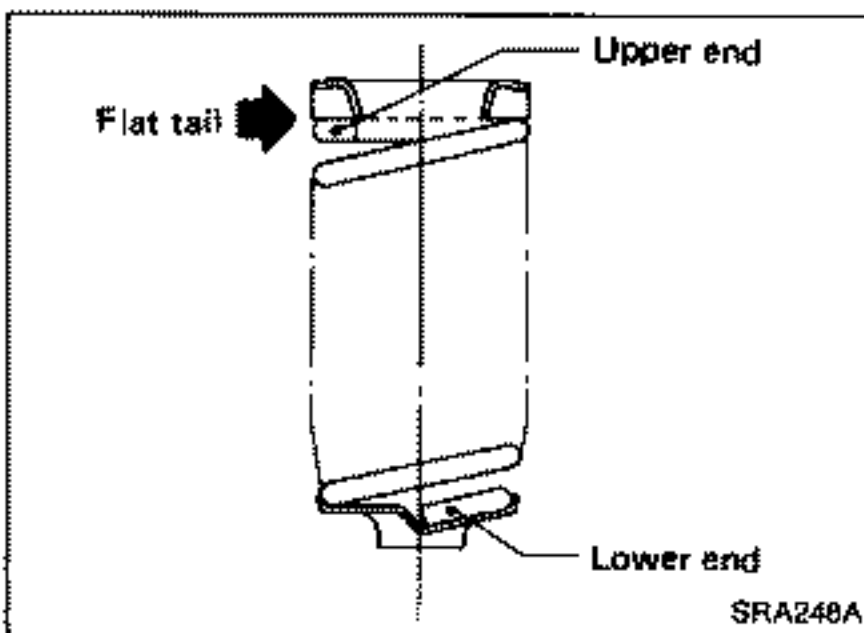

- When installing coil spring on strut, it must be positioned as shown in figure at left.

## Removal and Installation

- Refer to "Removal and Installation" in REAR SUSPENSION.

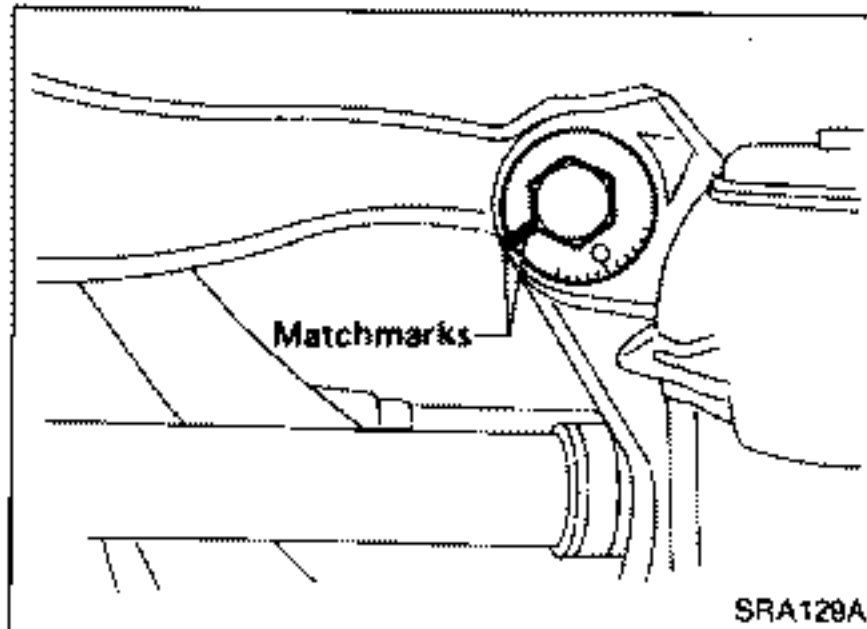

**Before removing, put matchmarks on adjusting pin.**

- When installing, final tightening must be done at curb weight with tires on ground.
- After installation, check wheel alignment. Refer to "Rear Wheel Alignment" in CHECK AND ADJUSTMENT — On vehicle.

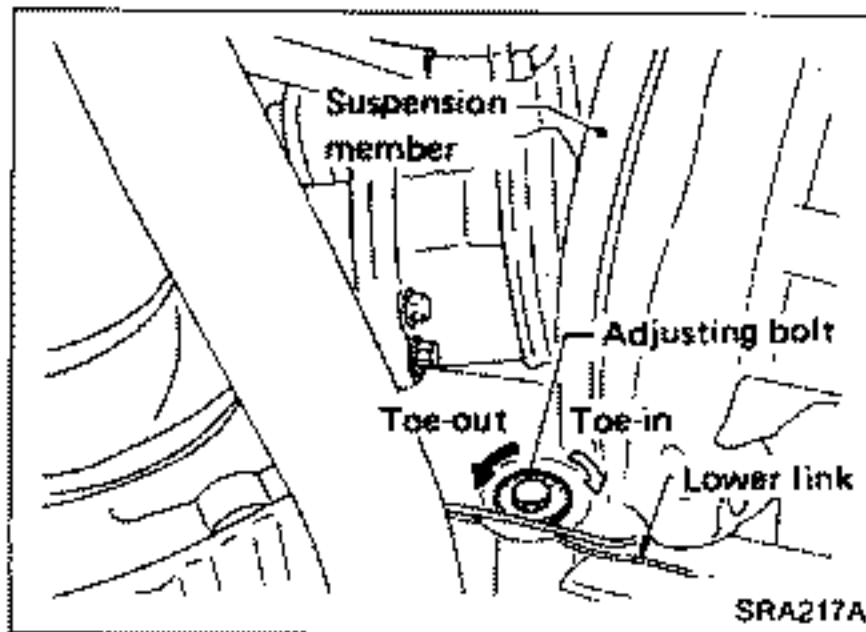

## Inspection

### REAR SUSPENSION MEMBER

Replace suspension member assembly if cracked or deformed or if any part (insulator, for example) is damaged.

### UPPER AND LOWER LINKS

Replace upper or lower link as required if cracked or deformed or if bushing is damaged.

## Inspection (Cont'd)

### SUSPENSION LOWER BALL JOINT

- Measure swing force, turning torque and vertical end play in axial direction. (Use same measurement procedures as that of section FA.)
- If ball stud is worn, play in axial direction is excessive, or joint is hard to swing, replace lower arm.

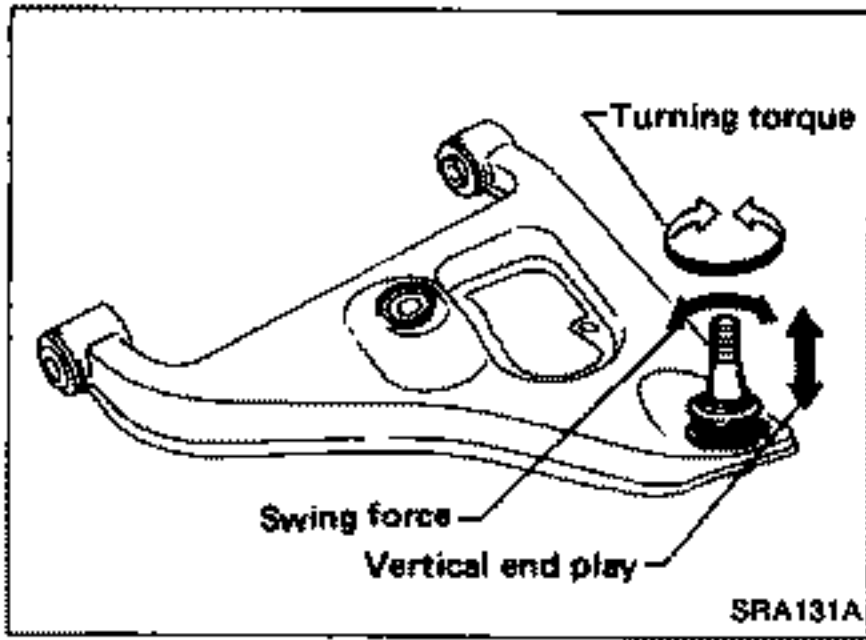

Ball joint specifications	Swing force	7.8 - 54.9 N (0.8 - 5.6 kg, 1.8 - 12.3 lb)
	Turning torque	0.5 - 3.4 N·m (5 - 35 kg-cm, 4.3 - 30.4 in-lb)
	Vertical end play	0 mm (0 in)

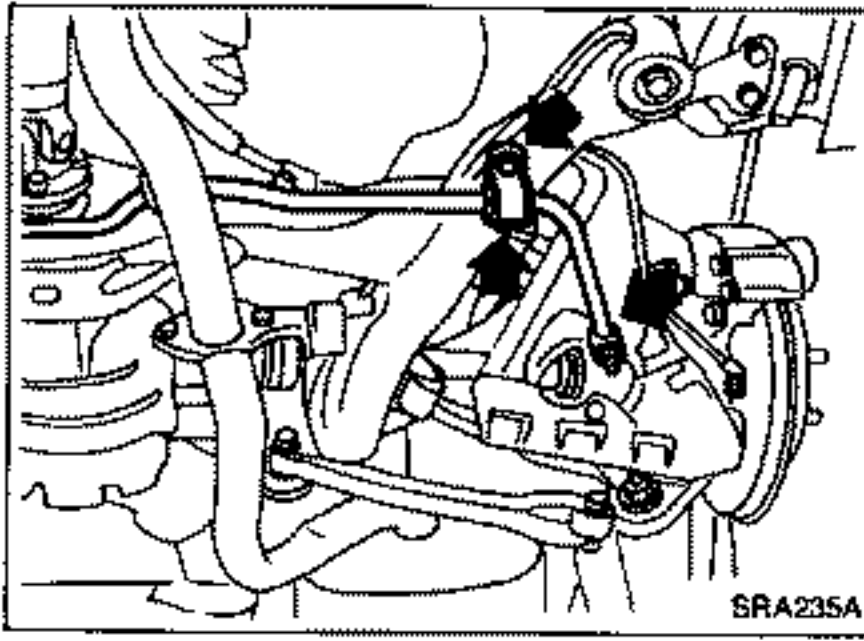

## Removal

Remove connecting rod and clamp.

## Inspection

- Check stabilizer bar for deformation or cracks. Replace if necessary.
- Check rubber bushings for deterioration or cracks. Replace if necessary.

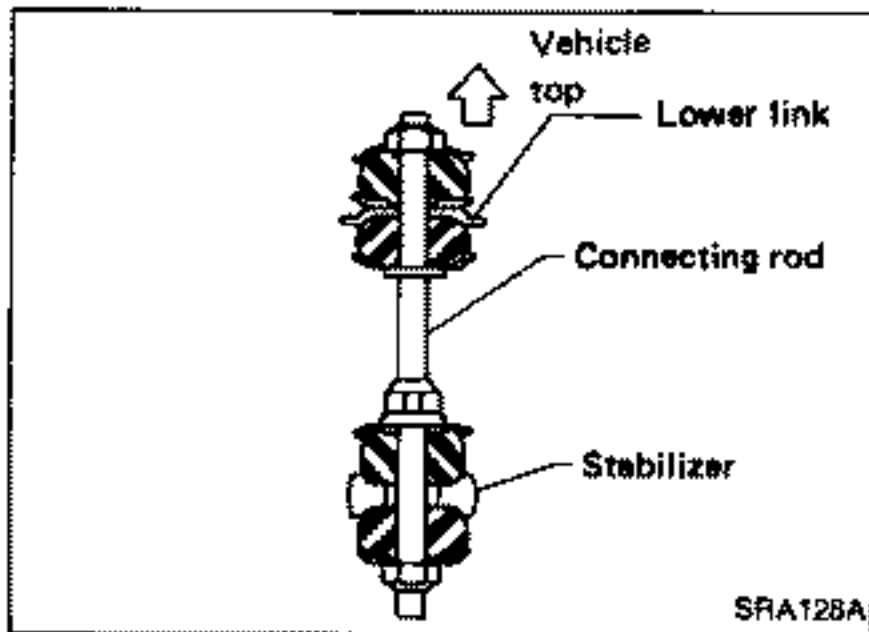

## Installation

When installing connecting rod, make sure direction is correct (as shown at left).

# ADJUSTABLE SHOCK ABSORBER

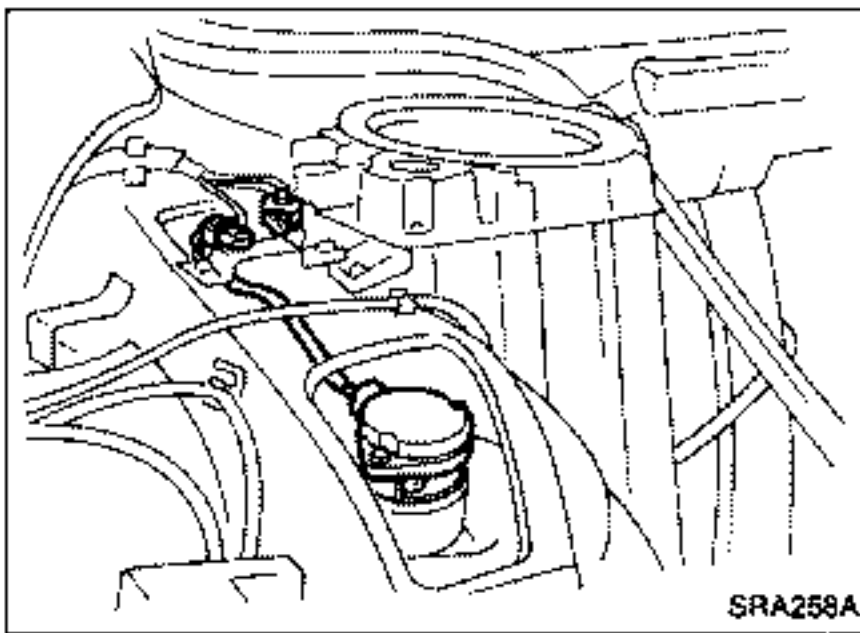
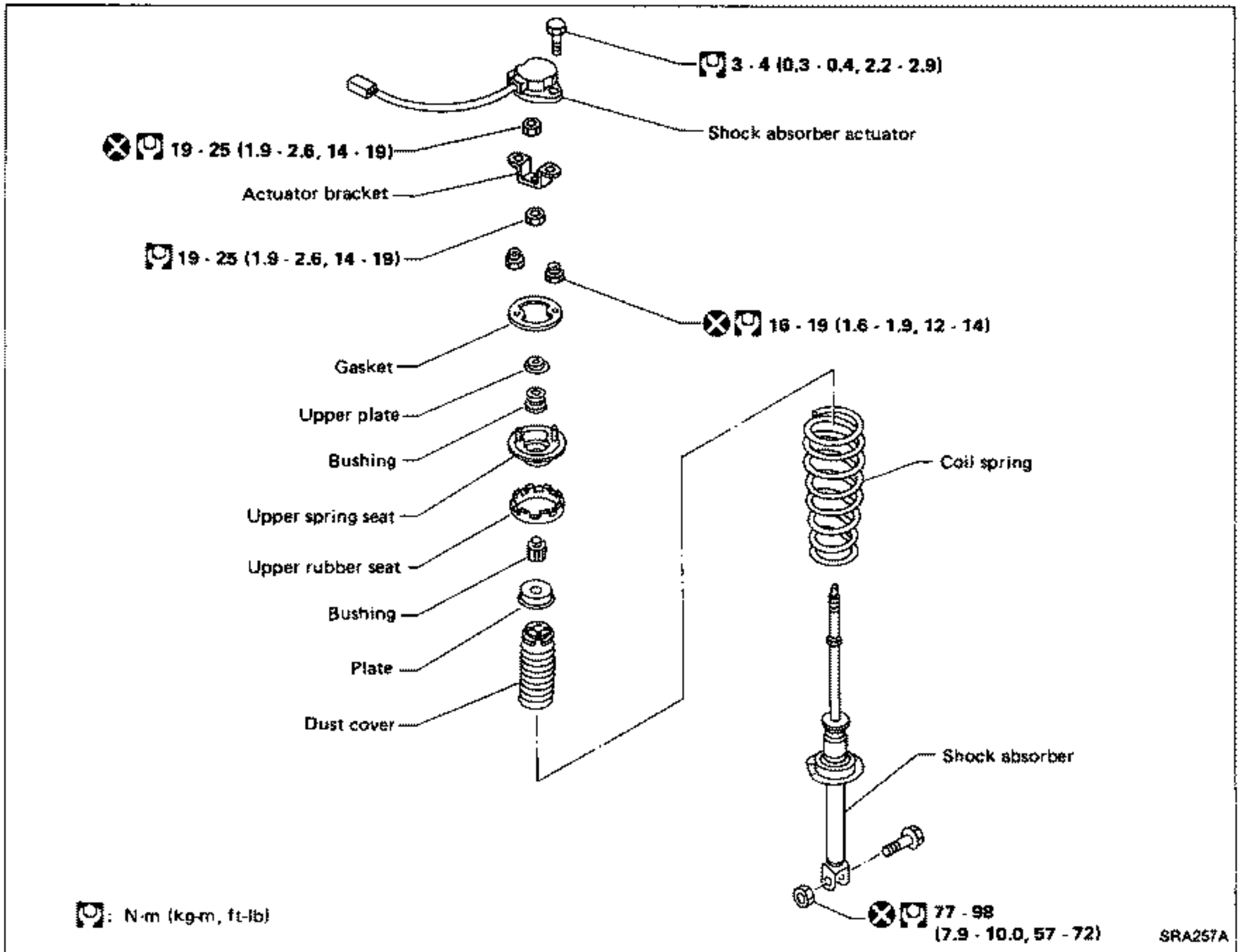

## Removal and Installation

- Remove room trim. Refer to section BF.
- Disconnect sub-harness connector.
- Remove shock absorber actuator fixing bolts.

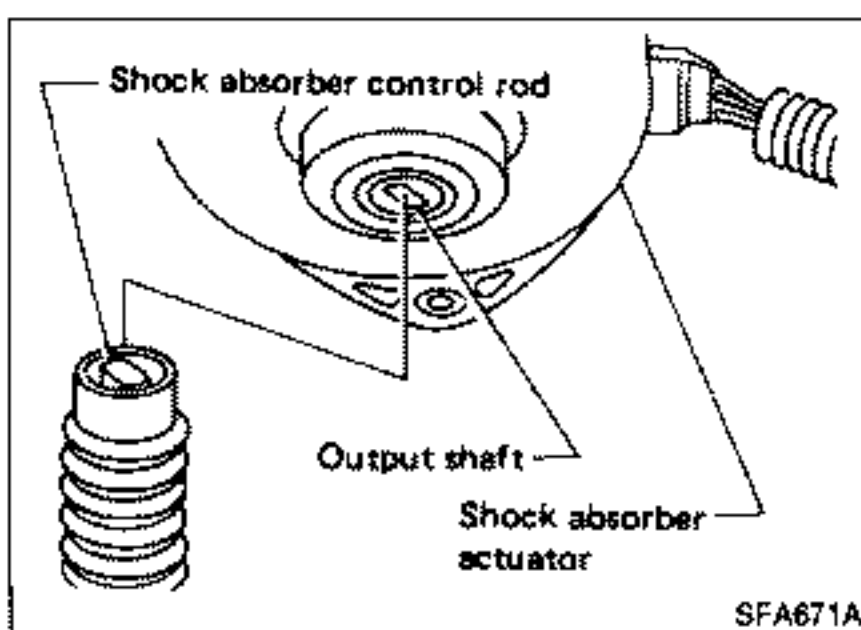

- Before installing actuator, ensure angle of shock absorber control rod is aligned with that of actuator output shaft. Otherwise, actuator may be damaged.
- Refer to REAR SUSPENSION for other procedures.



## Inspection

- Replace shock absorber assembly if it is damaged.  
Refer to REAR SUSPENSION — Coil Spring and Shock Absorber.

## Component Parts and Harness Connector Location

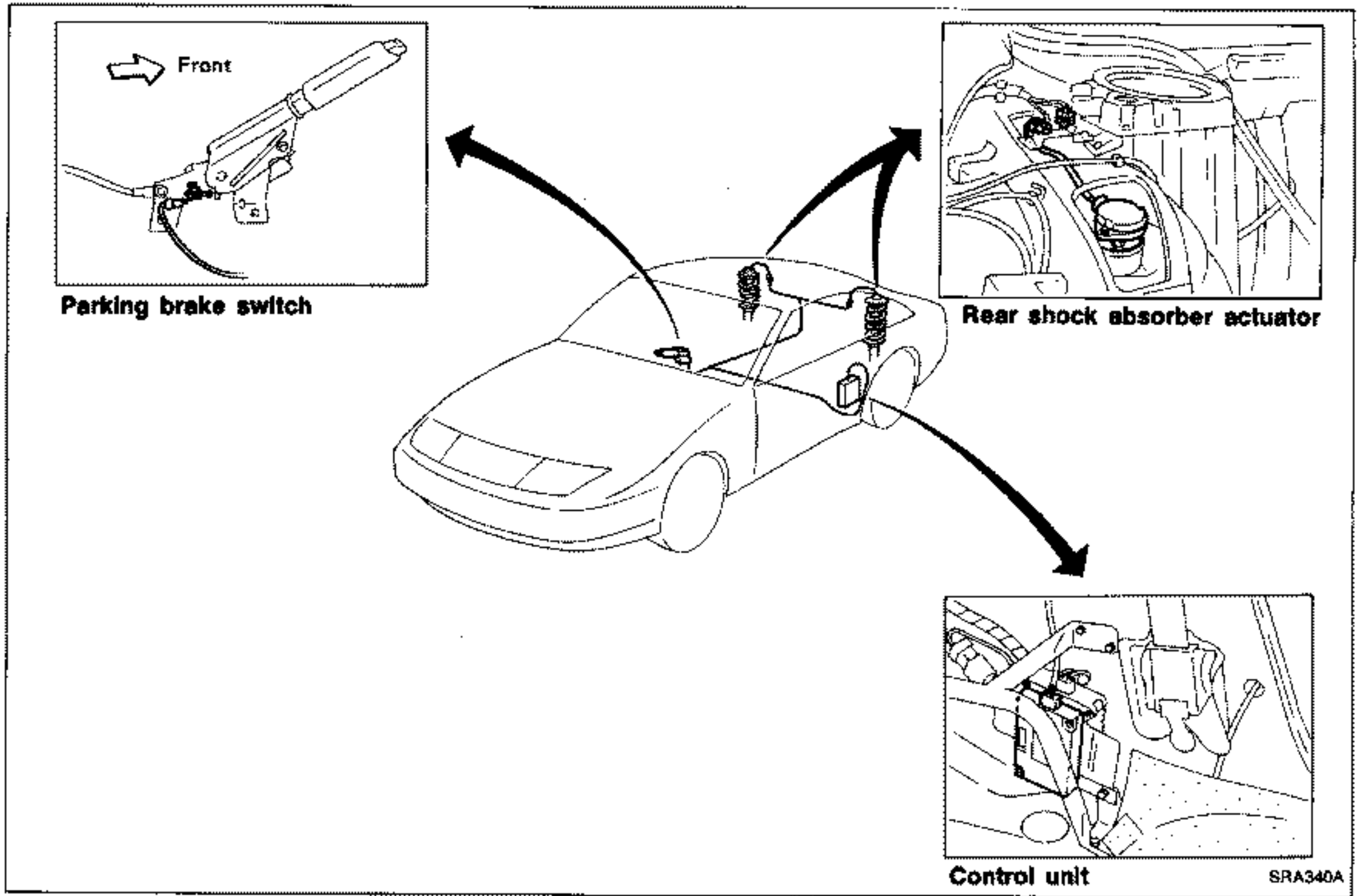

## Circuit Diagram for Quick Pinpoint Check

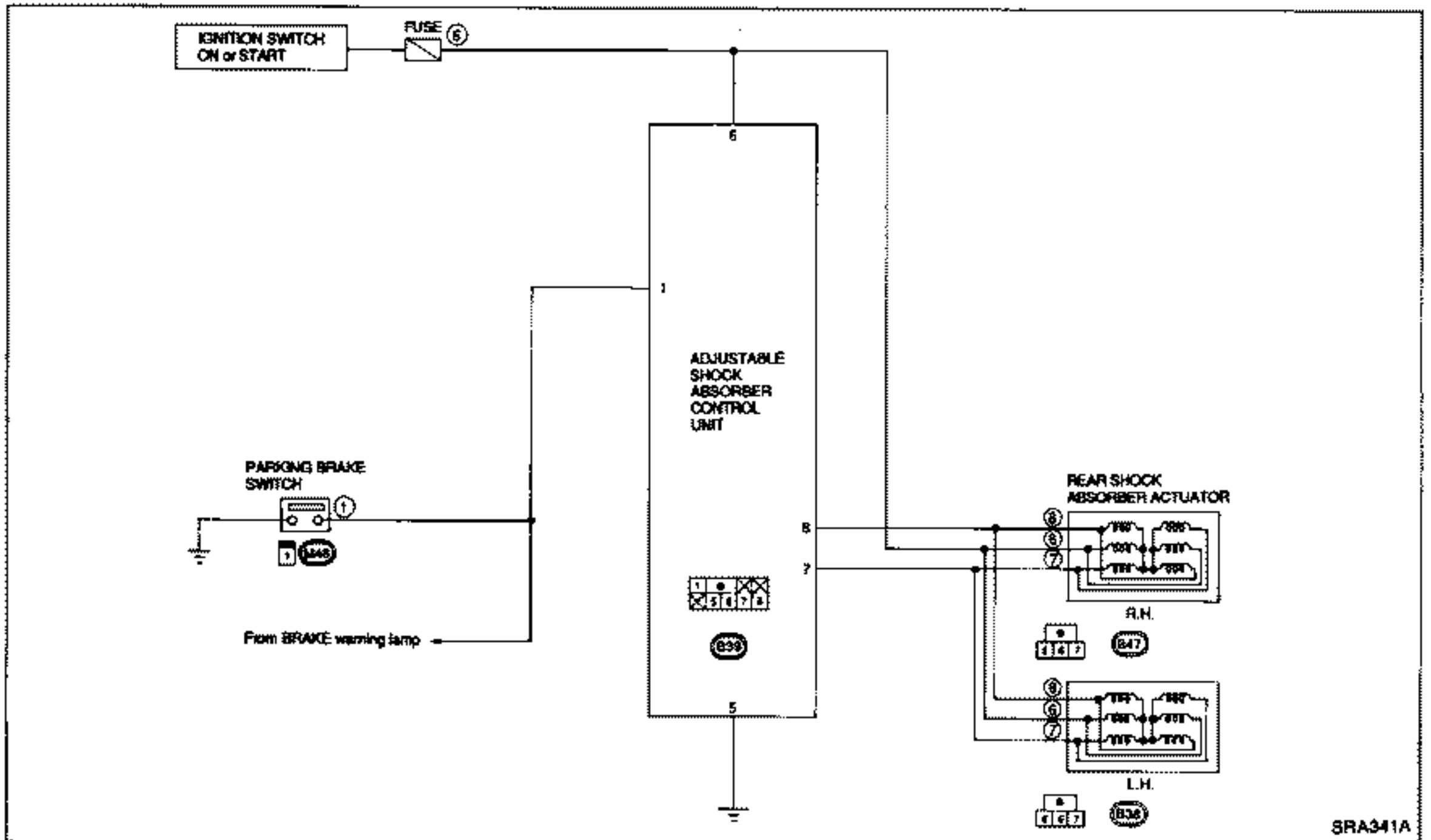

Wiring Diagram

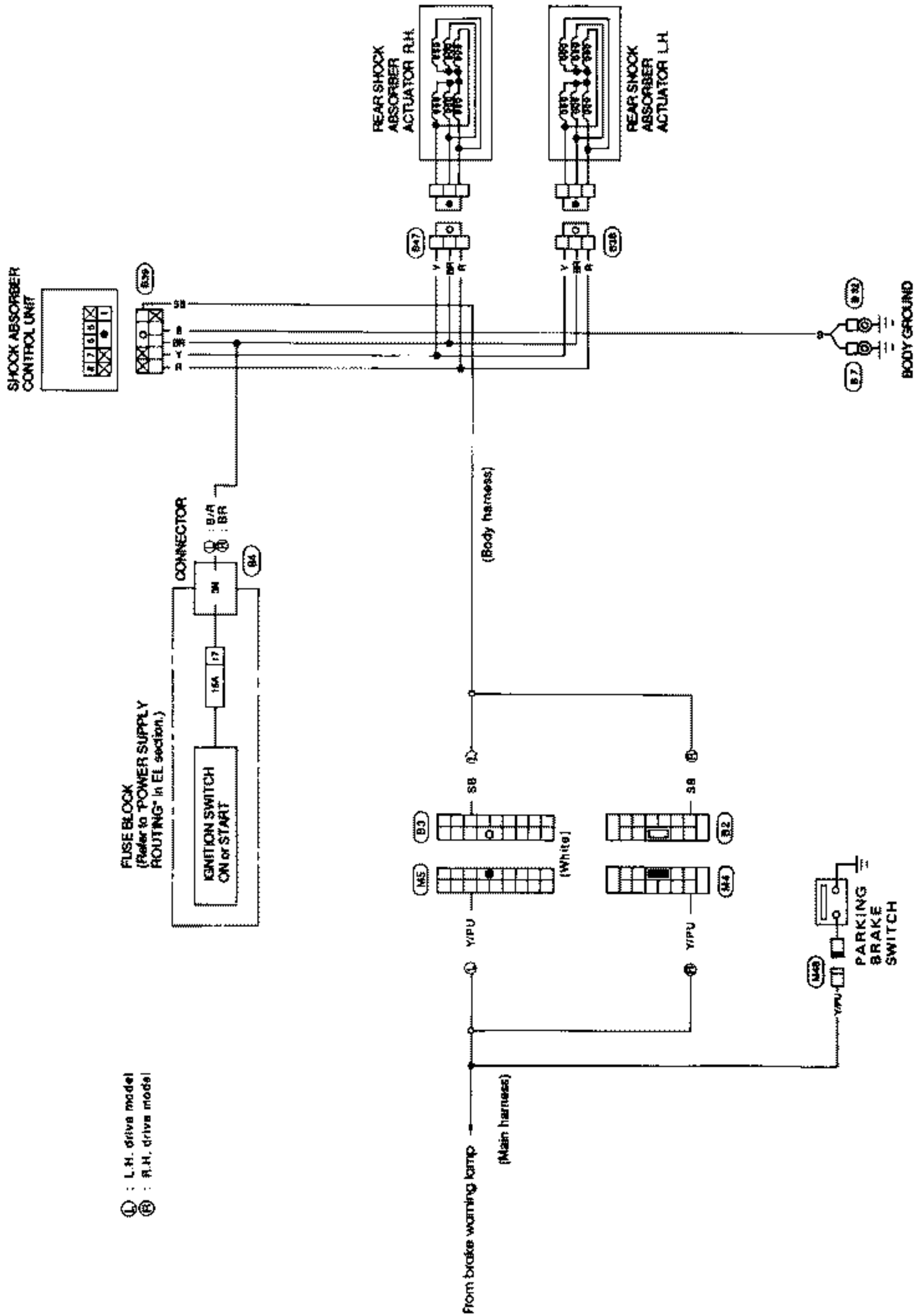

Ⓛ : L.H. drive model  
 Ⓡ : R.H. drive model

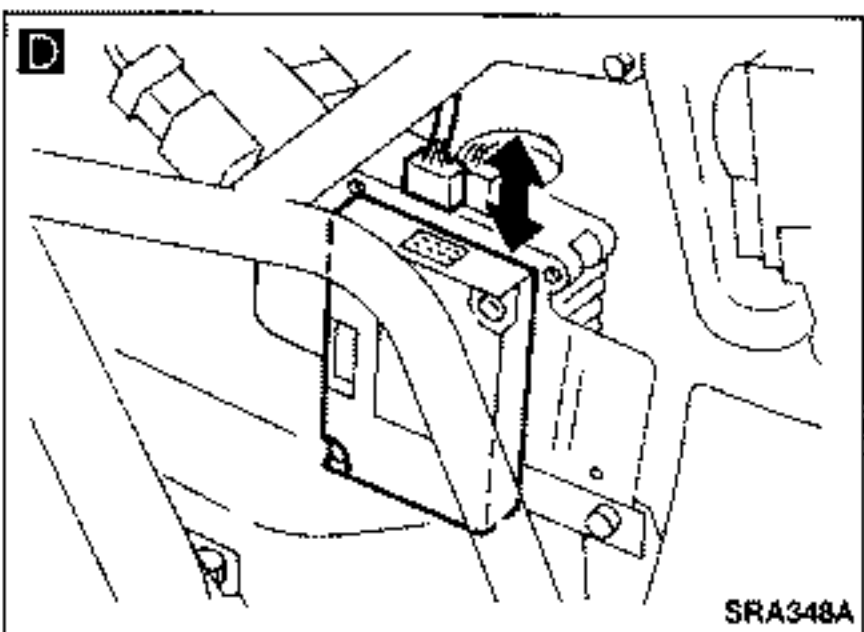
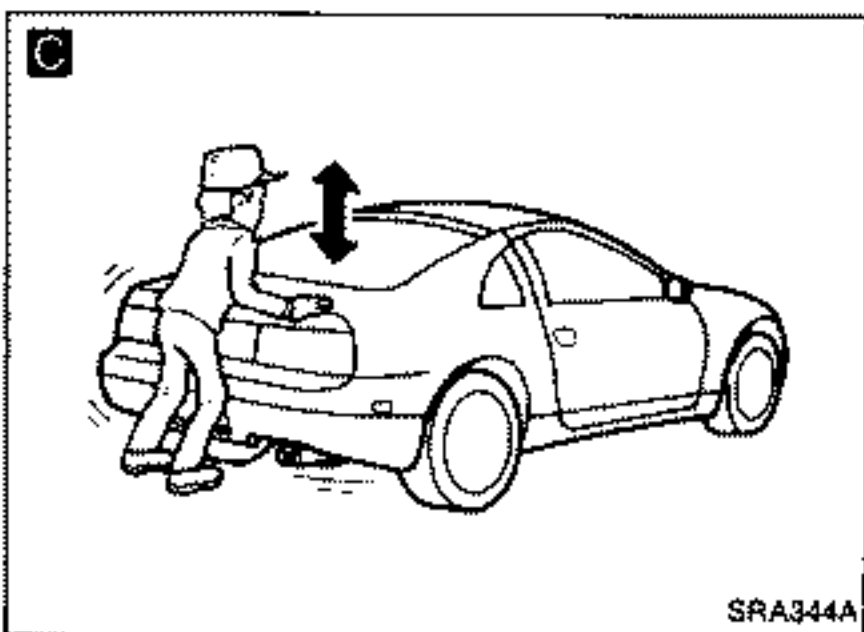
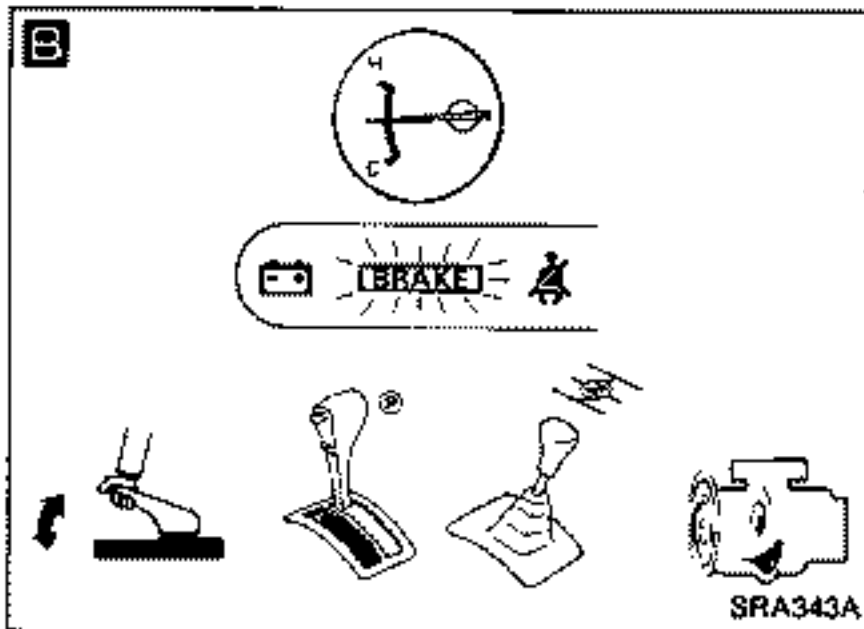
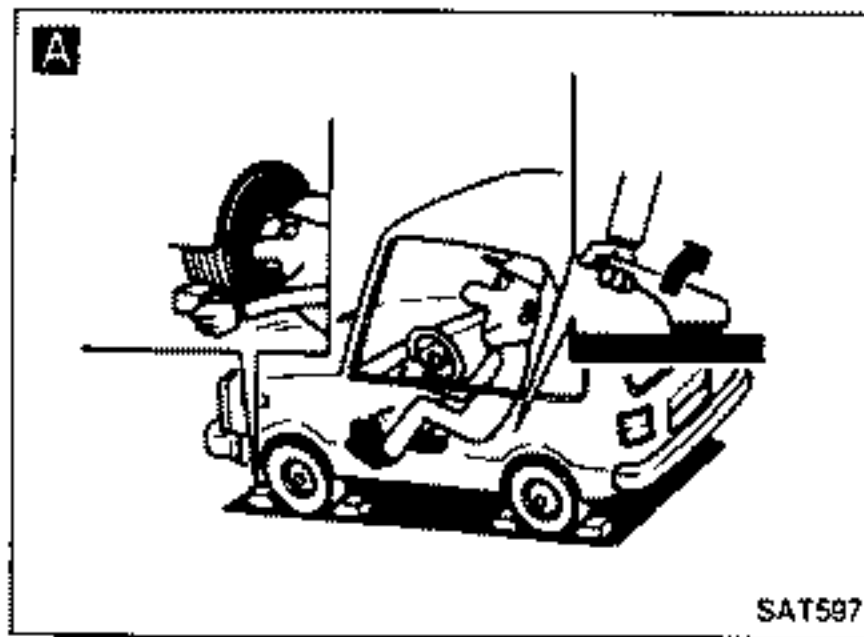

## Diagnostic Procedure

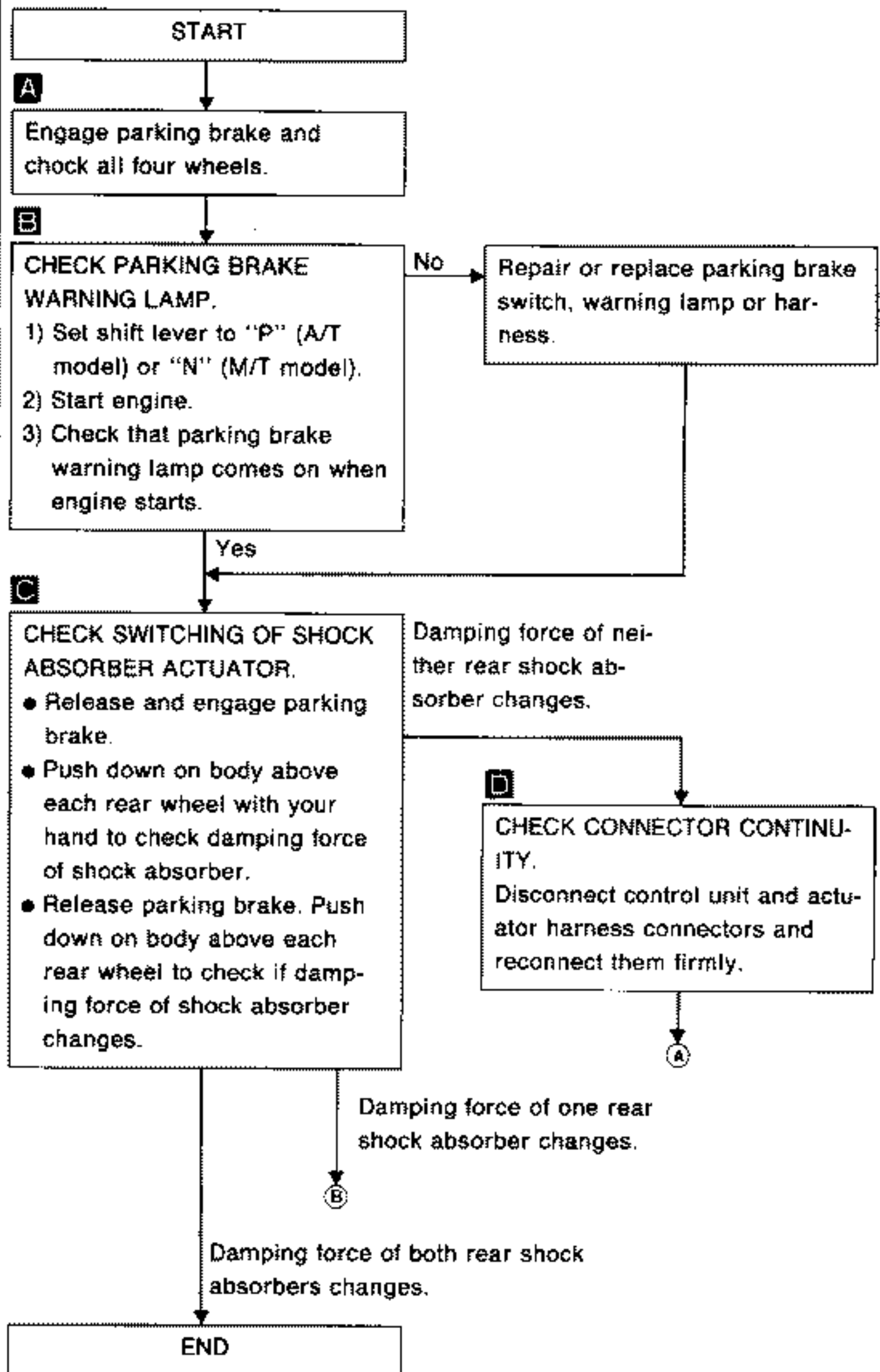

# ADJUSTABLE SHOCK ABSORBER — Trouble Diagnoses

## Diagnostic Procedure (Cont'd)

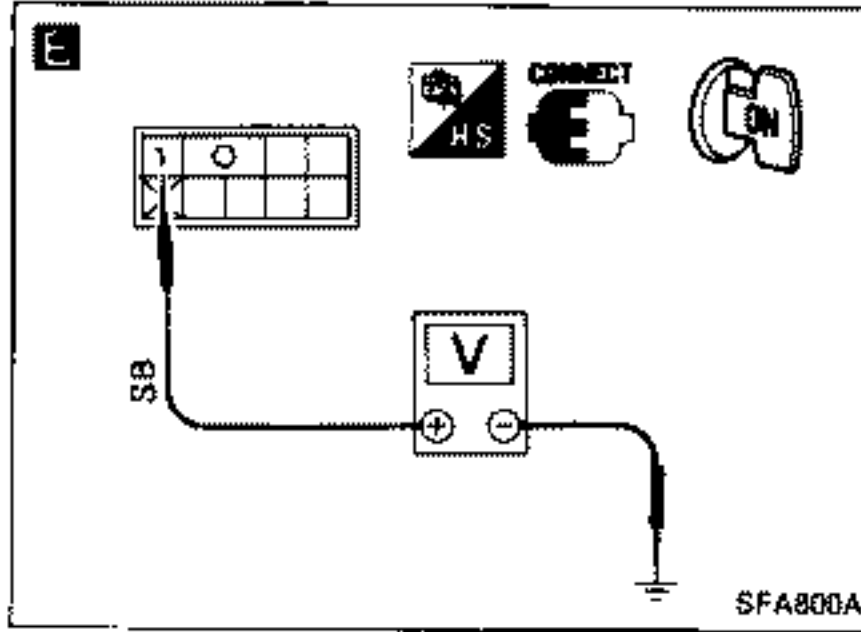

**E**

**CHECK CONTROL UNIT INPUT SIGNAL.**  
 Check control unit input signal at terminal ①.

- Turn ignition switch "ON".
- Parking brake lever:
 

Released ...	} O.K.
Approx. 12V	
Engaged ... 0V	

12V are indicated regardless of parking brake lever position.

Repair or replace harness between control unit and parking brake switch.

0V are indicated regardless of parking lever position.

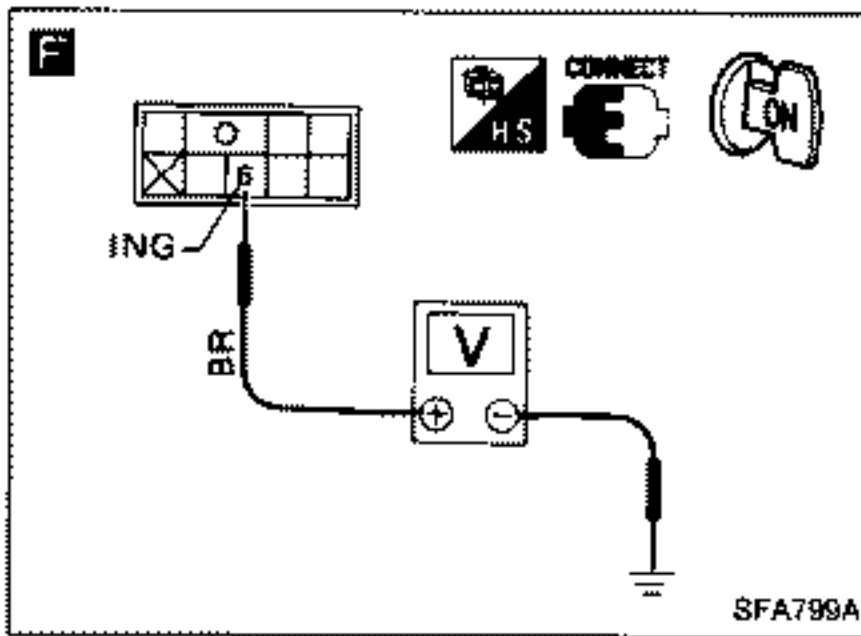

**F**

**CHECK CONTROL UNIT POWER SUPPLY.**

- 1) Turn ignition switch "ON".
- 2) Measure voltage across control unit terminal ⑥ and ground.

**Voltage:**  
**Approximately 12V ... O.K.**

Repair or replace harness between control unit and parking brake switch.

O.K.  
 Replace control unit.

N.G.  
 Check and repair fuse and power supply harness.

# ADJUSTABLE SHOCK ABSORBER — Trouble Diagnoses

## Diagnostic Procedure (Cont'd)

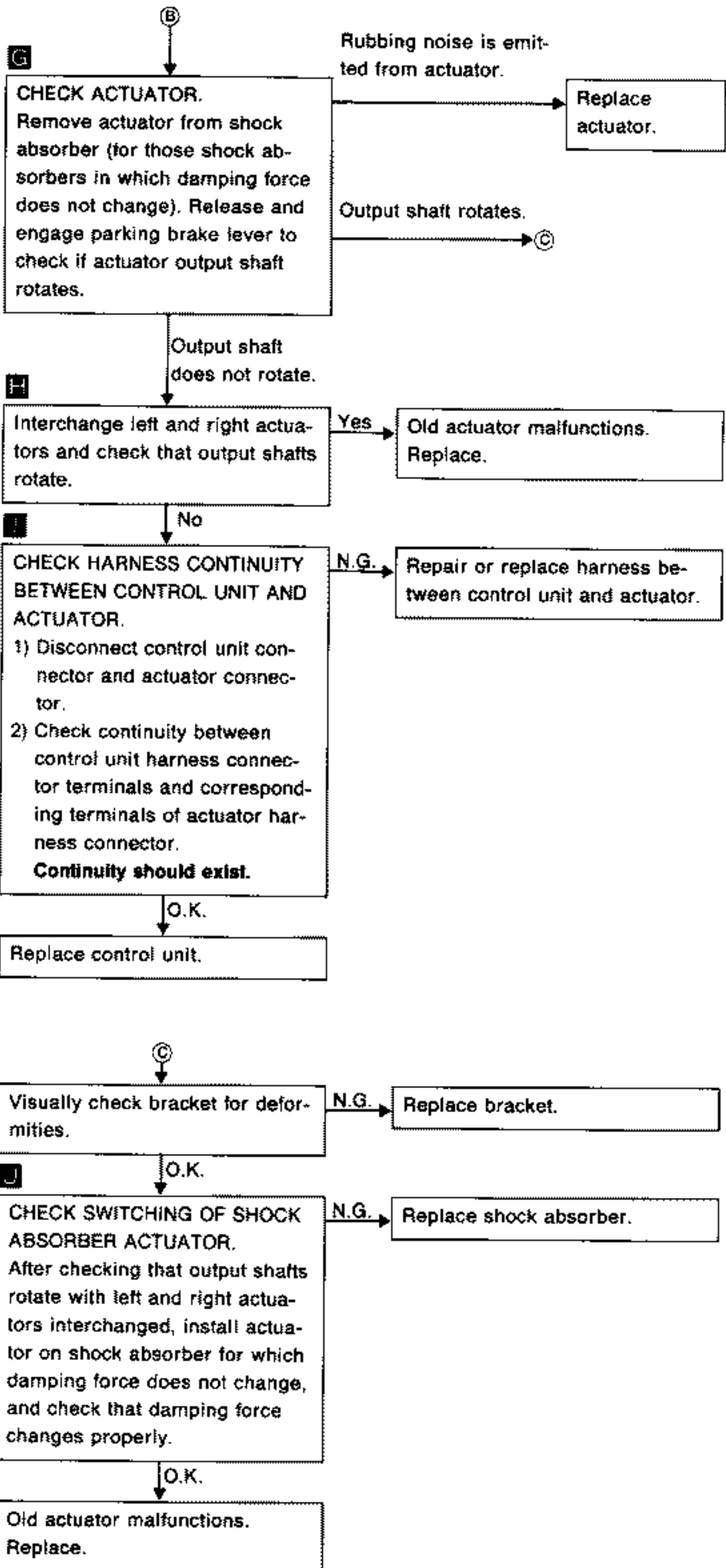
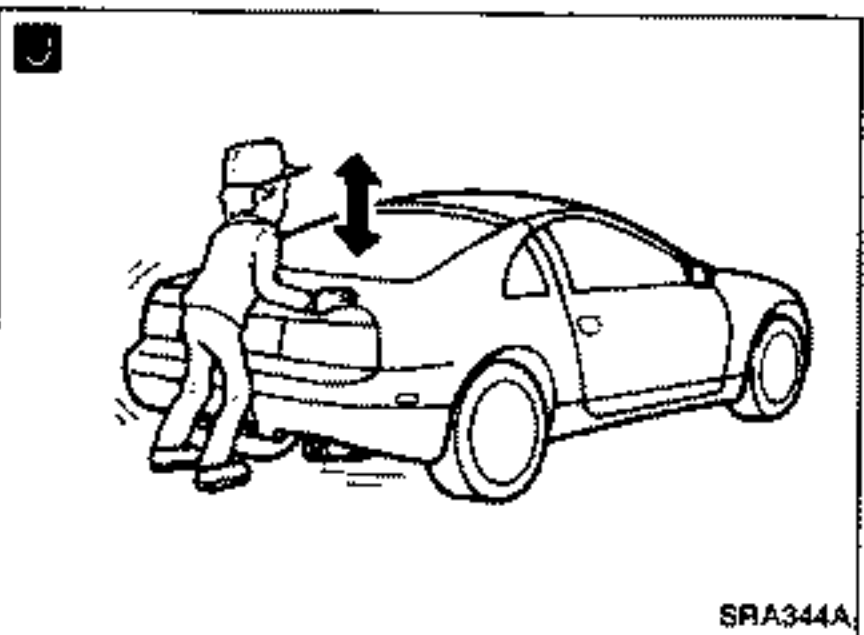
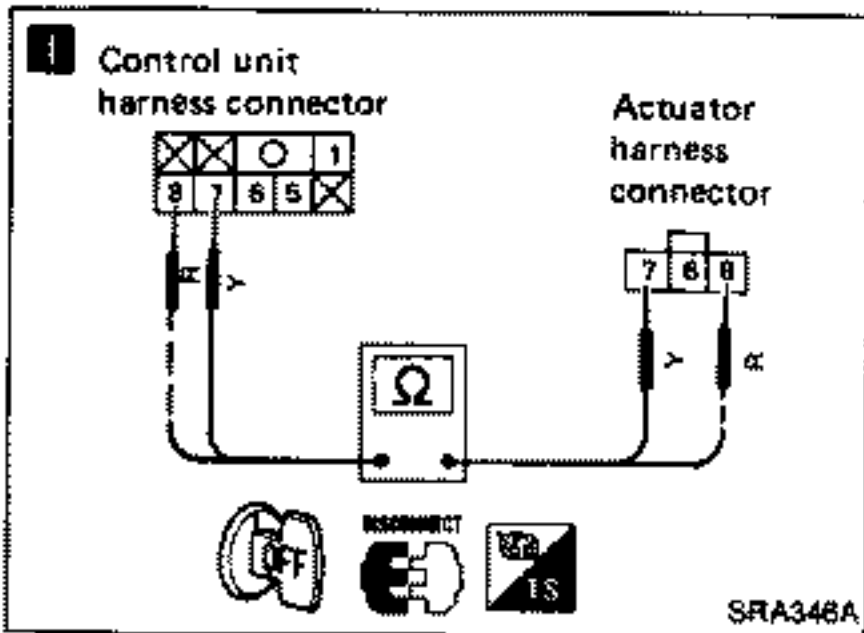
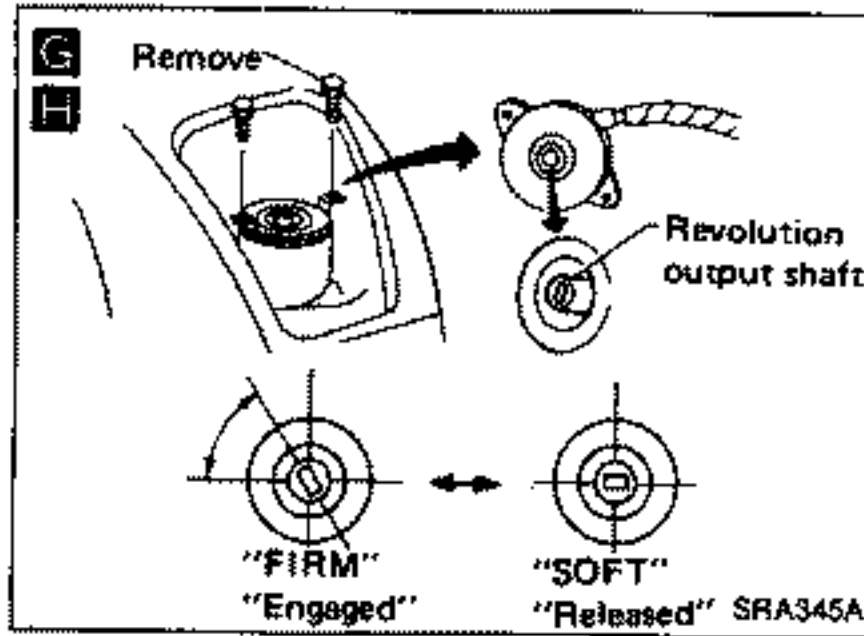

# ADJUSTABLE SHOCK ABSORBER — Trouble Diagnoses

## Diagnostic Procedure (Cont'd)

### CONTROL AND OPERATION OF SHOCK ABSORBER DAMPING FORCE

Parking brake lever	Damping force
Released	Soft
Engaged	Firm

### CONTROL UNIT INSPECTION TABLE

Terminal No.	Connected to	Standard value
①	Parking brake switch	Approx. 12V (parking brake lever released); 0V (parking brake lever engaged)
⑤	GND	0V
⑥	IGN	Approx. 12V
⑦	Rear actuator "Firm"	When select signal is emitted, 12V (approx.) instantaneously drops to 2 - 3V.
⑧	Rear actuator "Soft"	When select signal is emitted, 12V (approx.) instantaneously drops to 2 - 3V.

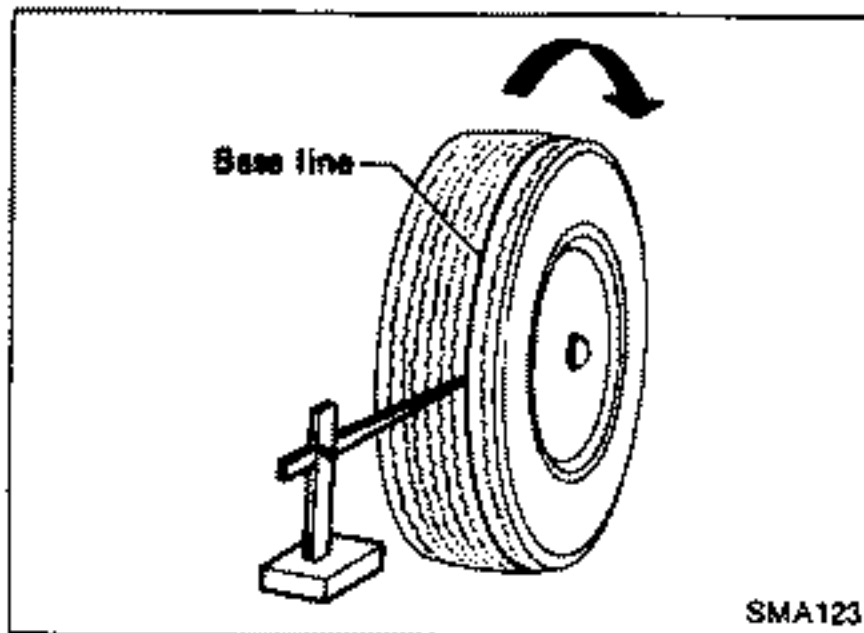

## Rear Wheel Alignment

### TOE-IN

1. Draw a base line across the tread.  
After lowering rear of vehicle, move it up and down to eliminate friction.

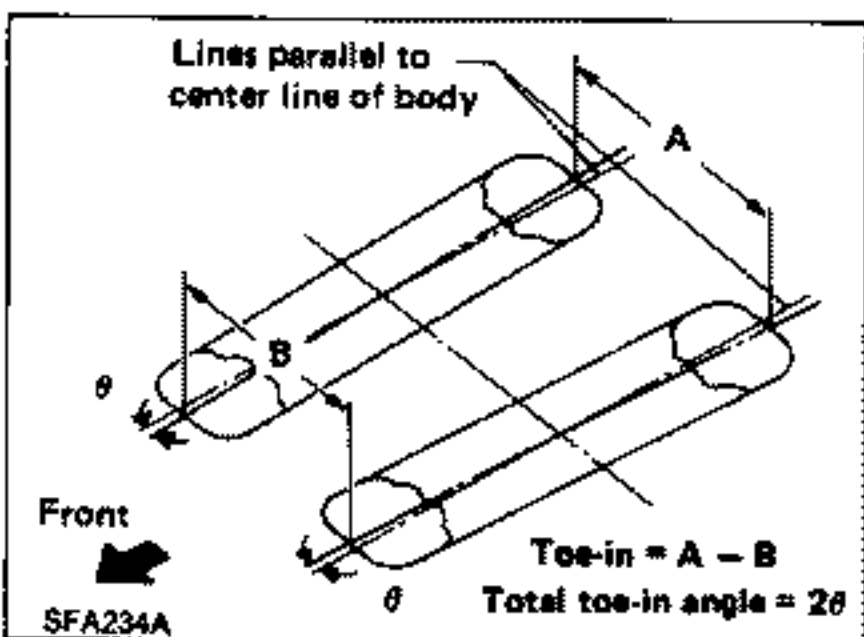

2. Measure toe-in.  
Measure distance "A" and "B" at the same height as hub center.

Toe-in:

$$A - B$$

$$0 - 4 \text{ mm (0 - 0.16 in)}$$

$$2\theta \text{ (Total toe-in angle)}$$

$$0' - 22'$$

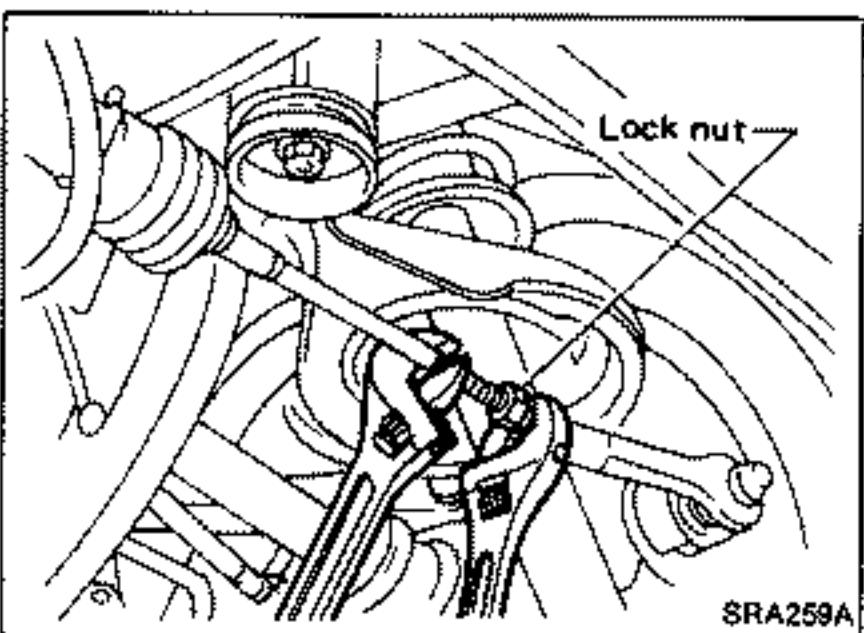

3. Adjust toe-in by varying length of power cylinder lower links.

- (1) Loosen lock nuts.
- (2) Adjust toe-in by turning lower links forward or backward.

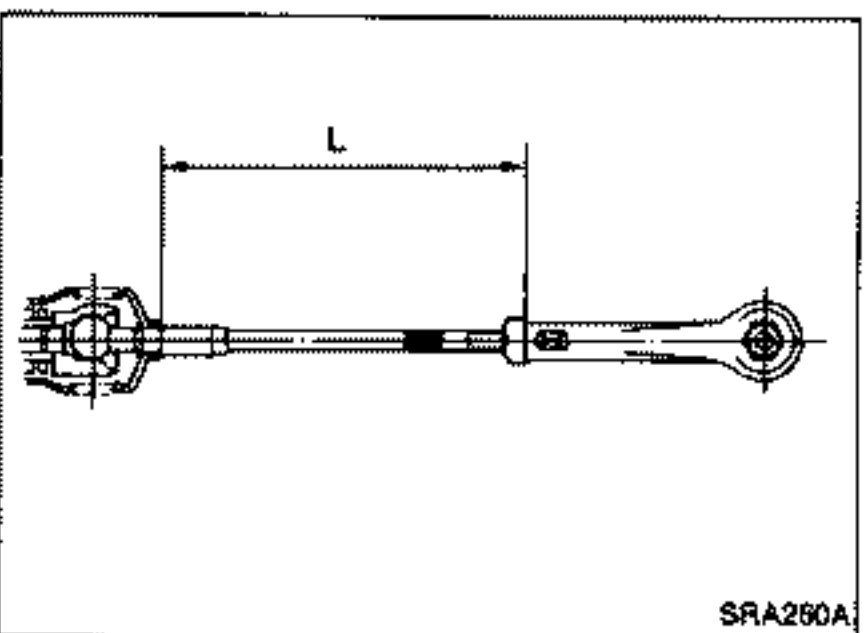

Make sure both lower links are the same length.

Standard length "L":

$$185.5 \text{ mm (7.30 in)}$$

- (3) Tighten lock nuts to the specified torque.

$$\left[ \text{Torque symbol} \right]: 37 - 46 \text{ N}\cdot\text{m}$$

$$(3.8 - 4.7 \text{ kg}\cdot\text{m, 27 - 34 ft}\cdot\text{lb})$$

- Refer to CHECK AND ADJUSTMENT — On-vehicle for other procedures.



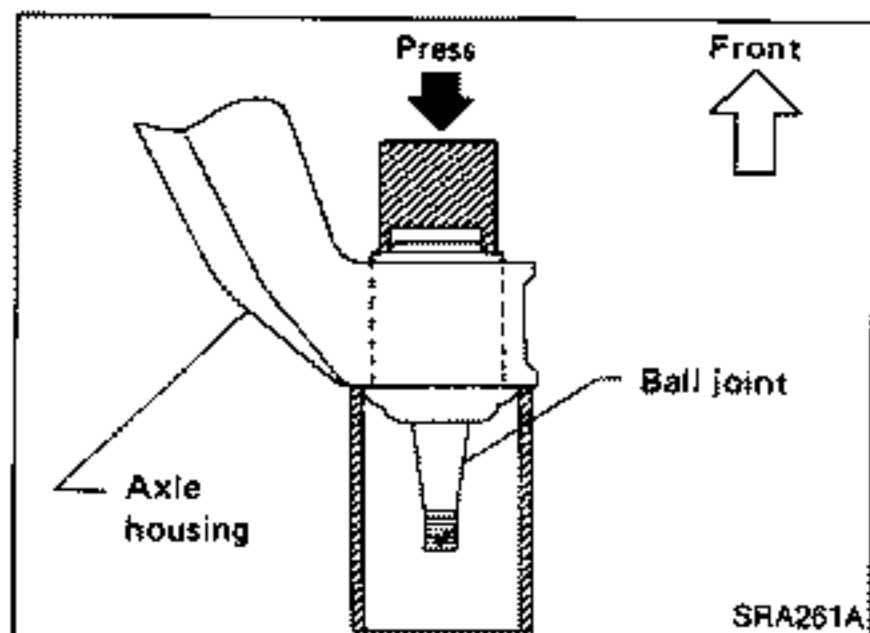

## Rear Axle Housing Ball Joint

### REMOVAL

- Remove ball joint snap ring.
- Press out ball joint from axle housing.

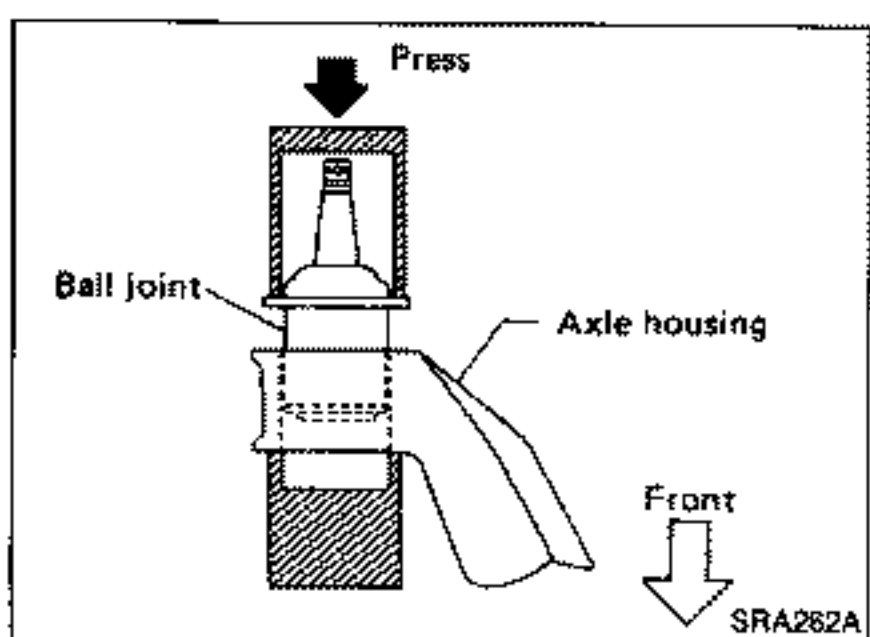

### ASSEMBLY

- Press new ball joint assembly into axle housing.
- Install snap ring into groove of ball joint.
- Refer to REAR AXLE — Wheel Hub and Axle Housing for other procedures.
- Refer to ST section for power cylinder and SUPER HICAS — Trouble Diagnoses.

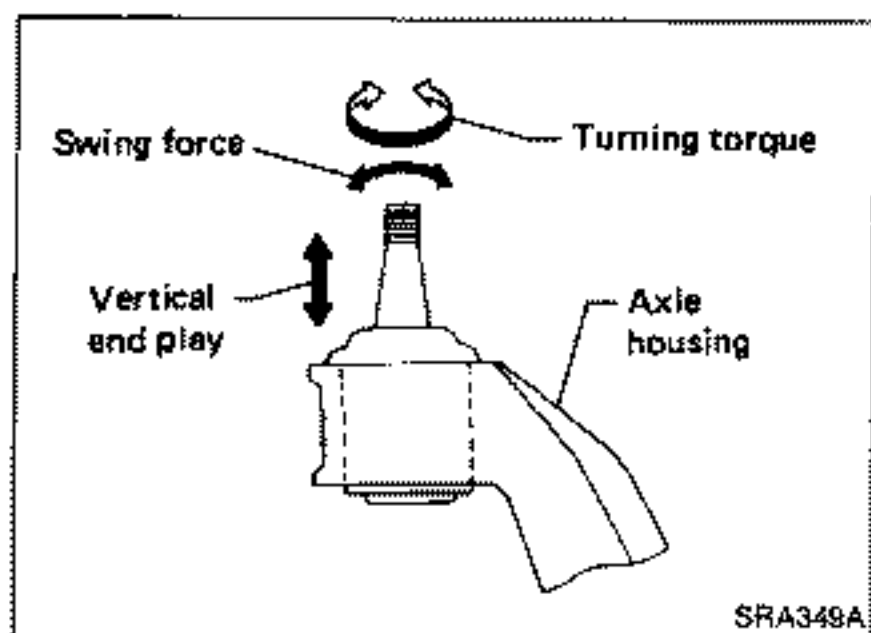

### INSPECTION

- Measure swing force, turning torque and vertical end play in axial direction.
- If ball joint is worn, play in axial direction is excessive, or joint is hard to swing, replace ball joint.

Ball joint specifications	Swing force	6.9 - 68.6 N (0.7 - 7.0 kg, 1.5 - 15.4 lb)
	Turning torque	0.3 - 2.9 N·m (3 - 30 kg-cm, 2.6 - 26.0 in-lb)
	Vertical end play	0 mm (0 in)

# SERVICE DATA AND SPECIFICATIONS (S.D.S.)

## General Specifications

### COIL SPRING

Applied model	Australia		Europe	
	VG30DE		VG30DETT	
Wire diameter	mm (in)	11.5 (0.453)		
Coil diameter	mm (in)	100 (3.94)		
Free length	mm (in)	380 (14.96)	370 (14.57)	
Spring constant	N/mm (kg/mm, lb/in)	21.6 (2.2, 123)	25.5 (2.6, 146)	
Identification color		Purple x 1, Pink x 1	Yellow x 2, Pink x 1	

### SHOCK ABSORBER

Applied model	Australia		Europe	
	VG30DE		VG30DETT	
Damping force [at 0.3 m (1.0 ft)/sec.]	N (kg, lb)		Firm	Soft
Expansion		873 - 1,187 (89 - 121, 196 - 267)	1,451 - 1,883 (148 - 192, 326 - 423)	991 - 1,226 (101 - 125, 223 - 276)
Compression		520 - 755 (53 - 77, 117 - 170)	745 - 1,020 (76 - 104, 168 - 229)	481 - 657 (49 - 67, 108 - 148)
Piston rod diameter	mm (in)	12.5 (0.492)	14.0 (0.551)	

### DRIVE SHAFT

Applied model	Australia		Europe	
	VG30DE		VG30DETT	
Joint type				
Final drive side	DS90		DS100	
Wheel side	ZF100		BF100	
Diameter	mm (in)			
Wheel side D <sub>1</sub>		30 (1.18)	33 (1.30)	
Grease	Nissan genuine grease or equivalent			
Specified amount of grease	g (oz)			
Final drive side		165 - 175 (5.82 - 6.17)	180 - 200 (6.35 - 7.05)	
Wheel side		165 - 175 (5.82 - 6.17)	170 - 190 (6.00 - 6.70)	
Boot length	mm (in)			
Final drive side (L <sub>1</sub> )		93 - 95 (3.66 - 3.74)	102.5 - 104.5 (4.04 - 4.11)	
Wheel side (L <sub>2</sub> )		96 - 98 (3.78 - 3.86)	101 - 103 (3.98 - 4.06)	

Final drive side

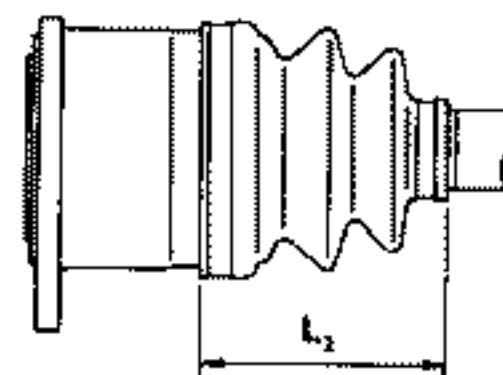

Wheel drive side

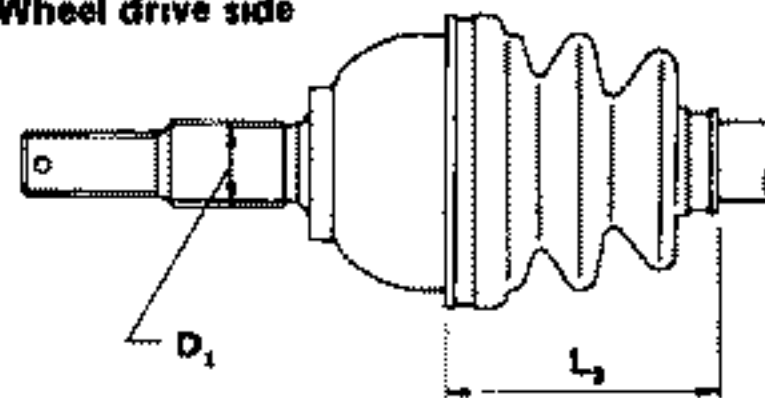

SRA322A

# SERVICE DATA AND SPECIFICATIONS (S.D.S.)

## General Specifications (Cont'd)

### REAR STABILIZER BAR

Applied model	Australia	Europe
	VG30DE	VG30DETT
Stabilizer diameter mm (in)		
Outer	21.0 (0.827)	25.0 (0.984)
Inner	15.8 (0.622)	—

### Inspection and Adjustment

#### WHEEL ALIGNMENT (Unladen\*)

Camber	degree	-1°35' to -0°35'
Toe-in (Total)	mm (in)	0 - 4 (0 - 0.16)
	degree	0° - 22°

\* Fuel, radiator coolant and engine oil full.  
Spare tire, jack, hand tools and mats in designated positions.

#### WHEEL BEARING

Wheel bearing axial end play mm (in)	0.05 (0.0020) or less
Wheel bearing lock nut Tightening torque N·m (kg·m, ft·lb)	206 - 275 (21 - 28, 152 - 203)

#### WHEEL RUNOUT (Radial and lateral)

Wheel type	Radial runout	Lateral runout
Aluminum wheel	mm (in)	0.3 (0.012) or less

#### LOWER BALL JOINT

Swing force (Measuring point: cotter pin hole of ball stud)	N (kg, lb)	7.8 - 54.9 (0.8 - 5.6, 1.8 - 12.3)
Turning torque	N·m (kg·cm, in·lb)	0.5 - 3.4 (5 - 35, 4.3 - 30.4)
Vertical end play	mm (in)	0 (0)

#### LOWER LINK BALL JOINT (SUPER HICAS)

Swing force (at cotter pin hole)	N (kg, lb)	6.9 - 68.6 (0.7 - 7.0, 1.5 - 15.4)
Turning torque	N·m (kg·cm, in·lb)	0.3 - 2.9 (3 - 30, 2.6 - 25.0)
Vertical end play	mm (in)	0 (0)