

# PROPELLER SHAFT & DIFFERENTIAL CARRIER

GI

MA

EM

LC

EF &  
EC

FE

CL

MT

AT

PD

FA

RA

BR

ST

RS

BT

HA

EL

IDX

## SECTION PD

### CONTENTS

<b>PREPARATION</b> .....	2	<b>DISASSEMBLY</b> .....	14
Special Service Tools.....	2	Pre-inspection.....	14
Commercial Service Tools.....	5	Differential Carrier.....	14
<b>PROPELLER SHAFT</b> .....	6	Differential Case.....	16
On-vehicle Service.....	7	<b>INSPECTION</b> .....	17
Removal.....	7	Ring Gear and Drive Pinion.....	17
Installation.....	8	Bearing.....	17
Inspection.....	8	Differential Case Assembly.....	17
Disassembly.....	9	<b>ADJUSTMENT (R200V)</b> .....	18
Assembly.....	9	Side Bearing Preload.....	18
		Pinion Gear Height and Pinion Bearing Preload.....	19
		<b>ADJUSTMENT (R230V)</b> .....	24
		Side Bearing Preload.....	24
		Pinion Gear Height.....	25
		<b>ADJUSTMENT</b> .....	28
		Tooth Contact.....	28
		<b>ASSEMBLY</b> .....	29
		Differential Case.....	29
		Differential Carrier.....	30
		<b>SERVICE DATA AND SPECIFICATIONS (SDS)</b> .....	35
		Propeller Shaft.....	35
		Final Drive.....	35



<b>ON-VEHICLE SERVICE/REMOVAL AND INSTALLATION</b> .....	10
Front Oil Seal Replacement (R200V).....	10
Side Oil Seal Replacement.....	10
Removal.....	11
Installation.....	11
<b>FINAL DRIVE</b> .....	12
Model R200V.....	12
Model R230V.....	13

# PREPARATION

## Special Service Tools

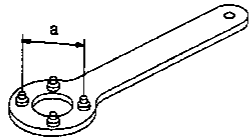
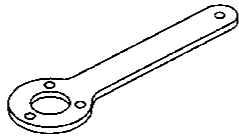
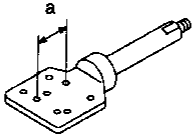
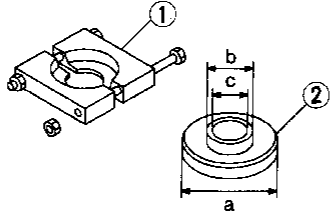
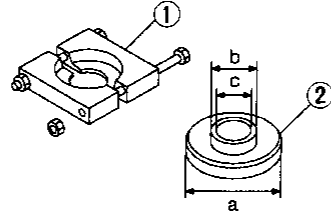
Tool number (Kent-Moore No.) Tool name	Description	Unit application		
		R200V	R230V	
ST38060002 (J34311) Drive pinion flange wrench	 <p>NT355</p>	Removing and installing propeller shaft lock nut, and drive pinion lock nut.	X	—
( — ) Drive pinion flange wrench	 <p>NT348</p>	Removing and installing propeller shaft lock nut, and drive pinion lock nut	—	X
KV38100800 ( — ) Equivalent tool (J25604-01) Differential attachment	 <p>NT119</p>	Mounting final drive (To use, make a new hole.)	X	X
ST3090S000 ( — ) Drive pinion rear inner race puller set ① ST30031000 (J22912-01) Puller ② ST30901000 ( — ) Equivalent tool (J26010-01) Base	 <p>NT527</p>	Removing and installing drive pinion rear cone	X	—
ST3002S000 ( — ) Drive pinion rear inner race puller set ① ST30021000 ( — ) Puller ② ST30022000 ( — ) Base	 <p>NT527</p>	Removing and installing drive pinion rear cone	—	X

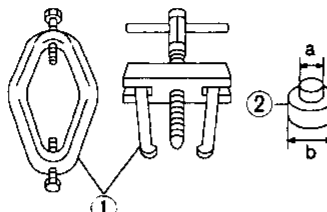
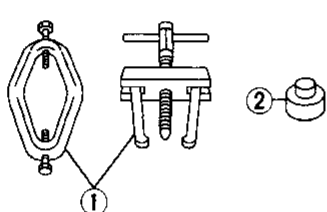
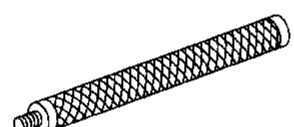
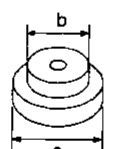
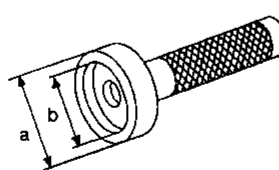
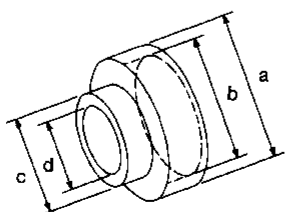

# PREPARATION

## Special Service Tools (Cont'd)

Tool number (Kent-Moore No.) Tool name	Description	Unit application		GI					
		R200V	R230V						
ST3306S001 ( — ) Differential side bearing puller set ① ST33051001 ( — ) Equivalent tool (J22888) Body ② ST33061000 (J8107-2) Equivalent tool (J26010-01) Adapter	 NT072  <b>a: 28.5 mm (1.122 in) dia.</b> <b>b: 38 mm (1.50 in) dia.</b>	Removing and installing differential side bearing inner cone	X	—	MA	EM	LC	EF & EC	FE
ST3306S001 ( — ) Differential side bearing puller set ① ST33051001 ( — ) Equivalent tool (J22888) Body ② ( — ) Adapter	 NT133	Removing and installing differential side bearing inner cone	—	X	CL	MT	AT	PD	
ST30611000 (J25742-1) Drift	 NT090	Installing pinion rear bearing outer race	X	X	FA	RA			
ST30613000 (J25742-3) Drift	 NT073  <b>a: 72 mm (2.83 in) dia.</b> <b>b: 48 mm (1.89 in) dia.</b>	Installing pinion front bearing outer race	X	—	BR	ST			
KV38100200 (J26233) Oil seal drift	 NT367  <b>a: 65 mm (2.56 in) dia.</b> <b>b: 49 mm (1.93 in) dia.</b>	Installing side oil seal	X	—	RS	BT			
KV38102510 ( — ) Oil seal drift	 NT476  <b>a: 71 mm (2.80 in) dia.</b> <b>b: 65 mm (2.56 in) dia.</b> <b>c: 55 mm (2.17 in) dia.</b> <b>d: 45 mm (1.77 in) dia.</b>	Installing side oil seal	—	X	HA	EL	IDX		

## PREPARATION

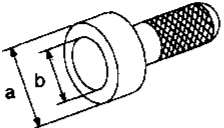
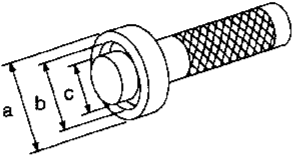
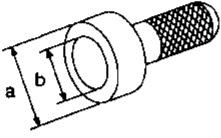
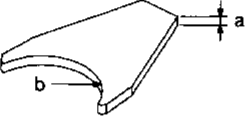
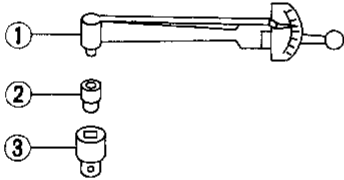
### Special Service Tools (Cont'd)

Tool number (Kent-Moore No.) Tool name	Description	Unit application			
		R200V	R230V		
KV38100500 ( — ) Oil seal drift	 <p>NT115</p>	Installing front oil seal	a: 85 mm (3.35 in) dia. b: 60 mm (2.36 in) dia.	X	—
KV38100300 (J25523) Drift	 <p>NT085</p>	Installing side bearing inner cone	a: 54 mm (2.13 in) dia. b: 46 mm (1.18 in) dia. c: 32 mm (1.26 in) dia.	X	—
( — ) Drift	 <p>NT115</p>	Installing side bearing inner cone	a: 64 mm (2.52 in) dia. b: 55.5 mm (2.185 in) dia.	—	X
KV38100600 (J25267) Side bearing spacer drift	 <p>NT528</p>	Installing side bearing spacer	a: 8 mm (0.31 in) b: R42.5 mm (1.673 in)	X	—
ST3127S000 (See J5765-A) Preload gauge ① GG91030000 (J25765) Torque wrench ② HT62940000 ( — ) Socket adapter ③ HT62900000 ( — ) Socket adapter	 <p>NT124</p>	Measuring pinion bearing preload and total preload		X	X
HT72400000 ( — ) Slide hammer	 <p>NT125</p>	Removing differential case assembly		X	X
(J34309) Differential shim selector	 <p>NT134</p>	Adjusting bearing preload and gear height		X	—

## PREPARATION

### Special Service Tools (Cont'd)

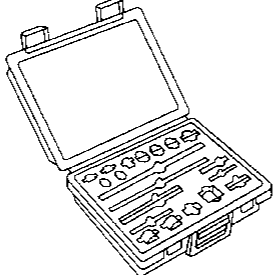
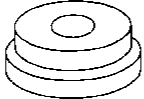
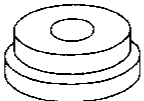
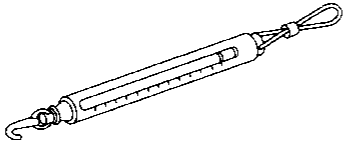
Tool number (Kent-Moore No.) Tool name	Description	Unit application		
		R200V	R230V	
( — ) Differential shim selector	 NT134	Adjusting bearing preload and gear height		
(J25269-4) Side bearing discs (2 Req'd)	 NT136	Selecting pinion height adjusting washer		
( — ) Side bearing discs (2 Req'd)	 NT136	Selecting pinion height adjusting washer		
(J8129) Spring gauge	 NT127	Measuring carrier turning torque		

G1

MA

EM

LC

EF &amp;

EC

FE

CL

MT

AT

PD

### Commercial Service Tools

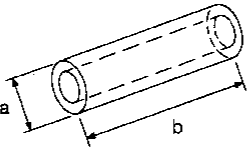
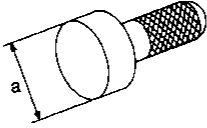
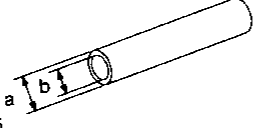
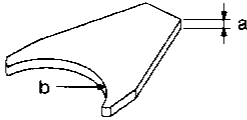
Tool name	Description	Unit application		
		R200V	R230V	
Drift	 NT131	Installing pinion rear bearing outer race		
Drift	 NT349	Installing pinion front bearing outer race		
Oil seal drift	 NT065	Installing front oil seal		
Side bearing spacer drift	 NT528	Installing side bearing spacer		

FA

RA

BR

ST

RS

BT

HA

EL

IDX

# PROPELLER SHAFT

3S71A

Washer  
Apply a coat of multi-purpose lithium grease containing molybdenum disulfide to the end face of the center bearing and both sides of the washer.

A/T model

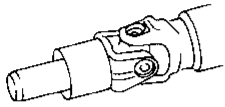

M/T model

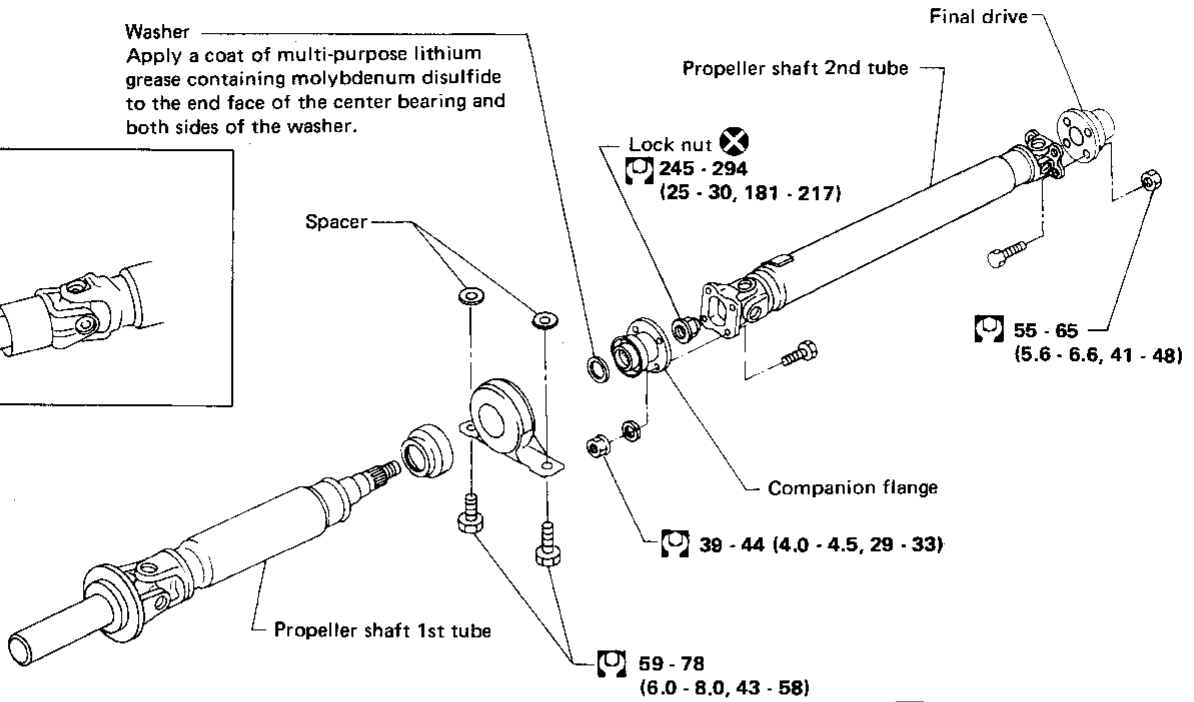

: N·m (kg·m, ft·lb)

SPD107A

3S80A-VL107

Washer  
Apply a coat of multi-purpose lithium grease containing molybdenum disulfide to the end face of the center bearing and both sides of the washer.

A/T model

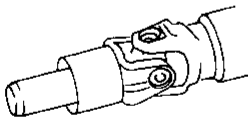

M/T model

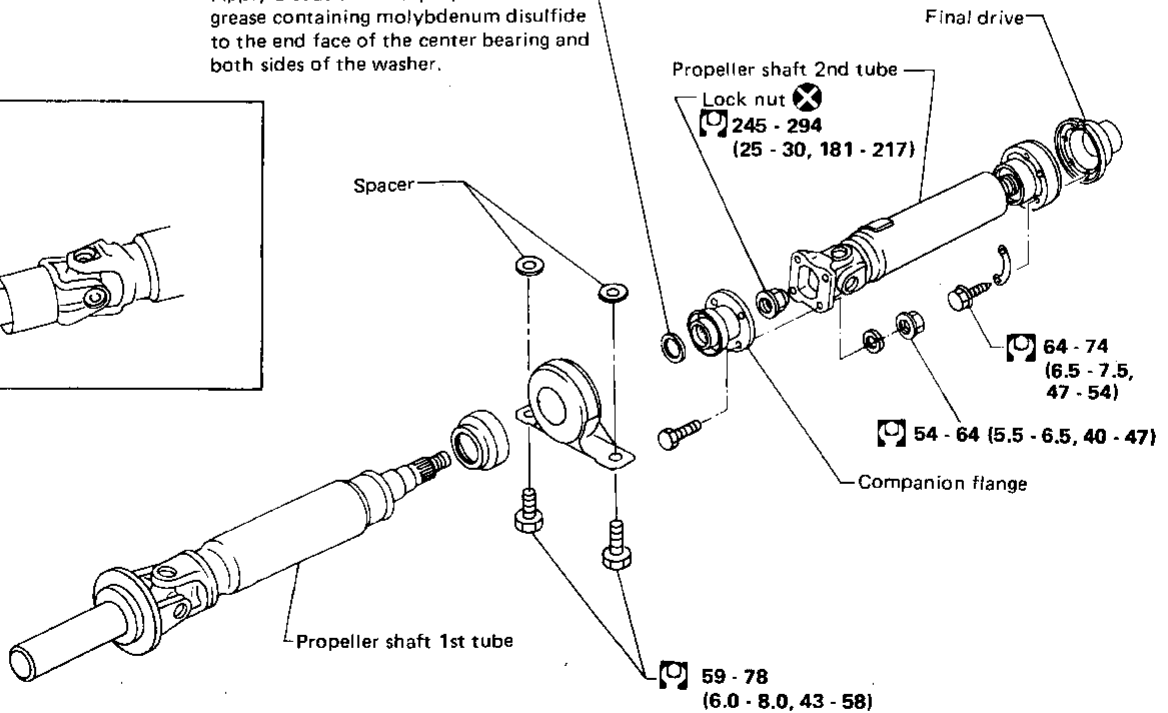

: N·m (kg·m, ft·lb)

SPD109A

# PROPELLER SHAFT

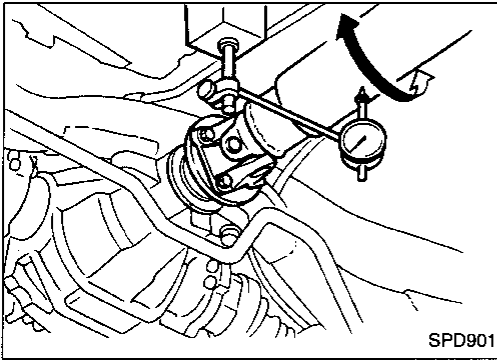

## On-vehicle Service

### PROPELLER SHAFT VIBRATION

If vibration is present at high speed, inspect propeller shaft runout first.

1. Raise rear wheels.
2. Measure propeller shaft runout at indicated points by rotating final drive companion flange with hands.

**Runout limit: 0.6 mm (0.024 in)**

GI

MA

EM

LC

EF &  
EC

FE

CL

MT

AT

PD

FA

RA

BR

ST

RS

BT

HA

EL

IDX

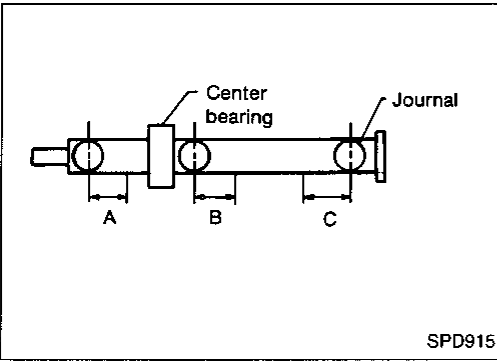

### Propeller shaft runout measuring points:

Distance "A":

162 mm (6.38 in)

Distance "B":

3S71A : 172 mm (6.77 in)

3S80A-VL107: 200 mm (7.87 in)

Distance "C":

3S71A : 192 mm (7.56 in)

3S80A-VL107: 200 mm (7.87 in)

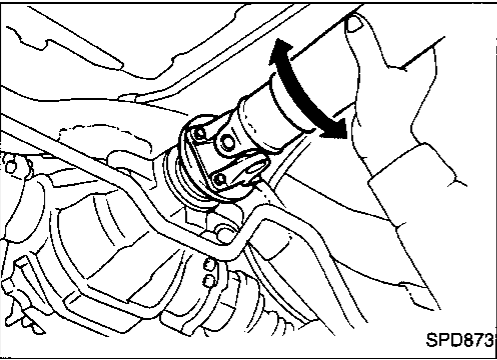

3. If runout exceeds specifications, disconnect propeller shaft at final drive companion flange. Rotate companion flange 90° (3S71A) or 60° (3S80A-VL107), and reconnect propeller shaft and check runout.

Repeat above operation when companion flange is rotated 180° (3S71A) or 120° (3S80A-VL107) and 270° (3S71A) or 180° (3S80A-VL107), respectively. Also, for 3S80A-VL107, the operation should be repeated at 240° and 300°. Securely connect propeller shaft at the point where the smallest runout of the three measurements occurs.

**Runout limit: 0.6 mm (0.024 in)**

4. Check runout again. If runout still exceeds specifications, replace propeller shaft assembly.
5. Perform road test.

### APPEARANCE CHECKING

- Inspect propeller shaft tube surface for dents or cracks. If damaged, replace propeller shaft assembly.
- If center bearing is noisy or damaged, replace center bearing.

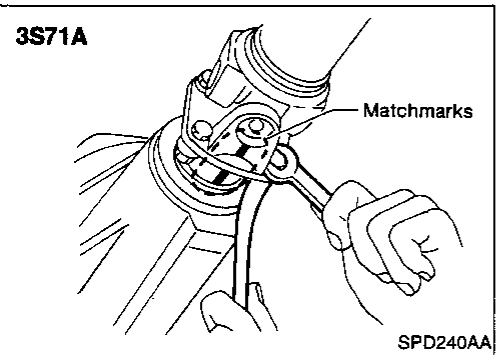

### Removal

- Put matchmarks on flanges and separate propeller shaft from final drive.

# PROPELLER SHAFT

## Removal (Cont'd)

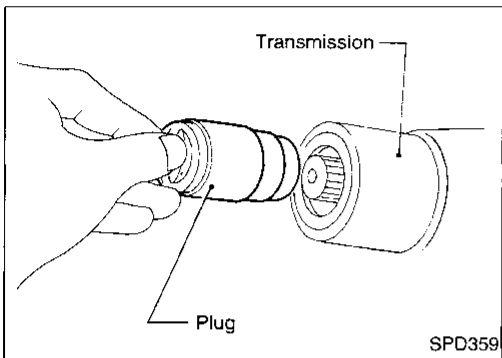
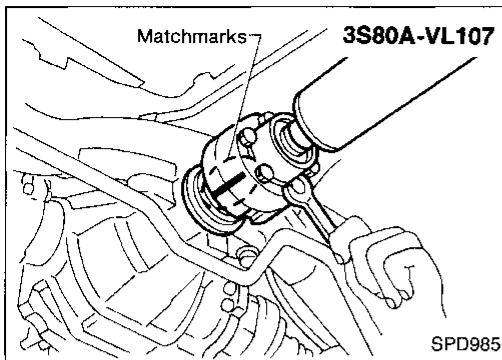

- Draw out propeller shaft from transmission and plug up rear end of transmission rear extension housing.

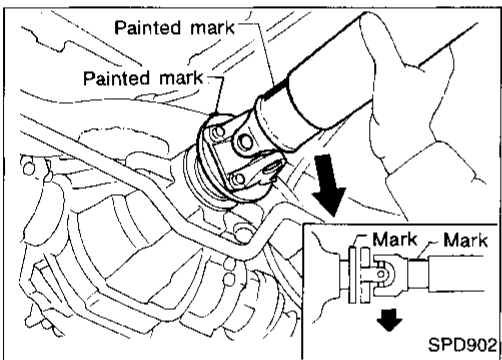

## Installation

- Temporarily install differential companion flange and flange yoke so that their alignment marks are located as close to each other as possible.
- Turn propeller shaft until alignment marks face straight upward. Securely fasten propeller shaft so that lower side wall of concave flange yoke will touch lower side wall of convex companion flange.

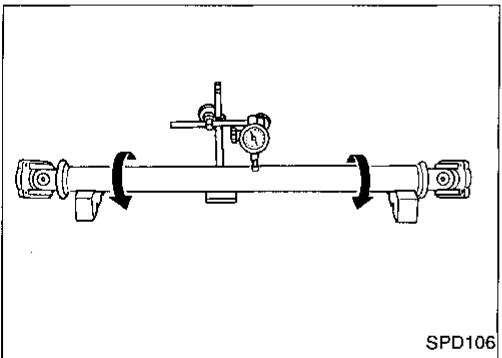

## Inspection

- Inspect propeller shaft runout. If runout exceeds specifications, replace propeller shaft assembly.

**Runout limit: 0.6 mm (0.024 in)**

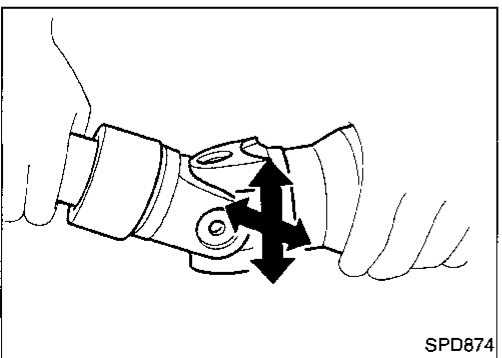

- Inspect journal axial play. If the play exceeds specifications, replace propeller shaft assembly.

**Journal axial play:  
0 mm (0 in)**



# PROPELLER SHAFT

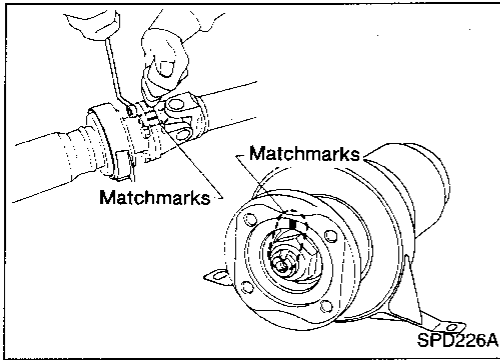

## Disassembly

### CENTER BEARING

1. Put matchmarks on flanges, and separate 2nd tube from 1st tube.
2. Put matchmarks on the flange and shaft.

GI

MA

EM

LC

EF &

EC

FE

CL

MT

AT

PD

FA

RA

BR

ST

RS

BT

HA

EL

IDX

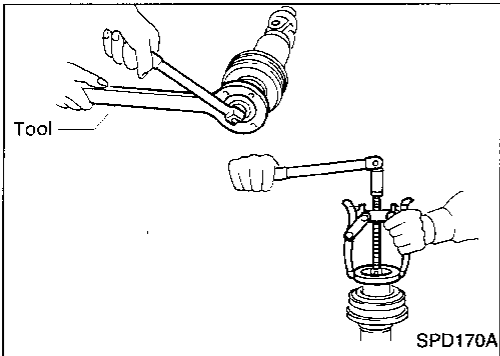

3. Remove locking nut with Tool.  
**Tool number: ST38060002 (J34311)**
4. Remove companion flange with puller.

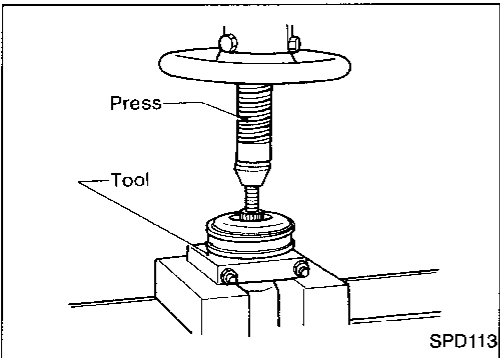

5. Remove center bearing with Tool and press.  
**Tool number: ST30031000 (J22912-01)**

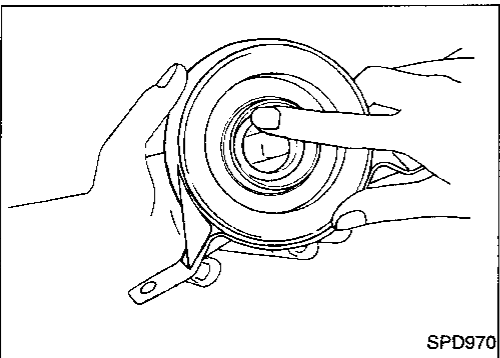

## Assembly

### CENTER BEARING

- Install center bearing with insulator's protrusion side facing front of vehicle.
- **Apply a coat of grease to the end face of center bearing and both sides of washer.**  
**Use multi-purpose lithium grease that contains molybdenum disulfide.**

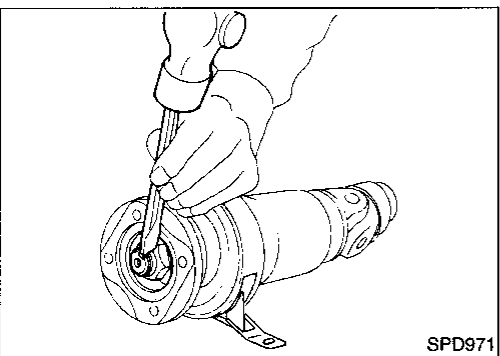

- Stake the nut. Always use new one.
- Align matchmarks when assembling tubes. Final drive

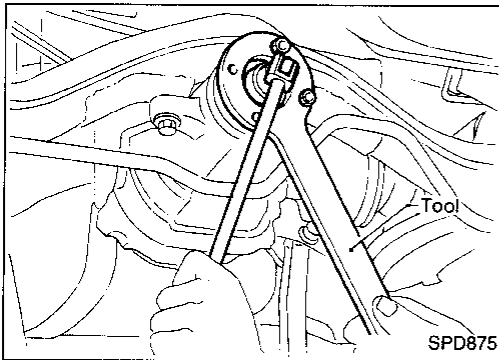

### Front Oil Seal Replacement (R200V)

**CAUTION:**

For final drive models using collapsible spacer (R230V), bearing preload must be adjusted whenever companion flange is removed. In order to do this adjustment correctly, final drive overhaul is required.

1. Remove propeller shaft.
2. Loosen drive pinion nut with Tool.  
 Tool number: **ST38060002 (J34311)**

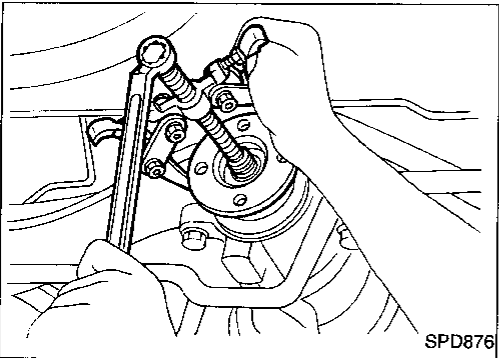

3. Remove companion flange.

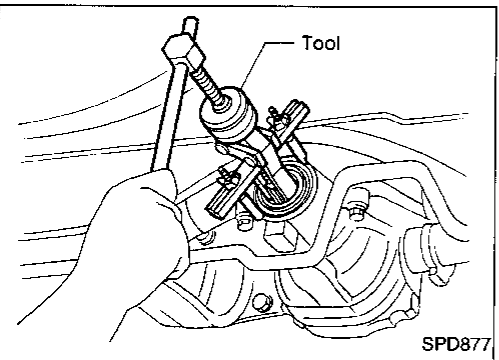

4. Remove front oil seal.

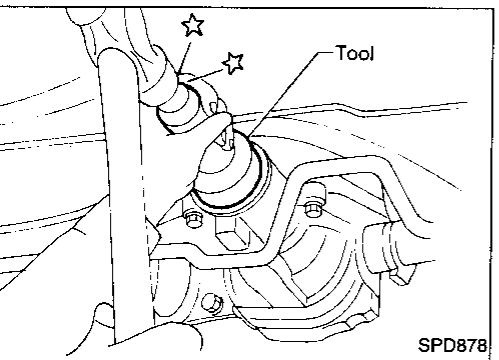

5. Apply multi-purpose grease to sealing lips of oil seal. Press front oil seal into carrier.
6. Install companion flange and drive pinion nut.
7. Install propeller shaft.

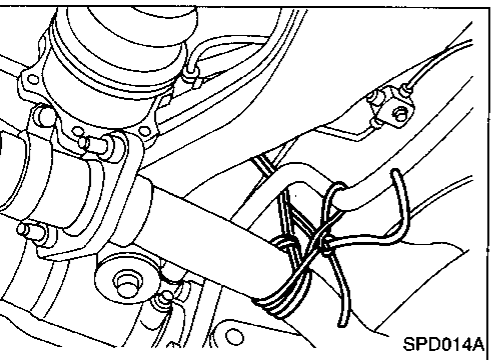

### Side Oil Seal Replacement

1. For LH side, remove drive shaft. For details, refer to "Drive Shaft" of REAR AXLE in RA section. For RH side, disconnect final drive side flange and drive shaft flange, and suspend drive shaft flange with wire.
2. Remove final drive side flange.
3. Remove oil seal.

Side Oil Seal Replacement (Cont'd)

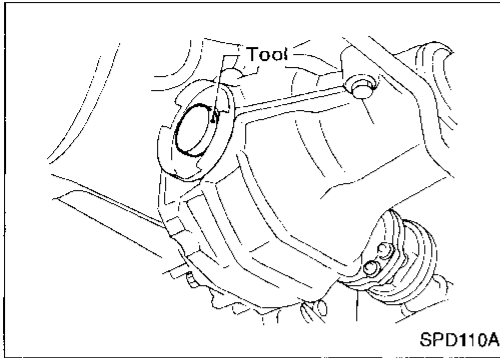

4. Apply multi-purpose grease to sealing lips of oil seal. Press-fit oil seal into carrier with Tool.

Tool number:  
KV38100200 (J26233) — R200V —  
( — ) — R230V —

GI

MA

EM

LC

EF &  
EC

FE

CL

MT

AT

PD

FA

RA

BR

ST

RS

BT

HA

EL

IDX

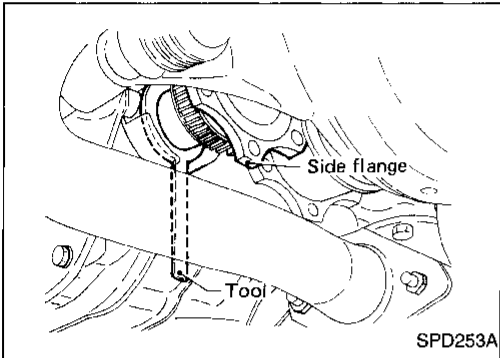

5. Install final drive side flange.

Use Tool to prevent side oil seal from being damaged by spline portion of side flange.

Tool number:  
KV38107900 (J39352) — R200V —  
KV38108000 (J39351) — R230V —

6. Install drive shaft.

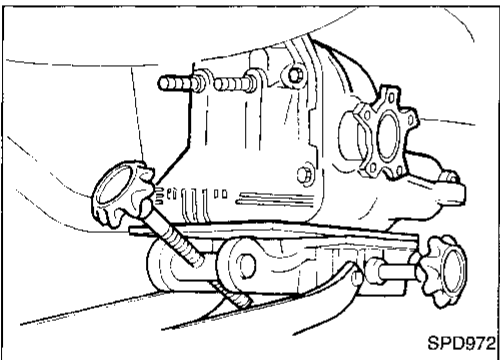

Removal

CAUTION:

Before removing the final drive assembly, disconnect the ABS sensor from the assembly. Then move it away from the final drive assembly. Failure to do so may result in damage to the sensor wires and the sensor becoming inoperative.

- Remove exhaust tube.
- Remove propeller shaft.

Plug up rear end of transmission rear extension housing.

- Remove drive shafts. Refer to "Drive Shaft" of "REAR AXLE" in RA section.
- Remove nuts securing final drive rear cove to suspension member.
- Support weight of final drive using jack.
- Remove final drive mounting member from front of final drive.
- Move final drive forward together with jack. Remove rear cover stud bolts from suspension member.
- Lower final drive using jack. Remove jack from rear of vehicle.

CAUTION:

- Be careful not to damage spline, sleeve yoke and front oil seal, when removing propeller shaft.
- After removal, support suspension member on a stand to prevent its insulators from being twisted or damaged.

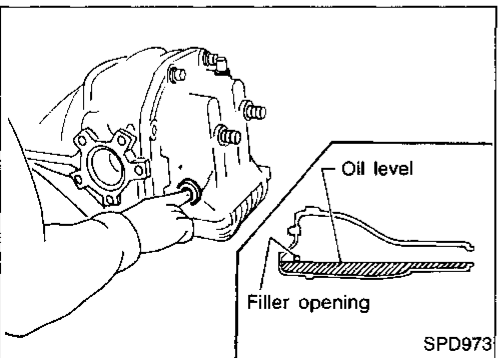

Installation

- Fill final drive with recommended gear oil.



# FINAL DRIVE

## Model R230V

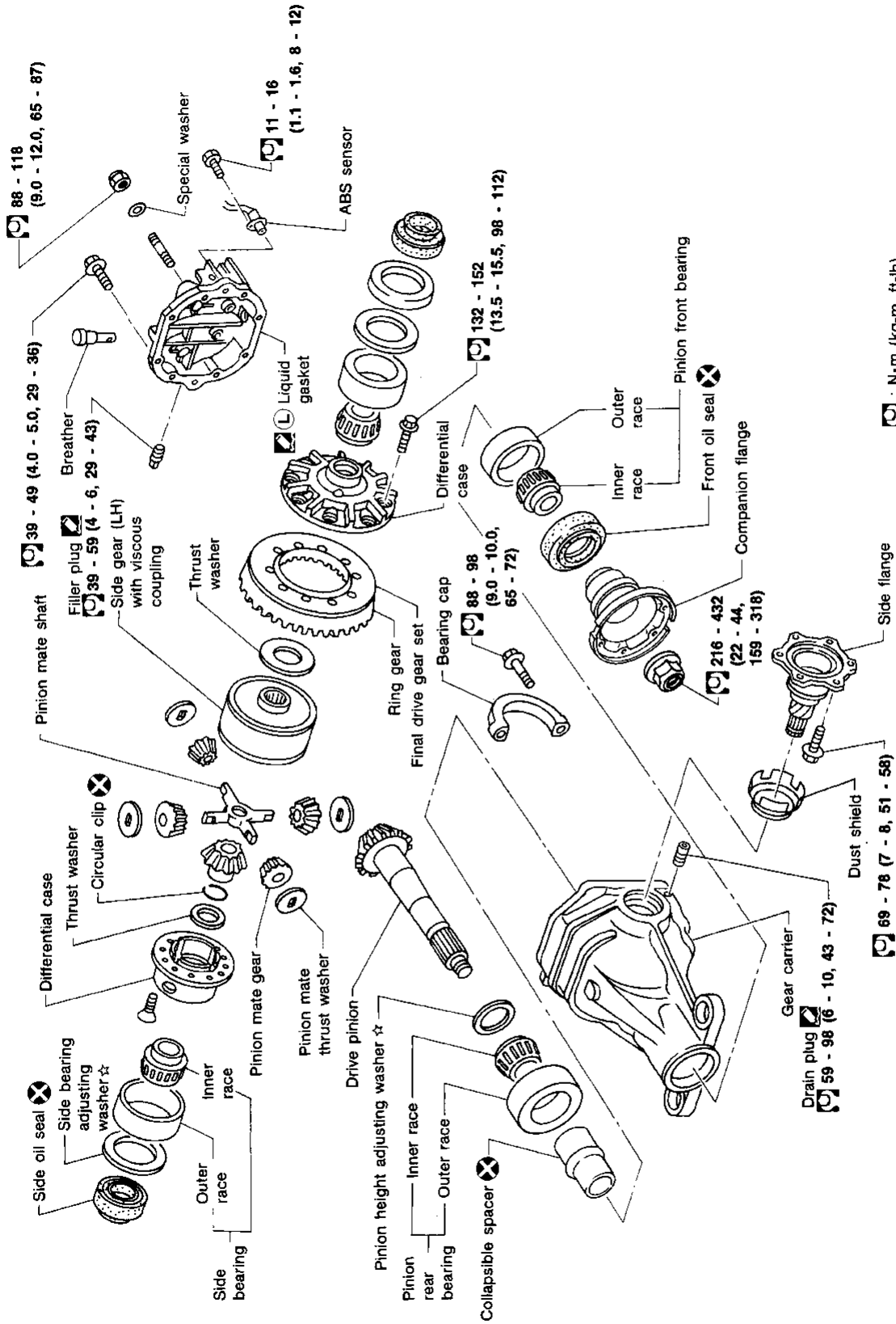

: N-m (kg-m, ft-lb)  
 : Apply recommended sealant (Nissan genuine part: KP610-00250) or equivalent.  
 : Using Genuine Liquid Gasket or equivalent.  
 : Adjustment is required.

- GI
- MA
- EM
- LC
- EF & EC
- FE
- CL
- MT
- AT
- PD**
- FA
- RA
- BR
- ST
- RS
- BT
- HA
- EL
- IDX

# DISASSEMBLY

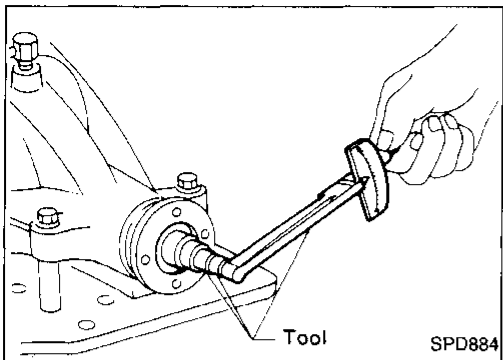

## Pre-inspection

Before disassembling final drive, perform the following inspection.

- Total preload
  - 1) Turn drive pinion in both directions several times to set bearing rollers.
  - 2) Check total preload with Tool.

**Tool number: ST3127S000 (J25765-A)**

**Total preload:**

**R200V 1.4 - 3.1 N·m (14 - 32 kg-cm, 12 - 28 in-lb)**

**R230V 2.1 - 4.1 N·m (21 - 42 kg-cm, 18 - 36 in-lb)**

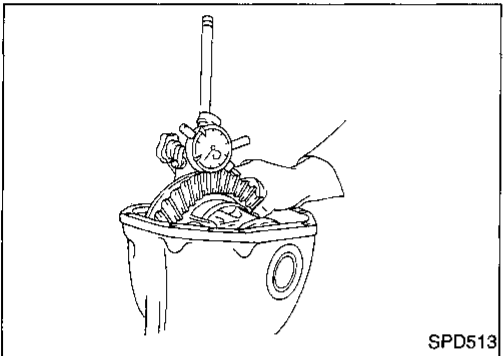

- Ring gear to drive pinion backlash  
Check ring gear to drive pinion backlash with a dial indicator at several points.

**Ring gear to drive pinion backlash:**

**R200V 0.10 - 0.15 mm (0.0039 - 0.0059 in)**

**R230V 0.13 - 0.18 mm (0.0051 - 0.0071 in)**

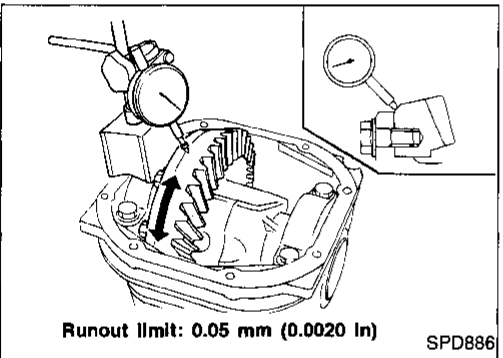

- Ring gear runout  
Check runout of ring gear with a dial indicator.  
**Runout limit: 0.05 mm (0.0020 in)**
- Tooth contact  
Check tooth contact. Refer to Adjustment (PD-28).

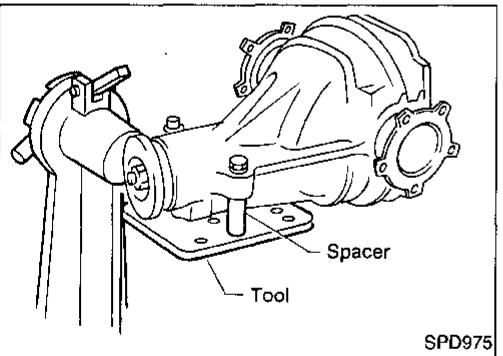

## Differential Carrier

1. Using two 45 mm (1.77 in) spacers, mount carrier on Tool.  
**Tool number: KV38100800 ( — )**

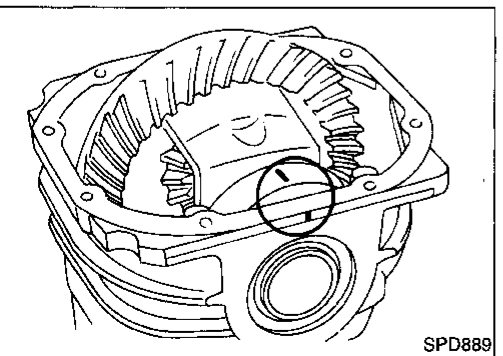

2. For proper reinstallation, paint or punch matchmarks on one side of the side bearing cap.

**Bearing caps are line-board during manufacture. Replace them in their proper positions.**

# DISASSEMBLY

## Differential Carrier (Cont'd)

3. Remove side bearing caps.

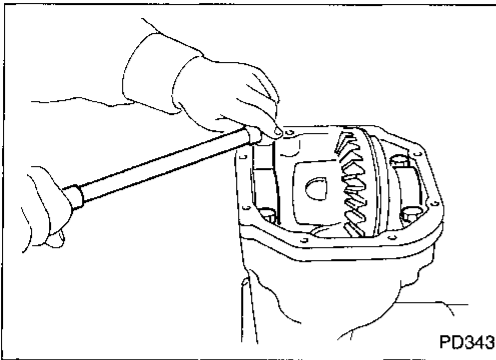

4. Lift differential case assembly out with Tool.  
Tool number: HT72400000 ( — )

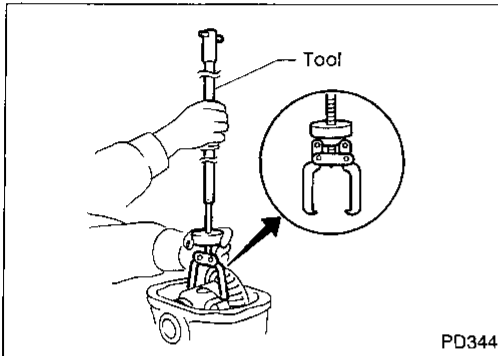

**Keep the side bearing outer races together with inner cone — do not mix them up.  
Also, keep side bearing spacer and adjusting shims together with bearings.**

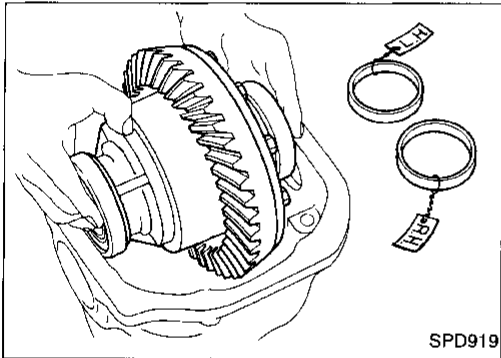

5. Loosen drive pinion nut and pull off companion flange.

**Tool number:**

**ST38060002 (J34311) — R200V —  
( — ) — R230V —**

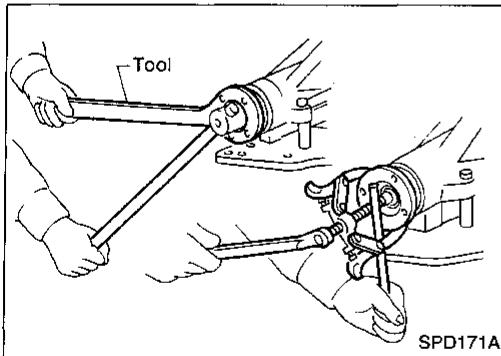

6. Take out drive pinion (together with rear bearing inner race, bearing spacer and adjusting washer).
7. Remove oil seal.
8. Remove front bearing inner race.
9. Remove side oil seal.

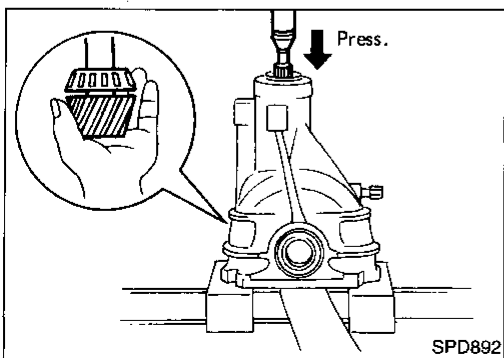

GI

MA

EM

LC

EF &  
EC

FE

CL

MT

AT

**PD**

FA

RA

BR

ST

RS

BT

HA

EL

IDX

## DISASSEMBLY

### Differential Carrier (Cont'd)

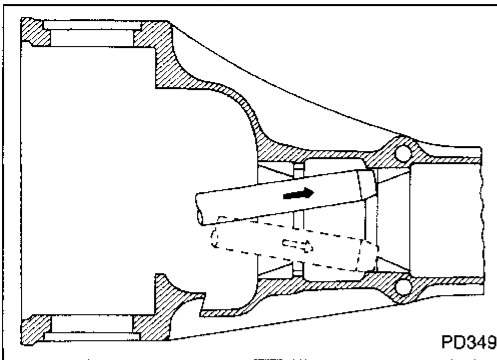

10. Remove pinion bearing outer races with a brass drift.

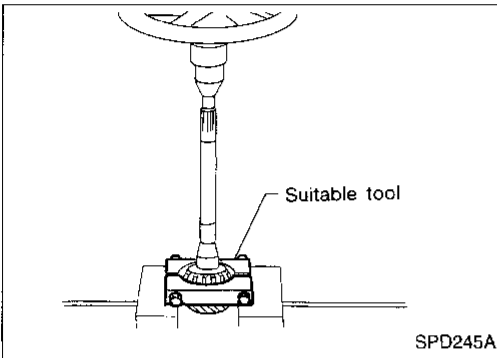

11. Remove pinion rear bearing inner race and drive pinion height adjusting washer with suitable tool.

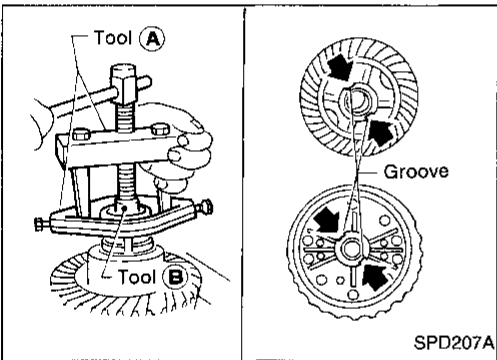

### Differential Case

1. Remove side bearing inner cones.

**To prevent damage to bearing, engage puller jaws in groove.**

**Tool number:**

- (A) ST33051001 ( — )
- (B) ST33061000 (J8107-2) — R200V —  
( — ) — R230V —

**Be careful not to mix up the left and right bearings.**

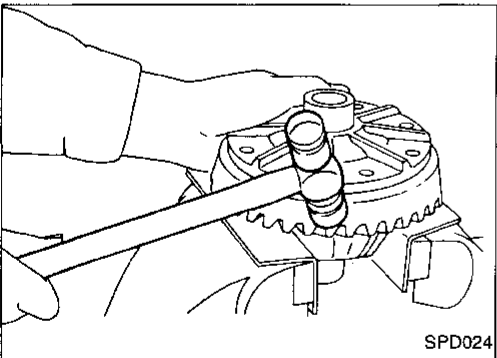

2. Loosen ring gear bolts in a criss-cross fashion.

3. Tap ring gear off the differential case with a soft hammer.

**Tap evenly all around to keep ring gear from binding.**

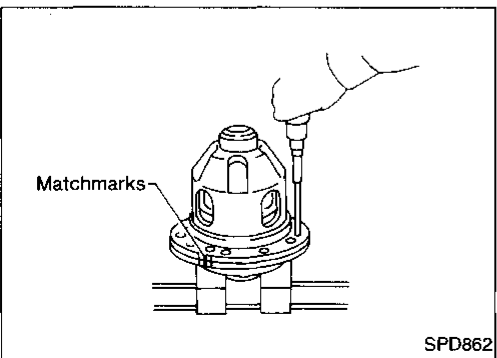

4. Loosen screws on differential cases A and B.

5. Separate differential cases A and B.

**CAUTION:**

**Assemble differential case firmly.**



# INSPECTION

## Ring Gear and Drive Pinion

Check gear teeth for scoring, cracking or chipping.  
If any damaged part is evident, replace ring gear and drive pinion as a set (hypoid gear set).

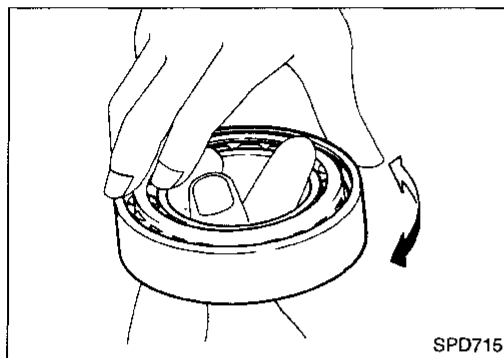

## Bearing

1. Thoroughly clean bearing.
2. Check bearings for wear, scratches, pitting or flaking. Check tapered roller bearing for smooth rotation. If damaged, replace outer race and inner cone as a set.

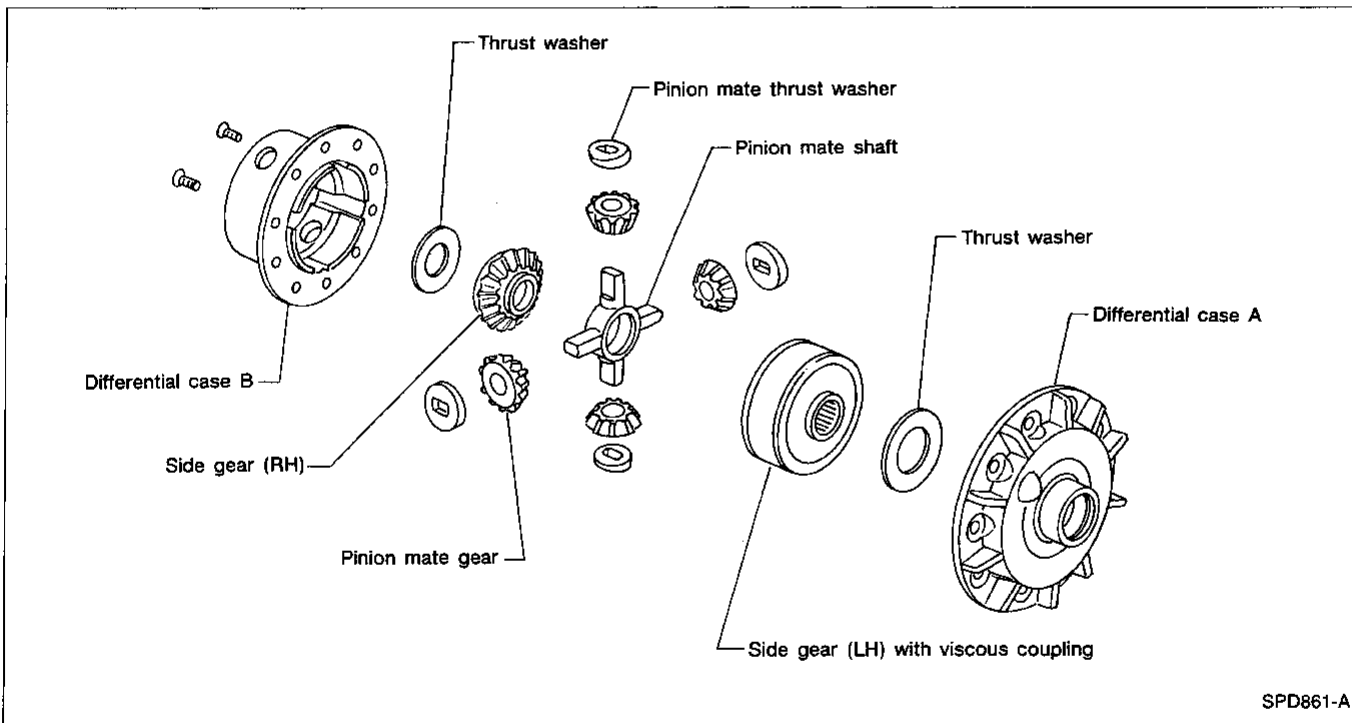

## Differential Case Assembly

Check mating surfaces of differential case, side gears, pinion mate gears, pinion mate shaft and thrust washers.

GI

MA

EM

LC

EF &  
EC

FE

CL

MT

AT

PD

FA

RA

BR

ST

RS

BT

HA

EL

IDX

## ADJUSTMENT (R200V)

For quiet and reliable final drive operation, the following five adjustments must be made correctly.

1. Side bearing preload
2. Pinion gear height
3. Pinion bearing preload
4. Ring gear to pinion backlash, refer to ASSEMBLY (PD-33).
5. Ring and pinion gear tooth contact pattern

### Side Bearing Preload

A selection of carrier side bearing preload shims is required for successful completion of this procedure.

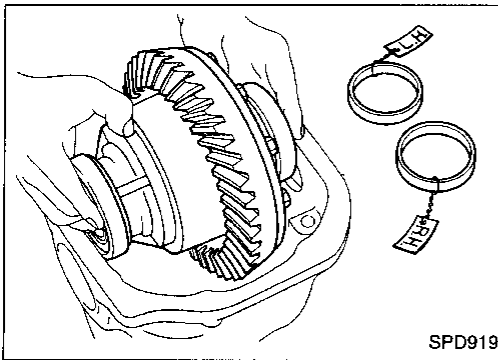

1. Make sure all parts are clean. Make sure, also, the bearings are well lubricated with light oil or DEXRON™II type automatic transmission fluid.
2. Place the differential carrier, with side bearings and bearing races installed, into the final drive housing.

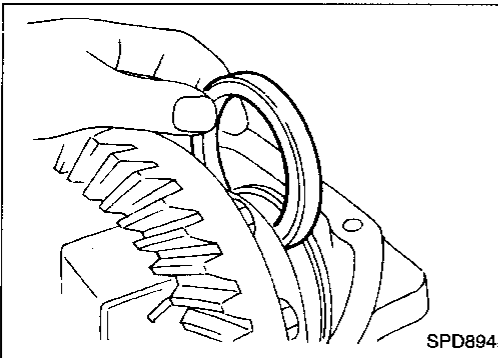

3. Put the side bearing spacer in place on the ring gear end of the carrier.

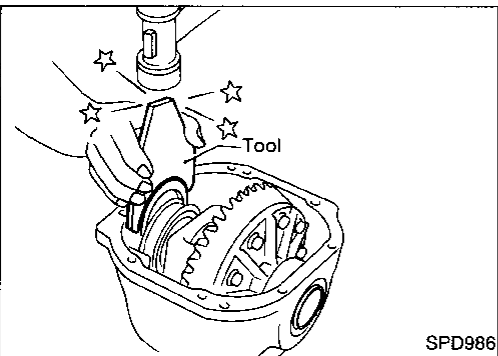

4. Use the J25267 side bearing spacer drift. Place original carrier side bearing preload shims on the carrier end, opposite the ring gear.

## ADJUSTMENT (R200V)

### Side Bearing Preload (Cont'd)

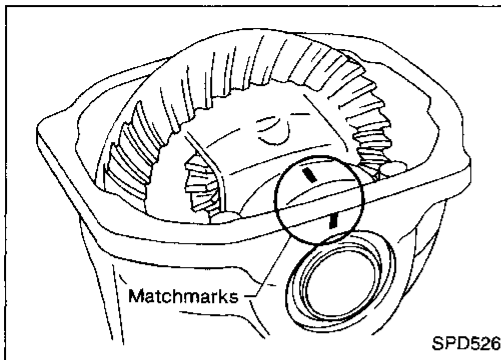

5. Install the side bearing caps in their correct locations and torque the bearing cap retaining bolts.

**Specification:**

88 - 98 N·m

(9 - 10 kg-m, 65 - 72 ft-lb)

6. Turn the carrier several times to seat the bearings.

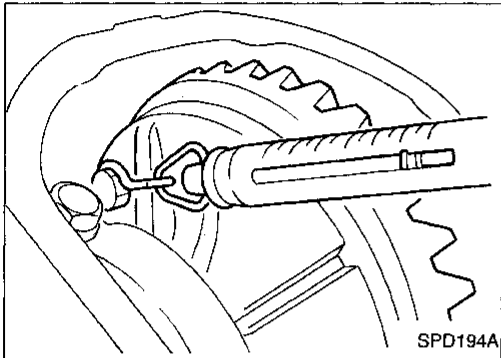

7. Measure the turning torque of the carrier at the ring gear retaining bolts with a spring gauge, J8129.

**Specification:**

34.3 - 39.2 N

(3.5 - 4 kg, 7.7 - 8.8 lb)

of pulling force at the ring gear bolt

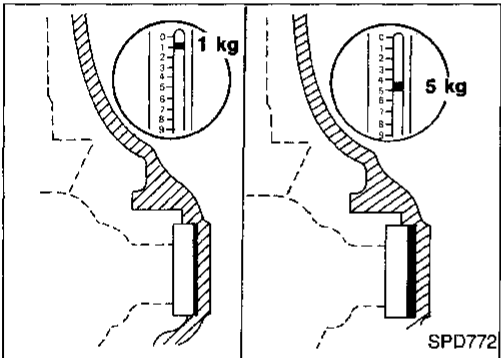

8. If the turning torque is not within the specifications correct the torque as follows:

- If the turning torque is less than the specified range, install washers of greater thickness.
  - If the turning torque is greater than the specification, install thinner washers.
  - See the SDS section for washer dimensions and part numbers.
9. Record the total amount of washer thickness required for the correct carrier side bearing preload.

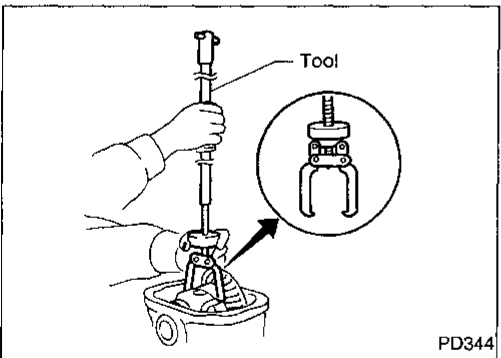

10. Remove the carrier from the final drive housing. Save the selected preload washers for later use during the assembly of the final drive unit.

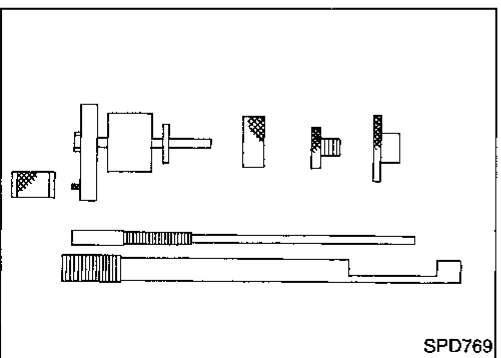

### Pinion Gear Height and Pinion Bearing Preload

1. Make sure all parts are clean and that the bearings are well lubricated.
2. Assemble the pinion gear bearings into the pinion preload shim selector Tool, J34309.

GI

MA

EM

LC

EF &

EC

FE

CL

MT

AT

PD

FA

RA

BR

ST

RS

BT

HA

EL

IDX

## ADJUSTMENT (R200V)

### Pinion Gear Height and Pinion Bearing Preload (Cont'd)

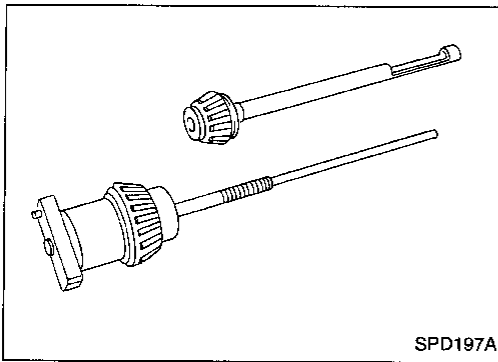

- **Front pinion bearing** — make sure the J34309-3 front pinion bearing seat is secured tightly against the J34309-2 gauge anvil. Then turn the front pinion bearing pilot, J34309-5, to secure the bearing in its proper position.
- **Rear pinion bearing** — the rear pinion bearing pilot, J34309-8, is used to center the rear pinion bearing only. The rear pinion bearing locking seat, J34309-4, is used to lock the bearing to the assembly.
- **Installation of J34309-9 and J34309-16** — place a suitable 2.5 mm (0.098 in) thick plain washer between J34309-9 and J34309-16. Both surfaces of J34309-9 and J34309-16 must be parallel with a clearance of 2.5 mm (0.098 in).

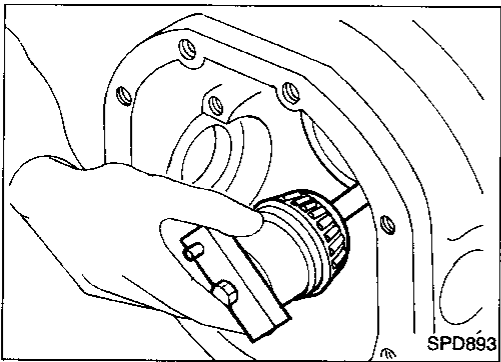

3. Install the pinion rear bearing inner cone into the final drive housing. Then place the pinion preload shim selector Tool, J34309-1, gauge screw assembly.

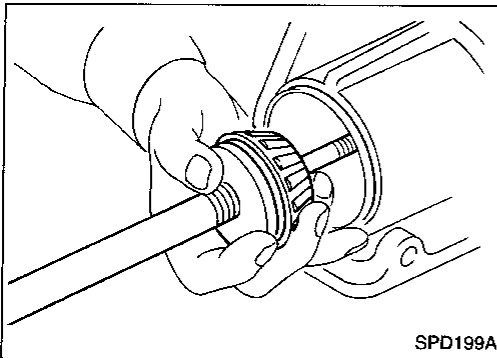

4. Assemble the front pinion bearing inner cone and the J34309-2 gauge anvil. Assemble them together with the J34309-1 gauge screw in the final drive housing. Make sure that the pinion height gauge plate, J34309-16, will turn a full 360 degrees. Tighten the two sections together by hand.

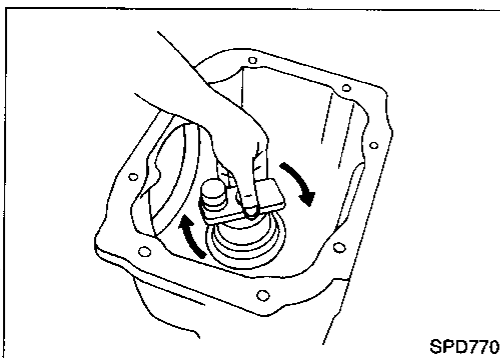

5. Turn the assembly several times to seat the bearings.

## ADJUSTMENT (R200V)

### Pinion Gear Height and Pinion Bearing Preload (Cont'd)

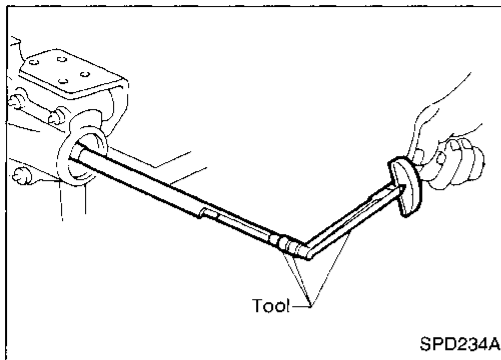

6. Measure the turning torque at the end of the J34309-2 gauge anvil using torque wrench J25765A.

**Turning torque specification:**

1.0 - 1.3 N·m

(10 - 13 kg-cm, 8.7 - 11.3 in-lb)

GI

MA

EM

LC

EF &

EC

FE

CL

MT

AT

PD

FA

RA

BR

ST

RS

BT

HA

EL

IDX

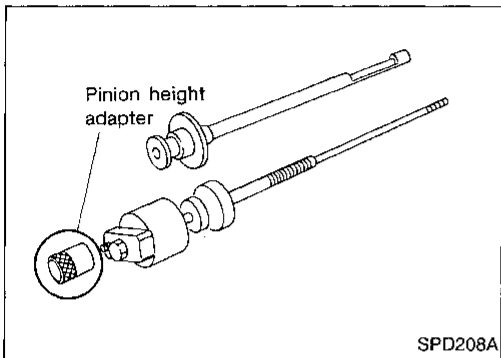

7. Place the J34309-11 "R200A" pinion height adapter onto the gauge plate and tighten it by hand.

**CAUTION:**

**Make sure all machined surfaces are clean.**

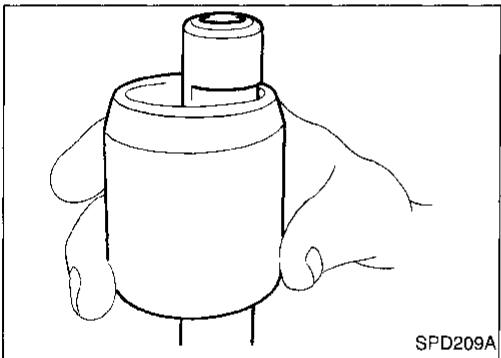

### — PINION BEARING PRELOAD WASHER SELECTION —

8. Place the solid pinion bearing spacer, small end first, over the J34309-2 gauge anvil. Seat the small end squarely against the tip of the J34309-1 gauge screw in the tool recessed portion.

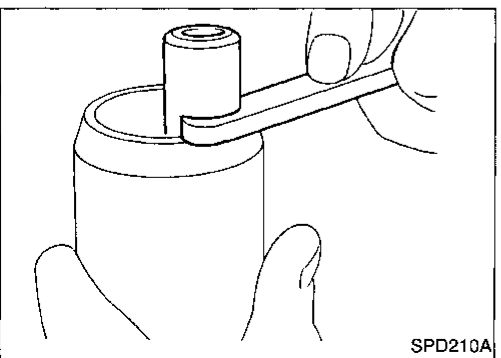
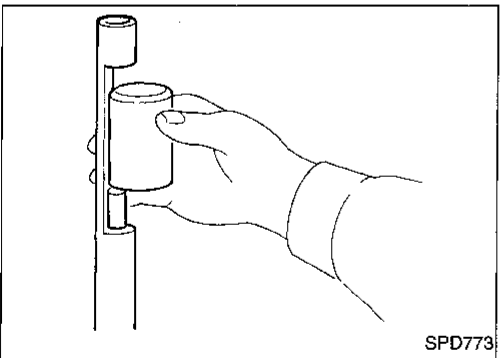

9. Select the correct thickness of pinion bearing preload adjusting washer. Select by using a standard gauge of 3.5 mm (0.138 in) and your J34309-101 feeler gauge. The exact measure you get with your gauges is the thickness of the adjusting washer required. Select the correct washer from the following chart.

**Drive pinion bearing preload adjusting washer:**

**Refer to SDS (PD-36).**

## ADJUSTMENT (R200V)

### Pinion Gear Height and Pinion Bearing Preload (Cont'd)

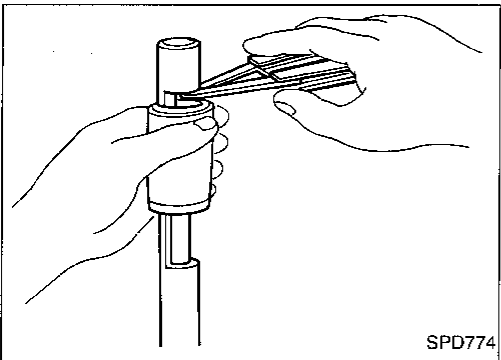

10. Set aside the selected correct pinion bearing preload adjusting washer. Use it when assembling the pinion gear and bearing into the final drive.

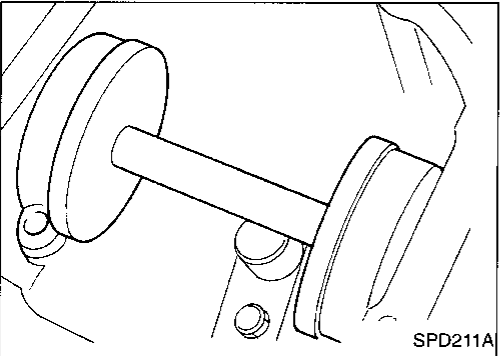

#### — PINION HEIGHT ADJUSTING WASHER SELECTION —

11. Now, position the side bearing discs, J25269-4, and arbor firmly into the side bearing bores. Install the side bearing caps and tighten the cap bolts to proper torque.

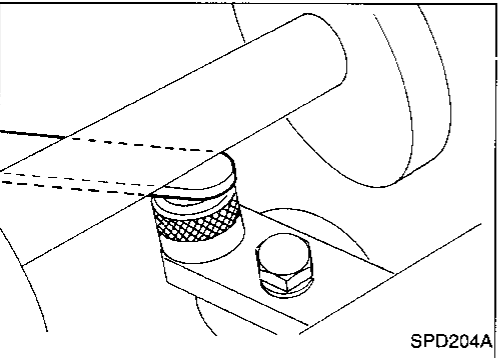

12. Select the correct standard pinion height adjusting washer thickness. Select by using a standard gauge of 3 mm (0.12 in) and your J34309-101 feeler gauge. Measure the distance between the J34309-11 pinion height adapter including the standard gauge and the arbor.

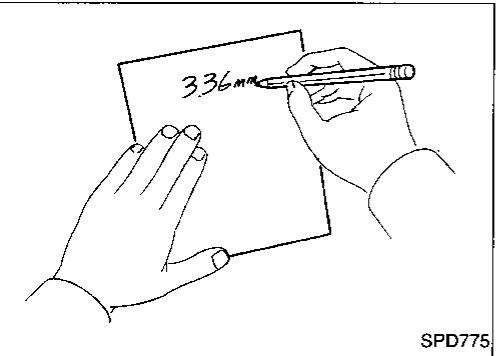

13. Write down your exact measurement (the value of feeler gauge).

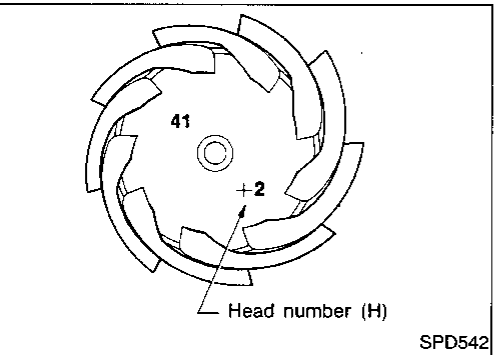

14. Correct the pinion height washer size by referring to the "pinion head number."

There are two numbers painted on the pinion gear. The first one refers to the pinion and ring gear as a matched set. This number should be the same as the number on the ring gear. The second number is the "pinion head height number". It refers to the ideal pinion height from standard for quietest operation. Use the following chart to determine the correct pinion height washer.

## ADJUSTMENT (R200V)

### Pinion Gear Height and Pinion Bearing Preload (Cont'd)

Pinion head height number	Add or remove from the standard pinion height washer thickness measurement
-6	Add 0.06 mm (0.0024 in)
-5	Add 0.05 mm (0.0020 in)
-4	Add 0.04 mm (0.0016 in)
-3	Add 0.03 mm (0.0012 in)
-2	Add 0.02 mm (0.0008 in)
-1	Add 0.01 mm (0.0004 in)
0	Use the selected washer thickness
+1	Subtract 0.01 mm (0.0004 in)
+2	Subtract 0.02 mm (0.0008 in)
+3	Subtract 0.03 mm (0.0012 in)
+4	Subtract 0.04 mm (0.0016 in)
+5	Subtract 0.05 mm (0.0020 in)
+6	Subtract 0.06 mm (0.0024 in)

15. Select the correct pinion height washer from the following chart.

**Drive pinion height adjusting washer:  
Refer to SDS (PD-36).**

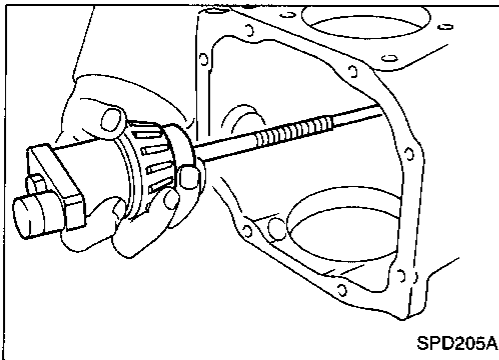

16. Remove the J34309 pinion preload shim selector Tool from the final drive housing. Then disassemble to retrieve the pinion bearings.

## ADJUSTMENT (R230V)

For quiet and reliable final drive operation, the following five adjustments must be made correctly.

1. Side bearing preload
2. Pinion gear height
3. Ring gear to pinion backlash, refer to ASSEMBLY (PD-33).
4. Ring and pinion gear tooth contact pattern

### Side Bearing Preload

A selection of carrier side bearing preload shims is required for successful completion of this procedure.

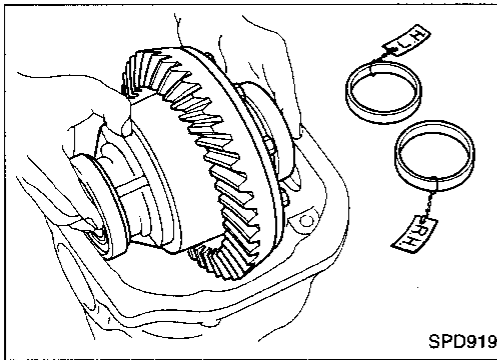

1. Make sure all parts are clean. Make sure, also, the bearings are well lubricated with light oil or DEXRON™II type automatic transmission fluid.
2. Place the differential carrier, with side bearings and bearing races installed, into the final drive housing.

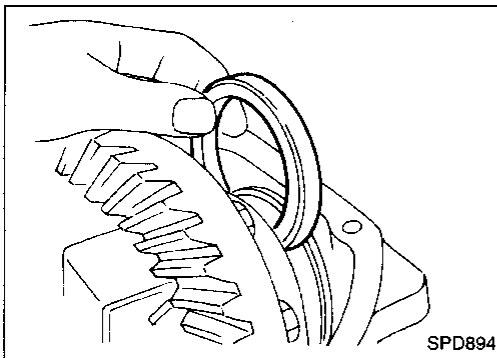

3. Put the side bearing spacer in place on the ring gear end of the carrier.

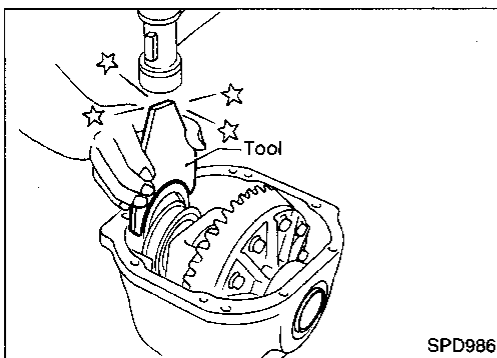

4. Use the ( — ) side bearing spacer drift. Place original carrier side bearing preload shims on the carrier end, opposite the ring gear.



## ADJUSTMENT (R230V)

### Side Bearing Preload (Cont'd)

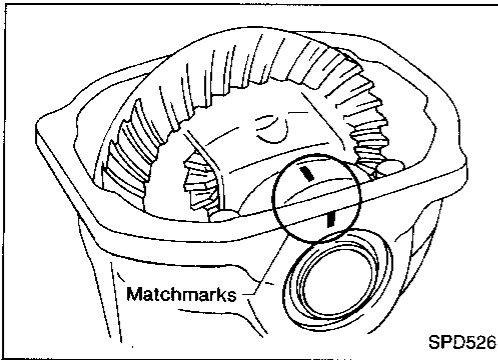

5. Install the side bearing caps in their correct locations and torque the bearing cap retaining bolts.

**Specification:**

**88 - 98 N·m**

**(9 - 10 kg·m, 65 - 72 ft·lb)**

6. Turn the carrier several times to seat the bearings.

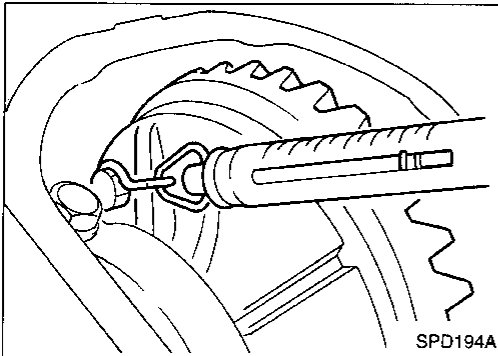

7. Measure the turning torque of the carrier at the ring gear retaining bolts with a spring gauge, J8129.

**Specification:**

**34.3 - 39.2 N**

**(3.5 - 4 kg, 7.7 - 8.8 lb)**

**of pulling force at the ring gear bolt**

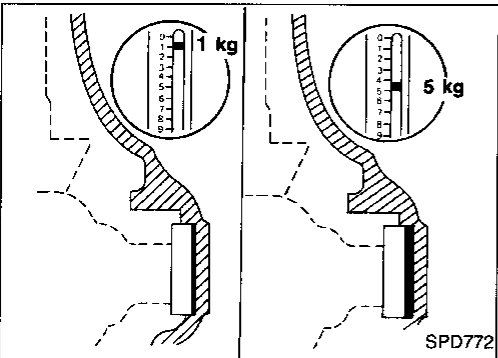

8. If the turning torque is not within the specifications correct the torque as follows:

- If the turning torque is less than the specified range, install washers of greater thickness.
  - If the turning torque is greater than the specification, install thinner washers.
9. Record the total amount of washer thickness required for the correct carrier side bearing preload.

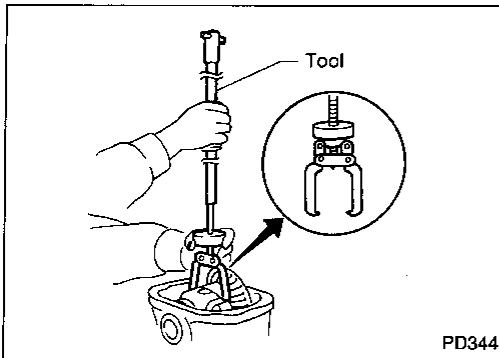

10. Remove the carrier from the final drive housing. Save the selected preload washers for later use during the assembly of the final drive unit.

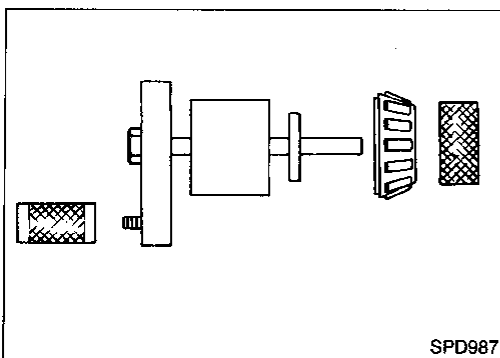

### Pinion Gear Height

1. Make sure all parts are clean and that the bearings are well lubricated.
2. Assemble the pinion gear bearings into the pinion preload shim selector Tool, ( — ).

GI

MA

EM

LC

EF &

EC

FE

CL

MT

AT

PD

FA

RA

BR

ST

RS

BT

HA

EL

IDX

## ADJUSTMENT (R230V)

### Pinion Gear Height (Cont'd)

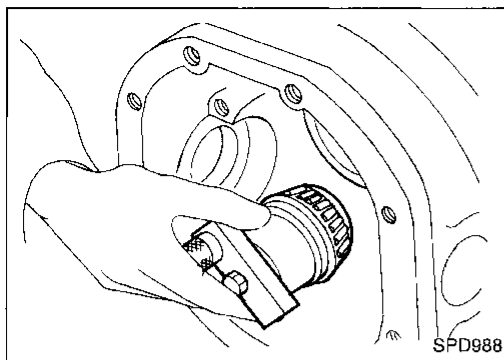

3. Install the pinion rear bearing inner cone into the final drive housing. Then place the pinion preload shim selector Tool, ( — ), gauge screw assembly.

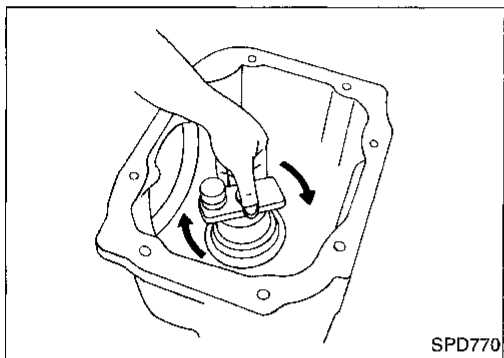

4. Turn the assembly several times to seat the bearings.

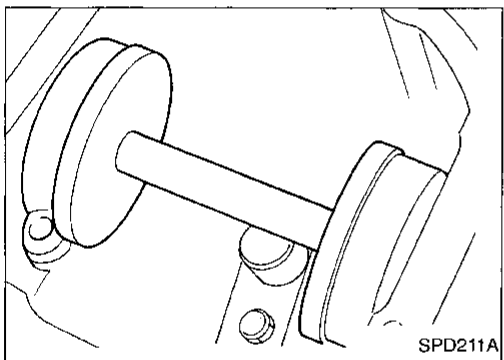

5. Now, position the side bearing discs, ( — ), and arbor firmly into the side bearing bores. Install the side bearing caps and tighten the cap bolts to proper torque.

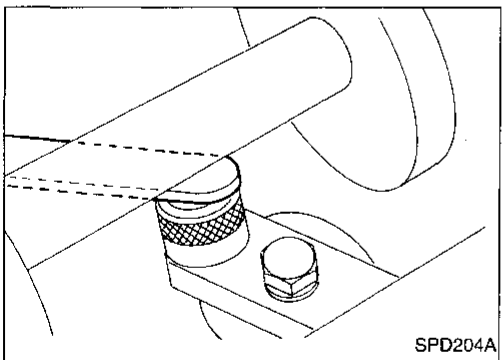

6. Select the correct standard pinion height adjusting washer thickness. Select by using a standard gauge of 3 mm (0.12 in) and your ( — ) feeler gauge. Measure the distance between the ( — ) pinion height adapter including the standard gauge and the arbor.

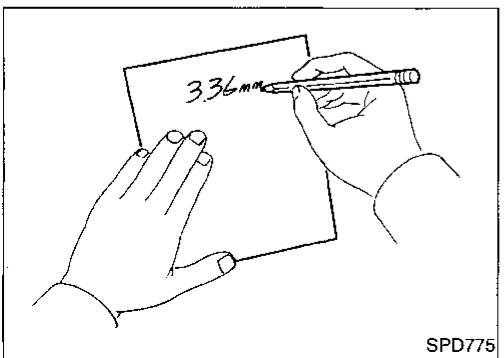

7. Write down your exact measurement (the value of feeler gauge).

## ADJUSTMENT (R230V)

### Pinion Gear Height (Cont'd)

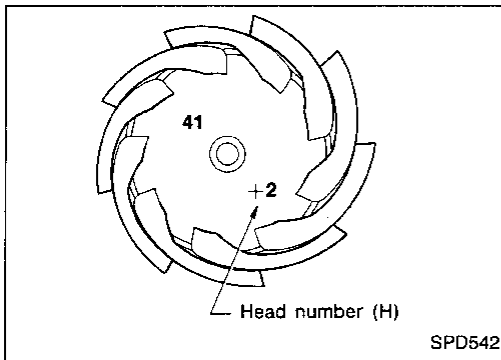

8. Correct the pinion height washer size by referring to the “pinion head number”.

There are two numbers painted on the pinion gear. The first one refers to the pinion and ring gear as a matched set. This number should be the same as the number on the ring gear. The second number is the “pinion head height number”. It refers to the ideal pinion height from standard for quietest operation. Use the following chart to determine the correct pinion height washer.

Pinion head height number	Add or remove from the standard pinion height washer thickness measurement
-6	Add 0.06 mm (0.0024 in)
-5	Add 0.05 mm (0.0020 in)
-4	Add 0.04 mm (0.0016 in)
-3	Add 0.03 mm (0.0012 in)
-2	Add 0.02 mm (0.0008 in)
-1	Add 0.01 mm (0.0004 in)
0	Use the selected washer thickness
+1	Subtract 0.01 mm (0.0004 in)
+2	Subtract 0.02 mm (0.0008 in)
+3	Subtract 0.03 mm (0.0012 in)
+4	Subtract 0.04 mm (0.0016 in)
+5	Subtract 0.05 mm (0.0020 in)
+6	Subtract 0.06 mm (0.0024 in)

9. Select the correct pinion height washer from the following chart.

**Drive pinion height adjusting washer:  
Refer to SDS (PD-37).**

GI  
MA  
EM  
LC  
EF & EC  
FE  
CL  
MT  
AT  
PD  
FA  
RA  
BR  
ST  
RS  
BT  
HA  
EL  
IDX

# ADJUSTMENT

## Tooth Contact

Checking gear tooth contact pattern is necessary to verify correct relationship between ring gear and drive pinion. Hypoid gears which are not positioned in proper arrangement may be noisy and/or have a short life. Check gear tooth contact pattern to obtain the best contact for low noise and long life.

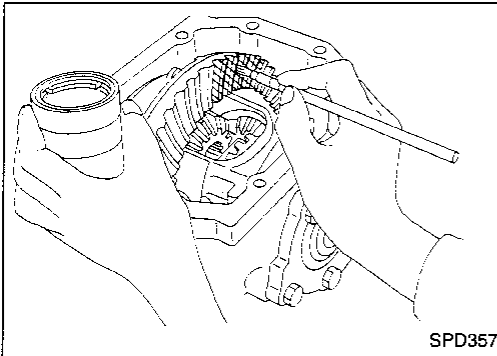

1. Thoroughly clean ring gear and drive pinion teeth.
2. Lightly apply a mixture of powdered titanium oxide and oil or the equivalent. Apply it to 3 or 4 teeth of ring gear drive side.

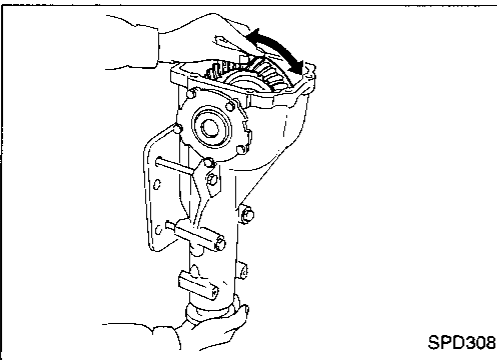

3. Hold companion flange steady by hand and rotate the ring gear in both directions.

Usually the pattern will be correct if shims are correctly calculated and the backlash is correct. However, in rare cases, trial and error processes may be employed to obtain a correct pattern. The tooth pattern is the best indication of how well a differential has been set up.

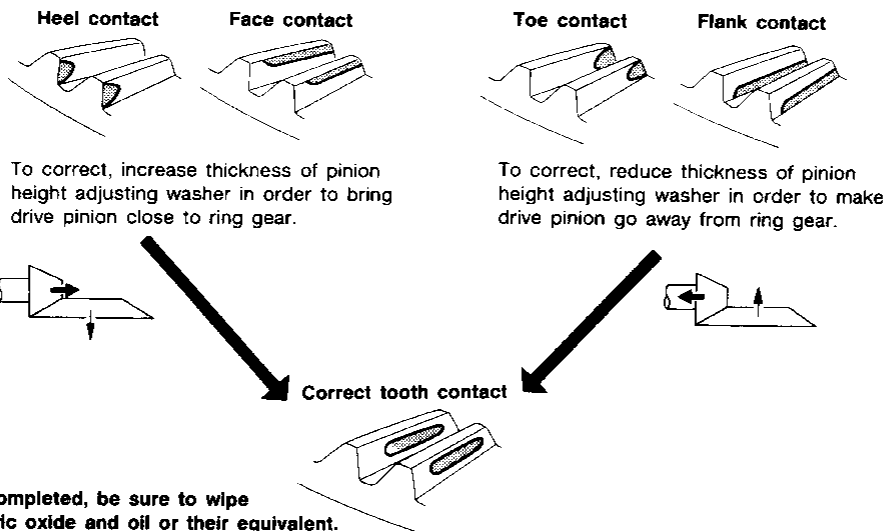

SPD007-B



## Differential Carrier

1. Press-fit front and rear bearing outer races with Tools.

**Tool number:**

- Ⓐ Suitable tool
- Ⓑ ST30611000 (J25742-1)
- Ⓒ ST30613000 (J25742-3) — R200V —  
( — ) — R230V —

2. Select pinion bearing adjusting washer and drive pinion bearing spacer. Refer to ADJUSTMENT (PD-19).

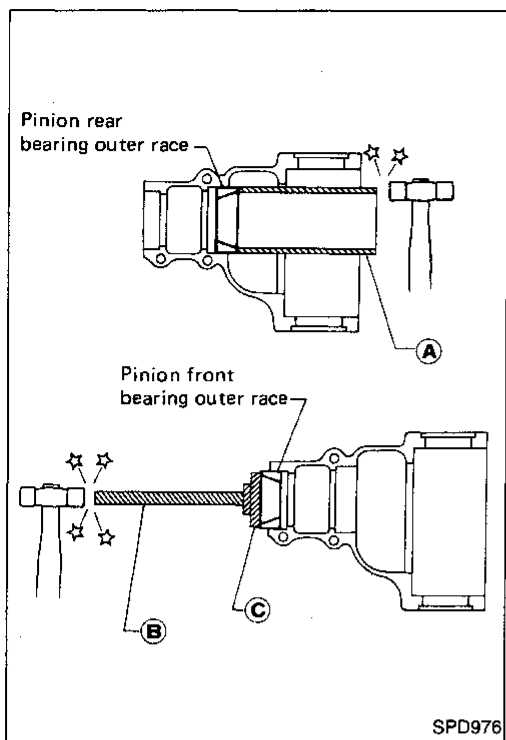

3. Install selected drive pinion height adjusting washer in drive pinion. Using press and Tool, press-fit pinion rear bearing inner cone into it.

**Tool number:**

- ST30901000 ( — ) — R200V —
- ST30022000 ( — ) — R230V —

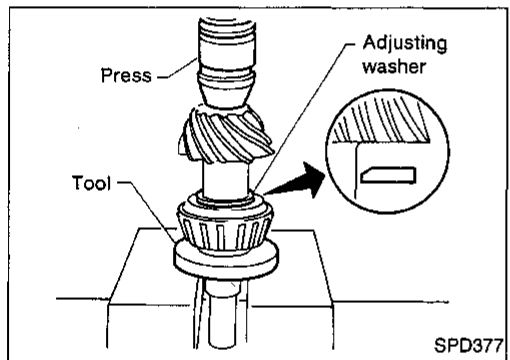

4. Place pinion front bearing inner cone in final drive housing.

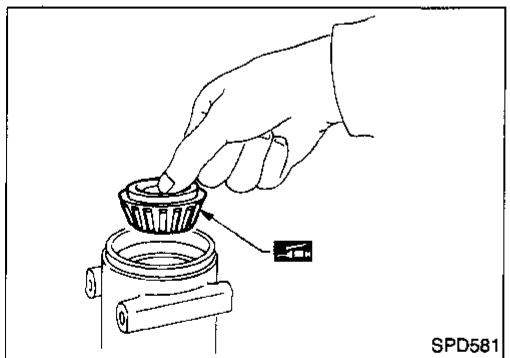

5. Set drive pinion assembly (as shown in figure at left) in differential carrier and install drive pinion, with press and suitable tool.

**Stop when drive pinion touches bearing.**

**Apply multi-purpose grease to pinion rear bearing inner race, pinion front bearing inner race and front pilot bearing.**

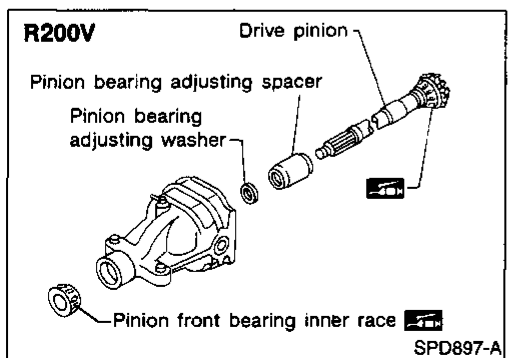

# ASSEMBLY

## Differential Carrier (Cont'd)

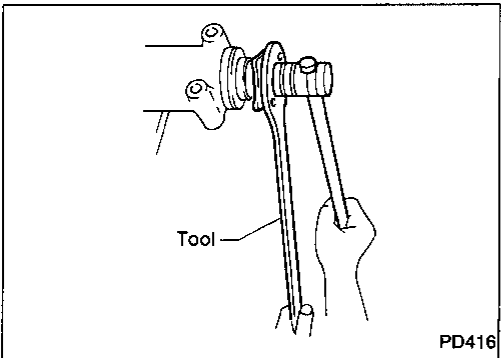
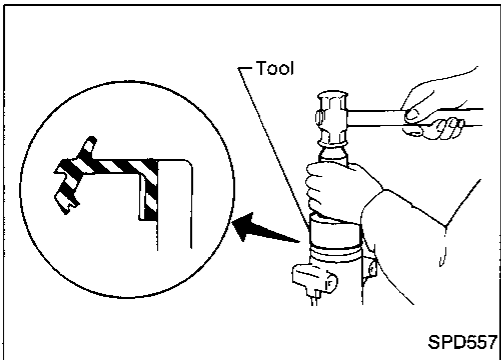
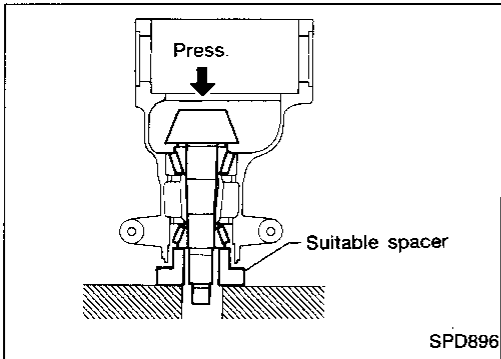
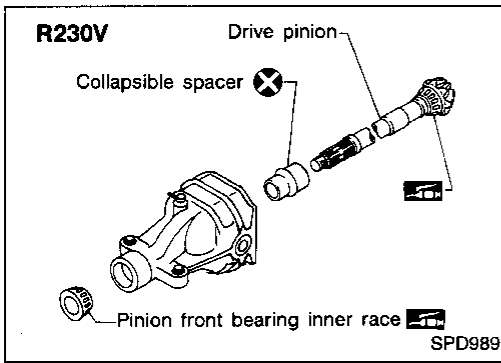

6. Apply multi-purpose grease to cavity at sealing lips of oil seal. Install front oil seal with Tool.

**Tool number:**

KV38100500 ( — ) — R200V —  
( — ) — R230V —

7. Install companion flange.

— R200V —

Tighten pinion nut to specified torque with Tool.

— R230V —

Tighten pinion nut to 127 N·m (13 kg·m, 94 ft·lb)

**Make sure that threaded portion of drive pinion and pinion nut are free from oil or grease.**

**Tool number:**

ST38060002 (J34311) — R200V —  
( — ) — R230V —

GI

MA

EM

LC

EF &  
EC

FE

CL

MT

AT

**PD**

FA

RA

BR

ST

RS

BT

HA

EL

IDX

## ASSEMBLY

### Differential Carrier (Cont'd)

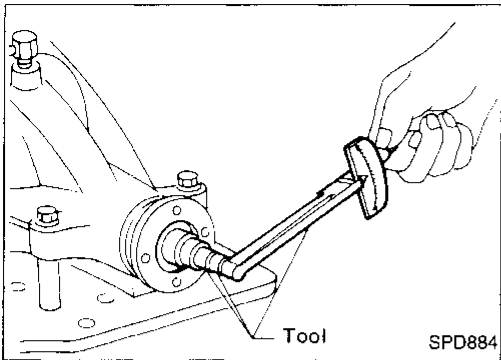

#### 8. —R200V —

Turn drive pinion in both directions several times, and measure pinion bearing preload.

##### Pinion bearing preload:

1.1 - 1.4 N·m  
(11 - 14 kg·cm, 9.5 - 12.2 in·lb)

When pinion bearing preload is outside specifications, replacement is required for pinion bearing adjusting washer and spacer. Replace with those of different thickness.

#### — R230V —

Tighten the pinion nut by very small degrees until the specified preload is achieved. When checking the preload, turn the drive pinion in both directions several times to set the bearing rollers.

##### Pinion bearing preload:

1.8 - 2.6 N·m  
(18 - 27 kg·cm, 16 - 23 in·lb)

#### CAUTION:

The preload is achieved by using the permanent set of collapsible spacer. So here, if an overpreload results from excessive turning of the pinion nut, the spacer should be replaced by a new one.

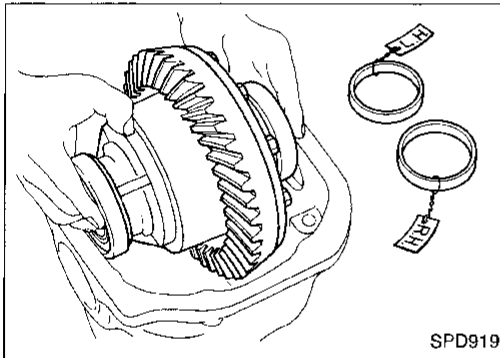

9. Install differential case assembly with side bearing outer races into gear carrier.

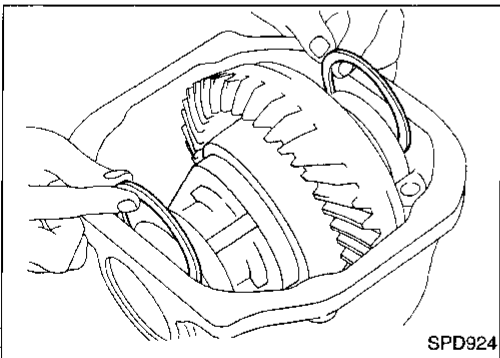

10. Insert left and right side bearing adjusting washers in place between side bearings and carrier.

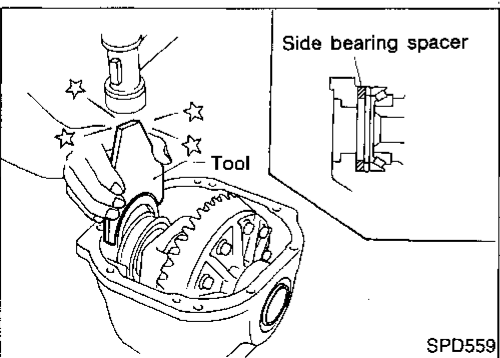

11. Drive in side bearing spacer with Tool.

##### Tool number:

KV38100600 (J25267) — R200V —  
( — ) — R230V —



## ASSEMBLY

### Differential Carrier (Cont'd)

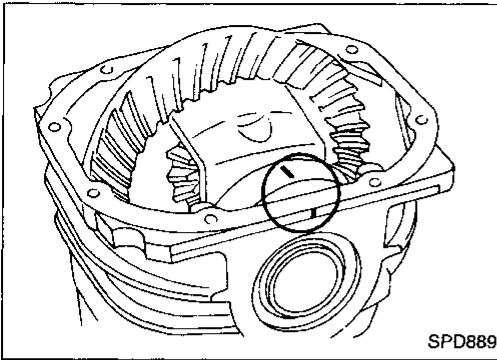

12. Align mark on bearing cap with that on gear carrier and install bearing cap on gear carrier.

GI

MA

EM

LC

EF &

EC

FE

CL

MT

AT

PD

FA

RA

BR

ST

RS

BT

HA

EL

IDX

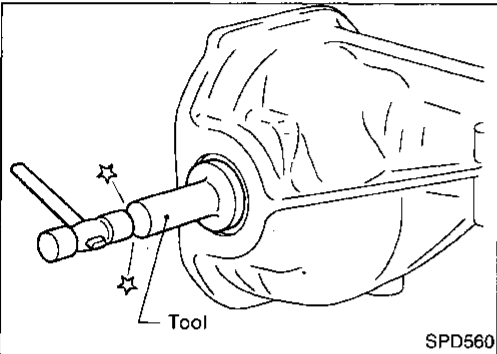

13. Apply multi-purpose grease to cavity at sealing lips of oil seal. Install side oil seal.

**Tool number:**

**KV38100200 (J26233) — R200V —**

**KV38102510 ( — ) — R230V —**

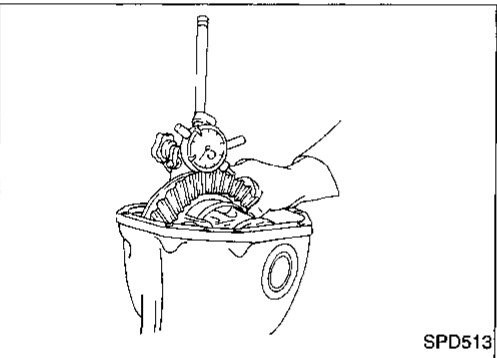

14. Measure ring gear to drive pinion backlash with a dial indicator.

**Ring gear to drive pinion backlash:**

**R200V 0.10 - 0.15 mm (0.0039 - 0.0059 in)**

**R230V 0.13 - 0.18 mm (0.0051 - 0.0071 in)**

- If backlash is too small, adjustment of shim thickness is required. Decrease thickness of left shim and increase thickness of right shim by the same amount.
- If backlash is too great, reverse the above procedure.

**Never change the total amount of shims as it will change the bearing preload.**

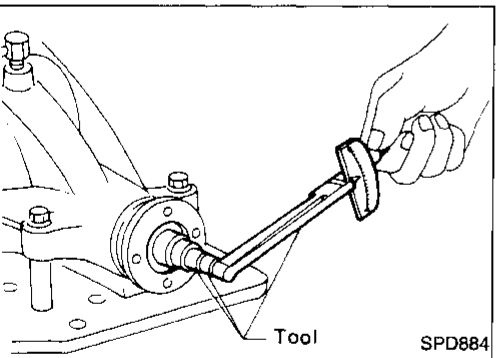

15. Check total preload with Tool.

**When checking preload, turn drive pinion in both directions several times to seat bearing rollers correctly.**

**Total preload:**

**R200V 1.4 - 3.1 N·m (14 - 32 kg·cm, 12 - 28 in·lb)**

**R230V 2.1 - 4.1 N·m (21 - 42 kg·cm, 18 - 36 in·lb)**

- If preload is too great, remove the same amount of shim from each side.
- If preload is too small, add the same amount of shim to each side.

**Never add or remove a different number of shims for each side. Difference in number of shims will change ring gear to drive pinion backlash.**

16. Recheck ring gear to drive pinion backlash. Increase or decrease in thickness of shims will cause change to ring gear to pinion backlash.

- Check whether the backlash varies excessively in different places. Foreign matter may be caught between the ring gear and the differential case causing the trouble.
- The backlash can vary greatly even when the ring gear runout is within a specified range. In that case, replace the hypoid gear set or differential case.

## ASSEMBLY

### Differential Carrier (Cont'd)

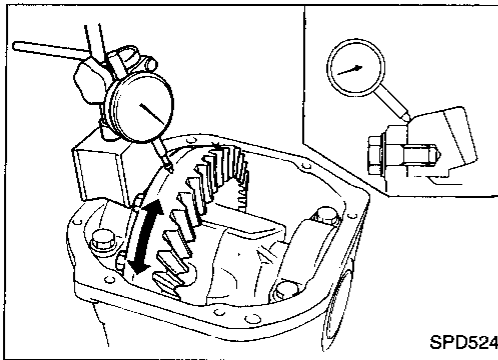

17. Check runout of ring gear with a dial indicator.

**Runout limit:**

**0.05 mm (0.0020 in)**

18. Check tooth contact.

Refer to ADJUSTMENT (PD-28).

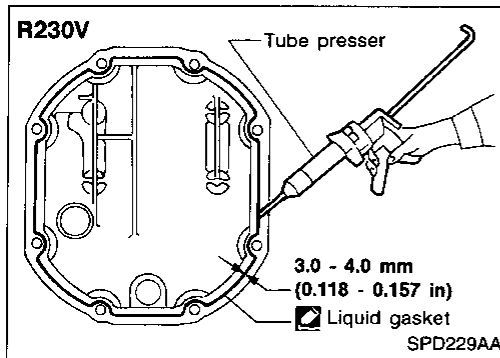

19. Install rear cover and gasket.

Use liquid gasket for R230V.

- a. Remove all traces of liquid gasket from mating surface of rear cover and gear carrier using a scraper.
- b. Apply a continuous bead of liquid gasket only to mating surface of rear cover.

- **Use Genuine Liquid Gasket or equivalent.**
- **Attaching should be done within 5 minutes after coating.**
- **Wait at least 1 hour before refilling gear oil.**
- **For the first 12 hours avoid abrupt acceleration or deceleration.**

# SERVICE DATA AND SPECIFICATIONS (SDS)

## Propeller Shaft

### GENERAL SPECIFICATIONS

Vehicle model	2 seater				2+2 seater	
Engine	VG30DETT		VG30DE			
Transmission	M/T	A/T	M/T	A/T	M/T	A/T
Propeller shaft model	3S80A-VL107		3S71A			
Number of joints	3					
Coupling method with transmission	Sleeve type					
Types of journal bearings	Shell type (non-disassembly type) x 2, CVJ* x 1		Shell type (non-disassembly type)			
Distance between yokes	mm (in)	80.0 (3.150)		71.0 (2.795)		
Shaft length (Spider to spider)	mm (in)					
1st		606 (23.86)	489 (19.25)	606 (23.86)	510 (20.08)	606 (23.86) 510 (20.08)
2nd		388 (15.28)		419 (16.50)		539 (21.22)
Shaft outer diameter	mm (in)					
1st		82.6 (3.252)		75 (2.95)		
2nd		75.2 (2.961)		75 (2.95)		

\*: Constant velocity joint

### INSPECTION AND ADJUSTMENT

Unit: mm (in)

Propeller shaft model	3S71A	3S80A-VL107
Journal axial play	0 (0)	
Propeller shaft runout limit	0.6 (0.024)	

## Final Drive

### GENERAL SPECIFICATIONS

Engine	VG30DE	VG30DETT
Final drive model	R200V	R230V
Ring gear pitch diameter	mm (in)	
205 (8.07)		230 (9.06)
Gear ratio	4.083	3.692
Number of teeth (Ring gear/Drive pinion)	49/12	48/13
Oil capacity (approx.) (US pt, Imp pt)	1.3 (2-3/4, 2-1/4)	1.8 (3-7/8, 3-1/8)

### INSPECTION AND ADJUSTMENT (R200V)

#### Ring gear runout

Ring gear runout limit	mm (in)	0.05 (0.0020)
------------------------	---------	---------------

#### Side gear adjustment

Side gear backlash (Clearance between side gear and differential case)	mm (in)	0.03 - 0.09 (0.0012 - 0.0035)
--	---------	----------------------------------

### Available side gear thrust washers

Thickness mm (in)	Part number
0.80 (0.0315)	38424-40F60
0.83 (0.0327)	38424-40F61
0.86 (0.0339)	38424-40F62
0.89 (0.0350)	38424-40F63
0.92 (0.0362)	38424-40F64
0.95 (0.0374)	38424-40F65
0.98 (0.0386)	38424-40F66
1.01 (0.0398)	38424-40F67
1.04 (0.0409)	38424-40F68
1.07 (0.0421)	38424-40F69
1.10 (0.0433)	38424-40F70
1.13 (0.0445)	38424-40F71
1.16 (0.0457)	38424-40F72
1.19 (0.0469)	38424-40F73
1.22 (0.0480)	38424-40F74
1.25 (0.0492)	38424-40F75
1.28 (0.0504)	38424-40F76
1.31 (0.0516)	38424-40F77
1.34 (0.0528)	38424-40F78
1.37 (0.0539)	38424-40F79
1.40 (0.0551)	38424-40F80
1.43 (0.0563)	38424-40F81
1.46 (0.0575)	38424-40F82
1.49 (0.0587)	38424-40F83

# SERVICE DATA AND SPECIFICATIONS (SDS)

## Final Drive (Cont'd)

### Side bearing adjustment

Side bearing preload measured at ring gear retaining bolt N (kg, lb)	34.3 - 39.2 (3.5 - 4.0, 7.7 - 8.8)
---	---------------------------------------

### Available side bearing adjusting washers

Thickness mm (in)	Part number
2.00 (0.0787)	38453-N3100
2.05 (0.0807)	38453-N3101
2.10 (0.0827)	38453-N3102
2.15 (0.0846)	38453-N3103
2.20 (0.0866)	38453-N3104
2.25 (0.0886)	38453-N3105
2.30 (0.0906)	38453-N3106
2.35 (0.0925)	38453-N3107
2.40 (0.0945)	38453-N3108
2.45 (0.0965)	38453-N3109
2.50 (0.0984)	38453-N3110
2.55 (0.1004)	38453-N3111
2.60 (0.1024)	38453-N3112
2.65 (0.1043)	38453-N3133

### Drive pinion height adjustment

#### Available pinion height adjusting washers

Thickness mm (in)	Part number
3.09 (0.1217)	38154-P6017
3.12 (0.1228)	38154-P6018
3.15 (0.1240)	38154-P6019
3.18 (0.1252)	38154-P6020
3.21 (0.1264)	38154-P6021
3.24 (0.1276)	38154-P6022
3.27 (0.1287)	38154-P6023
3.30 (0.1299)	38154-P6024
3.33 (0.1311)	38154-P6025
3.36 (0.1323)	38154-P6026
3.39 (0.1335)	38154-P6027
3.42 (0.1346)	38154-P6028
3.45 (0.1358)	38154-P6029
3.48 (0.1370)	38154-P6030
3.51 (0.1382)	38154-P6031
3.54 (0.1394)	38154-P6032
3.57 (0.1406)	38154-P6033
3.60 (0.1417)	38154-P6034
3.63 (0.1429)	38154-P6035
3.66 (0.1441)	38154-P6036

### Drive pinion preload adjustment

Drive pinion preload with front oil seal N-m (kg-cm, in-lb)	1.1 - 1.4 (11 - 14, 9.5 - 12.2)
--	---------------------------------

### Available drive pinion bearing preload adjusting washers

Thickness mm (in)	Part number
3.80 - 3.82 (0.1496 - 0.1504)	38125-61001
3.82 - 3.84 (0.1504 - 0.1512)	38126-61001
3.84 - 3.86 (0.1512 - 0.1520)	38127-61001
3.86 - 3.88 (0.1520 - 0.1528)	38128-61001
3.88 - 3.90 (0.1528 - 0.1535)	38129-61001
3.90 - 3.92 (0.1535 - 0.1543)	38130-61001
3.92 - 3.94 (0.1543 - 0.1551)	38131-61001
3.94 - 3.96 (0.1551 - 0.1559)	38132-61001
3.96 - 3.98 (0.1559 - 0.1567)	38133-61001
3.98 - 4.00 (0.1567 - 0.1575)	38134-61001
4.00 - 4.02 (0.1575 - 0.1583)	38135-61001
4.02 - 4.04 (0.1583 - 0.1591)	38136-61001
4.04 - 4.06 (0.1591 - 0.1598)	38137-61001
4.06 - 4.08 (0.1598 - 0.1606)	38138-61001
4.08 - 4.10 (0.1606 - 0.1614)	38139-61001

### Available drive pinion bearing preload adjusting spacers

Length mm (in)	Part number
45.60 (1.7953)	38165-10V05
45.90 (1.8071)	38165-10V06
46.20 (1.8189)	38165-10V07
46.50 (1.8307)	38165-10V00
46.80 (1.8425)	38165-10V01

### Total preload

Total preload N-m (kg-cm, in-lb)	1.4 - 3.1 (14 - 32, 12 - 28)
Ring gear backlash mm (in)	0.10 - 0.15 (0.0039 - 0.0059)

# SERVICE DATA AND SPECIFICATIONS (SDS)

## Final Drive (Cont'd)

### INSPECTION AND ADJUSTMENT (R230V)

#### Ring gear runout

Ring gear runout limit	mm (in)	0.05 (0.0020)
------------------------	---------	---------------

#### Side gear adjustment

Side gear backlash (Clearance between side gear and differential case)	mm (in)	0.03 - 0.09 (0.0012 - 0.0035)
--	---------	----------------------------------

#### Available side gear thrust washers

Thickness mm (in)	Part number
0.80 (0.0315)	38424-40F00
0.85 (0.0335)	38424-40F08
0.90 (0.0354)	38424-40F01
0.95 (0.0374)	38424-40F09
1.00 (0.0394)	38424-40F02
1.05 (0.0413)	38424-40F10
1.10 (0.0433)	38424-40F03
1.15 (0.0453)	38424-40F11
1.20 (0.0472)	38424-40F04
1.25 (0.0492)	38424-40F12
1.30 (0.0512)	38424-40F05
1.35 (0.0531)	38424-40F13
1.40 (0.0551)	38424-40F06
1.45 (0.0571)	38424-40F14
1.50 (0.0591)	38424-40F07

#### Side bearing adjustment

Side bearing preload mea- sured at ring gear retaining bolt	N (kg, lb)	34.3 - 39.2 (3.5 - 4.0, 7.7 - 8.8)
---	------------	---------------------------------------

#### Available side bearing adjusting washers

Thickness mm (in)	Part number
2.00 (0.0787)	38453-40P00
2.05 (0.0807)	38453-40P01
2.10 (0.0827)	38453-40P02
2.15 (0.0846)	38453-40P03
2.20 (0.0866)	38453-40P04
2.25 (0.0886)	38453-40P05
2.30 (0.0906)	38453-40P06
2.35 (0.0925)	38453-40P07
2.40 (0.0945)	38453-40P08
2.45 (0.0965)	38453-40P09
2.50 (0.0984)	38453-40P10
2.55 (0.1004)	38453-40P11
2.60 (0.1024)	38453-40P12

### Drive pinion height adjustment

#### Available pinion height adjusting washers

Thickness mm (in)	Part number
2.59 (0.1020)	38154-40P00
2.61 (0.1028)	38154-40P01
2.63 (0.1035)	38154-40P02
2.65 (0.1043)	38154-40P03
2.67 (0.1051)	38154-40P04
2.69 (0.1059)	38154-40P05
2.71 (0.1067)	38154-40P06
2.73 (0.1075)	38154-40P07
2.75 (0.1083)	38154-40P08
2.77 (0.1091)	38154-40P09
2.79 (0.1098)	38154-40P10
2.81 (0.1106)	38154-40P11
2.83 (0.1114)	38154-40P12
2.85 (0.1122)	38154-40P13
2.87 (0.1130)	38154-40P14
2.89 (0.1138)	38154-40P15
2.91 (0.1146)	38154-40P16
2.93 (0.1154)	38154-40P17
2.95 (0.1161)	38154-40P18
2.97 (0.1169)	38154-40P19

#### Drive pinion preload adjustment

Drive pinion preload with front oil seal	N·m (kg-cm, in-lb)	1.8 - 2.6 (18 - 27, 16 - 23)
---	--------------------	---------------------------------

#### Total preload adjustments

Total preload	N·m (kg-cm, in-lb)	2.1 - 4.1 (21 - 42, 18 - 36)
Ring gear backlash	mm (in)	0.13 - 0.18 (0.0051 - 0.0071)

GI

MA

EM

LC

EF &amp;

EC

FE

CL

MT

AT

PD

FA

RA

BR

ST

RS

BT

HA

EL

IDX