

SECTION **MT**

GI

MA

EM

LC

EC

FE

CL

MT

AT

PD

FA

RA

BR

ST

RS

BT

HA

EL

IDX

CONTENTS

PREPARATION	2	DISASSEMBLY	11
Special Service Tools	2	Case Components	11
Commercial Service Tool.....	3	Shift Control Components	12
ON-VEHICLE SERVICE	4	Gear Components	13
Replacing Rear Oil Seal	4	INSPECTION	17
Position Switch Check.....	4	Shift Control Components	17
REMOVAL AND INSTALLATION	5	Gear Components	17
Removal.....	5	ASSEMBLY	19
Installation.....	5	Gear Components	19
MAJOR OVERHAUL	6	Shift Control Components	27
Case Components.....	6	Case Components.....	27
Gear Components	7	SERVICE DATA AND SPECIFICATIONS (SDS)	30
Shift Control Components	9	General Specifications.....	30
		Inspection and Adjustment	30

PREPARATION

Special Service Tools

The actual shapes of Kent-Moore tools may differ from those of special service tools illustrated here.

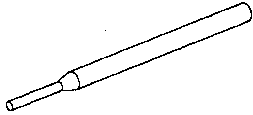
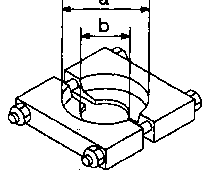
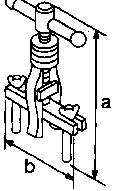
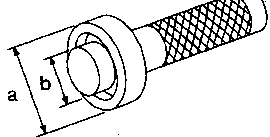
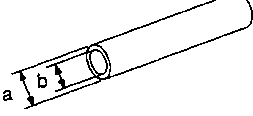
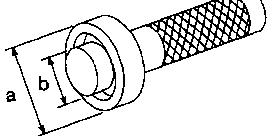
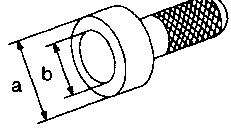
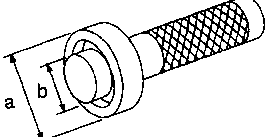
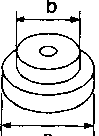
Tool number (Kent-Moore No.) Tool name	Description	
ST23540000 (J25689-A) Pin punch	 NT070	Removing and installing retaining pin
ST30031000 (J22912-01) Puller	 NT411	Removing 1st & 2nd synchronizer assembly Removing counter gear rear thrust bearing Removing main drive bearing Measuring 2nd & 3rd inner baulk ring a: 90 mm (3.54 in) dia. b: 50 mm (1.97 in) dia.
ST33290001 (J34286) Puller	 NT414	Removing rear oil seal a: 250 mm (9.84 in) b: 160 mm (6.30 in)
ST33230000 (—) Drift	 NT084	Removing mainshaft and counter gear a: 51 mm (2.01 in) dia. b: 28.5 mm (1.122 in) dia.
ST22350000 (J25678-01) Drift	 NT065	Removing counter gear front bearing (Use with KV38100300) a: 34 mm (1.34 in) dia. b: 28 mm (1.10 in) dia.
KV38100300 (J25523) Drift	 NT084	Removing counter gear front bearing (Use with ST22350000) Installing counter gear rear bearing a: 54 mm (2.13 in) dia. b: 32 mm (1.26 in) dia.
ST30720000 ① (J34286) ② (J34331) Drift	 NT115	① Removing mainshaft front bearing ② Installing mainshaft front bearing a: 77 mm (3.03 in) dia. b: 55.5 mm (2.185 in) dia.
ST33210001 ① (J25523) ② (J25803-01) Drift	 NT084	① Installing counter gear front bearing ② Installing front cover oil seal a: 44 mm (1.73 in) dia. b: 24.5 mm (0.965 in) dia.
ST30613000 (J25742-3) Drift	 NT073	Installing main drive gear bearing a: 72 mm (2.83 in) dia. b: 48 mm (1.89 in) dia.

PREPARATION

Special Service Tools (Cont'd)

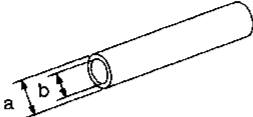
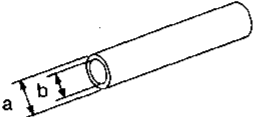
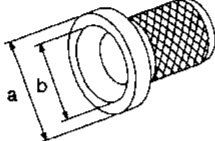
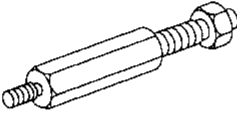
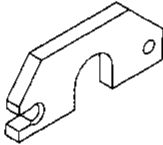
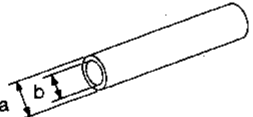
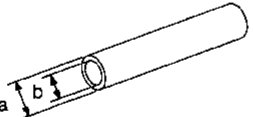
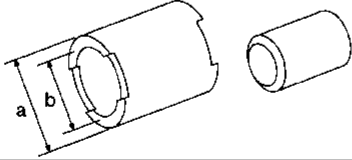
Tool number (Kent-Moore No.) Tool name	Description	
ST37750000 ① (J34286) ② (J34332) ③ (J34334) ④ (J25679-01) Drift		<ul style="list-style-type: none"> ① Removing counter gear rear bearing ② Installing OD gear bushing ② Installing reverse cone ③ Installing reverse counter gear ④ Installing counter gear rear end bearing <p>a: 40 mm (1.57 in) dia. b: 31 mm (1.22 in) dia.</p>
ST22452000 (J34337) Drift		Installing reverse hub Installing mainshaft rear bearing <p>a: 45 mm (1.77 in) dia. b: 36 mm (1.42 in) dia.</p>
ST33400001 (J26082) Drift		Installing rear oil seal <p>a: 60 mm (2.36 in) dia. b: 47 mm (1.85 in) dia.</p>
(J26349-3) Puller leg		Installing mainshaft and counter gear (Use with J34328)
(J34328) Puller		Installing mainshaft and counter gear (Use with J26349-3)
(J26092) Drift		Installing sub-gear snap ring <p>a: 44.5 mm (1.752 in) dia. b: 38.5 mm (1.516 in) dia.</p>
(J34342) Drift		Installing OD main gear Installing reverse gear bushing <p>a: 44.5 mm (1.752 in) dia. b: 40.5 mm (1.594 in) dia.</p>
ST36730000 (—) Drift		Installing sub-gear on reverse idler gear <p>a: 50 mm (1.97 in) dia. b: 39 mm (1.54 in) dia.</p>

Commercial Service Tool

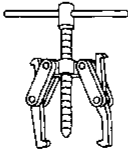
Tool name	Description	
Puller		Removing counter gear rear end bearing Removing mainshaft rear bearing Removing reverse synchronizer hub Removing reverse counter gear

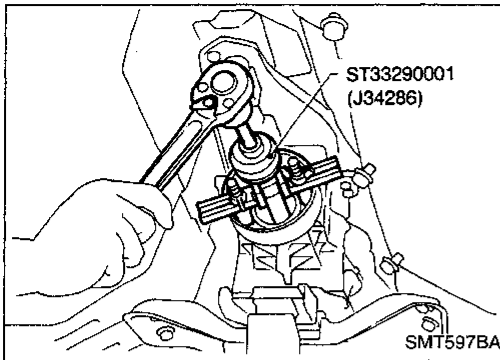

Replacing Rear Oil Seal

REMOVAL

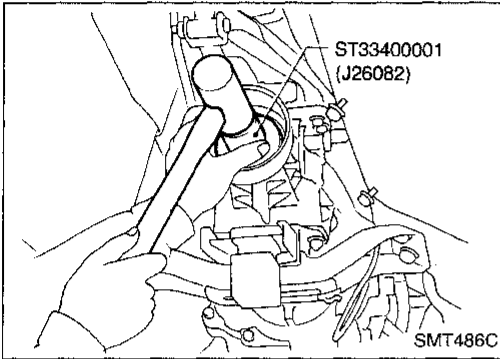

INSTALLATION

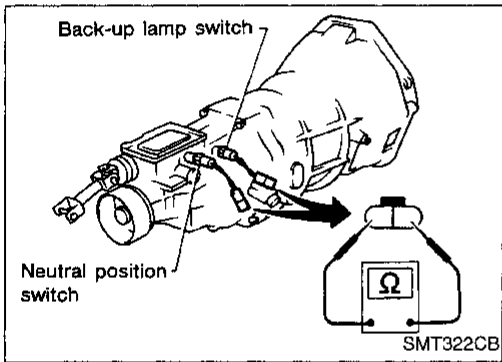

Position Switch Check

- Check continuity.

Switch	Gear position	Continuity
Back-up lamp switch	Reverse	Yes
	Except reverse	No
Neutral position switch	Neutral	Yes
	Except neutral	No

REMOVAL AND INSTALLATION

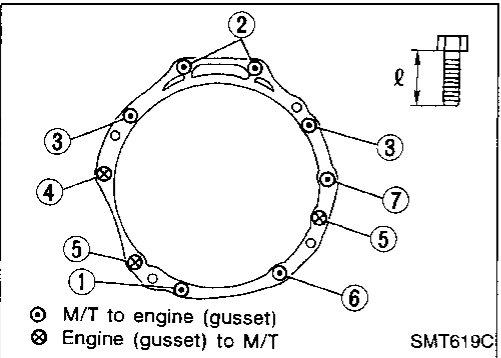
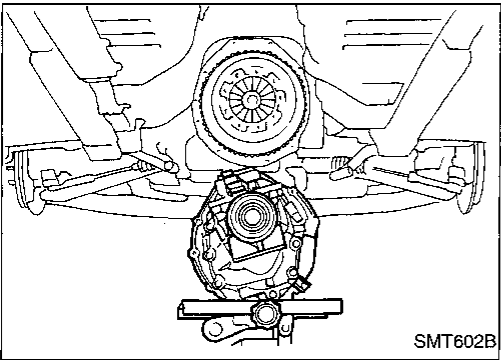
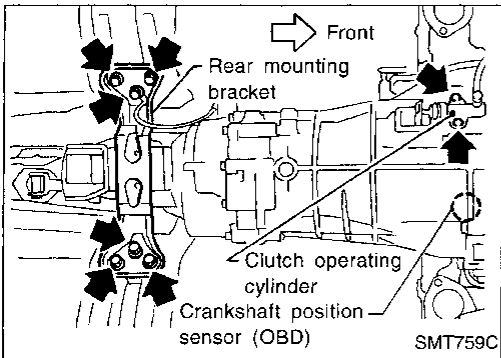
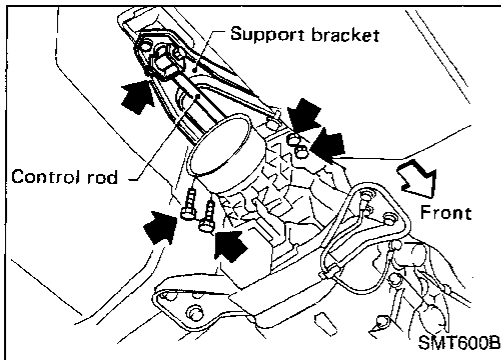

Removal

CAUTION:

When removing the transmission assembly from engine, first remove the crankshaft position sensor (OBD) from the assembly. Be careful not to damage sensor edge and ring gear teeth.

- Remove exhaust tube. Refer to FE section ("EXHAUST SYSTEM").
- Remove support bracket from M/T assembly.
- Remove control rod from control lever.
- Remove crankshaft position sensor (OBD) from transmission.
- Remove propeller shaft. Refer to PD section ("Removal", "PROPELLER SHAFT").
- **Insert plug into rear oil seal after removing propeller shaft.**
- **Be careful not to damage spline, sleeve yoke and rear oil seal when removing propeller shaft.**
- Disconnect back-up lamp switch, neutral position switch and vehicle speed sensor harness connectors.
- Remove clutch operating cylinder from transmission.
- Support manual transmission with a jack.
- Remove rear mounting bracket.
- Lower manual transmission as much as possible.
- Remove transmission fixing bolts.
- Remove transmission from engine.
- Support manual transmission while removing it.

Installation

- Tighten all transmission bolts.

Bolt No.	Tightening torque N·m (kg·m, ft·lb)	ℓ mm (in)
①	39 - 49 (4.0 - 5.0, 29 - 36)	100 (3.94)
②	39 - 49 (4.0 - 5.0, 29 - 36)	55 (2.17)
③	39 - 49 (4.0 - 5.0, 29 - 36)	60 (2.36)
④	29 - 39 (3.0 - 4.0, 22 - 29)	55 (2.17)
⑤	39 - 49 (4.0 - 5.0, 29 - 36)	25 (0.98)
⑥	29 - 39 (3.0 - 4.0, 22 - 29)	60 (2.36)
⑦	39 - 49 (4.0 - 5.0, 29 - 36)	65 (2.56)

Gear Components

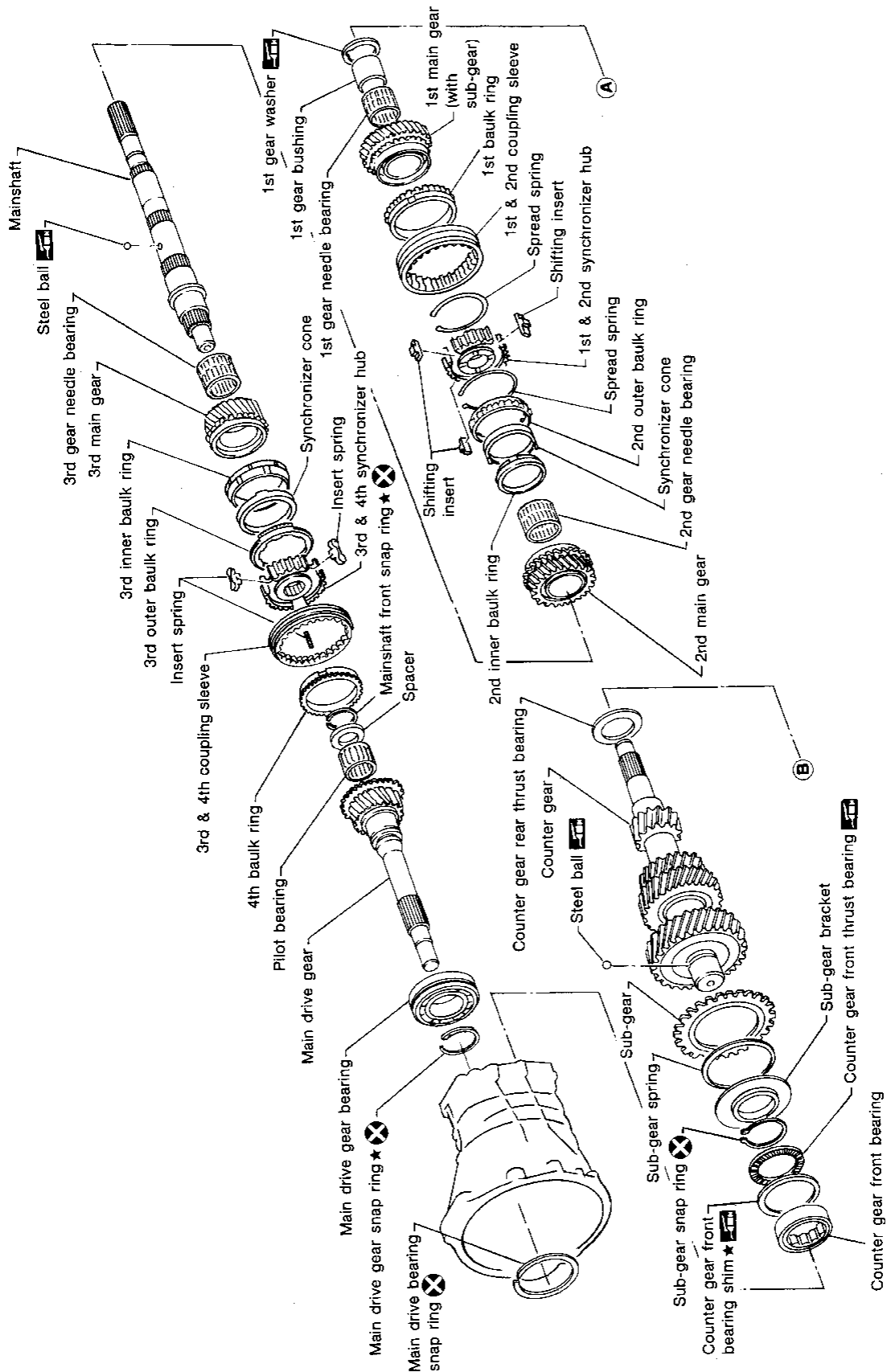

SEC. 322

GI
MA
EM
LC
EC
FE
CL
MT
AT
PD
FA
RA
BR
ST
RS
BT
HA
EL
IDX

MAJOR OVERHAUL

Gear Components (Cont'd)

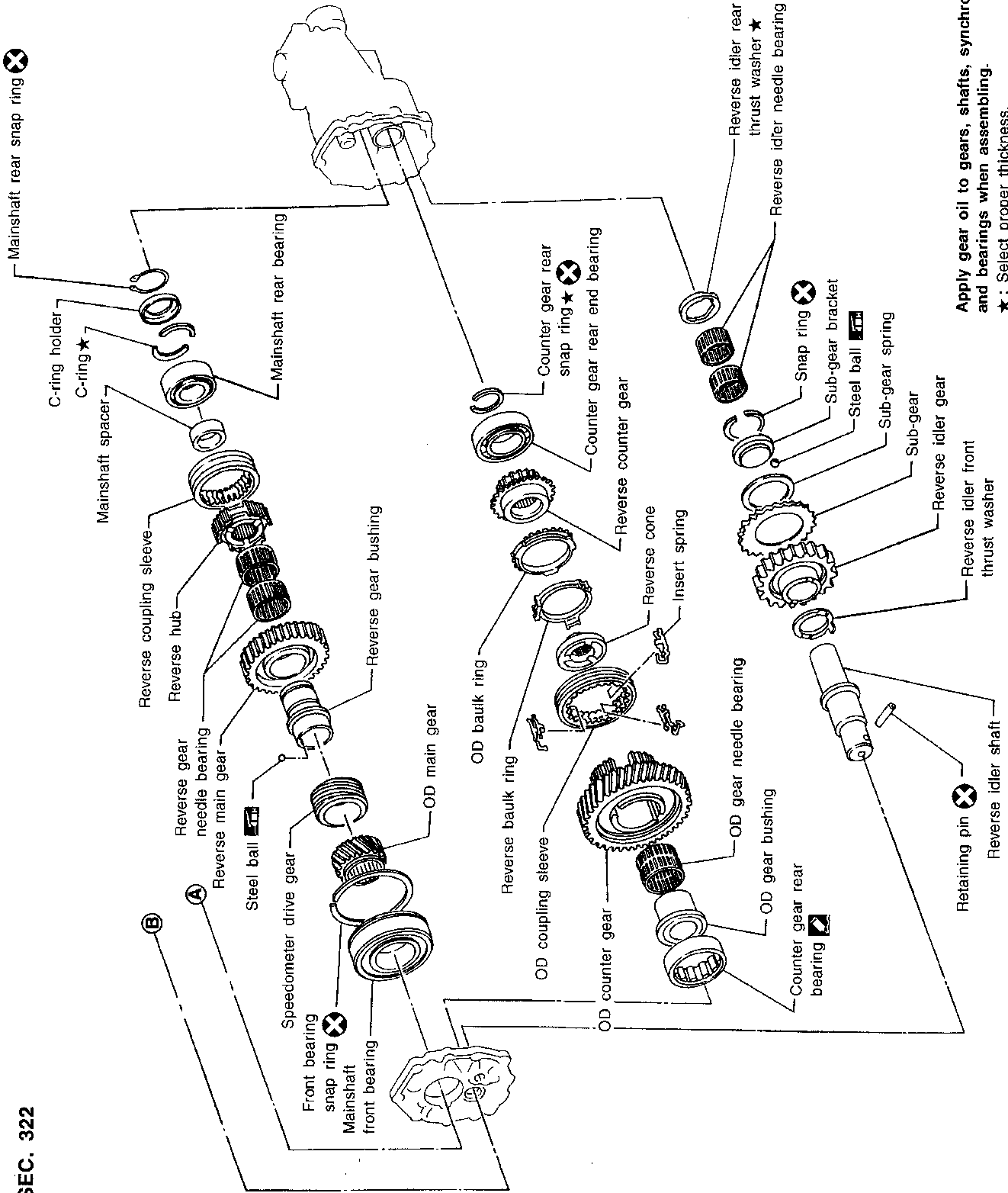

Apply gear oil to gears, shafts, synchronizers and bearings when assembling.
 ★ : Select proper thickness.

SEC. 322

MAJOR OVERHAUL

Shift Control Components

SEC. 328

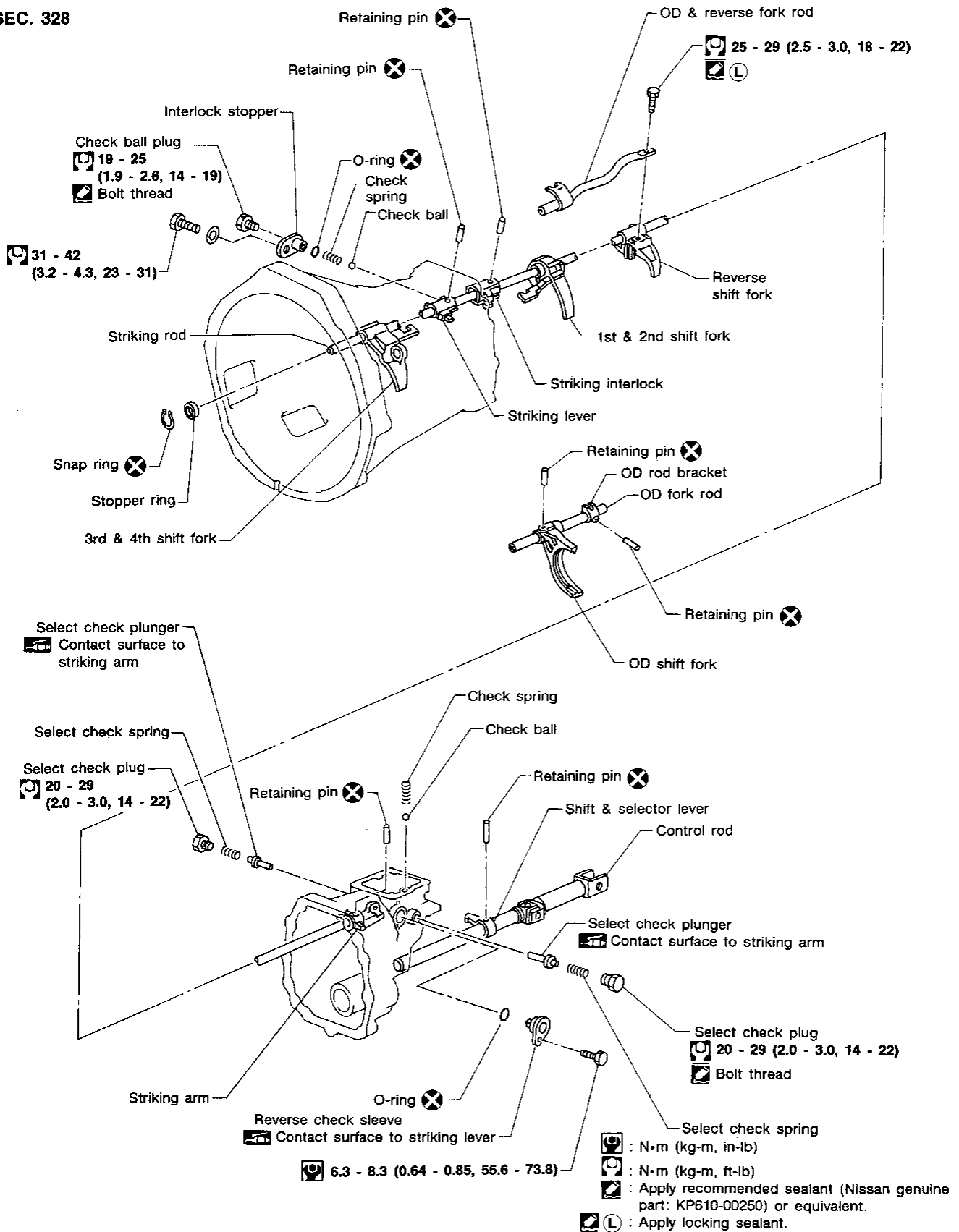

GI
MA
EM
LC
EC
FE
CL
MT
AT
PD
FA
RA
BR
ST
RS
BT
HA
EL
IDX

MAJOR OVERHAUL

Shift Control Components (Cont'd)

SEC. 328

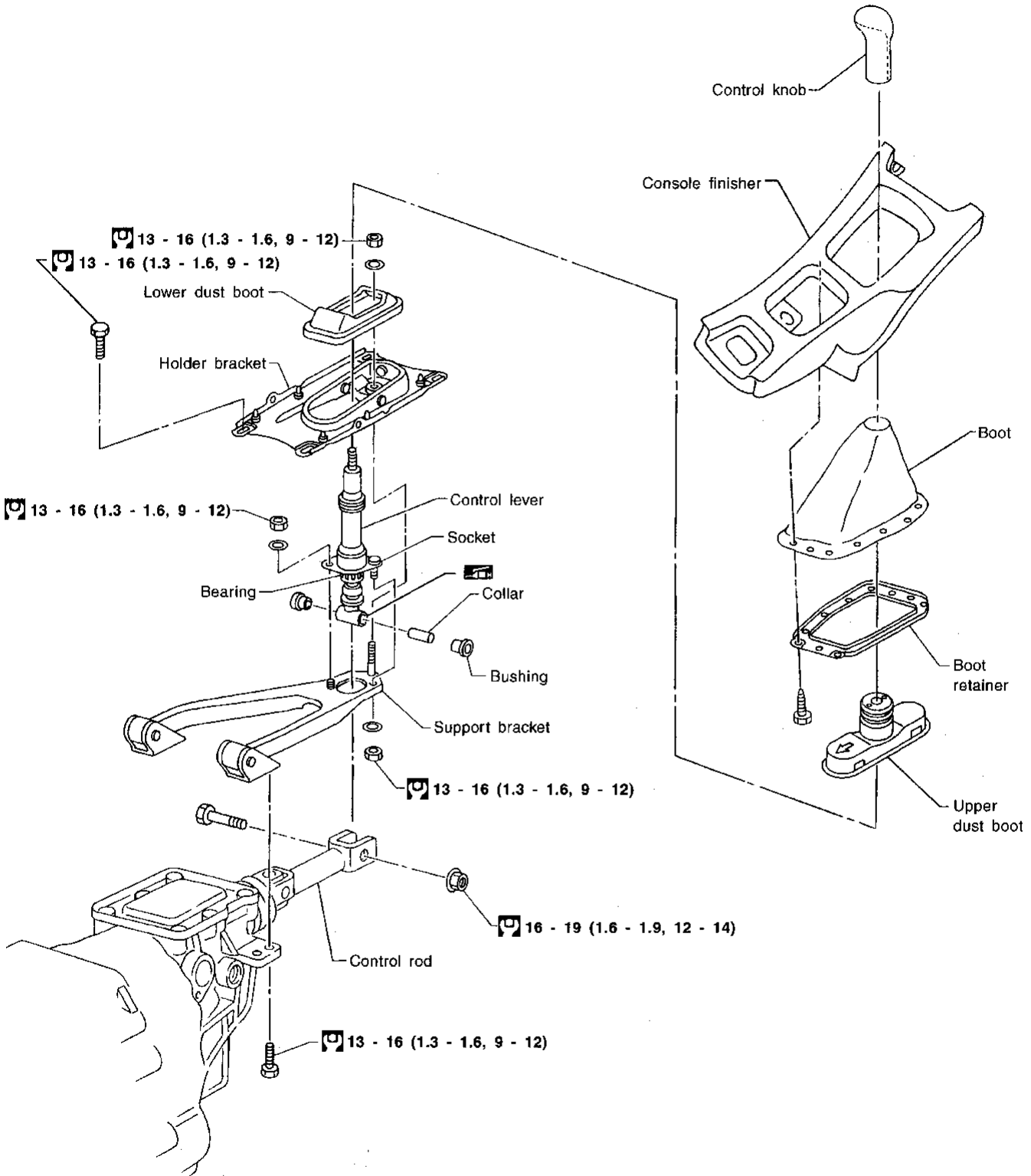

: N•m (kg-m, ft-lb)

DISASSEMBLY

Case Components

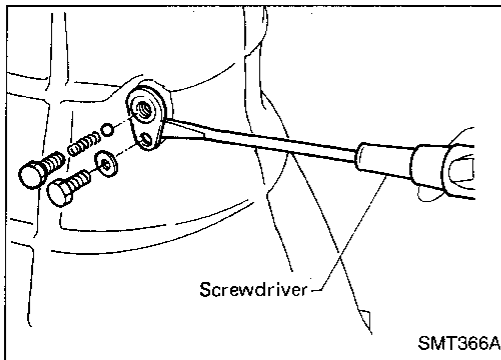

1. Remove check ball plug, check spring and check ball. Then remove interlock stopper.
 - If interlock assembly is removed as a unit, the check ball can fall into transmission case.

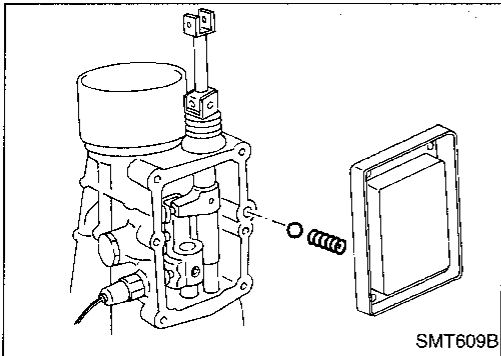

2. Remove control housing upper cover, check spring and check ball.

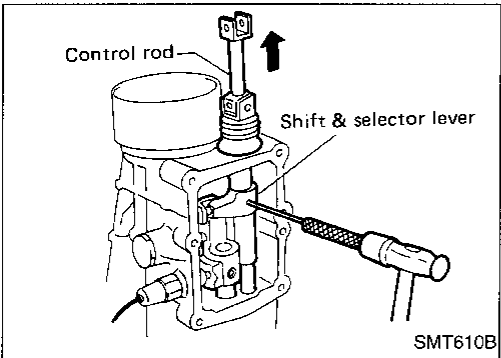

3. Drive out retaining pin from shift & selector lever.
4. Remove control rod from M/T assembly.
 - Be careful not to damage control rod oil seal and dust cover.

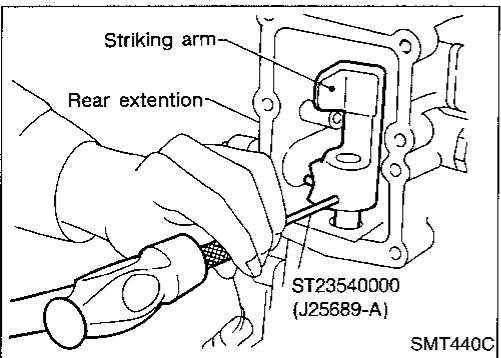

5. Drive out retaining pin from striking arm.
6. Remove rear extension together with striking arm by tapping lightly.

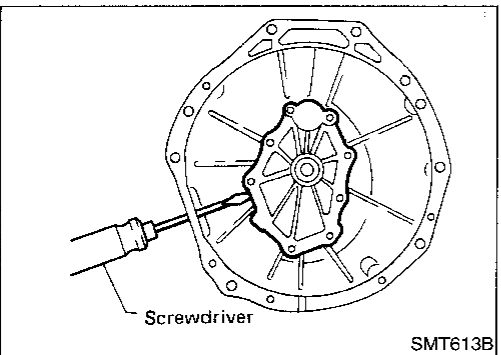

7. Remove front cover and gasket.

GI

MA

EM

LC

EC

FE

CL

MT

AT

PD

FA

RA

BR

ST

RS

BT

HA

EL

IDX

DISASSEMBLY

Case Components (Cont'd)

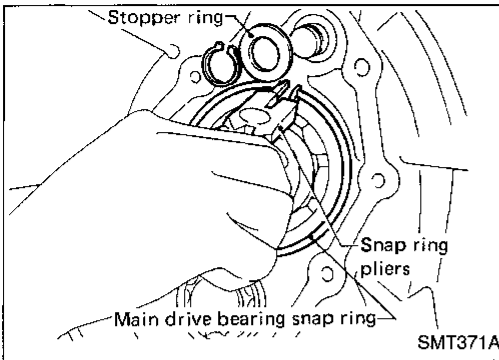

8. Remove stopper ring and main drive bearing snap ring.

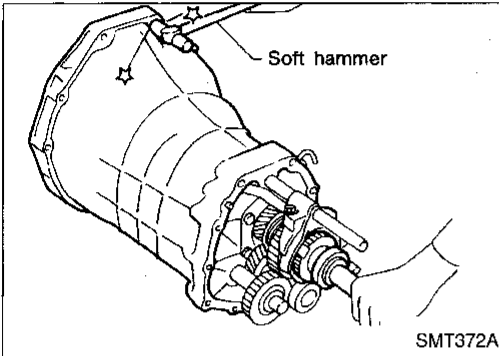

9. Remove transmission case by tapping lightly.

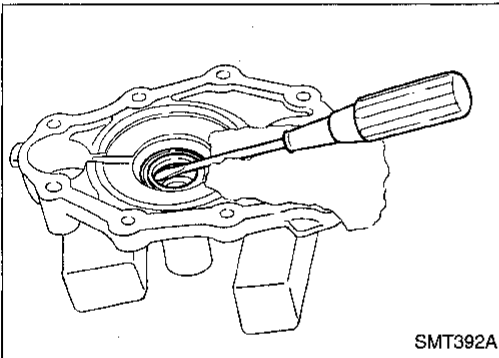

10. Remove front cover oil seal.

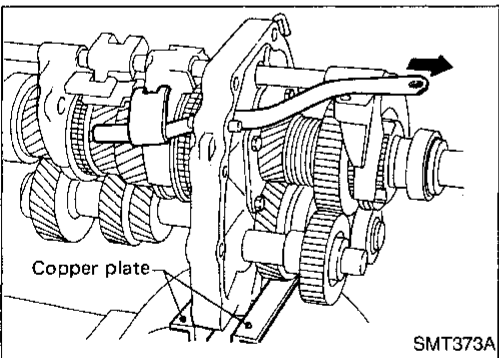

Shift Control Components

1. Mount adapter plate on vise.
2. Remove OD & reverse fork rod.

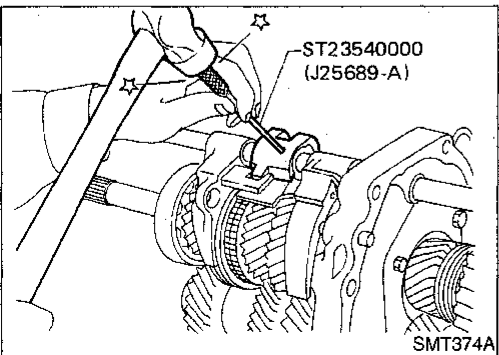

3. Drive out retaining pin from striking lever.
4. While pulling out striking rod, remove striking lever and striking interlock. Then remove 1st & 2nd, 3rd & 4th and reverse shift forks.

DISASSEMBLY

Shift Control Components (Cont'd)

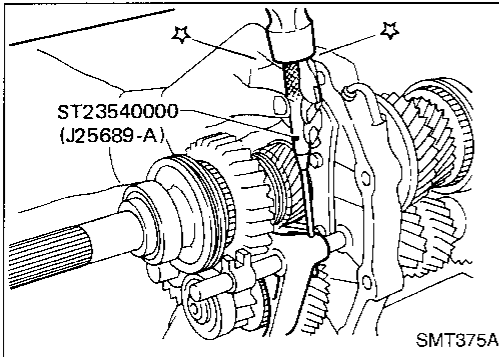

5. Drive out retaining pin from OD shift fork.
6. Pull out OD fork rod and then remove OD shift fork.

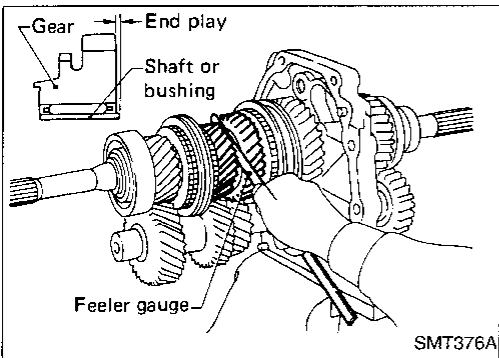

Gear Components

1. Before removing gears and shafts, measure each gear end play.

Gear end play:

Refer to SDS, MT-30.

- If not within specification, disassemble and check contact surface of gear to hub, washer, bushing, needle bearing and shaft.

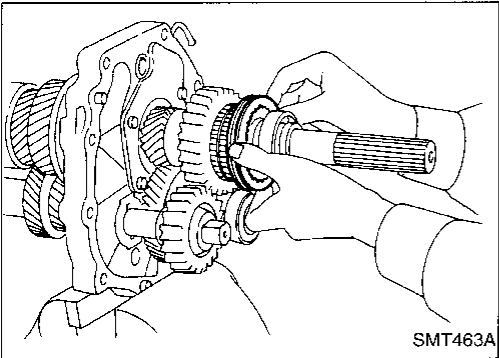

2. Remove rear side components on mainshaft and counter gear.
 - a. Remove snap ring, speedometer drive gear and steel ball.
 - b. Remove reverse coupling sleeve.

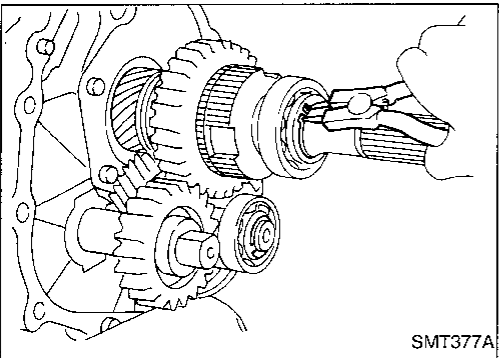

- c. Remove mainshaft rear snap ring and counter gear rear snap ring.
- d. Remove C-ring holder and mainshaft C-rings from mainshaft. Use punch and hammer to remove C-rings.

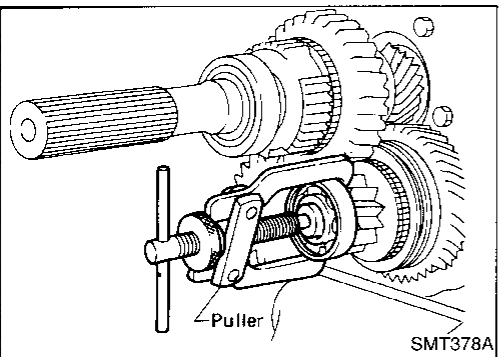

- e. Pull out counter gear rear end bearing.
- f. Remove reverse idler gear and reverse idler thrust washers.

GI

MA

EM

LC

EC

FE

CL

MT

AT

PD

FA

RA

BR

ST

RS

BT

HA

EL

IDX

DISASSEMBLY

Gear Components (Cont'd)

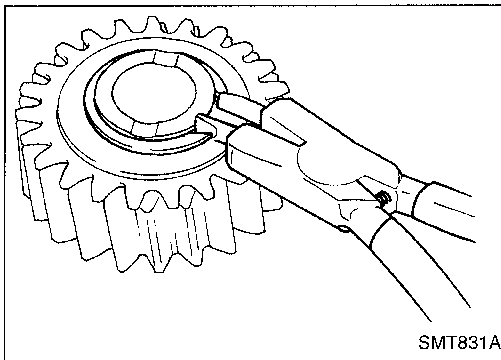

g. Remove sub-gear from reverse idler gear.

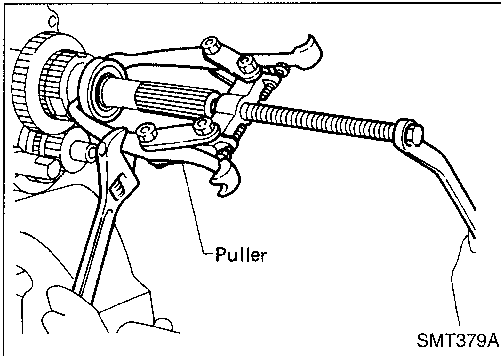

h. Pull out mainshaft rear bearing.

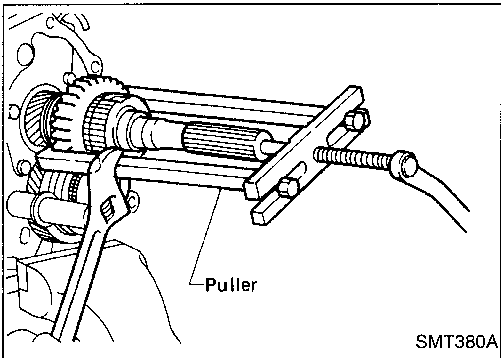

i. Pull out reverse main gear together with mainshaft spacer and reverse synchronizer hub. Then remove reverse gear needle bearings.

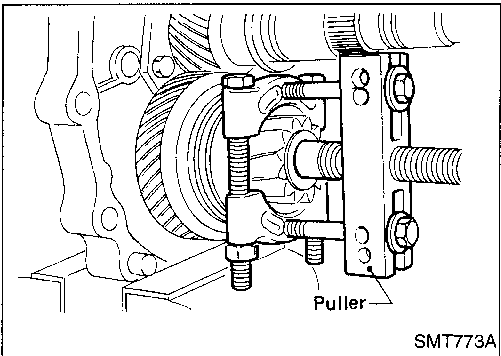

j. Pull out reverse counter gear.
k. Remove OD coupling sleeve together with OD baulk ring, reverse baulk ring and spring inserts.

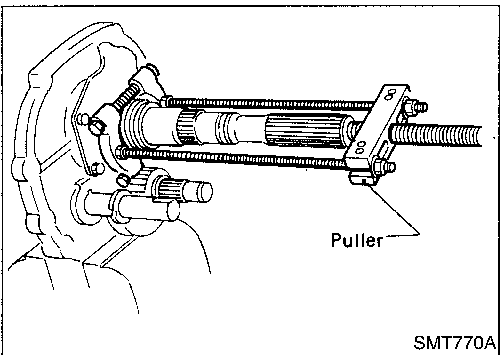

l. Pull out reverse gear bushing.

DISASSEMBLY

Gear Components (Cont'd)

m. Pull out OD counter gear together with reverse cone.

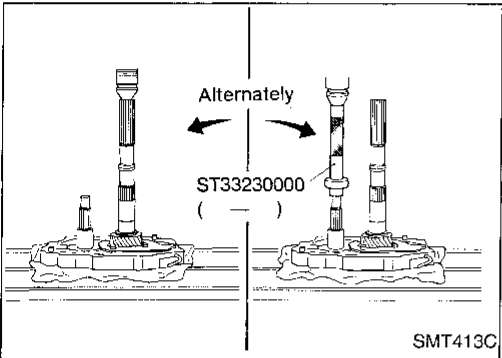
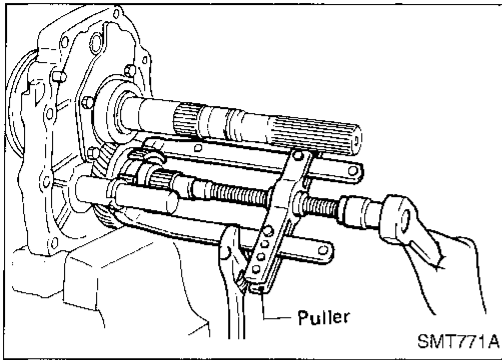

3. Press out mainshaft and counter gear. When pressing, ensure the following:

- Alternately press mainshaft and counter gear.
- Be careful not to allow the front surface of one to contact the rear surface of the other.

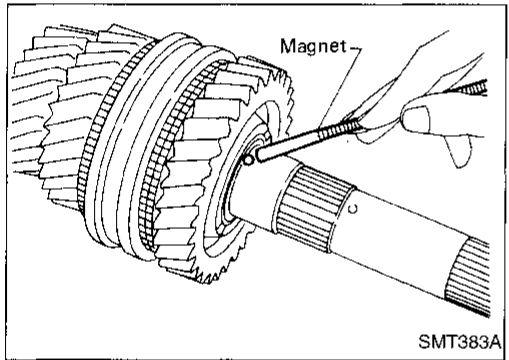

4. Remove front side components on mainshaft.

- a. Remove 1st gear washer and steel ball.
- b. Remove 1st main gear and 1st gear needle bearing.

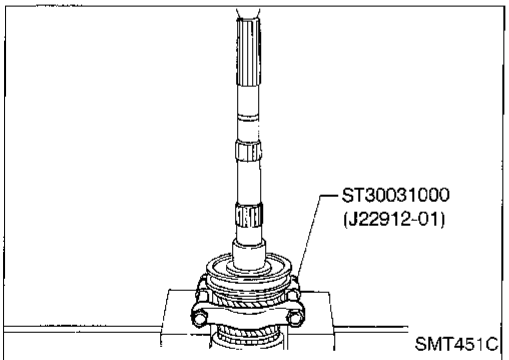

- c. Press out 2nd main gear together with 1st gear bushing and 1st & 2nd synchronizer assembly.
- d. Remove mainshaft front snap ring.

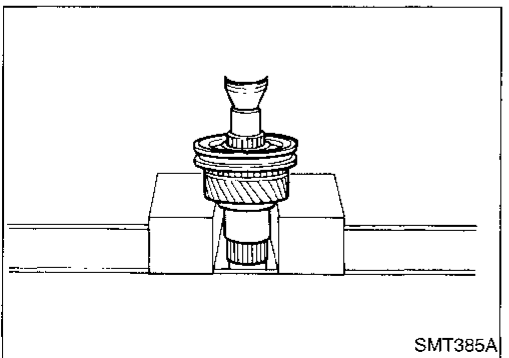

- e. Press out 3rd main gear together with 3rd & 4th synchronizer assembly and 3rd gear needle bearing.

GI

MA

EM

LC

EC

FE

CL

MT

AT

PD

FA

RA

BR

ST

RS

BT

HA

EL

IDX

DISASSEMBLY

Gear Components (Cont'd)

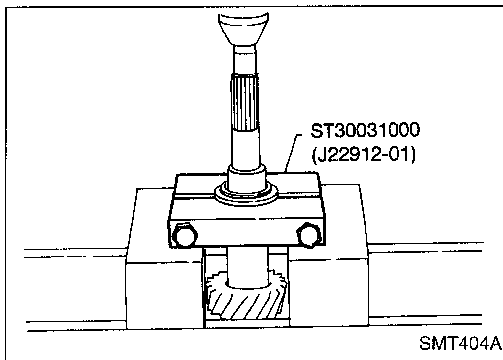

5. Remove front side components on counter gear.
 - a. Remove counter gear rear thrust bearing.

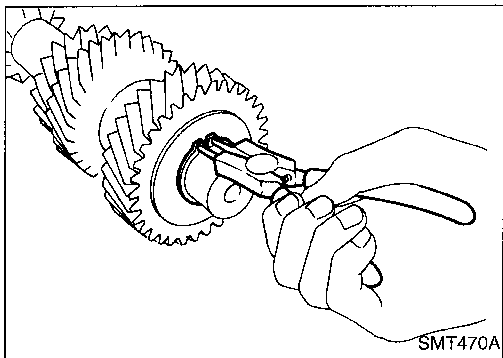

- b. Remove sub-gear components.

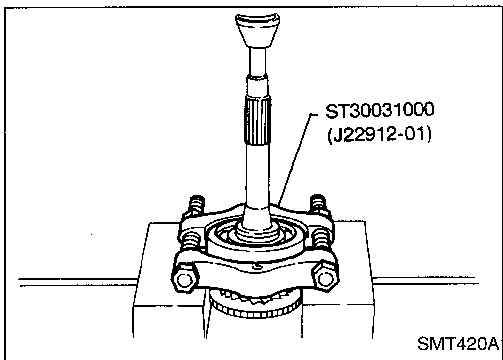

6. Remove main drive gear bearing.
 - a. Remove main drive gear snap ring and spacer.
 - b. Press out main drive gear bearing.

7. Remove bearings from case components.

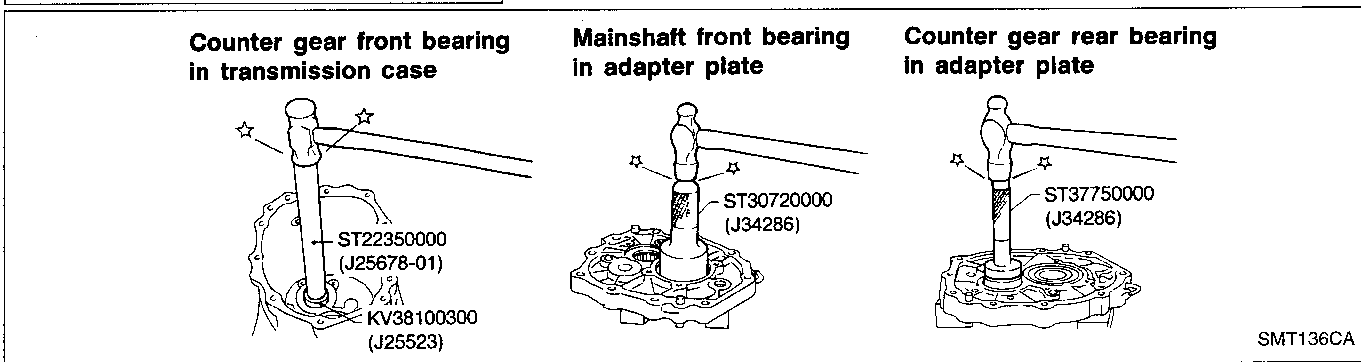

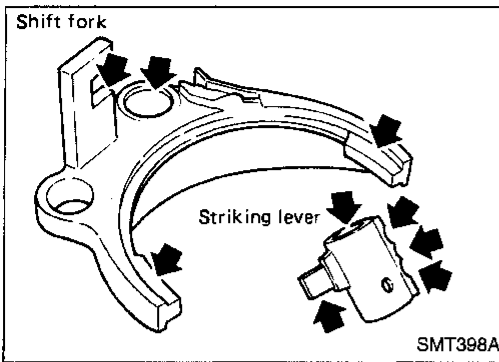

Shift Control Components

- Check contact surface and sliding surface for wear, scratches, projections or other damage.

GI

MA

EM

LC

EC

FE

CL

MT

AT

PD

FA

RA

BR

ST

RS

BT

HA

EL

IDX

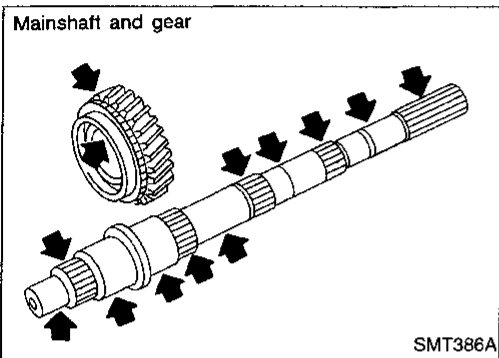

Gear Components

GEARS AND SHAFTS

- Check shafts for cracks, wear or bending.
- Check gears for excessive wear, chips or cracks.

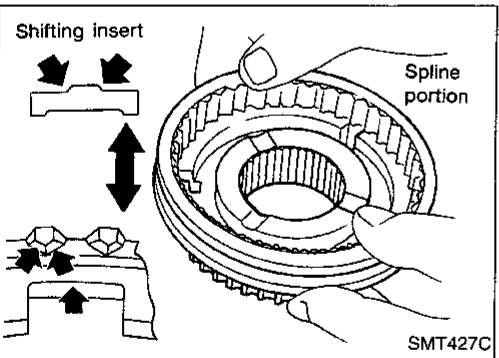
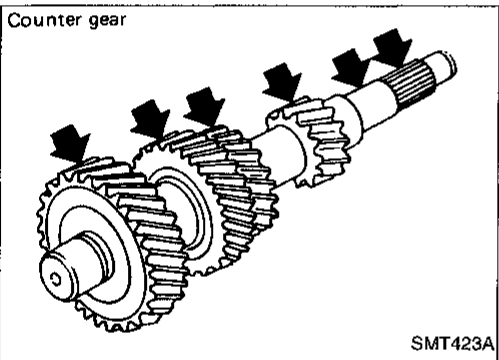

SYNCHRONIZERS

- Check spline portion of coupling sleeves, hubs, and gears for wear or cracks.
- Check baulk rings for cracks or deformation.
- Check shifting inserts for wear or deformation.
- Check insert springs for deformation.

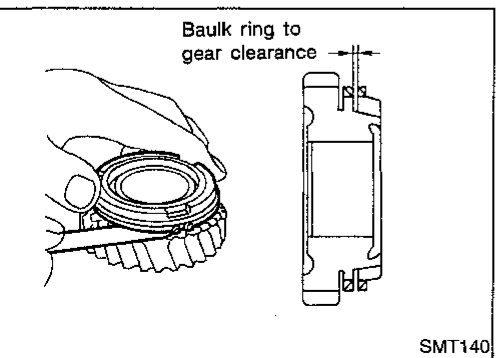

- Measure clearance between baulk ring and gear.
Clearance between 1st, main drive and OD baulk rings and gear:
Refer to SDS, MT-30.
- If the clearance is smaller than the wear limit, replace baulk ring.

INSPECTION

Gear Components (Cont'd)

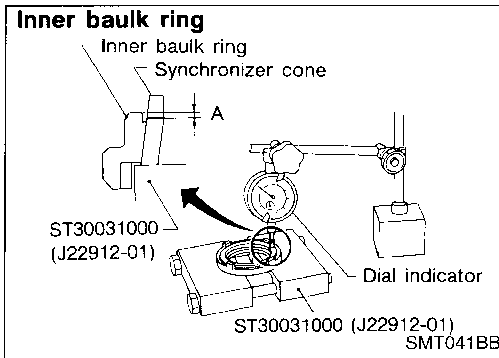

- Measure wear of 2nd and 3rd baulk rings.
 - a. Place inner baulk ring in position on synchronizer cone.
 - b. Hold baulk ring evenly against synchronizer cone and measure distance "A".
 - c. Place outer baulk ring in position on synchronizer cone.
 - d. Hold baulk ring evenly against synchronizer cone and measure distance "B".

Standard:

Inner-A 0.6 - 1.1 mm (0.024 - 0.043 in)

Outer-B 0.7 - 0.9 mm (0.028 - 0.035 in)

Wear limit:

0.2 mm (0.008 in)

- e. If distance "A" or "B" is smaller than the wear limit, replace baulk ring.

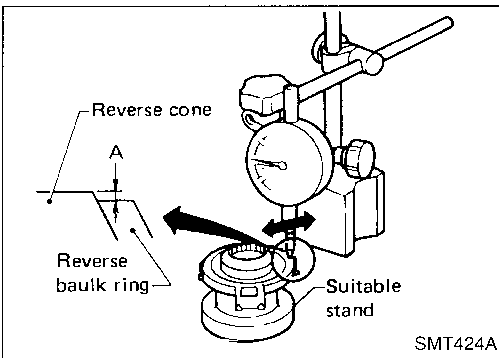
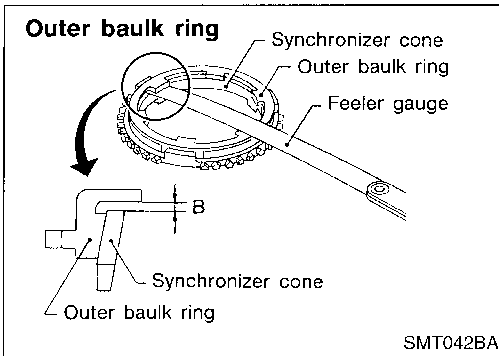

- Measure wear of reverse baulk ring.
 - a. Place baulk ring in position on reverse cone.
 - b. Hold baulk ring evenly against reverse cone and measure dimension "A" with dial indicator.

Dimension "A":

Standard -0.1 to 0.35 mm (-0.0039 to 0.0138 in)

Wear limit 0.7 mm (0.028 in)

- c. If dimension "A" is larger than the wear limit, replace baulk ring.

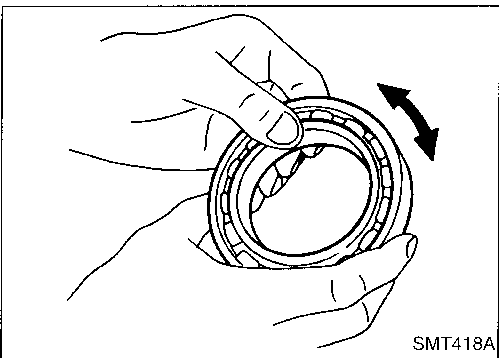

BEARINGS

- Make sure bearings roll freely and are free from noise, crack, pitting or wear.

ASSEMBLY

Gear Components

1. Install bearings into case components.

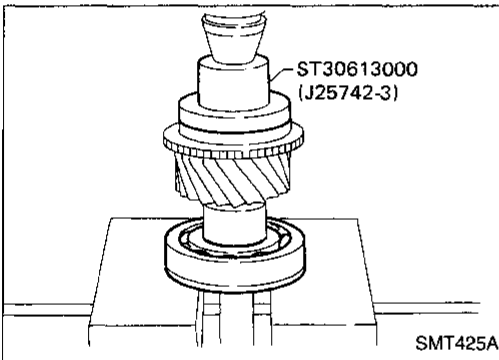
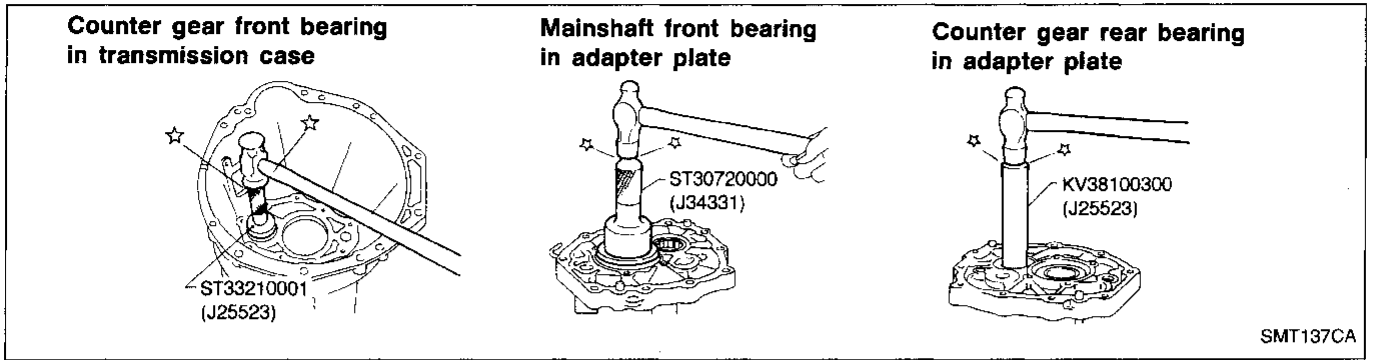

2. Install main drive gear bearing.
 - a. Press main drive gear bearing.
 - b. Install main drive gear spacer.

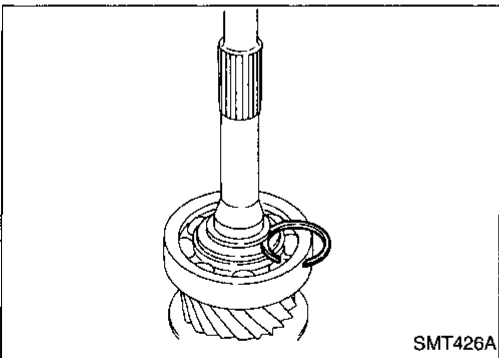

- c. Select proper main drive gear snap ring to minimize clearance of groove.

Allowable clearance of groove:

0 - 0.1 mm (0 - 0.004 in)

Main drive gear snap ring:

Refer to SDS, MT-31.

- d. Install selected snap ring on main drive gear.

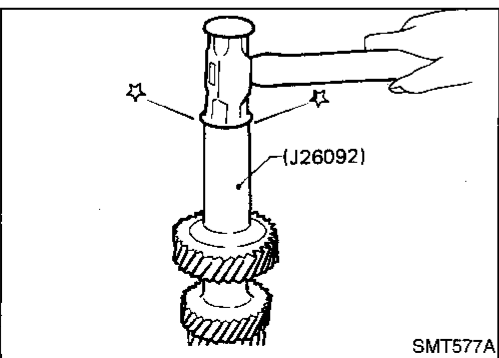

3. Install components on counter gear.
 - a. Install sub-gear components.
 - **When installing sub-gear snap ring, tap sub-gear snap ring into position on counter gear.**

GI

MA

EM

LC

EC

FE

CL

MT

AT

PD

FA

RA

BR

ST

RS

BT

HA

EL

IDX

ASSEMBLY

Gear Components (Cont'd)

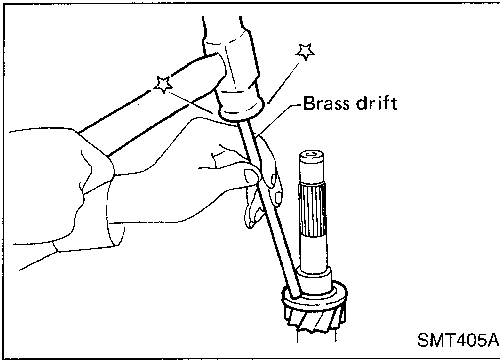

- b. Install counter gear rear thrust bearing.

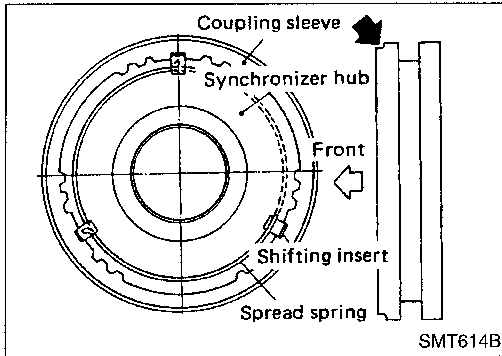

4. Install front side components on mainshaft.
a. Assemble 1st & 2nd synchronizer.

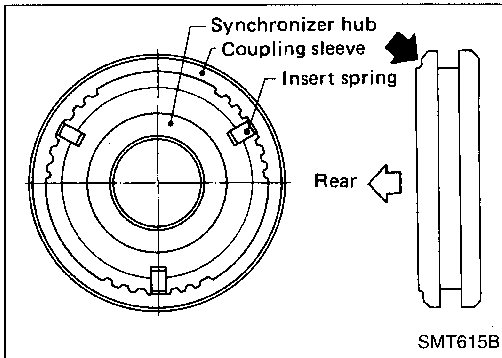

- b. Assemble 3rd & 4th synchronizer.

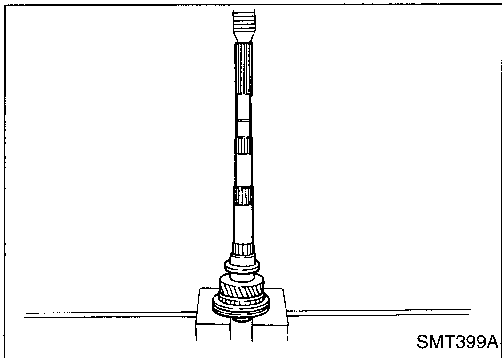

- c. Press on 3rd & 4th synchronizer assembly together with 3rd main gear and 3rd gear needle bearing.
- **Pay attention to direction of synchronizer assembly.**

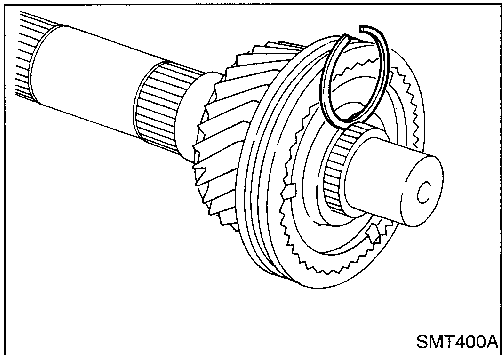

- d. Select proper snap ring to minimize clearance of groove.
Allowable clearance of groove:
0 - 0.1 mm (0 - 0.004 in)
Mainshaft front snap ring:
Refer to SDS, MT-31.
- e. Install selected snap ring on mainshaft.

ASSEMBLY

Gear Components (Cont'd)

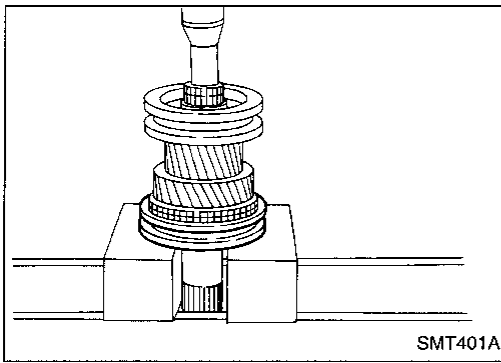

- f. Press on 1st & 2nd synchronizer assembly together with 2nd main gear and 2nd gear needle bearing.

GI

MA

EM

LC

EC

FE

CL

MT

AT

PD

FA

RA

BR

ST

RS

BT

HA

EL

IDX

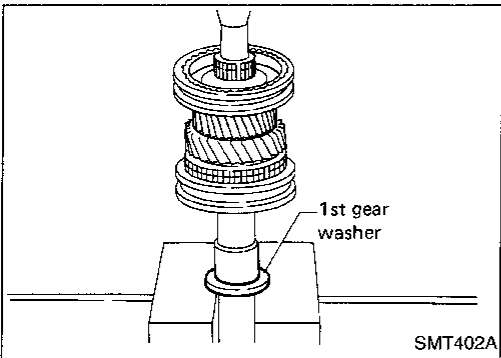

- g. Press on 1st gear bushing using 1st gear washer.
h. Install 1st main gear and needle bearing.

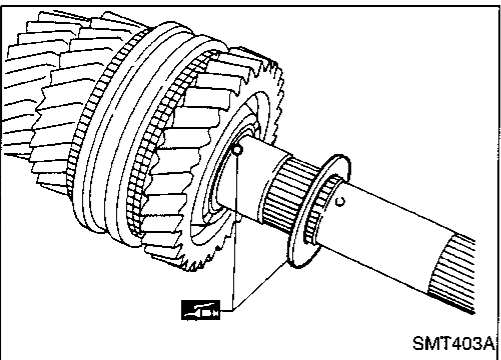

- i. Install steel ball and 1st gear washer.
• **Apply multi-purpose grease to steel ball and 1st gear washer before installing.**

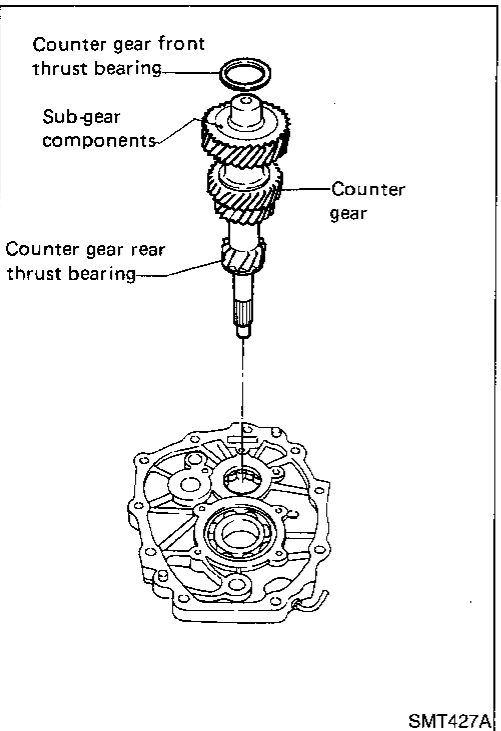

5. Select proper counter gear front bearing shim when replacing transmission case, counter gear, counter gear thrust bearing or sub-gear components.
a. Install counter gear with sub-gear components, counter gear front and rear thrust bearing on adapter plate.
b. Remove counter gear front bearing shim from transmission case.
c. Place adapter plate and counter gear assembly in transmission case (case inverted).

ASSEMBLY

Gear Components (Cont'd)

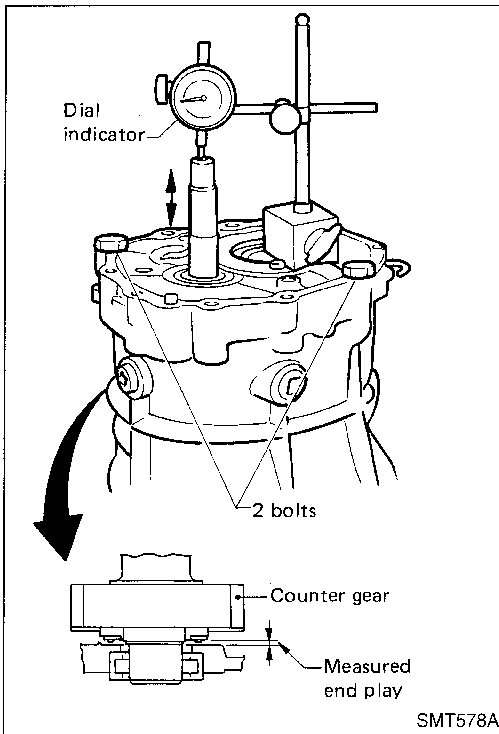

- d. Tighten adapter plate to transmission case using 2 bolts.
- e. Place dial indicator on rear end of counter gear.
- f. Move counter gear up and down and measure dial indicator deflection.
- g. Select proper shim using table in SDS as a guide.

Counter gear end play:

0.10 - 0.25 mm (0.0039 - 0.0098 in)

Table for selecting proper counter gear front bearing shim:

Refer to SDS, MT-31.

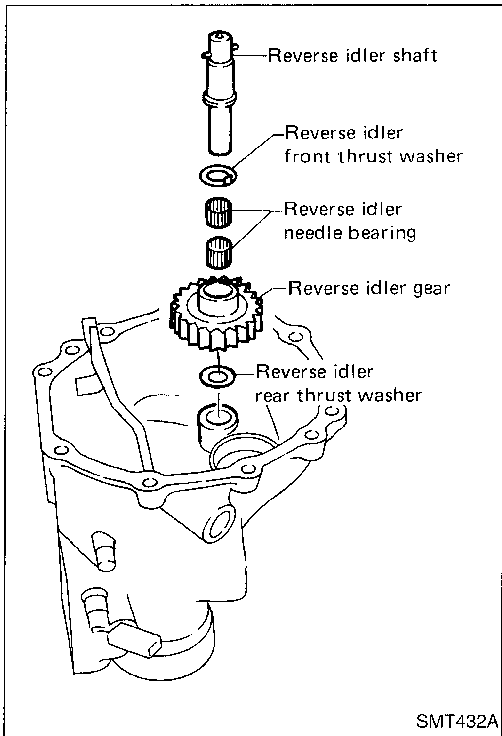

6. Select proper reverse idler rear thrust washer when replacing rear extension, reverse idler gear, reverse idler shaft or reverse idler thrust washer.
- a. Install reverse idler gear, reverse idler needle bearings, reverse idler thrust washers and reverse idler shaft into rear extension.
- **When replacing reverse idler rear thrust washer, install either A or B.**

Reverse idler rear thrust washer:

Refer to SDS, MT-31.

ASSEMBLY

Gear Components (Cont'd)

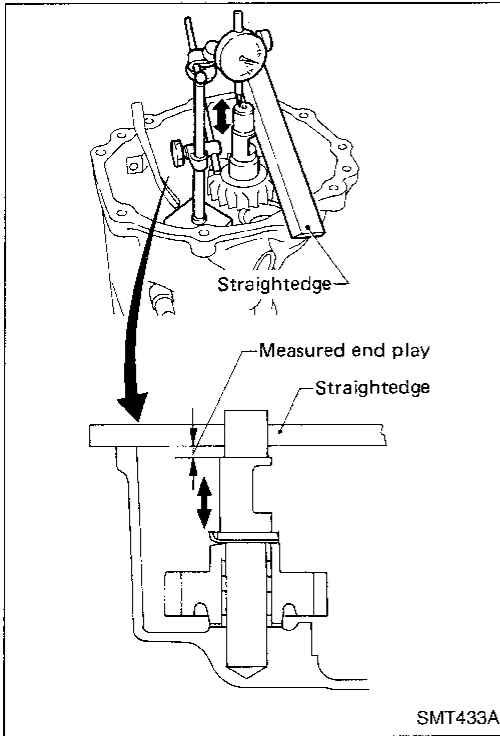

- b. Place dial indicator on front end of reverse idler shaft.
- c. Put straightedge on front surface of rear extension as a stopper of reverse idler shaft.
- d. Move reverse idler shaft up and down and measure reverse idler gear end play.

Reverse idler gear end play:

0.33 - 0.43 mm (0.0130 - 0.0169 in)

- e. If not within specification, replace reverse idler rear thrust washer with the other (A or B) and check again.

CI
MA
EM
LC
EC
FE
CL

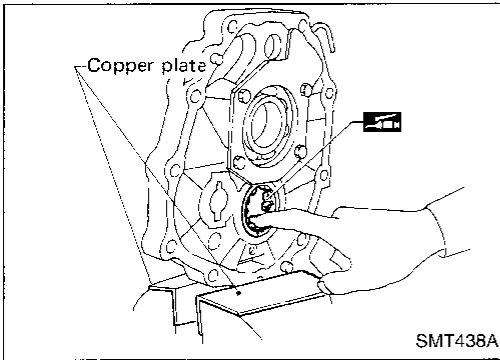

7. Install mainshaft and counter gear on adapter plate and main drive gear on mainshaft.
- a. Mount adapter plate on vise and apply multi-purpose grease to counter gear rear bearing.

MT
AT
PD
FA

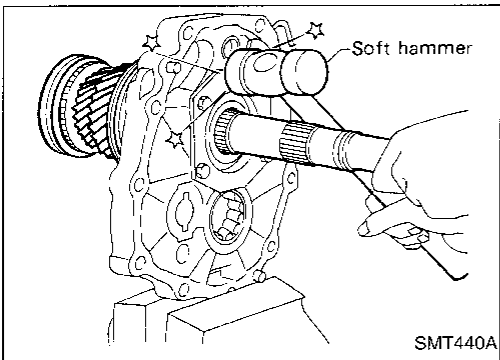

- b. Install mainshaft a little on mainshaft front bearing.
- **To allow for installation of counter gear, do not install mainshaft completely.**

RA
BR
ST
RS

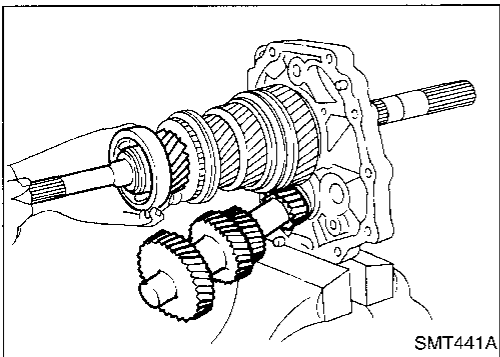

- c. Install counter gear on counter gear rear bearing and install main drive gear, pilot bearing and spacer on mainshaft.

BT
HA
EL
DX

ASSEMBLY

Gear Components (Cont'd)

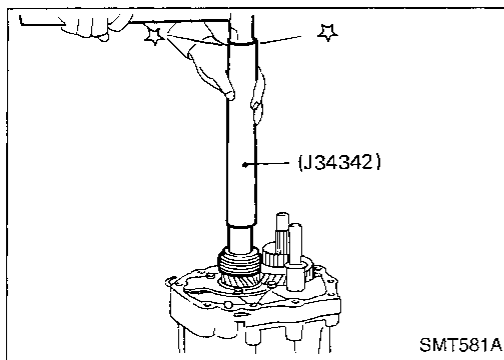

e. Install reverse gear bushing.

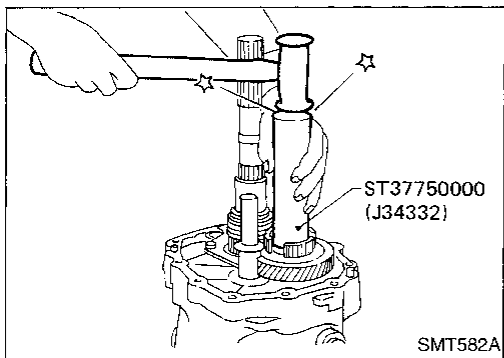

f. Install reverse cone.

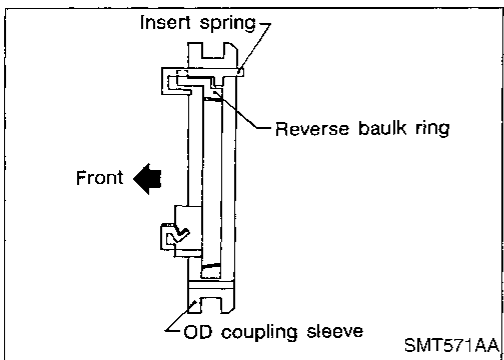

g. Install insert springs and reverse baulk ring on OD coupling sleeve. Then install them and OD baulk ring on OD counter gear.

- Pay attention to direction of OD coupling sleeve.

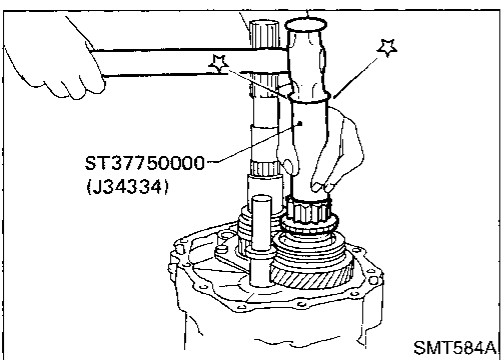
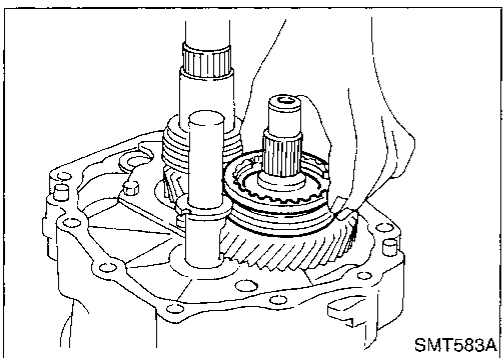

h. Install reverse counter gear.

GI

MA

EM

LC

EC

FE

CL

MT

AT

PD

FA

RA

BR

ST

RS

BT

HA

EL

IDX

ASSEMBLY

Gear Components (Cont'd)

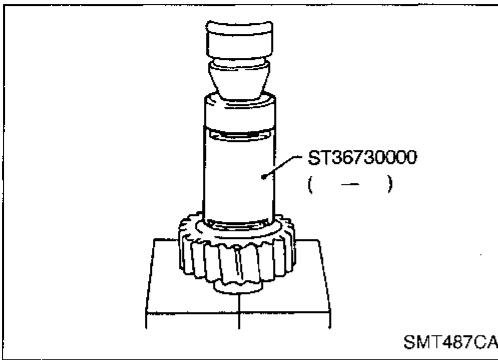

- i. Install sub-gear on reverse idler gear.
- j. Install reverse gear needle bearing and then install reverse main gear, reverse idler gear and reverse idler thrust washers.

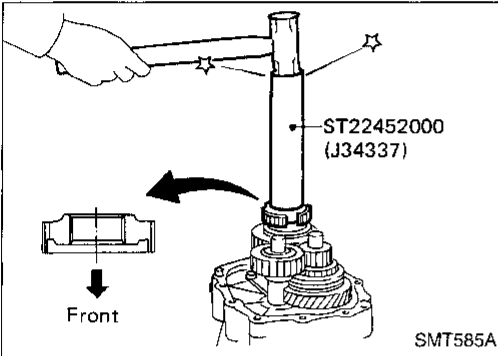

- k. Install reverse hub.
 - Pay attention to its direction.

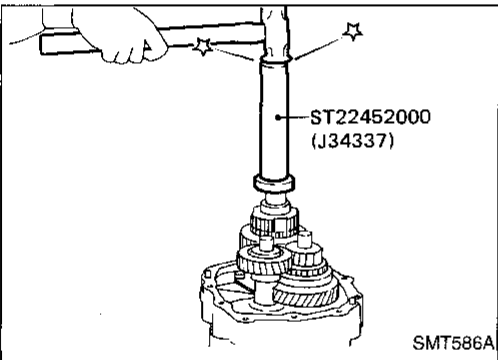

- l. Install mainshaft spacer and mainshaft rear bearing.
- m. Install speedometer drive gear.

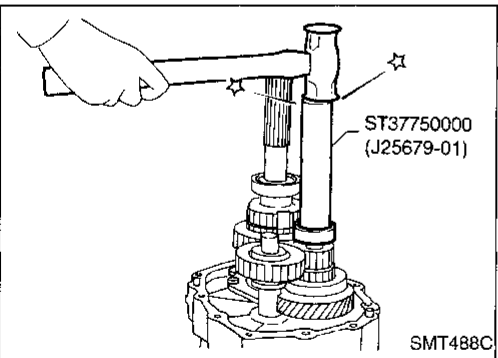

- n. Install counter gear rear end bearing.
- o. Separate adapter plate from transmission case and mount adapter plate on vise again.

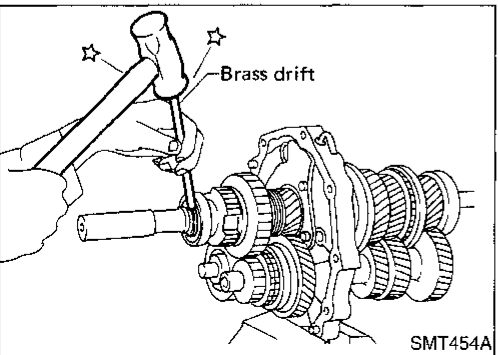

- p. Select proper mainshaft C-ring to minimize clearance of groove.
 - Allowable clearance of groove:**
0 - 0.1 mm (0 - 0.004 in)
 - Mainshaft C-ring:**
Refer to SDS, MT-31.
- q. Install selected C-ring, C-ring holder and mainshaft rear snap ring.

ASSEMBLY

Gear Components (Cont'd)

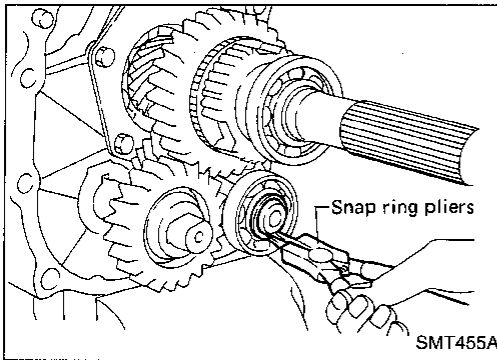

- r. Install spacer and then select proper counter gear rear snap ring to minimize clearance of groove.
Allowable clearance of groove:
0 - 0.1 mm (0 - 0.004 in)
Counter gear rear snap ring:
Refer to SDS, MT-31.
- s. Install selected counter gear rear snap ring.

GI

MA

EM

LC

EC

FE

CL

MT

AT

PD

FA

FA

BR

ST

RS

BT

HA

EL

IDX

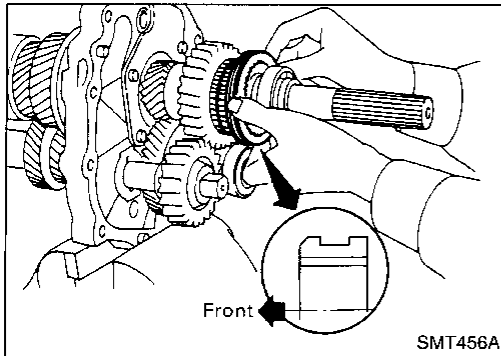

- t. Install reverse coupling sleeve.
• **Pay attention to its direction.**
- u. Measure each gear end play as a final check. Refer to "DISASSEMBLY", MT-13.

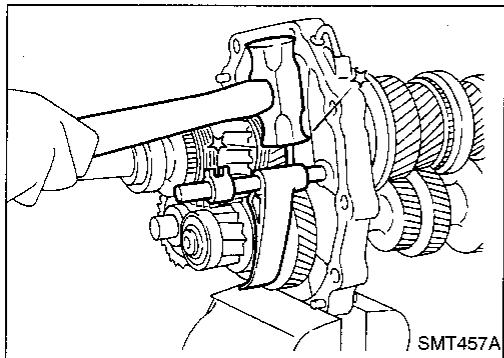

Shift Control Components

1. Install OD fork rod and OD shift fork. Then install retaining pin into OD shift fork.
2. Install 1st & 2nd, 3rd & 4th and reverse shift forks onto coupling sleeve.

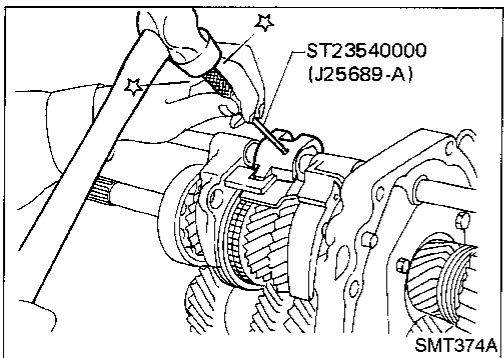

3. Install striking rod into hole of shift forks, striking lever and interlock and then install retaining pin into striking lever.
• **Make sure that striking rod moves smoothly.**

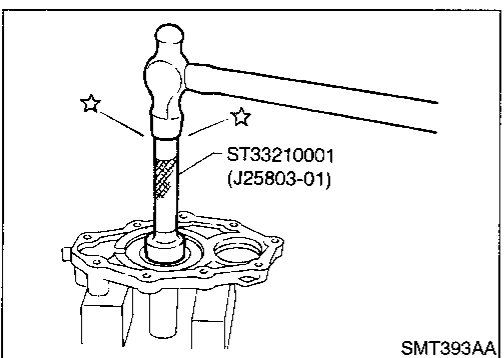

Case Components

1. Install front cover oil seal.
• **Apply multi-purpose grease to seal lip.**
2. Install selected counter gear front bearing shim onto transmission case.
• **Apply multi-purpose grease.**
3. Apply sealant to mating surface of transmission case.

ASSEMBLY

Case Components (Cont'd)

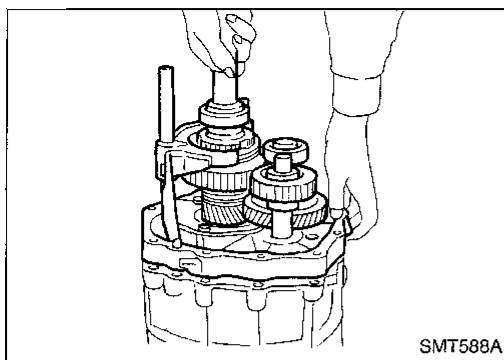

4. Install gear assembly onto transmission case.
5. Install check spring and check ball into interlock stopper.
 - **Apply multi-purpose grease to check ball.**

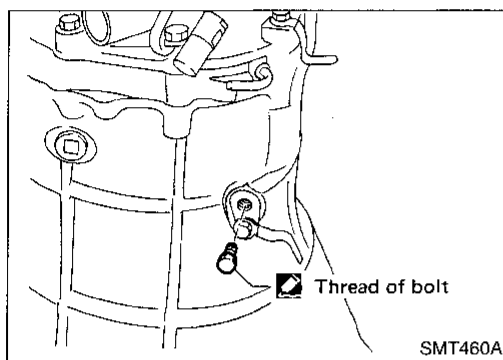

6. Install interlock stopper assembly and then tighten check ball plug.
 - **Apply sealant to thread of check ball plug.**

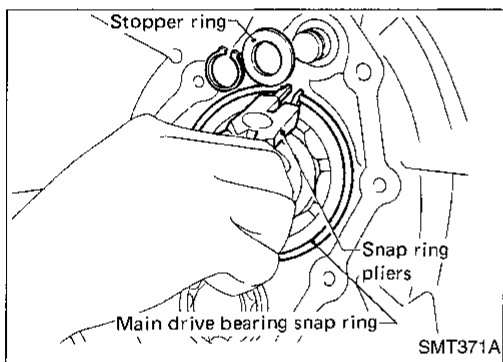

7. Install stopper ring and main drive bearing snap ring.

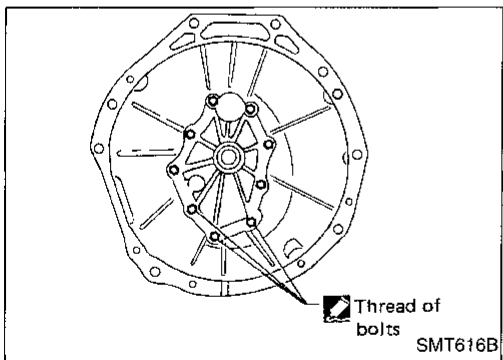

8. Install front cover and gasket.
 - **Apply sealant to thread of 3 bolts shown left.**
9. Apply sealant to mating surface of adapter plate.

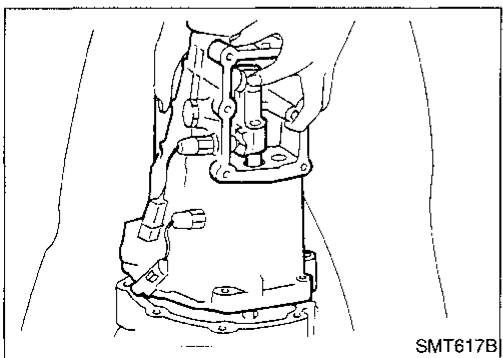

10. Install rear extension together with striking arm.

ASSEMBLY

Case Components (Cont'd)

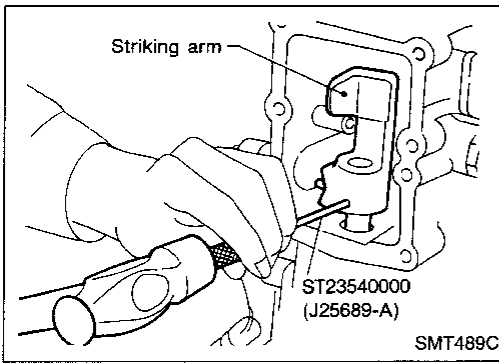

11. Install retaining pin into striking arm.

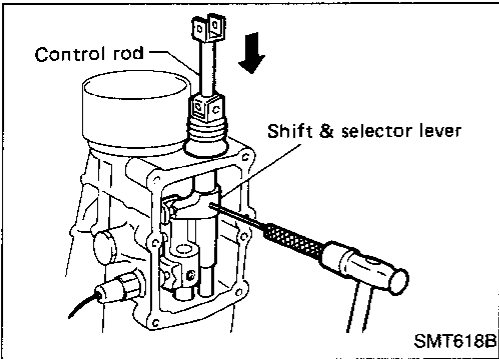

12. Install control rod.

- **Be careful not to damage control rod oil seal and dust cover.**

13. Install retaining pin into shift & selector lever.

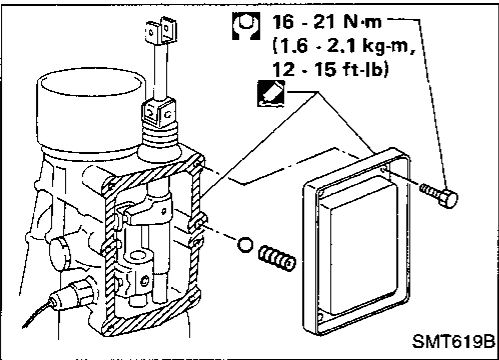

14. Install check spring and check ball and then install control housing.

- **Apply sealant to mating surface of rear extension.**

15. Tighten control housing upper cover bolts.

GI

MA

EM

LC

EC

FE

CL

MT

AT

PD

FA

RA

BR

ST

RS

BT

HA

EL

IDX

SERVICE DATA AND SPECIFICATIONS (SDS)

General Specifications

Engine	VG30DE, VG30DETT	
Transmission model	RS5R30A	
Shift pattern		
Synchromesh type	Warner	
Gear ratio		
	1st	3.214
	2nd	1.925
	3rd	1.302
	4th	1.000
	OD	0.752
	Reverse	3.369
Remarks	Sub-gear	Employed
	Double baulk ring type synchronizer	2nd and 3rd synchronizer

Number of teeth		
Main drive gear		23
Main gear		
1st		31
2nd		30
3rd		29
OD		24
Reverse		30
Counter drive gear		31
Counter gear		
1st		13
2nd		21
3rd		30
OD		43
Reverse		12
Reverse idler gear		22
Oil capacity	liter (US pt, Imp pt)	2.8 (5-7/8, 4-7/8)

Inspection and Adjustment

GEAR END PLAY

Gear	End play mm (in)
1st main gear	0.23 - 0.33 (0.0091 - 0.0130)
2nd main gear	0.23 - 0.33 (0.0091 - 0.0130)
3rd main gear	0.23 - 0.33 (0.0091 - 0.0130)
OD counter gear	0.23 - 0.33 (0.0091 - 0.0130)
Reverse main gear	0 - 0.11 (0 - 0.0043)
Counter gear	0.10 - 0.25 (0.0039 - 0.0098)
Reverse idler gear	0.33 - 0.43 (0.0130 - 0.0169)

2nd and 3rd baulk ring

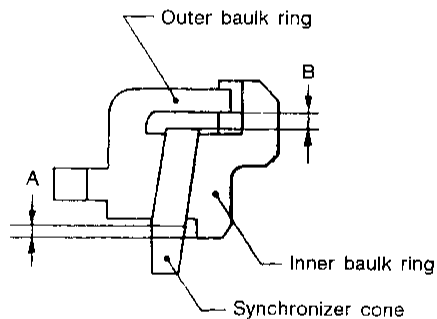

SMT044B

Unit: mm (in)

Dimension	Standard	Wear limit
A	0.6 - 1.1 (0.024 - 0.043)	0.2 (0.008)
B	0.7 - 0.9 (0.028 - 0.035)	0.2 (0.008)

CLEARANCE BETWEEN BAULK RING AND GEAR

1st, main drive and OD baulk ring

Unit: mm (in)

	Standard	Wear limit
1st	1.05 - 1.3 (0.0413 - 0.0512)	0.7 (0.028)
Main drive	1.05 - 1.3 (0.0413 - 0.0512)	0.7 (0.028)
OD	1.05 - 1.3 (0.0413 - 0.0512)	0.7 (0.028)

SERVICE DATA AND SPECIFICATIONS (SDS)

Inspection and Adjustment (Cont'd)

DISTANCE BETWEEN REAR SURFACE OF REVERSE CONE AND REVERSE BAULK RING

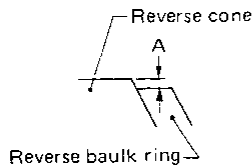

Unit: mm (in)

	Standard	Wear limit
Dimension "A"	-0.1 to 0.35 (-0.0039 to 0.0138)	0.7 (0.028)

AVAILABLE SNAP RING

Main drive gear snap ring

Allowable clearance 0 - 0.1 mm (0 - 0.004 in)

Thickness mm (in)	Part number
1.89 (0.0744)	32204-01G60
1.95 (0.0768)	32204-01G61
1.99 (0.0783)	32204-01G62
2.03 (0.0799)	32204-01G63
2.07 (0.0815)	32204-01G64
2.11 (0.0831)	32204-01G65

Mainshaft front snap ring

Allowable clearance 0 - 0.1 mm (0 - 0.004 in)

Thickness mm (in)	Part number
1.99 (0.0783)	32204-01G62
2.03 (0.0799)	32204-01G63
2.07 (0.0815)	32204-01G64
2.11 (0.0831)	32204-01G65
2.15 (0.0846)	32204-01G66
2.19 (0.0862)	32204-01G67

Counter gear rear snap ring

Allowable clearance 0 - 0.1 mm (0 - 0.004 in)

Thickness mm (in)	Part number
1.32 (0.0520)	32236-01G00
1.38 (0.0543)	32236-01G01
1.44 (0.0567)	32236-01G02
1.50 (0.0591)	32236-01G03
1.56 (0.0614)	32236-01G04
1.62 (0.0638)	32236-01G05
1.68 (0.0661)	32236-01G06
1.74 (0.0685)	32236-01G07

AVAILABLE C-RING

Mainshaft C-ring

Allowable clearance 0 - 0.1 mm (0 - 0.004 in)

Thickness mm (in)	Part number	Thickness mm (in)	Part number
2.63 (0.1035)	32348-01G15	3.19 (0.1256)	32348-01G07
2.70 (0.1063)	32348-01G00	3.26 (0.1283)	32348-01G08
2.77 (0.1091)	32348-01G01	3.33 (0.1311)	32348-01G09
2.84 (0.1118)	32348-01G02	3.40 (0.1339)	32348-01G10
2.91 (0.1146)	32348-01G03	3.47 (0.1366)	32348-01G11
2.98 (0.1173)	32348-01G04	3.54 (0.1394)	32348-01G12
3.05 (0.1201)	32348-01G05	3.61 (0.1421)	32348-01G13
3.12 (0.1228)	32348-01G06	3.68 (0.1449)	32348-01G14

AVAILABLE SHIM AND WASHER

Table for selecting proper counter gear front bearing shim

Dial indication deflection mm (in)	Thickness of proper washer mm (in)	Part number
0.93 - 1.02 (0.0366 - 0.0402)	0.8 (0.031)	32218-01G00
1.01 - 1.10 (0.0398 - 0.0433)	0.88 (0.0346)	32218-01G11
1.09 - 1.18 (0.0429 - 0.0465)	0.96 (0.0378)	32218-01G12
1.17 - 1.26 (0.0461 - 0.0496)	1.04 (0.0409)	32218-01G13
1.25 - 1.34 (0.0492 - 0.0528)	1.12 (0.0441)	32218-01G14
1.33 - 1.42 (0.0524 - 0.0559)	1.2 (0.047)	32218-01G04
1.41 - 1.50 (0.0555 - 0.0591)	1.28 (0.0504)	32218-01G15
1.49 - 1.58 (0.0587 - 0.0622)	1.36 (0.0535)	32218-01G16
1.57 - 1.66 (0.0618 - 0.0654)	1.44 (0.0567)	32218-01G17

Reverse idler rear thrust washer

Thickness mm (in)		Part number
A	1.97 (0.0776)	32284-01G10
B	2.07 (0.0815)	32284-01G11