

A  
B  
C

# SECTION PS

## POWER STEERING SYSTEM

### CONTENTS

<p><b>PRECAUTIONS</b> ..... 2</p> <p style="padding-left: 20px;">Precautions for Supplemental Restraint System (SRS) "AIR BAG" and "SEAT BELT PRE-TENSIONER" ..... 2</p> <p style="padding-left: 20px;">Precautions for Battery Service ..... 2</p> <p style="padding-left: 20px;">Precautions for Steering System ..... 2</p> <p><b>PREPARATION</b> ..... 3</p> <p style="padding-left: 20px;">Special Service Tools (SST) ..... 3</p> <p style="padding-left: 20px;">Commercial Service Tools ..... 4</p> <p><b>NOISE, VIBRATION AND HARSHNESS (NVH)</b></p> <p><b>TROUBLESHOOTING</b> ..... 5</p> <p style="padding-left: 20px;">NVH Troubleshooting Chart ..... 5</p> <p><b>POWER STEERING FLUID</b> ..... 6</p> <p style="padding-left: 20px;">Checking Fluid Level ..... 6</p> <p style="padding-left: 20px;">Checking Fluid Leakage ..... 6</p> <p style="padding-left: 20px;">Air Bleeding Hydraulic System ..... 6</p> <p><b>STEERING WHEEL</b> ..... 8</p> <p style="padding-left: 20px;">On-Vehicle Inspection and Service ..... 8</p> <p style="padding-left: 40px;">CHECKING CONDITION OF INSTALLATION ..... 8</p> <p style="padding-left: 40px;">CHECKING STEERING WHEEL PLAY ..... 8</p> <p style="padding-left: 40px;">CHECKING NEUTRAL POSITION ON STEERING WHEEL ..... 8</p> <p style="padding-left: 40px;">CHECKING STEERING WHEEL TURNING FORCE ..... 8</p> <p style="padding-left: 40px;">CHECKING FRONT WHEEL TURNING ANGLE... 8</p> <p style="padding-left: 20px;">Removal and Installation ..... 9</p> <p><b>STEERING COLUMN</b> ..... 10</p> <p style="padding-left: 20px;">Removal and Installation ..... 10</p> <p style="padding-left: 40px;">REMOVAL ..... 10</p> <p style="padding-left: 40px;">INSPECTION AFTER REMOVAL ..... 13</p> <p style="padding-left: 40px;">INSTALLATION ..... 13</p> <p style="padding-left: 40px;">INSPECTION AFTER INSTALLATION ..... 14</p> <p style="padding-left: 20px;">Disassembly and Assembly ..... 15</p> <p style="padding-left: 40px;">DISASSEMBLY ..... 15</p> <p style="padding-left: 40px;">INSPECTION AFTER REMOVAL ..... 16</p> <p style="padding-left: 40px;">ASSEMBLY ..... 16</p>	<p><b>POWER STEERING GEAR AND LINKAGE</b> ..... 17</p> <p style="padding-left: 20px;">Removal and Installation ..... 17</p> <p style="padding-left: 40px;">REMOVAL ..... 17</p> <p style="padding-left: 40px;">INSTALLATION ..... 18</p> <p><b>POWER STEERING GEAR</b> ..... 19</p> <p style="padding-left: 20px;">Component ..... 19</p> <p style="padding-left: 20px;">Disassembly and Assembly ..... 20</p> <p style="padding-left: 40px;">DISASSEMBLY ..... 20</p> <p style="padding-left: 40px;">INSPECTION AFTER DISASSEMBLY ..... 22</p> <p style="padding-left: 40px;">ASSEMBLY ..... 23</p> <p><b>POWER STEERING OIL PUMP</b> ..... 29</p> <p style="padding-left: 20px;">On-Vehicle Service ..... 29</p> <p style="padding-left: 40px;">CHECKING RELIEF OIL PRESSURE ..... 29</p> <p style="padding-left: 20px;">Removal and Installation ..... 29</p> <p style="padding-left: 40px;">REMOVAL ..... 29</p> <p style="padding-left: 40px;">INSTALLATION ..... 30</p> <p style="padding-left: 20px;">Disassembly and Assembly ..... 30</p> <p style="padding-left: 40px;">INSPECTION AFTER DISASSEMBLY ..... 30</p> <p style="padding-left: 40px;">DISASSEMBLY ..... 30</p> <p style="padding-left: 40px;">INSPECTION AFTER DISASSEMBLY ..... 31</p> <p style="padding-left: 40px;">ASSEMBLY ..... 31</p> <p><b>HYDRAULIC LINE</b> ..... 34</p> <p style="padding-left: 20px;">Removal and Installation ..... 34</p> <p><b>SERVICE DATA AND SPECIFICATIONS (SDS)</b> ..... 36</p> <p style="padding-left: 20px;">Steering Wheel ..... 36</p> <p style="padding-left: 20px;">Steering Angle ..... 36</p> <p style="padding-left: 20px;">Steering Column ..... 36</p> <p style="padding-left: 20px;">Steering Outer Socket and Inner Socket ..... 36</p> <p style="padding-left: 20px;">Steering Gear ..... 37</p> <p style="padding-left: 20px;">Oil Pump ..... 37</p> <p style="padding-left: 20px;">Steering Fluid ..... 37</p>
---	--

A  
B  
C  
D  
E  
F  
PS  
H  
I  
J  
K  
L  
M

# PRECAUTIONS

## PRECAUTIONS

PFP:00001

### Precautions for Supplemental Restraint System (SRS) “AIR BAG” and “SEAT BELT PRE-TENSIONER”

AGS00084

The Supplemental Restraint System such as “AIR BAG” and “SEAT BELT PRE-TENSIONER”, used along with a front seat belt, helps to reduce the risk or severity of injury to the driver and front passenger for certain types of collision. This system includes seat belt switch inputs and dual stage front air bag modules. The SRS system uses the seat belt switches to determine the front air bag deployment, and may only deploy one front air bag, depending on the severity of a collision and whether the front occupants are belted or unbelted. Information necessary to service the system safely is included in the SRS and SB section of this Service Manual.

#### **WARNING:**

- To avoid rendering the SRS inoperative, which could increase the risk of personal injury or death in the event of a collision which would result in air bag inflation, all maintenance must be performed by an authorized NISSAN/INFINITI dealer.
- Improper maintenance, including incorrect removal and installation of the SRS, can lead to personal injury caused by unintentional activation of the system. For removal of Spiral Cable and Air Bag Module, see the SRS section.
- Do not use electrical test equipment on any circuit related to the SRS unless instructed to in this Service Manual. SRS wiring harnesses can be identified by yellow and/or orange harnesses or harness connectors.

### Precautions for Battery Service

AGS000A9

Before disconnecting the battery, lower both the driver and passenger windows. This will prevent any interference between the window edge and the vehicle when the door is opened/closed. During normal operation, the window slightly raises and lowers automatically to prevent any window to vehicle interference. The automatic window function will not work with the battery disconnected.

### Precautions for Steering System

AGS0009Q

- Before disassembly, thoroughly clean the outside of the unit.
- Disassembly should be done in a clean work area. It is important to prevent the internal parts from becoming contaminated by dirt or other foreign matter.
- For easier and proper assembly, place disassembled parts in order on a parts rack.
- Use nylon cloth or paper towels to clean the parts; common shop rags can leave lint that might interfere with their operation.
- Before inspection or reassembly, carefully clean all parts with a general purpose, non-flammable solvent.
- Before assembly, apply a coat of recommended Genuine NISSAN PSF or equivalent to hydraulic parts. Petroleum jelly may be applied to O-rings and seals. Do not use any grease.
- Replace all gaskets, seals and O-rings. Avoid damaging O-rings, seals and gaskets during installation. Perform functional tests whenever designated.

# PREPARATION

## PREPARATION

PFP:00002

### Special Service Tools (SST)

AGS0001V

The actual shapes of Kent-Moore tools may differ from those of special service tools illustrated here.

A  
B  
C  
D  
E  
F  
PS  
H  
I  
J  
K  
L  
M

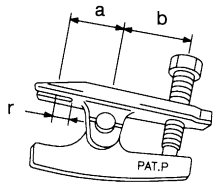
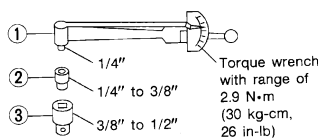
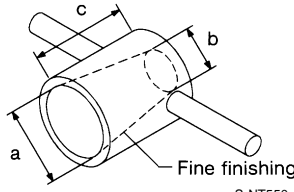
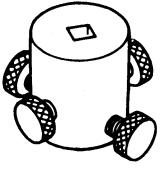
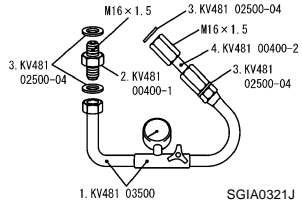
Tool number (Kent-Moore No.) Tool name	Description
HT72520000 (J25730-A) Ball joint remover a: 33 mm (1.30 in) b: 50 mm (1.97 in) r: 11.5 mm (0.453 in)	 <p style="text-align: center;">NT546</p> Removing outer socket ball joint
ST3127S000 (See J25765-A) Preload gauge 1. GG9103000 (J25765-A) Torque wrench 2. HT62940000 ( - ) Socket adapter 3. HT62900000 ( - ) Socket adapter	 <p style="text-align: center;">S-NT541</p> Inspecting of sliding torque, steering torque, and rotating torque for ball joint
KV48104400 ( - ) Teflon ring correcting tool a: 50 mm (1.97 in) dia. b: 36 mm (1.42 in) dia. c: 100 mm (3.94 in)	 <p style="text-align: center;">S-NT550</p> Installing of rack Teflon ring
KV48103404 ( - ) Torque adapter	 <p style="text-align: center;">ZZA0824D</p> Inspecting rotating torque
1. KV48103500 (J26357 and J26357-10) Pressure gauge 2. KV48100400-1 ( - ) Connector 3. KV48102500-04 ( - ) Washer 4. KV48100410 ( - ) Joint	 <p style="text-align: center;">SGIA0321J</p> Measuring oil pump relief pressure

# PREPARATION

## Commercial Service Tools

AGS0001W

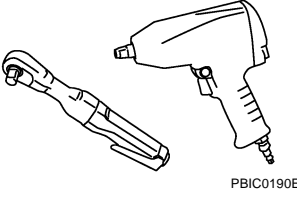
Tool name	Description
<p data-bbox="172 357 284 383">Power tool</p>  <p data-bbox="836 463 906 480">PBIC0190E</p>	<p data-bbox="991 357 1347 383">Removing oil pump and wheel nuts</p>



# POWER STEERING FLUID

## POWER STEERING FLUID

PFP:KLF20

### Checking Fluid Level

AGS0001Y

- Stop engine before performing a fluid level check.
- Ensure that fluid level is between the MAX range and MIN level.
- Because fluid level differs within the HOT range and the COLD range, check it carefully.

**HOT** : Fluid temperatures from 50 to 80 °C (122 to 176°F)

**COLD** : Fluid temperatures from 0 to 30°C (32 to 86°F)

#### CAUTION:

- Do not overfill the MAX level.
- Do not reuse any used power steering fluid.
- Recommended fluid is Genuine NISSAN PSF or equivalent.

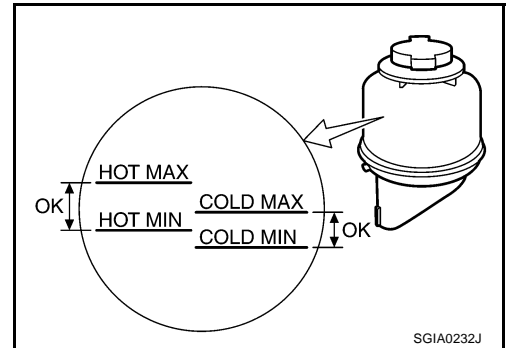

### Checking Fluid Leakage

AGS0001Z

Check that hydraulic piping lines for improper attachment and for leaks, cracks, damage, loose connections, chafing or deterioration.

1. Run engine until fluid temperature reaches 50 to 80° C (122 to 176°F) in reservoir tank. Keep engine speed idle.
2. Turn steering wheel right-to-left several times.
3. Hold steering wheel at each "lock" position for five seconds to check fluid leakage.

#### CAUTION:

**Do not hold steering wheel in a locked position for more than 10 seconds. (There is the possibility that oil pump may be damaged.)**

4. If fluid leakage at connections is noticed, then loosen flare nut and then retighten. Do not over tighten connector as this can damage O-ring, washer and connector.
5. If fluid leakage at the connectors is noticed, then loosen the flare nut and retighten it.
6. Check steering gear boots for accumulation of fluid indicating a from steering gear.

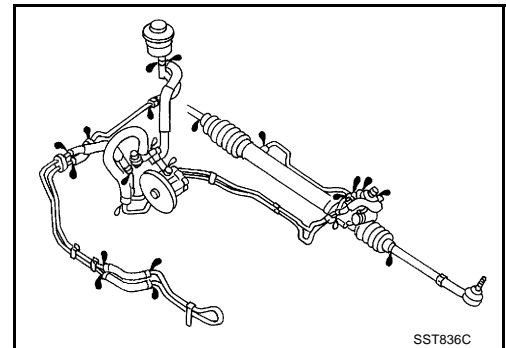

### Air Bleeding Hydraulic System

AGS00020

Incomplete air bleeding causes the following. When this happens, bleed air again.

- Generation of air bubbles in reservoir tank
- Generation of clicking noise in oil pump
- Excessive buzzing in oil pump

#### NOTE:

When vehicle is stationary or while steering wheel is being turned slowly, some noise may be heard from oil pump or gear. This noise is normal and does not affect any system.

1. Stop engine, and then turn steering wheel fully to right and left several times.

#### CAUTION:

**Do not allow steering fluid reservoir tank to go below the low-level line. Check tank frequenter and add fluid as needed.**

2. Run engine at idle speed. Turn steering wheel fully to the right and then fully to the left, and keep for about three seconds. Then check whether a fluid leakage has occurred.
3. Repeat the 2nd procedure several times at about three seconds intervals.

#### CAUTION:

**Do not hold steering wheel in the locked position more than 10 seconds. (There is the possibility that oil pump may be damaged.)**

4. Check generation of air bubbles and cloud in the fluid.
5. If air bubbles and the cloud don't fade, stop engine, hold air bleeding until air bubbles and the cloud fade. Perform the 2nd and the 3rd procedures again.

# POWER STEERING FLUID

---

6. Stop engine, check fluid level.

A

B

C

D

E

F

**PS**

H

I

J

K

L

M

# STEERING WHEEL

## STEERING WHEEL

PFP:48430

### On-Vehicle Inspection and Service CHECKING CONDITION OF INSTALLATION

AGS00021

- Check installation condition of steering gear assembly, front suspension, axle and steering column.
- Check if movement exists when steering wheel is moved up and down, to the left and right and to the axial direction.

**End play of the axle direction for steering wheel:**  
**0 mm (0 in)**

- Check if the mounting bolts for steering gear assembly are loose or not. Refer to [PS-17, "POWER STEERING GEAR AND LINK-AGE"](#).

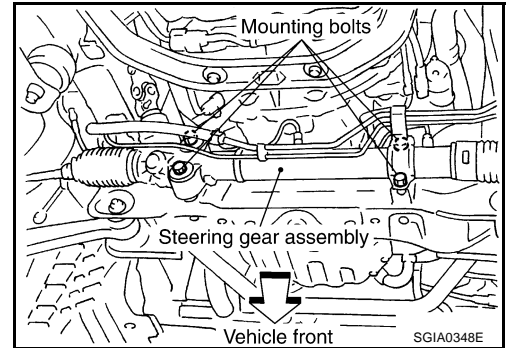

### CHECKING STEERING WHEEL PLAY

1. Set tires to the straight ahead, start engine, then turn steering wheel to the left and right lightly, and measure steering wheel movement on the outer circumference when steering wheel is turned up to the point where tires start moving.

**Steering wheel play on the circumference : 0 - 35 mm (0 - 1.38 in)**

### CHECKING NEUTRAL POSITION ON STEERING WHEEL

- Check neutral position on steering wheel after confirming that front wheel alignment is correct. Refer to [FSU-21, "SERVICE DATA"](#).
1. Set the vehicle to the straight ahead-direction, check if steering wheel is in the neutral position.
  2. If it is not in the neutral position, remove steering wheel and reinstall it correctly.
  3. If the neutral position cannot adjust in the two teeth of steering gear assembly, loosen tie-rod lock nuts of steering outer sockets, then adjust tie-rods by the same amount in the opposite direction.

### CHECKING STEERING WHEEL TURNING FORCE

1. Park vehicle on a level and dry surface, set parking brake.
2. Remove driver air bag module from steering wheel. Refer to [SRS-37, "DRIVER AIR BAG MODULE"](#).
3. Start engine at idle, make steering fluid reach to normal operating temperature [50 to 80°C (122 to 176°F)], then check steering wheel turning torque with pre-load gauge (SST).

**Turning torque : 7.45 N·m (0.76 kg·m, 66 in·lb)**

4. If steering wheel turning force is out of the specification, check relief hydraulic pressure of oil pump. Refer to [PS-29, "POWER STEERING OIL PUMP"](#).

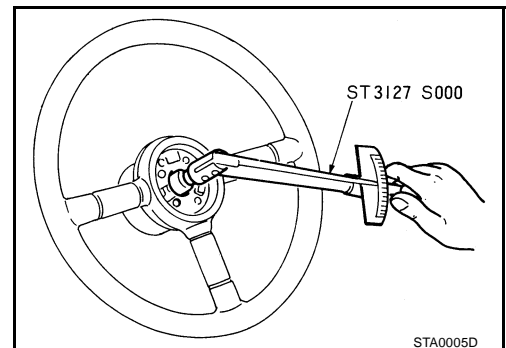

### CHECKING FRONT WHEEL TURNING ANGLE

- Check front wheel turning angle after the toe-in inspection. Place front wheels on turning radius gauges and rear wheels on stands so that vehicle can be level. Check the maximum inner and outer wheel turning angles for LH and RH road wheels.

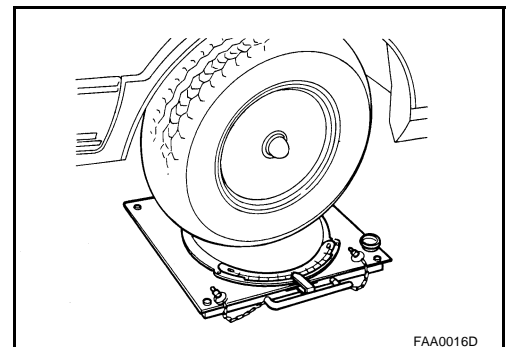



# STEERING WHEEL

- Start engine and run at idle, turn steering wheel all the way right and left, measure the turning angle.

<b>Inner wheel (Angle: A)</b>	<b>Minimum</b>	<b>35° 55' (35.9°)</b>
	<b>Nominal</b>	<b>38° 55' (38.9°)</b>
	<b>Maximum</b>	<b>39° 55' (39.9°)</b>
<b>Outer wheel (Angle: B)</b>	<b>Nominal</b>	<b>30° 40' (30.7°)</b>

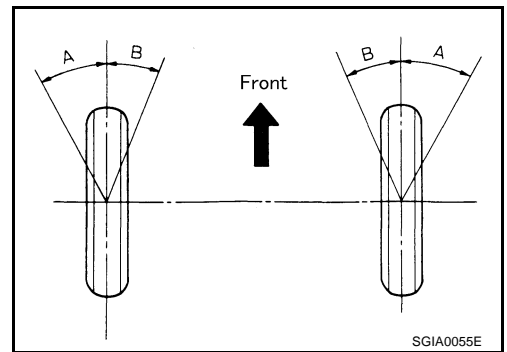

- If it is not within specification, measure rack strokes.

**Rack stroke "L" : 64.5 mm (2.54 in)**

- If rack stroke is out of specification, disassemble steering gear assembly to check rack stroke.
- Any turning angles are not adjustable. If any of steering angles are out of the specification, check if the following parts are wear or damaged.
  - Steering gear
  - Steering column
  - Front suspension components
 If found that they are worn or damaged, replace them with new ones respectively.

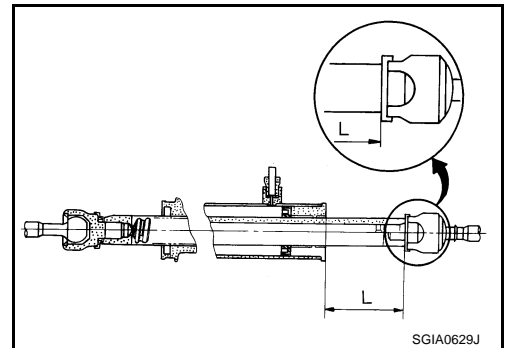

## Removal and Installation

Refer to [PS-10, "STEERING COLUMN"](#) .

AGS00022

# STEERING COLUMN

## STEERING COLUMN

PF-P:48810

### Removal and Installation

AGS00023

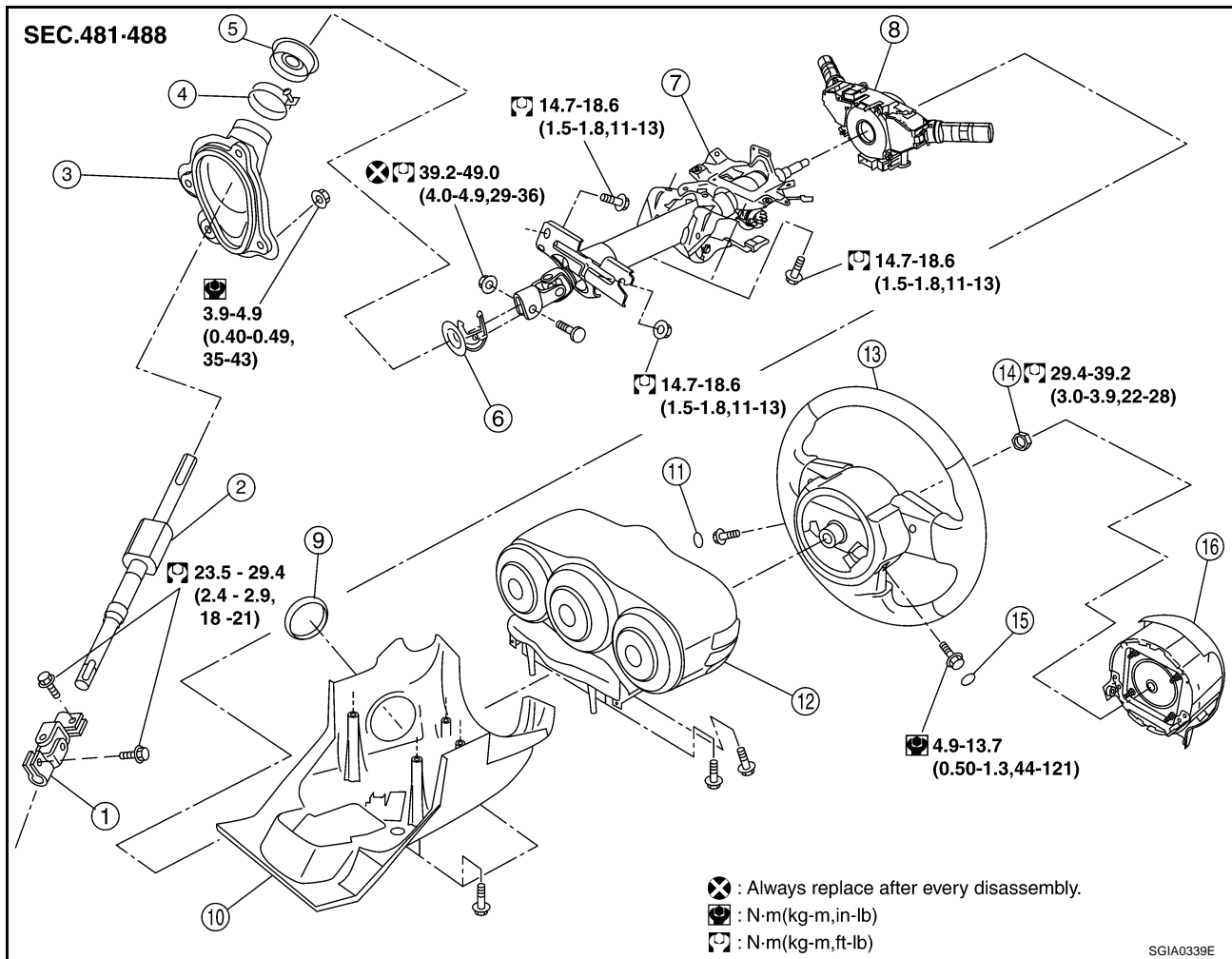

- |                             |                                      |  |
|-----------------------------|--------------------------------------|--|
| 1. Lower joint              | 2. Lower shaft                       | 3. Hole cover                              |
| 4. Clamp                    | 5. Hole cover seal                   | 6. Collar                                  |
| 7. Steering column assembly | 8. Combination switch & spiral cable | 9. Escutcheon                              |
| 10. Column lower cover      | 11. Right lid                        | 12. Combination meter & column upper cover |
| 13. Steering wheel          | 14. Steering wheel lock nut          | 15. Left lid                               |
| 16. Driver air bag module   |                                      |  |

### CAUTION:

- Care must be taken not to give axial impact to steering column assembly during removal and installation.
- Care must be taken not to move steering gear during removal of steering column assembly.

### REMOVAL

1. Set vehicle to the straight ahead-direction.
2. Remove driver air bag module from steering wheel. Refer to [SRS-37, "DRIVER AIR BAG MODULE"](#).
3. Disconnect steering switch connector, remove steering wheel lock nut, then remove steering wheel.
4. Remove dash side finisher (LH). Refer to [IP-11, "Removal and Installation"](#).
5. Remove instrument driver panel lower. Refer to [IP-11, "Removal and Installation"](#).
6. Remove column lower cover and combination meter (which is connected with steering column upper cover) from steering column assembly. Refer to [DI-4, "COMBINATION METERS"](#).

# STEERING COLUMN

7. Remove combination switch & spiral cable from steering column assembly. Refer to [SRS-39, "Removal and Installation"](#).
8. Disconnect the following connector from steering column assembly.
  - Steering lock harness connector
  - Ignition switch harness connector
  - Key switch harness connector
9. Remove control unit with VDC/TCS/ABS. Refer to [BRC-150, "VDC/TCS/ABS CONTROL UNIT"](#).
10. Disconnect brake switch harness connector.
11. Remove steering column shaft from lower shaft in the following procedure.
  - a. Remove lock nut from yoke.

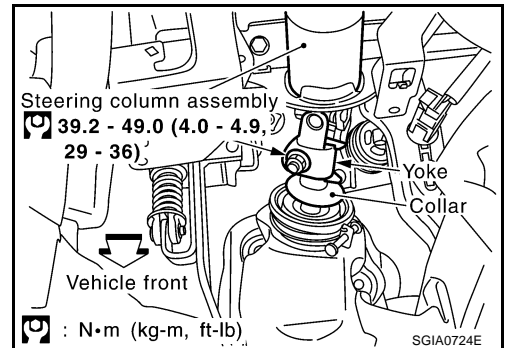
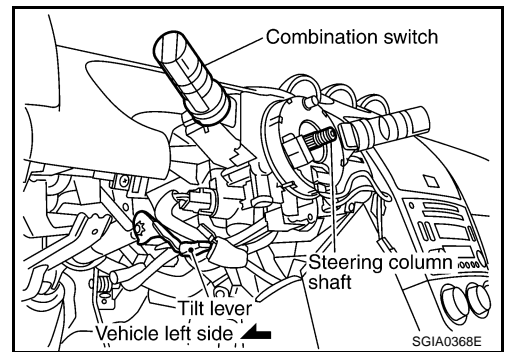

- b. Turn steering wheel to the right to appear the head of the bolt.
  - c. Remove the fixed part of collar for bolt to the outside of its head, remove bolt.

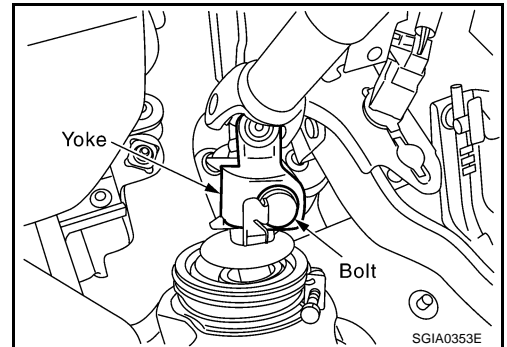

- d. Remove the set lib of steering column assembly side from yoke, push it equal to the thick part of yoke.

**NOTE:**

- Because collar is set in lower shaft, if the set lib is pushed (action), joint center will be lifted in the opposite direction (reaction), and then the set lib will be in squeezed to the thick part of yoke.

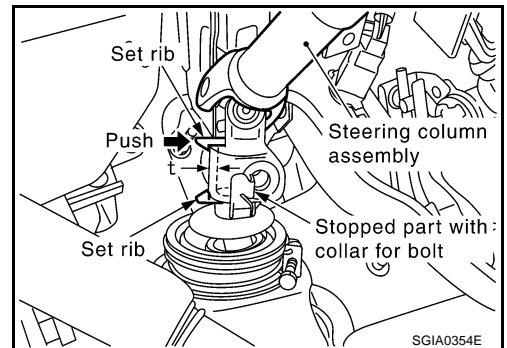

A  
B  
C  
D  
E  
F  
PS  
H  
I  
J  
K  
L  
M

# STEERING COLUMN

- e. Yoke will be removed from collar, when steering column assembly is lifted about 45° oblique upward.

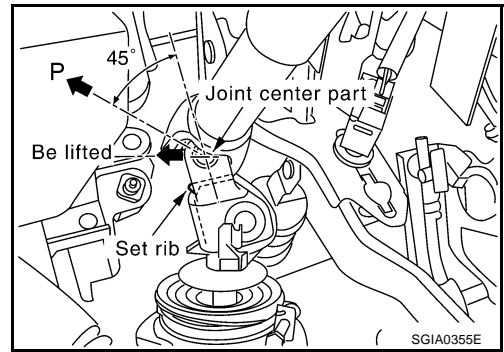

- f. Collar remains on lower shaft.

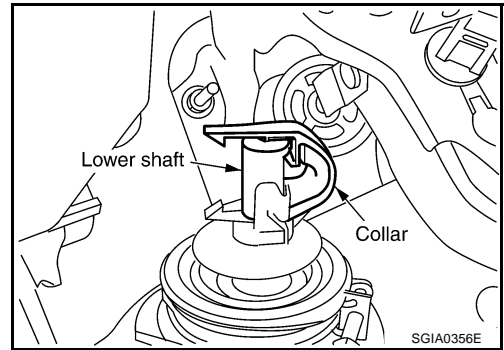

12. Remove bolts and nut from steering member, remove steering column assembly from steering member.
13. Remove collar from lower shaft.
14. Remove hole cover seal from lower shaft.
15. Remove mounting bolts, then remove hole cover from panel.

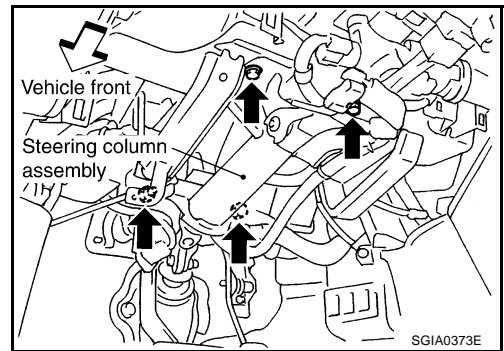

16. Raise vehicle, then loosen bolt for lower yoke of lower joint and remove joint together with lower shaft.

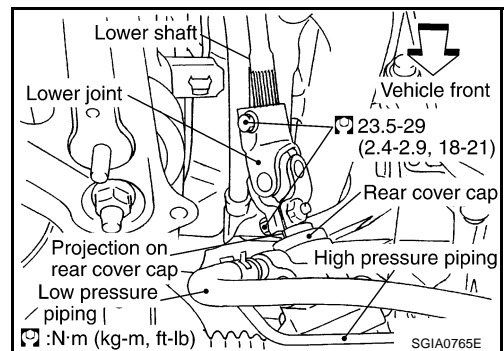

# STEERING COLUMN

## INSPECTION AFTER REMOVAL

- Check if there is something wrong with jacket tube of steering column assembly and collar etc. And then if they are damaged, replace with new one.
- If vehicle has a collision light shocked, check column length "L" as shown in the figure. Then if it is out of the specified value, replace with new one.

### Specified value

#### Steering column length "L":

**568 mm (22.36 in)**

- Check the turning torque of steering column with preload gauge (SST). If it is out of the specified value, repair it or replace with new one.

### Specified value

**Turning torque : 0 - 0.2 N·m (0 - 0.021 kg·m, 0 - 1 in·lb)**

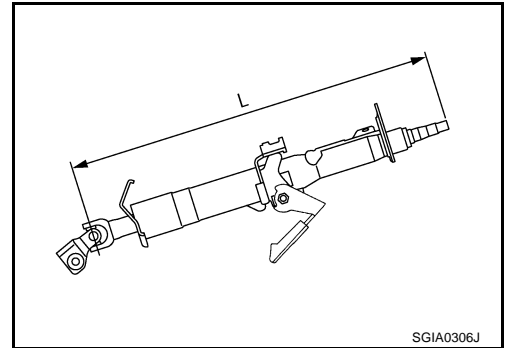

## INSTALLATION

1. Install collar to lower shaft.

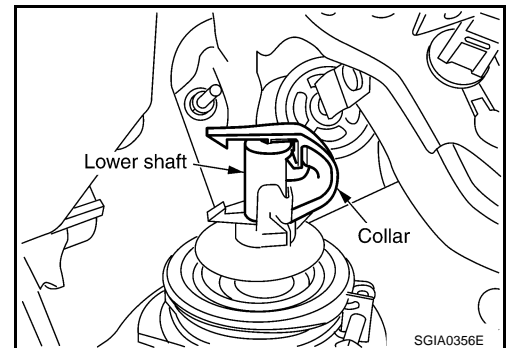

2. Install yoke of column shaft to collar, tack bolt and nut.

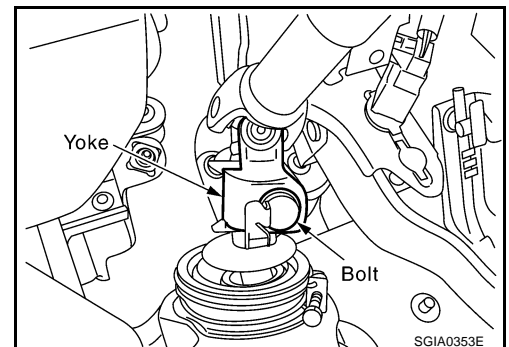

A  
B  
C  
D  
E  
F  
PS  
H  
I  
J  
K  
L  
M

## STEERING COLUMN

- Put steering column assembly (installation hole "P") on bolt for steering member side and install nut "A" then tighten it together with the other bolts at the specified torque.
- Connect yoke and collar with bolt, tighten nut at the specified torque.

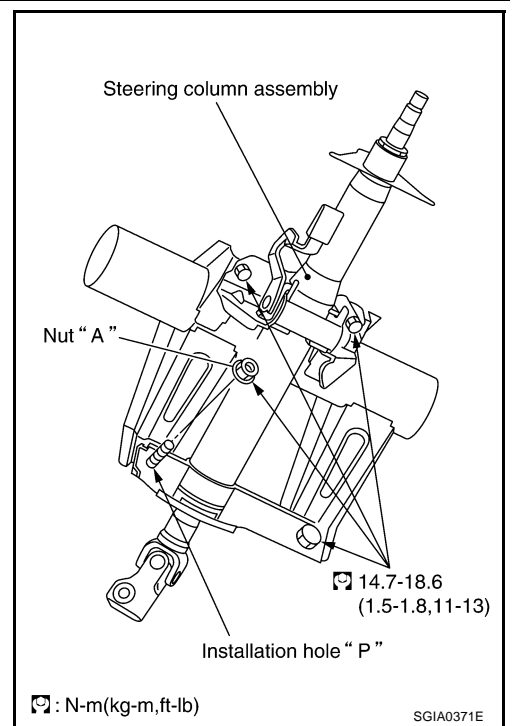

### INSPECTION AFTER INSTALLATION

- After installing steering column to vehicle, check tilt device and its operation range. Ranges of operation are shown in the figure.
- Check if steering operation can turn to the end of the left and right smoothly.

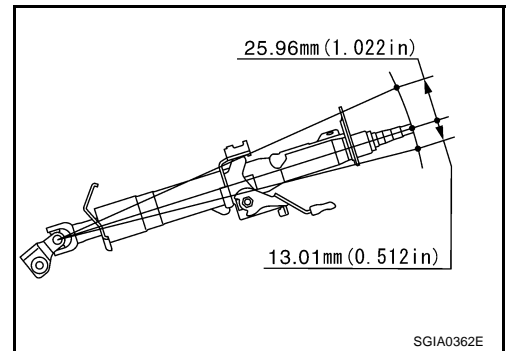

# STEERING COLUMN

## Disassembly and Assembly

AGS00024

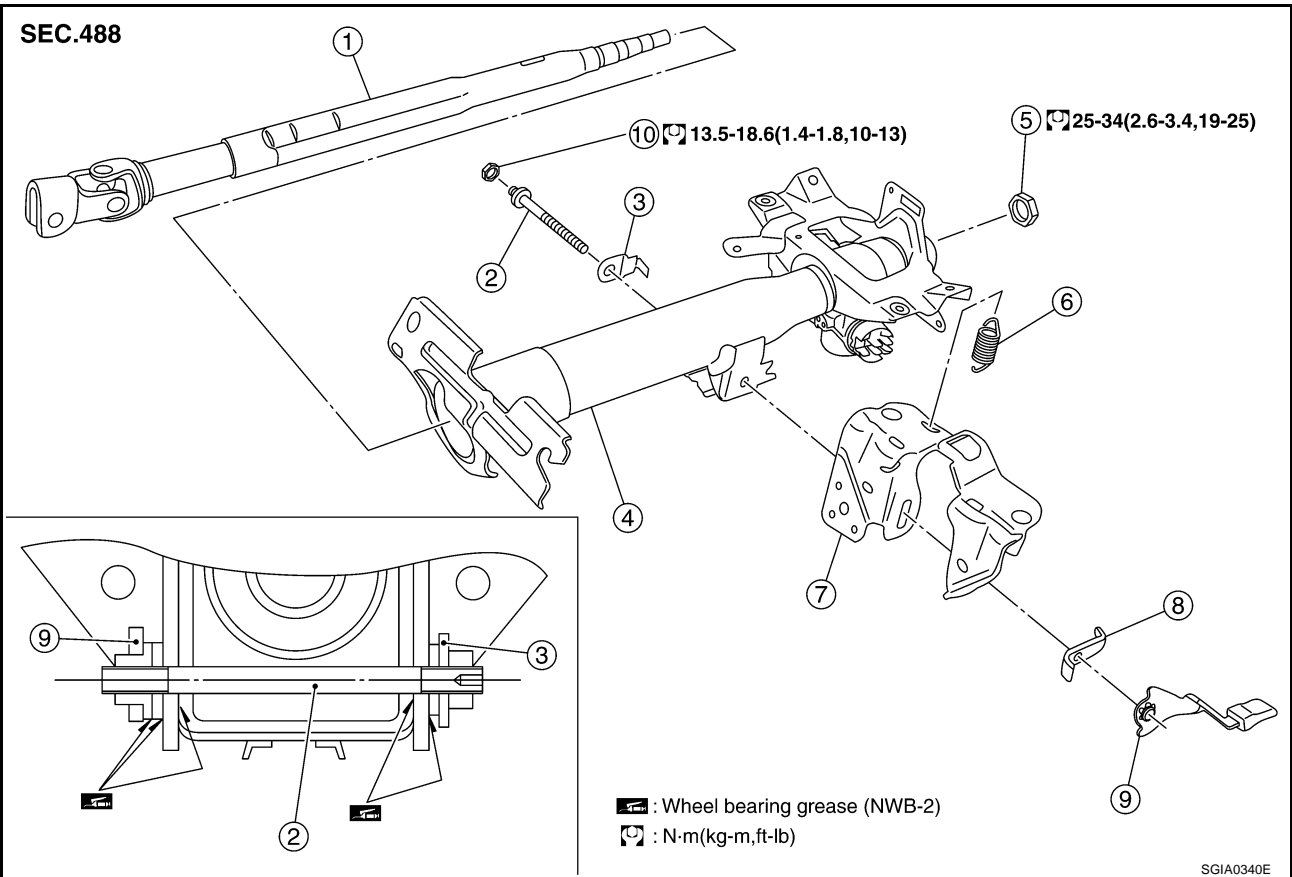

- |                            |                                   |                      |
|----------------------------|-----------------------------------|----------------------|
| 1. Steering column shaft   | 2. Adjusting bolt                 | 3. Adjusting stopper |
| 4. Jacket tube             | 5. Steering column shaft lock nut | 6. Spring            |
| 7. Column mounting bracket | 8. Tilt lever stopper             | 9. Tilt lever        |
| 10. Lock nut               |                                   |                      |

### DISASSEMBLY

1. Remove steering column shaft lock nut, then remove steering column shaft from front side of jacket tube.
2. Remove tilt device from jacket tube.
3. Remove lock nut and adjusting stopper according to the following procedure.
  - a. Turn tilt lever to the unlock side.
  - b. Remove spring from column mounting bracket.

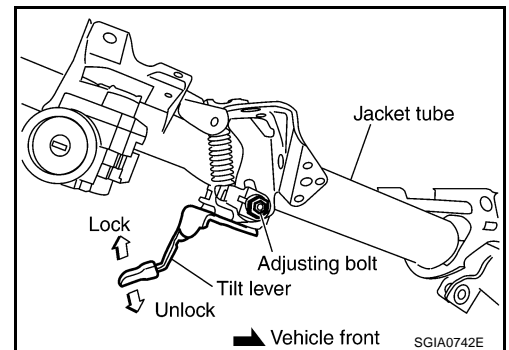

# STEERING COLUMN

- c. Lock adjusting bolt, then remove lock nut.

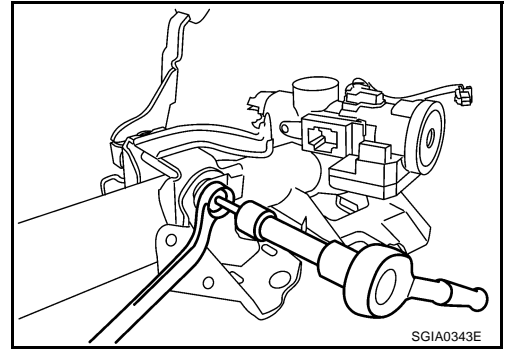

- d. Remove adjusting bolt, adjusting stopper, column mounting bracket, tilt lever stopper and tilt lever from jacket tube.

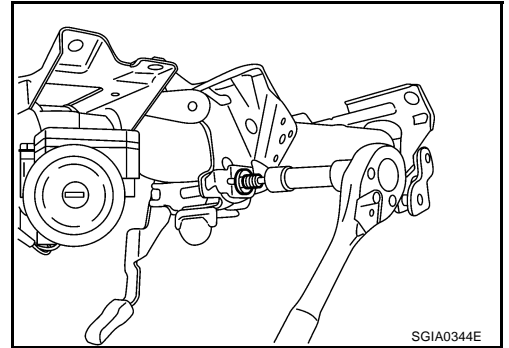

## INSPECTION AFTER REMOVAL

- Check if there is something wrong with the steering column shaft and bearing. And then if they are damaged, replace with new one.
- Check if there is something wrong with the component of the tilt device. And then if it is damaged, replace with new one.

## ASSEMBLY

1. Install tilt device to jacket tube. Refer to [PS-15, "Disassembly and Assembly"](#) .

### NOTE:

- Turn tilt lever to unlock side while at work to make it easier.
- That can avoid column shaft's sudden descent when tilt lever is operated on vehicle.

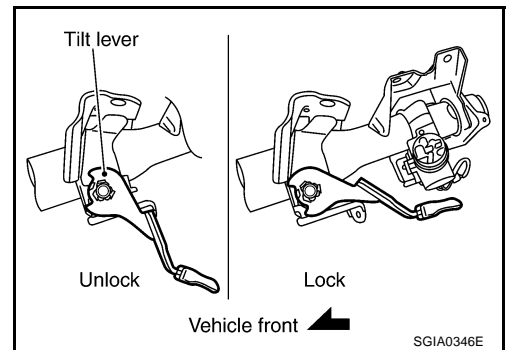

2. When tilt lever is in the locked position (operation range is about 40°), tighten lock nut at the specified torque to make tilt lever locked.

### Tightening torque:

**13.5 - 18.6 N·m (1.4 - 1.8 kg·m, 10 - 13 ft·lb)**

3. Apply grease to the part shown in the figure of component. Refer to [PS-15, "Disassembly and Assembly"](#) .
4. Install steering column shaft to jacket tube, tighten steering column shaft lock nut at the specified torque.

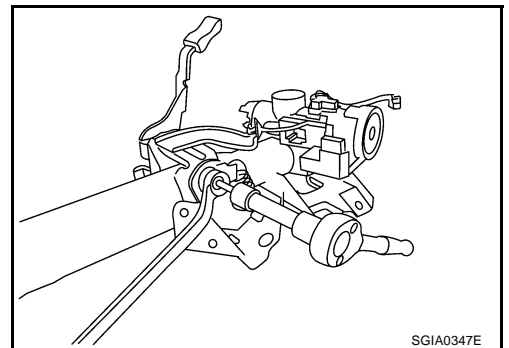

**Tightening torque : 25 - 34 N·m (2.6 - 3.4 kg·m, 19 - 25 ft·lb)**



# POWER STEERING GEAR AND LINKAGE

## POWER STEERING GEAR AND LINKAGE

FFP:49001

### Removal and Installation

AGS00025

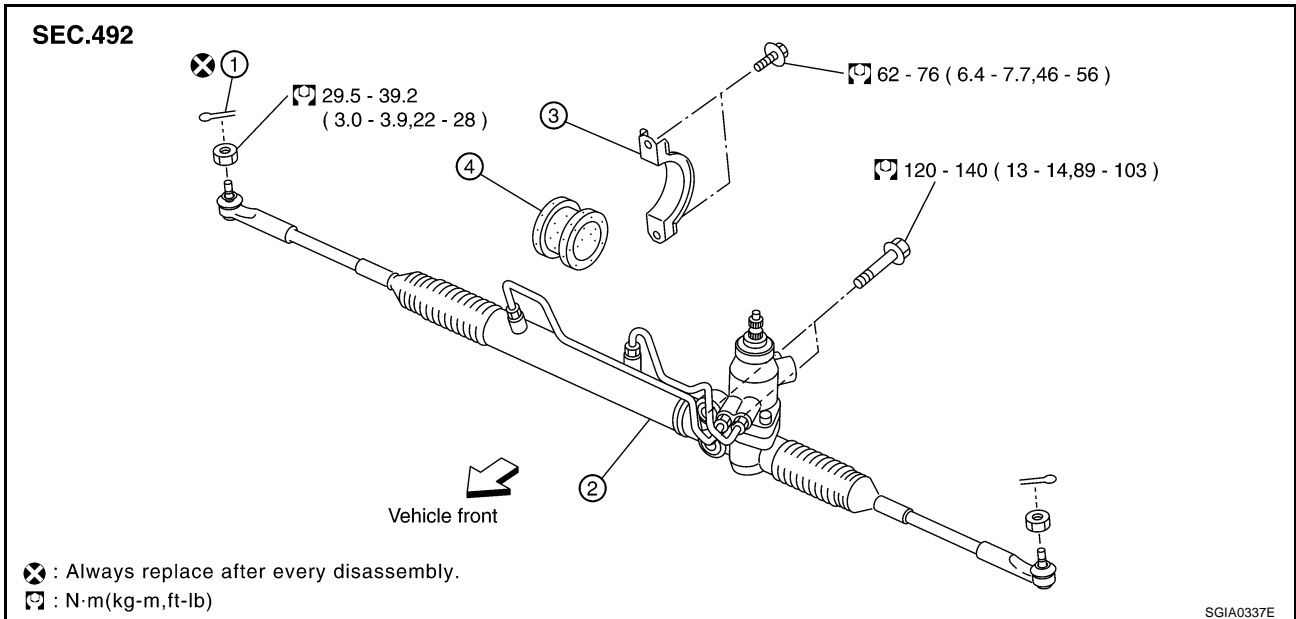

1. Cotter pin
2. Steering gear assembly
3. Rack mounting bracket
4. Rack mounting insulator

### CAUTION:

Spiral cable may snap due to steering operation if steering column is separated from steering gear assembly. Therefore fix steering wheel with a string to avoid turns.

### REMOVAL

1. Set wheels in the straight-ahead position.
2. Remove undercover and tires from vehicle with the power tool.
3. Remove front crossbar. Refer to [FSU-5, "FRONT SUSPENSION ASSEMBLY"](#).
4. Confirm slit of lower joints fits with the projection on rear cover cap, furthermore marking position on steering gear assembly nearly fits with the projection on rear cover cap.
5. Remove cotter pin at steering outer socket, then loosen mounting nut.

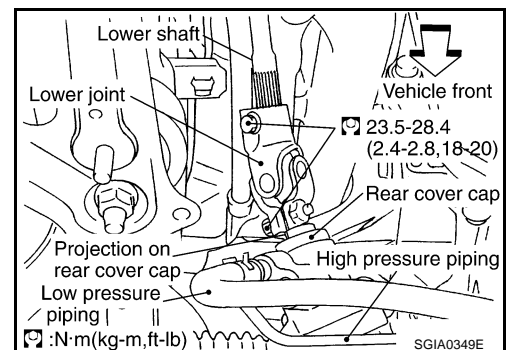

6. Use ball joint remover (SST) to remove steering outer socket from steering knuckle. Be careful not to damage ball joint boot.

### CAUTION:

Tighten temporarily mounting nut to prevent damage to threads and to prevent ball joint remover (SST) from coming off.

7. Remove oil pipings (high pressure side and low pressure side) from steering gear assembly, then drain fluid from pipings.

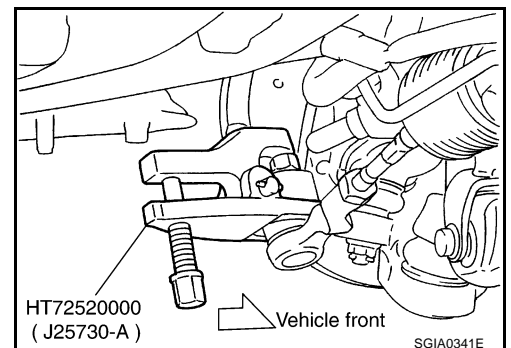

# POWER STEERING GEAR AND LINKAGE

8. Loosen bolt on upper yoke of lower joint and remove bolt on lower yoke of joint, then slide lower joint into lower shaft. Separate steering gear assembly from lower shaft.
9. Tack bolt on upper yoke of lower joint, fix lower joint to lower shaft.

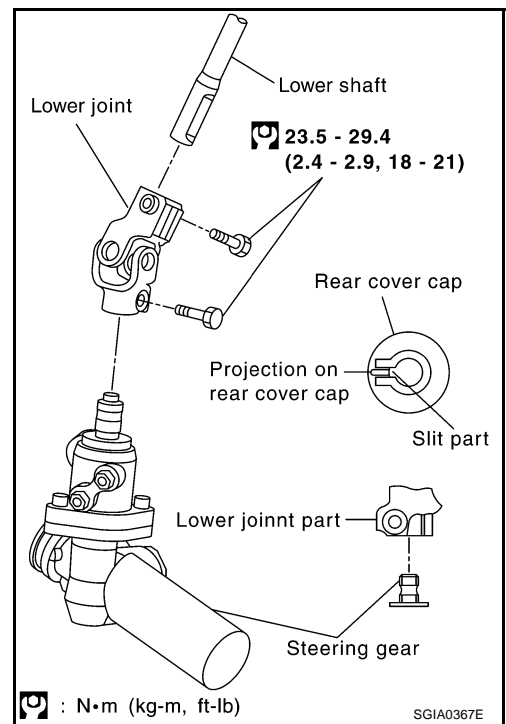

10. Remove the fixing bolt and remove steering gear assembly, rack mounting bracket and insulator from vehicle.

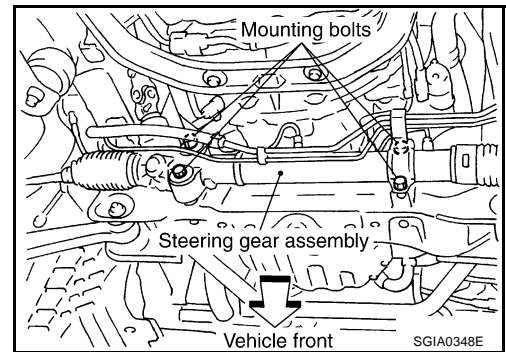

## INSTALLATION

- Refer to [PS-17, "Removal and Installation"](#) for tightening torque. Install in the reverse order of removal.

### NOTE:

Refer to component parts location and to not reuse non-reusable parts.

- After removing/installing or replacing steering components, check wheel alignment. Refer to [FSU-6, "Wheel Alignment Inspection"](#).
- When steering wheel is set in the straight ahead direction, confirm slit of lower joint fits with the projection on rear cover cap, furthermore marking position on steering gear assembly nearly fits with the projection on rear cover cap.
- After installation, bleed air from piping. Refer to [PS-6, "Air Bleeding Hydraulic System"](#).

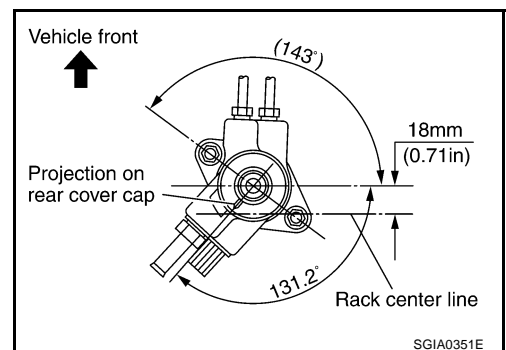

# POWER STEERING GEAR

## POWER STEERING GEAR

PFP:49001

### Component

AGS000AA

A  
B  
C  
D  
E  
F  
PS  
H  
I  
J  
K  
L  
M

SEC.492

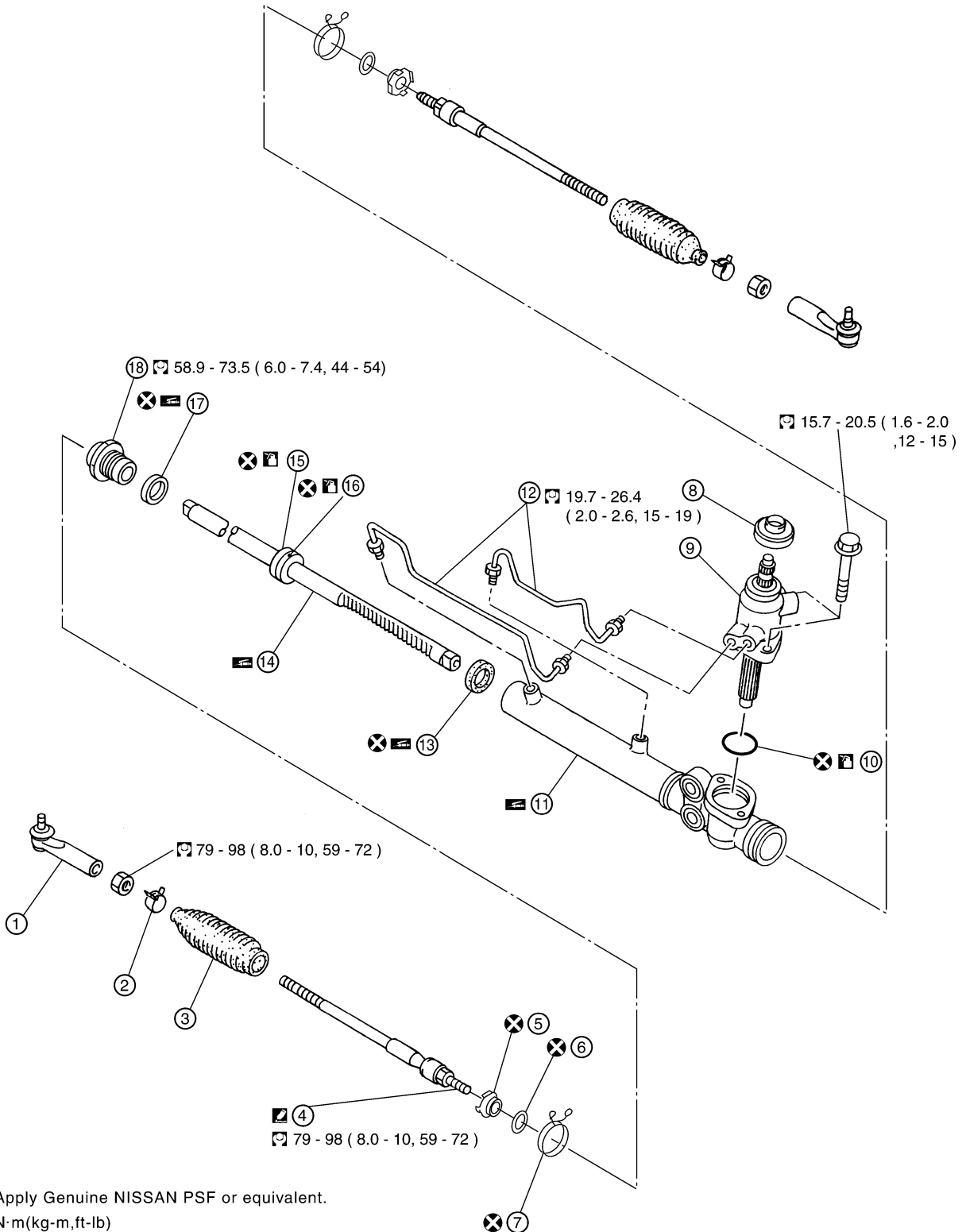

- : Apply Genuine NISSAN PSF or equivalent.
- : N·m(kg-m,ft-lb)
- : Three Bond TB1111B
- : Multi-purpose grease or equivalent.
- : Always replace after every disassembly.

SGIA0743E

# POWER STEERING GEAR

- |                   |                           |                        |
|-------------------|---------------------------|------------------------|
| 1. Outer socket   | 2. Boot clamp             | 3. Boot                |
| 4. Inner socket   | 5. Lock plate             | 6. Spacer ring         |
| 7. Boot clamp     | 8. Rear cover cap         | 9. Gear sub assembly   |
| 10. O-ring        | 11. Gear housing assembly | 12. Cylinder tubes     |
| 13. Rack oil seal | 14. Rack                  | 15. Rack Teflon ring   |
| 16. O-ring        | 17. Rack oil seal         | 18. End cover assembly |

## CAUTION:

- Secure steering gear assembly with a vise, using copper plates or something similar to prevent it from being damaged. Do not grip cylinder with a vise.
- Before performing disassembly, clean steering gear assembly with kerosene. Be careful not to bring any kerosene into contact with the discharge and return port connectors.

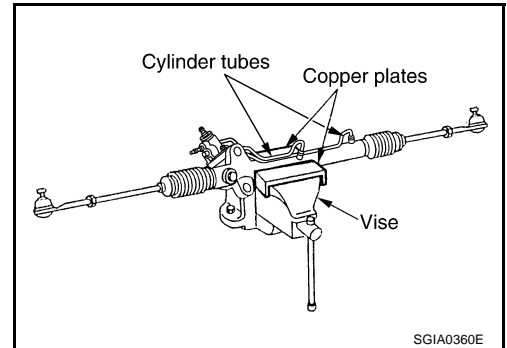

## Disassembly and Assembly

### DISASSEMBLY

1. Remove cylinder tubes from gear housing assembly.
2. Remove rear cover cap from gear sub-assembly.
3. Measure adjusting screw height from gear housing assembly, then loosen adjusting screw.

## CAUTION:

- Do not turn adjusting screw more than twice.
  - Replace steering gear assembly when adjusting screw is removed or more than twice.
4. Remove fixing bolt of gear sub-assembly and remove gear sub-assembly from gear housing assembly.

## CAUTION:

In order to protect oil seal from any damage, pull sub-gear assembly out straightly.

5. Loosen lock nut of outer socket, and remove outer socket.
6. Remove boot clamps of the small diameter side and the large diameter side, then remove boots.

## CAUTION:

On removing boots, be careful not to damage inner socket and gear housing assembly. If they are is damaged, change them to avoid oil leaks.

7. Move spacer ring to rack side, raise caulking part (at two points of part A) of lock plate and loosen inner socket, then remove inner socket from rack.

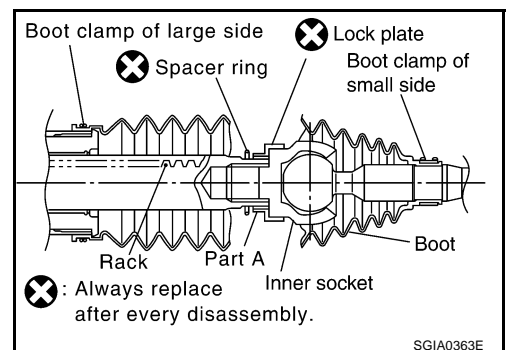
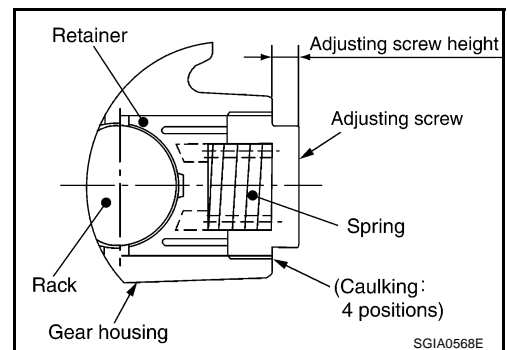

# POWER STEERING GEAR

8. Drill out the clinching part of cylinder outer rim with a 3 mm (0.12 in) drill in 1.5 mm (0.059 in) depth.

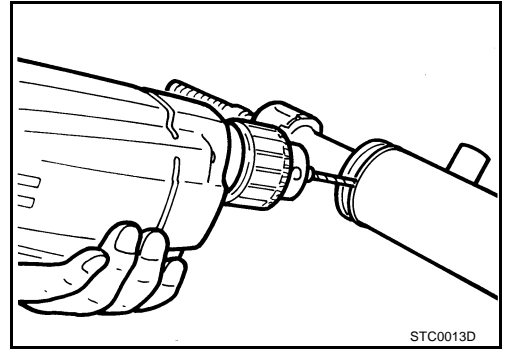

9. Remove end cover assembly with a 42 mm (1.65 in) open head (suitable tool).

**CAUTION:**

**Be careful not to damage rack. If it is damaged, replace rack. Otherwise, oil leaks may result.**

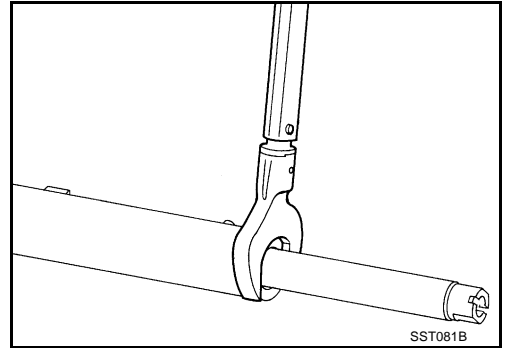

10. Pull rack with rack oil seal out of gear housing assembly.

**CAUTION:**

**Be careful not to damage cylinder. If it is damaged, replace gear housing assembly. Otherwise, oil leaks may result.**

11. Heat rack Teflon ring to approximately 40°C (104°F) with a dryer, then remove it and O-ring from rack.

**CAUTION:**

**Be careful not to damage rack. If it is damaged, change to a new one to avoid oil leaks.**

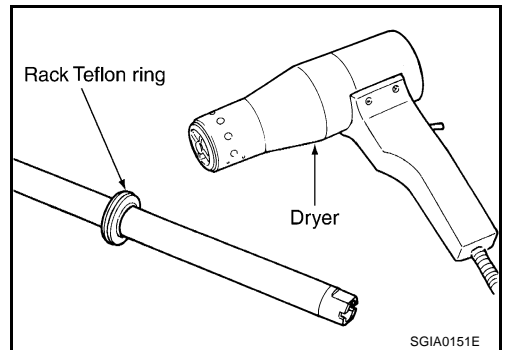

12. Use a taped 29 mm (1.14 in) socket and an extension bar. Remove rack oil seal from gear housing assembly.

**CAUTION:**

**Be careful not to damage gear housing assembly and cylinder inner wall. If it is damaged, gear housing assembly must be replaced. Otherwise, oil leaks will result.**

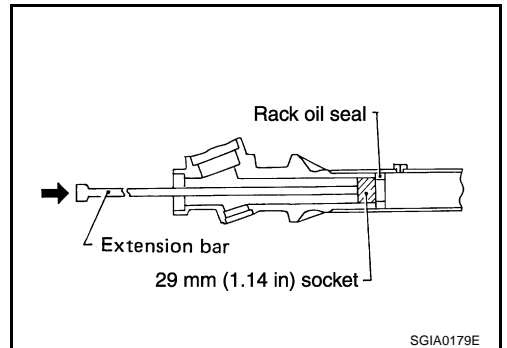

A  
B  
C  
D  
E  
F

PS

H  
I  
J  
K  
L  
M

# POWER STEERING GEAR

## INSPECTION AFTER DISASSEMBLY

### Boot

Check boot for cracks and deformation. Replace it, if necessary.

### Rack

Check rack for damage and wear. Replace it, if necessary.

### Gear Sub-Assembly

- Check pinion gear for damage and wear. Replace it, if necessary.
- Check bearing while rotating it. Replace bearing if bearing ball race was dent, worn, or damaged.

### Gear Housing Assembly

Check gear housing assembly for damage and scratches (inner wall). Replace it, if necessary.

### Outer Socket and Inner Socket

#### Swing Torque

- Hook a spring balance at the point shown in the figure. Confirm if the reading is within the specification. When ball stud and inner socket start moving the measured value must be within the specification. If the reading is outside the specification, replace socket.

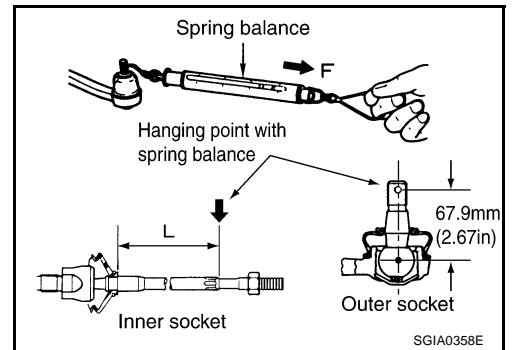

#### Specified value

Item	Outer socket	Inner socket
Measuring point	Cotter-pin hole of stud	shown as L: 48.5 mm (1.91 in)
Swing torque	0.30 - 2.90 N·m (0.03 - 0.29 kg·m, 3 - 25 in·lb)	1.0 - 7.8 N·m (0.10 - 0.80 kg·m, 9 - 69 in·lb)
Measuring value	4.42 - 42.7 N (0.45 - 4.4 kg, 1.0 - 9.7 lb)	10 - 78 N (1.1 - 7.9 kg, 2.25 - 17.5 lb)

#### Rotating Torque

- Using a preload gauge (SST), check if reading is within the value specified below. If the value is outside the standard, replace outer sockets.

Rotating torque	0.30 - 2.90 N·m (0.03 - 0.29 kg·m, 3 - 25 in·lb)
-----------------	--

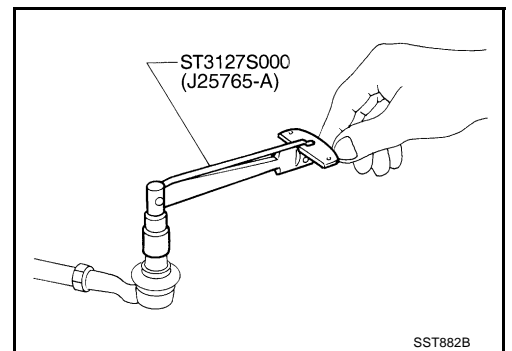

# POWER STEERING GEAR

## Axial End Play

- Apply load of 490 N (50 kg, 110 lb) to ball stud axially. Use a dial-gauge to measure the amount of the movement that the stud makes. Check if the reading is within the specified below. If the value is outside the standard, replace outer and inner sockets.

Outer socket	0.5 mm (0.020 in) or less
Inner socket	0.2 mm (0.008 in) or less

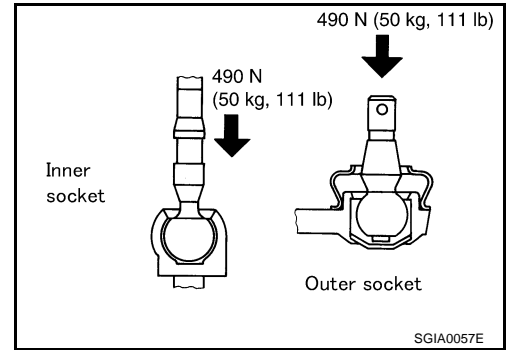

## ASSEMBLY

- Apply Genuine NISSAN PSF or equivalent to O-ring. Put an O-ring into rack Teflon ring.

### NOTE:

Do not reuse O-ring.

- Heat rack Teflon ring to approximately 40°C (104°F) with a dryer. Assemble it to mounting groove of rack.

### NOTE:

Do not reuse rack Teflon ring.

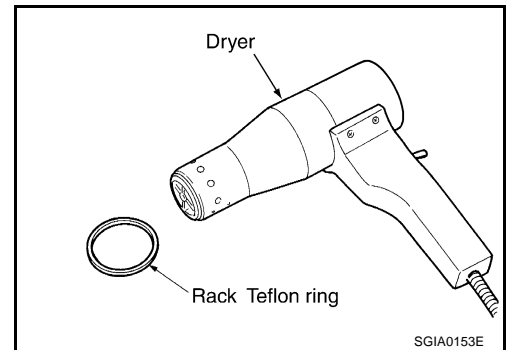

- To fit rack Teflon ring on rack, use rack Teflon ring installation tool (SST) from tooth side. Compress rim of ring with the tool.

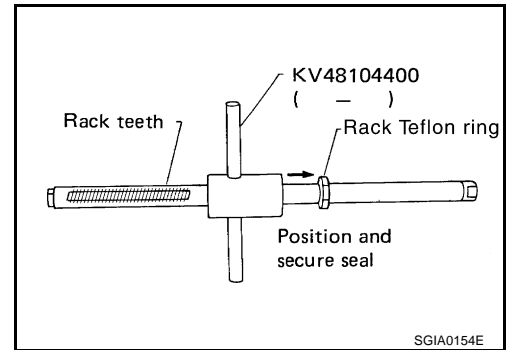

- Apply Multi-purpose grease or equivalent to rack oil seal. Insert rack oil seal, then insert rack to gear housing assembly.

### NOTE:

Do not reuse rack oil seal.

### CAUTION:

- When inserting rack, do not damage retainer sliding part. If it is damaged, replace gear housing assembly.
- When unstringing rack, do not damage cylinder inner wall. If it is damaged, it may cause oil leaks. Replace gear housing assembly.

# POWER STEERING GEAR

- Attach rack oil seal. Both inner lip and outer lip should face each other.

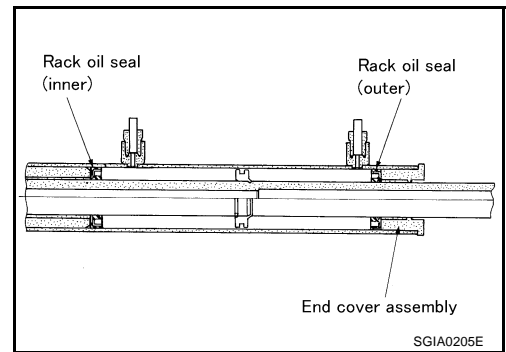

- To avoid damaging inner rack oil seal, wrap an OHP sheet [approximately. 70 mm (2.76 in) × 100 mm (3.94 in)] around rack tooth. Place oil seal on sheet. Then, pull oil seal along with OHP sheet until they pass the toothed section of rack, then remove it.

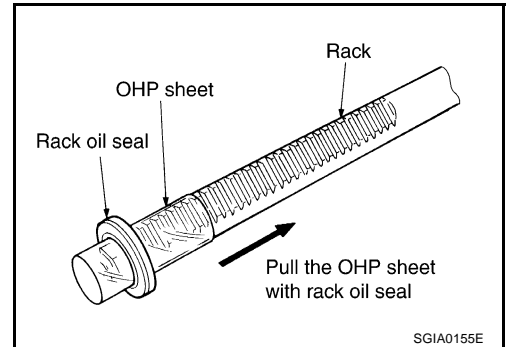

- Insert rack oil seal (inner) to piston (rack Teflon ring) position and push retainer to adjust screw side with fingers lightly, and then make rack move in gear housing assembly, install rack oil seal (inner) to fit in with gear housing assembly.

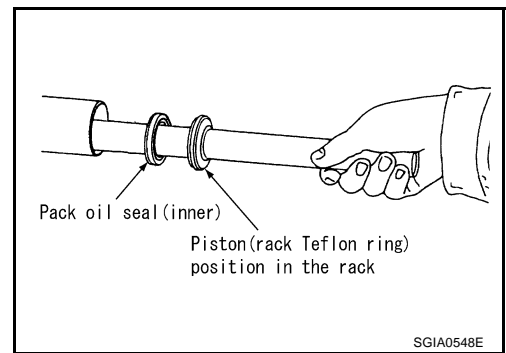

- When installing outer rack oil seal, cover the end of rack with an OHP sheet [70 mm (2.76 in) × 100 mm (3.94 in)]. It will avoid damaging rack oil seal. Then place oil seal on sheet. Pull rack oil seal along with OHP sheet until they pass rack end. Then remove OHP sheet.

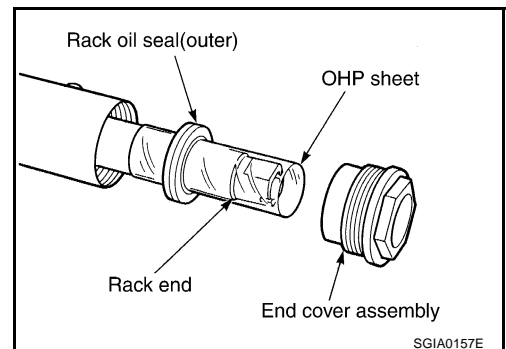

- Install end cover assembly to rack, move it to gear housing assembly.

- Using a 42 mm (1.65 in) open head (suitable tool), tighten end cover assembly at the specified torque.

**CAUTION:**

**Do not damage rack surface. If it is damaged, it may cause oil leaks. Replace rack assembly.**

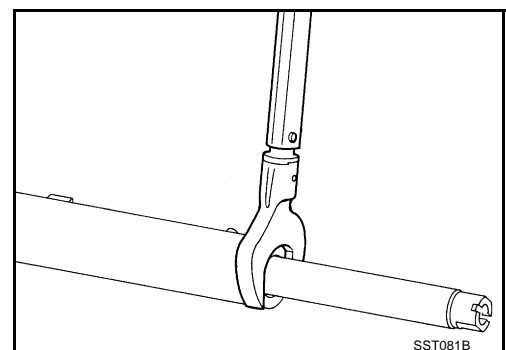



# POWER STEERING GEAR

6. After tightening end cover assembly, caulk cylinder at one point as shown in the figure using a punch. This will prevent end cover from getting loose.
7. Apply Genuine NISSAN PSF or equivalent to O-ring. Install O-ring to gear housing assembly.

**NOTE:**

Do not reuse O-ring.

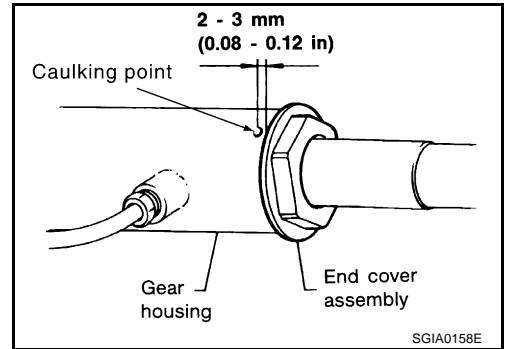

8. Install gear sub-assembly to gear housing assembly.

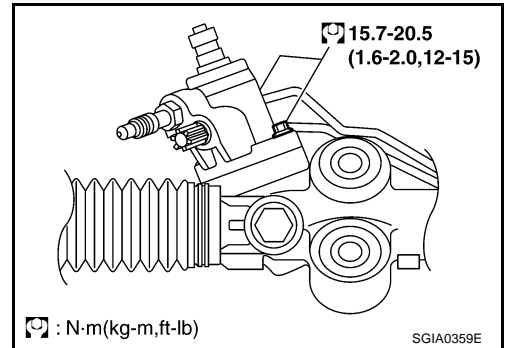

9. Attach lock plate to rack.

**NOTE:**

Do not reuse lock plate.

- a. Tack spacer ring to rack.

**NOTE:**

Do not reuse spacer ring.

- b. Install lock plate to inner socket.
- c. Apply thread lock adhesive (Three Bond 1324 or equivalent) to the thread of inner socket. Screw inner socket into the rack and tighten at the specified torque.
- d. Caulk lock plate at two points on rack slit.
- e. Install spacer ring to lock plate as shown in the figure.

**CAUTION:**

When installing spacer ring, avoid damaging it.

10. Decide neutral position of rack gear.

**Rack stroke "L" : 64.5 mm (2.54 in)**

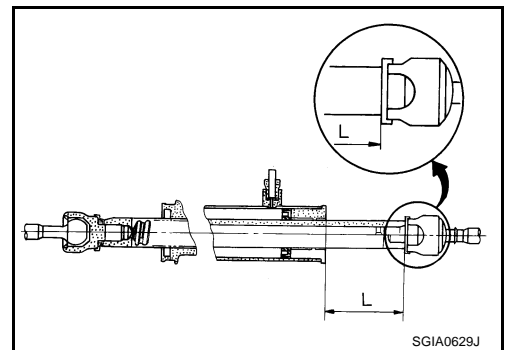
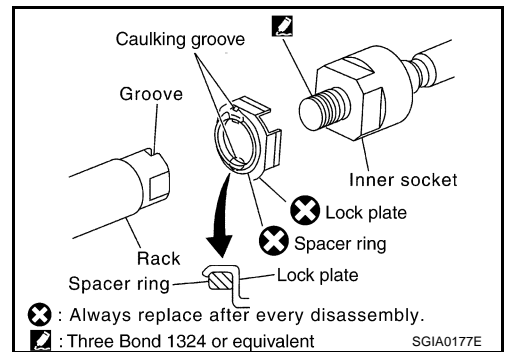

A  
B  
C  
D  
E  
F  
PS  
H  
I  
J  
K  
L  
M

# POWER STEERING GEAR

11. Install the projection part (Tip) of rear cover cap to gear sub-assembly as shown in the figure.

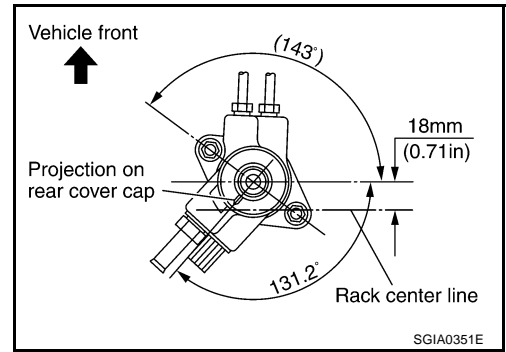

12. Apply thread locking adhesive (Three Bond TB1111B or equivalent) to the thread of adjusting screw to the adjusting screw height from gear housing assembly. The adjusting screw height is the same as it was measured in the overhaul in advance.
13. Rotate pinion ten times whole range of rack so that parts get to fit with each other.

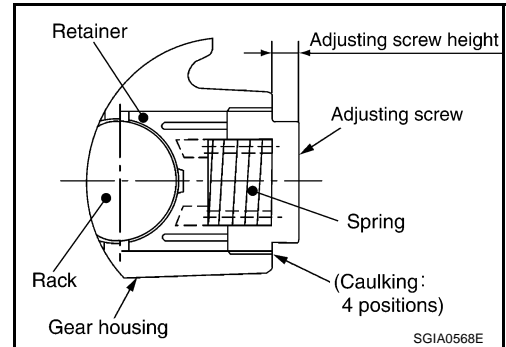

14. Measure pinion rotating torque within from  $-180^\circ$  to  $+180^\circ$  make preload gauge (SST) and torque adapter (SST) in rack neutral position, then hold preload gauge (SST) at maximum torque.
15. After loosening adjusting screw once, tighten it again with torque of 4.9 - 5.9 N·m (0.50 - 0.60 kg·m, 44 - 52 in·lb). After that loosen it within from  $20^\circ$  to  $40^\circ$ .

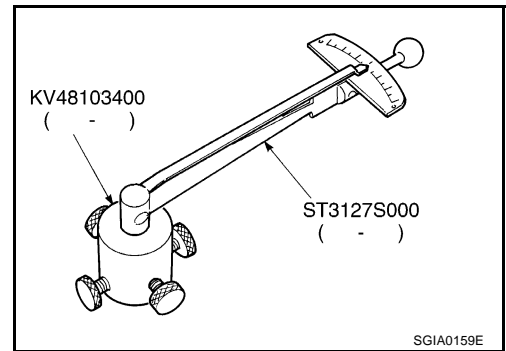

16. Measure pinion rotating torque with torque adapter (SST) and preload gauge (SST), then confirm whether its reading is within the specified value. If the reading is not within the specified value, readjust screw angle with adjusting screw. Change gear assembly to new one, if the reading is still not within the specified value or the rotating torque of adjusting screw is less than 5 N·m (0.51kg·m, 44 in·lb)

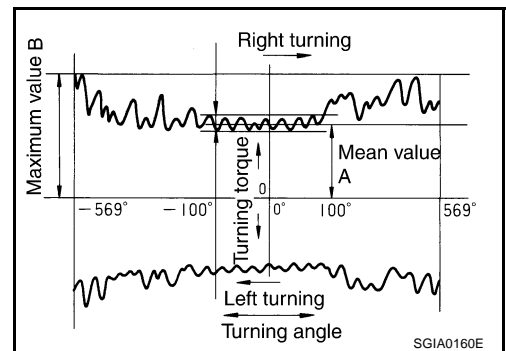

## Pinion rotation torque:

**Around neutral position (within  $\pm 100^\circ$ )**

**Average "A":**

**0.8 - 2.0 N·m (0.09 - 0.20 kg·m, 7 - 17 in·lb)**

**Other than above (more than  $\pm 100^\circ$ )**

**Maximum variation "B":**

**2.3 N·m (0.23 kg·m, 20 in·lb)**

17. Turn pinion fully to the end of the left with tie-rods to rack.

# POWER STEERING GEAR

18. Set dial gauge to rack as shown in the figure. Measure vertical movement of rack when pinion is turned counterclockwise with torque of 19.6 N-m (2.0 kg-m, 14 ft-lb). Check reading is within the specified value. If reading is outside of the specification, readjust screw angle with adjusting screw. If reading is still outside of specification, or if the rotating torque of adjusting screw is less than 5 N-m (0.51 kg-m, 44 in-lb), replace steering gear assembly.

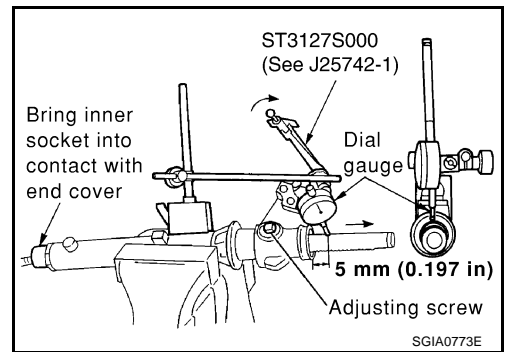

## Specified value

Amount of vertical movement with rack	Less than 0.265 mm (0.010 in)	
measuring point	Axial direction of rack	5 mm (0.197 in) away from end of gear housing
	Radius direction of rack	Shaft direction of adjusting screw

19. Install large-diameter side of boot to gear housing assembly.  
 20. Install small-diameter side of boot to the mounting groove of inner socket boot.  
 21. Install boot clamp to the small-diameter side of boot.  
 22. Install boot clamp to the large-diameter side of boot.

### NOTE:

Do not reuse boot clamp.

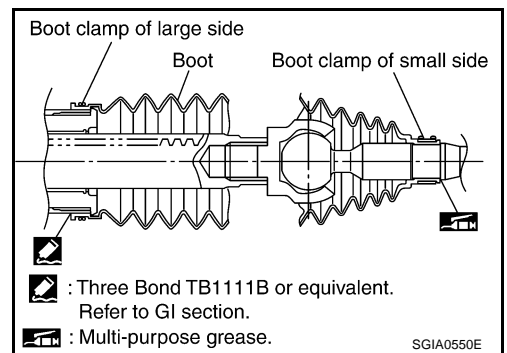

- a. Tighten large-diameter side of RH/LH boot with boot clamp (stainless wire).

**Wire length "L" : 370 mm (14.567 in)**

- b. After wrapping clamp around boot groove for two turns, insert screwdriver in loop on both ends of wire. Twist 4 to 4.5 turns while pulling with a force of approx. 98 N (10 kg, 22.1 lb).

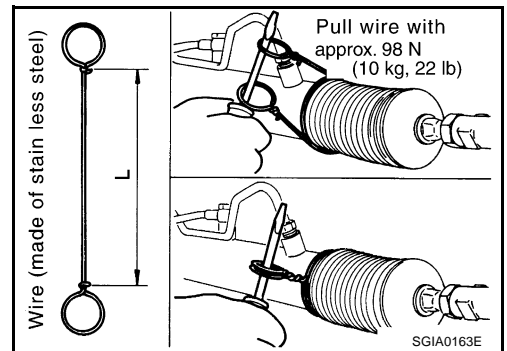

- c. Twist boot clamp as shown in the figure, pay attention to relationship between winding and twisting directions.

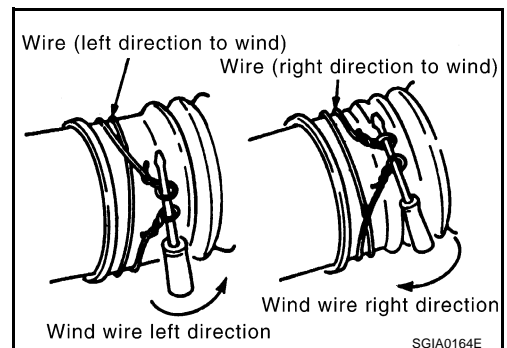

# POWER STEERING GEAR

- d. Confirm the twisted point with clamp faces in the opposite direction to adjusting screw within  $30^\circ$  as shown in the figure.

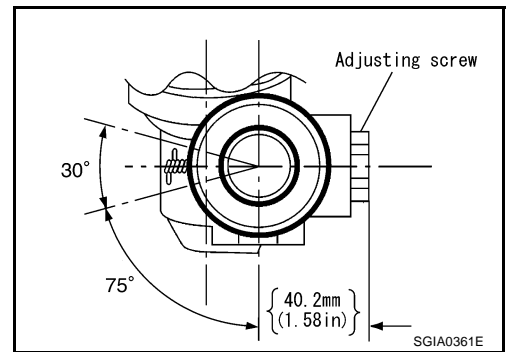

- e. After twisting wire 4 to 4.5 turns, bend cut end of wire. Cut end of wire should not touch boot. Be sure wire end is at least 5 mm (0.20 in) away from clearance for tube.

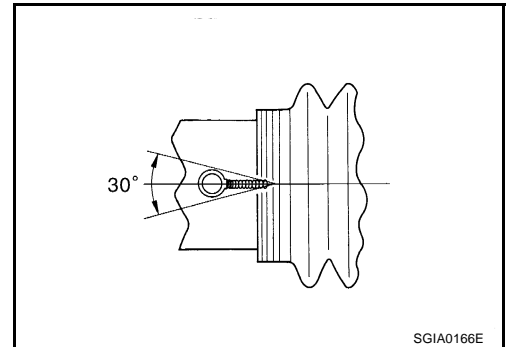

23. Install cylinder tubes to gear housing assembly.

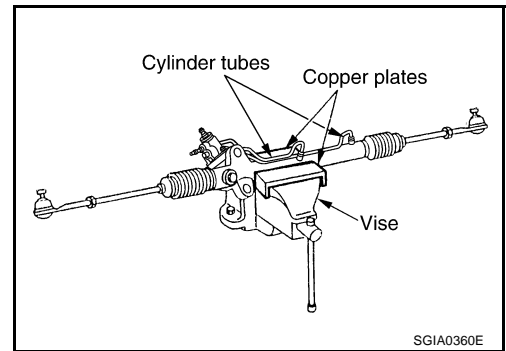

24. Tighten lightly tie-rod in specified length "L", then tighten lock nut at specified torque. Refer to [PS-20, "Disassembly and Assembly"](#). Reconfirm if tie-rod length is within limit of specified length "L".

**Inner socket length "L" : 107.7 mm (4.240 in)**

**CAUTION:**

Perform toe-in adjustment after this procedure. Length achieved after toe-in adjustment is not necessarily value given here.

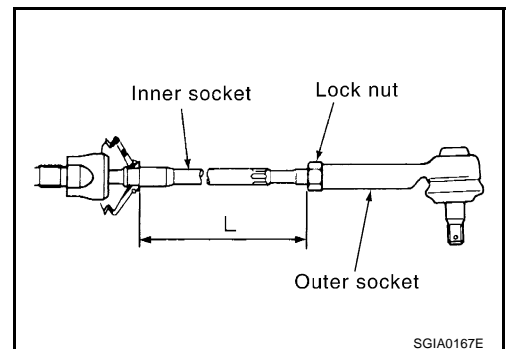

# POWER STEERING OIL PUMP

## POWER STEERING OIL PUMP

PF:49110

### On-Vehicle Service CHECKING RELIEF OIL PRESSURE

AGS00028

#### CAUTION:

Before starting work, confirm belt tension is proper.

1. Connect oil pressure gauge (SST) and oil pressure gauge adapter (SST) between oil pump discharge connector and high pressure hose and then bleed air from the hydraulic circuit.

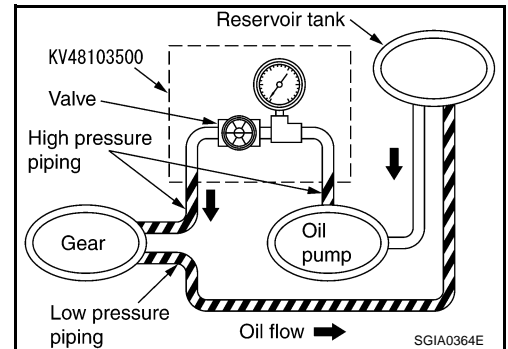

2. Start engine. Allow engine to run until tank temperature reaches 50 to 80°C (122 to 176°F).

#### CAUTION:

- Warm up engine with shut-off valve fully opened. If engine is started with shut-off valve closed, fluid pressure in power steering pump increases to maximum. This will raise fluid temperature excessively.
- Be careful not to contact hose with belt when engine is started.

3. With engine at idle, close shut-off valve and read the relief oil pressure.

#### Relief oil pressure

9,600 - 10,200 kPa (98 - 104 kg/cm<sup>2</sup> , 1,390 - 1,480 psi)

#### CAUTION:

Do not close shut-off valve of pressure gauge for more than 10 seconds.

4. After measurement, open shut-off valve slowly.
  - If relief oil pressure is outside the specification, disassemble and repair oil pump. Refer to [PS-30, "Disassembly and Assembly"](#) .
5. After inspection, disconnect oil pressure gauge (SST) and oil pressure gauge adapter (SST) from hydraulic circuit, connect oil pump discharge connector and high pressure hose. Add fluid and bleed air from hydraulic circuit thoroughly. Refer to [PS-6, "Air Bleeding Hydraulic System"](#) .

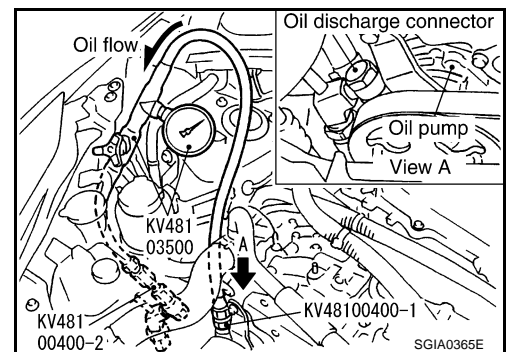

## Removal and Installation

### REMOVAL

AGS00029

1. Remove engine cover.
2. Remove air cleaner box.
3. Drain water from radiator upper tank, then remove radiator upper hose.
4. Remove radiator fan shroud. Refer to [CO-11, "Removal and Installation"](#) .
5. Loosen idler pulley, then remove belt.
6. Drain power steering fluid from reservoir tank.
7. Remove piping of high pressure and low pressure (drain fluid from their pipings)
8. Remove bolt common to water pump and power steering pump.
9. Remove bolt then remove power steering pump.

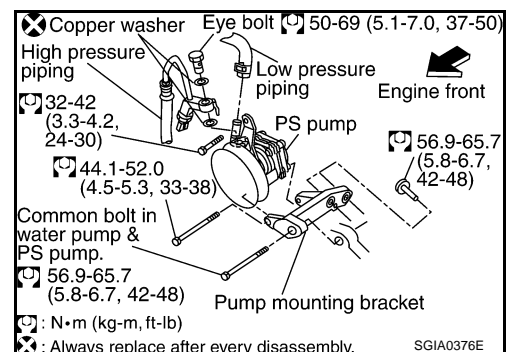

# POWER STEERING OIL PUMP

## INSTALLATION

Refer to [PS-34, "HYDRAULIC LINE"](#) for tightening torque. Install in the reverse order of removal.

- After installation, adjust belt tension. Refer to [EM-13, "DRIVE BELTS"](#).
- After installation, bleed air. Refer to [PS-6, "Air Bleeding Hydraulic System"](#).

## Disassembly and Assembly

AGS0002A

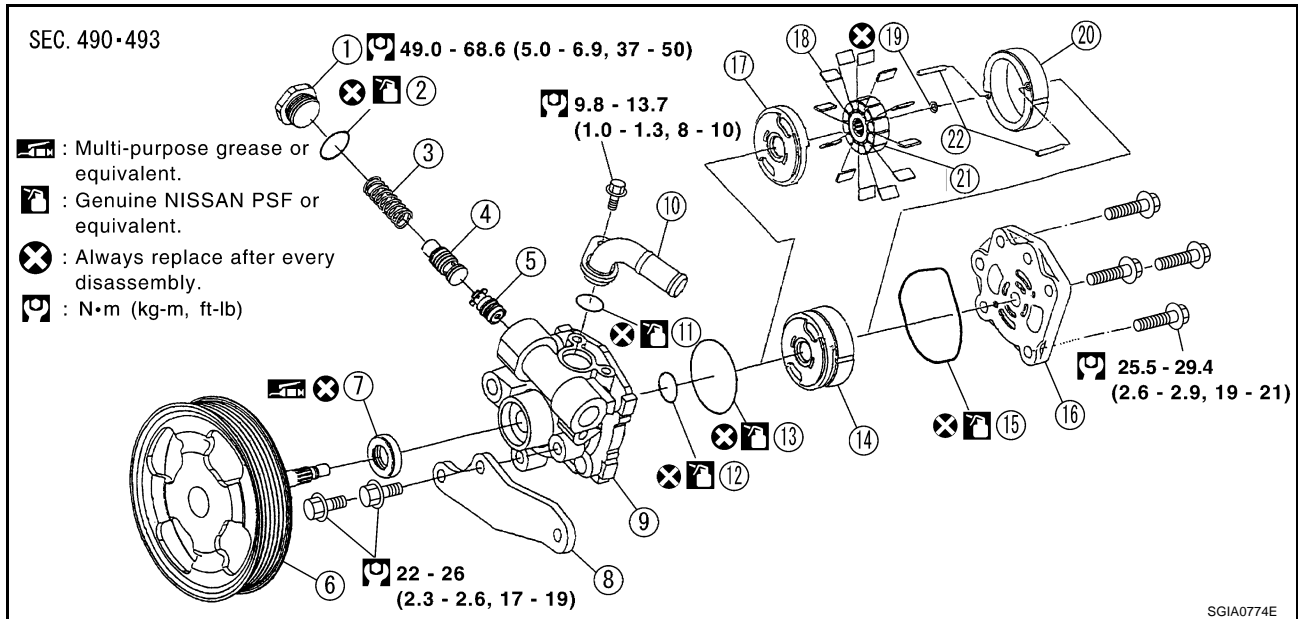

- |                                |                                |                              |
|--------------------------------|--------------------------------|------------------------------|
| 1. Plug                        | 2. O-ring D                    | 3. Flow control valve spring |
| 4. Relief valve assembly       | 5. Flow control valve assembly | 6. Shaft kit                 |
| 7. Oil seal                    | 8. Bracket                     | 9. Body assembly             |
| 10. Suction connector assembly | 11. O-ring E                   | 12. O-ring C                 |
| 13. O-ring B                   | 14. Cartridge assembly         | 15. O-ring A                 |
| 16. Cover assembly             | 17. Side plate                 | 18. Vane                     |
| 19. Rotor snap ring            | 20. Cam ring                   | 21. Rotor                    |
| 22. Dowel pin                  |                                |                              |

## INSPECTION AFTER DISASSEMBLY

Disassemble power steering oil pump only if the following items are found.

- Oil leakage from oil pump
- Deformed or damaged pulley
- Poor performance

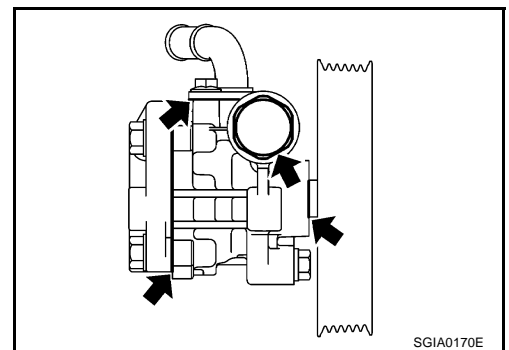

## DISASSEMBLY

### NOTE:

Fix oil pump in vise as the occasion demands.

### CAUTION:

**When retaining drive shaft in a vise, always use copper or aluminium plates between vise and shaft.**

1. Unscrew two front bracket bolts and remove bracket from body assembly.
2. Unscrew four cover assembly bolts and remove cover assembly from body assembly.
3. Remove O-ring A from body assembly.

# POWER STEERING OIL PUMP

4. Remove rotor snap ring with snap ring pliers, and remove shaft kit from body assembly.

**CAUTION:**

**When removing rotor snap ring, be careful not to damage pulley shaft of shaft kit.**

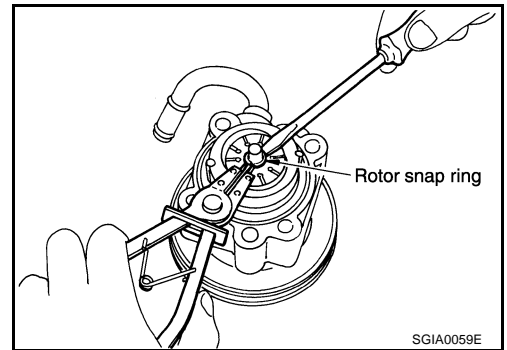

5. Using a screwdriver, remove oil seal for body assembly.
6. Remove cam ring, rotor, vane, side plate, O-ring B and O-ring C from body assembly.
7. Remove plug, then remove O-ring D, flow control valve spring, relief valve assembly and flow control valve assembly from body assembly.

**CAUTION:**

**Be careful not to drop and deform relief valve assembly and flow control valve assembly.**

8. Remove fixing bolt of suction connector assembly, then remove suction connector assembly and O-ring E from body assembly.

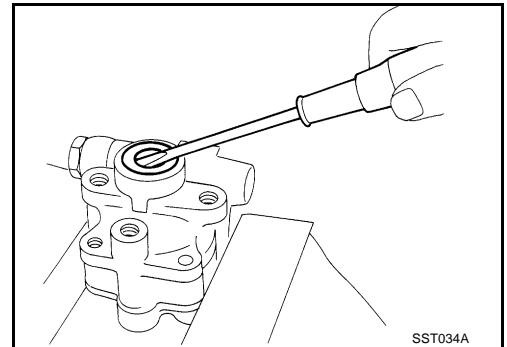

## INSPECTION AFTER DISASSEMBLY

### Body Assembly and Cover Assembly Inspection

- Check body assembly and cover assembly for damage. If any damage is found, replace with new part for cover assembly, and replace with new power steering pump assembly for body assembly.

### Cartridge Assembly Inspection

- Check cam ring, side plate, rotor and vane for damage. If any damage is found, replace cartridge assembly with new one.

### Relief Valve Assembly Inspection

- Check relief valve assembly for damage. If any damage is found, replace it with new one.

### Flow Control Valve Assembly Inspection

- Check flow control valve assembly for damage. If any damage is found, replace it with new one.

## ASSEMBLY

**NOTE:**

Fix oil pump in vise as occasion demands.

**CAUTION:**

**When retaining drive shaft in a vise, always use copper or aluminum plates between vise and shaft.**

1. Apply a coat of Multi-purpose grease or equivalent to oil seal lip and to the circumference of oil seal. Using proper tool such as hand press machine, install it to body assembly.

**NOTE:**

Do not reuse oil seal.

2. Install shaft kit to body assembly.
3. Apply a coat of NISSAN PSF or equivalent to O-ring B and O-ring C, then install O-ring B and O-ring C to body assembly.

**NOTE:**

Do not reuse O-ring B and O-ring C.

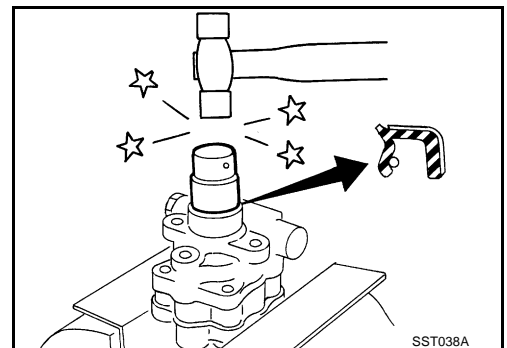

A  
B  
C  
D  
E  
F  
PS  
H  
I  
J  
K  
L  
M

# POWER STEERING OIL PUMP

4. Set dowel pin at the illustration position (The position is the same regardless of right or left direction), and install side plate to body assembly.

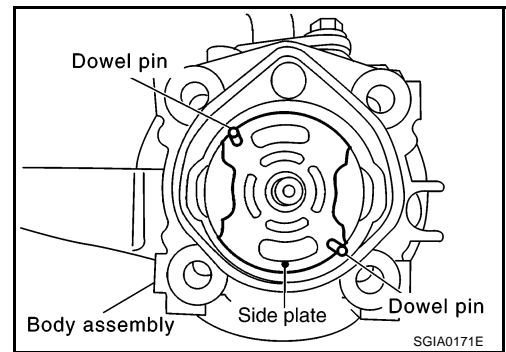

5. Install cam ring on side plate as follows;
- Turn chamfered edge side of cam ring to side plate as shown in the figure.
  - Position large chamfered side of cam ring as shown in the figure.

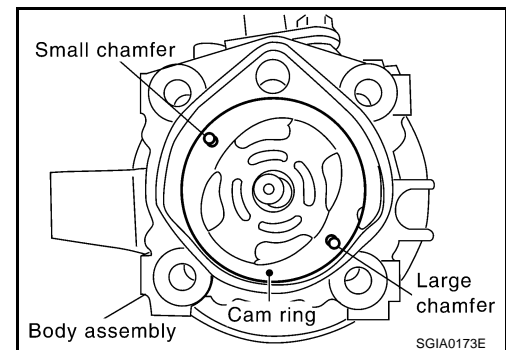
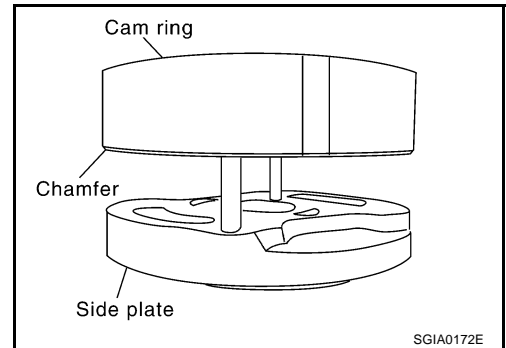

6. Install rotor to shaft of shaft kit (rotor direction is the same regardless of the front and back).
7. Install vane to rotor (vane direction is the same regardless of inside and outside).
8. Install rotor snap ring to shaft of shaft kit.

**NOTE:**

- Do not reuse rotor snap ring.

**CAUTION:**

**Be careful not to damage rotor and pulley shaft.**

9. Apply a coat of NISSAN PSF or equivalent to O-ring A, then install O-ring A to body assembly.

**NOTE:**

Do not reuse O-ring A.

10. Attach cover assembly to body assembly and tighten fixing bolts diagonally at the specified torque.
11. Install flow control valve assembly, relief valve assembly and flow control valve spring to body assembly.
12. Apply a coat of NISSAN PSF or equivalent to O-ring D and install to plug, then tighten plug at the specified torque.

**NOTE:**

Do not reuse O-ring D.

13. Apply a coat of NISSAN PSF or equivalent to O-ring E and install to suction connector assembly, then install suction connector to body assembly.

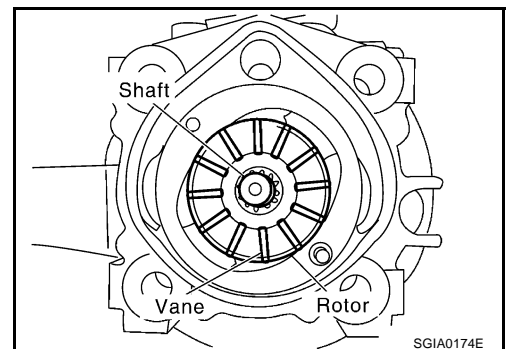



# POWER STEERING OIL PUMP

---

**NOTE:**

Do not reuse O-ring E.

14. Install bracket to body assembly, and tighten mounting bolts at the specified torque.

A

B

C

D

E

F

**PS**

H

I

J

K

L

M



# HYDRAULIC LINE

---

- |                            |                           |                            |
|----------------------------|---------------------------|----------------------------|
| 1. Reservoir tank          | 2. Reservoir tank bracket | 3. Hose & tube assembly    |
| 4. Suction hose            | 5. Oil pressure sensor    | 6. Eye bolt                |
| 7. Oil cooler              | 8. Copper washer          | 9. Power steering oil pump |
| 10. Steering gear assembly | 11. Common bolt           | 12. Oil pump bracket       |
| 13. Clip                   |                           |                            |

A

B

C

D

E

F

**PS**

H

I

J

K

L

M

# SERVICE DATA AND SPECIFICATIONS (SDS)

## SERVICE DATA AND SPECIFICATIONS (SDS)

PFP:00030

### Steering Wheel

AGS0002C

End play of the axle direction for steering wheel	0 mm (0 in)
Steering wheel play on the outer circumference	0 - 35 mm (0 - 1.38 in) or less

### Steering Angle

AGS0002D

Tire size	17 and 18 inch tires	
Inner wheel Degree minute (Decimal degree)	Minimum	35°55' (35.9°)
	Nominal	38°55' (38.9°)
	Maximum	39°55' (39.9°)
Outer wheel Degree minute (Decimal degree)	Nominal	30°40' (30.7°)

### Steering Column

AGS0002E

Steering column length "L"	568 mm (22.36 in)
----------------------------	-------------------

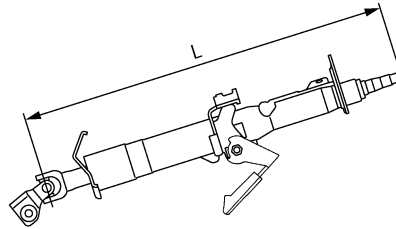

SGIA0306J

### Steering Outer Socket and Inner Socket

AGS0002F

Steering gear type	PR26AD	
Outer socket ball joint outer socket	Swinging torque	0.3 - 2.9 N·m (0.03 - 0.29 kg·m, 3 - 25 in·lb)
	Measurement on spring balance ● Measuring point: stud cotter pin hole	4.42 - 42.7 N (0.45 - 4.4 kg, 1.0 - 9.7 lb)
	Rotating torque	0.3 - 2.9 N·m (0.03 - 0.29 kg·m, 3 - 25 in·lb)
	Axial end play	0.5 mm (0.02 in) or less
Inner socket ball joint inner socket	Swinging torque	1.0 - 7.8 N·m (0.11 - 0.79 kg·m, 9 - 69 in·lb)
	Measurement on spring balance ● Measuring point: L mark see below, L=48.5 mm (1.91 in).	10 - 78 N (1.1 - 7.9 kg, 2.43 - 17.44 lb)
	Axial end play	0.2 mm (0.08 in) or less

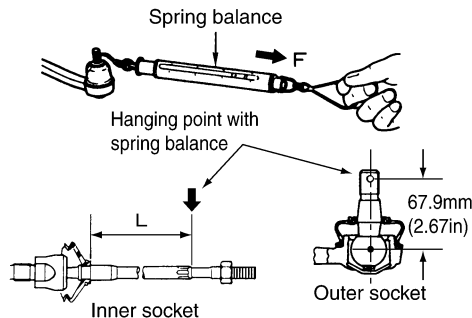

SGIA0358E

# SERVICE DATA AND SPECIFICATIONS (SDS)

Inner socket length "L"	107.7 mm (4.240 in)
-------------------------	---------------------

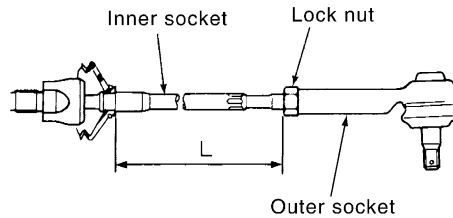

SGIA0167E

## Steering Gear

AGS0002G

Steering gear model	PR26AD
Rack neutral position, dimension "L" (rack stroke)	64.5 mm (2.54 in)

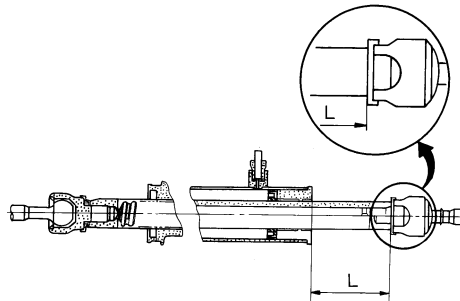

SGIA0629J

Rack sliding force	At the neutral point: Range within $\pm 11.5$ mm ( $\pm 0.453$ in) from the neutral position (in power ON)	Area average value	147 - 211 N (14.99 - 21.52 kg, 33.1 - 47.52 lb)
		Allowable variation	98 N (10 kg, 22 lb) or less
	Whole area (in power OFF)	Peak value	294 N (30.0 kg, 66 lb) or less
		Allowable variation	147 N (16 kg, 35 lb) or less

## Oil Pump

AGS0002H

Oil pump relief hydraulic pressure	9,600 - 10,200 kPa (98 - 104 kg/cm <sup>2</sup> , 1,390 - 1,480 psi)
------------------------------------	--

## Steering Fluid

AGS0002I

Fluid capacity	Approx. 1.0 ℓ (1-1/8 US qt, 7/8 Imp qt)
----------------	---

# SERVICE DATA AND SPECIFICATIONS (SDS)

---