

SECTION **RSU**  
 REAR SUSPENSION

A  
 B  
 C  
 D

RSU

CONTENTS

<b>PRECAUTIONS</b> .....	<b>2</b>	<b>SUSPENSION ARM</b> .....	<b>11</b>	F
Cautions .....	2	Removal and Installation .....	11	
<b>PREPARATION</b> .....	<b>3</b>	REMOVAL .....	11	G
Special Service Tools (SST) .....	3	INSPECTION AFTER REMOVAL .....	11	
Commercial Service Tools .....	3	INSTALLATION .....	12	H
<b>NOISE, VIBRATION AND HARSHNESS (NVH)</b>		<b>RADIUS ROD</b> .....	<b>13</b>	
<b>TROUBLESHOOTING</b> .....	<b>4</b>	Removal and Installation .....	13	I
NVH Troubleshooting Chart .....	4	REMOVAL .....	13	J
<b>REAR SUSPENSION ASSEMBLY</b> .....	<b>5</b>	INSPECTION AFTER REMOVAL .....	13	
On-Vehicle Inspection and Service .....	5	INSTALLATION .....	13	K
INSPECTION OF SUSPENSION ARM BALL		<b>FRONT LOWER LINK</b> .....	<b>14</b>	L
JOINT END PLAY .....	5	Removal and Installation .....	14	
SHOCK ABSORBER INSPECTION .....	5	REMOVAL .....	14	M
Wheel Alignment Inspection .....	5	INSPECTION AFTER REMOVAL .....	14	
DESCRIPTION .....	5	INSTALLATION .....	14	
PRELIMINARY CHECK .....	5	<b>REAR LOWER LINK &amp; COIL SPRING</b> .....	<b>15</b>	
CAMBER INSPECTION .....	5	Removal and Installation .....	15	
TOE-IN .....	6	REMOVAL .....	15	
Components .....	7	INSPECTION AFTER REMOVAL .....	15	
Removal and Installation .....	8	INSTALLATION .....	15	
REMOVAL .....	8	<b>STABILIZER BAR</b> .....	<b>16</b>	
INSTALLATION .....	8	Removal and Installation .....	16	
<b>SHOCK ABSORBER</b> .....	<b>9</b>	REMOVAL .....	16	
Removal and Installation .....	9	INSPECTION AFTER REMOVAL .....	16	
REMOVAL .....	9	INSTALLATION .....	16	
INSPECTION AFTER REMOVAL .....	9	<b>REAR SUSPENSION MEMBER</b> .....	<b>17</b>	
INSTALLATION .....	9	Removal and Installation .....	17	
Disassembly and Assembly .....	9	REMOVAL .....	17	
DISASSEMBLY .....	9	INSPECTION AFTER REMOVAL .....	17	
INSPECTION AFTER DISASSEMBLY .....	10	INSTALLATION .....	17	
ASSEMBLY .....	10	<b>SERVICE DATA AND SPECIFICATIONS (SDS)</b> .....	<b>18</b>	
		Wheel Alignment (Unladen*) .....	18	
		Ball Joint .....	18	
		Wheelarch Height (Unladen*) .....	18	

# PRECAUTIONS

---

## PRECAUTIONS

PFP:00001

### Cautions

AES000GQ

- When installing rubber bushings, final tightening must be carried out under unladen conditions with tires on level ground. Oil will shorten the life of rubber bushings. Be sure to wipe off any spilled oil.
- Unladen conditions mean that fuel, engine coolant and lubricant are full. Spare tire, jack, hand tools and mats are in designated positions.
- After servicing suspension parts, be sure to check wheel alignment.
- Caulking nuts are not reusable. Always use new ones when installing. Since new caulking nuts are pre-oiled, tighten as they are.

# PREPARATION

## PREPARATION

PFP:00002

### Special Service Tools (SST)

AES000GR

The actual shapes of Kent-Moore tools may differ from those of special service tools illustrated here.

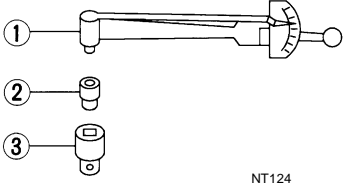
Tool number (Kent-Moore No.) Tool name	Description
ST3127S000 (See J25742-1) Preload gauge 1. GC91030000 Torque wrench (J25765) 2. HT62940000 ( — ) Socket adapter (1/2") 3. HT62900000 ( — ) Socket adapter (3/8")	 <p style="text-align: right;">NT124</p> Measuring rotating torque of ball joint

A  
B  
C  
D  
**RSU**

### Commercial Service Tools

AES000GS

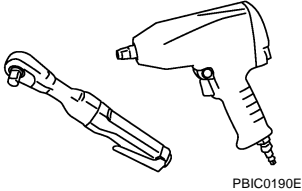
Tool name	Description
Power tool	 <p style="text-align: right;">PBIC0190E</p> <ul style="list-style-type: none"> <li>● Removing wheel nuts</li> <li>● Removing brake caliper assembly</li> <li>● Removing rear suspension component parts</li> </ul>

F  
G  
H  
I  
J  
K  
L  
M

# NOISE, VIBRATION AND HARSHNESS (NVH) TROUBLESHOOTING

## NOISE, VIBRATION AND HARSHNESS (NVH) TROUBLESHOOTING

PF0:00003

### NVH Troubleshooting Chart

AES0006T

Use chart below to help you find the cause of the symptom. If necessary, repair or replace these parts.

			RSU-7	RSU-9	—	—	—	RSU-7	RSU-18	RSU-16	NVH in PR section	NVH in RFD section	NVH in FAX and FSU sections	NVH in WT section	NVH in WT section	NVH in RAX section	NVH in BR section	NVH in PS section	
Reference page			RSU-7	RSU-9	—	—	—	RSU-7	RSU-18	RSU-16	NVH in PR section	NVH in RFD section	NVH in FAX and FSU sections	NVH in WT section	NVH in WT section	NVH in RAX section	NVH in BR section	NVH in PS section	
Possible cause and SUSPECTED PARTS			Improper installation, looseness	Shock absorber deformation, damage or deflection	Bushing or mounting deterioration	Parts interference	Spring fatigue	Suspension looseness	Incorrect wheel alignment	Stabilizer bar fatigue	PROPELLER SHAFT	DIFFERENTIAL	FRONT AXLE AND FRONT SUSPENSION	TIRES	ROAD WHEEL	DRIVE SHAFT	BRAKES	STEERING	
Symptom	REAR SUSPENSION	Noise	x	x	x	x	x	x			x	x	x	x	x	x	x	x	
		Shake	x	x	x	x			x			x		x	x	x	x	x	
		Vibration	x	x	x	x	x					x		x	x		x		x
		Shimmy	x	x	x	x				x				x	x	x		x	x
		Judder	x	x	x									x	x	x		x	x
		Poor quality ride or handling	x	x	x	x	x			x	x			x	x	x			

x: Applicable

# REAR SUSPENSION ASSEMBLY

## REAR SUSPENSION ASSEMBLY

PFP:55020

### On-Vehicle Inspection and Service

AES00018

Make sure the mounting conditions (looseness, back lash) of each component and component status (wear, damage) are normal.

### INSPECTION OF SUSPENSION ARM BALL JOINT END PLAY

- Measure axial end play of the suspension arm ball joint by prying between the suspension arm and axle with a iron bar or something similar.

**Axial end play : 0 mm (0 in)**

#### CAUTION:

Be careful not to damage ball joint boot.

### SHOCK ABSORBER INSPECTION

- Check shock absorber for oil leakage, damage and replace if necessary.

### Wheel Alignment Inspection DESCRIPTION

AES00019

- Measure wheel alignment under unladen conditions. "Unladen conditions" mean that fuel, engine coolant, and lubricant are full. Spare tire, jack, hand tools and mats are in designated positions.

#### PRELIMINARY CHECK

1. Check tires for improper air pressure and wear.
2. Check road wheels for runout.
3. Check wheel bearing axial end play.
4. Check suspension arm ball joint axial end play.
5. Check shock absorber operation.
6. Check each mounting point of axle and suspension for looseness and deformation.
7. Check each link, arm and member for cracks, deformation, and other damage.
8. Check vehicle posture.

#### CAMBER INSPECTION

- Measure camber of both right and left wheels with a suitable alignment gauge and adjust in accordance with the following procedures.

**Camber : Refer to [RSU-18, "Wheel Alignment \(Unladen\\*\)"](#) .**

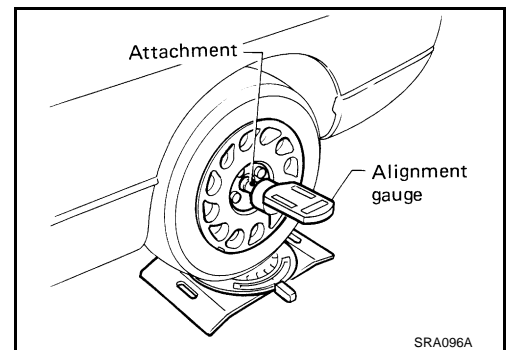

If outside the standard value, adjust with adjusting bolt on front lower link.

#### NOTE:

After adjusting camber, be sure to check toe-in.

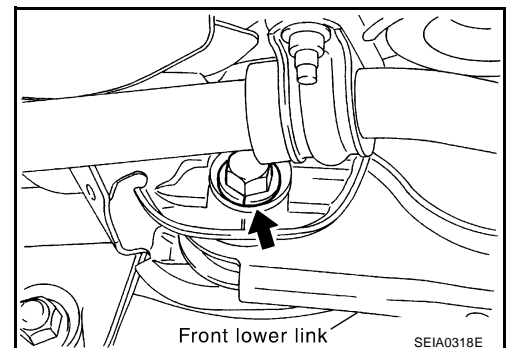

# REAR SUSPENSION ASSEMBLY

## TOE-IN

Measure toe-in using the following procedure. If out of specification, inspect and replace any damaged or worn rear suspension parts.

### WARNING:

- Always perform the following procedure on a flat surface.
- Make sure that no person is in front of vehicle before pushing it.

1. Bounce rear of vehicle up and down to stabilize the posture.
2. Push vehicle straight ahead about 5 m (16 ft).
3. Put a mark on base line of the tread (rear side) of both tires at the same height of hub center. These are measuring points.
4. Measure distance "A" (rear side).
5. Push vehicle slowly ahead to rotate wheels 180 degrees (1/2 turn).

If wheels have rotated more than 180 degrees (1/2 turn), try the above procedure again from the beginning. Never push vehicle backward.

6. Measure distance "B" (front side).

**Total toe-in:** Refer to [RSU-18, "Wheel Alignment \(Unladen\\*\)"](#) .

7. If outside the standard value, adjust with adjusting bolt in rear lower link.

### CAUTION:

Be sure to adjust equally on RH and LH side with adjusting bolt.

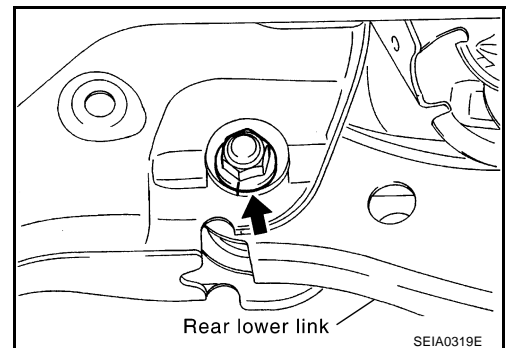
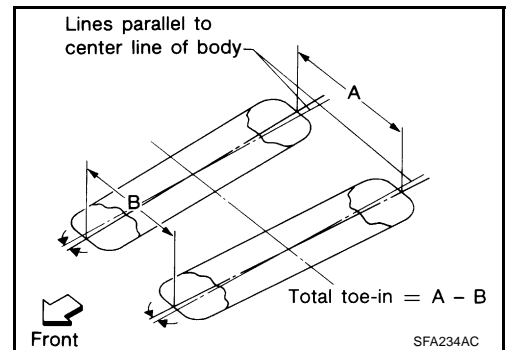
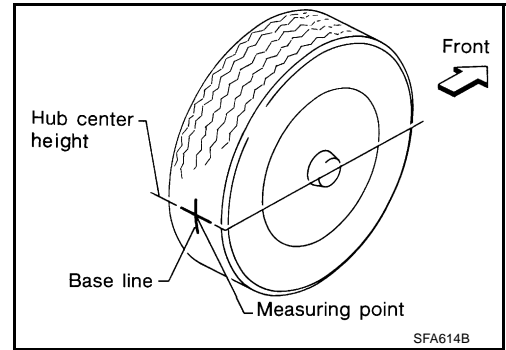



# REAR SUSPENSION ASSEMBLY

- |                             |  |                                |
|-----------------------------|--|--------------------------------|
| 1. Outer washer             | 2. Bushing A                                   | 3. Distance tube               |
| 4. Mounting seal bracket    | 5. Bushing B                                   | 6. Bound bumper cover          |
| 7. Bound bumper             | 8. Shock absorber                              | 9. Upper seat                  |
| 10. Coil spring             | 11. Rubber seat                                | 12. Rear lower link            |
| 13. Axle                    | 14. Front lower link                           | 15. Radius rod                 |
| 16. Suspension arm          | 17. Stabilizer connecting rod mounting bracket | 18. Rebound stopper            |
| 19. Shock absorber assembly | 20. Rear suspension member                     | 21. Member stay                |
| 22. Stabilizer bar          | 23. Stabilizer connecting rod                  | 24. Stabilizer bushing         |
| 25. Stabilizer clamp        | 26. Cotter pin                                 | 27. Front lower link protector |
| 28. Washer                  | 29. Stopper rubber                             |                                |

Refer to [GI-10, "Components"](#) , for the symbols in the figure.

## Removal and Installation

### REMOVAL

AES0001B

1. Remove tire with power tool.
2. Remove brake caliper with power tool. Hang it in a place where it will not interfere with work. Refer to [BR-34, "Removal and Installation of Brake Caliper Assembly"](#) . Then remove disc rotor.

#### **CAUTION:**

**Avoid depressing brake pedal while brake caliper is removed.**

3. Remove wheel sensor from axle. Refer to [BRC-105, "WHEEL SENSORS"](#) .
4. Remove center muffler and main muffler. Refer to [EX-3, "Removal and Installation"](#) .
5. Remove propeller shaft (AWD models).
6. Remove harness from rear final drive, suspension member and suspension arm.
7. Separate the attachment between parking brake cable and vehicle. Refer to [PB-3, "PARKING BRAKE CONTROL"](#) .
8. Remove rear lower link and coil spring. Refer to [RSU-15, "Removal and Installation"](#) .
9. Remove fixing nuts in upper side of mounting seal bracket.
10. Set jack under rear final drive (AWD models) or suspension member (2WD models).
11. Remove fixing bolts and nuts of member stay, then remove member stay from vehicle and suspension member.
12. Remove fixing nuts in rear side of suspension member, then remove rebound stopper.
13. Slowly lower jack, remove rear suspension assembly.

### INSTALLATION

Refer to [RSU-7, "Components"](#) , for tightening torque. Install in the reverse order of removal.

#### **CAUTION:**

**Refer to components and do not reuse non-reusable parts.**

- Perform final tightening of installation position of links (rubber bushing) under unladen conditions with tires on level ground. Check wheel alignment. Refer to [RSU-18, "Wheel Alignment \(Unladen\\*\)"](#) .
- After installation, check parking brake operation. Refer to [PB-2, "PARKING BRAKE SYSTEM"](#) .
- After installation, check condition of wheel sensor harness. Refer to [BRC-43, "WHEEL SENSORS"](#) .



# SHOCK ABSORBER

## SHOCK ABSORBER

PPF:56210

### Removal and Installation

AES000GY

#### REMOVAL

1. Remove tire with power tool.
2. Remove fixing bolt in lower side of shock absorber assembly with power tool.
3. Remove mounting seal bracket fixing nuts of shock absorber upper side with power tool and remove shock absorber assembly from vehicle.

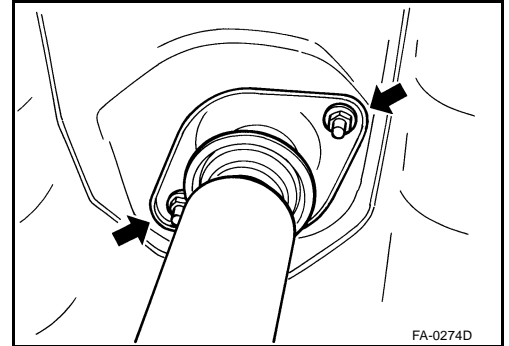

#### INSPECTION AFTER REMOVAL

- Check shock absorber for deformation, cracks or damage, and replace if necessary.
- Check piston rod for damage, uneven wear or distortion, and replace if necessary.
- Check welded and sealed areas for oil leakage, and replace if necessary.
- Check seal of mount seal bracket. If any crack, deformation or deterioration is found, replace the mount seal bracket as assembly.

#### INSTALLATION

- Refer to [RSU-7, "Components"](#) for tightening torque. Install in the reverse order of removal.

#### CAUTION:

Refer to component parts location and do not reuse non-reusable parts.

- Perform final tightening of shock absorber lower side (rubber bushing) under unladen conditions with tires on level ground. Check wheel alignment. Refer to [RSU-18, "Wheel Alignment \(Unladen\\*\)"](#) .

### Disassembly and Assembly

AES000GZ

#### DISASSEMBLY

#### CAUTION:

Make sure piston rod on shock absorber is not damaged when removing components from shock absorber.

1. Wrap a shop cloth around lower side of shock absorber and fix it in a vise.

#### CAUTION:

Do not set the cylindrical part of shock absorber in vise.

2. Secure piston rod tip so that piston rod does not turn, and remove piston rod lock nut.
3. Remove outer washer, bushing A, distance tube, mounting seal bracket, bushing B and bound bumper cover from shock absorber.
4. Remove bound bumper from bound bumper cover.

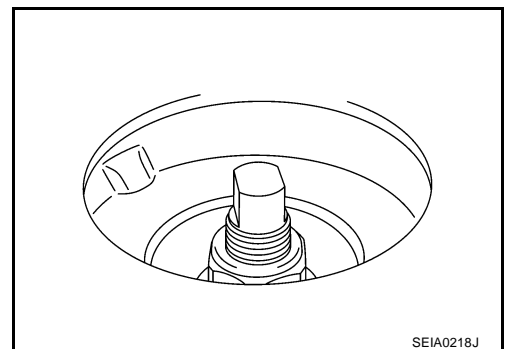

# SHOCK ABSORBER

---

## INSPECTION AFTER DISASSEMBLY

### Bound Bumper and Bushing

- Check bound bumper and bushing for cracks, deformation or other damage. Replace if necessary.

## ASSEMBLY

- Refer to [RSU-7, "Components"](#) for tightening torque. Install in the reverse order of removal.

### **CAUTION:**

- Refer to component parts location and do not reuse non-reusable parts.
- Make sure piston rod on shock absorber is not damaged when assembling components to shock absorber.

## SUSPENSION ARM

PFP:55501

### Removal and Installation

AES000H0

#### REMOVAL

1. Remove tire with power tool.
2. Remove coil spring. Refer to [RSU-15, "REAR LOWER LINK & COIL SPRING"](#).
3. Remove wheel sensor and sensor harness from axle and suspension arm. Refer to [BRC-43, "WHEEL SENSORS"](#).
4. Remove stabilizer connecting rod mounting bracket from suspension arm.
5. Set jack under front lower link.
6. Remove fuel filler tube fixing bolt (left side only). Refer to [FL-4, "FUEL LEVEL SENSOR UNIT, FUEL FILLER AND FUEL PUMP ASSEMBLY"](#).
7. Remove fixing nuts and bolts between suspension arm and rear suspension member.
8. Remove cotter pin of suspension arm ball joint, and loosen nut.
9. Use a ball joint remover (suitable tool) to remove suspension arm from axle. Be careful not to damage ball joint boot.

#### CAUTION:

**To prevent damage to ball joint threads and to prevent ball joint remover (suitable tool) from coming off, temporarily tighten lock nuts.**

10. Remove suspension arm from vehicle.

#### INSPECTION AFTER REMOVAL

##### Visual Inspection

- Check suspension arm and bushing for deformation, cracks, or other damage. If any non-standard condition is found, replace it.
- Check boot of ball joint for cracks, or other damage, and also for grease leakage.

##### Ball Joint Inspection

- Manually move ball stud to confirm it moves smoothly with no binding.

##### Swing Torque Inspection

#### NOTE:

Before measuring, move ball joint at least ten times by hand to check for smooth movement.

- Hook spring balance at cotter pin mounting hole. Confirm spring balance measurement value is within specifications when ball stud begins moving.

#### Swing torque:

**0.5 - 3.4 N·m (0.06 - 0.34 kg·m, 5 - 30 in·lb)**

#### Measured value of spring scale:

**7.94 - 54.0 N (0.81 - 5.5 kg, 1.79 - 12.1 lb)**

- If it is outside the specified range, replace suspension arm assembly.

##### Rotating Torque Inspection

- Attach mounting nut to ball stud. Make sure sliding torque is within specifications with a preload gauge (SST).

#### Rotating torque:

**0.5 - 3.4 N·m (0.06 - 0.34 kg·m, 5 - 30 in·lb)**

- If it is outside the specified range, replace suspension arm assembly.

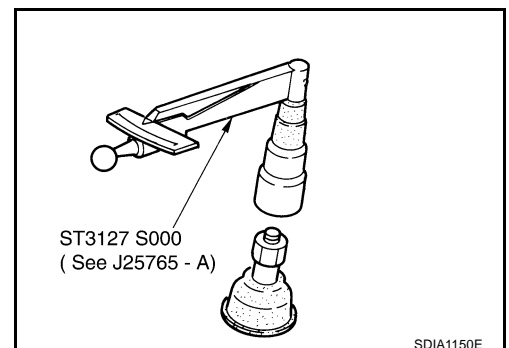
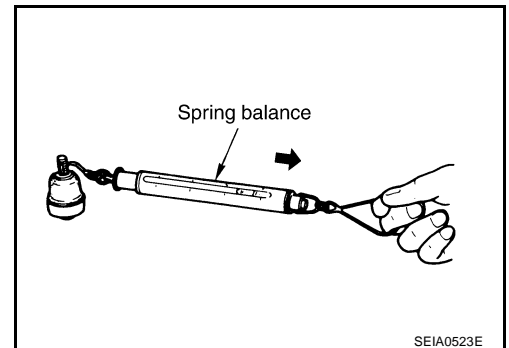

# SUSPENSION ARM

---

## Axial End Play Inspection

- Move tip of ball joint in axial direction to check for looseness.

**Axial end play : 0 mm (0 in)**

- If it is outside the specified range, replace suspension arm assembly.

## INSTALLATION

- Refer to [RSU-7, "Components"](#) , for tightening torque. Install in the reverse order of removal.

### **CAUTION:**

**Refer to component parts location and do not reuse non-reusable parts.**

- Perform final tightening of rear suspension member installation position (rubber bushing) under unladen conditions with tires on level ground. Check wheel alignment. Refer to [RSU-18, "Wheel Alignment \(Unladen\\*\)"](#) .

# RADIUS ROD

## RADIUS ROD

PF5:55110

### Removal and Installation

AES000H1

#### REMOVAL

1. Remove tire with power tool.
2. Remove coil spring. Refer to [RSU-15, "REAR LOWER LINK & COIL SPRING"](#) .
3. Remove wheel sensor and sensor harness from axle and suspension arm. Refer to [BRC-43, "WHEEL SENSORS"](#) .
4. Remove fixing bolt in lower side of shock absorber with power tool.
5. Remove fixing bolt and nut in axle side of front lower link with power tool.
6. Loosen fixing bolt and nut of front lower link in side of suspension member.
7. Remove fixing bolt and nut in axle side of radius rod.
8. Remove fixing bolt in rear suspension member side of radius rod with power tool, then remove radius rod from vehicle.

#### INSPECTION AFTER REMOVAL

- Check radius rod and bushing for any deformation, crack, or damage. Replace if necessary.

#### INSTALLATION

- Refer to [RSU-7, "Components"](#) for tightening torque. Tighten in the reverse order of removal.

#### **CAUTION:**

**Refer to component parts location and do not reuse non-reusable parts.**

- Perform final tightening of rear suspension member and axle installation position (rubber bushing) under unladen conditions with tires on level ground. Check wheel alignment. Refer to [RSU-5, "Wheel Alignment Inspection"](#) .

A

B

C

D

RSU

F

G

H

I

J

K

L

M

# FRONT LOWER LINK

---

## FRONT LOWER LINK

PFP:55110

### Removal and Installation

AES000H2

#### REMOVAL

1. Remove tire with power tool.
2. Remove coil spring. Refer to [RSU-15, "Removal and Installation"](#) .
3. Remove wheel sensor and sensor harness from axle and suspension arm. Refer to [BRC-43, "WHEEL SENSORS"](#) .
4. Remove fixing bolt between front lower link and shock absorber.
5. Remove stabilizer bushing and clamp from suspension member.
6. Remove fixing nut and bolt between front lower link and rear suspension member with power tool.
7. Remove fixing nut and bolt between front lower link and axle.
8. Remove front lower link from vehicle.
9. Remove front lower link protector.

#### INSPECTION AFTER REMOVAL

- Check front lower link and bushing for any deformation, crack, or damage. Replace if necessary.

#### INSTALLATION

- Refer to [RSU-7, "Components"](#) for tightening torque. Install in the reverse order of removal.

#### **CAUTION:**

**Refer to component parts location and do not reuse non-reusable parts.**

- Perform final tightening of rear suspension member and axle installation position (rubber bushing) under unladen conditions with tires on level ground. Check wheel alignment. Refer to [RSU-18, "Wheel Alignment \(Unladen\\*\)"](#) .

# REAR LOWER LINK & COIL SPRING

## REAR LOWER LINK & COIL SPRING

PFP:551B0

### Removal and Installation

AES000H3

#### REMOVAL

1. Remove tire with power tool.
2. Set jack under rear lower link.
3. Loosen fixing bolt and nut between rear lower link and suspension member, and then remove fixing bolt and nut between rear axle and rear lower link with power tool.
4. Slowly lower jack, then remove upper seat, coil spring and rubber seat from rear lower link.
5. Remove fixing bolt and nut between rear suspension member and rear lower link with power tool.

#### INSPECTION AFTER REMOVAL

- Check rear lower link, bushing and coil spring for deformation, cracks, and damage. Replace rear lower link and coil spring if necessary.

#### INSTALLATION

- Refer to [RSU-7, "Components"](#) for tightening torque. Install in the reverse order of removal.

#### CAUTION:

Refer to component parts location and do not reuse non-reusable parts.

- Make sure upper seat is attached as shown in the figure.

#### NOTE:

Insert bracket tabs (3) and the inside protrusion on upper seat into each other beforehand as shown in the figure.

- Match up rubber seat indentions and rear lower link grooves and attach.

#### NOTE:

Make sure spring is not upside down. The top and bottom are indicated by paint color.

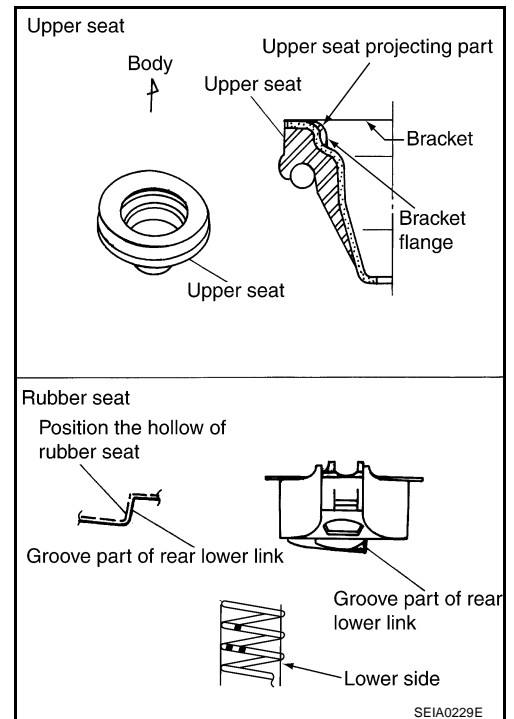

- Perform final tightening of rear suspension member and axle installation position (rubber bushing) under unladen conditions with tires on level ground. Check wheel alignment. Refer to [RSU-18, "Wheel Alignment \(Unladen\\*\)"](#) .

# STABILIZER BAR

## STABILIZER BAR

PFP:56230

### Removal and Installation

AES000H4

#### REMOVAL

1. Remove tire with power tool.
2. Remove lower side fixing nut on stabilizer connecting rod and remove stabilizer connecting rod from stabilizer bar.
3. Remove fixing nut on stabilizer clamp and remove stabilizer from vehicle with power tool.

#### INSPECTION AFTER REMOVAL

- Check stabilizer bar, stabilizer bushing, stabilizer clamp, stabilizer connecting rod, stabilizer connecting rod mounting bracket for any deformation, crack or damage. Replace if necessary.

#### INSTALLATION

- Refer to [RSU-7, "Components"](#) for tightening torque. Install in the reverse order of removal.

#### CAUTION:

**Refer to component parts location and do not reuse non-reusable parts.**

- Stabilizer bar uses pillow ball type connecting rod. Position ball joint with case on pillow ball head parallel to stabilizer bar.
- When the bushing and clamp are installed to stabilizer bar, position the bushing and clamp inside of the side slip prevention clamp.

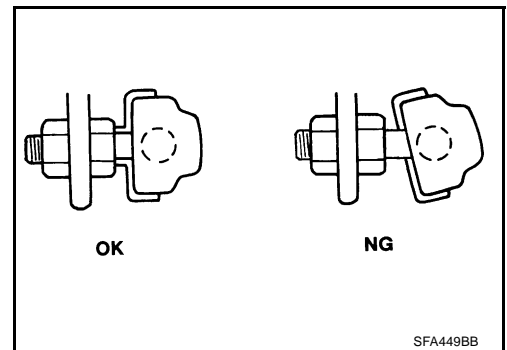



# REAR SUSPENSION MEMBER

## REAR SUSPENSION MEMBER

PFP:55501

### Removal and Installation

AES000H5

#### REMOVAL

1. Remove tire with power tool.
2. Remove brake caliper with power tool. Hang it in a place where it will not interfere with work. Refer to [BR-34, "Removal and Installation of Brake Caliper Assembly"](#) . Then remove disc rotor.  
**CAUTION:**  
**Avoid depressing brake pedal while brake caliper is removed.**
3. Remove wheel sensor and sensor harness from axle and suspension arm. Refer to [BRC-43, "WHEEL SENSORS"](#) .
4. Remove center muffler and main muffler. Refer to [EX-3, "Removal and Installation"](#) .
5. Remove stabilizer bar. Refer to [RSU-16, "Removal and Installation"](#) .
6. Remove drive shaft (AWD models). Refer to [RAX-7, "Removal and Installation"](#) .
7. Remove propeller shaft (AWD models). Refer to [PR-5, "Removal and Installation"](#) .
8. Remove harness from rear final drive (AWD models) and rear suspension member.
9. Remove final drive. Refer to [RFD-14, "REAR FINAL DRIVE ASSEMBLY"](#) .
10. Separate the attachment between parking brake cable and vehicle and rear suspension member.
11. Remove rear lower link and coil spring. Refer to [RSU-15, "Removal and Installation"](#) .
12. Remove fixing bolt in lower side of shock absorber.
13. Set jack under rear suspension member.
14. Remove fixing bolts and nuts of member stay, then remove member stay from vehicle and rear suspension member.
15. Remove fixing nuts in rear side of rear suspension member, then remove rebound stopper.
16. Slowly lower jack, then remove rear suspension member, suspension arm, radius rod, front lower link and axle from vehicle as a unit.
17. Remove fixing bolts and nuts, then remove suspension arm, front lower link, and radius rod from rear suspension member.
18. Remove electric controlled coupling breather hose from rear suspension member. Refer to [RFD-12, "Removal and Installation"](#) .

#### INSPECTION AFTER REMOVAL

- Check rear suspension member for deformation, cracks, and other damage and replace if necessary.

#### INSTALLATION

Refer to [RSU-7, "Components"](#) , for tightening torque. Install in the reverse order of removal.

#### CAUTION:

**Refer to component parts location and do not reuse non-reusable parts.**

- Perform final tightening of installation position of links (rubber bushing) under unladen conditions with tires on level ground. Check wheel alignment. Refer to [RSU-5, "Wheel Alignment Inspection"](#) .
- After installation, check parking brake operation. Refer to [PB-2, "PARKING BRAKE SYSTEM"](#) .
- After installation, check condition of wheel sensor harness. Refer to [BRC-43, "WHEEL SENSORS"](#) .

# SERVICE DATA AND SPECIFICATIONS (SDS)

## SERVICE DATA AND SPECIFICATIONS (SDS)

PFP:00030

### Wheel Alignment (Unladen\*)

AES000NJ

Camber Degree minute (Decimal degree)		Minimum	- 1° 16' (- 1.27°)
		Nominal	- 0° 46' (- 0.77°)
		Maximum	- 0° 16' (- 0.27°)
Total toe-in	Distance (A - B)	Minimum	1.4 mm (0.055 in)
		Nominal	3.2 mm (0.126 in)
		Maximum	5.0 mm (0.197 in)
	Angle (left plus right) Degree minute (Degree)	Minimum	3' (0.05°)
		Nominal	7' (0.12°)
		Maximum	11' (0.18°)

\*: Fuel, radiator coolant and engine oil full. Spare tire, jack, hand tools and mats are in designated positions.

### Ball Joint

AES000NK

Axial end play	0 mm (0 in)
Swing torque	0.5 - 3.4 N·m (0.06 - 0.34 kg-m, 5 - 30 in-lb)
Measurement on spring balance (cotter pinhole position)	7.94 - 54.0 N (0.81 - 5.5 kg, 1.79 - 12.1 lb)
Rotating torque	0.5 - 3.4 N·m (0.06 - 0.34 kg-m, 5 - 30 in-lb)

### Wheelarch Height (Unladen\*)

AES000NL

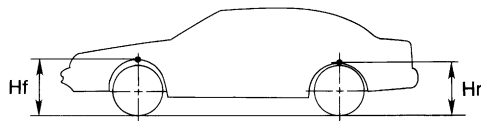

SFA818A

Grade	Except SE	SE
Applied model	235/65R18	
Front (Hf)	840 mm (33.07 in)	
Rear (Hr)	860 mm (33.86 in)	859 mm (33.82 in)

\*: Fuel, radiator coolant and engine oil full. Spare tire, jack, hand tools and mats are in designated positions.