

A
B
C

GW

SECTION

GLASS & WINDOW SYSTEM

CONTENTS

<p>PRECAUTION 2</p> <p>PRECAUTIONS 2</p> <p style="padding-left: 20px;">Precaution for Technicians Using Medical Electric.....2</p> <p style="padding-left: 20px;">Point to Be Checked Before Starting Maintenance Work2</p> <p style="padding-left: 20px;">Precaution for Supplemental Restraint System (SRS) "AIR BAG" and "SEAT BELT PRE-TENSIONER"2</p> <p style="padding-left: 20px;">Precaution for Procedure without Cowl Top Cover.....3</p> <p style="padding-left: 20px;">Handling for Adhesive and Primer3</p> <p>PREPARATION 4</p> <p>PREPARATION 4</p> <p style="padding-left: 20px;">Special Service Tools4</p> <p style="padding-left: 20px;">Commercial Service Tools4</p> <p>SYMPTOM DIAGNOSIS 5</p> <p>SQUEAK AND RATTLE TROUBLE DIAGNOSES 5</p> <p style="padding-left: 20px;">Work Flow5</p> <p style="padding-left: 20px;">Inspection Procedure7</p> <p style="padding-left: 20px;">Diagnostic Worksheet9</p> <p>REMOVAL AND INSTALLATION11</p> <p>WINDSHIELD GLASS11</p> <p style="padding-left: 20px;">Exploded View 11</p> <p style="padding-left: 20px;">Removal and Installation 12</p> <p style="padding-left: 20px;">Inspection 13</p>	<p>OPERA WINDOW14</p> <p style="padding-left: 20px;">Exploded View14</p> <p style="padding-left: 20px;">Removal and Installation15</p> <p style="padding-left: 20px;">Inspection15</p> <p>BACK DOOR WINDOW GLASS16</p> <p style="padding-left: 20px;">Exploded View16</p> <p style="padding-left: 20px;">Removal and Installation17</p> <p style="padding-left: 20px;">Inspection18</p> <p>FRONT DOOR GLASS19</p> <p style="padding-left: 20px;">Exploded View19</p> <p style="padding-left: 20px;">Removal and Installation19</p> <p style="padding-left: 20px;">Inspection and Adjustment20</p> <p>FRONT REGULATOR21</p> <p style="padding-left: 20px;">Exploded View21</p> <p style="padding-left: 20px;">Removal and Installation21</p> <p style="padding-left: 20px;">Disassembly and Assembly22</p> <p style="padding-left: 20px;">Inspection and Adjustment22</p> <p>REAR DOOR GLASS23</p> <p style="padding-left: 20px;">Exploded View23</p> <p style="padding-left: 20px;">Removal and Installation23</p> <p style="padding-left: 20px;">Inspection and Adjustment24</p> <p>REAR REGULATOR25</p> <p style="padding-left: 20px;">Exploded View25</p> <p style="padding-left: 20px;">Removal and Installation25</p> <p style="padding-left: 20px;">Disassembly and Assembly26</p> <p style="padding-left: 20px;">Inspection and Adjustment26</p>
--	---

A
B
C
D
E
F
G
H
I
J
GW
L
M
N
O
P

PRECAUTIONS

< PRECAUTION >

PRECAUTION

PRECAUTIONS

Precaution for Technicians Using Medical Electric

INFOID:000000007079159

OPERATION PROHIBITION

WARNING:

- Parts with strong magnet is used in this vehicle.
- Technicians using a medical electric device such as pacemaker must never perform operation on the vehicle, as magnetic field can affect the device function by approaching to such parts.

NORMAL CHARGE PRECAUTION

WARNING:

- If a technician uses a medical electric device such as an implantable cardiac pacemaker or an implantable cardioverter defibrillator, the possible effects on the devices must be checked with the device manufacturer before starting the charge operation.
- As radiated electromagnetic wave generated by on board charger at normal charge operation may effect medical electric devices, a technician using a medical electric device such as implantable cardiac pacemaker or an implantable cardioverter defibrillator must not enter the vehicle compartment (including luggage room) during normal charge operation.

Precaution at telematics system operation

WARNING:

- If a technician uses implantable cardiac pacemaker or implantable cardioverter defibrillator (ICD), avoid the device implanted part from approaching within approximately 220 mm (8.66 in) from interior/exterior antenna.
- The electromagnetic wave of TCU might affect the function of the implantable cardiac pacemaker or the implantable cardioverter defibrillator (ICD), when using the service, etc.
- If a technician uses other medical electric devices than implantable cardiac pacemaker or implantable cardioverter defibrillator(ICD), the electromagnetic wave of TCU might affect the function of the device. The possible effects on the devices must be checked with the device manufacturer before TCU use.

Precaution at intelligent key system operation

WARNING:

- If a technician uses implantable cardiac pacemaker or implantable cardioverter defibrillator (ICD), avoid the device implanted part from approaching within approximately 220 mm (8.66 in) from interior/exterior antenna.
- The electromagnetic wave of intelligent key might affect the function of the implantable cardiac pacemaker or the implantable cardioverter defibrillator (ICD), at door operation, at each request switch operation, or at engine starting.
- If a technician uses other medical electric devices than implantable cardiac pacemaker or implantable cardioverter defibrillator (ICD), the electromagnetic wave of intelligent key might affect the function of the device. The possible effects on the devices must be checked with the device manufacturer before intelligent key use.

Point to Be Checked Before Starting Maintenance Work

INFOID:000000007079475

The high voltage system may starts automatically. It is required to check that the timer air conditioner and timer charge (during EVSE connection) are not set before starting maintenance work.

NOTE:

If the timer air conditioner or timer charge (during EVSE connection) is set, the high voltage system starts automatically even when the power switch is in OFF state.

Precaution for Supplemental Restraint System (SRS) "AIR BAG" and "SEAT BELT PRE-TENSIONER"

INFOID:000000007035809

The Supplemental Restraint System such as "AIR BAG" and "SEAT BELT PRE-TENSIONER", used along with a front seat belt, helps to reduce the risk or severity of injury to the driver and front passenger for certain types of collision. This system includes seat belt switch inputs and dual stage front air bag modules. The SRS

PRECAUTIONS

< PRECAUTION >

system uses the seat belt switches to determine the front air bag deployment, and may only deploy one front air bag, depending on the severity of a collision and whether the front occupants are belted or unbelted. Information necessary to service the system safely is included in the "SRS AIR BAG" and "SEAT BELT" of this Service Manual.

WARNING:

Always observe the following items for preventing accidental activation.

- To avoid rendering the SRS inoperative, which could increase the risk of personal injury or death in the event of a collision that would result in air bag inflation, all maintenance must be performed by an authorized NISSAN/INFINITI dealer.
- Improper maintenance, including incorrect removal and installation of the SRS, can lead to personal injury caused by unintentional activation of the system. For removal of Spiral Cable and Air Bag Module, see "SRS AIR BAG".
- Never use electrical test equipment on any circuit related to the SRS unless instructed to in this Service Manual. SRS wiring harnesses can be identified by yellow and/or orange harnesses or harness connectors.

PRECAUTIONS WHEN USING POWER TOOLS (AIR OR ELECTRIC) AND HAMMERS

WARNING:

Always observe the following items for preventing accidental activation.

- When working near the Air Bag Diagnosis Sensor Unit or other Air Bag System sensors with the power switch ON, never use air or electric power tools or strike near the sensor(s) with a hammer. Heavy vibration could activate the sensor(s) and deploy the air bag(s), possibly causing serious injury.
- When using air or electric power tools or hammers, always switch the power switch OFF, disconnect the 12V battery, and wait at least 3 minutes before performing any service.

Precaution for Procedure without Cowl Top Cover

INFOID:000000006930129

When performing the procedure after removing cowl top cover, cover the lower end of windshield with urethane, etc to prevent damage to windshield.

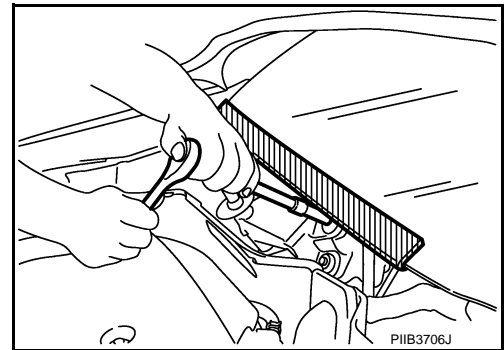

Handling for Adhesive and Primer

INFOID:000000006930130

- Do not use an adhesive which is past its usable date. Shelf life of this product is limited to six months after the date of manufacture. Carefully adhere to the expiration or manufacture date printed on the box.
- Keep primers and adhesive in a cool, dry place. Ideally, they should be stored in a refrigerator.
- Open the seal of the primer and adhesive just before application. Discard the remainder.
- Before application, be sure to shake the primer container to stir the contents. If any floating material is found, do not use it.
- If any primer or adhesive contacts the skin, wipe it off with gasoline or equivalent and wash the skin with soap.
- When using primer and adhesive, always observe the precautions in the instruction manual.

PREPARATION

< PREPARATION >

PREPARATION

PREPARATION

Special Service Tools

INFOID:000000007035810

The actual shapes of Kent-Moore tools may differ from those of special service tools illustrated here.

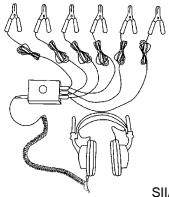
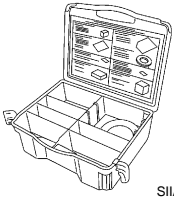
Tool number (Kent-Moore No.) Tool name	Description
<p>(J-39570) Chassis ear</p>  <p style="text-align: center;">SIIA0993E</p>	<p>Locates the noise</p>
<p>(J-43980) NISSAN Squeak and Rattle Kit</p>  <p style="text-align: center;">SIIA0994E</p>	<p>Repairs the cause of noise</p>

Commercial Service Tools

INFOID:000000006930131

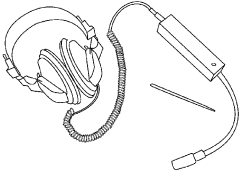
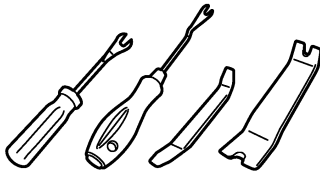
Tool name	Description
<p>Engine ear</p>  <p style="text-align: center;">SIIA0995E</p>	<p>Locates the noise</p>
<p>Remover tool</p>  <p style="text-align: center;">JMKIA3050ZZ</p>	<p>Removes clips, pawls and metal clips</p>

SQUEAK AND RATTLE TROUBLE DIAGNOSES

< SYMPTOM DIAGNOSIS >

SYMPTOM DIAGNOSIS

SQUEAK AND RATTLE TROUBLE DIAGNOSES

Work Flow

INFOID:000000007036118

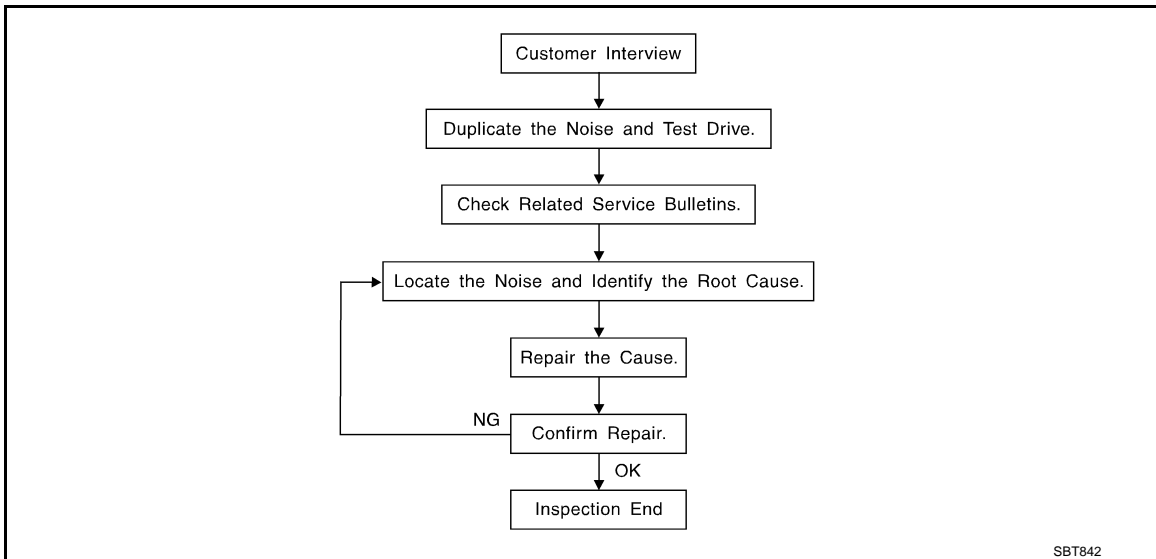

CUSTOMER INTERVIEW

Interview the customer if possible, to determine the conditions that exist when the noise occurs. Use the Diagnostic Worksheet during the interview to document the facts and conditions when the noise occurs and any customer comments. Refer to [GW-9, "Diagnostic Worksheet"](#). This information is necessary to duplicate the conditions that exist when the noise occurs.

- The customer may not be able to provide a detailed description or the location of the noise. Attempt to obtain all the facts and conditions that exist when the noise occurs (or does not occur).
- If there is more than one noise in the vehicle, perform a diagnosis and repair the noise that the customer is concerned about. This can be accomplished by performing a test drive with the customer.
- After identifying the type of noise, isolate the noise in terms of its characteristics. The noise characteristics are provided so that the customer, service adviser, and technician use the same language when describing the noise.
- Squeak – (Like tennis shoes on a clean floor)
Squeak characteristics include the light contact / fast movement / brought on by road conditions / hard surfaces = high-pitched noise / softer surfaces = low-pitched noises / edge to surface = chirping
- Creak – (Like walking on an old wooden floor)
Creak characteristics include firm contact / slow movement/twisting with a rotational movement / pitch dependent on materials / often brought on by activity.
- Rattle – (Like shaking a baby rattle)
Rattle characteristics include fast repeated contact / vibration or similar movement / loose parts/missing clip or fastener / incorrect clearance.
- Knock – (Like a knock on a door)
Knock characteristics include hollow sounds / sometimes repeating / often brought on by driver action.
- Tick – (Like a clock second hand)
Tick characteristics include gentle contacting of light materials / loose components / can be caused by driver action or road conditions.
- Thump – (Heavy, muffled knock noise)
Thump characteristics include softer knock / dull sounds often brought on by activity.
- Buzz – (Like a bumblebee)
Buzz characteristics include high frequency rattle / firm contact.
- Often the degree of acceptable noise level varies depending upon the person. A noise that a technician may judge as acceptable may be very irritating to a customer.
- Weather conditions, especially humidity and temperature, may have a great effect on noise level.

DUPLICATE THE NOISE AND TEST DRIVE

SQUEAK AND RATTLE TROUBLE DIAGNOSES

< SYMPTOM DIAGNOSIS >

If possible, drive the vehicle with the customer until the noise is duplicated. Note any additional information on the Diagnostic Worksheet regarding the conditions or location of the noise. This information can be used to duplicate the same conditions when the repair is reconfirmed.

If the noise can be duplicated easily during the test drive, to help identify the source of the noise, try to duplicate the noise with the vehicle stopped by doing one or all of the following items:

- 1) Close a door.
 - 2) Tap or push/pull around the area where the noise appears to be coming from.
 - 3) Rev the engine.
 - 4) Use a floor jack to recreate vehicle "twist".
 - 5) At idle, apply engine load (electrical load, half-clutch on M/T models, drive position on A/T models).
 - 6) Raise the vehicle on a hoist and hit a tire with a rubber hammer.
- Drive the vehicle and attempt to duplicate the conditions the customer states exist when the noise occurs.
 - If it is difficult to duplicate the noise, drive the vehicle slowly on an undulating or rough road to stress the vehicle body.

CHECK RELATED SERVICE BULLETINS

After verifying the customer concern or symptom, check ASIST for Technical Service Bulletins (TSBs) related to the concern or symptom.

If a TSB relates to the symptom, follow the procedure to repair the noise.

LOCATE THE NOISE AND IDENTIFY THE ROOT CAUSE

1. Narrow down the noise to a general area. To help pinpoint the source of the noise, use a listening tool (Chassis ear: J-39570, engine ear, and mechanics stethoscope).
2. Narrow down the noise to a more specific area and identify the cause of the noise by:
 - Removing the component(s) in the area that is / are suspected to be the cause of the noise.
Do not use too much force when removing clips and fasteners, otherwise clips and fasteners can be broken or lost during the repair, resulting in the creation of new noise.
 - Tapping or pushing/pulling the component(s) that is / are suspected to be the cause of the noise.
Do not tap or push/pull the component(s) with excessive force, otherwise the noise is eliminated only temporarily.
 - Feeling for a vibration by hand by touching the component(s) that is / are suspected to be the cause of the noise.
 - Placing a piece of paper between components that are suspected to be the cause of the noise.
 - Looking for loose components and contact marks.
Refer to [GW-7, "Inspection Procedure"](#).

REPAIR THE CAUSE

- If the cause is a loose component, tighten the component securely.
- If the cause is insufficient clearance between components:
 - Separate components by repositioning or loosening and retightening the components, if possible.
 - Insulate components with a suitable insulator such as urethane pads, foam blocks, felt cloth tape, or urethane tape. A NISSAN Squeak and Rattle Kit (J-43980) is available through the authorized NISSAN Parts Department.

CAUTION:

Never use excessive force as many components are constructed of plastic and may be damaged.

NOTE:

Always check with the Parts Department for the latest parts information.

The following materials are contained in the NISSAN Squeak and Rattle Kit (J-43980). Each item can be ordered separately as needed.

URETHANE PADS [1.5 mm (0.059 in) thick]

Insulates connectors, harness, etc.

- 76268-9E005: 100 × 135 mm (3.937 × 5.315 in)
- 76884-71L01: 60 × 85 mm (2.362 × 3.346 in)
- 76884-71L02: 15 × 25 mm (0.591 × 0.984 in)

INSULATOR (Foam blocks)

Insulates components from contact. Can be used to fill space behind a panel.

- 73982-9E000: 45 mm (1.772 in) thick, 50 × 50 mm (1.969 × 1.969 in)
- 73982-50Y00: 10 mm (0.394 in) thick, 50 × 50 mm (1.969 × 1.969 in)

INSULATOR (Light foam block)

80845-71L00: 30 mm (1.181 in) thick, 30 × 50 mm (1.181 × 1.969 in)

FELT CLOTHTAPE

SQUEAK AND RATTLE TROUBLE DIAGNOSES

< SYMPTOM DIAGNOSIS >

Used to insulate where movement does not occur. Ideal for instrument panel applications.

- 68370-4B000: 15 × 25 mm (0.591 × 0.984 in) pad
- 68239-13E00: 5 mm (0.197 in) wide tape roll

The following materials, not found in the kit, can also be used to repair squeaks and rattles.

UHMW (TEFLON) TAPE

Insulates where slight movement is present. Ideal for instrument panel applications.

SILICONE GREASE

Used in place of UHMW tape that is visible or does not fit. Only lasts a few months.

SILICONE SPRAY

Used when grease cannot be applied.

DUCT TAPE

Used to eliminate movement.

CONFIRM THE REPAIR

After repair is complete, test drive the vehicle to confirm that the cause of noise is repaired by test driving the vehicle. Operate the vehicle under the same conditions as when the noise originally occurred. Refer to the notes on the Diagnostic Worksheet.

Inspection Procedure

INFOID:000000007036119

Refer to Table of Contents for specific component removal and installation information.

INSTRUMENT PANEL

Most incidents are caused by contact and movement between:

1. The cluster lid A and instrument panel
2. Acrylic lens and combination meter housing
3. Instrument panel to front pillar garnish
4. Instrument panel to windshield
5. Instrument panel mounting pins
6. Wiring harnesses behind the combination meter
7. A/C defroster duct and duct joint

These incidents can usually be located by tapping or moving the components to duplicate the noise or by pressing on the components while driving to stop the noise. Most of these incidents can be repaired by applying felt cloth tape or silicon spray (in hard to reach areas). Urethane pads can be used to insulate wiring harness.

CAUTION:

Never use silicone spray to isolate a squeak or rattle. If the area is saturated with silicone, the recheck of repair becomes impossible.

CENTER CONSOLE

Components to check include:

1. Shifter assembly cover to finisher
2. A/C control unit and cluster lid C
3. Wiring harnesses behind audio and A/C control unit

The instrument panel repair and isolation procedures also apply to the center console.

DOORS

Check the following items:

1. Finisher and inner panel making a slapping noise
2. Inside handle escutcheon connection to door finisher
3. Wiring harnesses tapping
4. Door striker out of alignment causing a popping noise on starts and stops

Tapping, moving the components, or pressing on them while driving to duplicate the conditions can isolate many of these incidents. The areas can usually be insulated with felt cloth tape or insulator foam blocks from the NISSAN Squeak and Rattle Kit (J-43980) to repair the noise.

TRUNK

Trunk noises are often caused by a loose jack or loose items put into the trunk by the customer.

In addition check for the following items:

SQUEAK AND RATTLE TROUBLE DIAGNOSES

< SYMPTOM DIAGNOSIS >

1. Trunk lid dumpers out of adjustment
2. Trunk lid striker out of adjustment
3. Trunk lid torsion bars knocking together
4. A loose license plate or bracket

Most of these incidents can be repaired by adjusting, securing, or insulating the item(s) or component(s) causing the noise.

SUNROOF/HEADLINING

Noises in the sunroof / headlining area can often be traced to one of the following items:

1. Sunroof lid, rail, linkage, or seals making a rattle or light knocking noise
2. Sunvisor shaft shaking in the holder
3. Front or rear windshield touching headlining and squeaking

Again, pressing on the components to stop the noise while duplicating the conditions can isolate most of these incidents. Repairs usually consist of insulating with felt cloth tape.

SEATS

When isolating seat noise it is important to note the position the seat is in and the load placed on the seat when the noise occurs. These conditions should be duplicated when verifying and isolating the cause of the noise.

Causes of seat noise include:

1. Headrest rods and holder
2. A squeak between the seat pad cushion and frame
3. The rear seatback lock and bracket

These noises can be isolated by moving or pressing on the suspected components while duplicating the conditions under which the noise occurs. Most of these incidents can be repaired by repositioning the component or applying urethane tape to the contact area.

UNDERHOOD

Some interior noise may be caused by components under the hood or on the engine wall. The noise is then transmitted into the passenger compartment.

Causes of transmitted underhood noise include:

1. Any component mounted to the engine wall
2. Components that pass through the engine wall
3. Engine wall mounts and connectors
4. Loose radiator mounting pins
5. Hood bumpers out of adjustment
6. Hood striker out of adjustment

These noises can be difficult to isolate since they cannot be reached from the interior of the vehicle. The best method is to secure, move, or insulate one component at a time and test drive the vehicle. Also, engine RPM or load can be changed to isolate the noise. Repairs can usually be made by moving, adjusting, securing, or insulating the component causing the noise.

SQUEAK AND RATTLE TROUBLE DIAGNOSES

< SYMPTOM DIAGNOSIS >

Diagnostic Worksheet

INFOID:000000006930134



SQUEAK & RATTLE DIAGNOSTIC WORKSHEET

Dear Nissan Customer:

We are concerned about your satisfaction with your Nissan vehicle. Repairing a squeak or rattle sometimes can be very difficult. To help us fix your Nissan right the first time, please take a moment to note the area of the vehicle where the squeak or rattle occurs and under what conditions. You may be asked to take a test drive with a service advisor or technician to ensure we confirm the noise you are hearing.

I. WHERE DOES THE NOISE COME FROM? (circle the area of the vehicle)

The illustrations are for reference only, and may not reflect the actual configuration of your vehicle.

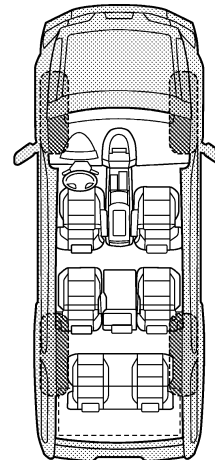
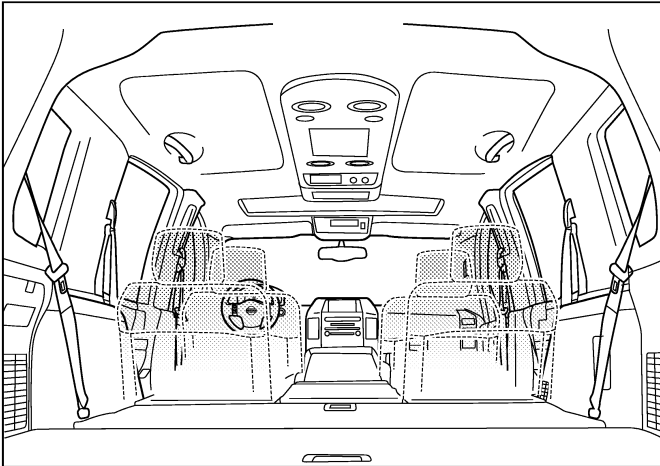
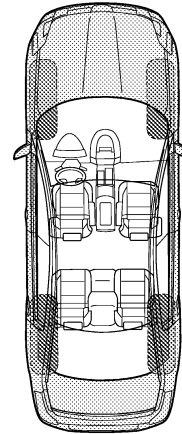
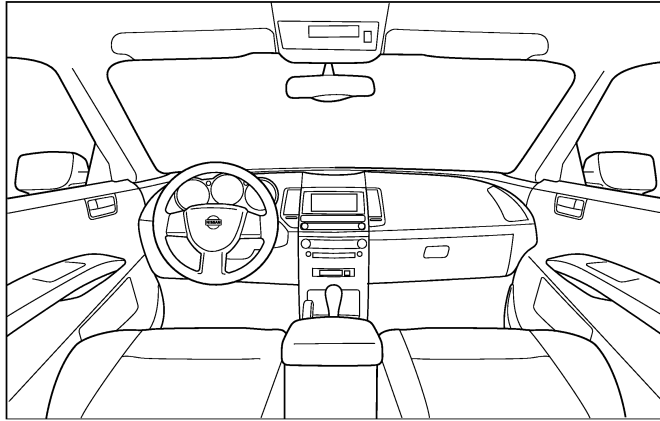

Continue to page 2 of the worksheet and briefly describe the location of the noise or rattle. In addition, please indicate the conditions which are present when the noise occurs.

PIIB8740E

A
B
C
D
E
F
G
H
I
J
GW
L
M
N
O
P

SQUEAK AND RATTLE TROUBLE DIAGNOSES

< SYMPTOM DIAGNOSIS >

SQUEAK & RATTLE DIAGNOSTIC WORKSHEET - page 2

Briefly describe the location where the noise occurs:

II. WHEN DOES IT OCCUR? (please check the boxes that apply)

- | | |
|---|--|
| <input type="checkbox"/> anytime | <input type="checkbox"/> after sitting out in the rain |
| <input type="checkbox"/> 1st time in the morning | <input type="checkbox"/> when it is raining or wet |
| <input type="checkbox"/> only when it is cold outside | <input type="checkbox"/> dry or dusty conditions |
| <input type="checkbox"/> only when it is hot outside | <input type="checkbox"/> other: |

III. WHEN DRIVING:

- through driveways
- over rough roads
- over speed bumps
- only about ____ mph
- on acceleration
- coming to a stop
- on turns: left, right or either (circle)
- with passengers or cargo
- other: _____
- after driving ____ miles or ____ minutes

IV. WHAT TYPE OF NOISE

- squeak (like tennis shoes on a clean floor)
- creak (like walking on an old wooden floor)
- rattle (like shaking a baby rattle)
- knock (like a knock at the door)
- tick (like a clock second hand)
- thump (heavy, muffled knock noise)
- buzz (like a bumble bee)

TO BE COMPLETED BY DEALERSHIP PERSONNEL

Test Drive Notes:

	YES	NO	Initials of person performing
Vehicle test driven with customer	<input type="checkbox"/>	<input type="checkbox"/>	_____
- Noise verified on test drive	<input type="checkbox"/>	<input type="checkbox"/>	_____
- Noise source located and repaired	<input type="checkbox"/>	<input type="checkbox"/>	_____
- Follow up test drive performed to confirm repair	<input type="checkbox"/>	<input type="checkbox"/>	_____

VIN: _____ Customer Name: _____
W.O.# _____ Date: _____

This form must be attached to Work Order

PIIB8742E

WINDSHIELD GLASS

< REMOVAL AND INSTALLATION >

REMOVAL AND INSTALLATION

WINDSHIELD GLASS

Exploded View

INFOID:000000006930135

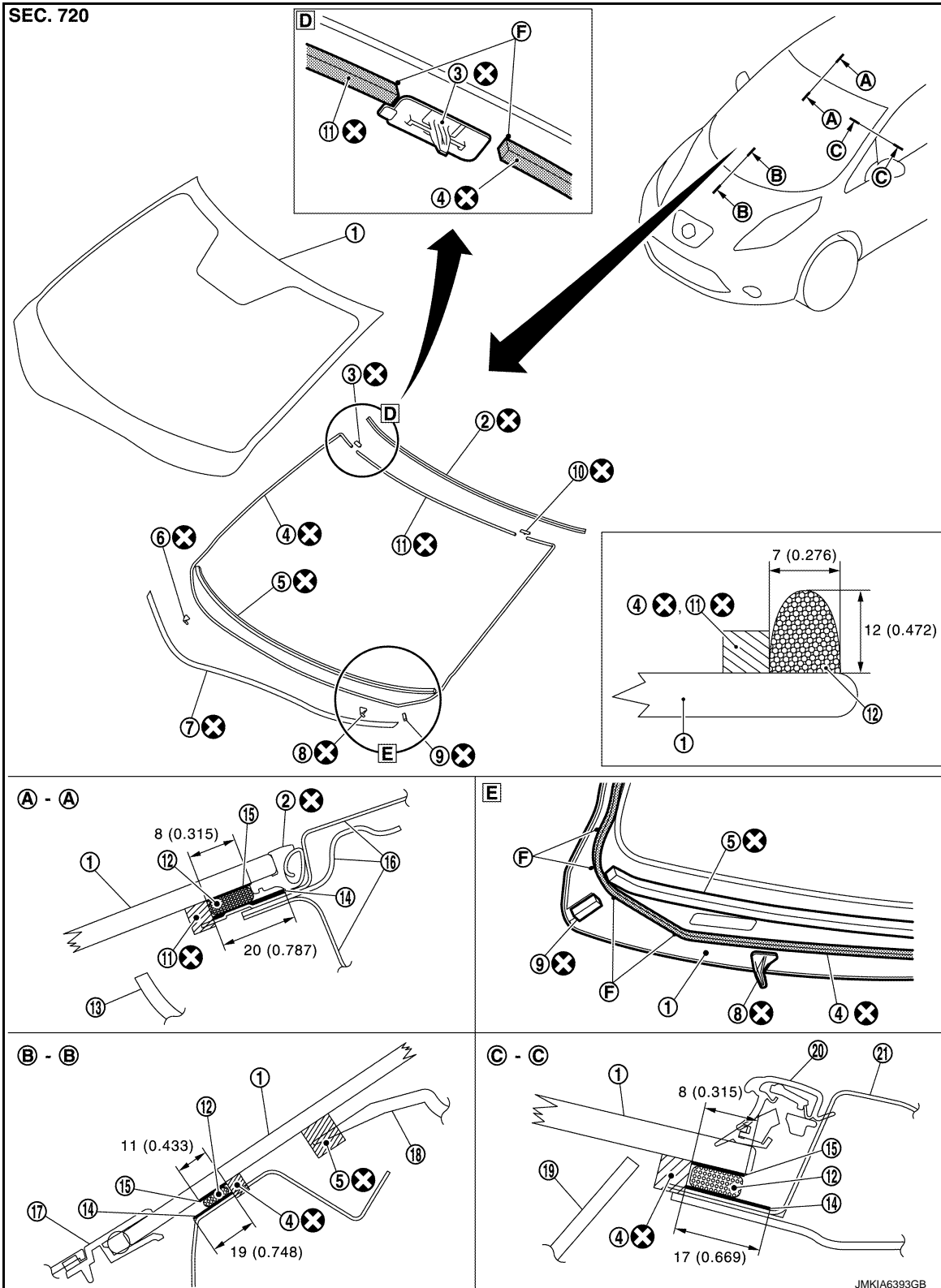

A

B

C

D

E

F

G

H

I

J

GW

L

M

N

O

P

WINDSHIELD GLASS

< REMOVAL AND INSTALLATION >

- | | | |
|-------------------------------|--------------------------------|---|
| 1. Windshield glass | 2. Windshield glass molding | 3. Upper clip RH |
| 4. Dam sealant rubber (lower) | 5. Glass insulator | 6. Lower clip RH |
| 7. Adhesive tape | 8. Lower clip LH | 9. Windshield lower spacer (Driver side only) |
| 10. Upper clip LH | 11. Dam sealant rubber (upper) | 12. Adhesive |
| 13. Headlining assembly | 14. Body primer | 15. Glass primer |
| 16. Roof assembly | 17. Cowl top cover | 18. Instrument panel assembly |
| 19. Front pillar finisher | 20. Roof side molding assembly | 21. Body side outer panel |

F : Black print mark

Unit: mm (in)

⊗ : Always replace after every disassembly.

Removal and Installation

INFOID:000000006930136

CAUTION:

Remove inside mirror only when windshield glass is not reusable.

REMOVAL

1. Remove front pillar garnish (LH and RH). Refer to [INT-20, "FRONT PILLAR GARNISH : Removal and Installation"](#).
2. Remove inside mirror assembly. Refer to [MIR-11, "Removal and Installation"](#).

CAUTION:

Replace inside mirror assembly after removal, when installing new windshield glass.

3. Remove partially the headlining (front edge). Refer to [INT-29, "Removal and Installation"](#).
4. Remove roof side molding assembly. Refer to [EXT-24, "Removal and Installation"](#).
5. Remove front wiper arm (LH and RH). Refer to [WW-49, "Removal and Installation"](#).
6. Remove front fender cover (LH and RH). Refer to [EXT-17, "Removal and Installation"](#).
7. Remove cowl top cover. Refer to [EXT-17, "Removal and Installation"](#).
8. Apply protective tape around the windshield glass to protect the painted surface from damage.
9. Remove glass using piano wire or power cutting tool (A) and an inflatable pump bag (B) after removing moldings.

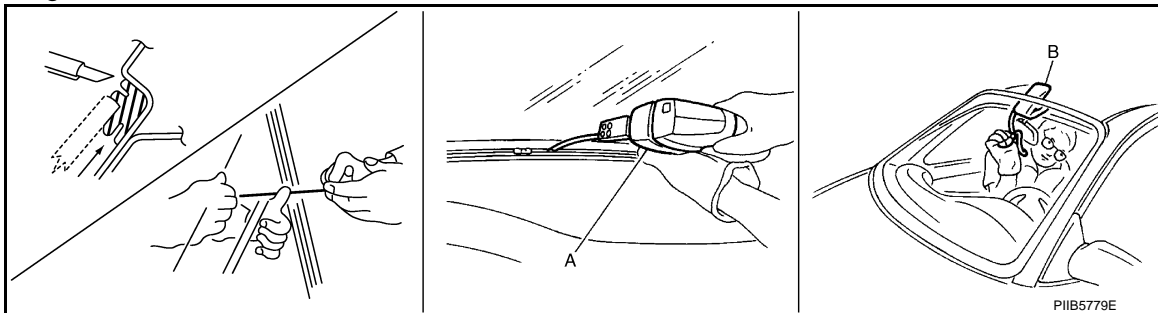

NOTE:

Mark the body and the glass with matching marks if the windshield glass is reused.

WARNING:

Always wear safety glasses and heavy gloves to help prevent injuries.

CAUTION:

- Never use a cutting knife or power cutting tool when the glass is reused to prevent damage to the glass.
- Be careful not to scratch the glass when removing.
- Never set or stand the glass on its edge. Small chips may develop into cracks.

INSTALLATION

- The dam sealant rubber should be installed in position.
- Use a genuine Nissan Urethane Adhesive Kit (if available) or an equivalent and follow the instructions provided with it.
- Open a door window while the urethane adhesive is curing. This prevents the glass from being forced out by passenger room air pressure when all door windows are closed.

WINDSHIELD GLASS

< REMOVAL AND INSTALLATION >

- Inform the customer that the vehicle should remain stationary until the urethane adhesive is completely cured (approximately 24 hours). Curing time varies with temperature and humidity.

WARNING:

- Keep heat and open flames away as primers and adhesive are flammable.
- The materials contained in the kit are harmful if swallowed, and may irritate skin and eyes. Never let them come in contact with the skin and eyes.
- Use in an open, well ventilated location. Never breathe the vapors. They may be harmful if inhaled. Move immediately to an area with fresh air if affected by vapor inhalation.
- Driving the vehicle before the urethane adhesive is completely cured may affect the performance of the windshield in an accident.

CAUTION:

- Perform adjustment of front wiper arms stop location. Refer to [WW-49, "Adjustment"](#).
- Never use an adhesive that is past its usable term. Shelf life of this product is limited to six months after the date of manufacture. Adhere carefully to the expiration or manufacture date printed on the box.
- Keep primers and adhesive in a cool, dry place. Ideally, they should be stored in a refrigerator.
- Never leave primers or adhesive cartridge unattended with their caps open or off.
- The vehicle should not be driven for 24 hours or more or until the urethane adhesive is completely cured. Curing time varies depending on temperature and humidity. The curing time increases under lower temperature and lower humidity.

Inspection

INFOID:000000006930137

REPAIRING WATER LEAKAGE FOR WINDSHIELD GLASS

Leakage can be repaired without removing the windshield glass.

Determine the extent of leakage if water is leaking between the urethane adhesive material and body or glass. This can be done by applying water to the windshield area while pushing glass outward.

Apply primer (if necessary) and then urethane adhesive to the leakage point to stop the leakage.

A
B
C
D
E
F
G
H
I
J
L
M
N
O
P

GW

OPERA WINDOW

< REMOVAL AND INSTALLATION >

OPERA WINDOW

Exploded View

INFOID:000000006930138

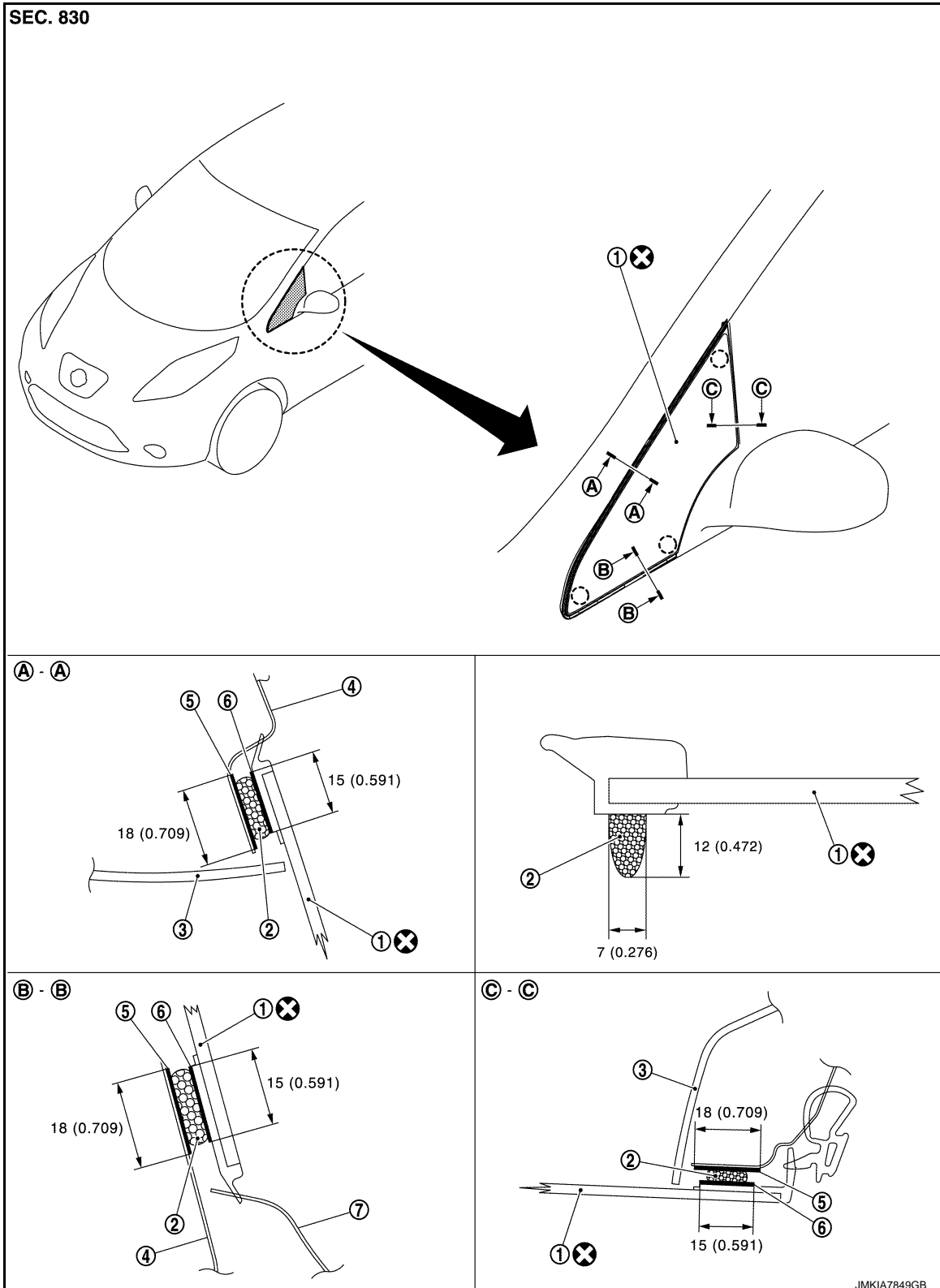

OPERA WINDOW

< REMOVAL AND INSTALLATION >

 : Clip

Unit: mm (in)

 : Always replace after every disassembly.

Removal and Installation

INFOID:000000006930139

CAUTION:

Replace the opera window glass assembly with a new part after removal as it cannot be reused.

REMOVAL

1. Remove front fender assembly. Refer to [DLK-151, "Removal and Installation"](#).
2. Remove front pillar garnish. Refer to [INT-20, "FRONT PILLAR GARNISH : Removal and Installation"](#).
3. Remove the opera window glass using piano wire or power cutting tool and an inflatable pump bag.

WARNING:

Always wear safety glasses and heavy gloves to help prevent injuries.

CAUTION:

- Never set or stand the glass on its edge. Small chips may develop into cracks.
- Apply protective tape around the opera window glass to protect the painted surface from damage.

INSTALLATION

- Use a genuine Nissan Urethane Adhesive Kit (if available) or an equivalent and follow the instructions provided with it.
- Open a door window while the urethane adhesive is curing. This prevents the glass from being forced out by passenger room air pressure when all door windows are closed.
- Inform the customer that the vehicle should remain stationary until the urethane adhesive is completely cured (approximately 24 hours). Curing time varies with temperature and humidity.

WARNING:

- Keep heat and open flames away as primers and adhesive are flammable.
- The materials contained in the kit are harmful if swallowed, and may irritate skin and eyes. Never let them come in contact with the skin and eyes.
- Use in an open, well ventilated location. Never breathe the vapors. They may be harmful if inhaled. Move immediately to an area with fresh air if affected by vapor inhalation.
- Driving the vehicle before the urethane adhesive is completely cured may affect the performance of the opera window glass in an accident.

CAUTION:

- Never use an adhesive that is past its usable term. Shelf life of this product is limited to six months after the date of manufacture. Adhere carefully to the expiration or manufacture date printed on the box.
- Keep primers and adhesive in a cool, dry place. Ideally, they should be stored in a refrigerator.
- Never leave primers or adhesive cartridge unattended with their caps open or off.
- The vehicle should not be driven for 24 hours or more or until the urethane adhesive is completely cured. Curing time varies depending on temperature and humidity. The curing time increases under lower temperature and lower humidity.

Inspection

INFOID:000000006930140

REPAIRING WATER LEAKAGE FOR OPERA WINDOW GLASS

Leakage can be repaired without removing the opera window glass.

Determine the extent of leakage if water is leaking between the urethane adhesive material and body or glass.

This can be done by applying water to the opera window glass area while pushing glass outward.

Apply primer (if necessary) and then urethane adhesive to the leakage point to stop the leakage.

BACK DOOR WINDOW GLASS

< REMOVAL AND INSTALLATION >

BACK DOOR WINDOW GLASS

Exploded View

INFOID:000000006930141

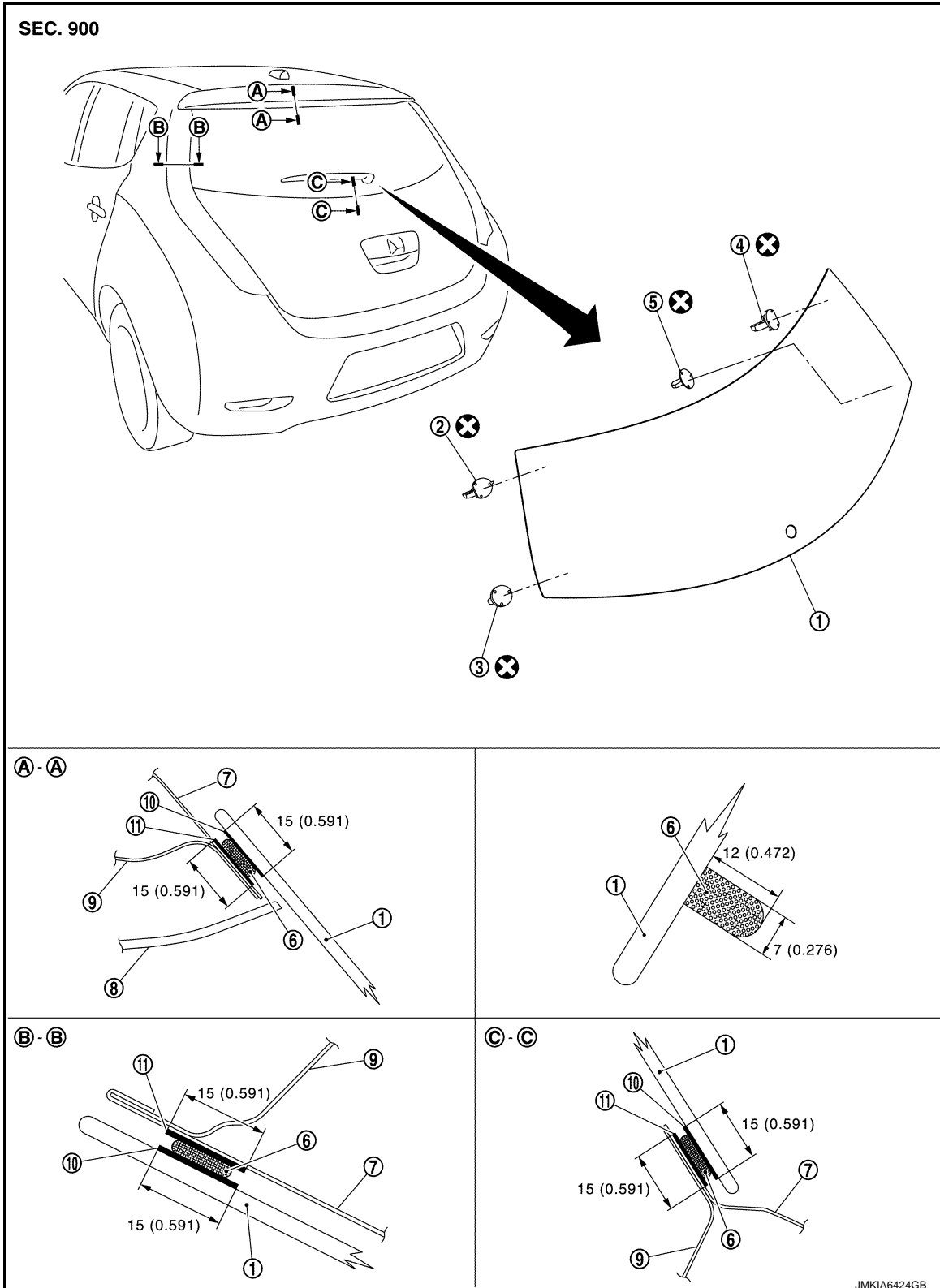

- | | | |
|----------------------------|----------------------------|----------------------------|
| 1. Back door window glass | 2. Glass holder LH (upper) | 3. Glass holder LH (lower) |
| 4. Glass holder RH (upper) | 5. Glass holder RH (lower) | 6. Adhesive |
| 7. Back door outer | 8. Back door finisher | 9. Back door inner |

BACK DOOR WINDOW GLASS

< REMOVAL AND INSTALLATION >

10. Glass primer

11. Body primer

Unit: mm (in)

⊗ : Always replace after every disassembly.

Removal and Installation

INFOID:000000006930142

REMOVAL

1. Remove back door upper finisher. Refer to [INT-37, "BACK DOOR UPPER FINISHER : Removal and Installation"](#).
2. Remove back door side finisher (LH and RH). Refer to [INT-38, "BACK DOOR SIDE FINISHER : Removal and Installation"](#).
3. Remove back door lower finisher. Refer to [INT-39, "BACK DOOR LOWER FINISHER : Removal and Installation"](#).
4. Remove rear wiper arm. Refer to [WW-56, "Removal and Installation"](#).
5. Remove rear spoiler. Refer to [EXT-34, "Removal and Installation"](#).
6. Remove the connectors and grounds for the back door window glass defogger.
7. Remove glass using piano wire or power cutting tool (A) and an inflatable pump bag (B) after removing molding using pliers.

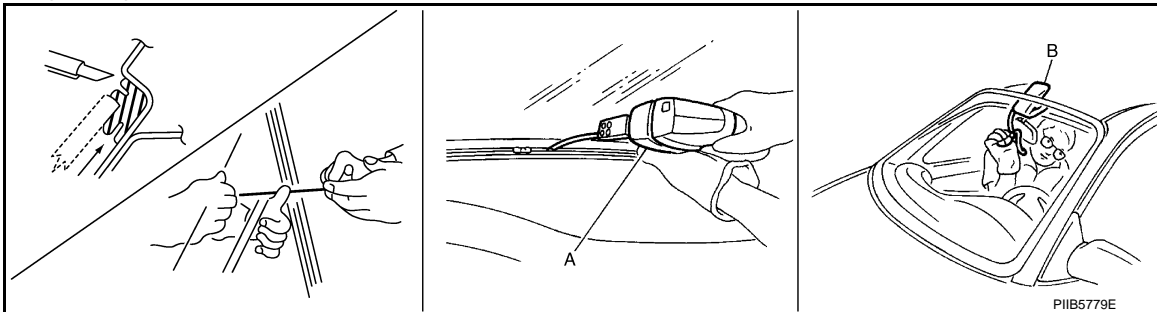

NOTE:

Mark the body and glass with a matching marks if the back door window glass is reused.

WARNING:

Always wear safety glasses and heavy gloves to help prevent injuries.

CAUTION:

- Never use a cutting knife or power cutting tool when the back door window glass is reused, to prevent damage to the glass.
- Be careful not to scratch the glass when removing.
- Never set or stand the glass on its edge. Small chips may develop into cracks.

INSTALLATION

- Use a Genuine Nissan Urethane Adhesive Kit (if available) or an equivalent and follow the instructions provided with it.
- Open a door window while the urethane adhesive is curing. This prevents the glass from being forced out by passenger compartment air pressure when all door windows are closed.
- Inform the customer that the vehicle should remain stationary until the urethane adhesive is completely cured (approximately 24 hours). Curing time varies with temperature and humidity.

WARNING:

- Keep heat and open flames away as primers and adhesive are flammable.
- The materials contained in the kit are harmful if swallowed, and may irritate skin and eyes. Never let them come in contact with the skin and eyes.
- Use in an open, well ventilated location. Never breathe the vapors. They may be harmful if inhaled. Move immediately to an area with fresh air if affected by vapor inhalation.
- Driving the vehicle before the urethane adhesive is completely cured may affect the performance of the back door window glass in an accident.

CAUTION:

- Perform adjustment of rear wiper arm stop location. Refer to [WW-56, "Adjustment"](#).
- Never use an adhesive that is past its usable term. Shelf life of this product is limited to six months after the date of manufacture. Adhere carefully to the expiration or manufacture date printed on the box.

BACK DOOR WINDOW GLASS

< REMOVAL AND INSTALLATION >

- **Keep primers and adhesive in a cool, dry place. Ideally, they should be stored in a refrigerator.**
- **Never leave primers or adhesive cartridge unattended with their caps open or off.**
- **The vehicle should not be driven for 24 hours or more or until the urethane adhesive is completely cured. Curing time varies depending on temperature and humidity. The curing time increases under lower temperature and lower humidity.**

Inspection

INFOID:000000006930143

REPAIRING WATER LEAKAGE FOR BACK DOOR WINDOW GLASS

Leakage can be repaired without removing the glass.

Determine the extent of leakage if water is leaking between the urethane adhesive material and body or glass.

This can be done by applying water to the back door window glass area while pushing glass outward.

Apply primer (if necessary) and then urethane adhesive to the leakage point to stop the leakage.

FRONT DOOR GLASS

< REMOVAL AND INSTALLATION >

FRONT DOOR GLASS

Exploded View

INFOID:000000006930144

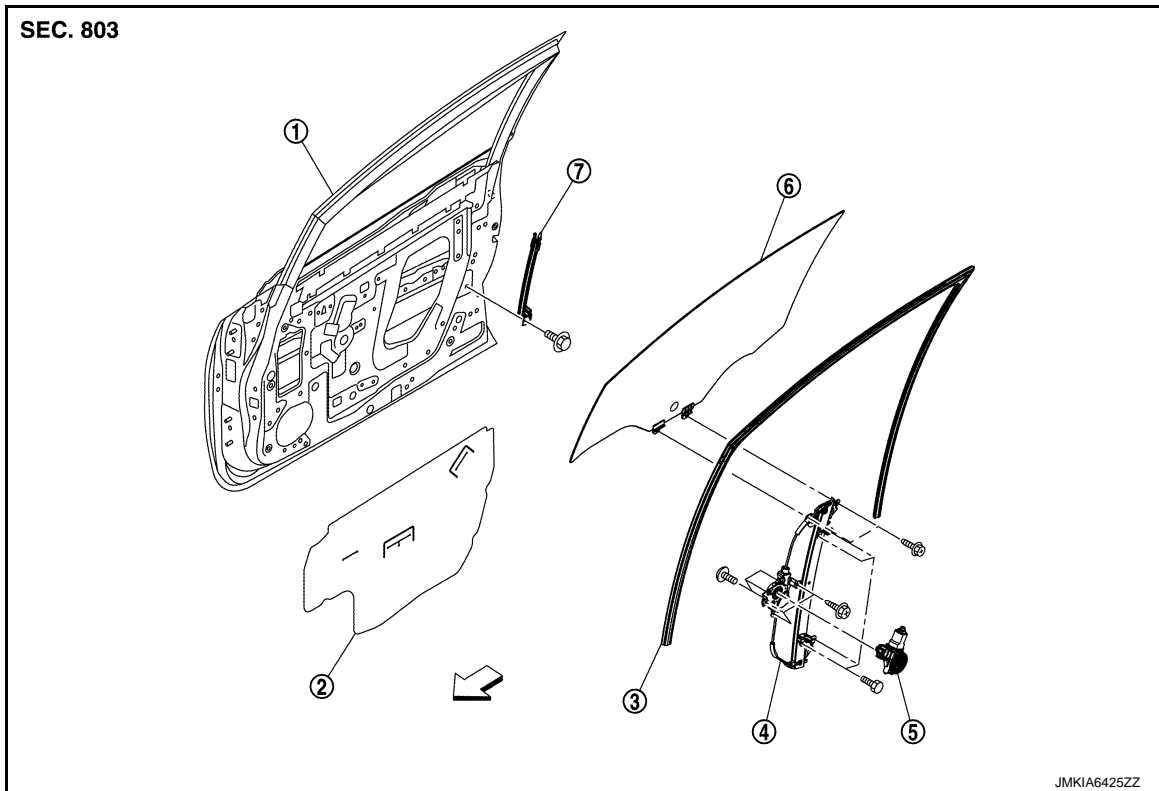

- | | | |
|-------------------------|-----------------------|-------------------------|
| 1. Front door panel | 2. Sealing screen | 3. Front door glass run |
| 4. Front door regulator | 5. Power window motor | 6. Front door glass |

7. Lower sash

↔ : Vehicle front

Removal and Installation

INFOID:000000006930145

REMOVAL

1. Fully open front door glass.
2. Remove front door finisher. Refer to [INT-13, "Removal and Installation"](#).
3. Disconnect front door speaker harness connector and remove sealing screen.
NOTE:
Cut the butyl-tape so that some parts of the butyl-tape do not remain on the sealing screen, if the sealing screen is reused.
4. Reconnect the power window main switch and then operate the power window main switch to raise or lower the door window until the glass mounting bolts can be seen.
5. Remove the glass mounting bolts.

A
B
C
D
E
F
G
H
I
J
L
M
N
O
P

GW

FRONT DOOR GLASS

< REMOVAL AND INSTALLATION >

6. Hold securely the front door glass and pull it out of the sash to remove the door glass as shown in the figure.

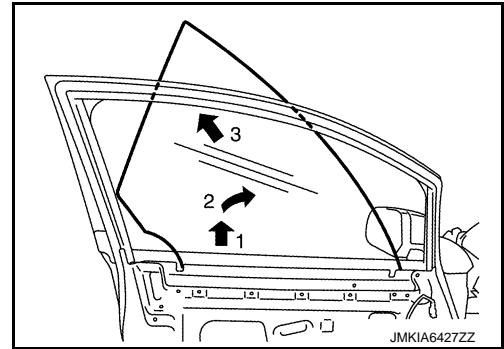

7. Remove lower sash.
8. Remove front door glass run.

INSTALLATION

Install in the reverse order of removal.

Inspection and Adjustment

INFOID:000000006930146

SYSTEM INITIALIZATION

Initialize the system if any of the following work is complete. Refer to [PWC-26, "Work Procedure"](#).

FITTING INSPECTION

- Check that the glass is fit securely into the sash groove.
- Lower the glass slightly [approximately 10 to 20 mm (0.394 to 0.787 in)], and check that the clearance to the sash is parallel. Loosen the regulator mounting bolts, guide rail mounting bolts, and glass and guide rail mounting bolts to correct the glass position if the clearance between the glass and sash is not parallel.

FRONT REGULATOR

< REMOVAL AND INSTALLATION >

FRONT REGULATOR

Exploded View

INFOID:000000006930147

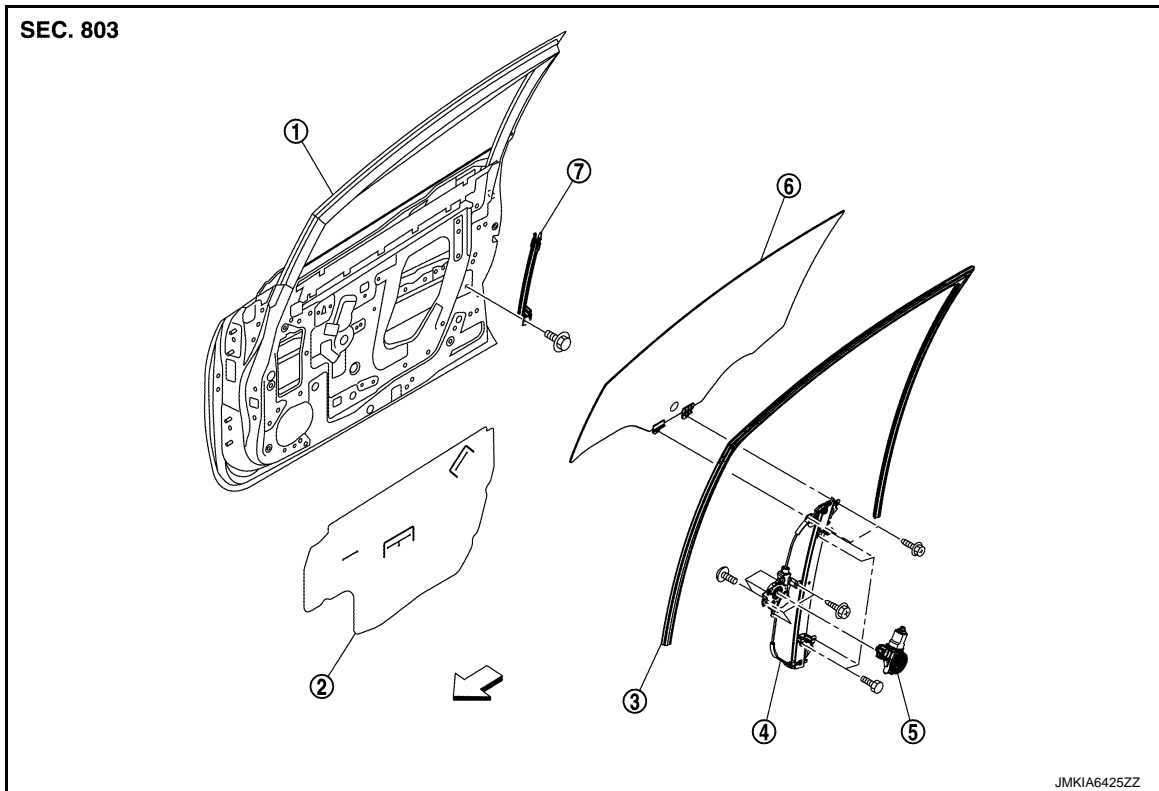

- | | | |
|-------------------------|-----------------------|-------------------------|
| 1. Front door panel | 2. Sealing screen | 3. Front door glass run |
| 4. Front door regulator | 5. Power window motor | 6. Front door glass |
| 7. Lower sash | | |

↔ : Vehicle front

A
B
C
D
E
F
G
H
I
J

GW

Removal and Installation

INFOID:000000006930148

REMOVAL

1. Remove the front door glass. Refer to [GW-19. "Removal and Installation"](#).
2. Disconnect the power window motor harness connector and harness fixing clip.
3. Remove the front door regulator assembly mounting bolts.
4. Remove the front door regulator assembly from the door panel as shown in the figure.

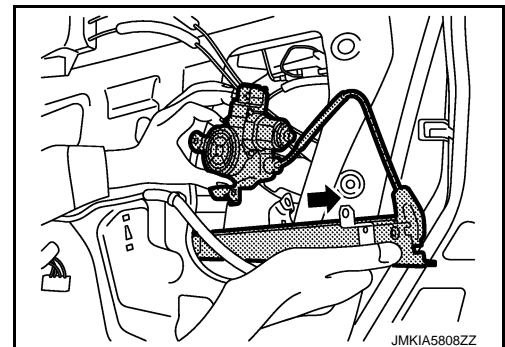

L
M
N
O
P

INSTALLATION

Install in the reverse order of removal.

FRONT REGULATOR

< REMOVAL AND INSTALLATION >

Disassembly and Assembly

INFOID:000000006930149

DISASSEMBLY

Remove the power window motor from the front door regulator.

INSPECTION AFTER REMOVAL

Check the front door regulator assembly for the following items. Replace or grease it if a malfunction is detected.

- Wire wear
- Regulator deformation

ASSEMBLY

Assemble in the reverse order of disassembly.

Inspection and Adjustment

INFOID:000000006930150

Inspection after removal

Check the front regulator for the following items. Replace or grease it if a malfunction is detected.

- Wire wear
- Front regulator deformation
- Grease condition for each sliding part

SYSTEM INITIALIZATION

Initialize the system if any of the following work is complete. Refer to [PWC-26. "Work Procedure"](#).

FITTING INSPECTION

- Check that the glass is fit securely into the sash groove.
- Lower the glass slightly [approximately 10 to 20 mm (0.394 to 0.787 in)], and check that the clearance to the sash is parallel. Loosen the regulator mounting bolts, guide rail mounting bolts, and glass and guide rail mounting bolts to correct the glass position if the clearance between the glass and sash is not parallel.

REAR DOOR GLASS

< REMOVAL AND INSTALLATION >

REAR DOOR GLASS

Exploded View

INFOID:000000006930151

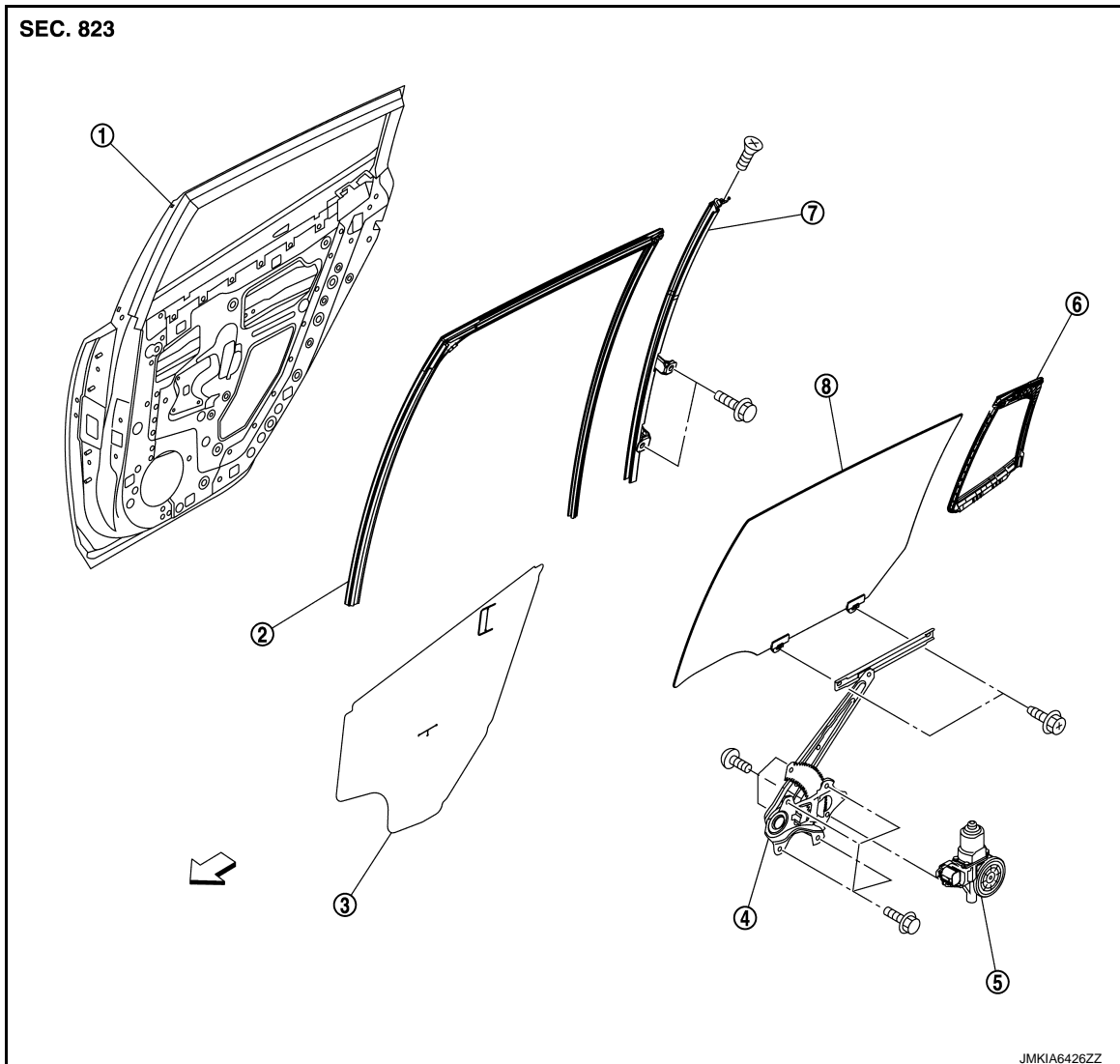

- | | | |
|------------------------|------------------------|--------------------|
| 1. Rear door panel | 2. Rear door glass run | 3. Sealing screen |
| 4. Rear door regulator | 5. Power window motor | 6. Partition glass |
| 7. Partition sash | 8. Rear door glass | |

↶ : Vehicle front

Removal and Installation

INFOID:000000006930152

REMOVAL

1. Remove rear door finisher. Refer to [INT-16. "Removal and Installation"](#).
2. Disconnect rear door speaker and remove the sealing screen.

NOTE:

Cut the butyl-tape so that some parts of the butyl-tape do not remain on the sealing screen, if the sealing screen is reused.

3. Fully open rear door glass.
4. Remove partition sash mounting bolts and screw.
5. Reconnect the power window switch and then operate the power window switch to raise the door window until the glass mounting bolts can be seen.

A

B

C

D

E

F

G

H

I

J

GW

L

M

N

O

P

REAR DOOR GLASS

< REMOVAL AND INSTALLATION >

6. Remove slightly the glass mounting bolts.
7. Operate the power window switch to lower the rear door glass.
8. Remove rear door glass run from partition sash.
9. Pull partition sash (1) out of the rear door panel as shown in the figure to remove.

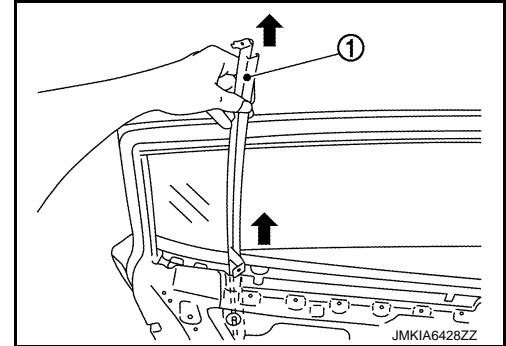

10. Remove rear door glass from the rear door panel as shown in the figure.

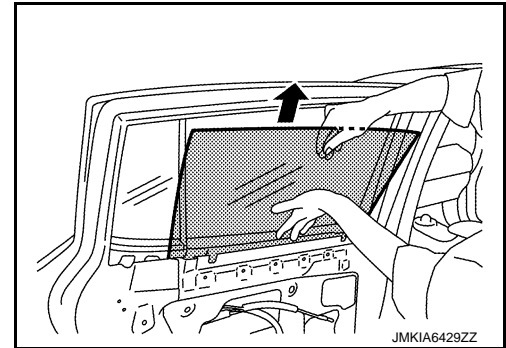

11. Remove partition glass.
 - a. Slide partition glass toward the direction of arrow 1.
 - b. Pull partition glass toward the direction of arrow 2 to remove.

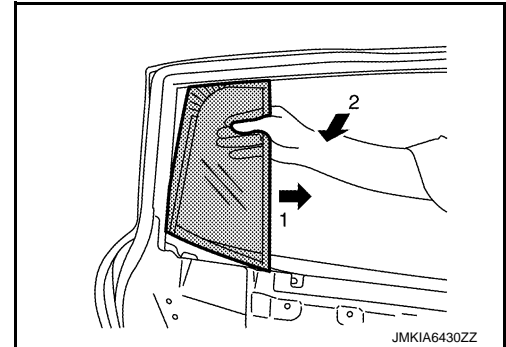

INSTALLATION

Install in the reverse order of removal.

Inspection and Adjustment

INFOID:000000006930153

FITTING INSPECTION

- Check that the glass is fit securely into the sash groove.
- Lower the glass slightly [approximately 10 to 20 mm (0.394 to 0.787 in)], and check that the clearance to the sash is parallel. Loosen the regulator mounting bolts, guide rail mounting bolts, and glass and guide rail mounting bolts to correct the glass position if the clearance between the glass and sash is not parallel.

REAR REGULATOR

< REMOVAL AND INSTALLATION >

REAR REGULATOR

Exploded View

INFOID:000000006930154

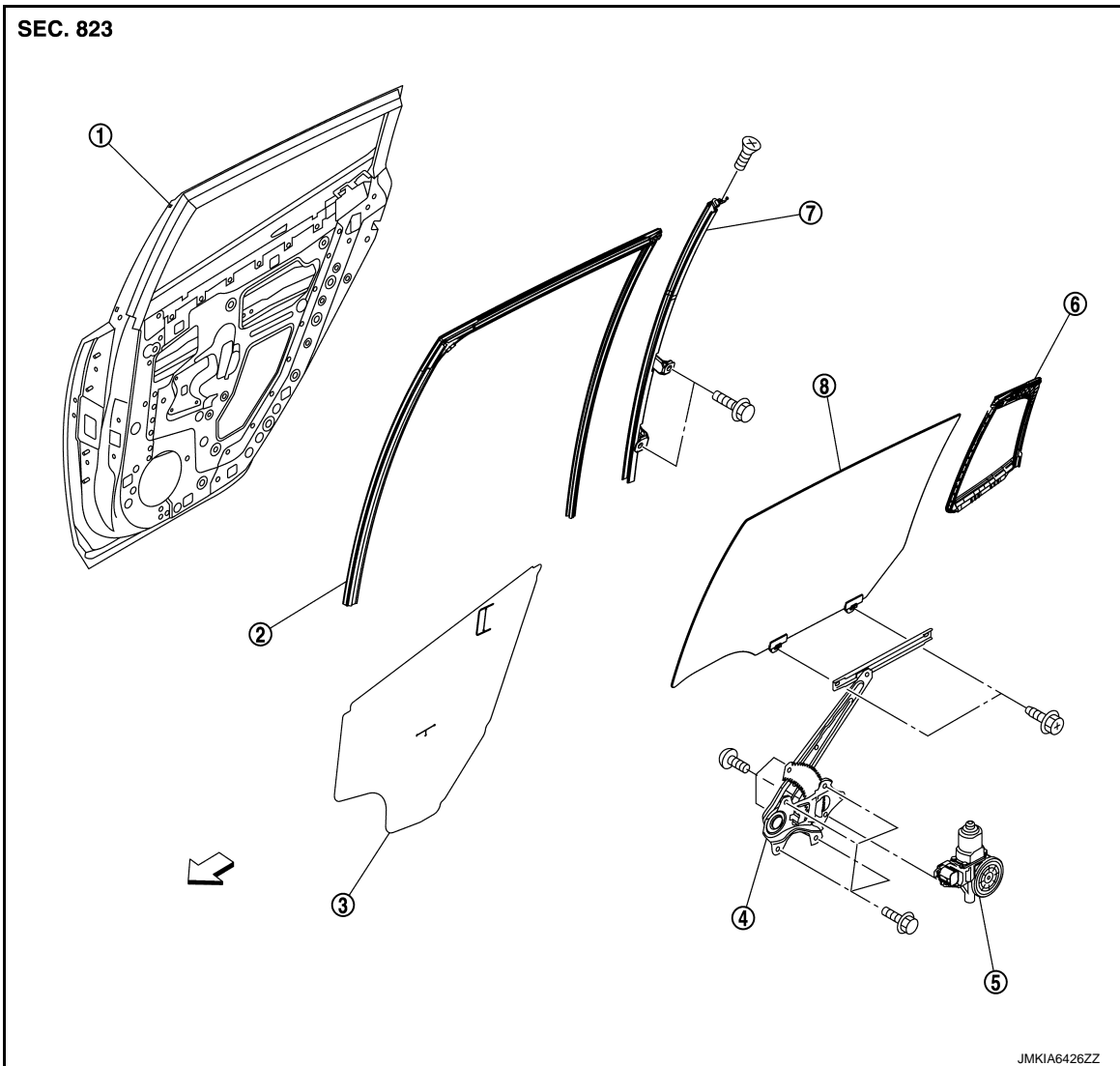

- | | | |
|------------------------|------------------------|--------------------|
| 1. Rear door panel | 2. Rear door glass run | 3. Sealing screen |
| 4. Rear door regulator | 5. Power window motor | 6. Partition glass |
| 7. Partition sash | 8. Rear door glass | |

↶ : Vehicle front

Removal and Installation

INFOID:000000006930155

REMOVAL

1. Remove rear door glass. Refer to [GW-23. "Removal and Installation"](#).
2. Disconnect the power window motor harness connector.

REAR REGULATOR

< REMOVAL AND INSTALLATION >

3. Remove the rear door regulator assembly mounting bolts and nuts, and then remove rear door regulator assembly from door panel as shown in the figure.

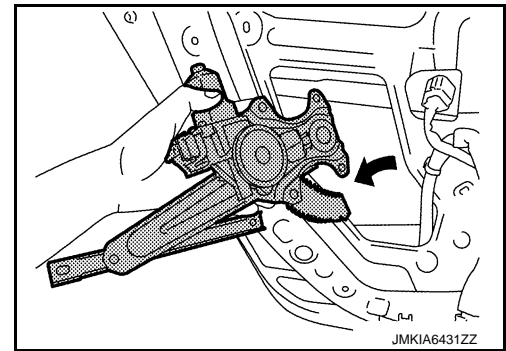

INSTALLATION

Install in the reverse order of removal.

Disassembly and Assembly

INFOID:000000006930156

DISASSEMBLY

Remove the power window motor from the rear door regulator.

INSPECTION AFTER REMOVAL

Check the rear door regulator assembly for the following items. Replace or grease it if a malfunction is detected.

- Wire wear
- Regulator deformation

ASSEMBLY

Assemble in the reverse order of disassembly.

Inspection and Adjustment

INFOID:000000006930157

Inspection after removal

Check the rear regulator assembly for the following items. Replace or grease it if a malfunction is detected.

- Wire wear
- Rear regulator deformation
- Grease condition for each sliding part

FITTING INSPECTION

- Check that the glass is fit securely into the sash groove.
- Lower the glass slightly [approximately 10 to 20 mm (0.394 to 0.787 in)], and check that the clearance to the sash is parallel. Loosen the regulator mounting bolts, guide rail mounting bolts, and glass and guide rail mounting bolts to correct the glass position if the clearance between the glass and sash is not parallel.