

SECTION **PWO**
POWER OUTLET

A
B
C
D
E
F
G
H
I
J
K
L
N
O
P

CONTENTS

PRECAUTION	2	Wiring Diagram	4
PRECAUTIONS	2	REMOVAL AND INSTALLATION	6
Precaution for Technicians Using Medical Electric.....	2	POWER SOCKET	6
Point to Be Checked Before Starting Maintenance		Exploded View	6
Work	2	Removal and Installation	6
Precaution for Supplemental Restraint System		SERVICE DATA AND SPECIFICATIONS	
(SRS) "AIR BAG" and "SEAT BELT PRE-TENSIONER"	2	(SDS)	8
Precaution for Removing 12V Battery	3	SERVICE DATA AND SPECIFICATIONS	
WIRING DIAGRAM	4	(SDS)	8
POWER SOCKET	4	Power Socket	8

PWO

PRECAUTIONS

< PRECAUTION >

PRECAUTION

PRECAUTIONS

Precaution for Technicians Using Medical Electric

INFOID:000000007078267

OPERATION PROHIBITION

WARNING:

- Parts with strong magnet is used in this vehicle.
- Technicians using a medical electric device such as pacemaker must never perform operation on the vehicle, as magnetic field can affect the device function by approaching to such parts.

NORMAL CHARGE PRECAUTION

WARNING:

- If a technician uses a medical electric device such as an implantable cardiac pacemaker or an implantable cardioverter defibrillator, the possible effects on the devices must be checked with the device manufacturer before starting the charge operation.
- As radiated electromagnetic wave generated by on board charger at normal charge operation may effect medical electric devices, a technician using a medical electric device such as implantable cardiac pacemaker or an implantable cardioverter defibrillator must not enter the vehicle compartment (including luggage room) during normal charge operation.

Precaution at telematics system operation

WARNING:

- If a technician uses implantable cardiac pacemaker or implantable cardioverter defibrillator (ICD), avoid the device implanted part from approaching within approximately 220 mm (8.66 in) from interior/exterior antenna.
- The electromagnetic wave of TCU might affect the function of the implantable cardiac pacemaker or the implantable cardioverter defibrillator (ICD), when using the service, etc.
- If a technician uses other medical electric devices than implantable cardiac pacemaker or implantable cardioverter defibrillator(ICD), the electromagnetic wave of TCU might affect the function of the device. The possible effects on the devices must be checked with the device manufacturer before TCU use.

Precaution at intelligent key system operation

WARNING:

- If a technician uses implantable cardiac pacemaker or implantable cardioverter defibrillator (ICD), avoid the device implanted part from approaching within approximately 220 mm (8.66 in) from interior/exterior antenna.
- The electromagnetic wave of intelligent key might affect the function of the implantable cardiac pacemaker or the implantable cardioverter defibrillator (ICD), at door operation, at each request switch operation, or at engine starting.
- If a technician uses other medical electric devices than implantable cardiac pacemaker or implantable cardioverter defibrillator (ICD), the electromagnetic wave of intelligent key might affect the function of the device. The possible effects on the devices must be checked with the device manufacturer before intelligent key use.

Point to Be Checked Before Starting Maintenance Work

INFOID:000000007080022

The high voltage system may starts automatically. It is required to check that the timer air conditioner and timer charge (during EVSE connection) are not set before starting maintenance work.

NOTE:

If the timer air conditioner or timer charge (during EVSE connection) is set, the high voltage system starts automatically even when the power switch is in OFF state.

Precaution for Supplemental Restraint System (SRS) "AIR BAG" and "SEAT BELT PRE-TENSIONER"

INFOID:000000007001210

The Supplemental Restraint System such as "AIR BAG" and "SEAT BELT PRE-TENSIONER", used along with a front seat belt, helps to reduce the risk or severity of injury to the driver and front passenger for certain types of collision. This system includes seat belt switch inputs and dual stage front air bag modules. The SRS

PRECAUTIONS

< PRECAUTION >

system uses the seat belt switches to determine the front air bag deployment, and may only deploy one front air bag, depending on the severity of a collision and whether the front occupants are belted or unbelted. Information necessary to service the system safely is included in the "SRS AIR BAG" and "SEAT BELT" of this Service Manual.

WARNING:

Always observe the following items for preventing accidental activation.

- To avoid rendering the SRS inoperative, which could increase the risk of personal injury or death in the event of a collision that would result in air bag inflation, all maintenance must be performed by an authorized NISSAN/INFINITI dealer.
- Improper maintenance, including incorrect removal and installation of the SRS, can lead to personal injury caused by unintentional activation of the system. For removal of Spiral Cable and Air Bag Module, see "SRS AIR BAG".
- Never use electrical test equipment on any circuit related to the SRS unless instructed to in this Service Manual. SRS wiring harnesses can be identified by yellow and/or orange harnesses or harness connectors.

PRECAUTIONS WHEN USING POWER TOOLS (AIR OR ELECTRIC) AND HAMMERS

WARNING:

Always observe the following items for preventing accidental activation.

- When working near the Air Bag Diagnosis Sensor Unit or other Air Bag System sensors with the power switch ON, never use air or electric power tools or strike near the sensor(s) with a hammer. Heavy vibration could activate the sensor(s) and deploy the air bag(s), possibly causing serious injury.
- When using air or electric power tools or hammers, always switch the power switch OFF, disconnect the 12V battery, and wait at least 3 minutes before performing any service.

Precaution for Removing 12V Battery

INFOID:000000006968192

When removing the 12V battery, turn ON/OFF the power switch and check that the charging status indicator does not blink. The 12V battery must be removed within one hour after checking the indicator lamp.

NOTE:

- The automatic 12V battery charge control may start even when the power switch is in OFF state.
- The automatic 12V battery charge control does not start within approximately one hour when the power switch is turned ON/OFF.

A
B
C
D
E
F
G
H
I
J
K
L

PWO

N
O
P

POWER SOCKET

< WIRING DIAGRAM >

WIRING DIAGRAM

POWER SOCKET

Wiring Diagram

INFOID:000000006968193

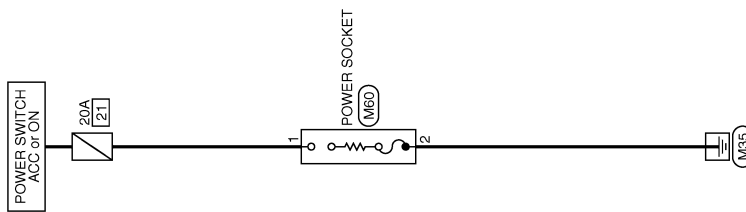

POWER SOCKET

2010/10/29

JCMWA6916GB

POWER SOCKET

< WIRING DIAGRAM >

A
B
C
D
E
F
G
H
I
J
K
L
N
O
P

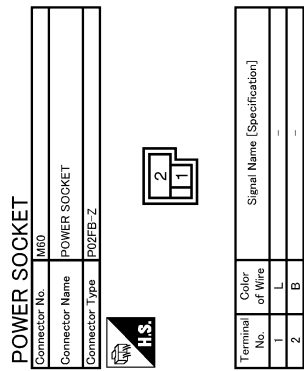

PWO

JCMWA6917GB

POWER SOCKET

< REMOVAL AND INSTALLATION >

REMOVAL AND INSTALLATION

POWER SOCKET

Exploded View

INFOID:000000006968194

- 1 : Ring
- 2 : Inner socket

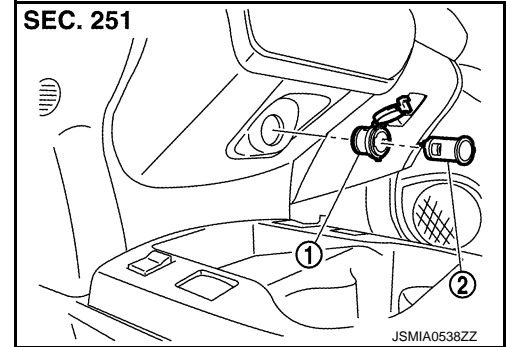

Removal and Installation

INFOID:000000006968195

REMOVAL

1. Remove cluster lid C. Refer to [IP-13, "Removal and Installation"](#).
2. Disconnect power socket connector.
3. Pull out inner socket (1) by pushing the pawl (B) of the ring (2) from the inner socket hole (square) (A).

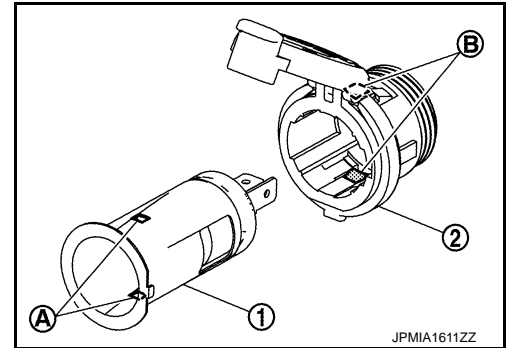

4. Press the ring pawl from the back of the cluster lower panel to remove the ring.

 : Pawl

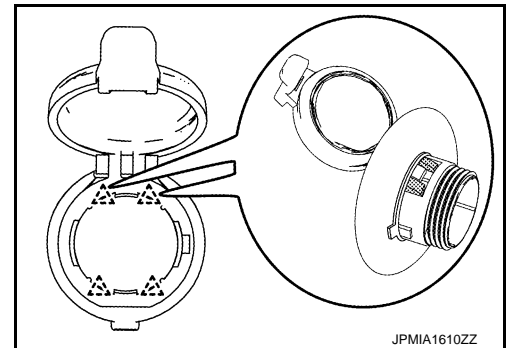

INSTALLATION

Note the following, and install in the reverse order of removal.

POWER SOCKET

< REMOVAL AND INSTALLATION >

Align the cut outs of inner socket, ring and cluster lower panel.

A : Cut out

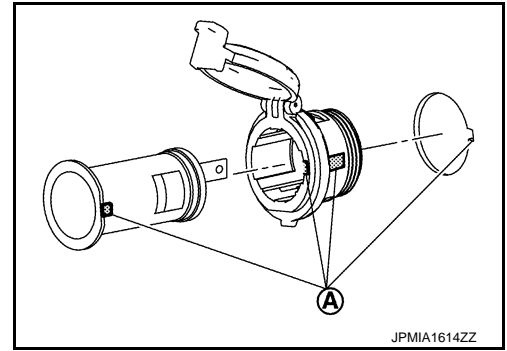

A

B

C

D

E

F

G

H

I

J

K

L

PWO

N

O

P

SERVICE DATA AND SPECIFICATIONS (SDS)

< SERVICE DATA AND SPECIFICATIONS (SDS)

SERVICE DATA AND SPECIFICATIONS (SDS)

SERVICE DATA AND SPECIFICATIONS (SDS)

Power Socket

INFOID:000000006968196

Rated voltage	DC 12 V
Maximum electric capacity	120 W or less (Total)
Maximum current	10 A or less (Total)