

SECTION **SB**  
SEAT BELT

A  
B  
C  
D  
E  
F  
G  
SB  
I  
J  
K  
L  
M  
N  
O  
P

CONTENTS

<b>PRECAUTION</b> .....	2	<b>SEAT BELT BUCKLE</b> .....	10
<b>PRECAUTIONS</b> .....	2	SEAT BELT BUCKLE : Removal and Installation....	10
Precaution for Technicians Using Medical Electric.....	2	SEAT BELT BUCKLE : Inspection .....	10
Point to Be Checked Before Starting Maintenance		<b>REAR SEAT BELT</b> .....	11
Work .....	2	Exploded View .....	11
Precaution for Supplemental Restraint System		<b>SEAT BELT RETRACTOR</b> .....	12
(SRS) "AIR BAG" and "SEAT BELT PRE-TENSIONER" .....	2	SEAT BELT RETRACTOR : Removal and Installation .....	12
Precaution for Seat Belt Service .....	3	SEAT BELT RETRACTOR : Inspection .....	13
<b>REMOVAL AND INSTALLATION</b> .....	4	<b>SEAT BELT BUCKLE</b> .....	15
<b>FRONT SEAT BELT</b> .....	4	SEAT BELT BUCKLE : Removal and Installation....	15
Exploded View .....	4	SEAT BELT BUCKLE : Inspection .....	15
<b>SEAT BELT RETRACTOR</b> .....	5	<b>SEAT BELT HOOK</b> .....	15
SEAT BELT RETRACTOR : Removal and Installation .....	5	SEAT BELT HOOK : Removal and Installation .....	15
SEAT BELT RETRACTOR : Inspection .....	8		

# PRECAUTIONS

< PRECAUTION >

## PRECAUTION

### PRECAUTIONS

#### Precaution for Technicians Using Medical Electric

INFOID:000000007071862

##### OPERATION PROHIBITION

###### **WARNING:**

- Parts with strong magnet is used in this vehicle.
- Technicians using a medical electric device such as pacemaker must never perform operation on the vehicle, as magnetic field can affect the device function by approaching to such parts.

##### NORMAL CHARGE PRECAUTION

###### **WARNING:**

- If a technician uses a medical electric device such as an implantable cardiac pacemaker or an implantable cardioverter defibrillator, the possible effects on the devices must be checked with the device manufacturer before starting the charge operation.
- As radiated electromagnetic wave generated by on board charger at normal charge operation may effect medical electric devices, a technician using a medical electric device such as implantable cardiac pacemaker or an implantable cardioverter defibrillator must not enter the vehicle compartment (including luggage room) during normal charge operation.

##### Precaution at telematics system operation

###### **WARNING:**

- If a technician uses implantable cardiac pacemaker or implantable cardioverter defibrillator (ICD), avoid the device implanted part from approaching within approximately 220 mm (8.66 in) from interior/exterior antenna.
- The electromagnetic wave of TCU might affect the function of the implantable cardiac pacemaker or the implantable cardioverter defibrillator (ICD), when using the service, etc.
- If a technician uses other medical electric devices than implantable cardiac pacemaker or implantable cardioverter defibrillator(ICD), the electromagnetic wave of TCU might affect the function of the device. The possible effects on the devices must be checked with the device manufacturer before TCU use.

##### Precaution at intelligent key system operation

###### **WARNING:**

- If a technician uses implantable cardiac pacemaker or implantable cardioverter defibrillator (ICD), avoid the device implanted part from approaching within approximately 220 mm (8.66 in) from interior/exterior antenna.
- The electromagnetic wave of intelligent key might affect the function of the implantable cardiac pacemaker or the implantable cardioverter defibrillator (ICD), at door operation, at each request switch operation, or at engine starting.
- If a technician uses other medical electric devices than implantable cardiac pacemaker or implantable cardioverter defibrillator (ICD), the electromagnetic wave of intelligent key might affect the function of the device. The possible effects on the devices must be checked with the device manufacturer before intelligent key use.

#### Point to Be Checked Before Starting Maintenance Work

INFOID:000000007079449

The high voltage system may starts automatically. It is required to check that the timer air conditioner and timer charge (during EVSE connection) are not set before starting maintenance work.

###### **NOTE:**

If the timer air conditioner or timer charge (during EVSE connection) is set, the high voltage system starts automatically even when the power switch is in OFF state.

#### Precaution for Supplemental Restraint System (SRS) "AIR BAG" and "SEAT BELT PRE-TENSIONER"

INFOID:000000006959171

The Supplemental Restraint System such as "AIR BAG" and "SEAT BELT PRE-TENSIONER", used along with a front seat belt, helps to reduce the risk or severity of injury to the driver and front passenger for certain types of collision. This system includes seat belt switch inputs and dual stage front air bag modules. The SRS

# PRECAUTIONS

## < PRECAUTION >

system uses the seat belt switches to determine the front air bag deployment, and may only deploy one front air bag, depending on the severity of a collision and whether the front occupants are belted or unbelted. Information necessary to service the system safely is included in the "SRS AIR BAG" and "SEAT BELT" of this Service Manual.

### **WARNING:**

Always observe the following items for preventing accidental activation.

- To avoid rendering the SRS inoperative, which could increase the risk of personal injury or death in the event of a collision that would result in air bag inflation, all maintenance must be performed by an authorized NISSAN/INFINITI dealer.
- Improper maintenance, including incorrect removal and installation of the SRS, can lead to personal injury caused by unintentional activation of the system. For removal of Spiral Cable and Air Bag Module, see "SRS AIR BAG".
- Never use electrical test equipment on any circuit related to the SRS unless instructed to in this Service Manual. SRS wiring harnesses can be identified by yellow and/or orange harnesses or harness connectors.

## PRECAUTIONS WHEN USING POWER TOOLS (AIR OR ELECTRIC) AND HAMMERS

### **WARNING:**

Always observe the following items for preventing accidental activation.

- When working near the Air Bag Diagnosis Sensor Unit or other Air Bag System sensors with the power switch ON, never use air or electric power tools or strike near the sensor(s) with a hammer. Heavy vibration could activate the sensor(s) and deploy the air bag(s), possibly causing serious injury.
- When using air or electric power tools or hammers, always switch the power switch OFF, disconnect the 12V battery, and wait at least 3 minutes before performing any service.

## Precaution for Seat Belt Service

INFOID:0000000006962092

### **CAUTION:**

- Before removing the front seat belt pre-tensioner assembly, push the power switch off, disconnect 12V battery negative terminal and wait at least 3 minutes.
- Do not use electrical test equipment for front seat belt pre-tensioner connector.
- After replacing or reinstalling front seat belt pre-tensioner assembly, or reconnecting front seat belt pre-tensioner connector, check the system function. Refer to [SRC-13, "Description"](#).
- Do not use disassembled buckle or seat belt assembly.
- Replace anchor bolts if they are deformed or worn out.
- Never oil tongue and buckle.
- If any component of seat belt assembly is questionable, do not repair. Replace the entire seat belt assembly.
- If webbing is cut, frayed or damaged, replace seat belt assembly.
- When replacing seat belt assembly, use a genuine NISSAN seat belt assembly.

## AFTER A COLLISION

### **WARNING:**

Inspect all seat belt assemblies including retractors and attached hardware after any collision.

NISSAN recommends that all seat belt assemblies in use during a collision be replaced unless the collision was minor and the belts show no damage and continue to operate properly. Failure to do so could result in serious personal injury in an accident. Seat belt assemblies not in use during a collision should also be replaced if either damage or improper operation is noted. Seat belt pre-tensioners should be replaced even if the seat belts are not in use during a frontal collision in which the air bags are deployed.

Replace any seat belt assembly (including anchor bolts) if:

- The seat belt was in use at the time of a collision (except for minor collisions and the belts, retractors and buckles show no damage and continue to operate properly).
- The seat belt was damaged in an accident (i.e. torn webbing, bent retractor or guide).
- The seat belt attaching point was damaged in an accident. Inspect the seat belt attaching area for damage or distortion and repair as necessary before installing a new seat belt assembly.
- Anchor bolts are deformed or worn out.
- The front seat belt pre-tensioner should be replaced even if the seat belts are not in use during the collision in which the air bags are deployed.

# FRONT SEAT BELT

< REMOVAL AND INSTALLATION >

## REMOVAL AND INSTALLATION

### FRONT SEAT BELT

Exploded View

INFOID:000000006959144

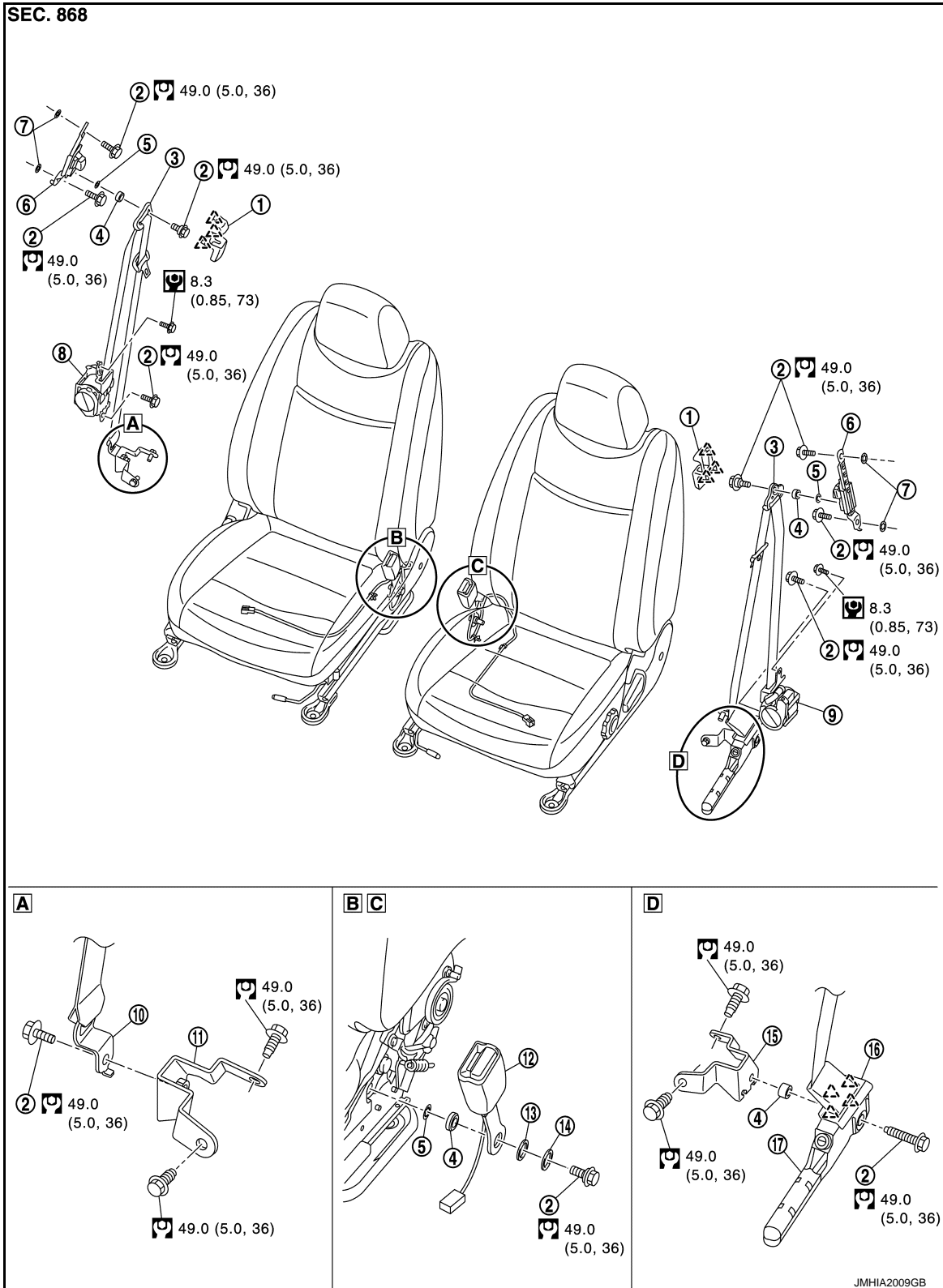



# FRONT SEAT BELT

## < REMOVAL AND INSTALLATION >

- |   |   |  |
|---|---|--|
| 1. Adjuster cover                       | 2. Anchor bolt  | 3. Shoulder anchor                                 |
| 4. Spacer                               | 5. Retaining washer                                   | 6. Seat belt adjuster                              |
| 7. Fiber washer                         | 8. Seat belt pre-tensioner retractor (Passenger side) | 9. Seat belt pre-tensioner retractor (Driver side) |
| 10. Outer anchor                        | 11. Joint bracket assembly RH                         | 12. Seat belt buckle                               |
| 13. Plastic washer                      | 14. Wave washer                                       | 15. Joint bracket assembly LH                      |
| 16. Lap pre-tensioner seat belt garnish | 17. Lap pre-tensioner                                 |  |

 : Pawl

 : N·m (kg-m, in-lb)

 : N·m (kg-m, ft-lb)

## SEAT BELT RETRACTOR

### SEAT BELT RETRACTOR : Removal and Installation

INFOID:000000006959145

#### REMOVAL

#### **WARNING:**

**Before servicing, push power switch OFF, disconnect 12V battery negative terminal and wait 3 minutes or more.**

Driver side

1. Remove shoulder anchor.
  1. Slide driver seat to the frontmost position.
  2. Pull adjuster cover in direction indicated by arrows as shown in the figure. Remove adjuster cover.

 : Pawl

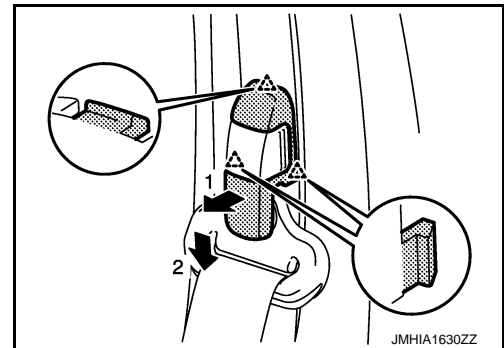

3. Remove shoulder anchor mounting anchor bolt.
2. Remove lap pre-tensioner.
  1. Remove front kicking plate inner and rear kicking plate inner. Refer to [INT-21, "KICKING PLATE INNER : Removal and Installation"](#).
  2. Remove center pillar lower garnish. Refer to [INT-23, "CENTER PILLAR LOWER GARNISH : Removal and Installation"](#).
  3. Remove driver seat from the vehicle. Refer to [SE-16, "Removal and Installation"](#).
- CAUTION:**  
When removing and installing, use shop cloths to protect parts from damage.
4. Lift up lap pre-tensioner seat belt garnish, disengage pawls, and remove lap pre-tensioner seat belt garnish.

 : Pawl

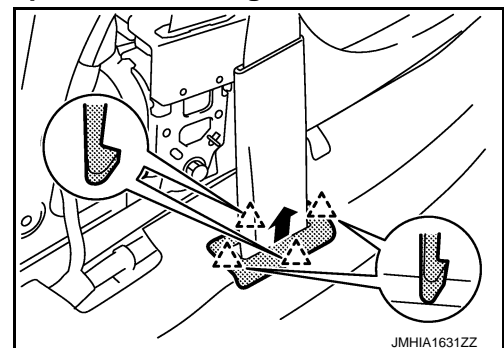

A  
B  
C  
D  
E  
F  
G  
SB  
I  
J  
K  
L  
M  
N  
O  
P

# FRONT SEAT BELT

## < REMOVAL AND INSTALLATION >

5. Pull up floor carpet.
6. Remove front floor spacer and rear floor spacer.
7. Disconnect lap pre-tensioner seat belt harness connector.

**CAUTION:**

- For installing/removing lap pre-tensioner connector, insert thin screwdriver wrapped in tape into notch, lift lock and remove connector.
- Install connector with lock raised, and push lock into connector.
- After installing the connector, check that the lock is pushed securely into it.

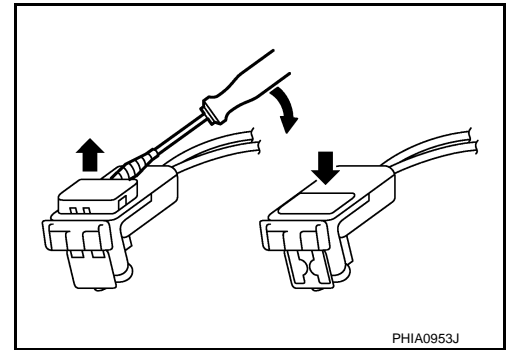

8. Remove joint bracket assembly LH mounting bolts (A).

← Vehicle front

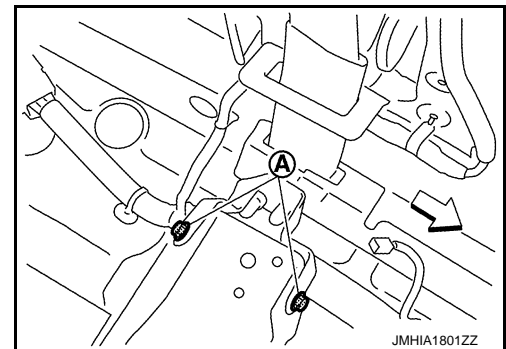

9. Remove mounting anchor bolt of lap pre-tensioner, and then remove lap pre-tensioner from joint bracket assembly LH.

3. Remove seat belt pre-tensioner retractor.

1. Remove seat belt pre-tensioner retractor mounting anchor bolt and screw.
2. Disconnect seat belt pre-tensioner harness connector.

**CAUTION:**

- For installing/removing seat belt pre-tensioner connector, insert thin screwdriver wrapped in tape into notch, lift lock and remove connector.
- Install connector with lock raised, and push lock into connector.
- After installing the connector, check that the lock is pushed securely into it.

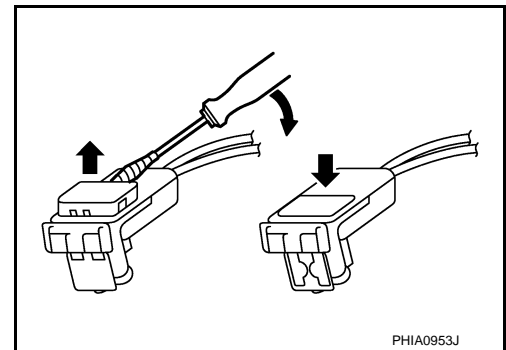

- Never place pre-tensioner seat belt in an area where the temperature reaches 80°C or more.

4. Remove seat belt adjuster.

1. Remove center pillar upper garnish.  
Refer to [INT-24. "CENTER PILLAR UPPER GARNISH : Removal and Installation"](#).
2. Remove seat belt adjuster mounting anchor bolts.

Passenger side

1. Remove shoulder anchor.
  1. Slide passenger seat to the frontmost position.

# FRONT SEAT BELT

## < REMOVAL AND INSTALLATION >

2. Pull adjuster cover in direction indicated by arrows as shown in the figure. Remove adjuster cover.

 : Pawl

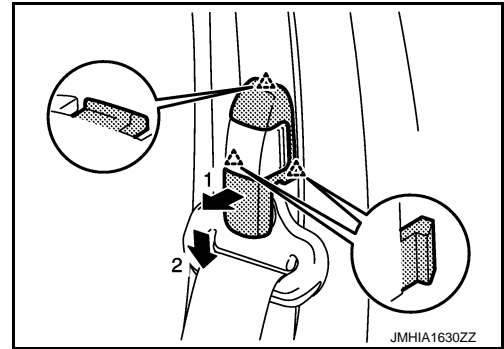

3. Remove shoulder anchor mounting anchor bolt.
2. Remove outer anchor.
  1. Remove front kicking plate inner and rear kicking plate inner. Refer to [INT-21, "KICKING PLATE INNER : Removal and Installation"](#).
  2. Remove center pillar lower garnish. Refer to [INT-23, "CENTER PILLAR LOWER GARNISH : Removal and Installation"](#).
  3. Remove driver seat from the vehicle. Refer to [SE-16, "Removal and Installation"](#).

**CAUTION:**

**When removing and installing, use shop cloths to protect parts from damage.**

4. Pull up floor carpet.
5. Remove front floor spacer and rear floor spacer.
6. Remove joint bracket assembly RH mounting bolts (A).

 Vehicle front

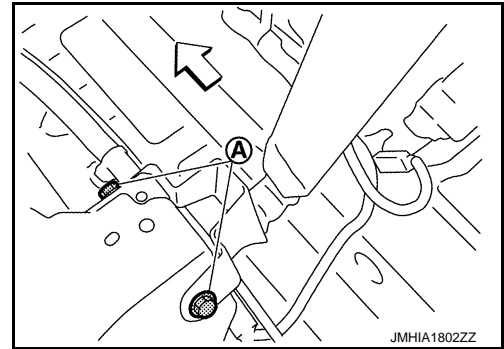

7. Remove mounting anchor bolt of outer anchor, and then remove outer anchor from joint bracket assembly RH.
3. Remove seat belt pre-tensioner retractor.
  1. Disconnect seat belt pre-tensioner harness connector.

**CAUTION:**

- For installing/removing seat belt pre-tensioner connector, insert thin screwdriver wrapped in tape into notch, lift lock and remove connector.
- Install connector with lock raised, and push lock into connector.
- After installing the connector, check that the lock is pushed securely into it.

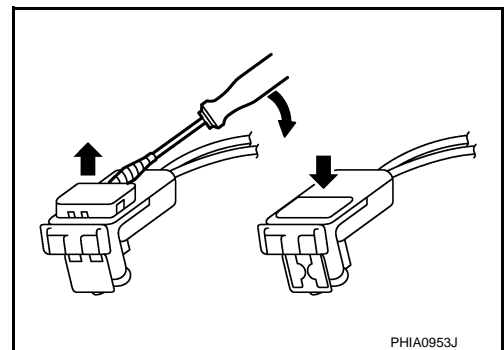

2. Remove seat belt pre-tensioner retractor mounting anchor bolt and screw.

**CAUTION:**  
**Never place pre-tensioner seat belt in an area where the temperature reaches 80°C or more.**
4. Remove seat belt adjuster.
  1. Remove center pillar upper garnish.

# FRONT SEAT BELT

## < REMOVAL AND INSTALLATION >

---

Refer to [INT-24. "CENTER PILLAR UPPER GARNISH : Removal and Installation"](#).

2. Remove seat belt adjuster mounting anchor bolts.

## INSTALLATION

Install in the reverse order of removal.

## SEAT BELT RETRACTOR : Inspection

INFOID:000000006959146

## AFTER A COLLISION

### **WARNING:**

**Inspect all seat belt assemblies including retractors and attached hardware after any collision. NISSAN/INFINITI recommends that all seat belt assemblies in use during a collision be replaced unless the collision was minor and the belts show no damage and continue to operate properly. Failure to do so could result in serious personal injury in an accident. Seat belt assemblies not in use during a collision should also be replaced if either damage or improper operation was noted. Seat belt pre-tensioners should be replaced even if the seat belts were not in use during a frontal collision in which the air bags were deployed.**

Replace any seat belt assembly (including anchor bolts) if:

- The seat belt is in use at the time of a collision (except for minor collisions and the belts, retractors and buckles show no damage and continue to operate properly).
- The seat belt is damaged in an accident (i.e. torn webbing, bent retractor or guide, etc.).
- The seat belt attaching point is damaged in an accident. Inspect the seat belt attaching area for damage or distortion and repair if necessary before installing a new seat belt assembly.
- Anchor bolts are deformed or worn out.
- The seat belt pre-tensioners must be replaced even if the seat belts were not in use during the collision in which the air bags were deployed.

## PRELIMINARY CHECKS

1. Check the seat belt warning lamp for proper operation as per the following:
  - a. Turn power switch ON. The seat belt warning lamp should illuminate.
  - b. Fasten driver seat belt. The seat belt warning lamp should turn OFF.
2. If the air bag warning lamp is blinking, perform self-diagnosis with CONSULT and air bag warning lamp. Refer to [SRC-13. "Description"](#).
3. Check that the seat belt retractor, seat belt anchor and buckle bolts are tightened firmly.
4. Check the shoulder seat belt guide and shoulder belt height adjuster for front seats. Check that guide swivels freely and that webbing lays flat and does not bind in guide. Check that height adjuster operates properly and holds securely.
5. Check retractor operation:
  - a. Fully extend the seat belt webbing and check for twists, tears or other damage.
  - b. Allow the seat belt to retract. Check that webbing returns smoothly and completely into the retractor. If the seat belt does not return smoothly, wipe the inside of the loops with a clean paper cloth. Dirt build-up in the loops of the upper anchors can cause the seat belts to retract slowly.
  - c. Fasten the seat belt. Check that seat belt returns smoothly and completely to the retractor. If the webbing does not return smoothly, the cause may be an accumulation of dust or dirt. Use the "SEAT BELT TAPE SET" and perform the following steps.

Inspect the front seat belt through-anchor

1. Pull the seat belt out to a length of 500 mm (19.69 in) or more.
  2. Fix the seat belt at the center pillar webbing opening with a clip or other device.
  3. Pass a thin wire through the through-anchor webbing opening. Hold both ends of the wire and pull it tightly while moving it up and down several times along the webbing opening surface to remove dirt stuck there.
  4. Any dirt that cannot be removed with the wire can be removed by cleaning the opening with a clean cloth.
  5. Apply tape at the point where the webbing contacts the through-anchor webbing opening.

**NOTE:**  
Apply the tape so that there is no slack or wrinkling.
  6. Remove the clip fixing the seat belt and check that the webbing returns smoothly.
6. Repeat steps above if necessary to check the other seat belts.



# FRONT SEAT BELT

## < REMOVAL AND INSTALLATION >

### SEAT BELT RETRACTOR ON-VEHICLE CHECK

Emergency Locking Retractors (ELR) and Automatic Locking Retractors (ALR)

#### NOTE:

All seat belt retractors are Emergency Locking Retractors (ELR) type. In an emergency (sudden stop) the retractor will lock and prevent the webbing from extending any further. All 3-point type seat belt retractors except the driver seat belt also have an Automatic Locking Retractors (ALR) mode. The ALR mode (also called child restraint mode) is used when installing child seats. The ALR mode is activated when the seat belt is fully extended. When the webbing is then retracted partially, the ALR mode automatically locks the seat belt in a specific position so the webbing cannot be extended any further. To cancel the ALR mode, allow the seat belt to fully wind back into the retractor.

Check the seat belt retractors with the following test(s) to determine if a retractor assembly is operating properly.

#### ELR Function Stationary Check

Grasp the shoulder webbing and pull forward quickly. The retractor should lock and prevent the belt from extending further.

#### ALR Function Stationary Check

1. Pull out the entire length of seat belt from retractor until a click is heard.
2. Retract the webbing partially. A clicking noise should be heard as the webbing retracts indicating that the retractor is in the Automatic Locking Retractors (ALR) mode.
3. Grasp the seat belt and try to pull out the retractor. The webbing must lock and not extend any further. If it does not operate normally, replace the retractor assembly.
4. Allow the entire length of the webbing to retract to cancel the automatic locking mode.

#### ELR Function Moving Check

#### WARNING:

Perform the following test in a safe, open area clear of other vehicles and obstructions (for example, a large, empty parking lot). Road surface must be paved and dry. Never perform the following test on wet or gravel roads or on public streets and highways. This could result in an accident and serious personal injury. The driver and passenger must be prepared to brace themselves in the event that the retractor does not lock.

1. Fasten driver seat belt. Buckle a passenger into the seat for the belt that is to be tested.
2. Proceed to the designated safe area.
3. Drive the vehicle at approximately 16 km/h (10 MPH). Notify any passengers of a pending sudden stop and the driver and passenger must be prepared to brace themselves in the event that the retractor does not lock. Apply brakes firmly and make a very hard stop.

During stopping, seat belts should lock and not be extended. If the seat belt retractor assembly does not lock, perform the retractor off-vehicle check.

### SEAT BELT RETRACTOR OFF-VEHICLE CHECK

1. Remove the front seat belt retractor. Refer to [SB-5, "SEAT BELT RETRACTOR : Removal and Installation"](#).
2. Slowly pull out webbing while tilting the retractor assembly forward from the mounted position without twisting the retractor assembly as shown in the figure.
  - The webbing can be pulled out when the angle (A) is 10 degrees or less.
  - The webbing cannot be pulled out when the angle (B) is 30 degrees or more.

A and B : Tilting angles

← : Vehicle front

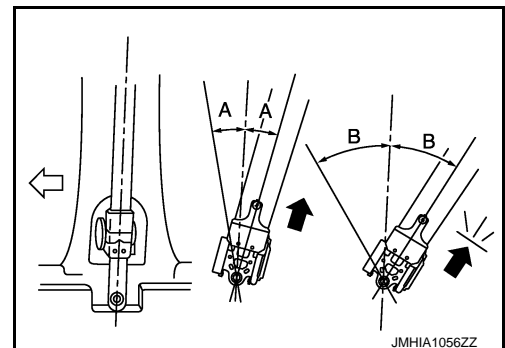

3. Replace the seat belt assembly if it does not operate normally.

# FRONT SEAT BELT

< REMOVAL AND INSTALLATION >

---

## SEAT BELT BUCKLE

### SEAT BELT BUCKLE : Removal and Installation

INFOID:000000006959147

#### REMOVAL

##### **WARNING:**

**Before servicing, push power switch OFF, disconnect 12V battery negative terminal and wait 3 minutes or more.**

1. Remove front seat from the vehicle.  
Refer to [SE-16, "Removal and Installation"](#).

##### **CAUTION:**

**When removing and installing, use shop cloths to protect parts from damage.**

2. Remove harness fixing clamps of seat belt buckle and connector fixing clip that are installed on seat.
3. Remove seat cushion inner finisher. Refer to [SE-20, "SEAT CUSHION : Disassembly and Assembly"](#).
4. Remove seatback trim and seatback pad. Refer to [SE-17, "SEATBACK : Disassembly and Assembly"](#).
5. Remove seat belt buckle mounting anchor bolt, and then remove seat belt buckle from seat.

#### INSTALLATION

Install in the reverse order of removal.

### SEAT BELT BUCKLE : Inspection

INFOID:000000006959148

#### AFTER A COLLISION

##### **WARNING:**

**Inspect all seat belt assemblies including retractors and attached hardware after any collision. NISSAN/INFINITI recommends that all seat belt assemblies in use during a collision be replaced unless the collision was minor and the belts show no damage and continue to operate properly. Failure to do so could result in serious personal injury in an accident. Seat belt assemblies not in use during a collision should also be replaced if either damage or improper operation was noted. Seat belt pre-tensioners should be replaced even if the seat belts were not in use during a frontal collision in which the air bags were deployed.**

Replace any seat belt assembly (including anchor bolts) if:

- The seat belt is in use at the time of a collision (except for minor collisions and the belts, retractors and buckles show no damage and continue to operate properly).
- The seat belt is damaged in an accident (i.e. torn webbing, bent retractor or guide, etc.).
- The seat belt attaching point is damaged in an accident. Inspect the seat belt attaching area for damage or distortion and repair if necessary before installing a new seat belt assembly.
- Anchor bolts are deformed or worn out.
- The seat belt pre-tensioner must be replaced even if the seat belts were not in use during the collision in which the air bags were deployed.

#### PRELIMINARY CHECKS

1. Check the seat belt warning lamp for proper operation as per the following:
  - a. Turn power switch ON. The seat belt warning lamp should illuminate.
  - b. Fasten driver seat belt. The seat belt warning lamp should turn OFF.
2. If the air bag warning lamp is blinking, perform self-diagnosis using CONSULT and air bag warning lamp. Refer to [SRC-13, "Description"](#).
3. Check that the seat belt retractor, seat belt anchor and buckle bolts are tightened firmly.
4. Repeat steps above if necessary to check the other seat belts.

# REAR SEAT BELT

< REMOVAL AND INSTALLATION >

## REAR SEAT BELT

Exploded View

INFOID:000000006959149

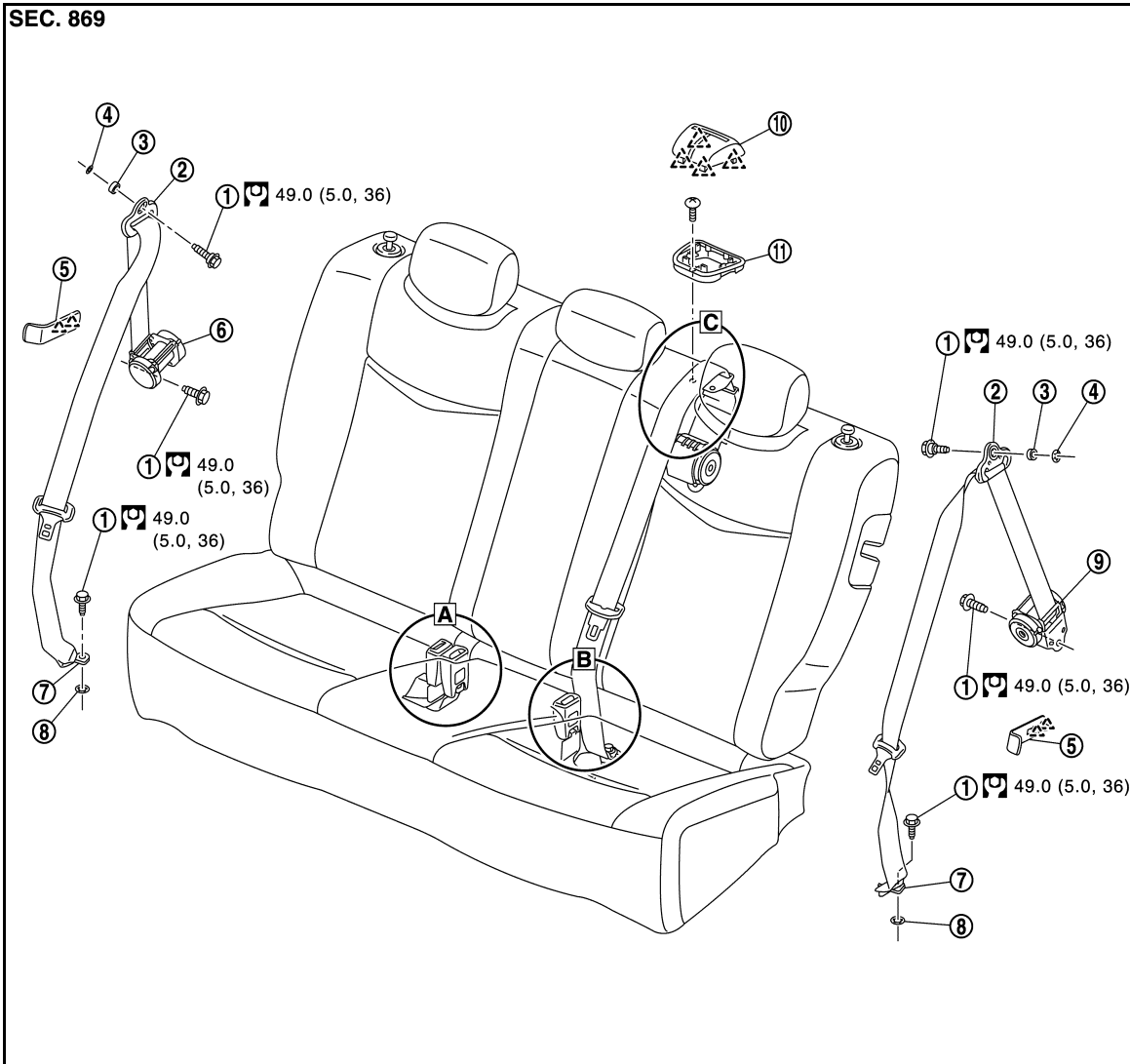

A  
B  
C  
D  
E  
F  
G  
SB  
I  
J  
K  
L  
M  
N  
O  
P

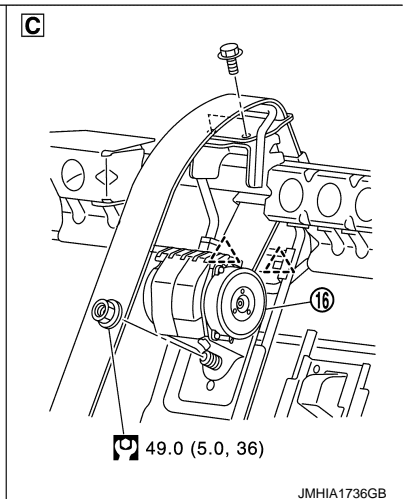
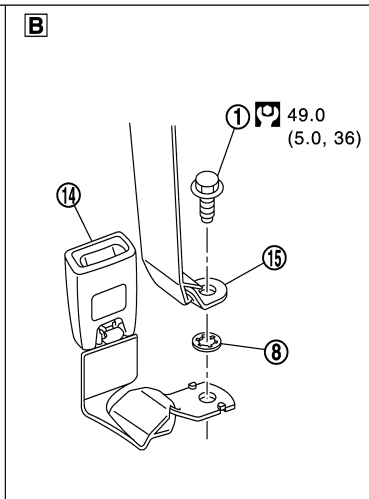
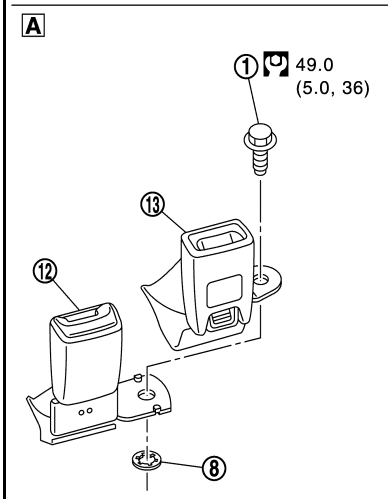

JMHIA1736GB

- |                     |                     |                                 |
|---------------------|---------------------|---------------------------------|
| 1. Anchor bolt      | 2. Shoulder anchor  | 3. Space                        |
| 4. Retaining washer | 5. Seat belt hook   | 6. Outer seat belt retractor RH |
| 7. Outer anchor     | 8. Retaining washer | 9. Outer seat belt retractor LH |

# REAR SEAT BELT

## < REMOVAL AND INSTALLATION >

- |                                |                               |                         |
|--------------------------------|-------------------------------|-------------------------|
| 10. Center seat belt cover     | 11. Center seat belt finisher | 12. Seat belt buckle RH |
| 13. Center seat belt buckle    | 14. Seat belt buckle LH       | 15. Center anchor       |
| 16. Center seat belt retractor |                               |                         |

 : Pawl

 : N·m (kg-m, ft-lb)

## SEAT BELT RETRACTOR

### SEAT BELT RETRACTOR : Removal and Installation

INFOID:000000006959150

#### REMOVAL

##### Outer seat belt retractor

1. Remove outer anchor.
  1. Remove rear seat cushion from the vehicle.  
Refer to [SE-23, "SEAT CUSHION : Removal and Installation"](#).
  2. Remove outer anchor mounting anchor bolt.
2. Remove shoulder anchor.
  1. Remove rear seatback from the vehicle.  
Refer to [SE-24, "SEATBACK : Removal and Installation"](#).
  2. Remove luggage side lower finisher.  
Refer to [INT-35, "LUGGAGE SIDE LOWER FINISHER : Removal and Installation"](#).
  3. Remove luggage floor upper finisher.  
Refer to [INT-34, "LUGGAGE FLOOR FRONT FINISHER : Removal and Installation"](#).
  4. Remove shoulder anchor mounting anchor bolt.
3. Remove outer seat belt retractor mounting anchor bolt, and then remove outer seat belt retractor.

##### Center seat belt retractor

1. Remove center anchor.
  1. Remove rear seat cushion from the vehicle.  
Refer to [SE-23, "SEAT CUSHION : Removal and Installation"](#).
  2. Remove center anchor mounting anchor bolt.
2. Remove rear seatback LH from the vehicle.  
Refer to [SE-24, "SEATBACK : Removal and Installation"](#).
3. Remove seatback trim and seatback pad from seatback frame.  
Refer to [SE-24, "SEATBACK : Disassembly and Assembly"](#).
4. Remove seatback silencer from seatback frame.
5. Remove center seat belt retractor.

# REAR SEAT BELT

## < REMOVAL AND INSTALLATION >

1. Remove mounting bolts (A) of upper webbing guide (1). Remove upper webbing guide from seatback frame.
2. Disengage pawls of lower webbing guide (2). Remove lower webbing guide in direction indicated by arrow as shown in the figure.
3. Remove mounting anchor nut (B) of center seat belt retractor (3) from seatback frame.

 : Pawl

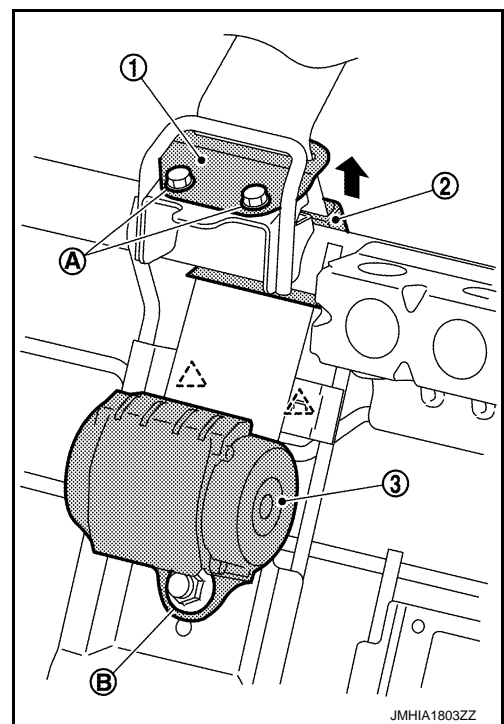

## INATALLATION

Install in the reverse order of removal.

## SEAT BELT RETRACTOR : Inspection

INFOID:000000006959151

## AFTER A COLLISION

### **WARNING:**

**Inspect all seat belt assemblies including retractors and attached hardware after any collision. NISSAN/INFINITI recommends that all seat belt assemblies in use during a collision be replaced unless the collision was minor and the belts show no damage and continue to operate properly. Failure to do so could result in serious personal injury in an accident. Seat belt assemblies not in use during a collision should also be replaced if either damage or improper operation was noted. Seat belt pre-tensioners should be replaced even if the seat belts were not in use during a frontal collision in which the air bags were deployed.**

Replace any seat belt assembly (including anchor bolts) if:

- The seat belt is in use at the time of a collision (except for minor collisions and the belts, retractors and buckles show no damage and continue to operate properly).
- The seat belt is damaged in an accident (i.e. torn webbing, bent retractor or guide, etc.).
- The seat belt attaching point is damaged in an accident. Inspect the seat belt attaching area for damage or distortion and repair if necessary before installing a new seat belt assembly.
- Anchor bolts are deformed or worn out.
- The seat belt pre-tensioners must be replaced even if the seat belts were not in use during the collision in which the air bags were deployed.

## PRELIMINARY CHECKS

1. Check that the seat belt retractor, seat belt anchor and buckle bolts are tightened firmly.
2. Check retractor operation:
  - a. Fully extend the seat belt webbing and check for twists, tears or other damage.
  - b. Allow the seat belt to retract. Check that webbing returns smoothly and completely into the retractor. If the seat belt does not return smoothly, wipe the inside of the loops with a clean paper cloth. Dirt build-up in the loops of that upper anchors can cause the seat belts to retract slowly.
  - c. Fasten the seat belt. Check that seat belt returns smoothly and completely to the retractor. If the webbing does not return smoothly, the cause may be an accumulation of dust or dirt. Use the "SEAT BELT TAPE SET" and perform the following steps.
3. Repeat steps above if necessary to check the other seat belts.

# REAR SEAT BELT

## < REMOVAL AND INSTALLATION >

### SEAT BELT RETRACTOR ON-VEHICLE CHECK

Emergency Locking Retractors (ELR) and Automatic Locking Retractors (ALR)

**NOTE:**

All seat belt retractors are Emergency Locking Retractors (ELR) type. In an emergency (sudden stop) the retractor will lock and prevent the webbing from extending any further. All 3-point type seat belt retractors except the driver seat belt also have an Automatic Locking Retractors (ALR) mode. The ALR mode (also called child restraint mode) is used when installing child seats. The ALR mode is activated when the seat belt is fully extended. When the webbing is then retracted partially, the ALR mode automatically locks the seat belt in a specific position so the webbing cannot be extended any further. To cancel the ALR mode, allow the seat belt to fully wind back into the retractor.

Check the seat belt retractors with the following test(s) to determine if a retractor assembly is operating properly.

#### ELR Function Stationary Check

Grasp the shoulder webbing and pull forward quickly. The retractor should lock and prevent the belt from extending further.

#### ALR Function Stationary Check

1. Pull out the entire length of seat belt from retractor until a click is heard.
2. Retract the webbing partially. A clicking noise should be heard as the webbing retracts indicating that the retractor is in the Automatic Locking Retractors (ALR) mode.
3. Grasp the seat belt and try to pull out the retractor. The webbing must lock and not extend any further. If it does not operate normally, replace the retractor assembly.
4. Allow the entire length of the webbing to retract to cancel the automatic locking mode.

#### ELR Function Moving Check

**WARNING:**

**Perform the following test in a safe, open area clear of other vehicles and obstructions (for example, a large, empty parking lot). Road surface must be paved and dry. Never perform the following test on wet or gravel roads or on public streets and highways. This could result in an accident and serious personal injury. The driver and passenger must be prepared to brace themselves in the event that the retractor does not lock.**

1. Fasten driver seat belt. Buckle a passenger into the seat for the belt that is to be tested.
2. Proceed to the designated safe area.
3. Drive the vehicle at approximately 16 km/h (10 MPH). Notify any passengers of a pending sudden stop and the driver and passenger must be prepared to brace themselves in the event that the retractor does not lock. Apply brakes firmly and make a very hard stop.

During stopping, seat belts should lock and not be extended. If the seat belt retractor assembly does not lock, perform the retractor off-vehicle check.

### SEAT BELT RETRACTOR OFF-VEHICLE CHECK

1. Remove the rear seat belt retractor. Refer to [SB-12, "SEAT BELT RETRACTOR : Removal and Installation"](#).
2. Slowly pull out webbing while tilting the retractor assembly forward from the mounted position without twisting the retractor assembly as shown in the figure.
  - a. Outer seat belt retractor
    - The webbing can be pulled out when the angle (A) is 17 degrees or less.
    - The webbing cannot be pulled out when the angle (B) is 37 degrees or more.

A and B : Tilting angles

← : Vehicle front

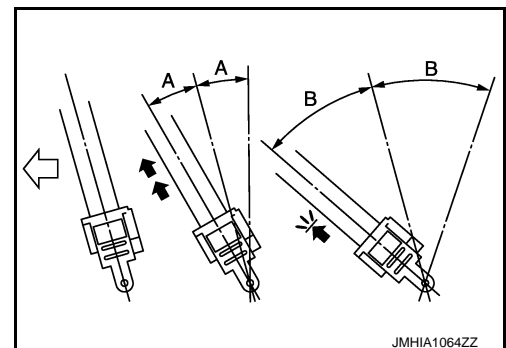

# REAR SEAT BELT

## < REMOVAL AND INSTALLATION >

### b. Center seat belt retractor

- The webbing can be pulled out when the angle (A) is 25 degrees or less.
- The webbing cannot be pulled out when the angle (B) is 45 degrees or more.

A and B : Tilting angles

← : Vehicle front

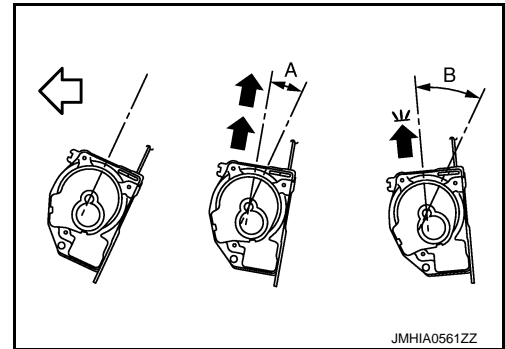

3. Replace the seat belt assembly if it does not operate normally.

## SEAT BELT BUCKLE

### SEAT BELT BUCKLE : Removal and Installation

INFOID:000000006959152

#### REMOVAL

1. Remove rear seat cushion from the vehicle.  
Refer to [SE-23, "SEAT CUSHION : Removal and Installation"](#).
2. Remove seat belt buckle mounting anchor bolt, and then remove seat belt buckle.

#### INSTALLATION

Install in the reverse order of removal.

### SEAT BELT BUCKLE : Inspection

INFOID:000000006959153

#### AFTER A COLLISION

##### **WARNING:**

**Inspect all seat belt assemblies including retractors and attached hardware after any collision. NISSAN/INFINITI recommends that all seat belt assemblies in use during a collision be replaced unless the collision was minor and the belts show no damage and continue to operate properly. Failure to do so could result in serious personal injury in an accident. Seat belt assemblies not in use during a collision should also be replaced if either damage or improper operation was noted. Seat belt pre-tensioners should be replaced even if the seat belts were not in use during a frontal collision in which the air bags were deployed.**

Replace any seat belt assembly (including anchor bolts) if:

- The seat belt is in use at the time of a collision (except for minor collisions and the belts, retractors and buckles show no damage and continue to operate properly).
- The seat belt is damaged in an accident. (i.e. torn webbing, bent retractor or guide, etc.)
- The seat belt attaching point is damaged in an accident. Inspect the seat belt attaching area for damage or distortion and repair if necessary before installing a new seat belt assembly.
- Anchor bolts are deformed or worn out.
- The seat belt pre-tensioner must be replaced even if the seat belts were not in use during the collision in which the air bags are deployed.

#### PRELIMINARY CHECKS

1. Check that the seat belt retractor, seat belt anchor and buckle bolts are tightened firmly.
2. Repeat step above if necessary to check the other seat belts.

## SEAT BELT HOOK

### SEAT BELT HOOK : Removal and Installation

INFOID:000000006959154

#### REMOVAL

1. Remove rear seatback from the vehicle.  
Refer to [SE-24, "SEATBACK : Removal and Installation"](#).

## REAR SEAT BELT

### < REMOVAL AND INSTALLATION >

---

2. Remove rear seat cushion from the vehicle.  
Refer to [SE-23, "SEAT CUSHION : Removal and Installation"](#).
3. Remove luggage side lower finisher.  
Refer to [INT-35, "LUGGAGE SIDE LOWER FINISHER : Removal and Installation"](#).
4. From back of luggage side lower finisher, press pawls indicated by arrows as shown in the figure and remove seat belt hook from luggage side lower finisher.

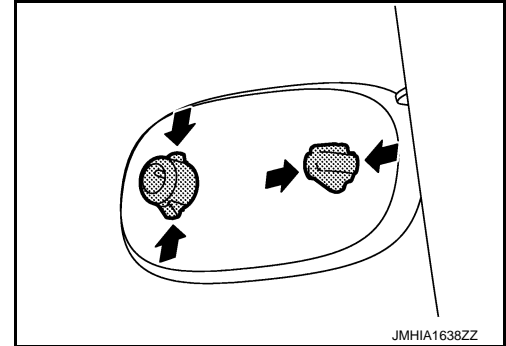

### INSTALLATION

Install in the reverse order of removal.