

Air Conditioning

Tech Tips

The following tech tips apply to specific symptoms or conditions on Subaru air conditioning systems. While these tech tips won't provide you with all the answers for Subaru air conditioning troubleshooting, they just might save you some time. Scan these pages to see if the symptoms on your problem vehicle match the descriptions here. As always, follow the recommended service procedures for all air conditioning repairs.

A/C Compressor Disengagement

A customer may complain of compressor disengagement after turning the system ON. If everything appears to be functioning correctly, don't forget to check the evaporator thermoprobe/thermoswitch. The evaporator thermoprobe is mounted in the fins of the evaporator and monitors evaporator temperature to keep the evaporator from freezing up. It does this by cycling the compressor clutch ON and OFF as necessary. If the thermoprobe fails, it will most likely allow the compressor clutch to engage initially, then open the compressor clutch circuit. The compressor then remains OFF and the A/C system produces poor cooling.

The compressor clutch can be re-engaged by turning the main dashboard A/C switch OFF, then ON again. However, the thermoprobe will once again open the clutch circuit and will not re-close to engage the compressor clutch.

Checking the thermoprobe is easy. Locate the connector for the thermoprobe under the dash near the glove box and disconnect it. Now jumper across the harness side of the connector. Refer to the correct service manual for the vehicle you are working on to determine which

wires need to be jumpered. If the compressor now engages and stays engaged, you have more than likely found the cause of the problem.

Of course there are other system components that can cause a similar problem, but this is an easy check to perform. In most cases it is the source of the problem.

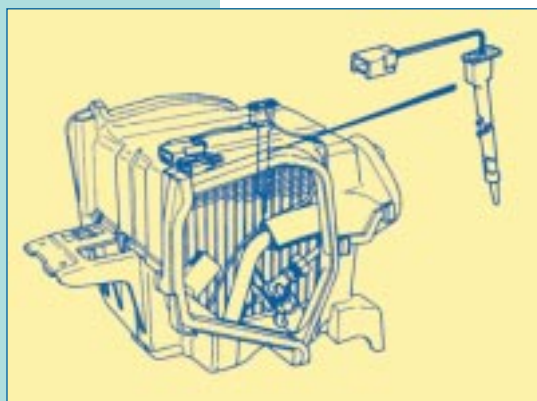

Dash Vent Mist

If a customer complains of mist coming from the A/C vents when the air conditioning system is operating, it is more than likely a normal condition caused by a number of factors. The evaporator is probably operating close to or at the freezing point. There may even be a small amount of ice accumulation on the evaporator, but not enough to affect system operation. The outside air is probably very humid, perhaps 85-95 percent relative humidity. When this very moist air comes in contact with the cold evaporator, it causes the moisture in the air to condense into a mist. You have probably observed

a similar situation when you opened the freezer on the refrigerator at home. This mist is then pushed by the fan, through the vehicle's ducts, and into the passenger compartment.

We can't change the weather conditions, but a very minor adjustment to the vehicle's air conditioning system will correct the problem. Move the temperature lever on the control panel slightly toward the warm position. This blends a little of the warm air from the heater core with the outside air to melt the coating of ice on the evaporator. Vehicle cooling will not be noticeably affected by this small movement of the temperature lever. The customer will have to experiment to find the position that cures the condition, as it may change based on the weather conditions mentioned above.

So if you have checked out the system and can find nothing wrong, the weather conditions may be to blame. Spend a few minutes explaining this to the customer. Vehicles in areas with low humidity are unlikely to exhibit these symptoms.

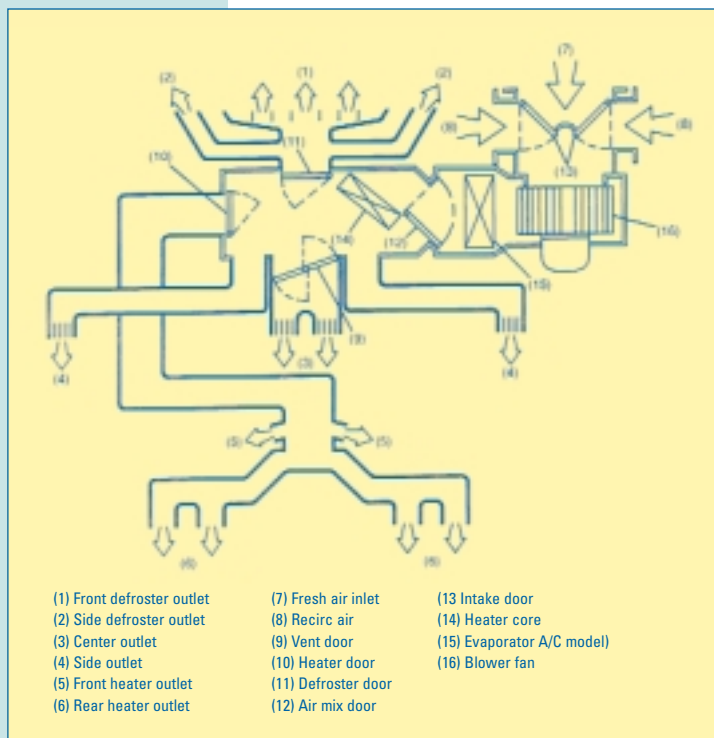

A/C Service Oil Adjustment

Should an A/C compressor or other component require replacement, it's important to adhere to the oil charge table listed in the service manual. Each component retains a certain amount of oil when removed. During replacement, this amount of oil must be compensated for. For example, if the condenser is replaced in a Calsonic-equipped 1991 Legacy, 2.9 fluid ounces must be added to the system to compensate for the estimated amount of oil that will be taken out of the system when the original condenser is removed. On the other hand, since replacement compressors come with a full oil charge for the whole system, oil must actually be *removed* from the compressor to avoid overcharging the system with oil. Overcharging the systems with oil will result in reduced cooling effectiveness, while undercharging will result in increased system wear and possible failure.

Subaru recommends the use of a refrigerant recycling machine to protect the environment.

SVX Zexel Auto A/C

Use only D-90PX refrigerant oil when repairing the SVX Zexel Auto A/C system. This oil is available through the normal Subaru parts channels, using part number 73019AA100 for an 8 fluid ounce container. The SVX Zexel variable displacement compressor DCW-17BE has a 5 fluid ounce capacity.

Note: Always keep a tight lid on refrigerant oils. All refrigerant oils are hygroscopic, which means they absorb moisture from the air. Moisture contaminated oil can cause system leakage failures later. Uncontaminated D-90PX is nearly clear and colorless. If it appears to be tinted brownish-yellow or has a brown-colored substance floating at the bottom of the container, discard it and order a new supply.

Use Of A/C Refrigerants Other Than R-12

Unless it has been retrofitted to R-134a, do not use any refrigerant other than R-12 in Subaru air conditioning systems that were originally charged with R-12. Various 'alternative,' 'replacement' or 'drop-in' refrigerants are available in the marketplace for use in R-12 air conditioning systems. Subaru and the manufacturers of its air conditioning systems do not recommend the use of any of these refrigerants. Continue to use R-12, or retrofit the system to R-134a.

Refrigerant Cross Contamination

All 1996 and later Subaru models are equipped with R-134a refrigerant air conditioning systems. Some models were equipped with this type of system as early as 1994. R-134a does not contain suspected ozone-depleting chlorofluorocarbons. The chemical compounds and molecular structures of R-12 and R-134a are completely different. However, the temperature/pressure relationships of the two are very similar. R-134a and R-12 are not compatible. Under no circumstances should they be mixed.

If you suspect that a refrigerant system has been tampered with or may be contaminated, observe the following general rules.

Symptoms of a contaminated refrigerant system may be any of the following:

- High system pressure (could be extreme). The higher the mix of contamination, the higher the pressure will be.
- Poor cooling.
- Rapid cycling of the compressor.

Inspect for:

- Correct condenser fan operation,
- Debris in front of the condenser,
- Correct blower fan operation,
- Charge/caution label,
- Service ports, stripped threads (from wrong fittings),
- Cloudy, milky sight glass.

Contact customer for:

- Repair history,
- Previous dealer or independent shop repair.

Refrigerants must be handled properly. Always wear protective gloves and goggles. For your safety and the safety of others, it is imperative that the work area be properly ventilated. If a refrigerant release occurs, wait until the mist clears before continuing. R-12 and R-134a must be handled separately. The two refrigerants cannot be mixed. The lubricating oils used in the R-12 and R-134a systems are incompatible. Service tools cannot be intermixed. If you find yourself unsure of what to do when servicing an R-134a system, don't guess. Refer to service manuals and service bulletins. As with all automotive repair work, good service depends on good diagnosis.

A/C Diagnostic Aids

Here are a couple of tips to assist you when diagnosing Subaru A/C systems. Although confirmed and directed at Legacy vehicles using Zexel's optional A/C systems with a variable displacement compressor, the diagnostics should apply to Calsonic systems as well. Keep in mind, there are no absolute pressure readings when using a manifold gauge set, due to temperature, humidity and load variations. Instead, key on what could be considered an acceptable range, as well as the relationship between the high and low gauge readings.

Compressor Failure

If the compressor is fixed at minimum displacement, look for a much smaller than usual difference between the low side and high side pressures. In other words, the low side may appear slightly higher than normal and the high side slightly lower, as the two system sides move towards equalization. Manifold gauge readings of 50 (low side) and 75 (high side) are representative of this condition.



Expansion Valve Failure—Excessive Restriction

Your manifold gauge readings will show the low side almost normal or slightly below normal and your high side will definitely be lower than normal. Reading of 28 (low side) and 90 (high side) are representative of this condition. In addition, if the expansion valve is clogged, stuck closed or inoperative, the expansion valve inlet area will exhibit heavy sweating or frosting. There will be a slight decrease in cooling performance that will increase as the condition worsens.

A low side reading of 25-35 is not necessarily abnormal. The high side reading must always be considered along with the low/high side relationship.

A/C Pulser System Diagnosis

Several early Subaru A/C systems were equipped with a 'pulse sensor' system. This system was designed to protect the A/C drive belt if the A/C compressor began to lock up. The system compares engine RPM with A/C compressor RPM. If A/C compressor RPM drops below engine RPM, the system assumes the compressor is beginning to fail. To spare the belt, the compressor clutch is disengaged.

This information is intended specifically for 1989-90 Loyale models equipped with either Hitachi or Panasonic A/C systems. However, the information may also be applied to other models and model years using a pulse sensor system.

Upon engine start-up, the A/C is turned on and the clutch engages and runs for several seconds, only to shut off by itself. The clutch may also disengage and stop the compressor from running if the engine is revved slightly right after engine start-up.

If the A/C drive belt condition and tension have been confirmed as good (important), suspect the A/C pulser system and follow the checks outlined below:

- Start the engine and engage the A/C system.
- Find the A/C relay located under the hood on the RH (passenger side) of the firewall.
- Ground the red wire with black tracer or the red wire with green tracer on turbo models, using a wire or test light.
- If the compressor comes on and stays on, the pulser system is probably at fault.

The pulser system components to check are listed below. Refer to the information contained in the appropriate service manual for specific checking details:

- Compressor pickup sensor,
- Evaporator thermostat,
- Loose wires on ignition coil,
- Pulse amplifier,
- Mode panel assembly (provides a ground to the evaporator thermostat).

Remember, the function of the pulser system is to compare engine speed to compressor speed and shut off the A/C compressor clutch if the amount of difference exceeds 20-25 percent and falls within the lock detection range.

Air Conditioning Evaporator Odor

As outdoor temperatures rise, so do the complaints of evaporator musty odor. To help control the amount of bacterial growth within the evaporator case (which causes the odor), perform the following:

- Check the evaporator drain hose for kinks or clogs which might restrict proper condensation or water drainage. Also, make sure the firewall outlet end of the drain hose is routed away from the catalytic converter.
- As a suggestion, try using the 'Max A/C' or 'Recirculation' mode for initial cool-down only. Then switch to the 'Normal A/C' mode. This allows outside air to enter the evaporator. Changing the mode positions to selections other than 'Max A/C' may reduce the conditions in which the bacteria grows.

- When the vehicle is parked, the duct system will remain in the last position programmed by the Mode control. Using a selection other 'Max A/C' can also help reduce the odor-causing environment.
- For chronic customer complaints, an evaporator cleaning agent can be used. Repair records indicate that evaporator removal for core cleaning is not necessary. Cleaning the evaporator through the fresh air duct is just as effective.

Compressor Failure Precautions

Always examine the oil when replacing a failed (seized or not pumping) A/C compressor. If you find metal particles, flush the entire with an approved air conditioning system flushing agent to remove the particles. Simply installing a new receiver-drier with the replacement compressor may not be enough to keep the leftover particles from clogging the expansion valve and possibly the bellows valve in the compressor.

If compressed air is used to dry the system after the flushing agent has been used, the system must be evacuated for an extended period of time to remove any residual moisture. A 30 minutes evacuation period is necessary for a new system that has not been opened to the atmosphere. Air conditioning manufacturers are recommending alternative system flushing procedures to comply with the Montreal protocol.

Zexel Air Conditioning Symptoms

Do not replace the compressor for customer complaints of a slight 'chirp' or squeak' when the compressor is engaged or during A/C cycling on Legacy Zexel A/C systems. Verify proper belt tension and A/C operation using the applicable service manual. If the A/C system is not used for a period of time,

the compressor and clutch assembly may require a break-in procedure to be performed. This procedure can be found in Service Bulletin 10-57-90, titled A/C Compressor Inspections.

As the customer uses the A/C or Defrost modes, the chirp or squeak will diminish. Also, the red clutch dust (a rust-like substance) is normal and will accumulate during normal usage. Do not replace the compressor or clutch for these conditions.

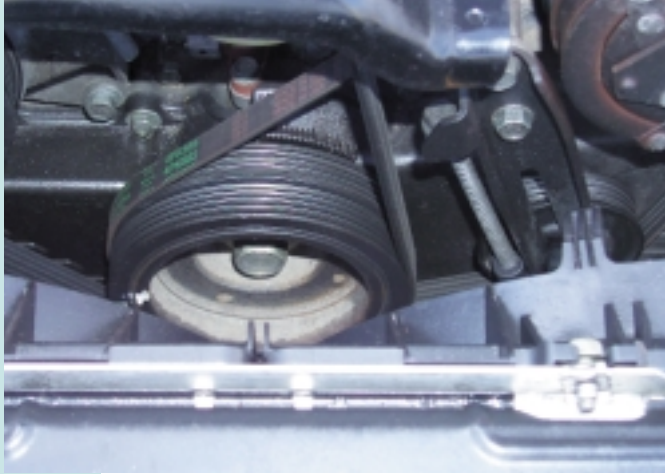

Compressor Belt Tension

When installing a new air conditioning belt, use a belt tension gauge approved for use with serpentine-type belts. Calsonic recommends 144-166 lbs. for a new belt. Zexel recommends 145-165 lbs. for a new belt.

Inoperative 1993 Impreza Air Conditioning

After verifying that the system has an adequate refrigerant charge using a manifold gauge set, try jumping the compressor to engage it. If the compressor still won't engage,

check the mode control panel. If an open circuit is found, the problem may be a poor connection at connector F-33 to I-6.

Inoperative Factory Installed Loyale Air Conditioning

A partially unplugged connector F66 (a black 21 pin connector located behind the fuse box) may keep the air conditioning from operating on factory installed Loyale A/C systems. This connector includes the wiring for the pulser system and various A/C components, including the mode switch. Always check the A/C basics: fuses, connectors and pressures.

