

SERVICE BULLETIN

APPLICABILITY

ALL LEGACY'S STARTING WITH ENGINE #338575
AND SHORT BLOCK #765733 EXCEPT RHD/POSTAL
VEHICLES

DATE

03-29-91

SUBJECT:

LEGACY ENGINE BLOCK MODIFICATION/
A/C COMPRESSOR BRACKET MOUNTING BOLT CHANGE

The Legacy engine block has undergone a change which decreased the A/C bracket bolt hole depth by 2mm. Shorter mounting bolts or spacer kits will be required when using A/C Kits P/N G3010AA000 and P/N G3010AA010 on production engines after Engine #338575 and after Engine #765733.

NOTE: When installing a modified engine block in an A/C equipped vehicle, a spacer kit or shorter mounting bolts must be used.

Spacer kits will be available separately through normal Parts channels by ordering P/N G3010AA020.

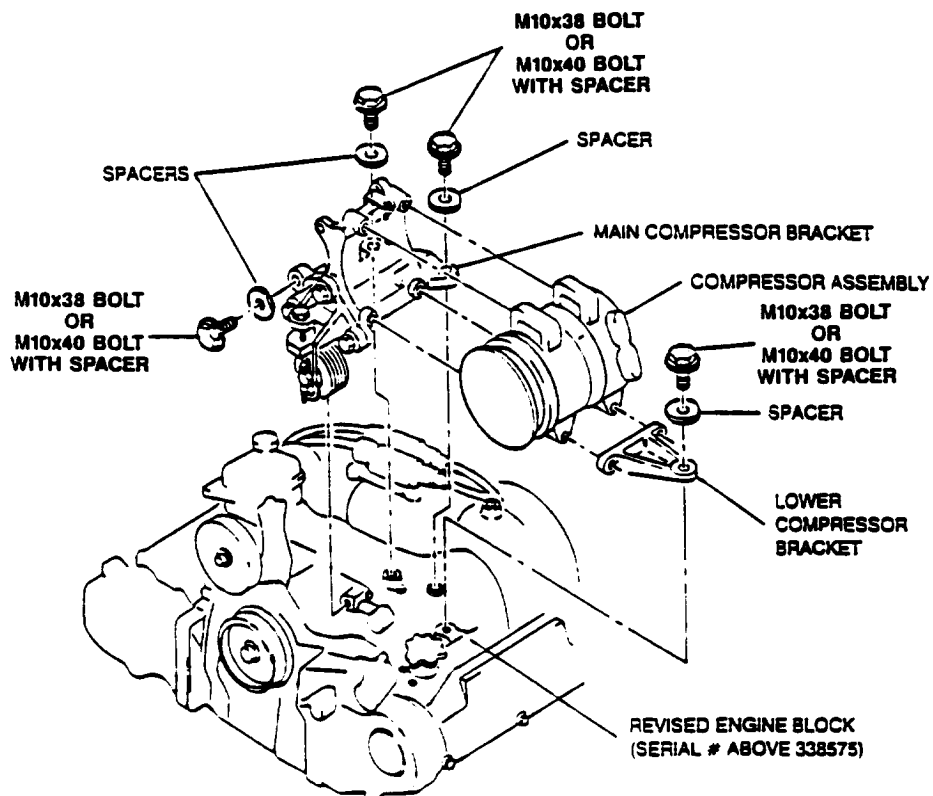

CAUTION: Damage to short block may result if spacer kit or shorter bolts are not used.

Revised A/C Kits P/N G3010AB000 and P/N G3010AB010 will initially have spacer kits supplied, a running production change will take place shortly thereafter, incorporating the shorter mounting bolts.

A/C kits will be identified, alerting installer as to which spacer or bolt kit is supplied.