

Development of a New All-Wheel Drive Control System

Koji Matsuno^{1)*} Ryo Nitta²⁾ Koichi Inoue³⁾ Katsufumi Ichikawa⁴⁾ Yutaka Hiwatashi⁵⁾

^{1) 2) 3) 4)} Fuji Heavy Industries co.,ltd., Japan

⁵⁾ SUBARU Research Center co.,ltd., Japan

The new all-wheel drive control system has been developed to improve stability on slippery road and handling performance on dry road. This control system realized advanced safety and controllability in the aspect of vehicle dynamics under various road/operating conditions by the estimation of the coefficient of road friction (μ) and development of cooperative controls with ABS, TCS (Traction Control System) and braking system for yaw control (VDC). The μ estimator was based on parameter identification law in adaptive control theory, and added effective modification according to lateral acceleration of vehicle to improve response of estimation. In the experimental results, the μ estimator fulfilled it's expectations, and our production car equipped with this control system showed sufficient handling performance, stability and controllability for an all-wheel drive vehicle under various road/operating conditions.

Keywords: All-wheel drive, Handling, Stability, Control system

INTRODUCTION

Recently, various chassis control systems were developed to improve safety in the aspect of vehicle dynamics. Along with this, sensors which used to yaw control systems were developed and became popular; for example, steering angle sensor, yaw velocity sensor, and acceleration sensor. Moreover, to achieve optimum and robustness of chassis controls under various situations, many attempts to estimate road conditions were published.

The new all-wheel drive control system (new VTD control; Variable Torque Distribution) has been developed to improve stability and handling performance under various road/operating conditions. This system use sensor signals for braking force control system (VDC; Vehicle Dynamics Control) which improves stability of vehicle, and includes cooperative controls with ABS, TCS and VDC to optimize the control performance for an all-wheel drive vehicle.

In this paper, the estimation technology to detect the coefficient of road friction (μ) which is the core of the new VTD control, and experimental results of vehicle equipped with this control system are presented.

SYSTEM CONFIGURATIONS

TRANSFER

Figure 1 shows a main cross section of an automatic transmission equipped with the new VTD control. An electronically controlled hydraulic transfer clutch is combined with center differential gear. This differential gear is in the form of composite planetary gear system without starter ring. It is light weight and compact and dose not place any limits on the torque distribution ratio.

The output torque of the transmission is distributed 36% to front wheels and 64% to rear wheels by this center differential gear. It improves the handling performance on high μ road when the hydraulic transfer clutch is open. On the other hand, when the low μ condition is detected or the yaw motion of vehicle is disturbed, the actual torque distribution is modified by the transfer clutch control to retain stability and safety for an all-wheel drive vehicle.

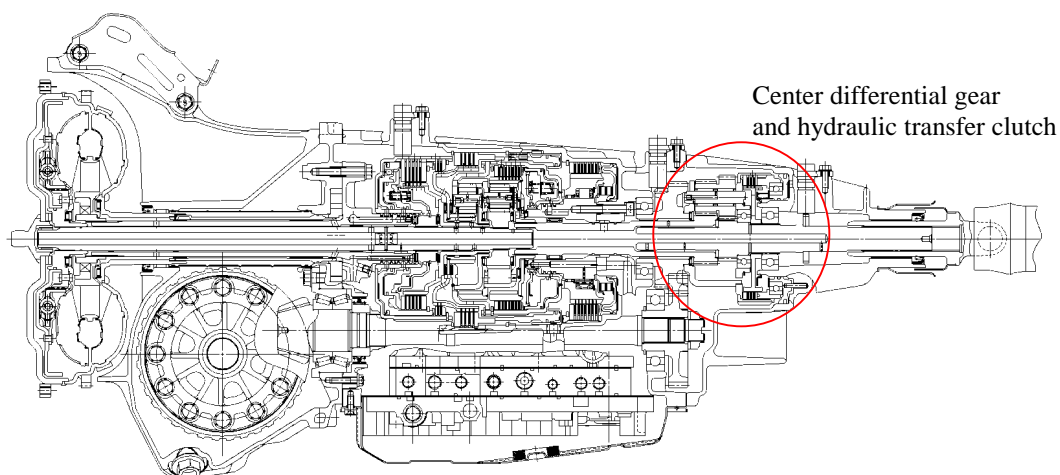

Figure 1 - New VTD transfer

CONSTRUCTION OF CONTROLLERS

Figure 2 shows the construction of controllers for the new VTD. In this system, controller area network (CAN) is used to build a efficient construction of sensors. First, sensor signals required to this all-wheel drive control system are inputted to the VDC controller. The corrected value of sensor signals are inputted to the controller of this all-wheel drive control system which included in the automatic transmission (E-AT) through the CAN. In the same way, operating states of VDC are inputted to realize the cooperative control with VDC. It achieves high controllability of wheel speed for ABS, TCS and VDC.

E-AT controller detects road condition (μ) and operating condition according to sensor signals for the transmission control and VDC. E-AT controller drives a PWM (Pulse Width Modulation) solenoid valve which controls hydraulic pressure of the transfer clutch.

CONTROL ALGORITHM

OUTLINE OF NEW VTD CONTROL

Control according to estimated μ

A basic value of the transfer torque (transferable torque of the clutch) is set according to the estimated μ . As shown in figure 3, tractive torque on the rear wheels are increased when the estimated μ is high, so that an sufficient handling performance which brought by the torque distribution ratio of the center differential is achieved. On the other hand, when the estimated μ is low, the transfer torque is increased, and the stability of the vehicle is improved.

Yaw velocity feedback control

The transfer torque according to the estimated μ is modified according to a deviation between actual yaw velocity and target yaw velocity. The target yaw velocity is calculated from steering angle and vehicle speed. When actual yaw velocity is smaller than the target yaw velocity (understeer behavior is excessive), the transfer torque is decreased to improve steering response. The other way, the transfer torque is increase when actual yaw velocity is large (oversteering behavior), so that stability of vehicle is improved. It insure a driver against unexpected spin motion of vehicle.

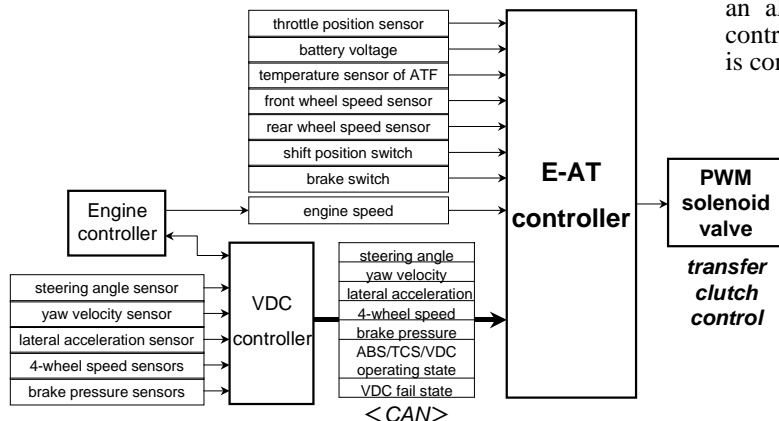

Figure 2 - Construction of controllers

Control according to steering angle

To get smooth differential function of the center differential, in order to reduce a running drag and to improve a steer feeling in tight turn, the transfer torque is decreased according to steering angle when the vehicle speed is very low. However, the transfer torque is not decreased below a value setting from estimated μ . It keep the vehicle stable when the vehicle makes a standing start with steer on slippery road.

Control for throttle-off in cornering

If the throttle is rapidly released in hard cornering or on slippery road, the vehicle may show oversteering behavior. In the new VTD control, when hard cornering is observed from yaw velocity and vehicle speed, and an throttle-off situation is detected, the transfer torque is increased to retain sufficient stability.

Control during braking or ABS operates

When the center differential is locked, wheel speed of each wheels can not be controlled independently. The other hand, especially on icy road, vertical load of rear wheel may be insufficient to recover it's wheel speed quickly from nearly wheel lock situation. A optimum distribution of a engine braking torque and inertia of engine and transmission between front and rear wheels has a effect of improving recovery of rear wheel speed. In the new VTD control, when hard braking with ABS operates or forecasted of the operation of ABS, the transfer torque is set to suitable value to improve controllability of wheel speed for ABS.

Control during TCS operates

When TCS(Traction Control System) operates, a suitable transfer torque corresponding to the vehicle speed is applied to decrease interference of drive train. It not only improves controllability of wheel speed of each wheels on split μ surface, but also prevents simultaneous wheel slip of all wheels which brings unstable behavior of an all-wheel drive vehicle. By this control, an enough traction performance and stability as an all-wheel drive vehicle are achieved under various road/operating conditions.

Control during VDC operates

To secure a high performance of handling and stability for an all-wheel drive vehicle, and to improve safety and controllability under critical situations, the transfer torque is controlled according to the operation state of VDC.

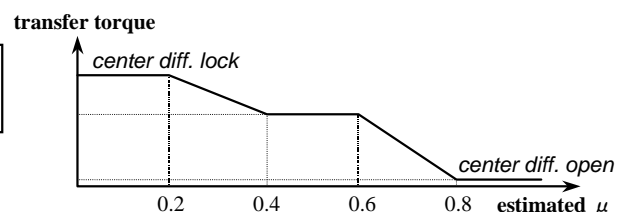

Figure 3 - Transfer torque according to estimated μ

LOGIC OF μ ESTIMATION

The μ estimation is realized by the identification of actual cornering stiffness of tire in the adaptive model of vehicle dynamics. It based on parameter identification law of adaptive control theory. In this control system, μ is estimated by comparing identified value of cornering stiffness of tire with reference value on the high μ road.

As the μ estimation technology, many papers (1)*-(8) which used adaptive control theory including the estimation of cornering stiffness of tire were published. In papers of (9)-(13), μ estimation from the acceleration of vehicle when ABS/TCS operates or the braking/driving force acts on vehicle were proposed and has been put to practical use. Moreover, method (14),(15) detect μ from the self aligning torque of tire which acts on steering system.

In the new VTD control, we chose the parameter identification law of adaptive control theory for unnecessary of additional sensors, and robustness and sensitivity of estimation. Figure 4 shows the outline of μ estimator.

In addition, we use modification of μ estimation based on the lateral acceleration of vehicle to improve response of estimation. This modification is also effective when input signals for parameter identification is not sufficient. Because, In adaptive control theory, identification signals must have the PE (Persistently Exciting) characteristic.

Figure 5 shows linearized 2-wheels model of vehicle dynamics. The response of yaw velocity $\Psi(t)$ depends on steering angle $\theta_H(t)$ can be represented as follows (3).

$$G(p)\dot{\psi}(t) = H_f(p)\theta_H(t) \quad \cdot \cdot \cdot (1)$$

$$G(p) = p^2 - a_{y1}(2/V)p + a_{y2}(2/V)^2 + 2 \cdot a_{y3}$$

$$a_{y1} = a_{11} + a_{22}$$

$$a_{y2} = a_{11} \cdot a_{22} - a_{12} \cdot a_{21}$$

$$a_{y3} = a_{12}$$

$$H_f(p) = b_{y1} \cdot p + b_{y2}(2/V)$$

$$b_{y1} = b_1$$

$$b_{y2} = a_{12} \cdot b_2 - a_{22} \cdot b_1$$

$$p : \text{derivative operator}$$

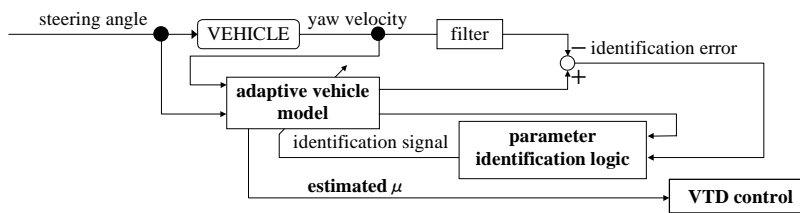

Figure 4 - μ estimator

$$a_{11} = -(L_f^2 \cdot K_f + L_r^2 \cdot K_r) / I_z$$

$$a_{12} = -(L_f \cdot K_f - L_r \cdot K_r) / I_z$$

$$a_{21} = -(L_f \cdot K_f - L_r \cdot K_r) / M$$

$$a_{22} = -(K_f + K_r) / M$$

$$b_1 = 2 \cdot L_f \cdot K_f / (I_z \cdot n)$$

$$b_2 = 2 \cdot K_f / (M \cdot n)$$

V : vehicle speed n : steering gear ratio

M : mass of vehicle I_z : yaw inertia of vehicle

L_f, L_r : distance between front and rear wheels to c.g.

K_f, K_r : cornering stiffness of tire

In this model, the cornering stiffness of tire includes the effect of suspension. Where we introduce stable polynomial expression $Q(p)$ and $D(p)$ as follows.

$$Q(p) = Q_1(p)D(p) \quad \cdot \cdot \cdot (2)$$

$$Q_1(p) = p + q_1 (q_1 > 0)$$

$$D(p) = p + d_1 (d_1 > 0)$$

by use of this stable polynomial expression, non-minimal realization of Eq (1) is

$$\begin{aligned} \dot{\psi}(t) - \{(q_1 + d_1)p + q_1 \cdot d_1\}Q^{-1}(p) \cdot \dot{\psi}(t) \\ = \{a_{y1}(2/V)p - a_{y2}(2/V)^2 - 2 \cdot a_{y3}\}Q^{-1}(p) \cdot \dot{\psi}(t) \\ + \{b_{y1} \cdot p + b_{y2}(2/V)\}Q^{-1}(p) \cdot \theta_H(t) \quad \cdot \cdot \cdot (3) \end{aligned}$$

The following equation is equivalent to Eq (3).

$$\eta(t) = \zeta^T \xi(t) \quad \cdot \cdot \cdot (4)$$

$$\eta(t) = \dot{\psi}(t) - \{(q_1 + d_1)p + q_1 \cdot d_1\}Q^{-1}(p) \cdot \dot{\psi}(t)$$

$$\zeta^T = [a_{y1} \quad a_{y2} \quad a_{y3} \quad b_{y1} \quad b_{y2}]$$

$$\xi^T(t) = Q^{-1}(p) \left[(2/V)p \cdot \dot{\psi}(t) \quad - (2/V)^2 \dot{\psi}(t) \right. \\ \left. - 2 \cdot \dot{\psi}(t) \quad p \cdot \theta_H(t) \quad (2/V)\theta_H(t) \right]$$

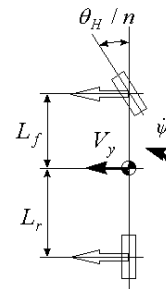

Figure 5 - Linearized 2-wheels vehicle model

RESULTS OF VEHICLE DYNAMICS

Figure 8 shows trace line of c.g. and slip angle of all-wheel drive vehicles when accelerating while turning on a wet asphalt. In this test, steering angle was fixed. An excellent handling performance and stability were achieved by the new VTD control.

On the other hand, when the center differential was open, tractive force of rear wheels were too large to retain stability of vehicle. This vehicle showed spin motion. In the opposite way, when the center differential was locked, understeer behavior was too excessive to achieve excellent handling performance. Our conventional all-wheel drive control system which was not equipped with μ estimation showed enough stability, but transfer clutch torque was rather large under this situation. This control has been developed to improve stability on more slippery road.

Figure 9 shows appreciation results of steering behaviour on snow covered road under usual operating condition. We introduce the momentary stability factor (S.F.) (17) as the index of the steering behaviour of vehicle.

$$K = \frac{\theta_H / n \cdot V}{\dot{\psi} \cdot L} - 1 \quad \dots (9)$$

K : momentary stability factor

L : wheelbase

From the average of momentary S.F., it can be said that the new VTD control had moderate steering behaviour the same as locked center differential. New VTD control system detected slippery road condition, and the enough transfer torque was applied. Moreover, the new VTD control improves variance and distortion of momentary S.F..

$$Distortion = \frac{1}{\sigma^3} \cdot \frac{1}{m} \sum_{i=1}^m (x_i - \bar{X})^3 f_i$$

σ : standard deviation

m : total frequency \bar{X} : average

f_i : frequency

The vehicle which center differential was open showed small distortion too, but the average of momentary S.F. was small. This shows possibility of changing to oversteer behaviour. On the other hand, the vehicle which center differential was locked showed positive and large value of distortion. It explains possibility of excessive understeer behaviour. The transfer torque control of yaw velocity feedback according to target yaw velocity which applied new VTD control system brought stable steering behaviour of vehicle.

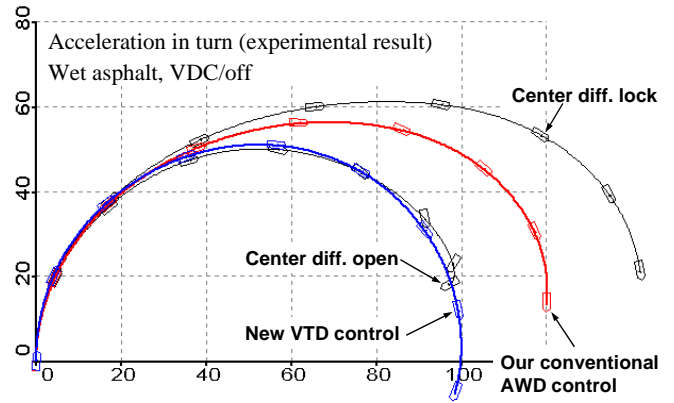

Figure 8 - Experimental results of vehicle dynamics on wet asphalt

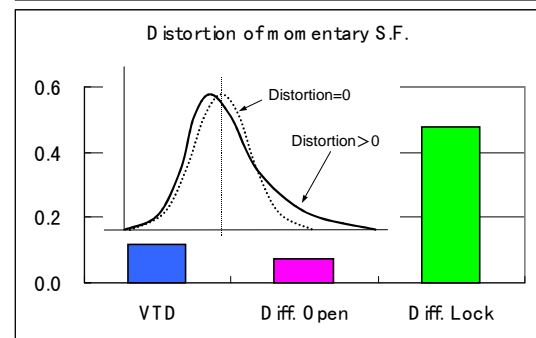
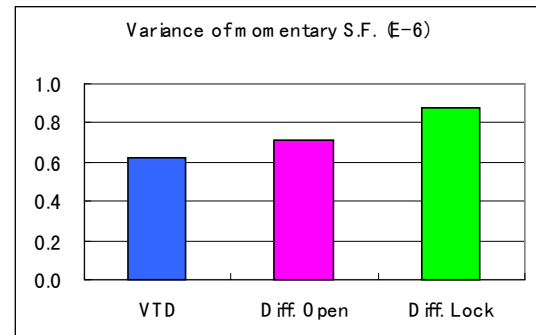
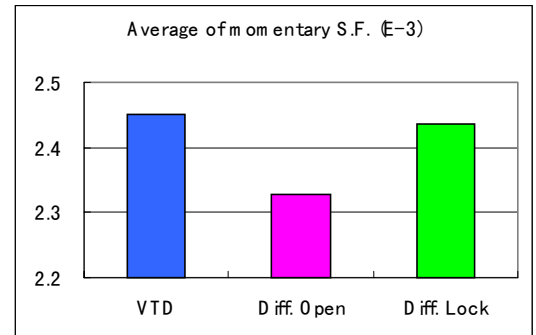

Figure 9 - Appreciation results of steering behavior on snow covered road

COOPERATED CONTROL WITH VDC

Figure 10 shows the time domain data of wheel speed and hydraulic pressures of brake during VDC operation on icy road. When the center differential was open, recovery of wheel speed after release of braking force was slow. On the other hand, when the center differential was locked, counter torque of braking force acts on opposite side wheel. It caused other wheels from the wheel applied braking force slipped up.

In the new VTD control, the controllability of wheel speed was improved by the optimizing of transfer torque control when VDC operated, and excellent safety was achieved as an all-wheel drive vehicle equipped with VDC.

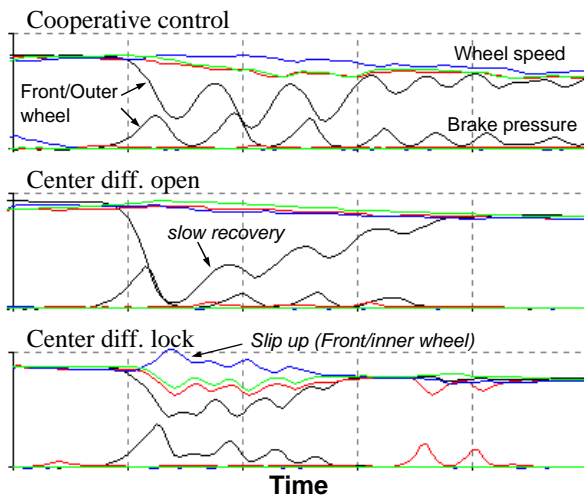

Figure 10 - Cooperated control with VDC

CONCLUSION

The all-wheel drive control system to improve handling performance and stability has been developed. It was realized by the efficient constructions of sensors for VDC with the CAN and the development of the estimation technology to detect road conditions.

- (1) The μ estimation technology has been put to practical use by adding the modification to parameter identification law of adaptive control theory according to lateral acceleration of vehicle.
- (2) We obtained the experimental results which showed the effects of optimized transfer torque control according to μ estimation and yaw velocity feedback to improve handling performance and stability under various road/operating conditions.
- (3) Enough stability and controllability for an all-wheel drive vehicle under critical situations were achieved by the cooperated control with VDC.

REFERENCES

- [1] Kanai et al. : Design of Adaptive Yaw Rate Control System of a Car, Technical papers of Sensing Instrument Control Engineering Systems Information Computer Ergonomics, Vol.23, No.8 (1987)
- [2] Kanai et al. : Design of Adaptive-Type Yaw Rate, Lateral Acceleration and D*-Controllers for 4-Wheel Steering Car, Technical papers of Sensing Instrument Control Engineering Systems Information Computer Ergonomics, Vol.24, No.4 (1988)
- [3] Kanai : Robust Adaptive Control, ohm-sha, p.119-124 (1989)
- [4] Wang and Nagai : Improvement of the Circling Stability of a Commercial Vehicle by Adaptive Control, Technical papers of The 68th JSME (Japan Society of Mechanical Engineers) Spring Annual Meeting (Vol.C) (1991)
- [5] Kawanabe : Adaptive Control and 4-Wheel Steering, Text of SICE basic course - adaptive control (1992)
- [6] Wakamatsu et al. : Adaptive Yaw Rate Feedback 4WS with Friction Coefficient Estimator between Tire and Road Surface, AVEC'96 (1996)
- [7] Chia-Shang et al. : Road Friction Estimation For Vehicle Path Prediction, Vehicle System Dynamics Supplement 25 (1996)
- [8] Kaminaga et al. : Vehicle Body Slip Angle Estimation Using an Adaptive Observer, Proceeding of JSAE (Society of Automotive Engineers of Japan) 9832693 (1998)
- [9] Fukumura et al. : The method of optimizing Traction Control System (TCS) - and an application to vehicle dynamics control system -, Proceeding of JSAE (Society of Automotive Engineers of Japan) 9636961 (1996)
- [10] Kageyama et al. : A Study of Anti-Lock Braking Systems with μ Estimation, AVEC '96 (1996)
- [11] Yamazaki et al. : Evaluation of Friction Coefficient between Tire and Road Surface during Running, Journal of the Society of Automotive Engineers of Japan Vol.51, No.11 (1997)
- [12] Miyazaki et al. : Accurate and Real Time Measurement of Road Surface Friction Coefficient between the Road Surface and Tire. Second Report: Verification Based on the Running Tests with the One-segment Sensing Method, Proceeding of JSAE (Society of Automotive Engineers of Japan) 9831766 (1998)
- [13] Yi et al. : Estimation of Tire-Road Friction Using Observer Based Identifiers, Vehicle System Dynamics, 31 (1999)

- [14] Tani et al. : The Current Status of Intelligent Chassis Control, Journal of the Society of Automotive Engineers of Japan Vol.48, No.1 (1994)
- [15] Pasterkamp et al. :The Tyre as a Sensor to Estimate Friction, Vehicle System Dynamics, 27 (1997)
- [16] Naik et al. :Robust Continuous Time Adaptive Control by Parameter Projection, IEEE TRANSACTIONS ON AUTOMATIC CONTROL, Vol.37, No.2 (1992)
- [17] Ookubo et al. : Handling characteristics on uneven road surface in a turn, Proceeding of JSAE (Society of Automotive Engineers of Japan) 9932791 (1999)