



## INSTALLATION INSTRUCTION

GENUINE PARTS

# LEGACY AIR FILTER KIT

Part No.: G3210AE000

Applicable Model: LEGACY 2000MY

Component parts (Confirm component parts before you start installation.)

No.	Component parts	Q'ty	Remarks
1	Filter assembly	1	Upper
2	Filter assembly	1	Lower
3	Label	1	Filter replacement
4	Label	1	Caution

Tools: Screwdriver, Phillips screwdriver

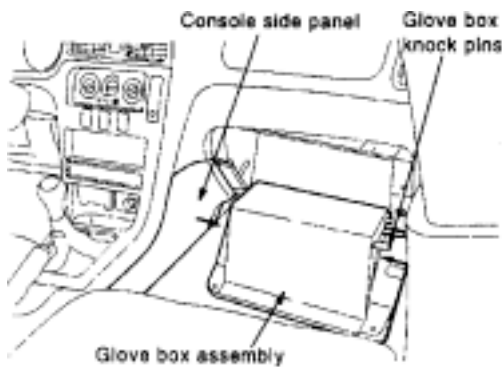

### Installation process

#### 1. COVER REMOVAL

- (1) Remove the glove box assembly as follows.
  - 1.1 Push in the sides of the glove box to unhook the knock pins.
  - 1.2 Remove the glove box installation screws.
  - 1.3 Remove the console side panel.
  - 1.4 Disconnect the glove box illumination harness connector and remove the glove box assembly. Remove the knock pins to facilitate later reinstallation.

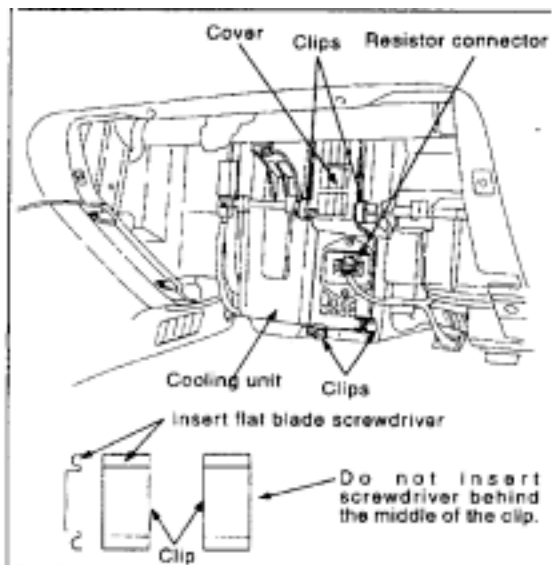

- (2) Disconnect the resistor connector. Remove the cover from the cooling unit by removing the four clips with a flat blade screwdriver.

The screwdriver must be inserted into the top of the clip. Do not pry the middle of the clip.

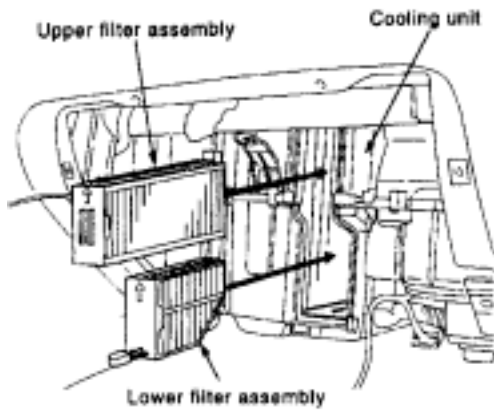

## 2. FILTER INSTALLATION

- (1) Install the upper filter assembly in the cooling unit, then install the lower filter assembly.

**Note:**

- The passenger compartment side of each filter is marked with an arrow. Ensure the arrow points up.
- Ensure each filter assembly's tongues and grooves fit the corresponding cooling unit and matching filter tongues and grooves.

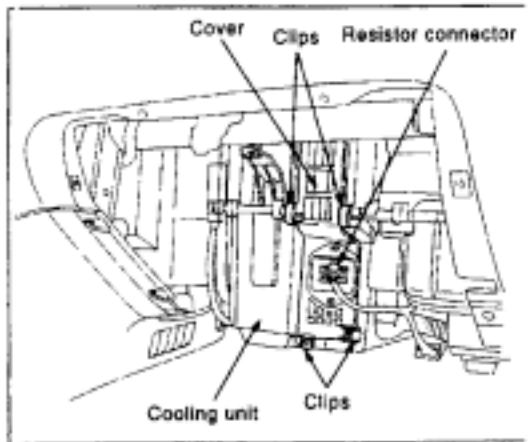

- (2) Reinstall the cover, secure it using the clips and reconnect the resistor connector.

**Note:**

Ensure no air leaks from the cooling unit through the cover.

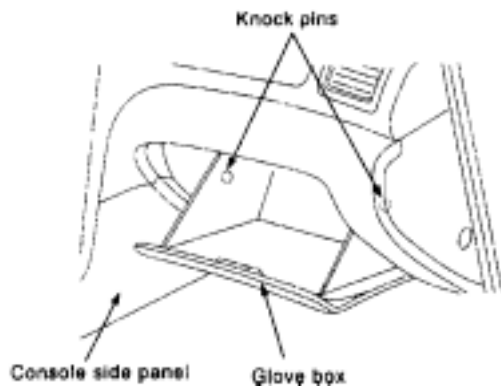

- (3) Reinstall the glove box assembly as follows.

- 3.1 Reconnect the glove box illumination harness connector and reinstall the glove box assembly.
- 3.2 Reinstall the console side panel.
- 3.3 Reinstall the glove box installation screws.
- 3.4 Lift the glove box and reinstall the knock pins.

**Note:**

Ensure the knock pins are properly inserted into the glove box assembly grooves.