

ATTENTION:
 GENERAL MANAGER PARTS MANAGER
 CLAIMS PERSONNEL SERVICE MANAGER
 IMPORTANT - All Service Personnel Should Read and Initial



SERVICE BULLETIN

APPLICABILITY: 1999~2004MY Subaru Vehicles
SUBJECT: Service Manual Corrections

NUMBER: 18-74-04
DATE: 01/15/04

INTRODUCTION

Place a REVISED label on the appropriate pages of the noted effected Service Manuals and update the appropriate Service Manual Correction Binder(s) with the following pages:

YEAR	MODEL	BOOK/VOL#	MSA#	SECTION	PAGE	REFERENCE
1999	Forester	Sect. 1	MSA5T9910A	1-3	13	G5C0
	Forester	Sect. 1	MSA5T9910A	1-3	15	G5G0
	Forester	Sect. 1	MSA5T9910A	1-5	14	G6A1
	Forester	Sect. 2	MSA5T9911A	2-2	11	W8B0
	Impreza	Sect. 1	MSA5T9901A	1-3	6	G5C0
	Impreza	Sect. 1	MSA5T9901A	1-3	8	G5E0
	Impreza	Sect. 1	MSA5T9901A	1-5	13	G6A1
	Impreza	Sect. 2	MSA5T9902A	2-5	6	W1A0
2000	Forester	Sect. 1	MSA5T0020A	1-3	13	G5C0
	Forester	Sect. 1	MSA5T0020A	1-3	15	G5G0
	Forester	Sect. 1	MSA5T0020A	1-5	12	G6A1
	Forester	Sect. 3	MSA5T0022A	2-5	25	W9B1
	Impreza	Sect. 1	MSA5T0010A	1-3	13	G5C0
	Impreza	Sect. 1	MSA5T0010A	1-3	15	G5G0
	Impreza	Sect. 1	MSA5T0010A	1-5	12	G6A1
	Impreza	Sect. 3	MSA5T0012A	2-5	22	W9A0
	Legacy	Sect. 1	MSA5T0001A	1-3	13	G5C0
	Legacy	Sect. 1	MSA5T0001A	1-3	15	G5G0
	Legacy	Sect. 1	MSA5T0001A	1-5	11	G6A2
	Legacy	Sect. 3	MSA5T0003A	2-5	23	W9B1
2001	Forester	Sect. 1	MSA5T0120A	1-3	13	G5C0
	Forester	Sect. 1	MSA5T0120A	1-5	12	G6A1
	Forester	Sect. 1	MSA5T0120A	1-3	15	G5G0
	Forester	Sect. 3	MSA5T0122A	2-5	24	W9B0
	Impreza	Sect. 2	MSA5T0111A	--	CO-6	--
	Impreza	Sect. 1	MSA5T0110A	--	PM-18	--
	Impreza	Sect. 1	MSA5T0110A	--	RM-4	--

continued on next page...



CAUTION: VEHICLE SERVICING PERFORMED BY UNTRAINED PERSONS COULD RESULT IN SERIOUS INJURY TO THOSE PERSONS OR TO OTHERS.

Subaru Service Bulletins are intended for use by professional technicians ONLY. They are written to inform those technicians of conditions that may occur in some vehicles, or to provide information that could assist in the proper servicing of the vehicle. Properly trained technicians have the equipment, tools, safety instructions, and know-how to do the job correctly and safely. If a condition is described, DO NOT assume that this Service Bulletin applies to your vehicle, or that your vehicle will have that condition.



YEAR	MODEL	BOOK/VOL#	MSA#	SECTION	PAGE	REFERENCE	
2001	Legacy	Sect. 2	MSA5T0102A	--	CO(H4)-6	--	
	Legacy	6 Cyl. Sup.	MSA5T0109A	--	CO(H6)-18	--	
	Legacy	6 Cyl. Sup.	MSA5T0109A	--	PM-19	--	
	Legacy	6 Cyl. Sup.	MSA5T0109A	--	RM-4	--	
	Legacy	Sect. 1	MSA5T0101A	--	PM-18	--	
	Legacy	Sect. 1	MSA5T0101A	--	RM-4	--	
2002	Forester	Sect. 3	MSA5T0222A	--	CO-12	--	
	Forester	Sect. 3	MSA5T0222A	--	CO-13	--	
	Forester	Sect. 1	MSA5T0220A	--	PM-14	--	
	Forester	Sect. 1	MSA5T0220A	--	RM-4	--	
	Impreza	Sect. 2	MSA5T0211A	--	CO-25	--	
	Impreza	Sect. 1	MSA5T0210A	--	PM-18	--	
	Impreza	Sect. 1	MSA5T0210A	--	RM-4	--	
	Legacy	Sect. 3	MSA5T0203A	--	CO(H6)-18	--	
	Legacy	Sect. 2	MSA5T0202A	--	CO-12	--	
	Legacy	Sect. 1	MSA5T0201A	--	PM-18	--	
	Legacy	Sect. 1	MSA5T0201A	--	RM-5	--	
	2003	Forester	Sect. 3	MSA5T0322A	--	CO(SOHC)-14	--
Forester		Sect. 1	MSA5T0320A	--	PM-17	--	
Forester		Sect. 1	MSA5T0320A	--	RM-4	--	
Impreza		Sect. 2	MSA5T0311A	--	CO(H4SO)-29	--	
Impreza		Sect. 1	MSA5T0310A	--	PM-19	--	
Impreza		Sect. 1	MSA5T0310A	--	RM-5	--	
Legacy		Sect. 2	MSA5T0302A	--	CO(H4SO)-14	--	
Legacy		Sect. 3	MSA5T0303A	--	CO(H6DO)-22	--	
Legacy		Sect. 1	MSA5T0301A	--	PM-19	--	
Legacy		Sect. 1	MSA5T0301A	--	RM-4	--	
2004		Forester	Sect. 2	MSA5T0421A	--	CO(H4SO)-17	--
		Forester	Sect. 1	MSA5T0420A	--	PM-19	--
	Forester	Sect. 1	MSA5T0420A	--	RM-4	--	
	Impreza	Sect. 3	MSA5T0412A	--	CO(H4DOTC)-17	--	
	Impreza	Sect. 2	MSA5T0411A	--	CO(H4SO)-12	--	
	Impreza	Sect. 1	MSA5T0410A	--	PM-20	--	
	Impreza	Sect. 1	MSA5T0410A	--	RM-6	--	
	Legacy	Sect. 4	MSA5T0403A	--	CO(H4DOTC)-13	--	
	Legacy	Sect. 2	MSA5T0401A	--	CO(H4SO)-12	--	
	Legacy	Sect. 5	MSA5T0404A	--	CO(H6DO)-18	--	
	Legacy	Sect. 1	MSA5T0400A	--	PM-22	--	
	Legacy	Sect. 1	MSA5T0400A	--	RM-4	--	

C: LUBRICANTS

Lubricants	Specifications	Remarks
<ul style="list-style-type: none"> • Engine oil 	<ul style="list-style-type: none"> • API Classification: SJ or SH with the words "Energy Conserving or Energy Conserving II" • New API Certified • CCMC Specification: G4 or G5 • ACEA Specification: A1 or A2 or A3 	<ul style="list-style-type: none"> • For SAE viscosity number, refer to the following table. • If it is impossible to get SJ or SH grade, you may use SG grade.
<ul style="list-style-type: none"> • Transmission and differential gear oil • AWD rear differential gear oil 	<ul style="list-style-type: none"> • API Classification: GL-5 	<ul style="list-style-type: none"> • For SAE viscosity number, refer to the following table.
<ul style="list-style-type: none"> • Automatic transmission 	<ul style="list-style-type: none"> • "DEXRON IIE" or "DEXRON III" type 	—
<ul style="list-style-type: none"> • Power steering fluid 	<ul style="list-style-type: none"> • "DEXRON IIE" or "DEXRON III" type 	—
<ul style="list-style-type: none"> • Coolant 	<ul style="list-style-type: none"> • Genuine SUBARU Coolant (Part No. 000016218) (Anti-freeze, anti-corrosive ethylene glycol base) 	<ul style="list-style-type: none"> • For further coolant specifications, refer to the following table.
<ul style="list-style-type: none"> • Coolant Conditioner 	<ul style="list-style-type: none"> • Subaru Coolant Conditioner SOA635071 	—
<ul style="list-style-type: none"> • Brake fluid 	<ul style="list-style-type: none"> • DOT3 or DOT4 	<ul style="list-style-type: none"> • FMVSS NO. 116 • Avoid mixing brake fluid of different brands to prevent the fluid performance from degrading. • When brake fluid is added, be careful not to allow any dust into the reservoir.
<ul style="list-style-type: none"> • Clutch fluid 	<ul style="list-style-type: none"> • DOT3 or DOT4 	<ul style="list-style-type: none"> • FMVSS NO. 116 • Avoid mixing brake fluid of different brands to prevent the fluid performance from degrading. • When brake fluid is added, be careful not to allow any dust into the reservoir.

Lubricants	Recommended	Application	Equivalent
<ul style="list-style-type: none"> • Spray lubricants 	SUBARU CRC (P/N 004301003)	O ₂ sensor	—
<ul style="list-style-type: none"> • Grease 	SUNLIGHT 2 N: glube R (P/N 003602010)	Steering shaft bearing, bushing for manual transmission gear shift system	—
	Valiant grease M-2 (P/N 003608001)	Steering gearbox	—
	Niglube RX-2 (P/N 003606000 or 725191040)	Piston boot of disc brake and sliding pin	—
	Molykote No. 7439 (P/N 725191460)	Contacting surfaces of drum brake shoes and shoe clearance adjuster	—
	Molylex No.2 (P/N 723223010)	Rear BJ and DOJ (for except front axle of AT vehicle) joints of axle shafts	—
	NTG2218 (CP/N 28093AA020)	BJ (for front axle) joints of axle shafts	—
	FX clutch grease (P/N 000040901)	Splines of transmission main shaft	—
	Slicolube G-30M (P/N 004404002)	Control cables and throttle linkages subject to cold weather, water-pump impeller, door latch, striker, battery terminals, etc.	—
SSG-6003 (P/N 28093TA000)	SFJ joints of axle shafts	—	

E: COOLANT

CAUTION:

- Avoid using any coolant or only water other than this designated type to prevent corrosion.
- SUBARU's engine is aluminum alloy, and so special care is necessary.
- To prevent cooling system leaks, always add Genuine Subaru Cooling System Conditioner (Part No. SOA635071) whenever the coolant is replaced.

Coolant Specifications							
Lowest anticipated atmospheric temperature	SUBARU coolant-to-*water ratio (Volume) %	Specification gravity					Freezing point
		at 10°C (50°F)	at 20°C (68°F)	at 30°C (86°F)	at 40°C (104°F)	at 50°C (122°F)	
Above -30°C (-22°F)	50 — 50	1.084	1.079	1.074	1.068	1.062	-36°C (-33°F)
Above -15°C (5°F)	30 — 70	1.053	1.049	1.044	1.039	1.034	-16°C (-3°F)

*: It is recommended that distilled water be used.

F: SEALANTS

	Recommended	Application	Equivalent
Sealant	Three Bond 1105 (P/N 004403010)	Rear differential oil drain plug, bearing cap (#5), etc.	Dow Corning's No. 7038
	Three Bond 1215 (P/N 004403007)	Matching surface of oil pump, transmission case, etc. Flywheel and drive plate tightening bolts, etc.	Dow Corning's No. 7038
	Starcalking B-33A (P/N 000018901)	Sealing against water and dust entry through weatherstrips, grommets, etc.	Butyl Rubber Sealant
	Three Bond 1217B	Matching surface of transmission oil pan	—
	Three Bond 1102 (P/N 004403006)	Steering gear box adjust screw	—
	Three Bond 1280B	Matching surface of engine cam cap	—

G: ADHESIVES

Adhesive	Cemedine 5430L	Weatherstrips and other rubber parts, plastics and textiles except soft vinyl parts.	3M's EC-1770 EC-1368
	Cemedine 540	Soft vinyl parts, and other parts subject to gasoline, grease or oil, e.g. trim leather, door inner remote cover, etc.	3M's EC-776 EC-847 EC-1022 (Spray Type)
	Cemedine 3000	Bonding metals, glass, plastic and rubber parts. Repairing slightly torn weatherstrips, etc.	Armstrong's Eastman 910
	Essex Chemical Crop's Urethane E	Windshield to body panel.	Sunstar 580

6. Replace Engine Coolant and Inspect Cooling System, Hoses and Connections

MAINTENANCE INTERVAL																	
[Number of months or km (miles), whichever occurs first]																	
Months	3	7.5	15	22.5	30	37.5	45	52.5	60	67.5	75	82.5	90	97.5	105	112.5	120
× 1,000 km	4.8	12	24	36	48	60	72	84	96	108	120	132	144	156	168	180	192
× 1,000 miles	3	7.5	15	22.5	30	37.5	45	52.5	60	67.5	75	82.5	90	97.5	105	112.5	120
California					P				P				P				P
All states except California					P				P				P				P

A: REPLACEMENT

1. REPLACEMENT OF COOLANT

WARNING:

The radiator is of the pressurized type. Do not attempt to open the radiator cap immediately after the engine has been stopped.

- 1) Lift up the vehicle.
- 2) Remove undercover.
- 3) Fit vinyl tube to drain pipe.

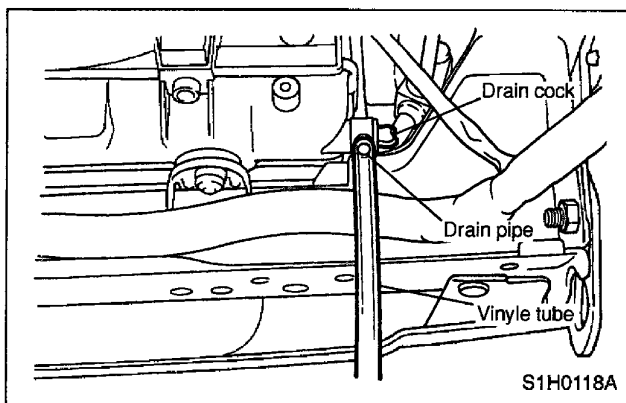

- 4) Place a container under vinyl tube.
- 5) Loosen drain cock to drain engine coolant into container.
- 6) For quick draining, open radiator cap.

CAUTION:

Be careful not to spill coolant on the floor.

- 7) Drain coolant from reservoir tank.
- 8) Tighten radiator drain plug securely after draining coolant. (Drain tube may face downward.)

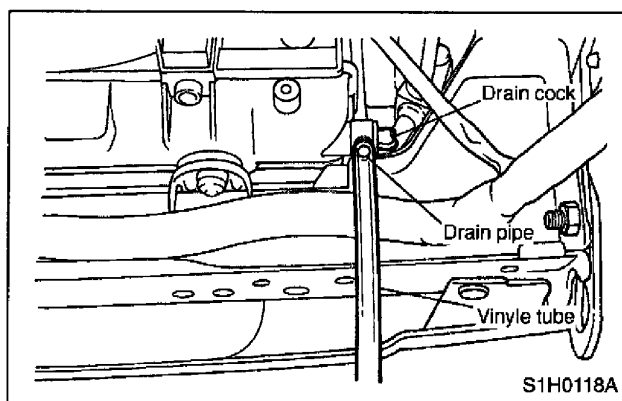

- 9) Fill engine coolant into radiator up to filler neck position.
- 10) Fill engine coolant into reservoir tank up to "FULL" level.

Coolant capacity (fill up to "FULL" level)
Approx. 6.0 ℓ (6.3 US qt, 5.3 Imp qt)

CAUTION: The SUBARU Genuine Coolant containing anti-freeze and anti-rust agents is especially made for SUBARU engines, which has an aluminum crankcase. Always use SUBARU Genuine Coolant, since other coolants may cause corrosion. To prevent cooling system leaks, always add Genuine Subaru Cooling System Conditioner (Part No. SOA635071) whenever the coolant is replaced.

- 11) Securely install radiator cap and reservoir tank cap.
- 12) Run engine for more than five minutes at 2,000 to 3,000 rpm. (Run engine until radiator becomes hot in order to purge air trapped in cooling system.)
- 13) Stop engine and wait until coolant temperature lowers. Then open radiator cap to check

6) Similar to adjustment procedures used for #1 cylinder, adjust #2, #3 and #4 cylinder valve clearances.

NOTE:

Be sure to set cylinder pistons to their respective top dead centers on the compression stroke before adjusting valve clearances.

To set #3, #2 and #4 cylinder pistons to their top dead centers on the compression stroke, turn crankshaft pulley clockwise 90° at a time starting with arrow mark on left-hand camshaft sprocket facing up.

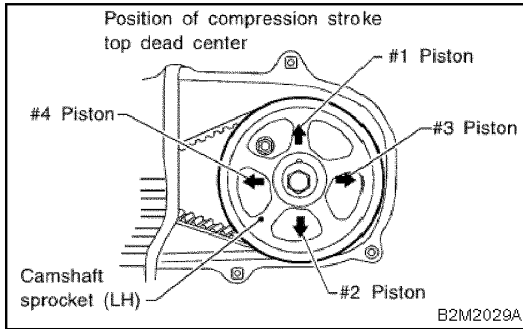

8. Engine Coolant

A: DRAINING OF ENGINE COOLANT

- 1) Lift-up the vehicle.
- 2) Remove under cover.
- 3) Fit vinyl tube to drain pipe.

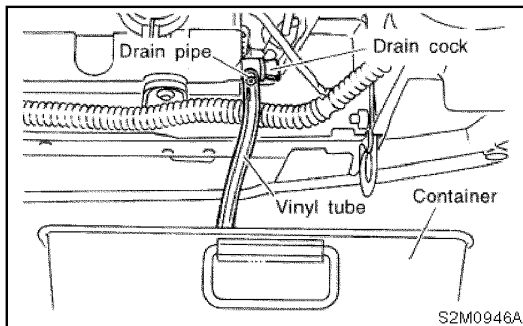

- 4) Loosen drain cock to drain engine coolant into container.

NOTE:

Remove radiator cap so that engine coolant will drain faster.

B: FILLING OF ENGINE COOLANT

- 1) Fill engine coolant into radiator up to filler neck position.

CAUTION: The Subaru Genuine Coolant containing anti-freeze and anti-rust agents is especially made for SUBARU engines, which have an aluminum crankcase. Always use SUBARU Genuine Coolant, since other coolant may cause corrosion. To prevent cooling system leaks, always add Genuine Subaru Cooling System Conditioner (Part No. SOA635071) whenever the coolant is replaced.

- 2) Fill engine coolant into reservoir tank up to upper level.

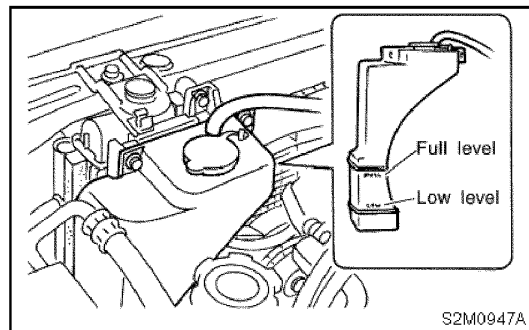

- 3) Attach radiator cap and reservoir tank cap properly.
- 4) Install air vent plug.
- 5) Warm-up engine completely for more than five minutes at 2,000 to 3,000 rpm.
- 6) Stop engine and wait until temperature drops to a safe level.
- 7) If engine coolant level drops in radiator, add engine coolant to filler neck position.
- 8) If engine coolant level drops from upper level of reservoir tank, add engine coolant to upper level.
- 9) Attach radiator cap and reservoir tank cap properly.

C: LUBRICANTS

Lubricants	Specifications	Remarks
<ul style="list-style-type: none"> Engine oil 	<ul style="list-style-type: none"> API Classification: SJ or SH with the words "Energy Conserving or Energy Conserving II" New API Certified CCMC Specification: G4 or G5 ACEA Specification: A1 or A2 or A3 	<ul style="list-style-type: none"> For SAE viscosity number, refer to the following table. If it is impossible to get SH or SG grade, you may use SF grade.
<ul style="list-style-type: none"> Transmission and differential gear oil AWD rear differential gear oil 	<ul style="list-style-type: none"> API Classification: GL-5 	<ul style="list-style-type: none"> For SAE viscosity number, refer to the following table.
<ul style="list-style-type: none"> Automatic transmission 	<ul style="list-style-type: none"> "DEXRON IIE" or "DEXRON III" type 	—
<ul style="list-style-type: none"> Power steering fluid 	<ul style="list-style-type: none"> "DEXRON IIE" or "DEXRON III" type 	—
<ul style="list-style-type: none"> Coolant 	<ul style="list-style-type: none"> Genuine SUBARU Coolant (Part No. 000016218) (Anti-freeze, anti-corrosive ethylene glycol base) 	<ul style="list-style-type: none"> For further coolant specifications, refer to the following table.
<ul style="list-style-type: none"> Coolant Conditioner 	<ul style="list-style-type: none"> Subaru Coolant Conditioner SOA635071 	
<ul style="list-style-type: none"> Brake fluid 	<ul style="list-style-type: none"> DOT3 or DOT4 	<ul style="list-style-type: none"> FMVSS NO. 116 Avoid mixing brake fluid of different brands to prevent the fluid performance from degrading. When brake fluid is added, be careful not to allow any dust into the reservoir.
<ul style="list-style-type: none"> Clutch fluid 	<ul style="list-style-type: none"> DOT3 or DOT4 	<ul style="list-style-type: none"> FMVSS NO. 116 Avoid mixing brake fluid of different brands to prevent the fluid performance from degrading. When brake fluid is added, be careful not to allow any dust into the reservoir.

Lubricants	Recommended	Application	Equivalent
<ul style="list-style-type: none"> Spray lubricants 	SUBARU CRC (P/N 004301003)	O ₂ sensor	—
<ul style="list-style-type: none"> Grease 	SUNLIGHT 2 N: glube R (P/N 003602010)	Steering shaft bearing, bushing for manual transmission gear shift system	—
	Valiant grease M-2 (P/N 003608001)	Steering gearbox	—
	Niglube RX-2 (P/N 003606000 or 725191040)	Piston boot of disc brake and sliding pin	—
	Molykote No. 7439 (P/N 725191460)	Contacting surfaces of drum brake shoes and shoe clearance adjuster	—
	Molylex No.2 (P/N 723223010)	BJ of rear axle shafts	—
	VU-3A702 (P/N 23223GA050)	DOJ of rear axle shafts	—
	NTG2218 (CP/N 28093AA020)	BJ of front axle shafts	—
	SSG-6003 (P/N 28093TA000)	SFJ of front axle shaft	—
	FX clutch grease (P/N 000040901)	Splines of transmission main shaft	—
	Slicolube G-30M (P/N 004404002)	Control cables and throttle linkages subject to cold weather, water-pump impeller, door latch, striker, battery terminals, etc.	—
Slicolube G-40M (P/N 004404003)	Clutch master cylinder push rod end	—	

E: COOLANT**CAUTION:**

- Avoid using any coolant or only water other than this designated type to prevent corrosion.
- SUBARU's engine is aluminum alloy, and so special care is necessary.
- To prevent cooling system leaks, always add Genuine Subaru Cooling System Conditioner (Part No. SOA635071) whenever the coolant is replaced.

Coolant Specifications							
Lowest anticipated atmospheric temperature	SUBARU coolant-to-*water ratio (Volume) %	Specification gravity					Freezing point
		at 10°C (50°F)	at 20°C (68°F)	at 30°C (86°F)	at 40°C (104°F)	at 50°C (122°F)	
Above -30°C (-22°F)	50 — 50	1.084	1.079	1.074	1.068	1.062	-36°C (-33°F)
Above -15°C (5°F)	30 — 70	1.053	1.049	1.044	1.039	1.034	-16°C (-3°F)

*: It is recommended that distilled water be used.

F: SEALANTS

	Recommended	Application	Equivalent
Sealant	Three Bond 1105 (P/N 004403010)	Rear differential oil drain plug, retainer bolt, etc.	Dow Corning's No. 7038
	Three Bond 1215 (P/N 004403007)	Matching surface of oil pump, transmission case, etc. Flywheel and drive plate tightening bolts, etc.	Dow Corning's No. 7038
	Starcalking B-33A (P/N 000018901)	Sealing against water and dust entry through weatherstrips, grommets, etc.	Butyl Rubber Sealant
	Three Bond 1102 (P/N 004403006)	Steering gear box adjust screw	—

G: ADHESIVES

Adhesive	Cemedine 5430L	Weatherstrips and other rubber parts, plastics and textiles except soft vinyl parts.	3M's EC-1770 EC-1368
	Cemedine 540	Soft vinyl parts, and other parts subject to gasoline, grease or oil, e.g. trim leather, door inner remote cover, etc.	3M's EC-776 EC-847 EC-1022 (Spray Type)
	Cemedine 3000	Bonding metals, glass, plastic and rubber parts. Repairing slightly torn weatherstrips, etc.	Armstrong's Eastman 910
	Essex Chemical Corp's Urethane E	Windshield to body panel.	Sunstar 580

6. Replace Engine Coolant and Inspect Cooling and Heating System, Hoses and Connections

MAINTENANCE INTERVAL																	
[Number of months or km (miles), whichever occurs first]																	
Months	3	7.5	15	22.5	30	37.5	45	52.5	60	67.5	75	82.5	90	97.5	105	112.5	120
× 1,000 km	4.8	12	24	36	48	60	72	84	96	108	120	132	144	156	168	180	192
× 1,000 miles	3	7.5	15	22.5	30	37.5	45	52.5	60	67.5	75	82.5	90	97.5	105	112.5	120
California					P				P				P				P
All states except California					P				P				P				P

A: REPLACEMENT

1. REPLACEMENT OF COOLANT

WARNING:

The radiator is of the pressurized type. Do not attempt to open the radiator cap immediately after the engine has been stopped.

- 1) Lift up the vehicle.
- 2) Fit vinyl tube to drain pipe.

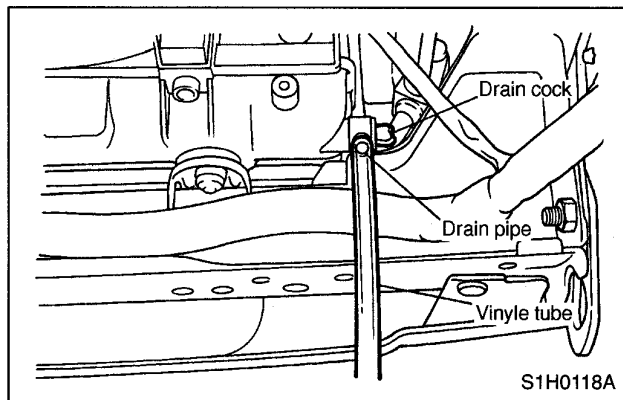

- 3) Place a container under vinyl tube.
- 4) Loosen drain cock to drain engine coolant into container.
- 5) For quick draining, open radiator cap.

CAUTION:

Be careful not to spill coolant on the floor.

- 6) Drain coolant from reservoir tank.
- 7) Tighten radiator drain cock securely after draining coolant. (Drain tube may face downward.)

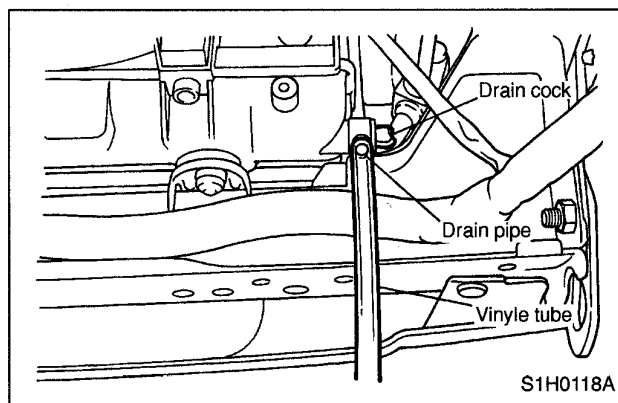

- 8) Fill engine coolant into radiator up to filler neck position.
- 9) Fill engine coolant into reservoir tank up to "FULL" level.

Coolant capacity (fill up to "FULL" level)
Approx. 6.2 ℓ (6.6 US qt, 5.5 Imp qt)

CAUTION: The Subaru Genuine Coolant Containing anti-freeze and anti-rust agents is especially made for SUBARU engines, which has an aluminum crankcase. Always use SUBARU Genuine Coolant, since other coolants may cause corrosion. To prevent cooling system leaks, always add Genuine Subaru Cooling System Conditioner (Part No. SOA635071) whenever the coolant is replaced.

- 10) Securely install radiator cap and reservoir tank cap.
- 11) Run engine for more than five minutes at 2,000 to 3,000 rpm. (Run engine until radiator becomes hot in order to purge air trapped in cooling system.)
- 12) Stop engine and wait until coolant temperature lowers. Then open radiator cap to check

1. On-car Services

A: DRAINING OF ENGINE COOLANT

- 1) Lift-up the vehicle.
- 2) Remove under cover.

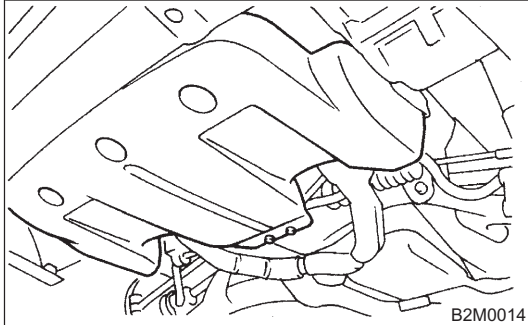

- 3) Fit vinyl tube to drain pipe.

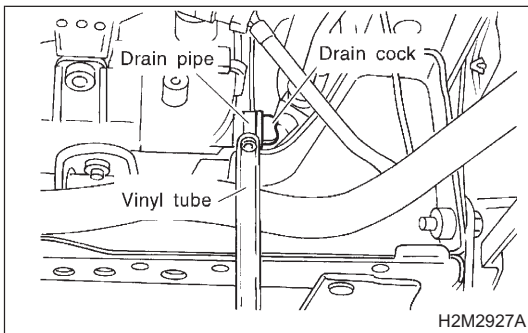

- 4) Loosen drain cock to drain engine coolant into container.

NOTE:

Remove radiator cap so that engine coolant will drain faster.

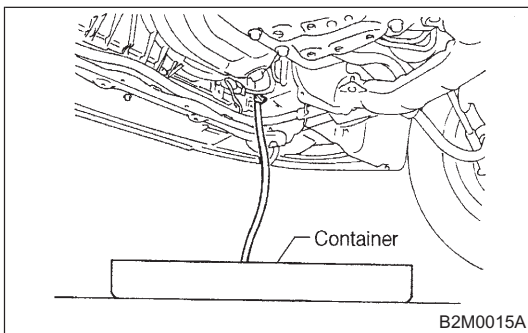

Caution: The Subaru Genuine Coolant containing anti-freeze and anti-rust agents is especially made for SUBARU engines, which has an aluminum crankcase. Always use SUBARU Genuine Coolant, since other coolants may cause corrosion. To prevent cooling system leaks, always add Genuine Subaru Cooling System Conditioner (Part No. SOA635071) whenever the coolant is replaced.

B: FILLING OF ENGINE COOLANT

- 1) Fill engine coolant into radiator up to filler neck position.
- 2) Fill engine coolant into reservoir tank up to upper level.

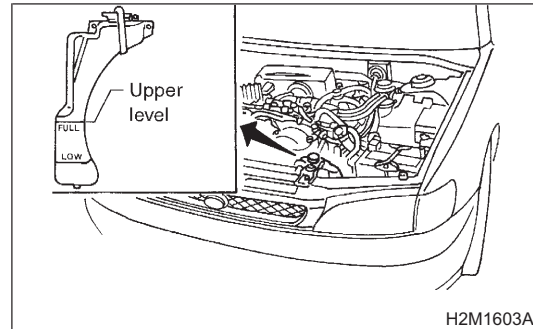

- 3) Attach radiator cap and reservoir tank cap properly.
- 4) Warm-up engine completely for more than five minutes at 2,000 to 3,000 rpm.
- 5) Stop engine and wait until temperature drops to a safe level.
- 6) If engine coolant level drops in radiator, add engine coolant to filler neck position.
- 7) If engine coolant level drops from upper level of reservoir tank, add engine coolant to upper level.
- 8) Attach radiator cap and reservoir tank cap properly.

C: CHECKING OF COOLING SYSTEM

- 1) Remove radiator cap, top off radiator, and attach tester to radiator in place of cap.
- 2) Apply a pressure of 157 kPa (1.6 kg/cm², 23 psi) to radiator to check if:
 - (1) Engine coolant leaks at/around radiator.
 - (2) Engine coolant leaks at/around hoses or connections.

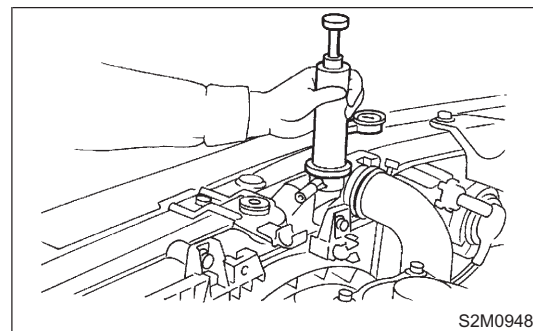

CAUTION:

Engine should be off.
Wipe engine coolant from check points in advance.
Be careful to prevent engine coolant from spurting out when removing tester.
Be careful also not to deform filler neck of radiator when installing or removing tester.

C: LUBRICANTS

Lubricants	Specifications	Remarks
Engine oil	API Classification: SJ or SH with the words "Energy Conserving II" New API Certified CCMC Specification: G4 or G5 ACEA Specification: A1, A2 or A3	For SAE viscosity number, refer to the following table. If it is impossible to get SJ or SH grade, you may use SG grade.
Transmission and differential gear oil AWD rear differential gear oil	API Classification: GL-5	For SAE viscosity number, refer to the following table.
Automatic transmission	"DEXRON II, IIE" or "DEXRON III" type	—
Power steering fluid	"DEXRON II, IIE" or "DEXRON III" type	—
Coolant	Genuine SUBARU Coolant (Part No. 000016218) (Anti-freeze, anti-corrosive ethylene glycol base)	For further coolant specifications, refer to the following table.
Coolant Conditioner	Subaru Coolant Conditioner SOA635071	—
Brake fluid	DOT3 or DOT4	FMVSS NO. 116 Avoid mixing brake fluid of different brands to prevent the fluid performance from degrading. When brake fluid is added, be careful not to allow any dust into the reservoir.
Clutch fluid	DOT3 or DOT4	FMVSS NO. 116 Avoid mixing brake fluid of different brands to prevent the fluid performance from degrading. When clutch fluid is added, be careful not to allow any dust into the reservoir.

Lubricants	Recommended	Application	Equivalent
Spray lubricants	SUBARU CRC (P/N 004301003)	O ₂ sensor	—
Grease	SUNLIGHT 2 N: glube R (P/N 003602010)	Steering shaft bearing, bushing for manual transmission gear shift system	—
	Valiant grease M-2 (P/N 003608001)	Steering gearbox	—
	Niglube RX-2 (P/N 003606000 or 725191040)	Piston boot of disc brake and sliding pin	—
	Molykote No. 7439 (P/N 725191460)	Contacting surfaces of drum brake shoes and shoe clearance adjuster	—
	Molylex No.2 (P/N 723223010)	Rear BJ joints of axle shafts	—
	VU-3A702 (P/N 23223GA050)	Rear DOJ joints of axle shafts	—
	NTG2218 (CP/N 28093AA020)	BJ (for front axle) joints of axle shafts	—
	FX clutch grease (P/N 000040901)	Splines of transmission main shaft	—
	Slicolube G-30M (P/N 004404002)	Control cables and throttle linkages subject to cold weather, water-pump impeller, door latch, striker, battery terminals, etc.	—
	SSG-6003 (P/N 28093TA000)	SFJ joints of axle shafts	—
Molykote AS-880N (P/N 26298AC000)	Contacting surfaces of brake pad and inner shim	—	

E: COOLANT

CAUTION:

- Avoid using any coolant or only water other than this designated type to prevent corrosion.
- SUBARU's engine is aluminum alloy, and so special care is necessary.
- To prevent cooling system leaks, always add Genuine Subaru Cooling System Conditioner (Part No. SOA635071) whenever the coolant is replaced.

Coolant Specifications							
Lowest anticipated atmospheric temperature	SUBARU coolant-to-water ratio (Volume) %	Specification gravity					Freezing point
		at 10°C (50°F)	at 20°C (68°F)	at 30°C (86°F)	at 40°C (104°F)	at 50°C (122°F)	
Above -30°C (-22°F)	50 — 50	1.084	1.079	1.074	1.068	1.062	-36°C (-33°F)
Above -15°C (-22°F)	30 — 70	1.053	1.049	1.044	1.039	1.034	-16°C (-3°F)

*: It is recommended that distilled water be used.

F: SEALANTS

	Recommended	Application	Equivalent
Sealant	Three Bond 1105 (P/N 004403010)	Rear differential oil drain plug, bearing cap (#5), etc.	Dow Corning's No. 7038
	Three Bond 1215 (P/N 004403007)	Matching surface of oil pump, transmission case, etc. Flywheel and drive plate tightening bolts, etc.	Dow Corning's No. 7038
	Starcalking B-33A (P/N 000018901)	Sealing against water and dust entry through weatherstrips, grommets, etc.	Butyl Rubber Sealant
	Three Bond 1217B	Matching surface of transmission oil pan	—
	Three Bond 1102 (P/N 004403006)	Steering gear box adjust screw	—
	Three Bond 1280B	Matching surface of engine cam cap	—

G: ADHESIVES

Adhesive	Cemedine 5430L	Weatherstrips and other rubber parts, plastics and textiles except soft vinyl parts.	3M's EC-1770 EC-1368
	Cemedine 540	Soft vinyl parts, and other parts subject to gasoline, grease or oil, e.g. trim leather, door inner remote cover, etc.	3M's EC-776 EC-847 EC-1022 (Spray Type)
	Cemedine 3000	Bonding metals, glass, plastic and rubber parts. Repairing slightly torn weatherstrips, etc.	Armstrong's Eastman 910
	Essex Chemical Crop's Urethane E	Windshield to body panel.	Sunstar 580

6. Replace Engine Coolant and Inspect Cooling System, Hoses and Connections

MAINTENANCE INTERVAL																	
[Number of months or km (miles), whichever occurs first]																	
Months	3	7.5	15	22.5	30	37.5	45	52.5	60	67.5	75	82.5	90	97.5	105	112.5	120
1,000 km	4.8	12	24	36	48	60	72	84	96	108	120	132	144	156	168	180	192
1,000 miles	3	7.5	15	22.5	30	37.5	45	52.5	60	67.5	75	82.5	90	97.5	105	112.5	120
					P				P				P				P

A: REPLACEMENT

1. REPLACEMENT OF COOLANT

WARNING: The radiator is of the pressurized type. Do not attempt to open the radiator cap immediately after the engine has been stopped.

- 1) Lift up the vehicle.
- 2) Remove undercover.
- 3) Fit vinyl tube to drain pipe.

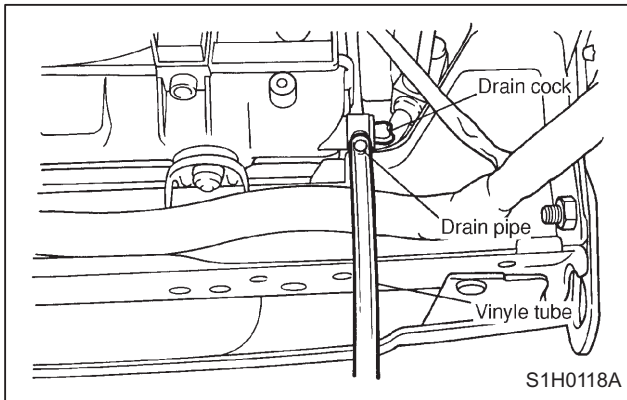

- 4) Place a container under vinyl tube.
- 5) Loosen drain cock to drain engine coolant into container.
- 6) For quick draining, open radiator cap.

CAUTION:

Be careful not to spill coolant on the floor

- 7) Drain coolant from reservoir tank.
- 8) Tighten radiator drain plug securely after draining coolant. (Drain tube may face downward.)

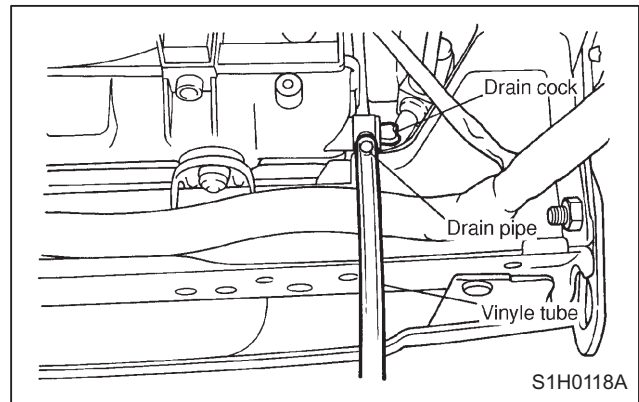

- 9) Fill engine coolant into radiator up to filler neck position.
- 10) Fill engine coolant into reservoir tank up to "FULL" level.

Coolant capacity (fill up to "FULL" level)
Approx. 6.0ℓ (6.3 US qt, 5.3 Imp qt)

CAUTION: The SUBARU Genuine Coolant containing anti-freeze and anti-rust agents is especially made for SUBARU engine, which has an aluminum crankcase. Always use SUBARU Genuine Coolant, since other coolants may cause corrosion. To prevent cooling system leaks, always add Genuine Subaru Cooling System Conditioner (Part No. SOA635071) whenever the coolant is replaced.

- 11) Securely install radiator cap and reservoir tank cap.
- 12) Run engine for more than five minutes at 2,000 to 3,000 rpm. (Run engine until radiator becomes hot in order to purge air trapped in cooling system.)
- 13) Stop engine and wait until coolant temperature lowers. Then open radiator cap to check coolant level and add coolant up to radiator fill-

B: FILLING OF ENGINE COOLANT

1) Fill engine coolant into radiator up to filler neck position.

Coolant capacity (fill up to "FULL" level):

MT model;

Approx. 6.0ℓ (6.3 US qt, 5.3 Imp qt)

AT model;

Approx. 6.2ℓ (6.6 US qt, 5.5 Imp qt)

CAUTION: The SUBARU Genuine Coolant containing antifreeze and anti-rust agents is especially made for SUBARU engine, which has an aluminum crankcase. Always use SUBARU Genuine Coolant, since other coolant may cause corrosion. To prevent cooling system leaks, always add Genuine Subaru Cooling System Conditioner (Part No. SOA635071) whenever the coolant is replaced.

2) Fill engine coolant into reservoir tank up to upper level.

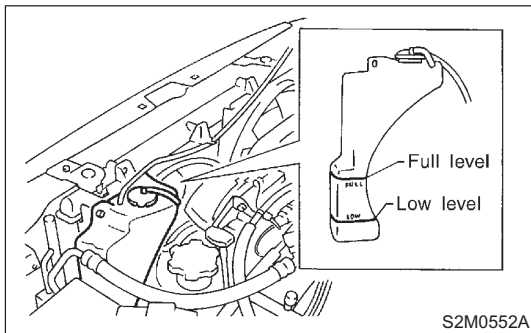

- 3) Attach radiator cap and reservoir tank cap properly.
- 4) Warm-up engine completely for more than five minutes at 2,000 to 3,000 rpm.
- 5) If engine coolant level drops in radiator, add engine coolant to filler neck position.
- 6) If engine coolant level drops from upper level of reservoir tank, add engine coolant to upper level.
- 7) Attach radiator cap and reservoir tank cap properly.

1. RELATIONSHIP OF SUBARU COOLANT CONCENTRATION AND FREEZING TEMPERATURE

The concentration and safe operating temperature of the SUBARU coolant is shown in the diagram. Measuring the temperature and specific gravity of the coolant will provide this information.

[Example]

If the coolant temperature is 25°C (77°F) and its specific gravity is 1.054, the concentration is 35% (point A), the safe operating temperature is -14°C (7°F) (point B), and the freezing temperature is -20°C (-4°F) (point C).

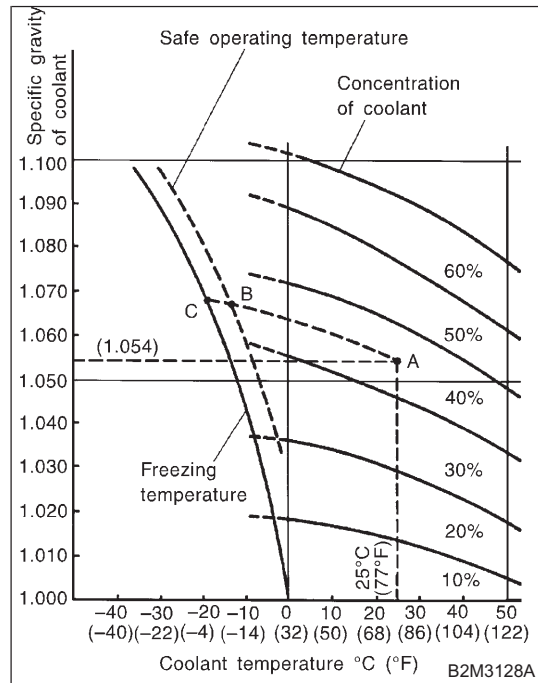

C: LUBRICANTS

Lubricants	Specifications	Remarks
Engine oil	API Classification: SJ or SH with the words "Energy Conserving II" New API Certified CCMC Specification: G4 or G5 ACEA Specification: A1, A2 or A3	For SAE viscosity number, refer to the following table. If it is impossible to get SJ or SH grade, you may use SG grade.
Transmission and differential gear oil AWD rear differential gear oil	API Classification: GL-5	For SAE viscosity number, refer to the following table.
Automatic transmission	"DEXRON II, IIE" or "DEXRON III" type	—
Power steering fluid	"DEXRON II, IIE" or "DEXRON III" type	—
Coolant	Genuine SUBARU Coolant (Part No. 000016218) (Anti-freeze, anti-corrosive ethylene glycol base)	For further coolant specifications, refer to the following table.
Coolant Conditioner	Subaru Coolant Conditioner SOA635071	—
Brake fluid	DOT3 or DOT4	FMVSS NO. 116 Avoid mixing brake fluid of different brands to prevent the fluid performance from degrading. When brake fluid is added, be careful not to allow any dust into the reservoir.
Clutch fluid	DOT3 or DOT4	FMVSS NO. 116 Avoid mixing brake fluid of different brands to prevent the fluid performance from degrading. When clutch fluid is added, be careful not to allow any dust into the reservoir.

Lubricants	Recommended	Application	Equivalent
Spray lubricants	SUBARU CRC (P/N 004301003)	O ₂ sensor	—
Grease	SUNLIGHT 2 N: glube R (P/N 003602010)	Steering shaft bearing, bushing for manual transmission gear shift system	—
	Valiant grease M-2 (P/N 003608001)	Steering gearbox	—
	Niglube RX-2 (P/N 003606000 or 725191040)	Piston boot of disc brake and sliding pin	—
	Molykote No. 7439 (P/N 725191460)	Contacting surfaces of drum brake shoes and shoe clearance adjuster	—
	Molylex No.2 (P/N 723223010)	BJ of rear axle shafts	—
	VU-3A702 (P/N 23223GA050)	DOJ of rear axle shafts	—
	NTG2218 (CP/N 28093AA020)	BJ of front axle shafts	—
	SSG-6003 (P/N 28093TA000)	SFJ of front axle shaft	—
	FX clutch grease (P/N 000040901)	Splines of transmission main shaft	—
	Slicolube G-30M (P/N 004404002)	Control cables and throttle linkages subject to cold weather, water-pump impeller, door latch, striker, battery terminals, etc.	—
	Slicolube G-40M (P/N 004404003)	Clutch master cylinder push rod end	—
Molykote AS-880N (P/N 26298AC000)	Contacting surfaces of brake pad and inner shim	—	

E: COOLANT

CAUTION:

- Avoid using any coolant or only water other than this designated type to prevent corrosion.
- SUBARU's engine is aluminum alloy, and so special care is necessary.
- To prevent cooling system leaks, always add Genuine Subaru Cooling System Conditioner (Part No. SOA635071) whenever the coolant is replaced.

Coolant Specifications							
Lowest anticipated atmospheric temperature	SUBARU coolant-to-*water ratio (Volume) %	Specification gravity					Freezing point
		at 10°C (50°F)	at 20°C (68°F)	at 30°C (86°F)	at 40°C (104°F)	at 50°C (122°F)	
Above -30°C (-22°F)	50 — 50	1.084	1.079	1.074	1.068	1.062	-36°C (-33°F)
Above -15°C (5°F)	30 — 70	1.053	1.049	1.044	1.039	1.034	-16°C (3°F)

*: It is recommended that distilled water be used.

F: SEALANTS

	Recommended	Application	Equivalent
Sealant	Three Bond 1105 (P/N 004403010)	Rear differential oil drain plug, retainer bolt, etc.	Dow Corning's No. 7038
	Three Bond 1215 (P/N 004403007)	Matching surface of oil pump, transmission case, etc. Flywheel and drive plate tightening bolts, etc.	Dow Corning's No. 7038
	Starcalking B-33A (P/N 000018901)	Sealing against water and dust entry through weatherstrips, grommets, etc.	Butyl Rubber Sealant
	Three Bond 1102 (P/N 004403006)	Steering gear box adjust screw	—

G: ADHESIVES

Adhesive	Cemedine 5430L	Weatherstrips and other rubber parts, plastics and textiles except soft vinyl parts.	3M's EC-1770 EC-1368
	Cemedine 540	Soft vinyl parts, and other parts subject to gasoline, grease or oil, e.g. trim leather, door inner remote cover, etc.	3M's EC-776 EC-847 EC-1022 (Spray Type)
	Cemedine 3000	Bonding metals, glass, plastic and rubber parts. Repairing slightly torn weatherstrips, etc.	Armstrong's Eastman 910
	Essex Chemical Crop's Urethane E	Windshield to body panel.	Sunstar 580

6. Replace Engine Coolant and Inspect Cooling and Heating System, Hoses and Connections

MAINTENANCE INTERVAL																	
[Number of months or km (miles), whichever occurs first]																	
Months	3	7.5	15	22.5	30	37.5	45	52.5	60	67.5	75	82.5	90	97.5	105	112.5	120
x 1,000 km	4.8	12	24	36	48	60	72	84	96	108	120	132	144	156	168	180	192
x 1,000 miles	3	7.5	15	22.5	30	37.5	45	52.5	60	67.5	75	82.5	90	97.5	105	112.5	120
					P				P				P				P

A: REPLACEMENT

1. REPLACEMENT OF COOLANT

WARNING:

The radiator is of the pressurized type. Do not attempt to open the radiator cap immediately after the engine has been stopped.

- 1) Lift up the vehicle.
- 2) Fit vinyle tube to drain pipe.

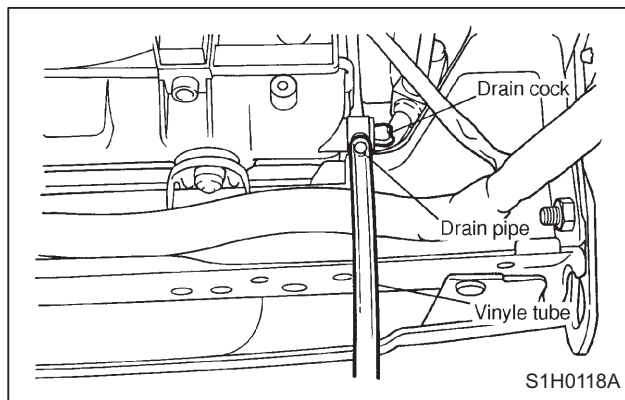

- 3) Place a container under vinyle tube.
- 4) Loosen drain cock to drain engine coolant into container.
- 5) For quick draining, open radiator cap.

CAUTION:

Be careful not to spill coolant on the floor.

- 6) Drain coolant from reservoir tank.
- 7) Tighten radiator drain cock securely after draining coolant. (Drain tube may face downward.)

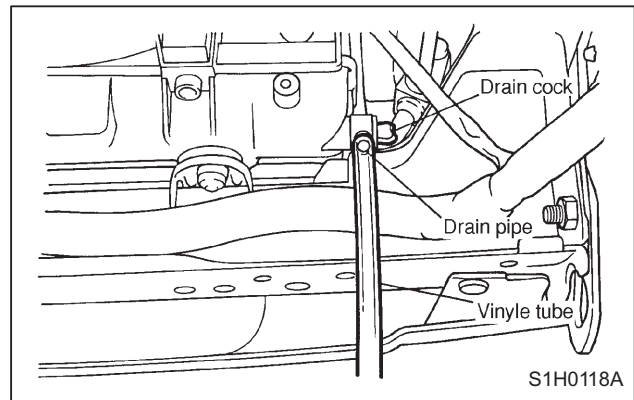

- 8) Fill engine coolant into radiator up to filler neck position.
- 9) Fill engine coolant into reservoir tank up to "FULL" level.

Coolant capacity (fill up to "FULL" level)
Approx. 6.2 l (6.6 US qt, 5.5 Imp qt)

CAUTION: The SUBARU Genuine Coolant containing anti-freeze and anti-rust agents is especially made for SUBARU engine, which has an aluminum crankcase. Always use SUBARU Genuine Coolant, since other coolants may cause corrosion.

To prevent cooling system leaks, always add Genuine Subaru Cooling System Conditioner (Part No. SOA635071) whenever the coolant is replaced.

- 10) Securely install radiator cap and reservoir tank cap.
- 11) Run engine for more than five minutes at 2,000 to 3,000 rpm. (Run engine until radiator becomes hot in order to purge air trapped in cooling system.)
- 12) Stop engine and wait until coolant temperature lowers. Then open radiator cap to check coolant level and add coolant up to radiator fill-

9. Engine Coolant

A: DRAINING OF ENGINE COOLANT

WARNING:

The radiator is pressurized. Wait until engine cools down before working on the radiator.

- 1) Lift-up the vehicle.
- 2) Remove under cover.
- 3) Fit vinyl tube to drain pipe.

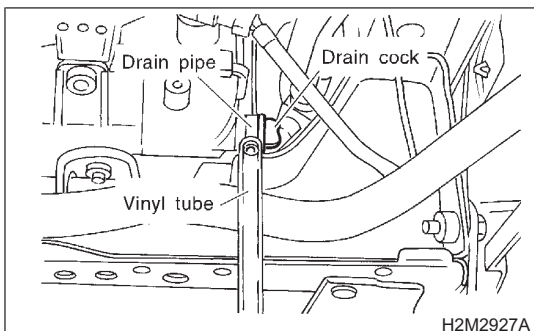

- 4) Loosen drain cock to drain engine coolant into container.

NOTE:

Remove radiator cap so that engine coolant will drain faster.

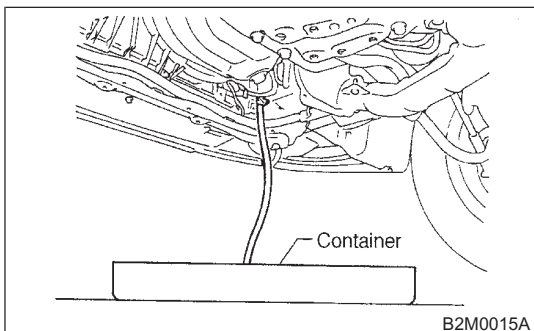

B: FILLING OF ENGINE COOLANT

- 1) Fill engine coolant into radiator up to filler neck position.

Coolant capacity (fill up to "FULL" level):
Approx. 6.2ℓ (6.6 US qt, 5.5 Imp qt)

CAUTION: The SUBARU Genuine Coolant containing antifreeze and anti-rust agents is especially made for SUBARU engine, which has an aluminum crankcase. Always use SUBARU Genuine Coolant, since other coolant may cause corrosion.

To prevent cooling system leaks, always add Genuine Subaru Cooling System Conditioner (Part No. SOA635071) whenever the coolant is replaced.

- 2) Fill engine coolant into reservoir tank up to upper level.

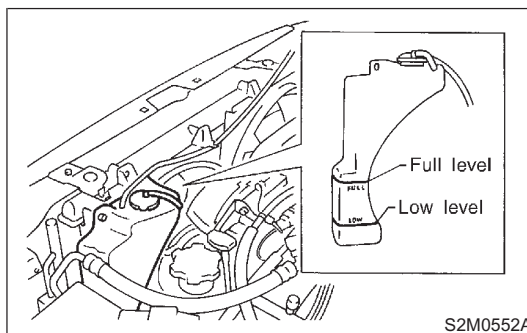

- 3) Attach radiator cap and reservoir tank cap properly.
- 4) Warm-up engine completely for more than five minutes at 2,000 to 3,000 rpm.
- 5) If engine coolant level drops in radiator, add engine coolant to filler neck position.
- 6) If engine coolant level drops from upper level of reservoir tank, add engine coolant to upper level.
- 7) Attach radiator cap and reservoir tank cap properly.

1. RELATIONSHIP OF SUBARU COOLANT CONCENTRATION AND FREEZING TEMPERATURE

The concentration and safe operating temperature of the SUBARU coolant is shown in the diagram. Measuring the temperature and specific gravity of the coolant will provide this information.

C: LUBRICANTS

Lubricants	Specifications	Remarks
Engine oil	API Classification: SJ or SH with the words "Energy Conserving II" New API Certified CCMC Specification: G4 or G5 ACEA Specification: A1, A2 or A3	For SAE viscosity number, refer to the following table. If it is impossible to get SJ or SH grade, you may use SG grade.
Transmission and differential gear oil AWD rear differential gear oil	API Classification: GL-5	For SAE viscosity number, refer to the following table.
Automatic transmission fluid	DEXRON II, IIE or III type	—
Power steering fluid	DEXRON II, IIE or III type	—
Coolant	Genuine SUBARU Coolant (Part No. 000016218) (Anti-freeze, anti-corrosive ethylene glycol base)	For further coolant specifications, refer to the following table.
Coolant Conditioner	Subaru Coolant Conditioner SOA635071	—
Brake fluid	DOT3 or DOT4	FMVSS No. 116 Avoid mixing brake fluid of different brands to prevent the fluid performance from degrading. When brake fluid is added, be careful not to allow any dust into the reservoir.
Clutch fluid	DOT3 or DOT4	FMVSS No. 116 Avoid mixing brake fluid of different brands to prevent the fluid performance from degrading. When clutch fluid is added, be careful not to allow any dust into the reservoir.

Lubricants	Recommended	Application	Equivalent
Spray lubricants	SUBARU CRC (P/N 004301003)	O ₂ sensor	—
Grease	SUNLIGHT 2 (P/N 003602010)	Steering shaft bearing, bushing for manual transmission gear shift system	—
	Valiant grease M-2 (P/N 003608001)	Steering gearbox	—
	Niglube RX-2 (P/N 003606000 or 725191040)	Piston boot of disc brake and sliding pin	—
	Molykote No. 7439 (P/N 725191460)	Contacting surfaces of drum brake shoes and shoe clearance adjuster	—
	Molylex No.2 (P/N 723223010)	BJ of rear axle shaft	—
	VU-3A702 (P/N 23223GA050)	DOJ of rear axle shaft	—
	NTG2218 (P/N 28093AA000)	BJ of front axle shaft	—
	SSG-6003 (P/N 28093TA000)	SFJ of front axle shafts	—
	FX clutch grease (P/N 000040901)	Splines of transmission main shaft	—
	Slicolube G-30M (P/N 004404002)	Control cables and throttle linkages subject to cold weather, water-pump impeller, door latch, striker, battery terminals, etc.	—
	Slicolube G-40M (P/N 004404003)	Clutch master cylinder push rod end	—
Molykote AS-880N (P/N 26298AC000)	Contacting surfaces of brake pad and shoe inner shim	—	

E: COOLANT

CAUTION: Avoid using any coolant or only water other than this designated type to prevent corrosion. SUBARU's engine is aluminum alloy, and so special care is necessary. To prevent cooling system leaks, always add Genuine Subaru Cooling System Conditioner (Part No. SOA635071) whenever the coolant is replaced.

Coolant Specifications							
Lowest anticipated atmospheric temperature	SUBARU coolant-to-*water ratio (Volume) %	Specification gravity					Freezing point
		at 10°C (50°F)	at 20°C (68°F)	at 30°C (86°F)	at 40°C (104°F)	at 50°C (122°F)	
Above -30°C (-22°F)	50 — 50	1.084	1.079	1.074	1.068	1.062	-36°C (-33°F)
Above -15°C (5°F)	30 — 70	1.050	1.049	1.042	1.037	1.032	-16°C (3°F)

*: It is recommended that distilled water be used.

F: SEALANTS

	Recommended	Application	Equivalent
Sealant	Three Bond 1105 (P/N 004403010)	Rear differential oil drain plug, retainer bolts, etc.	Dow Corning's No. 7038
	Three Bond 1215 (P/N 004403007)	Matching surface of oil pump, oil pan, oil pressure switch, transmission case, etc. Flywheel and drive plate tightening bolts, etc.	Dow Corning's No. 7038
	Starcalking B-33A (P/N 000018901)	Sealing against water and dust entry through weatherstrips, grommets, etc.	Butyl Rubber Sealant
	Three Bond 1102 (P/N 004403006)	Steering gear box adjust screw	—
	Three Bond 1280B	Matching surface of SOHC engine cam cap	—

G: ADHESIVES

Adhesive	Cemedine 5430L	Weatherstrips and other rubber parts, plastics and textiles except soft vinyl parts.	3M's EC-1770 EC-1368
	Cemedine 540	Soft vinyl parts, and other parts subject to gasoline, grease or oil, e.g. trim leather, door inner remote cover, etc.	3M's EC-776 EC-847 EC-1022 (Spray Type)
	Cemedine 3000	Bonding metals, glass, plastic and rubber parts. Repairing slightly torn weatherstrips, etc.	Armstrong's Eastman 910
	Essex Chemical Crop's Urethane E	Windshield to body panel.	Sunstar 580

6. Replace Engine Coolant and Inspect Cooling System, Hoses and Connections

MAINTENANCE INTERVAL																	
[Number of months or km (miles), whichever occurs first]																	
Months	3	7.5	15	22.5	30	37.5	45	52.5	60	67.5	75	82.5	90	97.5	105	112.5	120
x 1,000 km	4.8	12	24	36	48	60	72	84	96	108	120	132	144	156	168	180	192
x 1,000 miles	3	7.5	15	22.5	30	37.5	45	52.5	60	67.5	75	82.5	90	97.5	105	112.5	120
					P				P				P				P

A: REPLACEMENT

1. REPLACEMENT OF COOLANT

WARNING:

The radiator is of the pressurized type. Do not attempt to open the radiator cap immediately after the engine has been stopped.

- 1) Lift up the vehicle.
- 2) Remove under cover.
- 3) Place a container under drain pipe.
- 4) Loosen and remove drain screw (A) to drain engine coolant into container.

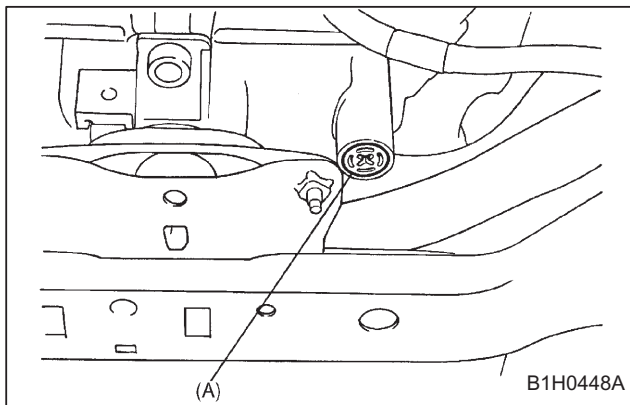

- 5) For quick draining, open radiator cap.

CAUTION:

Be careful not to spill coolant on the floor.

- 6) Drain coolant from reservoir tank.
- 7) Tighten radiator drain screw securely after draining coolant.
- 8) Slowly pour prepared coolant from radiator filler port to neck of filler, then pour into reservoir tank up to "FULL" level.

Coolant capacity (fill up to "FULL" level)

MT model:

Approx. 6.8ℓ (7.2 US qt, 6.0 Imp qt)

AT model:

Approx. 6.7ℓ (7.1 US qt, 5.9 Imp qt)

CAUTION: The SUBARU Genuine Coolant containing anti-freeze and anti-rust agents is especially made for SUBARU engine, which has an aluminum crankcase. Always use SUBARU Genuine Coolant, since other coolant may cause corrosion. To prevent cooling system leaks, always add Genuine Subaru Cooling System Conditioner (Part No. SOA635071) whenever the coolant is replaced.

- 9) Securely install radiator cap.
- 10) Run engine for more than five minutes at 2,000 to 3,000 rpm. (Run engine until radiator becomes hot in order to purge air trapped in cooling system.)
- 11) Stop engine and wait until coolant temperature lowers. Then open radiator cap to check coolant level and add coolant up to radiator filler neck. Next, add coolant into reservoir tank up to "FULL" level.
- 12) After adding coolant, securely install radiator and reservoir tank caps.

2. RELATIONSHIP OF SUBARU COOLANT CONCENTRATION AND FREEZING TEMPERATURE

The concentration and safe operating temperature of the SUBARU coolant is shown in the diagram. Measuring the temperature and specific gravity of the coolant will provide this information.

[Example]

If the coolant temperature is 25°C (77°F) and its specific gravity is 1.054, the concentration is 35% (point A), the safe operating temperature

9. Engine Coolant

A: DRAINING OF ENGINE COOLANT

- 1) Lift-up the vehicle.
- 2) Remove under cover.

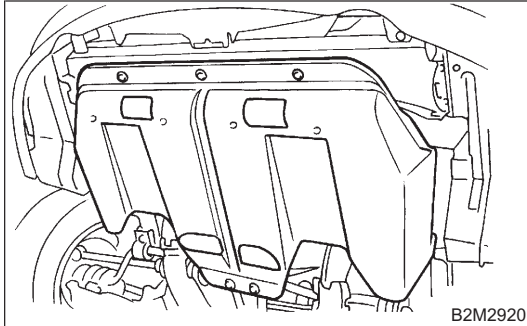

- 3) Remove drain cock to drain engine coolant into container.

NOTE:

Remove radiator cap so that engine coolant will drain faster.

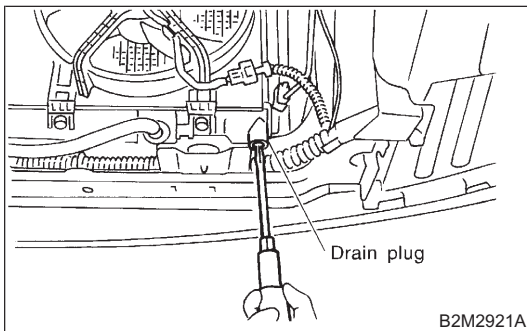

B: FILLING OF ENGINE COOLANT

- 1) Fill engine coolant into radiator up to filler neck position.

Coolant capacity (fill up to "FULL" level):

MT model;

Approx. 6.4ℓ (6.8 US qt, 5.6 Imp qt)

AT model;

Approx. 6.3ℓ (6.7 US qt, 5.5 Imp qt)

CAUTION: The SUBARU Genuine Coolant containing antifreeze and anti-rust agents is especially made for SUBARU engine, which has an aluminum crankcase. Always use SUBARU Genuine Coolant, since other coolant may cause corrosion. To prevent cooling system leaks, always add Genuine Subaru Cooling System Conditioner (Part No. SOA635071) whenever the coolant is replaced.

- 2) Fill engine coolant into reservoir tank up to upper level.

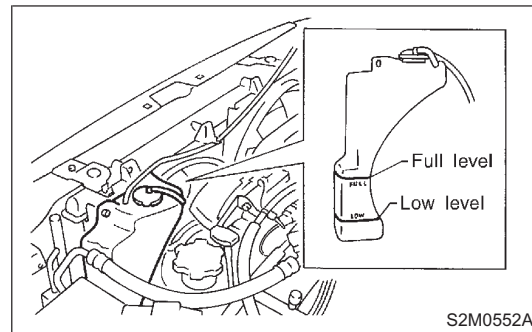

- 3) Attach radiator cap and reservoir tank cap properly.
- 4) Warm-up engine completely for more than five minutes at 2,000 to 3,000 rpm.
- 5) If engine coolant level drops in radiator, add engine coolant to filler neck position.
- 6) If engine coolant level drops from upper level of reservoir tank, add engine coolant to upper level.
- 7) Attach radiator cap and reservoir tank cap properly.

1. RELATIONSHIP OF SUBARU COOLANT CONCENTRATION AND FREEZING TEMPERATURE

The concentration and safe operating temperature of the SUBARU coolant is shown in the diagram. Measuring the temperature and specific gravity of the coolant will provide this information.

C: LUBRICANTS

Lubricants	Specifications	Remarks
Engine oil	API Classification: SJ or SH with the words "Energy Conserving II" New API Certified CCMC Specification: G4 or G5 ACEA Specification: A1, A2 or A3	For SAE viscosity number, refer to the following table. If it is impossible to get SJ or SH grade, you may use SG grade.
Transmission and differential gear oil AWD rear differential gear oil	API Classification: GL-5	For SAE viscosity number, refer to the following table.
Automatic transmission	"DEXRON II, IIE" or "DEXRON III" type	—
Power steering fluid	"DEXRON II, IIE" or "DEXRON III" type	—
Coolant	Genuine SUBARU Coolant (Part No. 000016218) (Anti-freeze, anti-corrosive ethylene glycol base)	For further coolant specifications, refer to the following table.
Coolant Conditioner	Subaru Coolant Conditioner SOA635071	—
Brake fluid	DOT3 or DOT4	FMVSS NO. 116 Avoid mixing brake fluid of different brands to prevent the fluid performance from degrading. When brake fluid is added, be careful not to allow any dust into the reservoir.
Clutch fluid	DOT3 or DOT4	FMVSS NO. 116 Avoid mixing brake fluid of different brands to prevent the fluid performance from degrading. When clutch fluid is added, be careful not to allow any dust into the reservoir.

Lubricants	Recommended	Application	Equivalent
Spray lubricants	SUBARU CRC (P/N 004301003)	O ₂ sensor	—
Grease	SUNLIGHT 2 N: glube R (P/N 003602010)	Steering shaft bearing, bushing for manual transmission gear shift system	—
	Valiant grease M-2 (P/N 003608001)	Steering gearbox	—
	Niglube RX-2 (P/N 003606000 or 725191040)	Piston boot of disc brake and sliding pin	—
	Molykote No. 7439 (P/N 725191460)	Contacting surfaces of drum brake shoes and shoe clearance adjuster	—
	Molylex No.2 (P/N 723223010)	Rear BJ joints of axle shafts	—
	VU-3A702 (P/N 23223GA050)	Rear DOJ joints of axle shafts	—
	NTG2218 (CP/N 28093AA020)	BJ (for front axle) joints of axle shafts	—
	FX clutch grease (P/N 000040901)	Splines of transmission main shaft	—
	Slicolube G-30M (P/N 004404002)	Control cables and throttle linkages subject to cold weather, water-pump impeller, door latch, striker, battery terminals, etc.	—
	SSG-6003 (P/N 28093TA000)	SFJ joints of axle shafts	—
Molykote AS-880N (P/N 26298AC000)	Contacting surfaces of brake pad and inner shim	—	

6. Replace Engine Coolant and Inspect Cooling System, Hoses and Connections

MAINTENANCE INTERVAL																	
[Number of months or km (miles), whichever occurs first]																	
Months	3	7.5	15	22.5	30	37.5	45	52.5	60	67.5	75	82.5	90	97.5	105	112.5	120
x 1,000 km	4.8	12	24	36	48	60	72	84	96	108	120	132	144	156	168	180	192
x 1,000 miles	3	7.5	15	22.5	30	37.5	45	52.5	60	67.5	75	82.5	90	97.5	105	112.5	120
					P				P				P				P

A: REPLACEMENT

1. REPLACEMENT OF COOLANT

WARNING:

The radiator is of the pressurized type. Do not attempt to open the radiator cap immediately after the engine has been stopped.

- 1) Lift up the vehicle.
- 2) Remove undercover.
- 3) Fit vinyle tube to drain pipe.

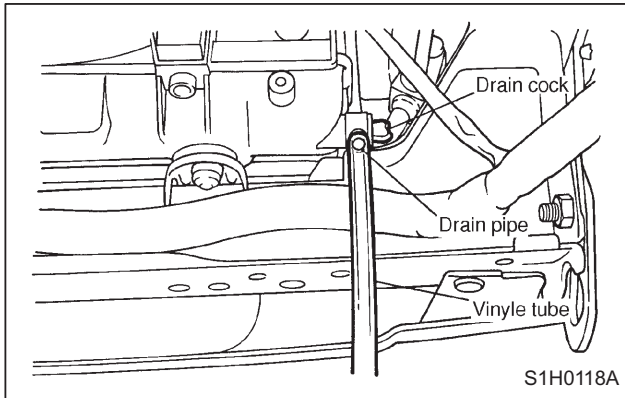

- 4) Place a container under vinyle tube.
- 5) Loosen drain cock to drain engine coolant into container.
- 6) For quick draining, open radiator cap.

CAUTION:

Be careful not to spill coolant on the floor.

- 7) Drain coolant from reservoir tank.
- 8) Tighten radiator drain plug securely after draining coolant. (Drain tube may face downward.)

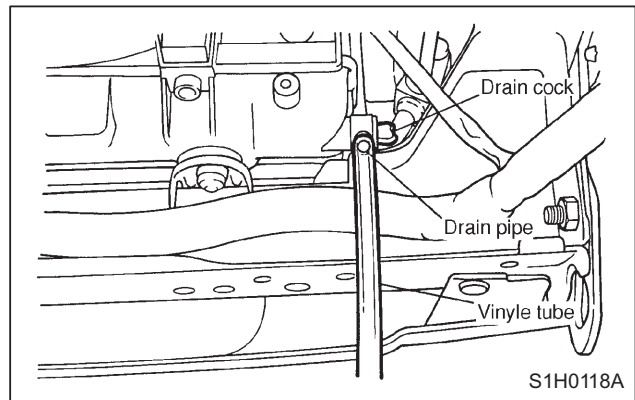

- 9) Fill engine coolant into radiator up to filler neck position.
- 10) Fill engine coolant into reservoir tank up to "FULL" level.

Coolant capacity (fill up to "FULL" level)
Approx. 6.0 l (6.3 US qt, 5.3 Imp qt)

CAUTION: The SUBARU Genuine Coolant containing anti-freeze and anti-rust agents is especially made for SUBARU engine, which has an aluminum crankcase. Always use SUBARU Genuine Coolant, since other coolant may cause corrosion. To prevent cooling system leaks, always add Genuine Subaru Cooling System Conditioner (Part No. SOA635071) whenever the coolant is replaced.

- 11) Securely install radiator cap and reservoir tank cap.
- 12) Run engine for more than five minutes at 2,000 to 3,000 rpm. (Run engine until radiator becomes hot in order to purge air trapped in cooling system.)
- 13) Stop engine and wait until coolant temperature lowers. Then open radiator cap to check coolant level and add coolant up to radiator fill-

E: COOLANT

CAUTION: Avoid using any coolant or only water other than this designated type to prevent corrosion. SUBARU's engine is aluminum alloy, and so special care is necessary. To prevent cooling system leaks, always add Genuine Subaru Cooling System Conditioner (Part No. SOA635071) whenever the coolant is replaced.

Coolant Specifications							
Lowest anticipated atmospheric temperature	SUBARU coolant-to-*water ratio (Volume) %	Specification gravity					Freezing point
		at 10 C (50 F)	at 20 C (68 F)	at 30 C (86 F)	at 40 C (104 F)	at 50 C (122 F)	
Above -30 C (-22 F)	50 — 50	1.084	1.079	1.074	1.068	1.062	-36 C (-33 F)
Above -15 C (5 F)	30 — 70	1.053	1.049	1.044	1.039	1.034	-16 C (3 F)

*: It is recommended that distilled water be used.

F: SEALANTS

	Recommended	Application	Equivalent
Sealant	Three Bond 1105 (P/N 004403010)	Rear differential oil drain plug, bearing cap (#5), etc.	Dow Corning's No. 7038
	Three Bond 1215 (P/N 004403007)	Matching surface of oil pump, transmission case, etc. Flywheel and drive plate tightening bolts, etc.	Dow Corning's No. 7038
	Starcalking B-33A (P/N 000018901)	Sealing against water and dust entry through weatherstrips, grommets, etc.	Butyl Rubber Sealant
	Three Bond 1217B	Matching surface of transmission oil pan	—
	Three Bond 1102 (P/N 004403006)	Steering gear box adjust screw	—
	Three Bond 1280B	Matching surface of engine cam cap	—

G: ADHESIVES

Adhesive	Cemedine 5430L	Weatherstrips and other rubber parts, plastics and textiles except soft vinyl parts.	3M's EC-1770 EC-1368
	Cemedine 540	Soft vinyl parts, and other parts subject to gasoline, grease or oil, e.g. trim leather, door inner remote cover, etc.	3M's EC-776 EC-847 EC-1022 (Spray Type)
	Cemedine 3000	Bonding metals, glass, plastic and rubber parts. Repairing slightly torn weatherstrips, etc.	Armstrong's Eastman 910
	Essex Chemical Crop's Urethane E	Windshield to body panel.	Sunstar 580

B: FILLING OF ENGINE COOLANT

1) Fill engine coolant into radiator up to filler neck position.

Coolant capacity (fill up to "FULL" level):

MT model;

Approx. 6.0ℓ (6.3 US qt, 5.3 Imp qt)

AT model;

Approx. 6.2ℓ (6.6 US qt, 5.5 Imp qt)

CAUTION: The SUBARU Genuine Coolant containing antifreeze and anti-rust agents is especially made for SUBARU engine, which has an aluminum crankcase. Always use SUBARU Genuine Coolant, since other coolant may cause corrosion. To prevent cooling system leaks, always add Genuine Subaru Cooling System Conditioner (Part No. SOA635071) whenever the coolant is replaced.

2) Fill engine coolant into reservoir tank up to full level.

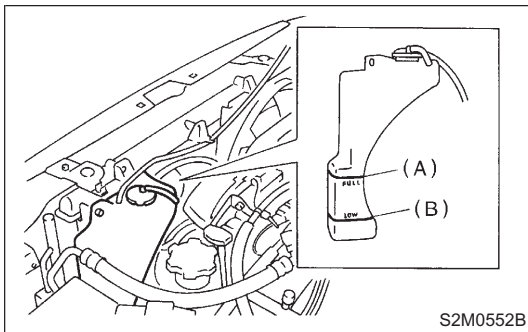

(A) Full level
(B) Low level

- 3) Attach radiator cap and reservoir tank cap properly.
- 4) Warm-up engine completely for more than five minutes at 2,000 to 3,000 rpm.
- 5) If engine coolant level drops in radiator, add engine coolant to filler neck position.
- 6) If engine coolant level drops from upper level of reservoir tank, add engine coolant to upper level.
- 7) Attach radiator cap and reservoir tank cap properly.

1. RELATIONSHIP OF SUBARU COOLANT CONCENTRATION AND FREEZING TEMPERATURE

The concentration and safe operating temperature of the SUBARU coolant is shown in the diagram. Measuring the temperature and specific gravity of the coolant will provide this information.

[Example]

If the coolant temperature is 25°C (77°F) and its specific gravity is 1.054, the concentration is 35% (point A), the safe operating temperature is -14°C (7°F) (point B), and the freezing temperature is -20°C (-4°F) (point C).

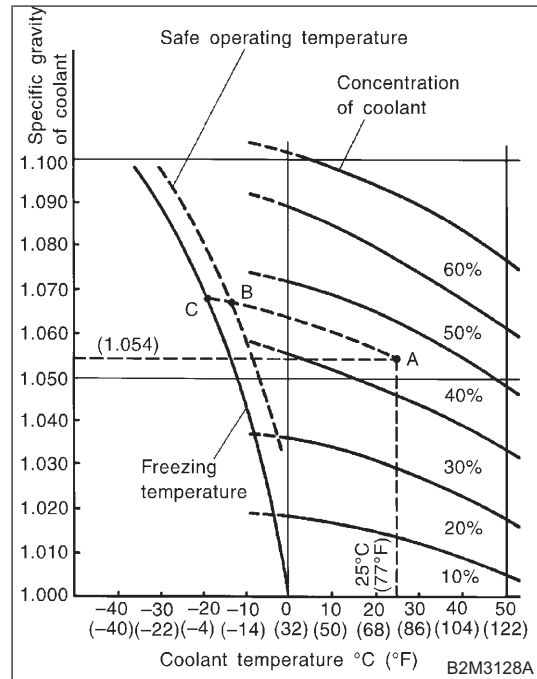

ENGINE COOLANT

Cooling

2. Engine Coolant S106060

A: REPLACEMENT S106060A20

1. DRAINING OF ENGINE COOLANT

S106060A2001

WARNING:

The radiator is pressurized. Wait until engine cools down before working on the radiator.

- 1) Lift-up the vehicle.
- 2) Remove under cover.
- 3) Fit vinyl tube to drain pipe.

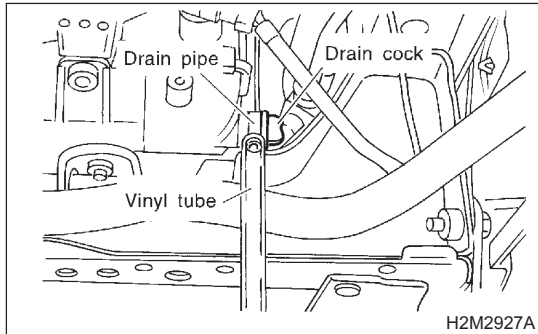

- 4) Loosen drain cock to drain engine coolant into container.

NOTE:

Remove radiator cap so that engine coolant will drain faster.

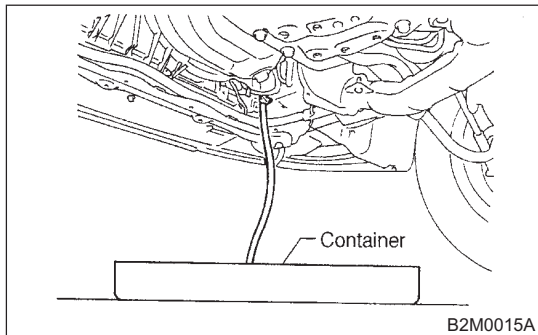

2. FILLING OF ENGINE COOLANT S106060A2002

- 1) Fill engine coolant into radiator up to filler neck position.

Coolant capacity (fill up to "FULL" level):
Approx. 6.2 (6.6 US qt, 5.5 Imp qt)

CAUTION: The SUBARU Genuine Coolant containing antifreeze and anti-rust agents is especially made for SUBARU engine, which has an aluminum crankcase. Always use SUBARU Genuine Coolant, since other coolant may cause corrosion. To prevent cooling system leaks, always add Genuine Subaru Cooling System Conditioner (Part No. SOA635071) whenever the coolant is replaced.

- 2) Fill engine coolant into reservoir tank up to upper level.

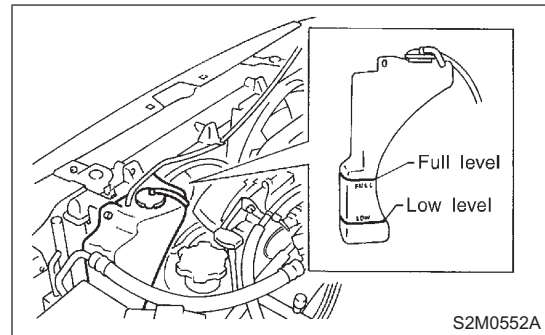

- 3) Attach radiator cap and reservoir tank cap properly.
- 4) Warm-up engine completely for more than five minutes at 2,000 to 3,000 rpm.
- 5) If engine coolant level drops in radiator, add engine coolant to filler neck position.
- 6) If engine coolant level drops from upper level of reservoir tank, add engine coolant to upper level.
- 7) Attach radiator cap and reservoir tank cap properly.

CO-6

replacement page for MSA5T0111A

13. Coolant SA07689

A: REPLACEMENT SA07689A20

1. REPLACEMENT OF COOLANT SA07689A2001

WARNING:

The radiator is of the pressurized type. Do not attempt to open the radiator cap immediately after the engine has been stopped.

- 1) Lift up the vehicle.
- 2) Remove under cover.
- 3) Place a container under drain pipe.
- 4) Fit vinyl tube to drain pipe.
- 5) Loosen drain cock to drain engine coolant into container.

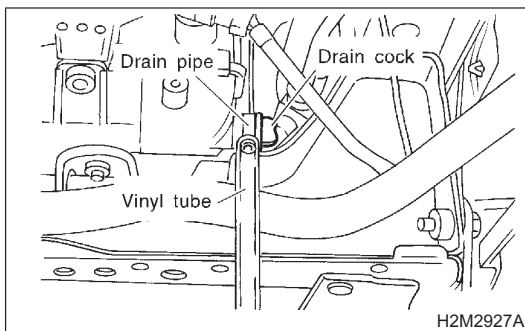

- 6) For quick draining, open radiator cap.

CAUTION:

Be careful not to spill coolant on the floor.

- 7) Drain coolant from reservoir tank.
- 8) Tighten radiator drain cock securely after draining coolant.
- 9) Slowly pour prepared coolant from radiator filler port to neck of filler, then pour into reservoir tank up to "FULL" level.

Coolant capacity (fill up to "FULL" level)
Approx. 6.2ℓ (6.6 US qt, 5.5 Imp qt)

NOTE: The SUBARU Genuine Coolant containing antifreeze and anti-rust agents is especially made for SUBARU engine, which has an aluminum crankcase. Always use SUBARU Genuine Coolant, since other coolant may cause corrosion. To prevent cooling system leaks, always add Genuine Subaru Cooling System Conditioner (Part No. SOA635071) whenever the coolant is replaced.

- 10) Securely install radiator cap.

11) Run engine for more than five minutes at 2,000 to 3,000 rpm. (Run engine until radiator becomes hot in order to purge air trapped in cooling system.)

12) Stop engine and wait until coolant temperature lowers. Then open radiator cap to check coolant level and add coolant up to radiator filler neck. Next, add coolant into reservoir tank up to "FULL" level.

- 13) After adding coolant, securely install radiator and reservoir tank caps.

2. RELATIONSHIP OF SUBARU COOLANT CONCENTRATION AND FREEZING TEMPERATURE SA07689A2002

The concentration and safe operating temperature of the SUBARU coolant is shown in the diagram. Measuring the temperature and specific gravity of the coolant will provide this information.

[Example]

If the coolant temperature is 25°C (77°F) and its specific gravity is 1.054, the concentration is 35% (point A), the safe operating temperature is -14°C (7°F) (point B), and the freezing temperature is -20°C (-4°F) (point C).

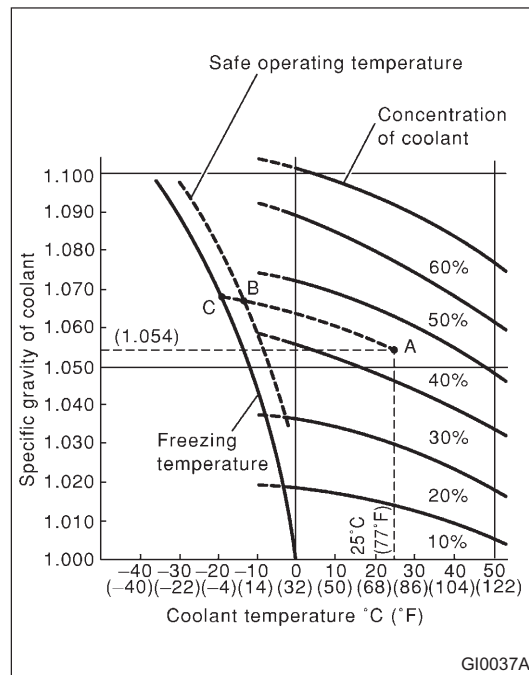

RECOMMENDED MATERIALS

Recommended Materials

SAE viscosity	SAE viscosity No. and applicable temperature SAE J300								
Manual transmission oil	(°C)	-30	-20	-10	0	10	20	30	40
	(°F)	-22	-4	14	32	50	68	86	104
								90	
								85W	
Rear differential								80W	
								75W-90	
									GI0004A
Front differential	(°C)	-30	-20	-10	0	10	20	30	40
	(°F)	-22	-4	14	32	50	68	86	104
								90	
								85W	
								80W	
								80W-90	
									GI0005A

4. FLUID SA05678G2204

Use the fluids specified in the table below. Do not mix two different kinds or makes of fluid.

Fluid	Recommended	Alternative	Remarks
Automatic transmission fluid	DEXRON III	—	—
Power steering fluid	DEXRON III	—	—
Brake fluid	FMVSS No. 116 DOT3	FMVSS No. 116 DOT4	—
Clutch fluid	FMVSS No. 116 DOT3	FMVSS No. 116 DOT4	—

5. COOLANT SA05678G2205

Use genuine coolant to protect the engine. The table below shows the ratio of coolant to distilled water.

Coolant	Recommended	Item number	Alternative
Coolant	SUBARU coolant	000016218	None
Water for dilution	Distilled water	—	Tap water
Coolant Conditioner	Subaru Coolant Conditioner	SOA635071	None

6. REFRIGERANT SA05678G2206

Standard air conditioners on Subaru vehicles use HFC134a refrigerant. Do not mix it with other refrigerants. Also, do not use any air compressor oil except for ZXL200PG.

Air conditioner	Recommended	Item number	Alternative
Refrigerant	HFC134a	—	None
Compressor oil	ZXL200PG	—	None

RM-4

replacement page for MSA5T0110A

2. Engine Coolant S106060

A: REPLACEMENT S106060A20

1. DRAINING OF ENGINE COOLANT

S106060A2001

- 1) Lift-up the vehicle.
- 2) Remove under cover.

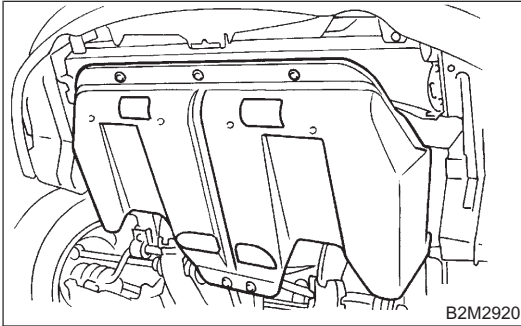

- 3) Remove drain cock to drain engine coolant into container.

NOTE:

Remove radiator cap so that engine coolant will drain faster.

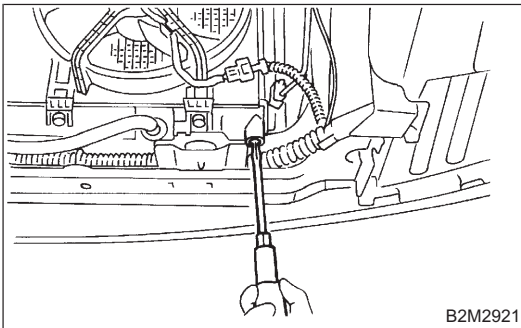

2. FILLING OF ENGINE COOLANT S106060A2002

- 1) Fill engine coolant into radiator up to filler neck position.

Coolant capacity (fill up to "FULL" level):

MT model;

Approx. 6.4 ℓ (6.8 US qt, 5.6 Imp qt)

AT model;

Approx. 6.3 ℓ (6.7 US qt, 5.5 Imp qt)

CAUTION: The SUBARU Genuine Coolant containing antifreeze and anti-rust agents is especially made for SUBARU engine, which has an aluminum crankcase. Always use SUBARU Genuine Coolant, since other coolant may cause corrosion. To prevent cooling system leaks, always add Genuine Subaru Cooling System Conditioner (Part No. SOA635071) whenever the coolant is replaced.

- 2) Fill engine coolant into reservoir tank up to upper level.

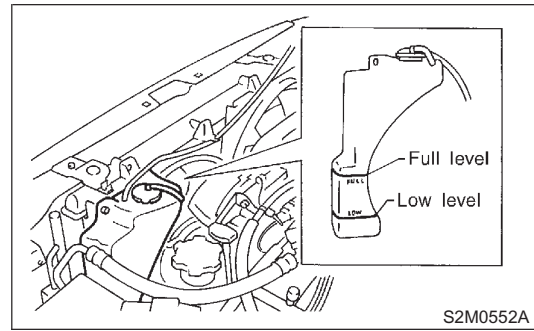

- 3) Attach radiator cap and reservoir tank cap properly.
- 4) Warm-up engine completely for more than five minutes at 2,000 to 3,000 rpm.
- 5) If engine coolant level drops in radiator, add engine coolant to filler neck position.
- 6) If engine coolant level drops from upper level of reservoir tank, add engine coolant to upper level.
- 7) Attach radiator cap and reservoir tank cap properly.

B: INSPECTION S106060A10

1. RELATIONSHIP OF SUBARU COOLANT CONCENTRATION AND FREEZING TEMPERATURE S106060A1001

The concentration and safe operating temperature of the SUBARU coolant is shown in the diagram. Measuring the temperature and specific gravity of the coolant will provide this information.

4. Engine Coolant S146060

A: REPLACEMENT S146060A20

1. DRAINING OF ENGINE COOLANT

S146060A2001

- 1) Lift-up the vehicle.
- 2) Remove under cover.

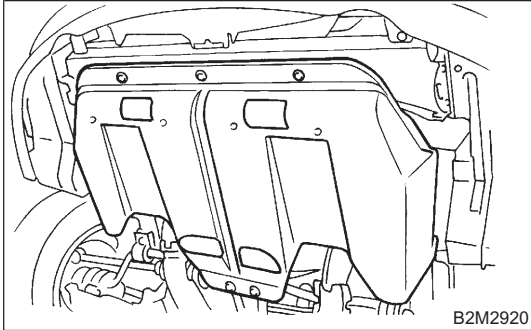

- 3) Remove drain cock to drain engine coolant into container.

NOTE:

Remove radiator cap so that engine coolant will drain faster.

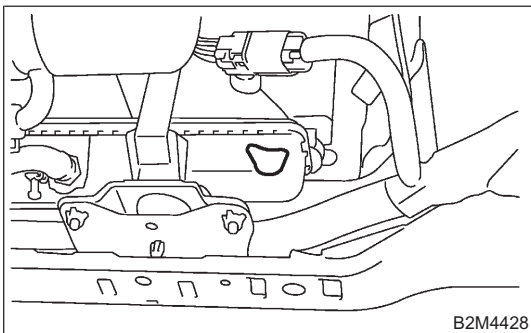

2. FILLING OF ENGINE COOLANT S146060A2002

- 1) Fill engine coolant into radiator up to filler neck position.

Coolant capacity (fill up to "FULL" level):
Approx. 7.7ℓ (8-1/8 US qt, 6-3/4 Imp qt)

CAUTION: The SUBARU Genuine Coolant containing antifreeze and anti-rust agents is especially made for SUBARU engine, which has an aluminum crankcase. Always use SUBARU Genuine Coolant, since other coolant may cause corrosion. To prevent cooling system leaks, always add Genuine Subaru Cooling System Conditioner (Part No. SOA635071) whenever the coolant is replaced.

- 2) Fill engine coolant into reservoir tank up to upper level.

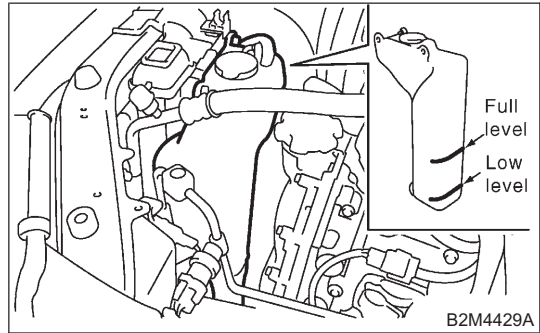

- 3) Attach radiator cap and reservoir tank cap properly.
- 4) Warm-up engine completely for more than five minutes at 2,000 to 3,000 rpm.
- 5) If engine coolant level drops in radiator, add engine coolant to filler neck position.
- 6) If engine coolant level drops from upper level of reservoir tank, add engine coolant to upper level.
- 7) Attach radiator cap and reservoir tank cap properly.

B: INSPECTION S146060A10

1. RELATIONSHIP OF SUBARU COOLANT CONCENTRATION AND FREEZING TEMPERATURE S146060A1001

The concentration and safe operating temperature of the SUBARU coolant is shown in the diagram. Measuring the temperature and specific gravity of the coolant will provide this information.

13. Coolant SA07689

A: REPLACEMENT SA07689A20

1. REPLACEMENT OF COOLANT SA07689A2001

WARNING:

The radiator is of the pressurized type. Do not attempt to open the radiator cap immediately after the engine has been stopped.

- 1) Lift up the vehicle.
- 2) Remove under cover.
- 3) Place a container under drain pipe.
- 4) Loosen and remove drain screw to drain engine coolant into container.

2.5 L model

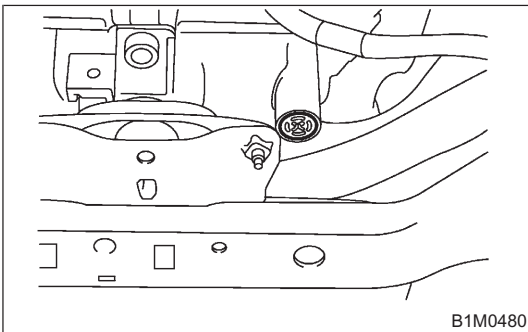

3.0 L model

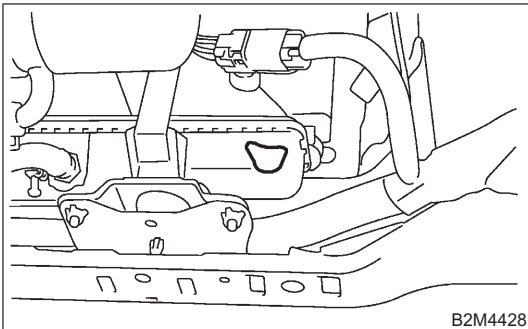

- 5) For quick draining, open radiator cap.

CAUTION:

Be careful not to spill coolant on the floor.

- 6) Drain coolant from reservoir tank.
- 7) Tighten radiator drain screw securely after draining coolant.

- 8) Slowly pour prepared coolant from radiator filler port to neck of filler, then pour into reservoir tank up to "FULL" level.

Coolant capacity (fill up to "FULL" level)

2.5 L model

MT model:

Approx. 6.8ℓ (7.2 US qt, 6.0 Imp qt)

AT model:

Approx. 6.7ℓ (7.1 US qt, 5.9 Imp qt)

3.0 L model

Approx. 7.7ℓ (8.1 US qt, 6.8 Imp qt)

NOTE: The SUBARU Genuine Coolant containing antifreeze and anti-rust agents is especially made for SUBARU engine, which has an aluminum crankcase. Always use SUBARU Genuine Coolant, since other coolant may cause corrosion. To prevent cooling system leaks, always add Genuine Subaru Cooling System Conditioner (Part No. SOA635071) whenever the coolant is replaced.

- 9) Securely install radiator cap.
- 10) Run engine for more than five minutes at 2,000 to 3,000 rpm. (Run engine until radiator becomes hot in order to purge air trapped in cooling system.)
- 11) Stop engine and wait until coolant temperature lowers. Then open radiator cap to check coolant level and add coolant up to radiator filler neck. Next, add coolant into reservoir tank up to "FULL" level.
- 12) After adding coolant, securely install radiator and reservoir tank caps.

RECOMMENDED MATERIALS

Recommended Materials

SAE viscosity	SAE viscosity No. and applicable temperature SAE J300								
Manual transmission oil	(°C)	-30	-20	-10	0	10	20	30	40
	(°F)	-22	-4	14	32	50	68	86	104
							90		
							85W		
Rear differential								80W	
								75W-90	
									GI0004A
Front differential	(°C)	-30	-20	-10	0	10	20	30	40
	(°F)	-22	-4	14	32	50	68	86	104
							90		
							85W		
								80W	
								80W-90	
									GI0005A

4. FLUID SA05678G2204

Use the fluids specified in the table below. Do not mix two different kinds or makes of fluid.

Fluid	Recommended	Alternative	Remarks
Automatic transmission fluid	DEXRON III	—	—
Power steering fluid	DEXRON III	—	—
Brake fluid	FMVSS No. 116 DOT3	FMVSS No. 116 DOT4	—
Clutch fluid	FMVSS No. 116 DOT3	FMVSS No. 116 DOT4	—

5. COOLANT SA05678G2205

Use genuine coolant to protect the engine. The table below shows the ratio of coolant to distilled water.

Coolant	Recommended	Item number	Alternative
Coolant	SUBARU coolant	000016218	None
Water for dilution	Distilled water	—	Tap water
Coolant Conditioner	Subaru Coolant Conditioner	SOA635071	None

6. REFRIGERANT SA05678G2206

Standard air conditioners on Subaru vehicles use HFC134a refrigerant. Do not mix it with other refrigerants. Also, do not use any air compressor oil except for ZXL200PG.

Air conditioner	Recommended	Item number	Alternative
Refrigerant	HFC134a	—	None
Compressor oil	ZXL200PG	—	None

RM-4

replacement page for MSA5T0109A

COOLANT

Periodic Maintenance Services

13. Coolant SA07689

A: REPLACEMENT SA07689A20

1. REPLACEMENT OF COOLANT SA07689A2001

WARNING:

The radiator is of the pressurized type. Do not attempt to open the radiator cap immediately after the engine has been stopped.

- 1) Lift up the vehicle.
- 2) Remove under cover.
- 3) Place a container under drain pipe.
- 4) Loosen and remove drain screw (A) to drain engine coolant into container.

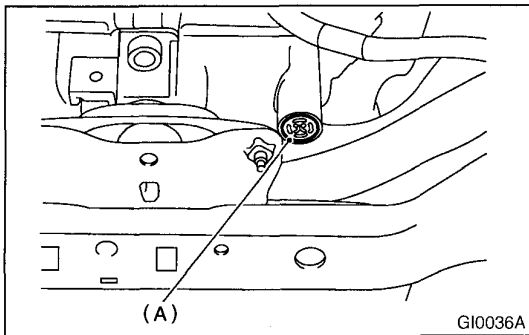

- 5) For quick draining, open radiator cap.

CAUTION:

Be careful not to spill coolant on the floor.

- 6) Drain coolant from reservoir tank.
- 7) Tighten radiator drain screw securely after draining coolant.
- 8) Slowly pour prepared coolant from radiator filler port to neck of filler, then pour into reservoir tank up to "FULL" level.

Coolant capacity (fill up to "FULL" level)

MT model:

Approx. 6.8 ℓ (7.2 US qt, 6.0 Imp qt)

AT model:

Approx. 6.7 ℓ (7.1 US qt, 5.9 Imp qt)

NOTE: The SUBARU Genuine Coolant containing antifreeze and anti-rust agents is especially made for SUBARU engine, which has an aluminum crankcase. Always use SUBARU Genuine Coolant, since other coolant may cause corrosion. To prevent cooling system leaks, always add Genuine Subaru Cooling System Conditioner (Part No. SOA635071) whenever the coolant is replaced.

- 9) Securely install radiator cap.

10) Run engine for more than five minutes at 2,000 to 3,000 rpm. (Run engine until radiator becomes hot in order to purge air trapped in cooling system.)

11) Stop engine and wait until coolant temperature lowers. Then open radiator cap to check coolant level and add coolant up to radiator filler neck. Next, add coolant into reservoir tank up to "FULL" level.

- 12) After adding coolant, securely install radiator and reservoir tank caps.

2. RELATIONSHIP OF SUBARU COOLANT CONCENTRATION AND FREEZING TEMPERATURE SA07689A2002

The concentration and safe operating temperature of the SUBARU coolant is shown in the diagram. Measuring the temperature and specific gravity of the coolant will provide this information.

[Example]

If the coolant temperature is 25°C (77°F) and its specific gravity is 1.054, the concentration is 35% (point A), the safe operating temperature is -14°C (7°F) (point B), and the freezing temperature is -20°C (-4°F) (point C).

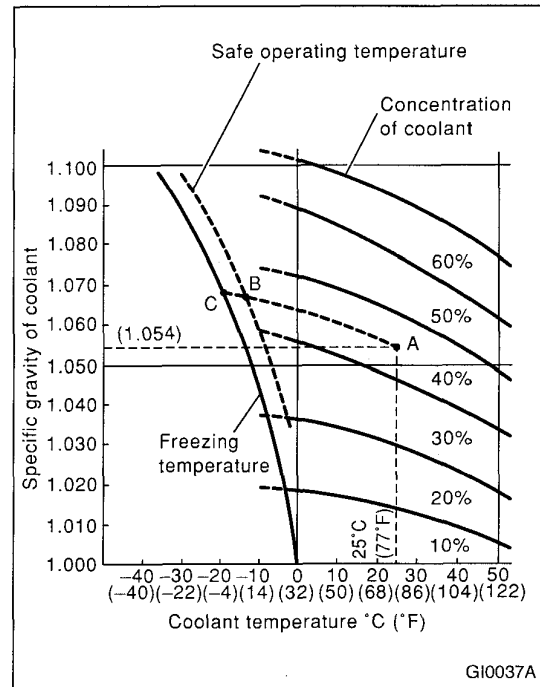

RECOMMENDED MATERIALS

Recommended Materials

SAE viscosity	SAE viscosity No. and applicable temperature SAE J300								
Manual transmission oil	(°C)	-30	-20	-10	0	10	20	30	40
	(°F)	-22	-4	14	32	50	68	86	104
							90		
						85W			
Rear differential								80W	
							75W-90		
									GI0004A
Front differential	(°C)	-30	-20	-10	0	10	20	30	40
	(°F)	-22	-4	14	32	50	68	86	104
							90		
						85W			
							80W		
						80W-90			
									GI0005A

4. FLUID SA05678G2204

Use the fluids specified in the table below. Do not mix two different kinds or makes of fluid.

Fluid	Recommended	Alternative	Remarks
Automatic transmission fluid	DEXRON III	—	
Power steering fluid	DEXRON III	—	
Brake fluid	FMVSS No. 116 DOT3	FMVSS No. 116 DOT4	
Clutch fluid	FMVSS No. 116 DOT3	FMVSS No. 116 DOT4	

5. COOLANT SA05678G2205

Use genuine coolant to protect the engine. The table below shows the ratio of coolant to distilled water.

Coolant	Recommended	Item number	Alternative
Coolant	SUBARU coolant	000016218	None
Water for dilution	Distilled water	—	Tap water
Coolant Conditioner	Subaru Coolant Conditioner	SOA635071	None

6. REFRIGERANT SA05678G2206

Standard air conditioners on Subaru vehicles use HFC134a refrigerant. Do not mix it with other refrigerants. Also, do not use any air compressor oil except for ZXL200PG.

Air conditioner	Recommended	Item number	Alternative
Refrigerant	HFC134a	—	None
Compressor oil	ZXL200PG	—	None

RM-4

replacement page for MSA5T0101A

4. Engine Coolant

A: REPLACEMENT

1. DRAINING OF ENGINE COOLANT

- 1) Lift-up the vehicle.
- 2) Remove under cover.
- 3) Remove drain cock to drain engine coolant into container.

NOTE:

Remove radiator cap so that engine coolant will drain faster.

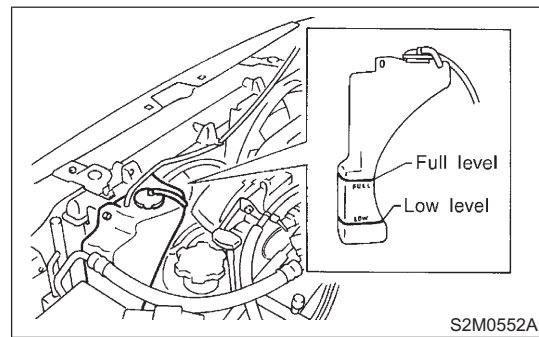
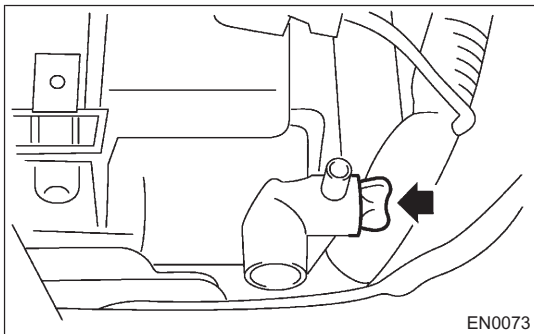

- 3) Warm-up engine completely for more than five minutes at 2,000 to 3,000 rpm.
- 4) If engine coolant level drops in radiator, add engine coolant to filler neck position.
- 5) If engine coolant level drops from upper level of reservoir tank, add engine coolant to upper level.
- 6) Attach radiator cap and reservoir tank cap properly.

B: INSPECTION

1. RELATIONSHIP OF SUBARU COOLANT CONCENTRATION AND FREEZING TEMPERATURE

The concentration and safe operating temperature of the SUBARU coolant is shown in the diagram. Measuring the temperature and specific gravity of the coolant will provide this information.

[Example]

If the coolant temperature is 25°C (77°F) and its specific gravity is 1.054, the concentration is 35% (point A), the safe operating temperature is -14°C (7°F) (point B), and the freezing temperature is -20°C (-4°F) (point C).

2. FILLING OF ENGINE COOLANT

- 1) Fill engine coolant into radiator up to filler neck position.

Coolant capacity (fill up to "FULL" level):

AT model

Approx. 6.4ℓ (6.8 US qt, 5.6 Imp qt)

MT model

Approx. 6.3ℓ (6.7 US qt, 5.5 Imp qt)

CAUTION: The SUBARU Genuine Coolant containing antifreeze and anti-rust agents is especially made for SUBARU engine, which has an aluminum crankcase. Always use SUBARU Genuine Coolant, since other coolant may cause corrosion.

NOTE: To prevent cooling system leaks, always add Genuine Subaru Cooling System Conditioner (P/N SOA635071) whenever the coolant is replaced.

- 2) Fill engine coolant into reservoir tank up to upper level.

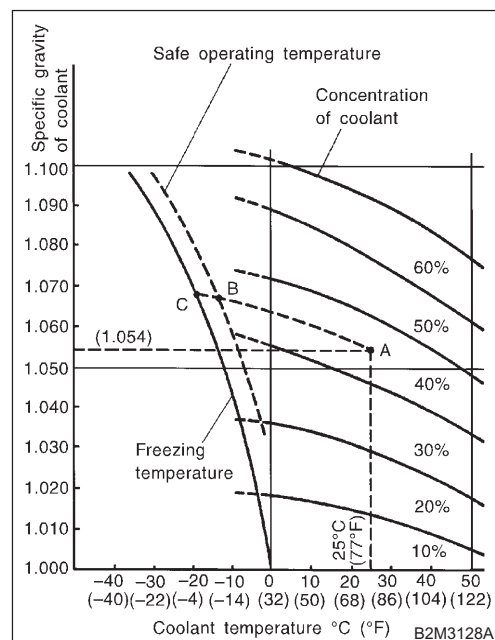

2. PROCEDURE TO ADJUST THE CONCENTRATION OF THE COOLANT

To adjust the concentration of the coolant according to temperature, find the proper fluid concentration in the above diagram and replace the necessary amount of coolant with an undiluted solution of SUBARU genuine coolant (concentration 50%).

The amount of coolant that should be replaced can be determined using the diagram.

[Example]

Assume that the coolant concentration must be increased from 25% to 40%. Find point A, where the 25% line of coolant concentration intersects with the 40% curve of the necessary coolant concentration, and read the scale on the vertical axis of the graph at height A. The quantity of coolant to be drained is 2.1 liters (2.2 US qt, 1.8 Imp qt). Drain 2.1 liters (2.2 US qt, 1.8 Imp qt) of coolant from the cooling system and add 2.1 liters (2.2 US qt, 1.8 Imp qt) of the undiluted solution of SUBARU coolant.

If a coolant concentration of 50% is needed, drain all the coolant and refill with the undiluted solution only.

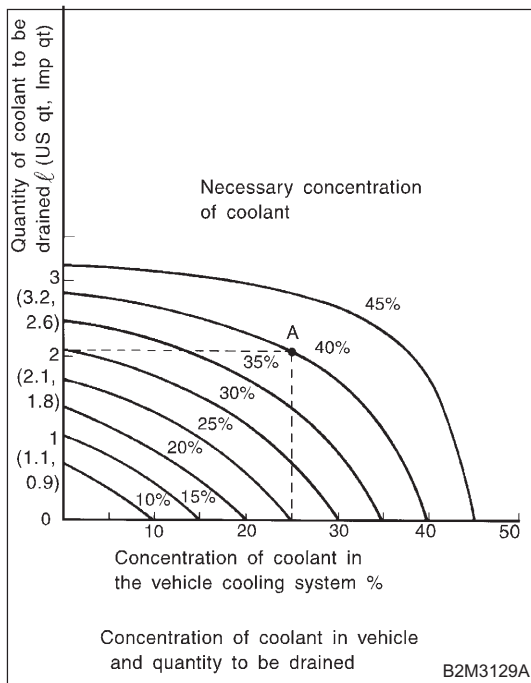

12. Coolant

A: REPLACEMENT

1. REPLACEMENT OF COOLANT

WARNING:

The radiator is of the pressurized type. Do not attempt to open the radiator cap immediately after the engine has been stopped.

- 1) Lift up the vehicle.
- 2) Remove under cover.
- 3) Fit vinyl tube to drain pipe.
- 4) Place a container under drain tube.
- 5) Loosen drain cock to drain engine coolant into container.

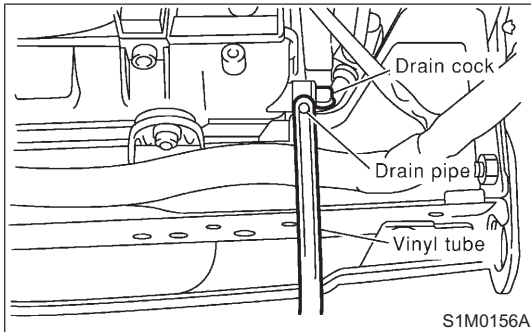

- 6) For quick draining, open radiator cap.

CAUTION: Be careful not to spill coolant on the floor.

- 7) Drain coolant from reservoir tank.
- 8) Tighten radiator drain screw securely after draining coolant.
- 9) Install reservoir tank to original position.
- 10) Slowly pour prepared coolant from radiator filler port to neck of filler, then pour into reservoir tank up to "FULL" level.

Coolant capacity (fill up to "FULL" level)
Approx. 6.0ℓ (6.3 US qt, 5.3 Imp qt)

NOTE: The SUBARU Genuine Coolant containing antifreeze and anti-rust agents is especially made for SUBARU engine, which has an aluminum crankcase. Always use SUBARU Genuine Coolant, since other coolant may cause corrosion.

NOTE: To prevent cooling system leaks, always add Genuine Subaru Cooling System Conditioner (P/N SOA635071) whenever the coolant is replaced.

- 11) Securely install radiator cap.
- 12) Run engine for more than five minutes at 2,000 to 3,000 rpm. (Run engine until radiator becomes hot in order to purge air trapped in cooling system.)
- 13) Stop engine and wait until coolant temperature lowers. Then open radiator cap to check coolant level and add coolant up to radiator filler neck. Next, add coolant into reservoir tank up to "FULL" level.
- 14) After adding coolant, securely install radiator and reservoir tank caps.

2. RELATIONSHIP OF SUBARU COOLANT CONCENTRATION AND FREEZING TEMPERATURE

The concentration and safe operating temperature of the SUBARU coolant is shown in the diagram. Measuring the temperature and specific gravity of the coolant will provide this information.

[Example]

If the coolant temperature is 25°C (77°F) and its specific gravity is 1.054, the concentration is 35% (point A), the safe operating temperature is -14°C (7°F) (point B), and the freezing temperature is -20°C (-4°F) (point C).

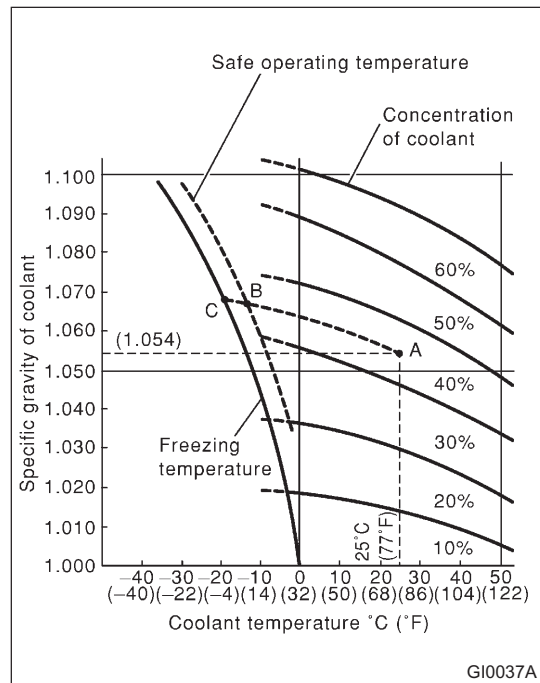

RECOMMENDED MATERIALS

RECOMMENDED MATERIALS

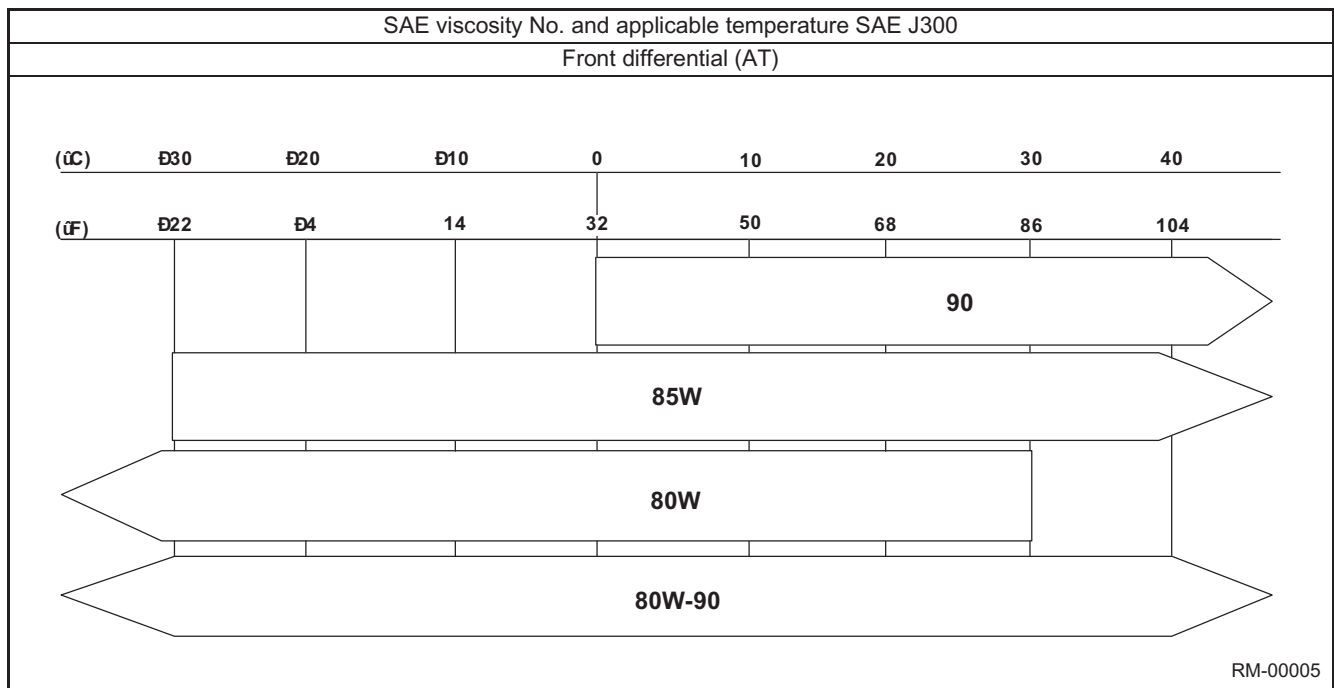

4. FLUID

Use the fluids specified in the table below. Do not mix two different kinds or makes of fluid.

Fluid	Recommended	Alternative	Remarks
Automatic transmission fluid	DEXRON III	—	—
Power steering fluid	DEXRON III	—	—
Brake fluid	FMVSS No. 116 DOT3	FMVSS No. 116 DOT4	—
Clutch fluid	FMVSS No. 116 DOT3	FMVSS No. 116 DOT4	—

5. COOLANT

Use genuine coolant to protect the engine.

Coolant	Recommended	Item number	Alternative
Coolant	SUBARU coolant	000016218	None
Water for dilution	Distilled water	—	Tap water (Soft water)
Coolant Conditioner	Subaru Coolant Conditioner	SOA635071	None

6. REFRIGERANT

Standard air conditioners on Subaru vehicles use HFC134a refrigerant. Do not mix it with other refrigerants. Also, do not use any air compressor oil except for ZXL200PG.

Air conditioner	Recommended	Item number	Alternative
Refrigerant	HFC134a	—	None
Compressor oil	ZXL200PG	—	None

7. GREASE

Use the grease and supplementary lubricants shown in the table below.

Grease	Application point	Recommended	Item number	Alternative
Supplementary lubricants	O ₂ sensor Bolts, etc.	SUBARU CRC	004301003	—

4. Engine Coolant

A: REPLACEMENT

1. DRAINING OF ENGINE COOLANT

- 1) Lift-up the vehicle.
- 2) Remove the under cover.
- 3) Remove the drain cock to drain engine coolant into container.

NOTE:

Remove the radiator cap so that engine coolant will drain faster.

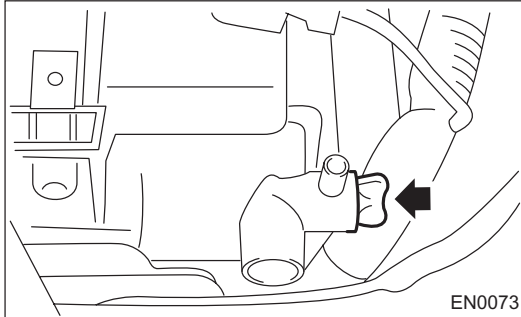

2. FILLING OF ENGINE COOLANT

- 1) Fill engine coolant into radiator up to the filler neck position.

Coolant capacity (fill up to "FULL" level):

Non-turbo AT model

Approx. 6.9 ℓ (7.29 US qt, 6.07 Imp qt)

Non-turbo MT model

Approx. 7 ℓ (7.4 US qt, 6.2 Imp qt)

Turbo AT model

Approx. 7.6 ℓ (8.03 US qt, 6.69 Imp qt)

Turbo MT model

Approx. 7.7 ℓ (8.14 US qt, 6.78 Imp qt)

CAUTION: The SUBARU Genuine Coolant containing antifreeze and anti-rust agents is especially made for SUBARU engine, which has an aluminum crankcase. Always use SUBARU Genuine Coolant, since other coolant may cause corrosion. To prevent cooling system leaks, always add Genuine Subaru Cooling System Conditioner (Part No. SOA635071) whenever the coolant is replaced.

- 2) Fill engine coolant into reservoir tank up to the upper level.

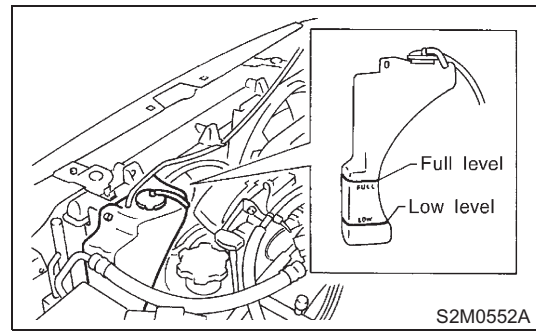

- 3) Warm-up engine completely for more than five minutes at 2,000 to 3,000 rpm.
- 4) If the engine coolant level drops in radiator, add the engine coolant to filler neck position.
- 5) If the engine coolant level drops from upper level of reservoir tank, add the engine coolant to the upper level.
- 6) Attach the radiator cap and reservoir tank cap properly.

12. Coolant

A: REPLACEMENT

1. REPLACEMENT OF COOLANT

WARNING:

The radiator is of the pressurized type. Do not attempt to open the radiator cap immediately after the engine has been stopped.

- 1) Lift up the vehicle.
- 2) Remove the under cover.
- 3) Place a container under drain pipe.
- 4) Loosen and remove the drain plug to drain engine coolant into the container.

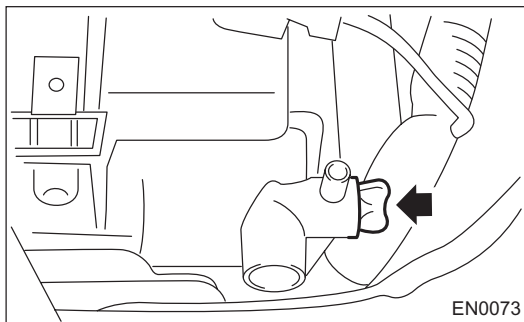

- 5) For quick draining, open the radiator cap.

CAUTION:

Be careful not to spill coolant on the floor.

- 6) Drain the coolant from reservoir tank.
- 7) Tighten the radiator drain screw securely after draining coolant.
- 8) Slowly pour the prepared coolant from radiator filler port to neck of filler, then pour into the reservoir tank up to the "FULL" level.

Coolant capacity (fill up to "FULL" level)

Non-turbo AT model:

Approx. 6.9 ℓ (7.3 US qt, 6.1 Imp qt)

Non-turbo MT model:

Approx. 7.0 ℓ (7.4 US qt, 6.2 Imp qt)

Turbo AT model:

Approx. 7.6 ℓ (8.0 US qt, 6.7 Imp qt)

Turbo MT model:

Approx. 7.7 ℓ (8.1 US qt, 6.8 Imp qt)

NOTE: The SUBARU Genuine Coolant containing antifreeze and anti-rust agents is especially made for SUBARU engine, which has an aluminum crankcase. Always use SUBARU Genuine Coolant, since other coolant may cause corrosion. To prevent cooling system leaks, always add Genuine Subaru Cooling System Conditioner (Part No. SOA635071) whenever the coolant is replaced.

- 9) Securely install the radiator cap.

- 10) Run engine for more than five minutes at 2,000 to 3,000 rpm. (Run engine until radiator becomes hot in order to purge air trapped in cooling system.)

- 11) Stop the engine and wait until coolant temperature lowers. Then open the radiator cap to check coolant level and add coolant up to radiator filler neck. Next, add coolant into reservoir tank up to "Full" level.

- 12) After adding coolant, securely the install radiator and reservoir tank caps.

RECOMMENDED MATERIALS

RECOMMENDED MATERIALS

SAE viscosity	SAE viscosity No. and applicable temperature SAE J300								
Manual Transmission Oil	(°C)	-30	-20	-10	0	10	20	30	40
	(°F)	-22	-4	14	32	50	68	86	104
Rear Differential	90								
	85W								
	80W								
	75W-90								
GI0004A									
Front Differential	(°C)	-30	-20	-10	0	10	20	30	40
	(°F)	-22	-4	14	32	50	68	86	104
90									
85W									
80W									
80W-90									
GI0005A									

4. FLUID

Use the fluids specified in the table below. Do not mix two different kinds or makes of fluid.

Fluid	Recommended	Alternative	Remarks
Automatic transmission fluid	DEXRON III	—	—
Power steering fluid	DEXRON III	—	—
Brake fluid	FMVSS No. 116 DOT3	FMVSS No. 116 DOT4	—
Clutch fluid	FMVSS No. 116 DOT3	FMVSS No. 116 DOT4	—

5. COOLANT

Use the genuine coolant to protect the engine. The table below shows the ratio of coolant to distilled water.

Coolant	Recommended	Item number	Alternative
Coolant	SUBARU coolant	000016218	None
Water for dilution	Distilled water	—	Tap water
Coolant Conditioner	Subaru Coolant Conditioner	SOA635071	None

6. REFRIGERANT

Standard air conditioners on Subaru vehicles use HFC134a refrigerant. Do not mix it with other refrigerants. Also, do not use any air compressor oil except for DH-PR.

Air conditioner	Recommended	Item number	Alternative
Refrigerant	HFC134a	—	None
Compressor oil	DH-PR	—	None

4. Engine Coolant S146060

A: REPLACEMENT S146060A20

1. DRAINING OF ENGINE COOLANT

S146060A2001

- 1) Lift-up the vehicle.
- 2) Remove under cover.

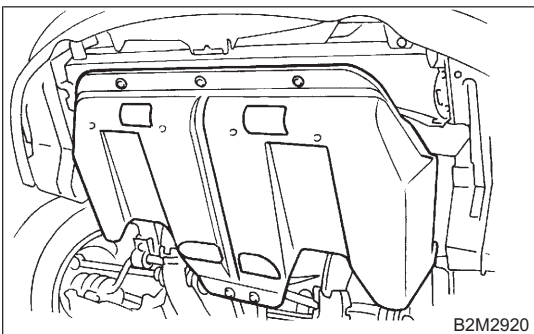

- 3) Remove drain cock to drain engine coolant into container.

NOTE:

Remove radiator cap so that engine coolant will drain faster.

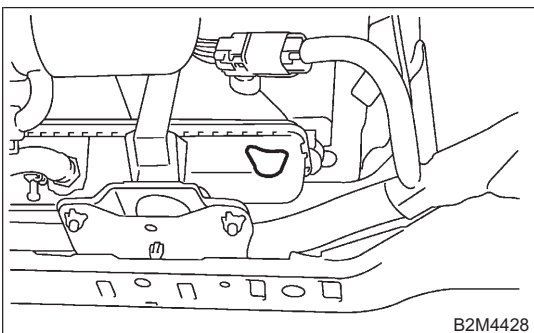

2. FILLING OF ENGINE COOLANT S146060A2002

- 1) Fill engine coolant into radiator up to filler neck position.

Engine oil amount for refill:

Approx. 7.9ℓ (8.4 US qt, 7.0 Imp qt)

CAUTION: The SUBARU Genuine Coolant containing antifreeze and anti-rust agents is especially made for SUBARU engine, which has an aluminum crankcase. Always use SUBARU Genuine Coolant, since other coolant may cause corrosion. To prevent cooling system leaks, always add Genuine Subaru Cooling System Conditioner (Part No. SOA635071) whenever the coolant is replaced.

- 2) Fill engine coolant into reservoir tank up to upper level.

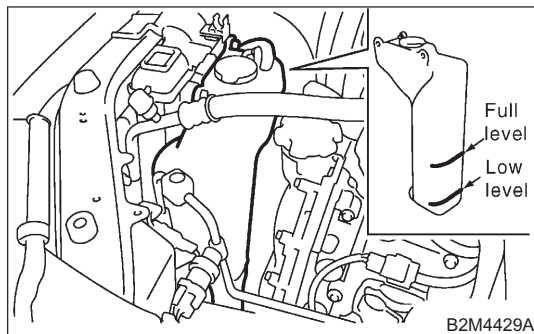

- 3) Attach radiator cap and reservoir tank cap properly.
- 4) Warm-up engine completely for more than five minutes at 2,000 to 3,000 rpm.
- 5) If engine coolant level drops in radiator, add engine coolant to filler neck position.
- 6) If engine coolant level drops from upper level of reservoir tank, add engine coolant to upper level.
- 7) Attach radiator cap and reservoir tank cap properly.

B: INSPECTION S146060A10

1. RELATIONSHIP OF SUBARU COOLANT CONCENTRATION AND FREEZING TEMPERATURE S146060A1001

The concentration and safe operating temperature of the SUBARU coolant is shown in the diagram. Measuring the temperature and specific gravity of the coolant will provide this information.

4. Engine Coolant S176060

A: REPLACEMENT S176060A20

1. DRAINING OF ENGINE COOLANT

S176060A2001

- 1) Lift-up the vehicle.
- 2) Remove under cover.

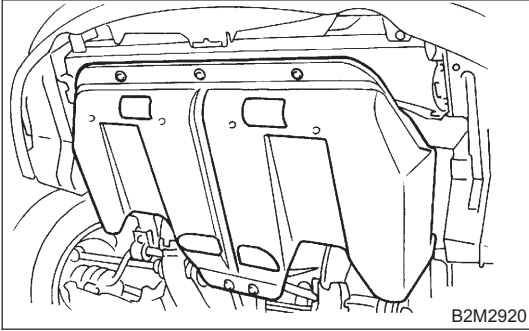

- 3) Remove drain cock to drain engine coolant into container.

NOTE:

Remove radiator cap so that engine coolant will drain faster.

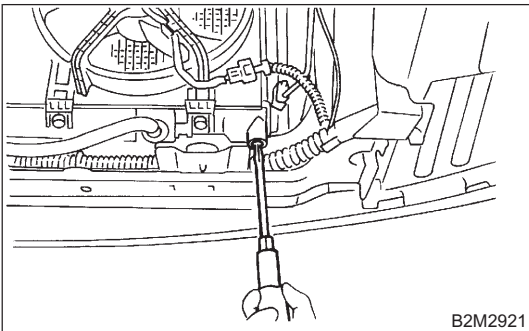

2. FILLING OF ENGINE COOLANT S176060A2002

- 1) Fill engine coolant into radiator up to filler neck position.

Engine oil amount for refill:

MT model;

Approx. 6.8ℓ (7.2 US qt, 6.0 Imp qt)

AT model;

Approx. 6.7ℓ (7.1 US qt, 5.9 Imp qt)

CAUTION: The SUBARU Genuine Coolant containing antifreeze and anti-rust agents is especially made for SUBARU engine, which has an aluminum crankcase. Always use SUBARU Genuine Coolant, since other coolant may cause corrosion. To prevent cooling system leaks, always add Genuine Subaru Cooling System Conditioner (Part No. SOA635071) whenever the coolant is replaced.

- 2) Fill engine coolant into reservoir tank up to upper level.

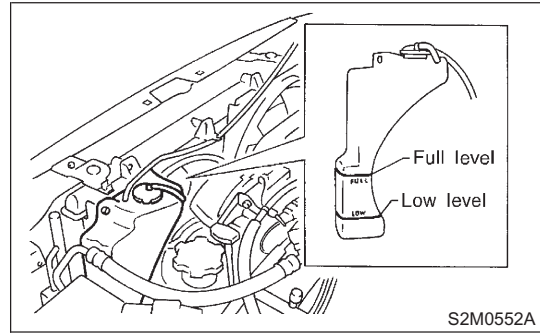

- 3) Attach radiator cap and reservoir tank cap properly.
- 4) Warm-up engine completely for more than five minutes at 2,000 to 3,000 rpm.
- 5) If engine coolant level drops in radiator, add engine coolant to filler neck position.
- 6) If engine coolant level drops from upper level of reservoir tank, add engine coolant to upper level.
- 7) Attach radiator cap and reservoir tank cap properly.

B: INSPECTION S176060A10

1. RELATIONSHIP OF SUBARU COOLANT CONCENTRATION AND FREEZING TEMPERATURE S176060A1001

The concentration and safe operating temperature of the SUBARU coolant is shown in the diagram. Measuring the temperature and specific gravity of the coolant will provide this information.

12. Coolant SA07689

A: REPLACEMENT SA07689A20

1. REPLACEMENT OF COOLANT SA07689A2001

WARNING:

The radiator is of the pressurized type. Do not attempt to open the radiator cap immediately after the engine has been stopped.

- 1) Lift up the vehicle.
- 2) Remove under cover.
- 3) Place a container under drain pipe.
- 4) Loosen and remove drain screw to drain engine coolant into container.

2.5 L model

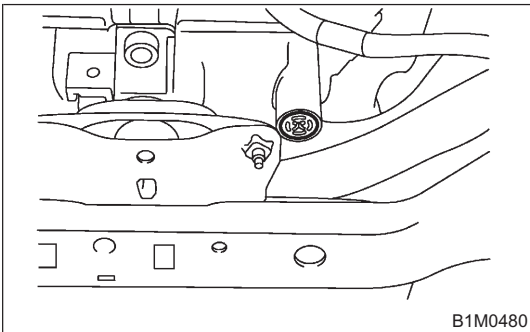

3.0 L model

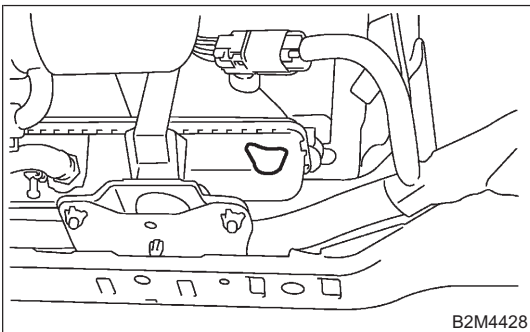

- 5) For quick draining, open radiator cap.

CAUTION:

Be careful not to spill coolant on the floor.

- 6) Drain coolant from reservoir tank.
- 7) Tighten radiator drain screw securely after draining coolant.

- 8) Slowly pour prepared coolant from radiator filler port to neck of filler, then pour into reservoir tank up to "FULL" level.

Coolant amount for preparation

2.5 L model

MT model:

Approx. 6.8ℓ (7.2 US qt, 6.0 Imp qt)

AT model:

Approx. 6.7ℓ (7.1 US qt, 5.9 Imp qt)

3.0 L model

Approx. 7.9ℓ (8.4 US qt, 7.0 Imp qt)

NOTE: The SUBARU Genuine Coolant containing antifreeze and anti-rust agents is especially made for SUBARU engine, which has an aluminum crankcase. Always use SUBARU Genuine Coolant, since other coolant may cause corrosion. To prevent cooling system leaks, always add Genuine Subaru Cooling System Conditioner (Part No. SOA635071) whenever the coolant is replaced.

- 9) Securely install radiator cap.
- 10) Run engine for more than five minutes at 2,000 to 3,000 rpm. (Run engine until radiator becomes hot in order to purge air trapped in cooling system.)
- 11) Stop engine and wait until coolant temperature lowers. Then open radiator cap to check coolant level and add coolant up to radiator filler neck. Next, add coolant into reservoir tank up to "FULL" level.
- 12) After adding coolant, securely install radiator and reservoir tank caps.

RECOMMENDED MATERIALS

Recommended Materials

4. FLUID SA05678G2204

Use the fluids specified in the table below. Do not mix two different kinds or makes of fluid.

Fluid	Recommended	Alternative	Remarks
Automatic transmission fluid	DEXRON III	—	—
Power steering fluid	DEXRON III	—	—
Brake fluid	FMVSS No. 116 DOT3	FMVSS No. 116 DOT4	—
Clutch fluid	FMVSS No. 116 DOT3	FMVSS No. 116 DOT4	—

5. COOLANT SA05678G2205

Use genuine coolant to protect the engine.

Coolant	Recommended	Item number	Alternative
Coolant	SUBARU coolant	000016218	None
Water for dilution	Distilled water	—	Tap water
Coolant Conditioner	Subaru Coolant Conditioner	SOA635071	None

6. REFRIGERANT SA05678G2206

Standard air conditioners on Subaru vehicles use HFC134a refrigerant. Do not mix it with other refrigerants. Also, do not use any air compressor oil except for ZXL200PG.

Air conditioner	Recommended	Item number	Alternative
Refrigerant	HFC134a	—	None
Compressor oil	ZXL200PG	—	None

7. GREASE SA05678G2207

Use the grease and supplementary lubricants shown in the table below.

Grease	Application point	Recommended	Item number	Alternative
Supplementary lubricants	- O2 sensor - Bolts, etc.	SUBARU CRC	004301003	—
Grease	MT main shaft	FX clutch grease	000040901	—
	Clutch master cylinder push rod	Slicolube G-40M	004404003	—
	- Steering shaft bush (Toe board) - Gear shift bush	SUNLIGHT2	003602010	—
	Steering gear box	Valiant grease M-2	003608001	—
	Disc brake	Niglube RX-2	725191040	—
	Drum brake	Molykote No. 7439	725191460	—
	- Brake pad - Brake shoe	Molykote AS-880N	K0777YA010	—
	Front axle SFJ	SSG-6003	28093TA000	—
	Front axle BJ	NTG2218	28093AA000	—
	Rear axle BJ	Molylex No. 2	723223010	—
	Rear axle DOJ	VU-3A702	23223GA050	—
	- Control cable - Throttle linkage Water pump - Door latch - Door striker	Slicolube G-30M	004404002	—

RM-5

replacement page for MSA5T0201A

ENGINE COOLANT

COOLING

3. Engine Coolant

A: REPLACEMENT

1. DRAINING OF ENGINE COOLANT

- 1) Lift-up the vehicle.
- 2) Remove the under cover.
- 3) Loosen the drain cock to drain engine coolant into container.

NOTE: Remove the radiator cap so that engine coolant will drain faster.

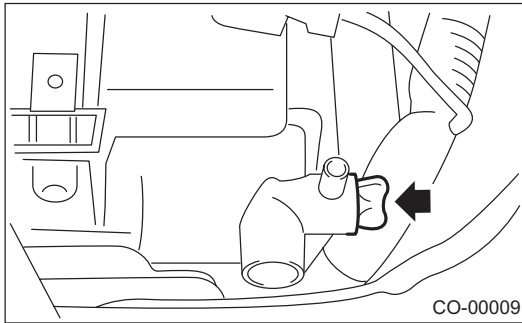

2. FILLING OF ENGINE COOLANT

- 1) Fill engine coolant into the radiator up to filler neck position.

Coolant capacity (fill up to "FULL" level):

AT model

Approx. 6.8ℓ (7.19 US qt, 5.98 Imp qt)

MT model

Approx. 6.9ℓ (7.40 US qt, 6.16 Imp qt)

NOTE: The Subaru Genuine Coolant containing antifreeze and anti-rust agents is especially made for Subaru engine, which has an aluminum crankcase. Always use Subaru Genuine Coolant, since other coolant may cause corrosion.

NOTE: To prevent cooling system leaks, always add Genuine Subaru Cooling System Conditioner (P/N SOA635071) whenever the coolant is replaced.

- 2) Fill engine coolant into the reservoir tank up to "FULL" level.

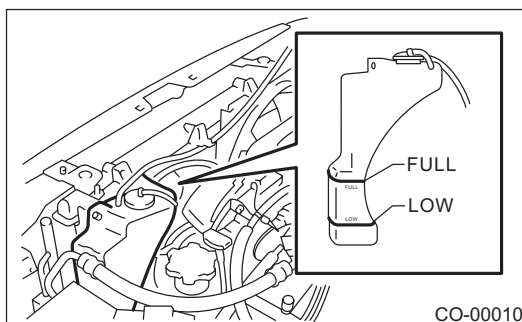

- 3) Warm-up the engine completely for more than 5 minutes at 2,000 to 3,000 rpm.

- 4) If the engine coolant level drops in radiator, add engine coolant to filler neck position.

- 5) If the engine coolant level drops from FULL level of reservoir tank, add engine coolant to FULL level.

- 6) Attach the radiator cap and reservoir tank cap properly.

B: INSPECTION

1. RELATIONSHIP OF SUBARU COOLANT CONCENTRATION AND FREEZING TEMPERATURE

The concentration and safe operating temperature of the Subaru coolant is shown in the diagram. Measuring the temperature and specific gravity of the coolant will provide this information.

[Example]

If the coolant temperature is 25°C (77°F) and its specific gravity is 1.054, the concentration is 35% (point A), the safe operating temperature is -14°C (7°F) (point B), and the freezing temperature is -20°C (-4°F) (point C).

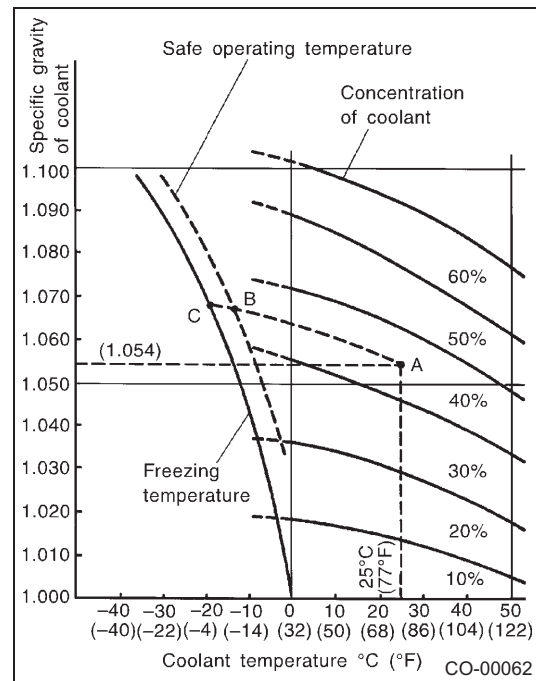

CO(SOHC)-14

replacement page for MSA5T0322A

12. Coolant

A: REPLACEMENT

1. REPLACEMENT OF COOLANT

WARNING:

The radiator is of the pressurized type. Do not attempt to open the radiator cap immediately after the engine has been stopped.

- 1) Lift-up the vehicle.
- 2) Remove the under cover.
- 3) Place a container under drain pipe.
- 4) Loosen and remove the drain cock to drain engine coolant into container.

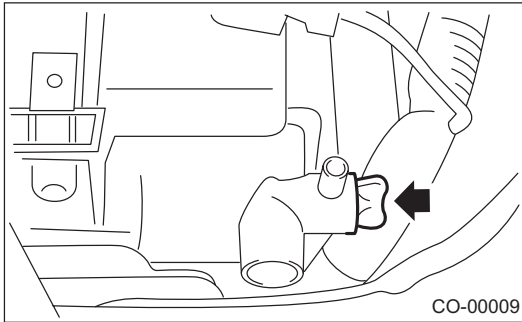

- 5) For quick draining, open the radiator cap.
- NOTE: Be careful not to spill coolant on the floor.
- 6) Drain the coolant from reservoir tank.
 - 7) Tighten the radiator drain cock securely after draining coolant.
 - 8) Slowly pour the prepared coolant from radiator filler port to neck of filler, then pour into reservoir tank up to "FULL" level.

Coolant capacity (fill up to "FULL" level)

AT VEHICLES:

Approx. 6.8 ℓ (7.2 US qt, 6.0 Imp qt)

MT VEHICLES:

Approx. 6.9 ℓ (7.3 US qt, 6.1 Imp qt)

NOTE: The SUBARU Genuine Coolant containing antifreeze and anti-rust agents is especially made for SUBARU engine, which has an aluminum crankcase. Always use SUBARU Genuine Coolant, since other coolant may cause corrosion.

NOTE: To prevent cooling system leaks, always add Genuine Subaru Cooling System Conditioner (P/N SOA635071) whenever the coolant is replaced.

- 9) Securely install the radiator cap.

10) Run the engine for more than 5 minutes at 2,000 to 3,000 rpm. (Run the engine until radiator becomes hot in order to purge the air trapped in cooling system.)

11) Stop the engine and wait until coolant temperature lowers. Then open the radiator cap to check coolant level and add coolant up to radiator filler neck. Next, add coolant into reservoir tank up to "FULL" level.

12) After adding coolant, securely install the radiator and reservoir tank caps.

2. RELATIONSHIP OF SUBARU COOLANT CONCENTRATION AND FREEZING TEMPERATURE

The concentration and safe operating temperature of the SUBARU coolant is shown in the diagram. Measuring the temperature and specific gravity of the coolant will provide this information.

[Example]

If the coolant temperature is 25°C (77°F) and its specific gravity is 1.054, the concentration is 35% (point A), the safe operating temperature is -14°C (7°F) (point B), and the freezing temperature is -20°C (-4°F) (point C).

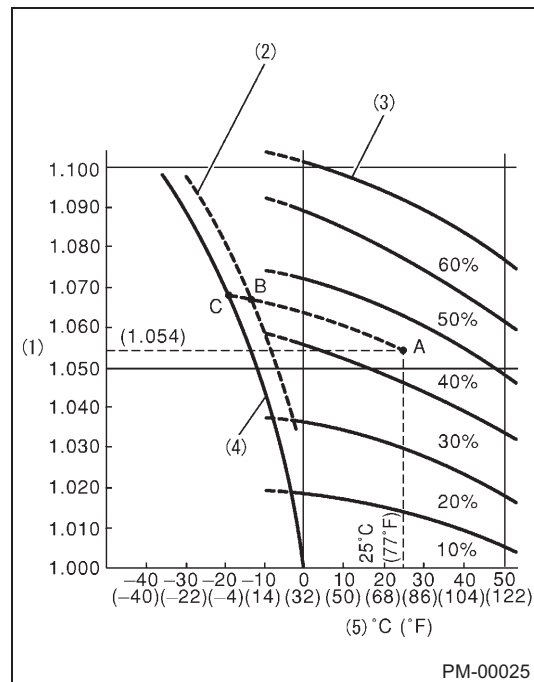

- (1) Coolant gravity
- (2) Safe operating temperature
- (3) Concentration of coolant
- (4) Freezing temperature
- (5) Coolant temperature

RECOMMENDED MATERIALS

RECOMMENDED MATERIALS

SAE viscosity No. and applicable temperature SAE J300								
Front differential (AT)								
(iC)	Ø30	Ø20	Ø10	0	10	20	30	40
(iF)	Ø22	Ø4	14	32	50	68	86	104
								90
								85W
								80W
								80W-90

RM-00005

4. FLUID

Use the fluids specified in the table below. Do not mix two different kinds or makes of fluid.

Fluid	Recommended	Alternative	Remarks
Automatic transmission fluid	DEXRON III	—	—
Power steering fluid	DEXRON III	—	—
Brake fluid	FMVSS No. 116 DOT3	FMVSS No. 116 DOT4	—
Clutch fluid	FMVSS No. 116 DOT3	FMVSS No. 116 DOT4	—

5. COOLANT

Use genuine coolant to protect the engine.

Coolant	Recommended	Item number	Alternative
Coolant	SUBARU coolant	000016218	None
Water for dilution	Distilled water	—	Tap water (Soft water)
Coolant Conditioner	Subaru Coolant Conditioner	SOA635071	None

6. REFRIGERANT

Standard air conditioners on Subaru vehicles use HFC134a refrigerant. Do not mix it with other refrigerants. Also, do not use any air compressor oil except for ZXL200PG.

Air conditioner	Recommended	Item number	Alternative
Refrigerant	HFC134a	—	None
Compressor oil	ZXL200PG	—	None

7. GREASE

Use the grease and supplementary lubricants shown in the table below.

Grease	Application point	Recommended	Item number	Alternative
Supplementary lubricants	O ₂ sensor Bolts, etc.	SUBARU CRC	004301003	—

RM-4

replacement page for MSA5T0320A

4. Engine Coolant

A: REPLACEMENT

1. DRAINING OF ENGINE COOLANT

- 1) Lift-up the vehicle.
- 2) Remove the under cover.
- 3) Remove the drain cock to drain engine coolant into container.

NOTE:

Remove the radiator cap so that engine coolant will drain faster.

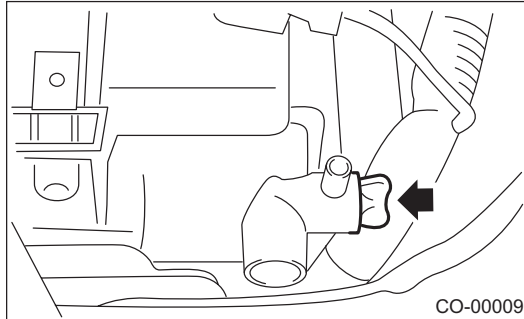

2. FILLING OF ENGINE COOLANT

- 1) Fill engine coolant into radiator up to the filler neck position.

Coolant capacity (fill up to "FULL" level):

Non-turbo AT model

Approx. 6.9ℓ (7.29 US qt, 6.07 Imp qt)

Non-turbo MT model

Approx. 7ℓ (7.4 US qt, 6.2 Imp qt)

Turbo AT model

Approx. 7.6ℓ (8.03 US qt, 6.69 Imp qt)

Turbo MT model

Approx. 7.7ℓ (8.14 US qt, 6.78 Imp qt)

CAUTION: The SUBARU Genuine Coolant containing antifreeze and anti-rust agents is especially made for SUBARU engine, which has an aluminum crankcase. Always use SUBARU Genuine Coolant, since other coolant may cause corrosion.

NOTE: To prevent cooling system leaks, always add Genuine Subaru Cooling System Conditioner (P/N SOA635071) whenever the coolant is replaced.

- 2) Fill engine coolant into reservoir tank up to the upper level.

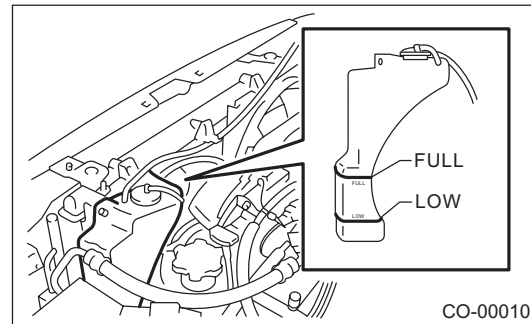

- 3) Warm-up engine completely for more than five minutes at 2,000 to 3,000 rpm.
- 4) If the engine coolant level drops in radiator, add the engine coolant to filler neck position.
- 5) If the engine coolant level drops from upper level of reservoir tank, add the engine coolant to the upper level.
- 6) Attach the radiator cap and reservoir tank cap properly.

B: INSPECTION

1. RELATIONSHIP OF SUBARU COOLANT CONCENTRATION AND FREEZING TEMPERATURE

The concentration and safe operating temperature of the SUBARU coolant is shown in the diagram. Measuring the temperature and specific gravity of the coolant will provide this information.

12. Coolant

A: REPLACEMENT

1. REPLACEMENT OF COOLANT

WARNING: The radiator is of the pressurized type. Do not attempt to open the radiator cap immediately after the engine has been stopped.

- 1) Lift up the vehicle.
- 2) Remove the under cover.
- 3) Place a container under drain pipe.
- 4) Loosen and remove the drain plug to drain engine coolant into the container.

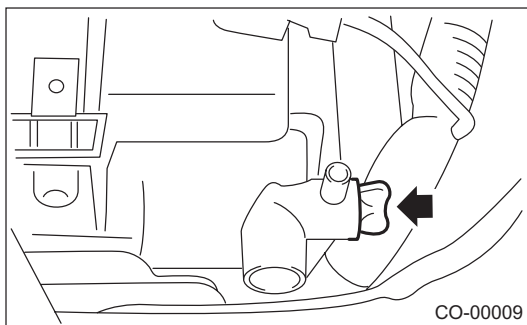

- 5) For quick draining, open the radiator cap.

CAUTION: Be careful not to spill coolant on the floor.

- 6) Drain the coolant from reservoir tank.
- 7) Tighten the radiator drain screw securely after draining coolant.
- 8) Slowly pour the prepared coolant from radiator filler port to neck of filler, then pour into the reservoir tank up to "FULL" level.

Coolant amount for preparation

Non-turbo AT model:

Approx. 6.9ℓ (7.3 US qt, 6.1 Imp qt)

Non-turbo MT model:

Approx. 7.0ℓ (7.4 US qt, 6.2 Imp qt)

Turbo AT model:

Approx. 7.6ℓ (8.0 US qt, 6.7 Imp qt)

Turbo MT model:

Approx. 7.7ℓ (8.1 US qt, 6.8 Imp qt)

NOTE: The SUBARU Genuine Coolant containing antifreeze and anti-rust agents is especially made for SUBARU engine, which has an aluminum crankcase. Always use SUBARU Genuine Coolant, since other coolant may cause corrosion.

NOTE: To prevent cooling system leaks, always add Genuine Subaru Cooling System Conditioner (P/N SOA635071) whenever the coolant is replaced.

- 9) Securely install the radiator cap.
- 10) Run engine for more than five minutes at 2,000 to 3,000 rpm. (Run engine until radiator becomes hot in order to purge air trapped in cooling system.)

11) Stop the engine and wait until coolant temperature lowers. Then open the radiator cap to check coolant level and add coolant up to radiator filler neck. Next, add coolant into reservoir tank up to "FULL" level.

- 12) After adding coolant, securely the install radiator and reservoir tank caps.

RECOMMENDED MATERIALS

RECOMMENDED MATERIALS

5. COOLANT

Use the genuine coolant to protect the engine.

Coolant	Recommended	Item number	Alternative
Coolant	SUBARU coolant	000016218	None
Water for dilution	Distilled water	—	Tap water
Coolant Conditioner	Subaru Coolant Conditioner	SOA635071	None

6. REFRIGERANT

Standard air conditioners on Subaru vehicles use HFC134a refrigerant. Do not mix it with other refrigerants. Also, do not use any air compressor oil except for DH-PR.

Air conditioner	Recommended	Item number	Alternative
Refrigerant	HFC134a	—	None
Compressor oil	DH-PR	—	None

7. GREASE

Use the grease and supplementary lubricants shown in the table below.

Grease	Application point	Recommended	Item number	Alternative
Supplementary lubricants	O ₂ sensor Bolts, etc.	SUBARU CRC	004301003	—
Grease	MT main shaft	FX clutch grease	000040901	—
	Clutch master cylinder push rod	Slicolube G-40M	004404003	—
	Gear shift lever Select lever Clutch operating cylinder Accelerator pedal Clutch pedal Brake pedal Clutch bearing Clutch release lever Steering shaft bearing	SUNLIGHT2	003602010	—
	Steering gear box	Valiant grease M-2	003608001	—
	Disc brake	Niglube RX-2	K0779GA102	—
	Drum brake Brake shoe	Molykote No. 7439	003602001	—
	Brake pad	Molykote AS-880N	K0777YA010	—
	Front axle SFJ	SSG-6003	28093TA000	—
	Front axle EBJ	NTG 2218	28093AA000	—
	Rear axle EBJ (Turbo model)	NTG 2218	28093AA000	—
	Rear axle BJ (Non-turbo model)	Molylex No. 2	723223010	—
	Rear axle DOJ	VU-3A702	23223GA050	—
	Throttle linkage Water pump Door latch Door striker	Slicolube G-30M	004404002	—

RM-5

replacement page for MSA5T0310A

4. Engine Coolant

A: REPLACEMENT

1. DRAINING OF ENGINE COOLANT

- 1) Lift-up the vehicle.
- 2) Remove under cover.

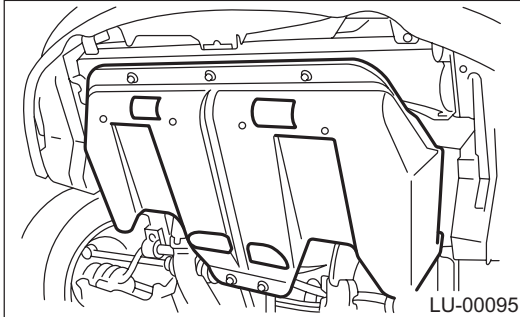

- 3) Remove drain cock to drain engine coolant into container.

NOTE:

Remove radiator cap so that engine coolant will drain faster.

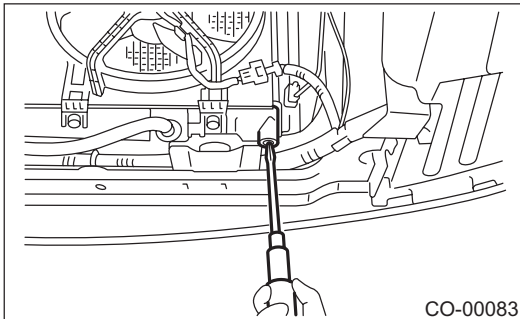

2. FILLING OF ENGINE COOLANT

- 1) Fill engine coolant into radiator up to filler neck position.

Engine coolant amount for refill:

MT model;

Approx. 6.8ℓ (7.2 US qt, 6.0 Imp qt)

AT model;

Approx. 6.7ℓ (7.1 US qt, 5.9 Imp qt)

CAUTION: The SUBARU Genuine Coolant containing antifreeze and anti-rust agents is especially made for SUBARU engine, which has an aluminum crankcase. Always use SUBARU Genuine Coolant, since other coolant may cause corrosion.

NOTE: To prevent cooling system leaks, always add Genuine Subaru Cooling System Conditioner (P/N SOA635071) whenever the coolant is replaced.

- 2) Fill engine coolant into reservoir tank up to upper level.

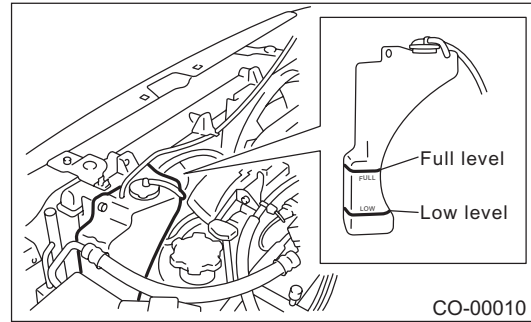

- 3) Attach radiator cap and reservoir tank cap properly.
- 4) Warm-up engine completely for more than five minutes at 2,000 to 3,000 rpm.
- 5) If engine coolant level drops in radiator, add engine coolant to filler neck position.
- 6) If engine coolant level drops from upper level of reservoir tank, add engine coolant to upper level.
- 7) Attach radiator cap and reservoir tank cap properly.

4. Engine Coolant

A: REPLACEMENT

1. DRAINING OF ENGINE COOLANT

- 1) Lift-up the vehicle.
- 2) Remove under cover.

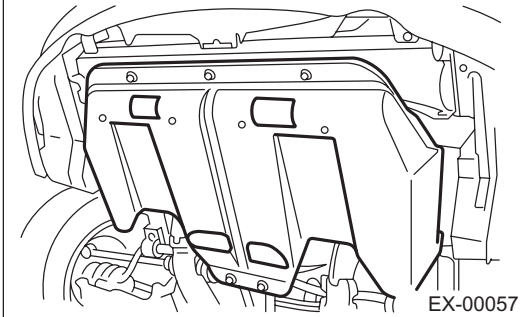

- 3) Remove drain cock to drain engine coolant into container.

NOTE:

Remove radiator cap so that engine coolant will drain faster.

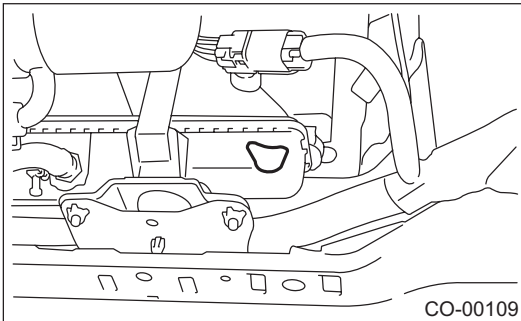

2. FILLING OF ENGINE COOLANT

- 1) Fill engine coolant into radiator up to filler neck position.

Coolant amount for refill:

Approx. 7.9 ℓ (8.4 US qt, 7.0 Imp qt)

CAUTION: The SUBARU Genuine Coolant containing antifreeze and anti-rust agents is especially made for SUBARU engine, which has an aluminum crankcase. Always use SUBARU Genuine Coolant, since other coolant may cause corrosion.

NOTE: To prevent cooling system leaks, always add Genuine Subaru Cooling System Conditioner (P/N SOA635071) whenever the coolant is replaced.

- 2) Fill engine coolant into reservoir tank up to upper level.

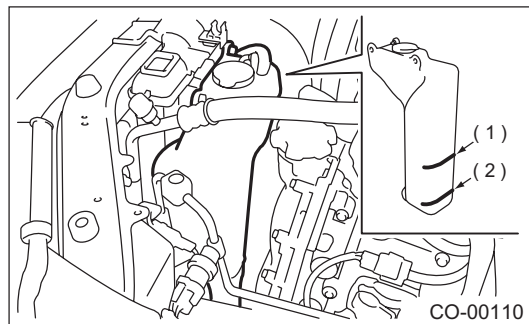

- (1) Full level
- (2) Low level

- 3) Attach radiator cap and reservoir tank cap properly.
- 4) Warm-up engine completely for more than five minutes at 2,000 to 3,000 rpm.
- 5) If engine coolant level drops in radiator, add engine coolant to filler neck position.
- 6) If engine coolant level drops from upper level of reservoir tank, add engine coolant to upper level.
- 7) Attach radiator cap and reservoir tank cap properly.

12. Coolant

A: REPLACEMENT

1. REPLACEMENT OF COOLANT

WARNING:

The radiator is of the pressurized type. Do not attempt to open the radiator cap immediately after the engine has been stopped.

- 1) Lift up the vehicle.
- 2) Remove under cover.
- 3) Place a container under drain pipe.
- 4) Loosen and remove drain screw to drain engine coolant into container.

2.5 L model

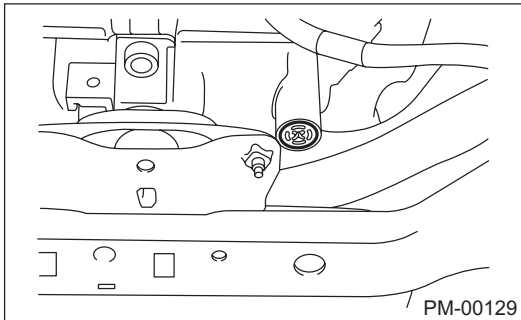

3.0 L model

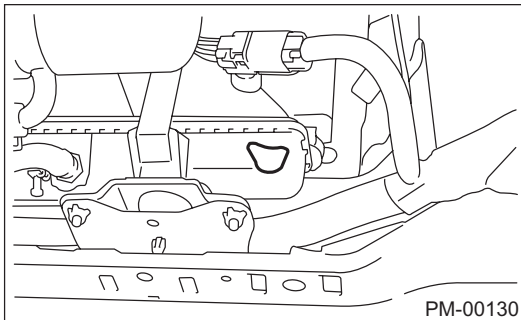

- 5) For quick draining, open radiator cap.

CAUTION:

Be careful not to spill coolant on the floor.

- 6) Drain coolant from reservoir tank.
- 7) Tighten radiator drain screw securely after draining coolant.

- 8) Slowly pour prepared coolant from radiator filler port to neck of filler, then pour into reservoir tank up to "FULL" level.

Coolant amount for preparation

2.5 L model

MT model:

Approx. 6.8ℓ (7.2 US qt, 6.0 Imp qt)

AT model:

Approx. 6.7ℓ (7.1 US qt, 5.9 Imp qt)

3.0 L model

Approx. 7.9ℓ (8.4 US qt, 7.0 Imp qt)

NOTE: The SUBARU Genuine Coolant containing antifreeze and anti-rust agents is especially made for SUBARU engine, which has an aluminum crankcase. Always use SUBARU Genuine Coolant, since other coolant may cause corrosion.

NOTE: To prevent cooling system leaks, always add Genuine Subaru Cooling System Conditioner (P/N SOA635071) whenever the coolant is replaced.

- 9) Securely install radiator cap.
- 10) Run engine for more than five minutes at 2,000 to 3,000 rpm. (Run engine until radiator becomes hot in order to purge air trapped in cooling system.)
- 11) Stop engine and wait until coolant temperature lowers. Then open radiator cap to check coolant level and add coolant up to radiator filler neck. Next, add coolant into reservoir tank up to "FULL" level.
- 12) After adding coolant, securely install radiator and reservoir tank caps.

RECOMMENDED MATERIALS

RECOMMENDED MATERIALS

SAE viscosity No. and applicable temperature SAE J300								
AT front differential gear oil								
(°C)	Ð30	Ð20	Ð10	0	10	20	30	40
(°F)	Ð22	Ð4	14	32	50	68	86	104
								90
								85W
								80W
								80W-90

RM-00005

4. FLUID

Use the fluids specified in the table below. Do not mix two different kinds or makes of fluid.

Fluid	Recommended	Alternative	Remarks
Automatic transmission fluid	DEXRON III	—	—
Power steering fluid	DEXRON III	—	—
Brake fluid	FMVSS No. 116 DOT3	FMVSS No. 116 DOT4	—
Clutch fluid	FMVSS No. 116 DOT3	FMVSS No. 116 DOT4	—

5. COOLANT

Use genuine coolant to protect the engine.

Coolant	Recommended	Item number	Alternative
Coolant	SUBARU coolant	000016218	None
Water for dilution	Distilled water	—	Tap water
Coolant Conditioner	SUBARU Coolant Conditioner	SOA635071	None

6. REFRIGERANT

Standard air conditioners on Subaru vehicles use HFC134a refrigerant. Do not mix it with other refrigerants. Also, do not use any air compressor oil except for ZXL200PG.

Air conditioner	Recommended	Item number	Alternative
Refrigerant	HFC134a	—	None
Compressor oil	ZXL200PG	—	None

3. Engine Coolant

A: REPLACEMENT

1. DRAINING OF ENGINE COOLANT

- 1) Lift-up the vehicle.
- 2) Remove the under cover.
- 3) Loosen the drain cock to drain engine coolant into container.

NOTE:

Remove the radiator cap so that engine coolant will drain faster.

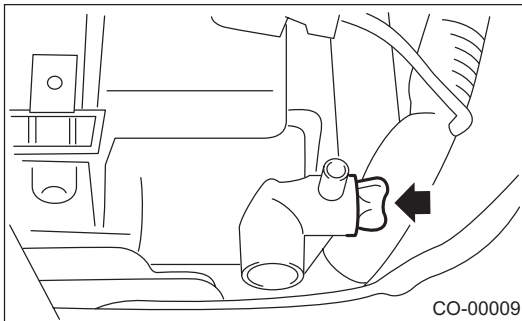

2. FILLING OF ENGINE COOLANT

- 1) Fill engine coolant into the radiator up to filler neck position.

Coolant capacity (fill up to "FULL" level):

Non-turbo (AT) model

Approx. 6.8ℓ (7.19 US qt, 5.98 Imp qt)

Non-turbo (MT) model

Approx. 6.9ℓ (7.29 US qt, 6.07 Imp qt)

Turbo (AT) model

Approx. 7.3ℓ (7.72 US qt, 6.42 Imp qt)

Turbo (MT) model

Approx. 7.4ℓ (7.82 US qt, 6.51 Imp qt)

NOTE: The Subaru Genuine Coolant containing antifreeze and anti-rust agents is especially made for Subaru engine, which has an aluminum crankcase. Always use Subaru Genuine Coolant, since other coolant may cause corrosion.

NOTE: To prevent cooling system leaks, always add Genuine Subaru Cooling System Conditioner (P/N SOA635071) whenever the coolant is replaced.

- 2) Fill engine coolant into the reservoir tank up to FULL level.

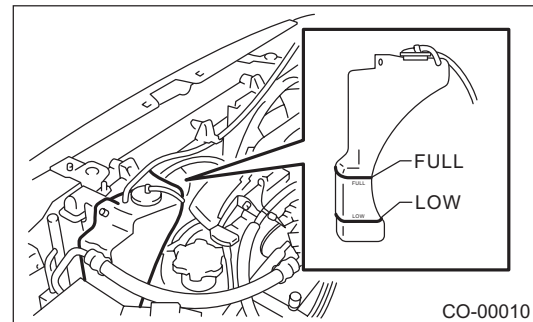

- 3) Warm-up the engine completely for more than 5 minutes at 2,000 to 3,000 rpm.
- 4) If the engine coolant level drops in radiator, add engine coolant to filler neck position.
- 5) If the engine coolant level drops from FULL level of reservoir tank, add engine coolant to FULL level.
- 6) Attach the radiator cap and reservoir tank cap properly.

12. Coolant

A: REPLACEMENT

1. REPLACEMENT OF COOLANT

WARNING:

The radiator is of the pressurized type. Do not attempt to open the radiator cap immediately after the engine has been stopped.

- 1) Lift-up the vehicle.
- 2) Remove the under cover.
- 3) Place a container under drain pipe.
- 4) Loosen and remove the drain cock to drain engine coolant into container.

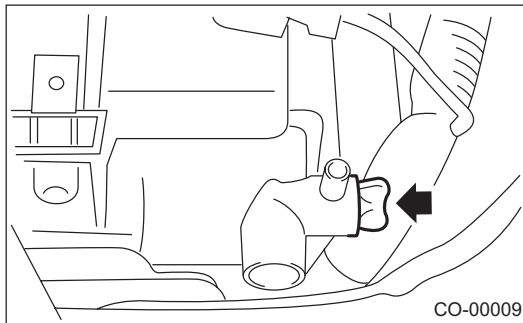

- 5) For quick draining, open the radiator cap.

CAUTION:

Be careful not to spill coolant on the floor.

- 6) Drain the coolant from reservoir tank.
- 7) Tighten the radiator drain cock securely after draining coolant.
- 8) Slowly pour the coolant from radiator filler port to neck of filler, then pour into reservoir tank up to "FULL" level.

Coolant capacity (fill up to "FULL" level)

Turbo AT model:

Approx. 7.3 ℓ (7.7 US qt, 6.4 Imp qt)

Turbo MT model:

Approx. 7.4 ℓ (7.8 US qt, 6.5 Imp qt)

Non-turbo AT model:

Approx. 6.8 ℓ (7.2 US qt, 6.0 Imp qt)

Non-turbo MT model:

Approx. 6.9 ℓ (7.3 US qt, 6.1 Imp qt)

NOTE: The SUBARU Genuine Coolant containing antifreeze and anti-rust agents is especially made for SUBARU engine, which has an aluminum crankcase. Always use SUBARU Genuine Coolant, since other coolant may cause corrosion.

NOTE: To prevent system leaks, always add Genuine Subaru Cooling System Conditioner (P/N SOA635071) whenever the coolant is replaced.

- 9) Securely install the radiator cap.
- 10) Run the engine for more than 5 minutes at 2,000 to 3,000 rpm. (Run the engine until radiator becomes hot in order to purge the air trapped in cooling system.)
- 11) Stop the engine and wait until coolant temperature lowers. Then open the radiator cap to check coolant level and add coolant up to radiator filler neck. Next, add coolant into reservoir tank up to "FULL" level.
- 12) After adding coolant, securely install the radiator and reservoir tank caps.

2. RELATIONSHIP OF SUBARU COOLANT CONCENTRATION AND FREEZING TEMPERATURE

The concentration and safe operating temperature of the SUBARU Genuine Coolant is shown in the diagram. Measuring the temperature and specific gravity of the coolant will provide this information.

[Example]

If the coolant temperature is 25°C (77°F) and its specific gravity is 1.054, the concentration is 35% (point A), the safe operating temperature is -14°C (7°F) (point B), and the freezing temperature is -20°C (-4°F) (point C).

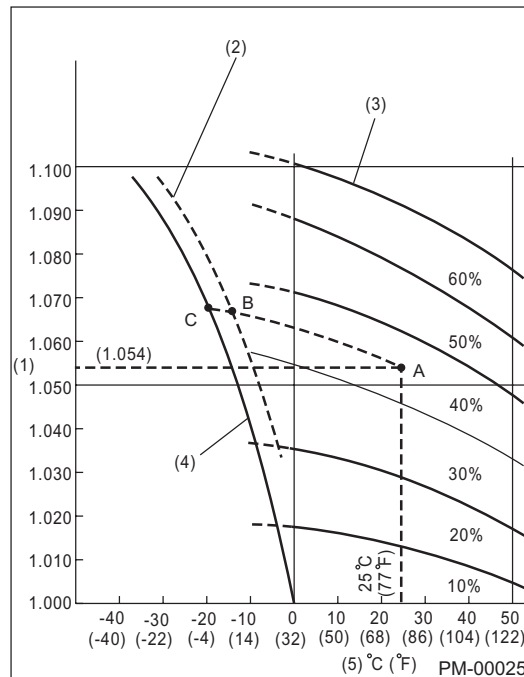

- (1) Coolant gravity
- (2) Safe operating temperature
- (3) Concentration of coolant
- (4) Freezing temperature
- (5) Coolant temperature

RECOMMENDED MATERIALS

RECOMMENDED MATERIALS

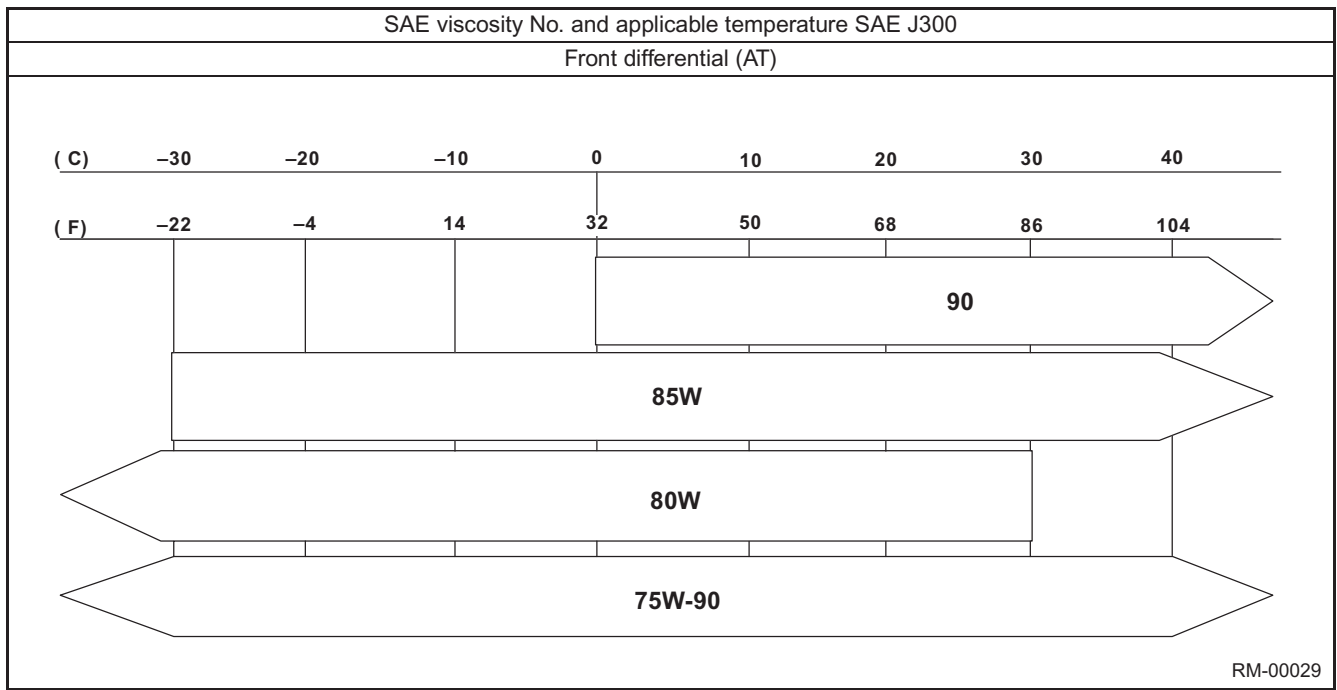

4. FLUID

Use the fluids specified in the table below. Do not mix two different kinds or makes of fluid.

Fluid	Recommended	Alternative	Remarks
Automatic transmission fluid	DEXRON III	—	—
Power steering fluid	DEXRON III	—	—
Brake fluid	FMVSS No. 116 DOT3	FMVSS No. 116 DOT4	—
Clutch fluid	FMVSS No. 116 DOT3	FMVSS No. 116 DOT4	—

5. ENGINE COOLANT

Use genuine engine coolant to protect the engine.

Engine coolant	Recommended	Item number	Alternative
Coolant	SUBARU coolant	000016218	None
Water for dilution	Distilled water	—	Tap water (Soft water)
Coolant Conditioner	Subaru Coolant Conditioner	SOA635071	None

6. REFRIGERANT

Standard air conditioners on Subaru vehicles use HFC134a refrigerant. Do not mix it with other refrigerants. Also, do not use any air compressor oil except for ZXL200PG.

Air conditioner	Recommended	Item number	Alternative
Refrigerant	HFC134a	—	None
Compressor oil	ZXL200PG	—	None

4. Engine Coolant

A: REPLACEMENT

1. DRAINING OF ENGINE COOLANT

- 1) Lift-up the vehicle.
- 2) Remove the under cover.
- 3) Remove the drain cock to drain engine coolant into container.

NOTE:

Remove the coolant filler tank cap so that engine coolant will drain faster.

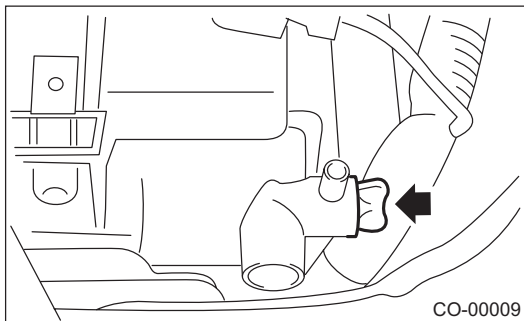

- 4) Install the drain cock.

2. FILLING OF ENGINE COOLANT

- 1) Fill engine coolant into the coolant filler tank up to filler neck position.

Coolant capacity (fill up to "FULL" level):

AT model

Approx. 7.6 ℓ (8.03 US qt, 6.69 Imp qt)

MT model

Approx. 7.7 ℓ (8.14 US qt, 6.78 Imp qt)

CAUTION:

Do not mix up the coolant filler tank side cap with radiator side cap.

NOTE: Do not remove the radiator side cap when filling engine coolant.

- The SUBARU Genuine Coolant containing antifreeze and anti-rust agents is especially made for SUBARU engine, which has an aluminum crankcase. Always use SUBARU Genuine Coolant, since other coolant may cause corrosion.

NOTE: To prevent cooling system leaks, always add Genuine Subaru Cooling System Conditioner (P/N SOA635071) whenever the coolant is replaced.

- 2) Fill engine coolant into the reservoir tank up to Full level.

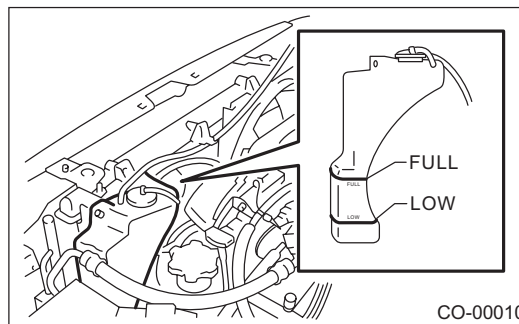

- 3) Warm-up the engine completely for more than 5 minutes at 2,000 to 3,000 rpm.
- 4) If the engine coolant level drops in coolant filler tank, add engine coolant to filler neck position.
- 5) If the engine coolant level drops from Full level of reservoir tank, add engine coolant to Full level.
- 6) Attach the coolant filler tank cap and reservoir tank cap properly.

ENGINE COOLANT

COOLING

4. Engine Coolant

A: REPLACEMENT

1. DRAINING OF ENGINE COOLANT

- 1) Lift-up the vehicle.
- 2) Remove the under cover.
- 3) Remove the drain plug to drain engine coolant into container.

NOTE: Remove the radiator cap so that engine coolant will drain faster.

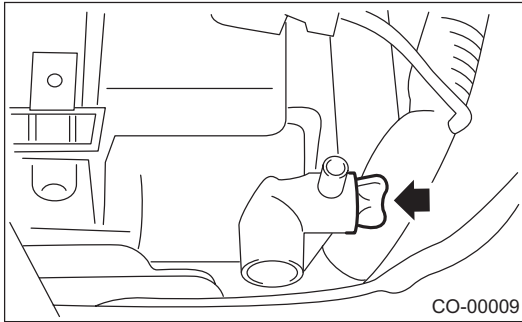

- 4) Install the drain plug.

2. FILLING OF ENGINE COOLANT

- 1) Fill engine coolant into the radiator up to filler neck position.

Coolant capacity (fill up to "FULL" level):

AT model:

Approx. 6.9ℓ (7.29 US qt, 6.07 Imp qt)

MT model:

Approx. 7.0ℓ (7.4 US qt, 6.2 Imp qt)

NOTE: The SUBARU Genuine Coolant containing antifreeze and anti-rust agents is especially made for SUBARU engine, which has an aluminum crankcase. Always use SUBARU Genuine Coolant, since other coolant may cause corrosion.

NOTE: To prevent cooling system leaks, always add Genuine Subaru Cooling System Conditioner (P/N SOA635071) whenever the coolant is replaced.

- 2) Fill engine coolant into the reservoir tank up to Full level.

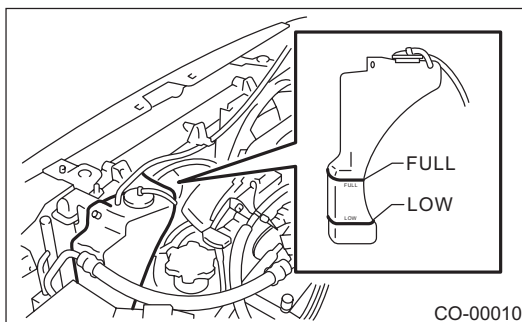

- 3) Warm-up the engine completely for more than 5 minutes at 2,000 to 3,000 rpm.
- 4) If the engine coolant level drops in radiator, add engine coolant to filler neck position.
- 5) If the engine coolant level drops from Full level of reservoir tank, add engine coolant to Full level.
- 6) Attach the radiator cap and reservoir tank cap properly.

B: INSPECTION

1. RELATIONSHIP OF SUBARU COOLANT CONCENTRATION AND FREEZING TEMPERATURE

The concentration and safe operating temperature of the SUBARU coolant is shown in the diagram. Measuring the temperature and specific gravity of the coolant will provide this information.

[Example]

If the coolant temperature is 25°C (77°F) and its specific gravity is 1.054, the concentration is 35% (point A), the safe operating temperature is -14°C (7°F) (point B), and the freezing temperature is -20°C (-4°F) (point C).

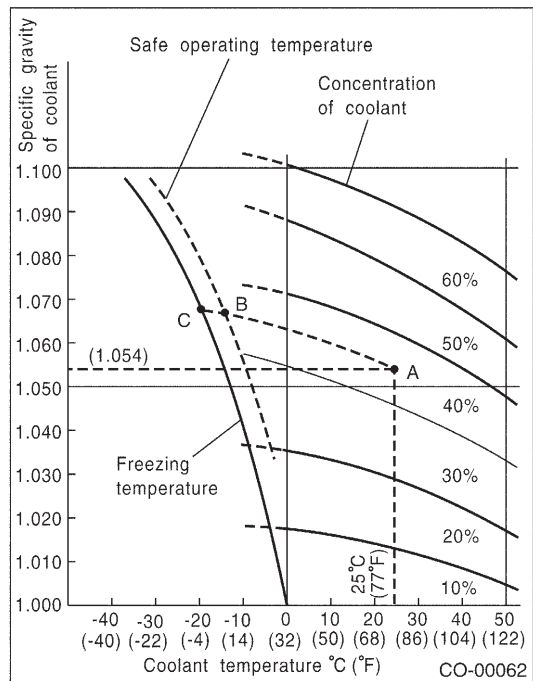

CO(H4SO)-12

replacement page for MSA5T0411A

12. Coolant

A: REPLACEMENT

1. REPLACEMENT OF COOLANT

WARNING: The radiator is of the pressurized type. Do not attempt to open the radiator cap immediately after the engine has been stopped.

- 1) Lift-up the vehicle.
- 2) Remove the under cover.
- 3) Place a container under drain pipe.
- 4) Loosen and remove the drain cock to drain engine coolant into container.

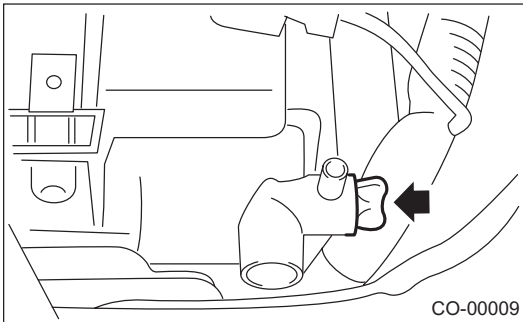

- 5) For quick draining, open the radiator cap.
- NOTE:** In the case of turbo model, be sure to open the radiator cap of filler tank side.
- Be careful not to spill coolant on the floor.
- 6) Drain the coolant from reservoir tank.
- 7) Tighten the radiator drain cock securely after draining coolant.
- 8) Slowly pour the coolant into radiator. Pour the coolant up to air bleeder hole, and then install the cap. (Turbo model)
- 9) Pour the coolant from radiator filler port to neck of filler, then pour into reservoir tank up to "FULL" level.

Coolant capacity (fill up to "FULL" level)

- 2.0 L Turbo AT model:**
Approx. 7.6ℓ (8.0 US qt, 6.7 Imp qt)
- 2.0 L Turbo MT model:**
Approx. 7.7ℓ (8.1 US qt, 6.8 Imp qt)
- 2.5 L AT model:**
Approx. 6.9ℓ (7.3 US qt, 6.1 Imp qt)
- 2.5 L MT model:**
Approx. 7.0ℓ (7.4 US qt, 6.2 Imp qt)
- STi model:**
Approx. 7.7ℓ (8.1 US qt, 6.8 Imp qt)

NOTE: The SUBARU Genuine Coolant containing antifreeze and anti-rust agents is especially made for SUBARU engine, which has an aluminum crankcase. Always use SUBARU Genuine Coolant, since other coolant may cause corrosion.

NOTE: To prevent cooling system leaks, always add Genuine Subaru Cooling System Conditioner (P/N SOA635071) whenever the coolant is replaced.

- 10) Securely install the radiator cap.
- 11) Run the engine for more than 5 minutes at 2,000 to 3,000 rpm. (Run the engine until radiator becomes hot in order to purge the air trapped in cooling system.)
- 12) Stop the engine and wait until coolant temperature lowers. Then open the radiator cap to check coolant level and add coolant up to radiator filler neck. Next, add coolant into reservoir tank up to "FULL" level.
- 13) After adding coolant, securely install the radiator and reservoir tank caps.

2. RELATIONSHIP OF SUBARU COOLANT CONCENTRATION AND FREEZING TEMPERATURE

The concentration and safe operating temperature of the SUBARU coolant is shown in the diagram. Measuring the temperature and specific gravity of the coolant will provide this information.

[Example]

If the coolant temperature is 25°C (77°F) and its specific gravity is 1.054, the concentration is 35% (point A), the safe operating temperature is -14°C (7°F) (point B), and the freezing temperature is -20°C (-4°F) (point C).

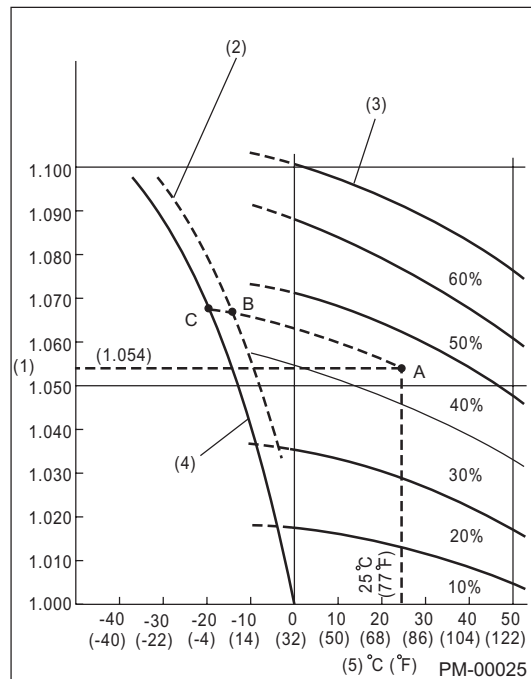

- (1) Coolant gravity
- (2) Safe operating temperature
- (3) Concentration of coolant
- (4) Freezing temperature
- (5) Coolant temperature

RECOMMENDED MATERIALS

RECOMMENDED MATERIALS

4. FLUID

Use the fluids specified in the table below. Do not mix two different kinds or makes of fluid.

Fluid	Recommended	Alternative	Remarks
Automatic transmission fluid	DEXRON III	—	—
Power steering fluid	DEXRON III	—	—
Brake fluid	FMVSS No. 116 DOT3	—	—
Clutch fluid	FMVSS No. 116 DOT3	FMVSS No. 116 DOT4	—

5. COOLANT

Use genuine coolant to protect the engine.

Coolant	Recommended	Item number	Alternative
Coolant	SUBARU coolant	000016218	None
Water for dilution	Distilled water	—	Tap water (Soft water)
Coolant Conditioner	Subaru Coolant Conditioner	SOA635071	None

6. REFRIGERANT

Standard air conditioners on Subaru vehicles use HFC134a refrigerant. Do not mix it with other refrigerants. Also, do not use any compressor oil except for DH-PR.

Air conditioner	Recommended	Item number	Alternative
Refrigerant	HFC134a	—	None
Compressor oil	DH-PR	—	None

3. Engine Coolant

A: REPLACEMENT

1. DRAINING OF ENGINE COOLANT

- 1) Lift-up the vehicle.
- 2) Remove the under cover.
- 3) Remove the drain cock to drain engine coolant into container.

NOTE:

Remove the coolant filler tank cap so that engine coolant will drain faster.

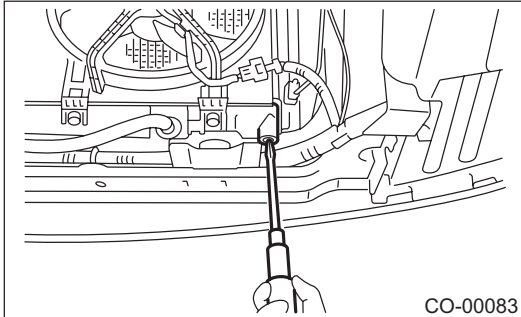

- 4) Install the drain cock.

2. FILLING OF ENGINE COOLANT

- 1) Fill engine coolant into the coolant filler tank up to filler neck position.

Coolant capacity (fill up to "FULL" level):

AT model

Approx. 7.6ℓ (8.03 US qt, 6.69 Imp qt)

MT model

Approx. 7.7ℓ (8.14 US qt, 6.78 Imp qt)

CAUTION: Do not mix up the coolant filler tank side cap with radiator side cap.

NOTE:

- Do not remove the radiator side cap when filling engine coolant.
- The SUBARU Genuine Coolant containing antifreeze and anti-rust agents is especially made for SUBARU engine, which has an aluminum crankcase. Always use SUBARU Genuine Coolant, since other coolant may cause corrosion.
- To prevent cooling system leaks, always add Genuine Subaru Cooling System Conditioner (P/N SOA635071) whenever the coolant is replaced.

- 2) Fill engine coolant into the reservoir tank up to Full level.

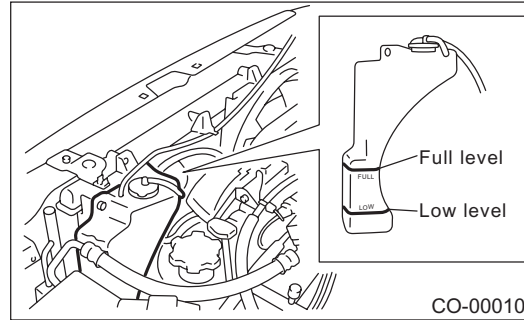

- 3) Warm-up the engine completely for more than 5 minutes at 2,000 to 3,000 rpm.
- 4) If the engine coolant level drops in coolant filler tank, add engine coolant to filler neck position.
- 5) If the engine coolant level drops from Full level of reservoir tank, add engine coolant to Full level.
- 6) Attach the coolant filler tank cap and reservoir tank cap properly.

4. Engine Coolant

A: REPLACEMENT

1. DRAINING OF ENGINE COOLANT

- 1) Lift-up the vehicle.
- 2) Remove under cover.

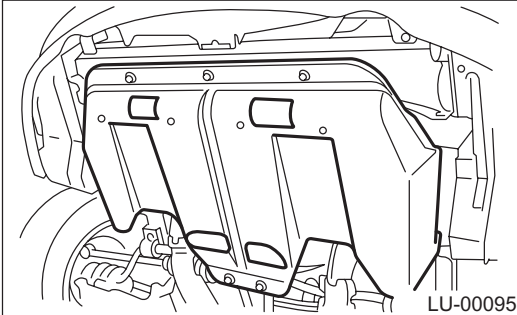

- 3) Remove drain cock to drain engine coolant from radiator.

NOTE:

Remove radiator cap so that engine coolant will drain faster.

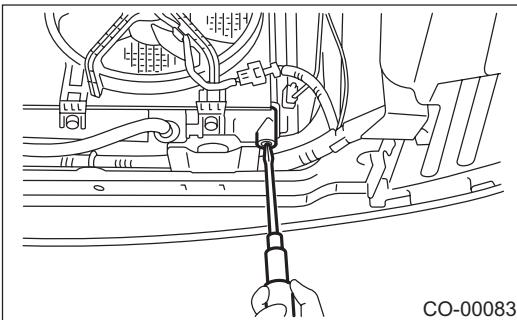

2. FILLING OF ENGINE COOLANT

- 1) Fill engine coolant into radiator up to filler neck position.

Engine coolant amount for refill:

MT model;

Approx. 6.8ℓ (7.2 US qt, 6.0 Imp qt)

AT model;

Approx. 6.7ℓ (7.1 US qt, 5.9 Imp qt)

CAUTION:

The SUBARU Genuine Coolant containing antifreeze and anti-rust agents is especially made for SUBARU engine, which has an aluminum crankcase. Always use SUBARU Genuine Coolant, since other coolant may cause corrosion.

NOTE: To prevent cooling system leaks, always add Genuine Subaru Cooling System Conditioner (P/N SOA635071) whenever the coolant is replaced.

- 2) Fill engine coolant into reservoir tank up to upper level.

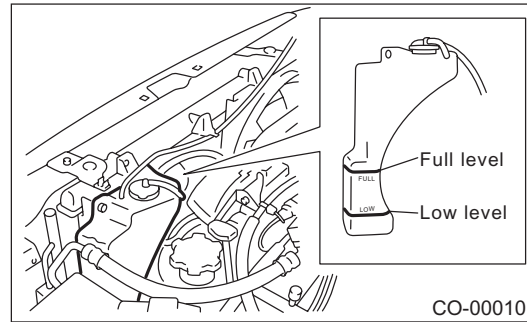

- 3) Attach radiator cap and reservoir tank cap properly.
- 4) Warm-up engine completely for more than five minutes at 2,000 to 3,000 rpm.
- 5) If engine coolant level drops in radiator, add engine coolant to filler neck position.
- 6) If engine coolant level drops from upper level of reservoir tank, add engine coolant to upper level.
- 7) Attach radiator cap and reservoir tank cap properly.

4. Engine Coolant

A: REPLACEMENT

1. DRAINING OF ENGINE COOLANT

- 1) Lift-up the vehicle.
- 2) Remove under cover.

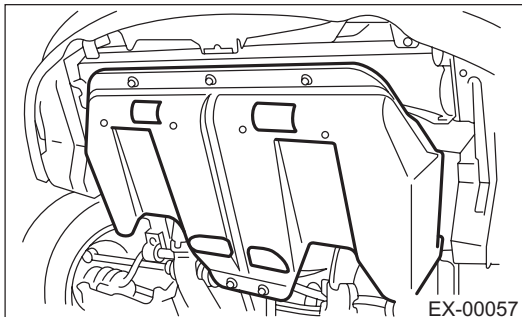

- 3) Remove drain cock to drain engine coolant into container.

NOTE: Remove radiator cap so that engine coolant will drain faster.

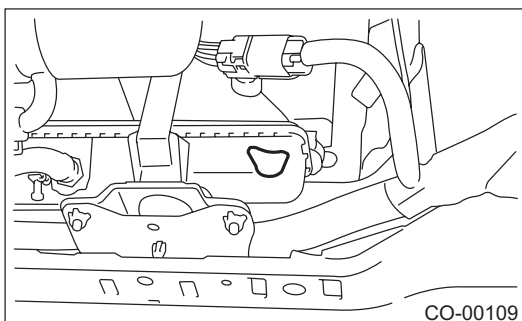

2. FILLING OF ENGINE COOLANT

- 1) Fill engine coolant into radiator up to filler neck position.

Coolant amount for refill:

Approx. 7.9ℓ (8.4 US qt, 7.0 Imp qt)

CAUTION: The SUBARU Genuine Coolant containing antifreeze and anti-rust agents is especially made for SUBARU engine, which has an aluminum crankcase. Always use SUBARU Genuine Coolant, since other coolant may cause corrosion.

NOTE: To prevent cooling system leaks, always add Genuine Subaru Cooling System Conditioner (P/N SOA635071) whenever the coolant is replaced.

- 2) Fill engine coolant into reservoir tank up to upper level.

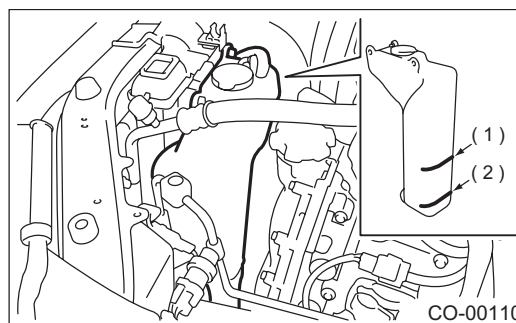

- (1) Full level
- (2) Low level

- 3) Attach radiator cap and reservoir tank cap properly.
- 4) Warm-up engine completely for more than five minutes at 2,000 to 3,000 rpm.
- 5) If engine coolant level drops in radiator, add engine coolant to filler neck position.
- 6) If engine coolant level drops from upper level of reservoir tank, add engine coolant to upper level.
- 7) Attach radiator cap and reservoir tank cap properly.

12. Coolant

A: REPLACEMENT

1. REPLACEMENT OF COOLANT

WARNING:

The radiator is of the pressurized type. Do not attempt to open the radiator cap immediately after the engine has been stopped.

- 1) Lift up the vehicle.
- 2) Remove under cover.
- 3) Place a container under drain pipe.
- 4) Loosen and remove drain screw to drain engine coolant into container.

2.5 L model

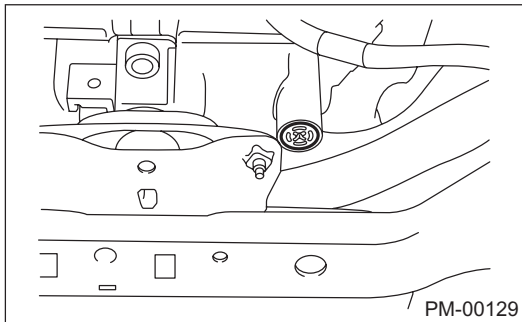

3.0 L model

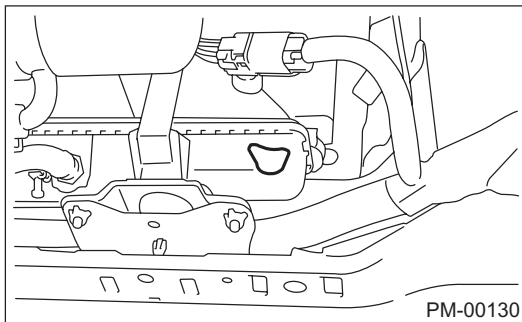

- 5) For quick draining, open radiator cap.

CAUTION:

Be careful not to spill coolant on the floor.

- 6) Drain coolant from reservoir tank.
- 7) Tighten radiator drain screw securely after draining coolant.

- 8) Slowly pour prepared coolant from radiator filler port to neck of filler, then pour into reservoir tank up to "FULL" level.

Coolant amount for preparation

2.5 L Non-TURBO model

MT model:

Approx. 6.8ℓ (7.2 US qt, 6.0 Imp qt)

AT model:

Approx. 6.7ℓ (7.1 US qt, 5.9 Imp qt)

2.5 L TURBO model

MT model:

Approx. 7.4ℓ (7.8 US qt, 6.5 Imp qt)

AT model:

Approx. 7.3ℓ (7.7 US qt, 6.4 Imp qt)

3.0 L model

Approx. 7.9ℓ (8.4 US qt, 7.0 Imp qt)

NOTE: The SUBARU Genuine Coolant containing antifreeze and anti-rust agents is especially made for SUBARU engine, which has an aluminum crankcase. Always use SUBARU Genuine Coolant, since other coolant may cause corrosion.

NOTE: To prevent cooling system leaks, always add Genuine Subaru Cooling System Conditioner (P/N SOA635071) whenever the coolant is replaced.

- 9) Securely install radiator cap.
- 10) Run engine for more than five minutes at 2,000 to 3,000 rpm. (Run engine until radiator becomes hot in order to purge air trapped in cooling system.)
- 11) Stop engine and wait until coolant temperature lowers. Then open radiator cap to check coolant level and add coolant up to radiator filler neck. Next, add coolant into reservoir tank up to "FULL" level.
- 12) After adding coolant, securely install radiator and reservoir tank caps.

RECOMMENDED MATERIALS

RECOMMENDED MATERIALS

SAE viscosity No. and applicable temperature SAE J300								
AT front differential gear oil								
(°C)	Ð30	Ð20	Ð10	0	10	20	30	40
(°F)	Ð22	Ð4	14	32	50	68	86	104
								90
								85W
								80W
								75W-90

RM-00031

4. FLUID

Use the fluids specified in the table below. Do not mix two different kinds or makes of fluid.

Fluid	Recommended	Alternative	Remarks
Automatic transmission fluid	DEXRON III	—	—
Power steering fluid	DEXRON III	—	—
Brake fluid	FMVSS No. 116 DOT3	FMVSS No. 116 DOT4	—
Clutch fluid	FMVSS No. 116 DOT3	FMVSS No. 116 DOT4	—

5. COOLANT

Use genuine coolant to protect the engine.

Coolant	Recommended	Item number	Alternative
Coolant	SUBARU coolant	000016218	None
Water for dilution	Distilled water	—	Tap water
Coolant Conditioner	Subaru Coolant Conditioner	SOA635071	None

6. REFRIGERANT

Standard air conditioners on Subaru vehicles use HFC134a refrigerant. Do not mix it with other refrigerants. Also, do not use any air compressor oil except for ZXL200PG.

Air conditioner	Recommended	Item number	Alternative
Refrigerant	HFC134a	—	None
Compressor oil	ZXL200PG	—	None