

TURN SIGNAL LIGHT AND HAZARD LIGHT SYSTEM

WIRING SYSTEM

29. Turn Signal Light and Hazard Light System

A: WIRING DIAGRAM

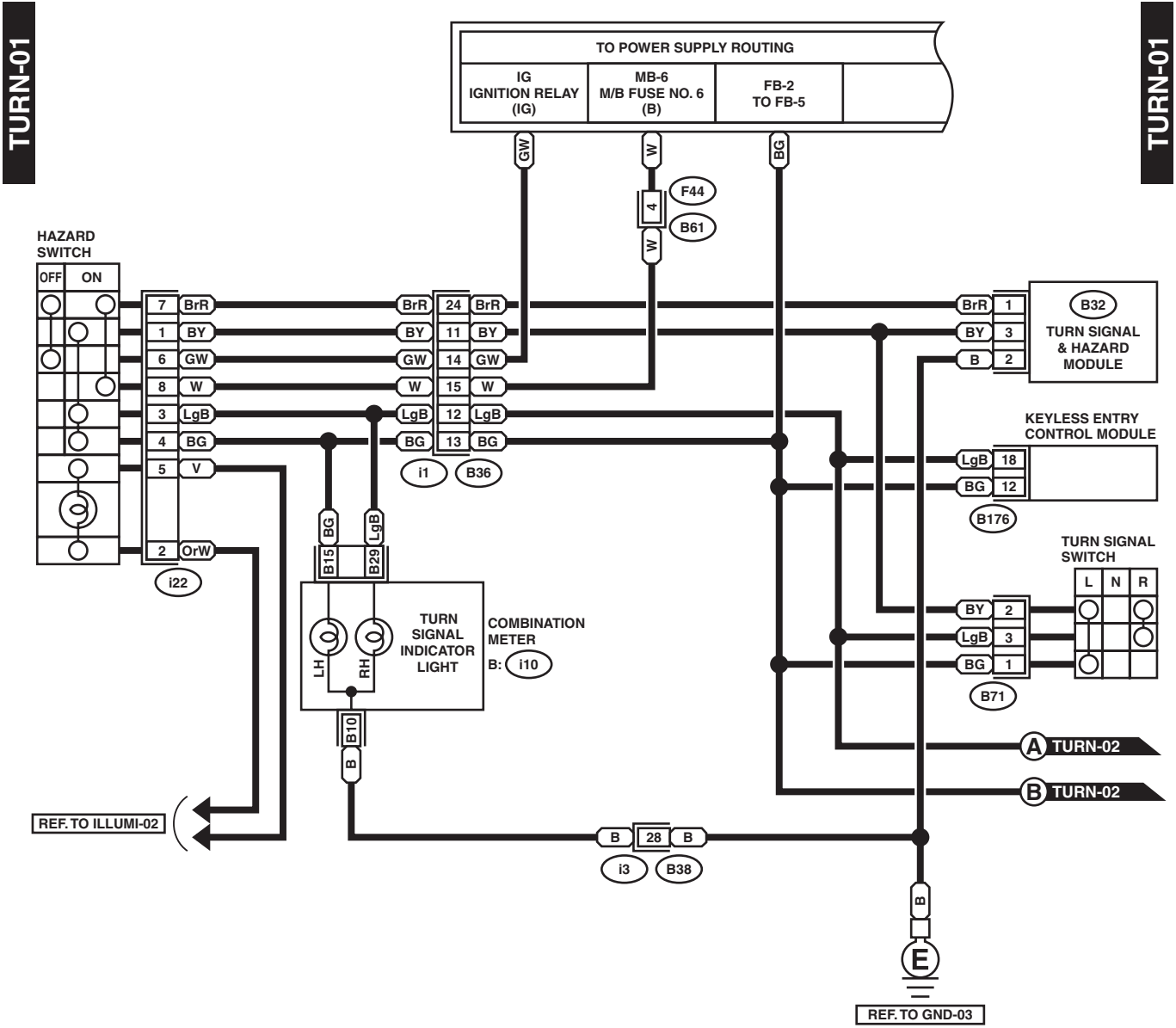

B32 (BLACK)



F44



i22



B71

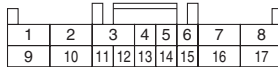

B176

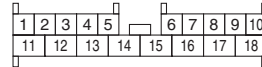

B36

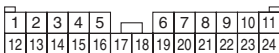

B: i10 (GREEN)

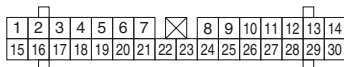

B38



WI-03075

TURN SIGNAL LIGHT AND HAZARD LIGHT SYSTEM

WIRING SYSTEM

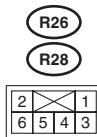
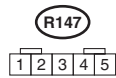
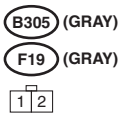
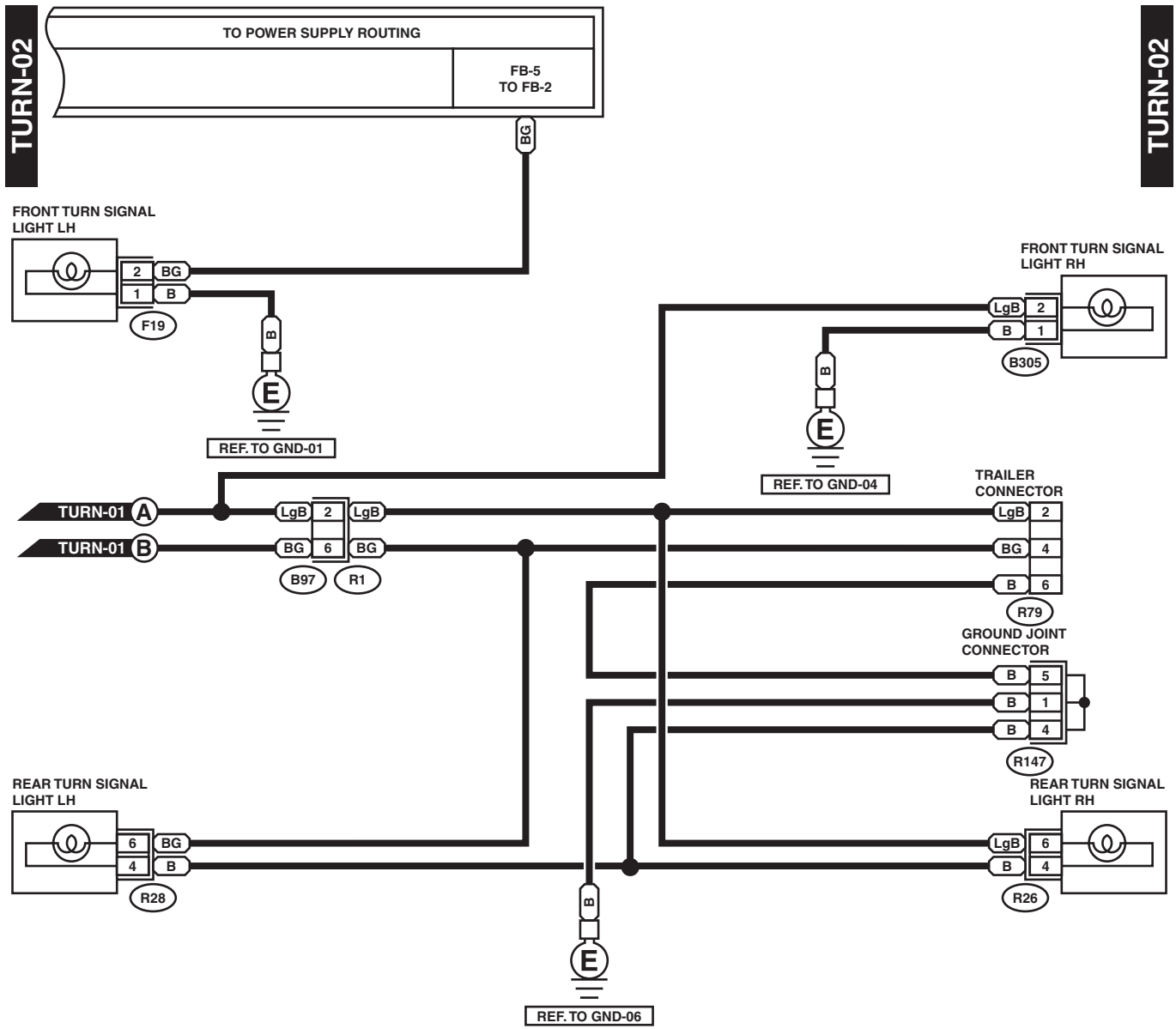

WI-03076