

## 9. Fuel Filter

### A: REPLACEMENT

**WARNING:**

- Place “NO FIRE” signs near the working area.
- Be careful not to spill fuel on the floor.

**NOTE:**

The fuel filter is built in fuel pump assembly.

- 1) Release the fuel pressure.  
<Ref. to FU(H4SO)-48, OPERATION, Fuel.>
- 2) Remove the fuel pump assembly.  
<Ref. to FU(H4SO)-66, REMOVAL, Fuel Pump.>
- 3) Disconnect the ground cable from filter holder.

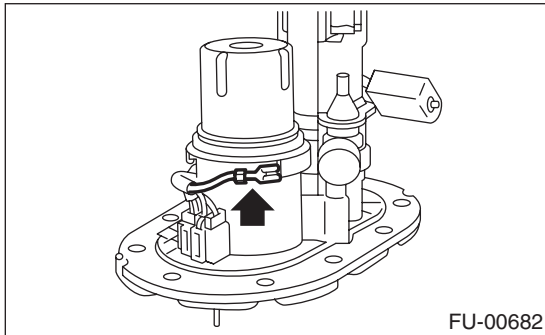

- 4) Remove the filter holder by turning it to the left from the body pawls, and then take out the filter.

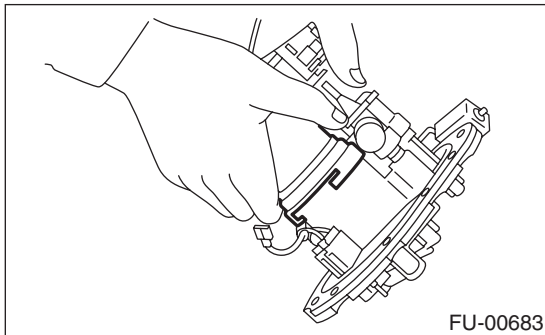

### B: INSTALLATION

**CAUTION:**

- If the fuel hoses are damaged at the connecting portion, replace it with a new one.
- If the clamps are badly damaged, replace with new ones.
- Replace the o-ring with new ones.

- 1) Set the O-ring on the filter holder, and then install by turning to the right.

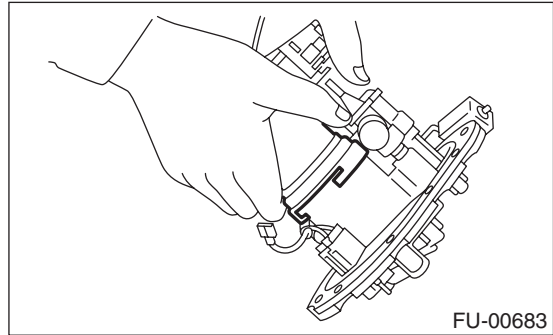

- 2) Connect the ground cable to filter holder.

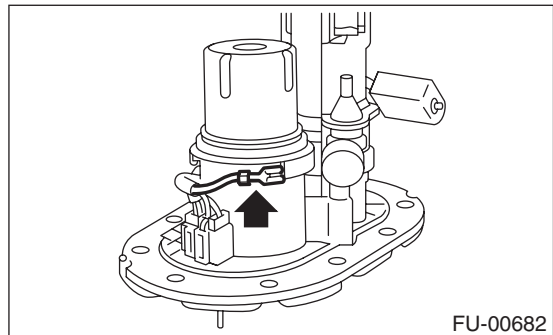

- 3) Install the fuel pump assembly.  
<Ref. to FU(H4SO)-67, INSPECTION, Fuel Pump.>

### C: INSPECTION

- 1) Check the inside of fuel filter for dirt and water sediment.
- 2) If it is clogged, or if replacement interval has been reached, replace it.