

10. Radiator Sub Fan and Fan Motor

A: REMOVAL

- 1) Disconnect battery ground cable.

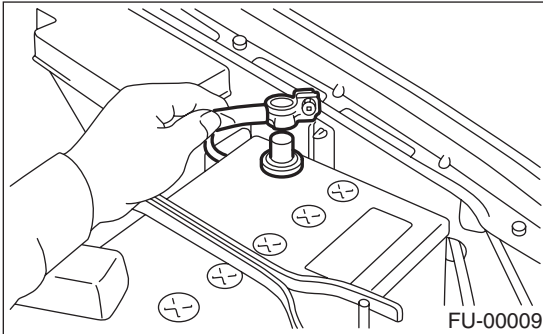

- 2) Lift-up the vehicle.
- 3) Remove under cover.

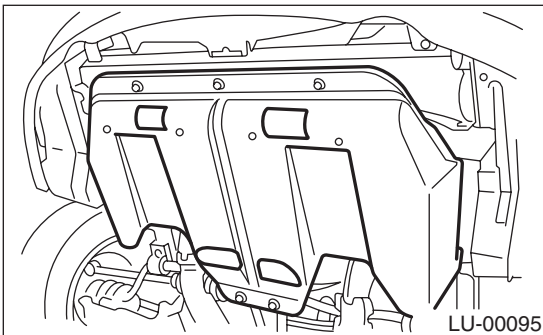

- 4) Disconnect connector of sub fan motor.

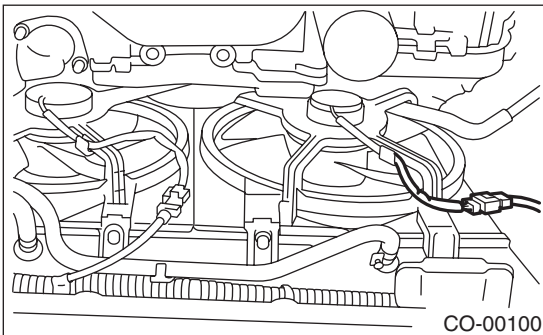

- 5) Lower the vehicle.
- 6) Remove air intake duct.

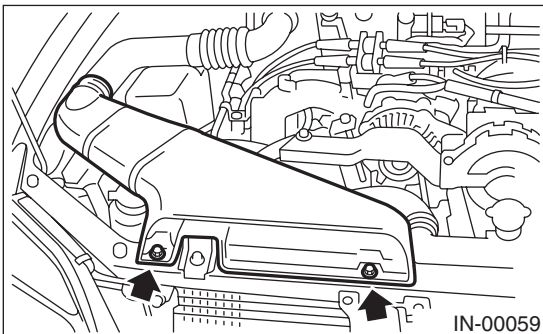

- 7) Remove bolts which hold sub fan shroud to radiator.
- 8) Remove radiator sub fan shroud through the under side of vehicle.

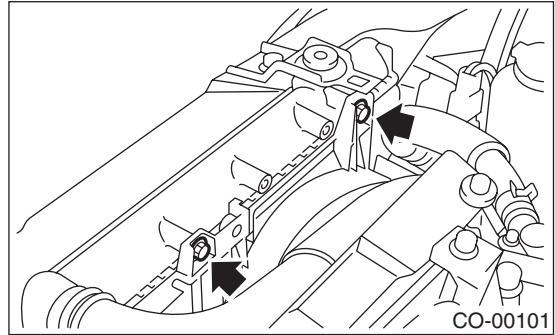

B: INSTALLATION

Install in the reverse order of removal.

Tightening torque:

4.9 N·m (0.50 kgf·m, 3.6 ft·lb)

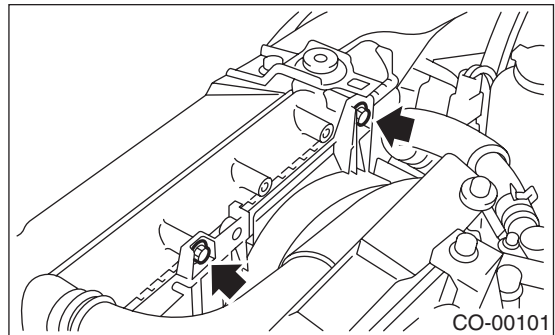

C: DISASSEMBLY

- 1) Remove clip which holds motor harness onto shroud.

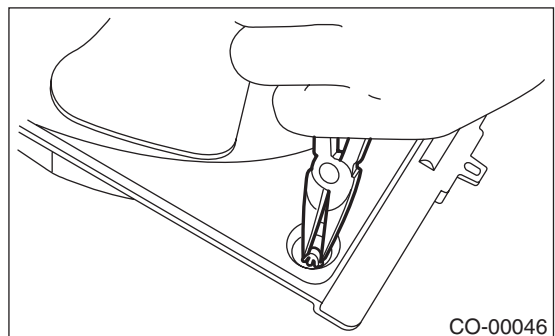

RADIATOR SUB FAN AND FAN MOTOR

COOLING

2) Remove nut which holds fan itself onto fan motor and shroud assembly.

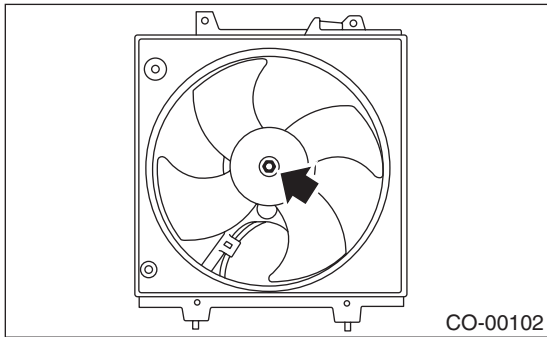

3) Remove bolts which install fan motor onto shroud.

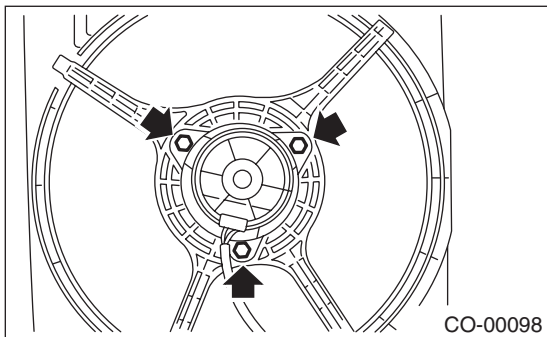

D: ASSEMBLY

Assemble in the reverse order of disassembly.

Tightening torque:

4.4 N·m (0.45 kgf·m, 3.3 ft·lb)

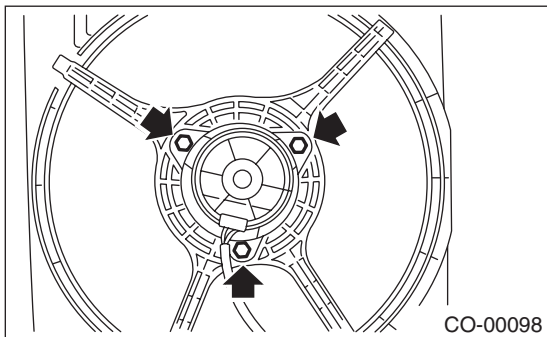

Tightening torque:

3.4 N·m (0.35 kgf·m, 2.5 ft·lb)

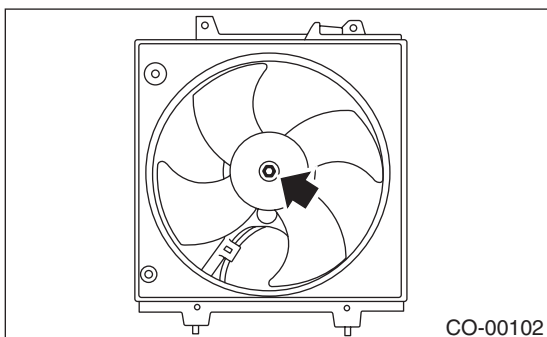

E: INSPECTION

1) Connect battery positive (+) terminal to terminal No. 2, and negative (-) terminal to terminal No. 1 of sub fan motor connector.

2) Make sure the sub-fan motor operates properly. Replace it if it doesn't.

