

17.Engine Control Module

A: REMOVAL

- 1) Disconnect ground cable from battery.

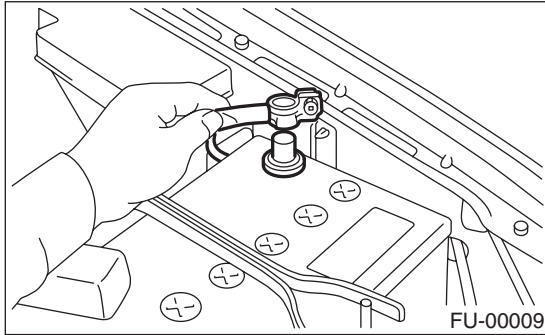

- 2) Remove lower inner trim of passenger side.
<Ref. to EI-42, REMOVAL, Lower Inner Trim.>
- 3) Detach floor mat of passenger seat.
- 4) Remove protect cover.

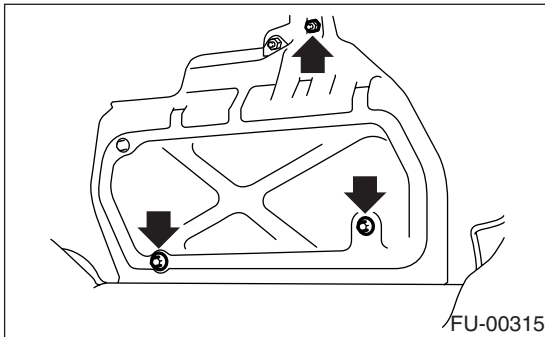

- 5) Remove nuts (A) which hold ECM to bracket.
- 6) Remove clip (B) from bracket.

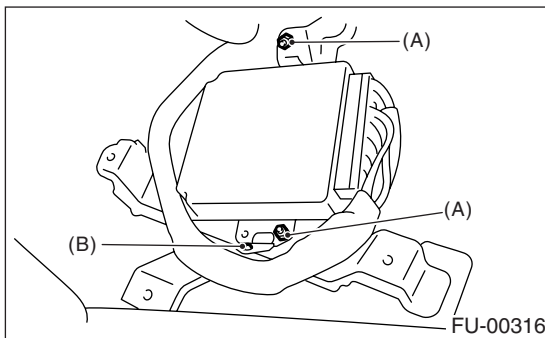

- 7) Disconnect ECM connectors and take out ECM.

B: INSTALLATION

Install in the reverse order of removal.

CAUTION:

When replacing ECM, be careful not to use the wrong spec. ECM to avoid any damage to the fuel injection system.

Tightening torque:

5 N·m (0.51 kgf-m, 3.7 ft-lb)