

THROTTLE BODY

FUEL INJECTION (FUEL SYSTEMS)

2. Throttle Body

A: REMOVAL

1) Disconnect ground cable from battery.

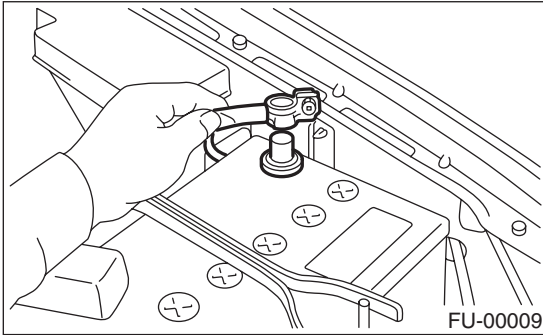

- 2) Remove air cleaner case.
<Ref. to IN(H4SO)-5, REMOVAL, Air Cleaner.>
- 3) Disconnect accelerator cable (A).
- 4) Disconnect cruise control cable (B). (With cruise control model)

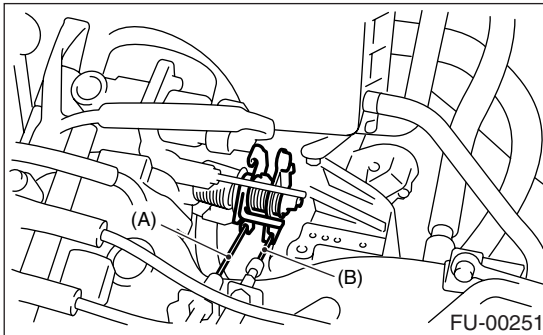

- 5) Disconnect connectors from idle air control solenoid valve, throttle position sensor and pressure sensor.
- 6) Disconnect air by-pass hose from throttle body.

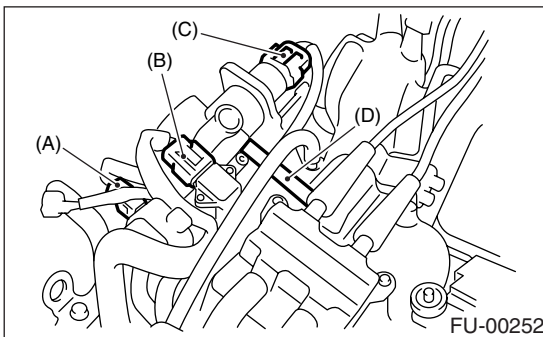

- (A) Throttle position sensor
- (B) Pressure sensor
- (C) Idle air control solenoid valve
- (D) Air by-pass hose

7) Disconnect engine coolant hoses (A) from throttle body.

8) Remove bolts (B) which install throttle body to intake manifold.

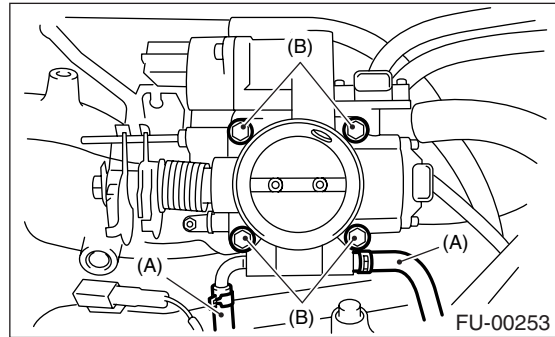

B: INSTALLATION

- 1) Install in the reverse order of removal.
- 2) Install accelerator cable.
<Ref. to SP(H4SO)-6, INSTALLATION, Accelerator Control Cable.>

NOTE:

Always use a new gasket.

Tightening torque:

Throttle body;

22 N·m (2.2 kgf-m, 15.9 ft-lb)