

# FUEL

## FUEL INJECTION (FUEL SYSTEMS)

### 20. Fuel

#### A: OPERATION

##### 1. RELEASING OF FUEL PRESSURE

###### WARNING:

- Place “NO FIRE” signs near the working area.
- Be careful not to spill fuel on the floor.

- 1) Disconnect connector from fuel pump relay.

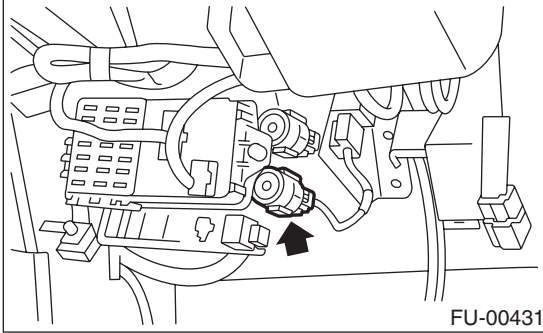

- 2) Start the engine and run it until it stalls.
- 3) After the engine stalls, crank it for five more seconds.
- 4) Turn ignition switch to OFF.

##### 2. DRAINING FUEL

###### WARNING:

- Place “NO FIRE” signs near the working area.
- Be careful not to spill fuel on the floor.

- 1) Set vehicle on the lift.
- 2) Disconnect battery ground cable.

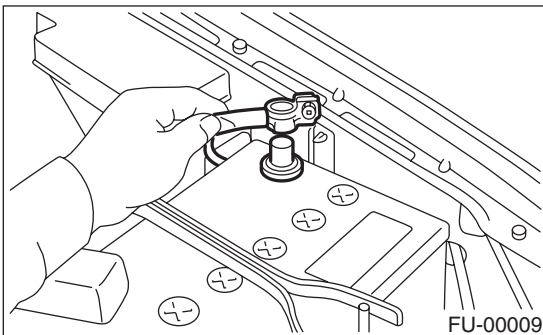

- 3) Lift-up the vehicle.
- 4) Remove front right side fuel tank cover.

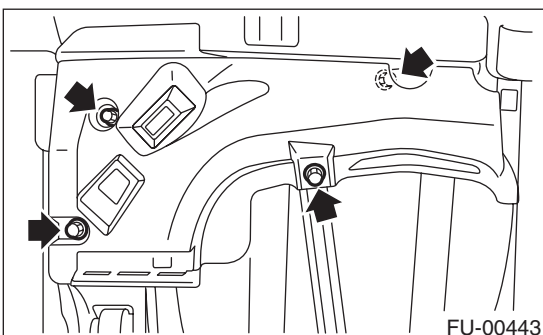

- 5) Drain fuel from fuel tank.  
Set a container under the vehicle and remove drain plug from fuel tank.

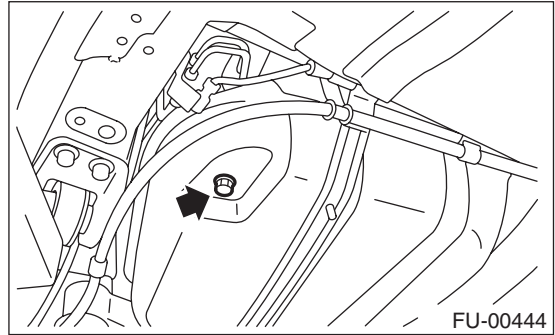

- 6) Tighten fuel drain plug and install front right side tank cover.

**Tightening torque:**  
**26 N·m (2.65 kgf·m, 19.2 ft·lb)**

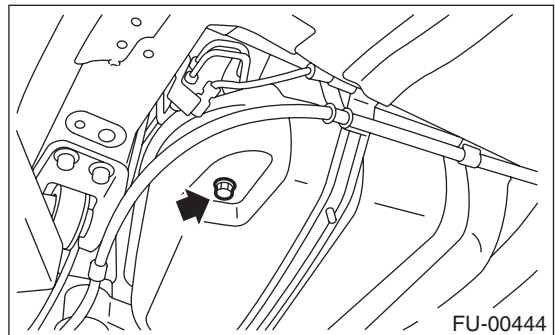

**Tightening torque:**  
**18 N·m (1.8 kgf·m, 13.0 ft·lb)**

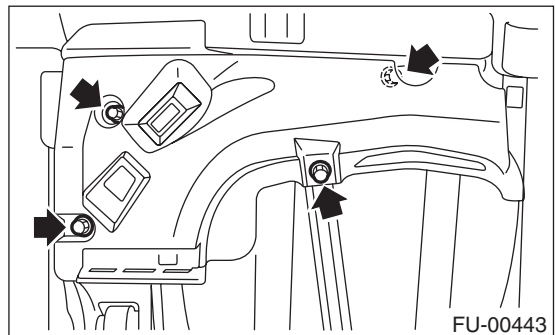

- 7) Lower the vehicle.

# FUEL

## FUEL INJECTION (FUEL SYSTEMS)

8) Remove sub service hole cover.

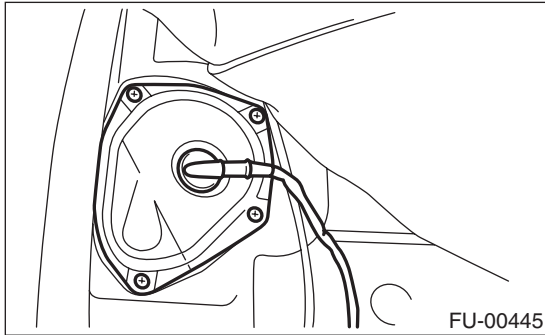

9) Disconnect connector from fuel sub level sensor.

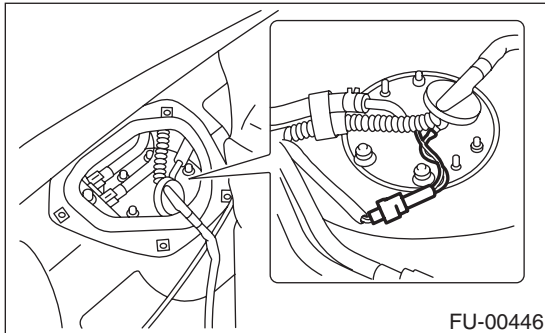

10) Disconnect fuel jet pump hose.

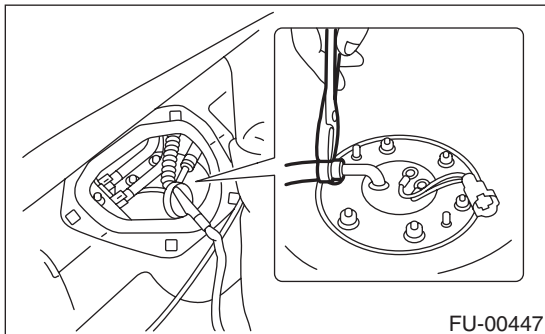

11) Remove fuel sub level sensor.

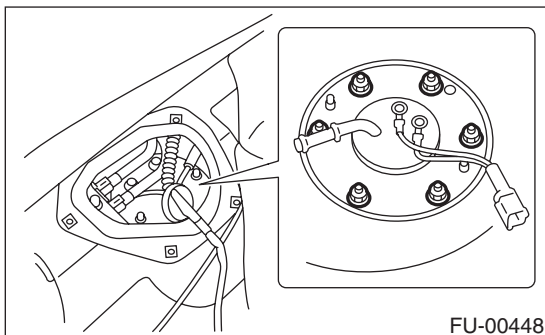

12) Drain fuel from fuel tank by using hand pump.

### WARNING:

**Do not use a motor pump when draining fuel.**

13) After draining fuel, reinstall fuel sub level sensor.

### Tightening torque:

**T: 4.4 N·m (0.45 kgf·m, 3.3 ft-lb)**

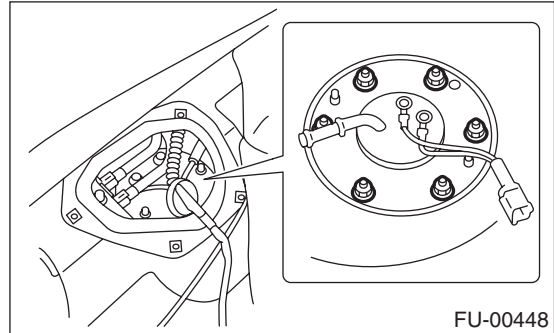

### NOTE:

If you have not removed fuel tank yet, proceed with the procedure below for installation.

(1) Connect fuel jet pump hose.

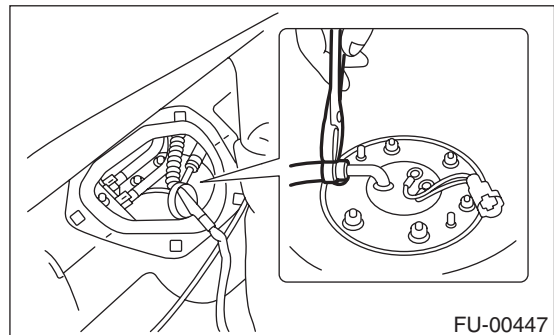

(2) Connect connector from fuel sub level sensor.

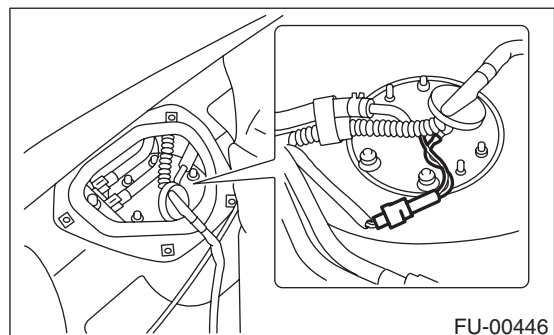

# FUEL

## FUEL INJECTION (FUEL SYSTEMS)

---

- (3) Install sub service hole cover.

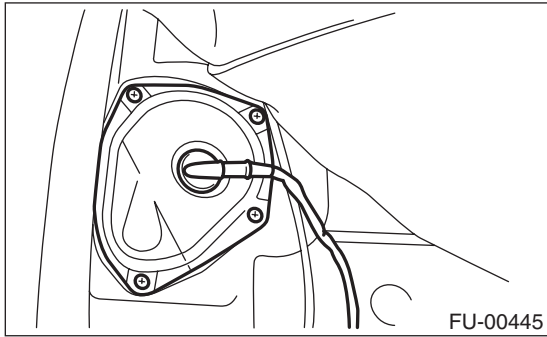

- (4) Set rear seat and floor mat.