

## 25. Fuel Sub Level Sensor

### A: REMOVAL

#### WARNING:

- Place “NO FIRE” signs near the working area.
- Be careful not to spill fuel on the floor.
- During work procedures, if fuel tank is more than 3/4 full, be careful because fuel may spill.

- 1) Drain fuel from fuel tank.  
<Ref. to FU(H4SO)-48, DRAINING FUEL, OPERATION, Fuel.>
- 2) Remove rear seat.
- 3) Remove service hole cover.

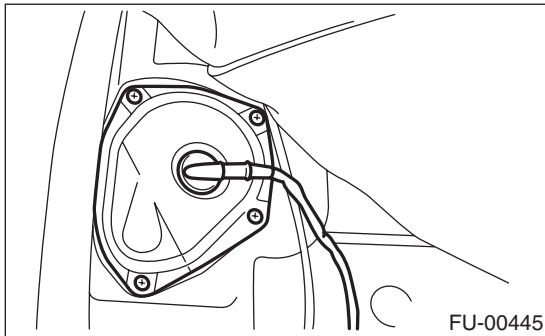

- 4) Disconnect connector from fuel sub level sensor.

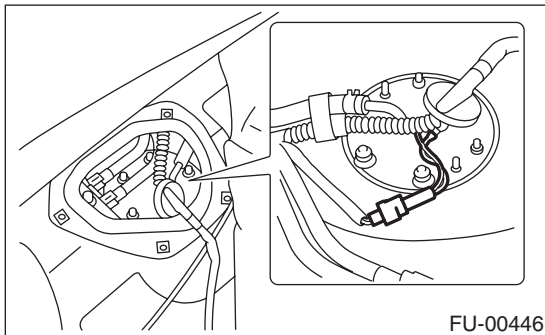

- 5) Disconnect fuel jet pump hose.

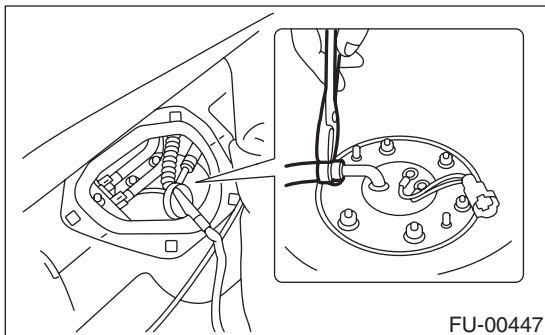

- 6) Remove bolts which install fuel sub level sensor on fuel tank.

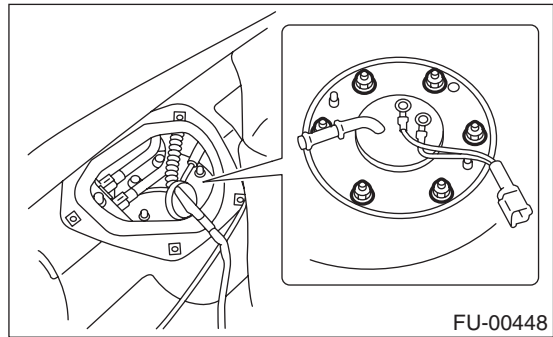

- 7) Remove fuel sub level sensor.

### B: INSTALLATION

Install in the reverse order of removal.

#### Tightening torque:

**4.4 N·m (0.45 kgf·m, 3.3 ft·lb)**

