

2. Starter

A: REMOVAL

1) Disconnect ground cable from battery.

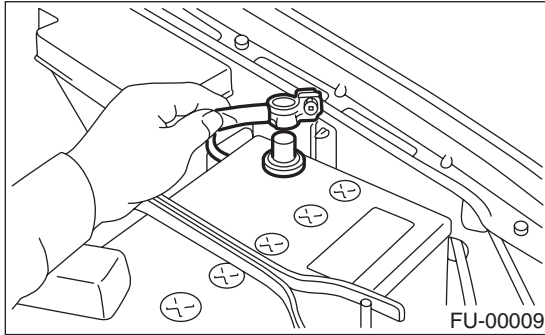

2) Remove air cleaner case. (Non-Turbo model)
<Ref. to IN(H4SO)-6, REMOVAL, Air Cleaner Case.>

3) Remove intercooler. (Turbo model)
<Ref. to IN(H4DOTC)-10, REMOVAL, Intercooler.>

4) Remove air cleaner case stay.
• MT vehicles

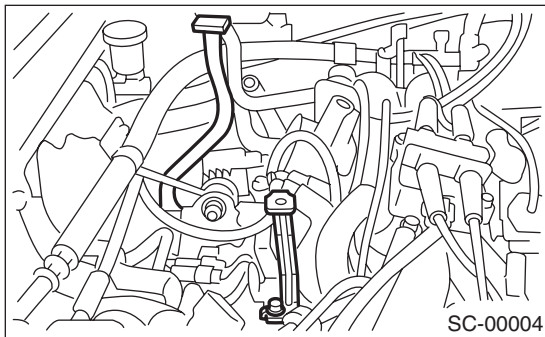

• AT vehicles

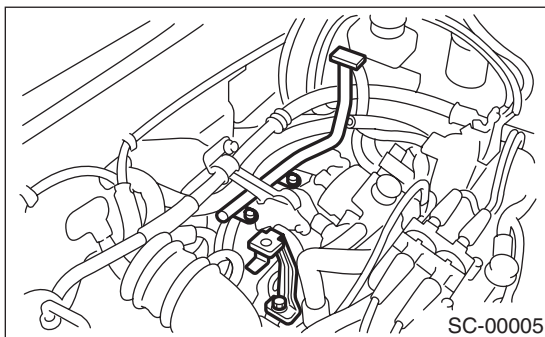

5) Disconnect connector and terminal from starter.

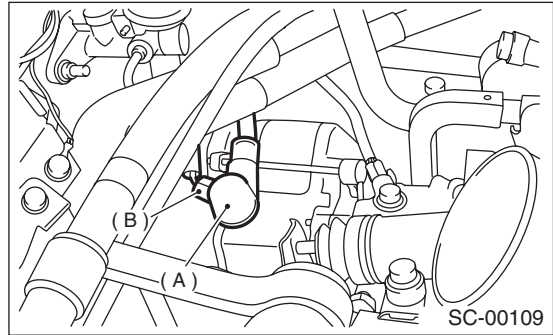

(A) Terminal
(B) Connector

6) Remove starter from transmission.

B: INSTALLATION

Install in the reverse order of removal.

Tightening torque:

50 N·m (5.1 kgf-m, 37 ft-lb)

C: DISASSEMBLY

1) Disconnect lead wire (A) from magnetic switch (B).

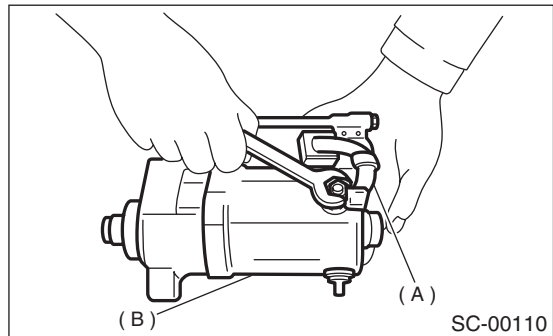

2) Remove through-bolts (A) from end frame (B).

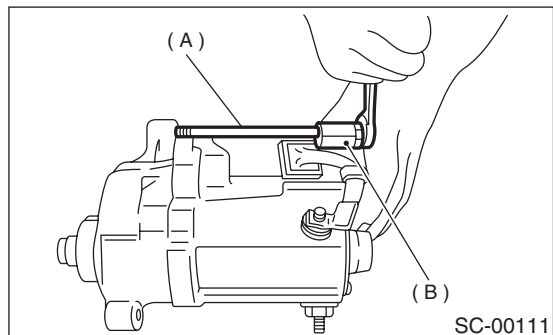

STARTER

STARTING/CHARGING SYSTEMS

3) Remove yoke (A) from magnetic switch (B).

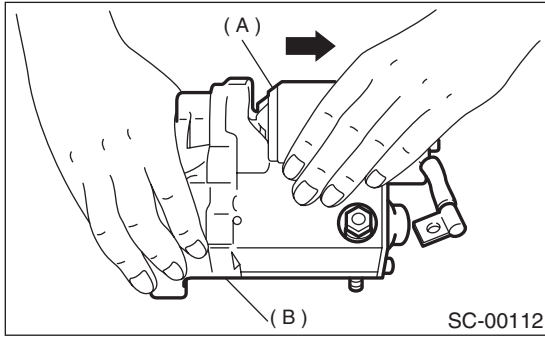

7) Remove armature (A) from yoke (B).

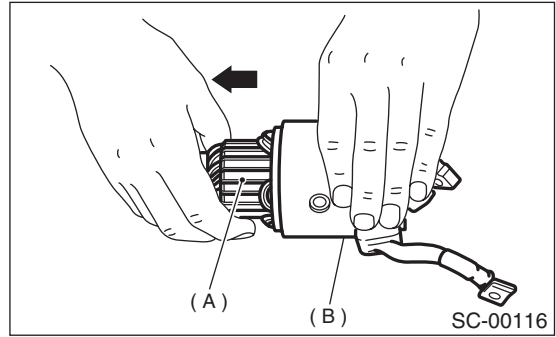

4) Remove screws (A) securing brush holder to end frame (B).

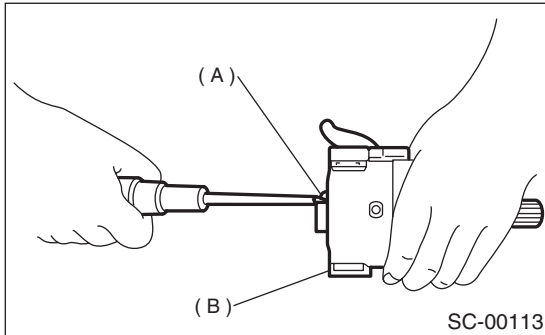

8) Remove screws securing magnetic switch (A) to housing (B).

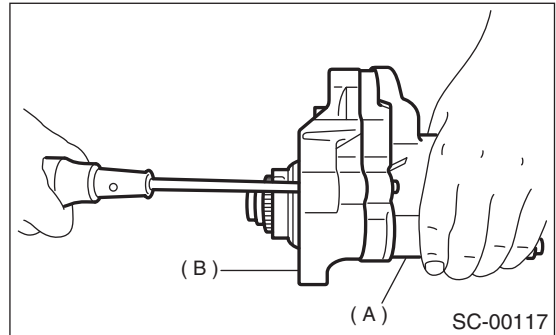

5) Separate yoke (A) from end frame (B).

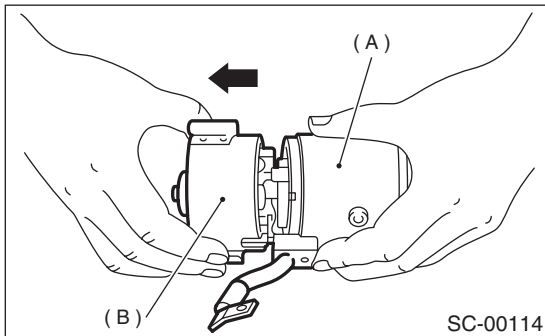

9) Remove housing (A) from magnetic switch (B).

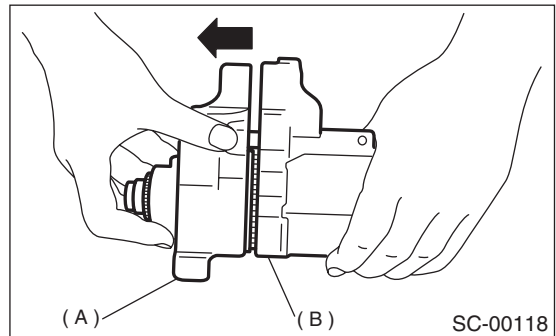

6) Remove brush (A) by lifting up positive (+) side brush spring (B) using long-nose pliers.

CAUTION:
Be careful not to damage brush and commutator.

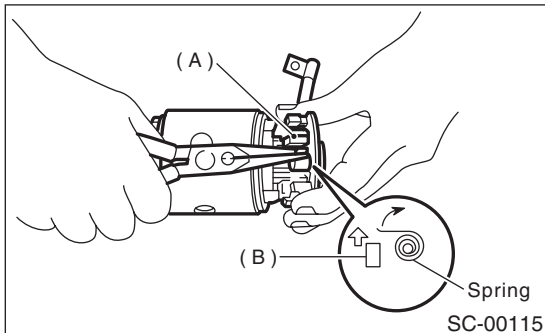

10) Remove clutch (A) from housing (B).

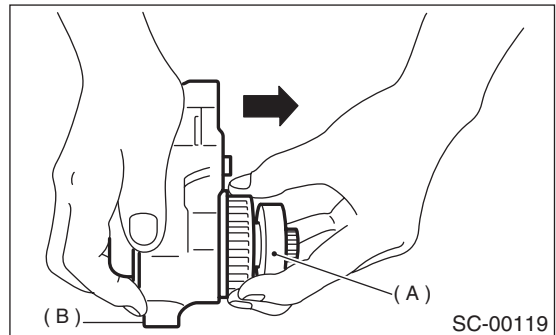

11) Take out steel ball (A) from clutch (B).

CAUTION:

Be careful not to lose steel ball.

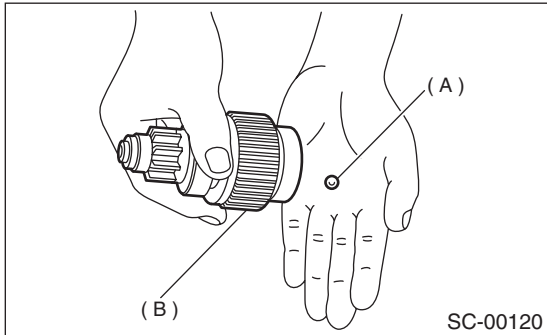

12) Remove idle gear (A) from housing.

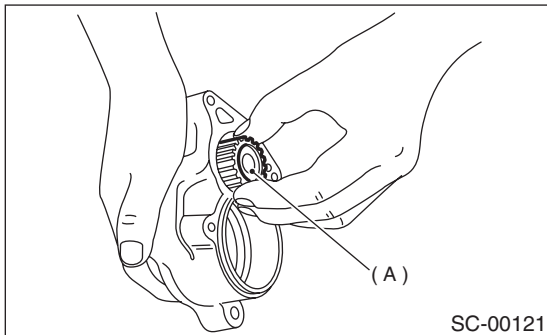

13) Remove retainer and roller (A) from housing.

CAUTION:

Be careful not to drop retainer and roller.

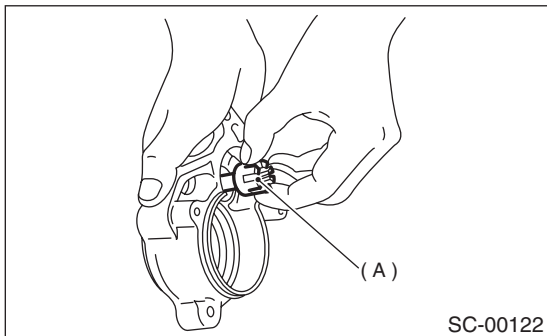

14) Remove coil spring (A) from magnetic switch (B).

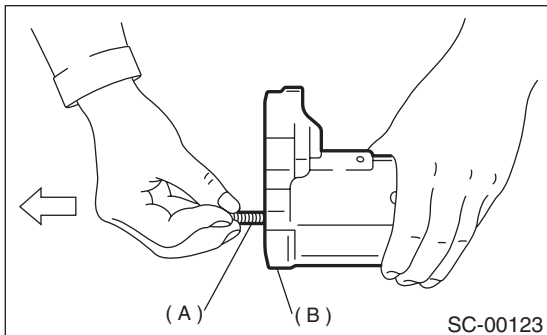

D: ASSEMBLY

Assemble in the reverse order of disassembly. Observe the following:

1) Before assembling, apply grease to the points shown in "COMPONENT PARTS". <Ref. to SC(H4SO)-3, COMPONENT, General Description.>

2) Assembling magnetic switch, clutch, and housing

To assemble, first install clutch to magnetic switch, then install idle gear, and finally install clutch.

CAUTION:

- Do not forget to install steel ball and coil spring to clutch.
- Attach bearing to idle gear beforehand.

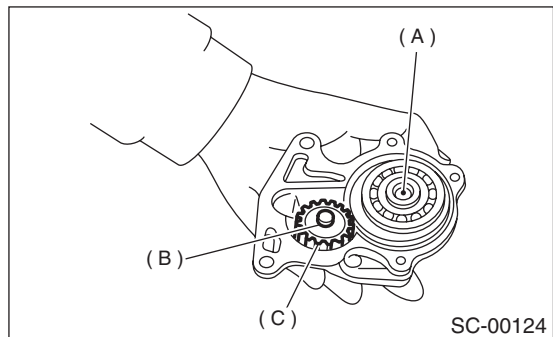

- (A) Steel ball
- (B) Retainer
- (C) Idle gear

3) Installing armature (A) to yoke (B)

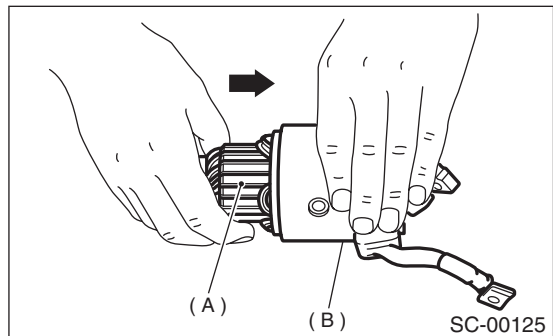

STARTER

STARTING/CHARGING SYSTEMS

4) Installing brushes

Assemble brush holder to yoke as shown, then assemble two yoke-side brushes to brush holder.

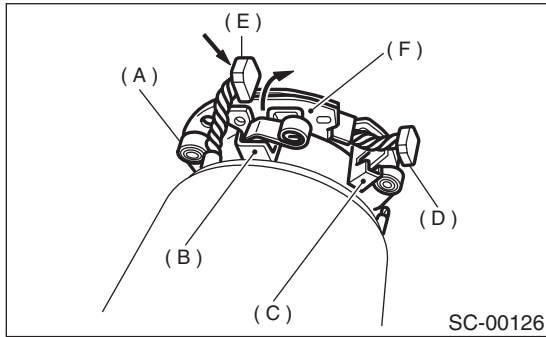

- (A) Brush spring
- (B) Brush holder hole (+)
- (C) Brush holder hole (-)
- (D) Brush (-)
- (E) Brush (+)
- (F) Insulator

5) Installing end frame

When assembling end frame to yoke, align notched portion (A) of end frame with lead wire grommet (B).

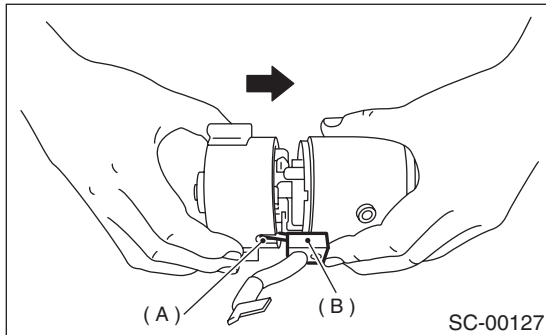

6) Installing yoke

When installing yoke to magnetic switch, align notch (A) of yoke with groove of magnetic switch.

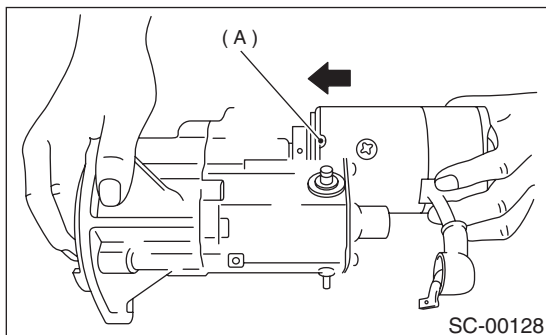

E: INSPECTION

1. ARMATURE

1) Check commutator for any sign of burns or rough surfaces or stepped wear. If wear is of a minor nature, correct it by using sand paper.

2) Run-out test

Check the commutator run-out and replace if it exceeds the limit.

Commutator run-out:

Standard

0.02 mm (0.0008 in), or less

Service limit

Less than 0.05 mm (0.0020 in)

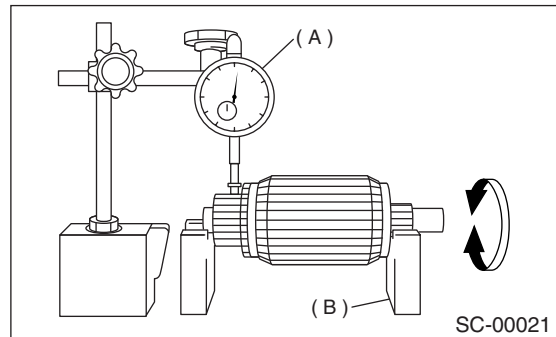

- (A) Dial gauge
- (B) V-block

3) Depth of segment mold

Check the depth of segment mold.

Depth of segment mold:

0.6 mm (0.024 in)

Limit

0.2 mm (0.008 in)

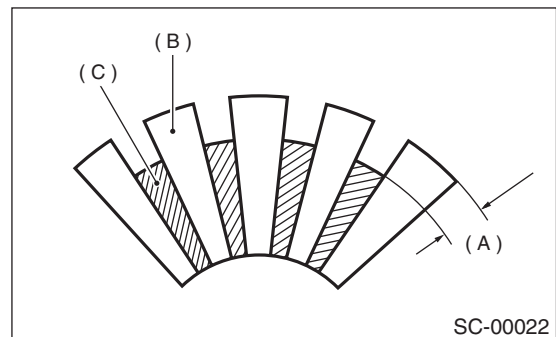

- (A) Depth of mold
- (B) Segment
- (C) Mold

4) Armature short-circuit test

Check armature for short-circuit by placing it on growler tester. Hold an iron sheet against armature core while slowly rotating armature. A short-circuited armature will cause the iron sheet to vibrate and to be attracted to core. If the iron sheet is attracted or vibrates, the armature, which is short-circuited, must be replaced or repaired.

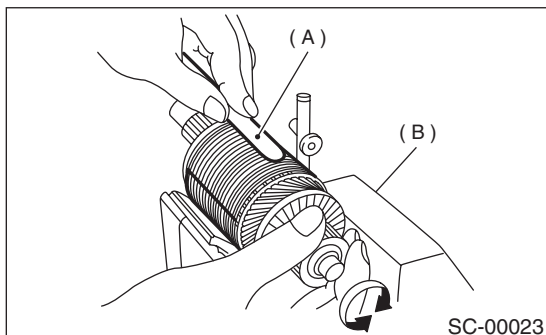

- (A) Iron sheet
- (B) Growler tester

5) Armature ground test

Using circuit tester, touch one probe to the commutator segment and the other to shaft. If there is no continuity, it is normal. If there is a continuity armature is grounded. Replace armature if it is grounded.

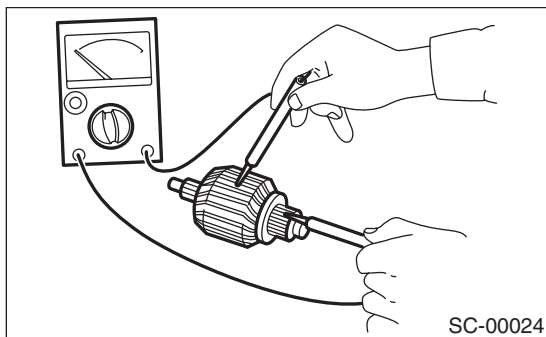

2. YOKE

Make sure pole is set in position.

3. OVERRUNNING CLUTCH

Inspect teeth of pinion for wear and damage. Replace if it is damaged. Rotate pinion in correct direction of rotation (counter clockwise). It should rotate smoothly. But in opposite direction, it should be locked.

CAUTION:

Do not clean overrunning clutch with oil to prevent grease from flowing out.

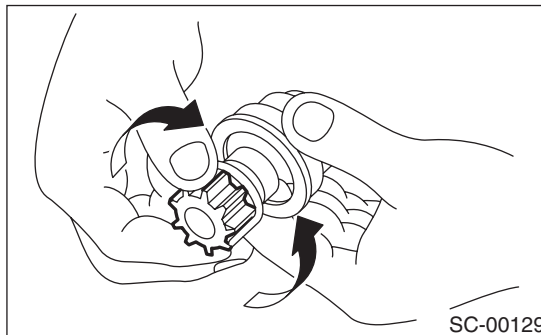

4. BRUSH AND BRUSH HOLDER

1) Brush length

Measure the brush length and replace if it exceeds the service limit.

Replace if abnormal wear or cracks are noticed.

Brush length:

Standard

15 mm (0.59 in)

Service limit

10 mm (0.39 in)

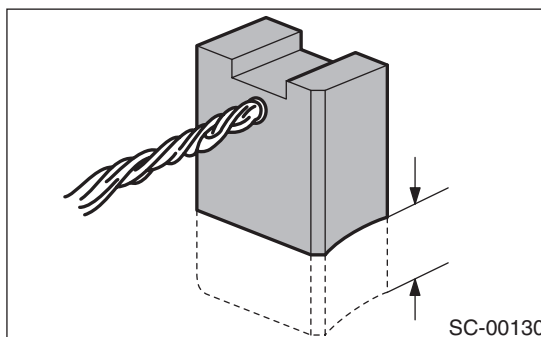

2) Brush movement

Be sure brush moves smoothly inside brush holder.

3) Insulation resistance of brush holder

Be sure there is no continuity between brush holder and its plate.

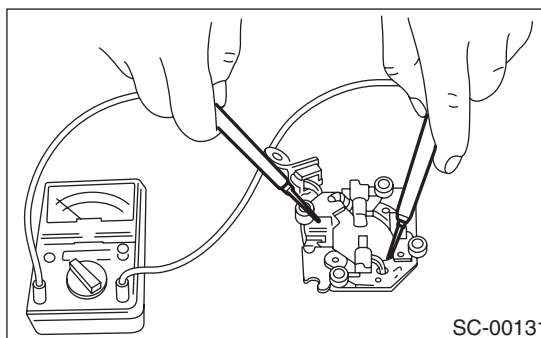

STARTER

STARTING/CHARGING SYSTEMS

4) Brush spring force
Measure brush spring force with a spring scale. If it is less than the service limit, replace brush spring.

Brush spring force:

Standard

18.6 N (1.9 kgf, 4.2 lb) (when new)

Service limit

6.9 N (0.7 kgf, 1.5 lb)

5. BEARING

1) Rotate bearing by hand; no binding should exist.
2) Rotate bearing rapidly; no abnormal noise should be heard.

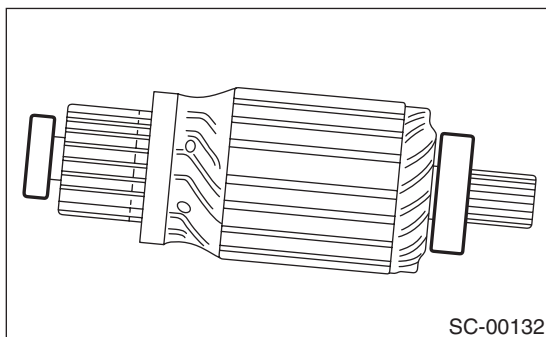

6. MAGNETIC SWITCH

CAUTION:

- The following magnetic switch tests should be performed with specified voltage applied.
- Each test should be conducted within 3 to 5 seconds. Power to be furnished should be one-half the rated voltage.

1) Pull-in test

Connect two battery negative leads onto magnetic switch body and terminal C respectively. Then connect battery positive lead onto terminal 50. Pinion should extend when lead connections are made.

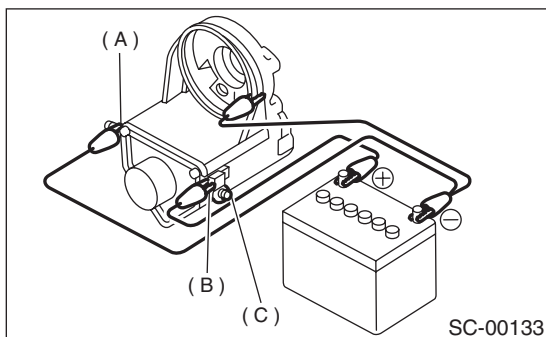

- (A) Terminal C
- (B) Terminal 50
- (C) Terminal M

2) Holding-in test

Disconnect lead from terminal C with pinion extended. Pinion should be held in the extended position.

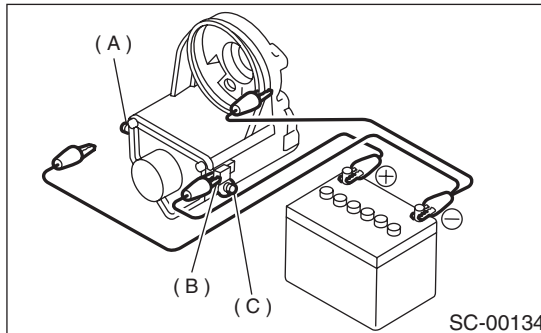

- (A) Terminal C
- (B) Terminal 50
- (C) Terminal M

3) Return test

Connect two battery negative leads onto terminal 50 and onto switch body respectively. Then connect battery positive lead onto terminal C. Next, disconnect lead from terminal 50. Pinion should return immediately.

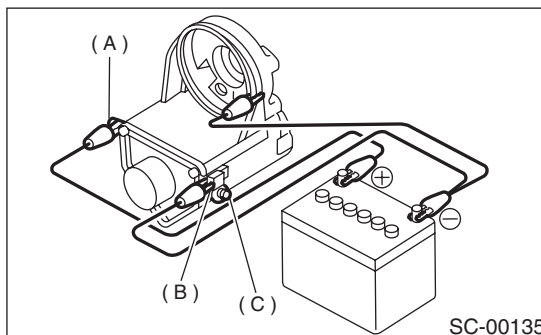

- (A) Terminal C
- (B) Terminal 50
- (C) Terminal M

7. PERFORMANCE TEST

The starter is required to produce a large torque and high rotating speed, but these starter characteristics vary with the capacity of the battery. It is therefore important to use a battery with the specified capacity whenever testing the starter.

The starter should be checked for the following three items:

• No-load test

Measure the maximum rotating speed and current under a no-load state.

• Load test

Measure the magnitude of current needed to generate the specified torque and rotating speed.

STARTER

- Stall test

Measure the torque and current when the armature is locked.

1) No-load test

Under no-load state, measure its rotating speed and current, using the specified battery. Measured values must meet the following standards:

No-load test (Standard):

Voltage/Current

11 V/90 A, or more

Rotating speed

228000-7131: 3,000 rpm, or more

228000-7141: 2,900 rpm, or more

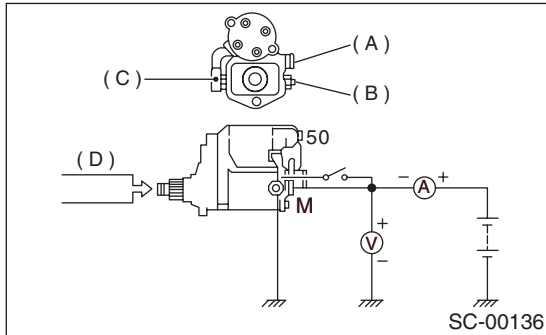

- (A) Terminal 50
- (B) Terminal M
- (C) Terminal C
- (D) Tachometer

2) Load test (For reference)

Perform this test to check maximum output of starter. Use test bench which is able to apply load (brake) to starter. Measure torque value and rotating speed under the specified voltage and current conditions while controlling braking force applied to starter.

CAUTION:

Change engagement position of overrunning clutch and make sure it is not slipping.

Load test (Standard):

228000-7131

Voltage/Load

8 V/9.8 N·m (1.0 kgf·m, 7.2 ft·lb)

Current/Speed

280 A, or less/900 rpm, or more

228000-7141

Voltage/Load

8 V/13.7 N·m (1.4 kgf·m, 10.1 ft·lb)

Current/Speed

370 A, or less/880 rpm, or more

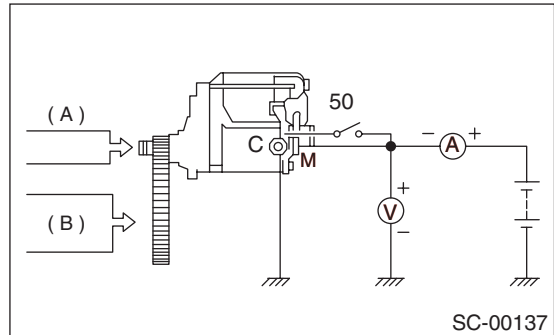

- (A) Tachometer
- (B) Torque gauge

3) Stall test

Using the same test equipment used for load test, apply brake to lock starter armature. Then measure voltage, current, and torque values.

Measured values must meet the following standard.

Stall test (Standard):

228000-7131

Voltage/Current

5 V/800 A, or less

Torque

27.5 N·m (2.8 kgf·m, 20.3 ft·lb), or more

228000-7141

Voltage/Current

5 V/1,050 A, or less

Torque

27.5 N·m (2.8 kgf·m, 20.3 ft·lb), or more

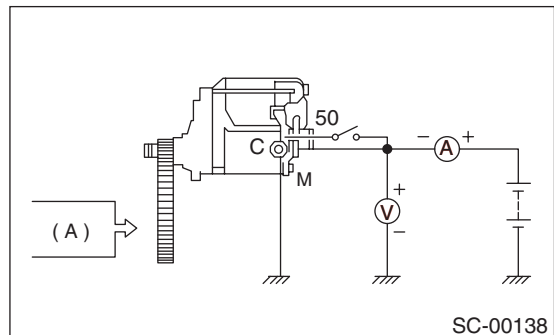

- (A) Torque gauge

STARTER

STARTING/CHARGING SYSTEMS

NOTE:

Low rotating speed or excessive current during no-load test may be attributable to high rotating resistance of starter due to improper assembling.

Small current and no torque during stall test may be attributable to excessive contact resistance between brush and commutator; whereas, normal current and insufficient torque may be attributable to shorted commutator or poor insulation.

Starter can be considered normal if it passes no-load and stall tests; therefore, load test may be omitted.