

WASTEGATE CONTROL SOLENOID VALVE

FUEL INJECTION (FUEL SYSTEMS)

14. Wastegate Control Solenoid Valve

A: REMOVAL

1) Disconnect the ground cable from battery.

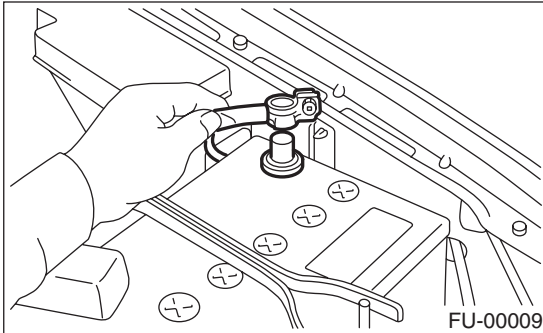

2) Disconnect the engine harness connector (A) from bracket.

3) Disconnect the connector (B) from wastegate control solenoid valve.

4) Remove the bracket from body.

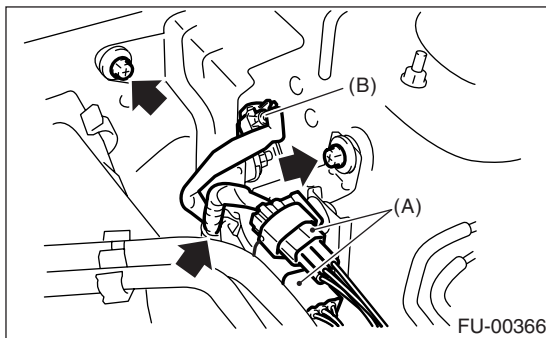

5) Disconnect the pressure hoses (C) from wastegate control solenoid valve.

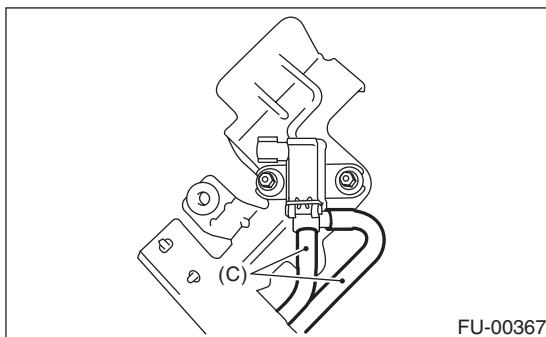

6) Remove the wastegate control solenoid valve from bracket.

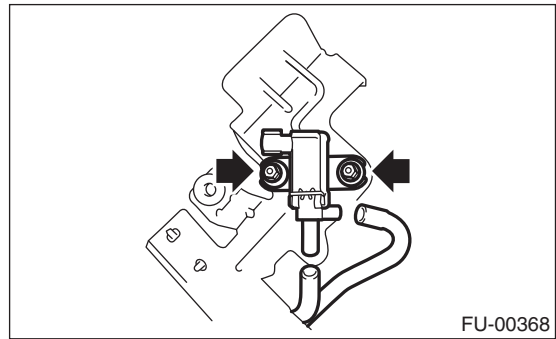

B: INSTALLATION

Install in the reverse order of removal.

Tightening torque:

6.4 N·m (0.65 kgf·m, 4.7 ft·lb)

