

# FUEL LEVEL SENSOR

FUEL INJECTION (FUEL SYSTEMS)

## 27. Fuel Level Sensor

### A: REMOVAL

#### WARNING:

- Place “NO FIRE” signs near the working area.
- Be careful not to spill fuel on the floor.
- During work procedures, if fuel tank is more than 3/4 full, be careful because fuel may spill.

#### NOTE:

Fuel level sensor is built in fuel pump assembly.

- 1) Remove fuel pump assembly. <Ref. to FU(H4DOTC)-67, REMOVAL, Fuel Pump.>
- 2) Disconnect connector from fuel pump bracket.

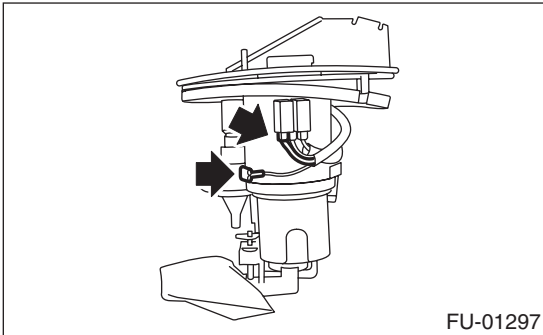

- 3) Pushing the pawls with a screwdriver, remove fuel level sensor by pulling it downwards.

#### NOTE:

If the retainer pawls are broken during removal, the fuel level sensor must be replaced with a new one.

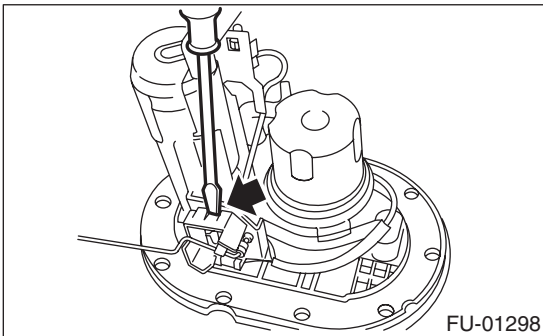

### B: Installation

Install in the reverse order of removal.

#### WARNING:

- Ground cable must be connected.
- Spark may occur and ignite if fuel is nearby.

