

INTERCOOLER

INTAKE (INDUCTION)

5. Intercooler

A: REMOVAL

1) Disconnect PCV hose from PCV pipe.

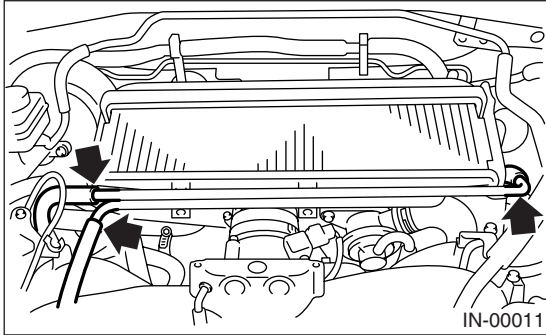

2) Remove PCV pipe from intercooler.

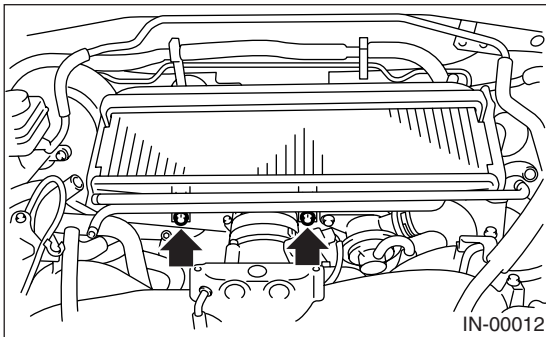

3) Disconnect hose from air bypass valve.

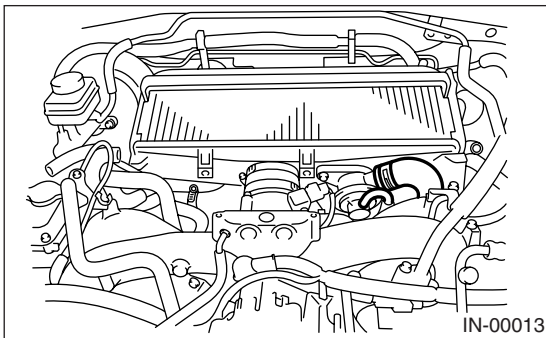

4) Remove bolt which secure intercooler to bracket.

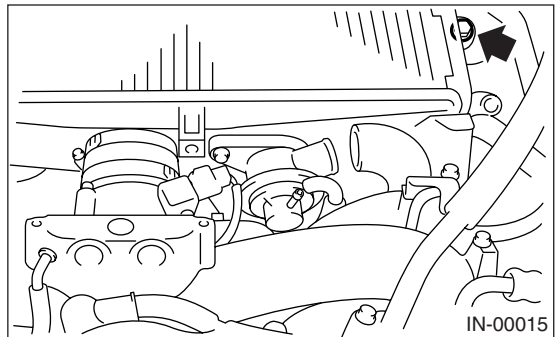
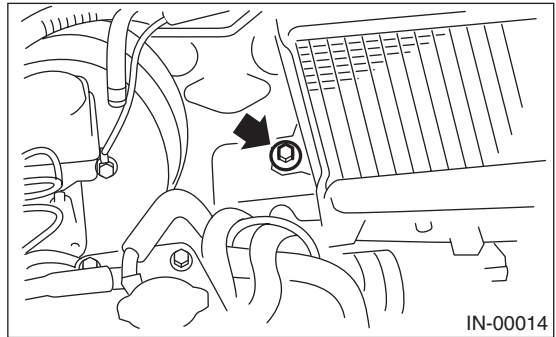

5) Loosen clamp (A) which connects turbocharger and intercooler duct.

6) Loosen clamp (B) which connects throttle body and intercooler.

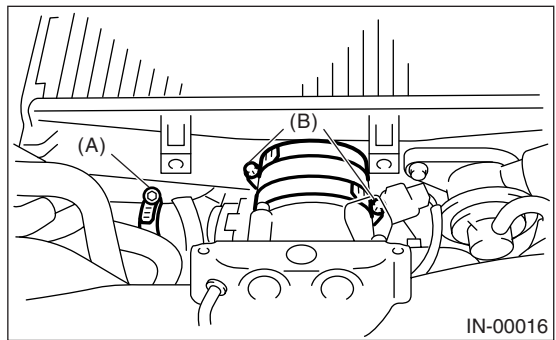

7) Disconnect intercooler duct from turbocharger.

8) Remove intercooler from throttle body.

B: INSTALLATION

Install in the reverse order of removal.

Tightening torque:

16 N·m (1.6 kgf-m, 11.6 ft-lb)

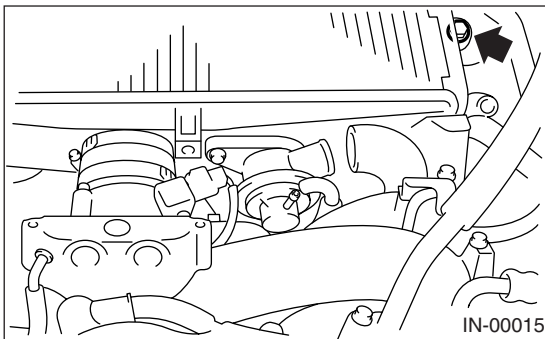
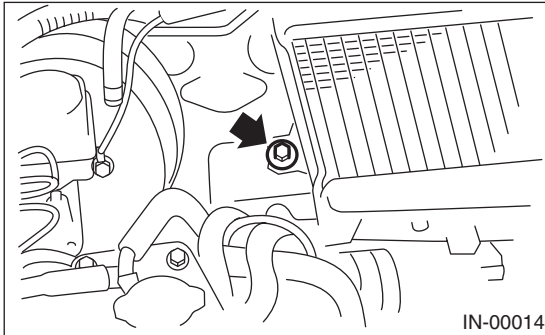

C: DISASSEMBLY

1) Remove air bypass valve from intercooler.



2) Remove intercooler duct from intercooler.

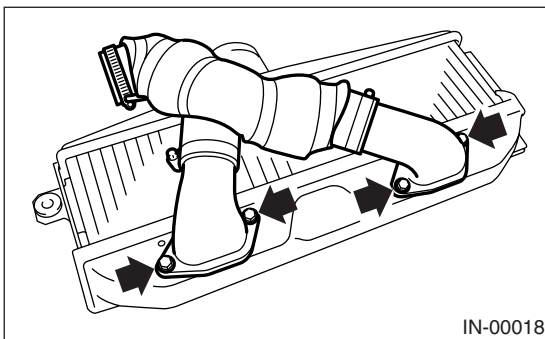

3) Separate duct.

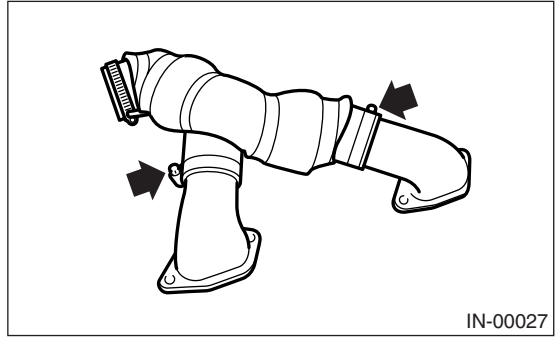

D: ASSEMBLY

To assemble, reverse order of disassembly.

NOTE:

Be careful pinching of O-ring.

Tightening torque:

16 N·m (1.6 kgf-m, 11.6 ft-lb)

