

## 6. Oil Pressure Switch

### A: REMOVAL

- 1) Remove the generator from bracket. <Ref. to SC(H4SO)-15, REMOVAL, Generator.>
- 2) Disconnect the terminal from oil pressure switch.

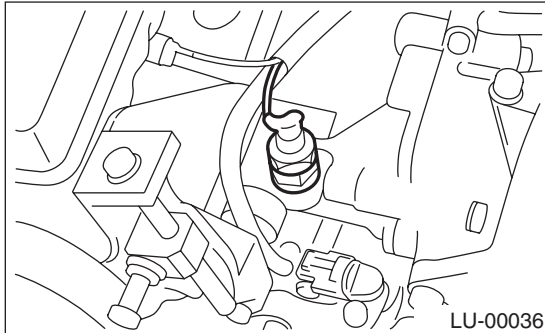

- 3) Remove the oil pressure switch.

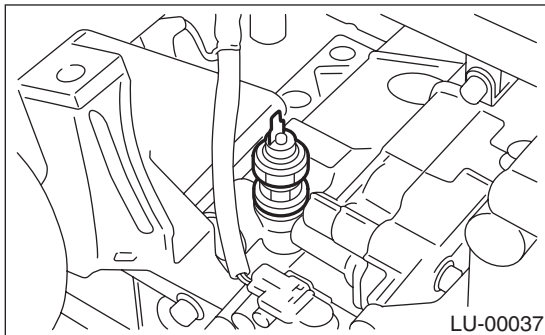

### B: INSTALLATION

- 1) Apply fluid packing to the oil pressure switch threads.

#### *Fluid packing:*

**THREE BOND 1324 (Part No. 004403042) or equivalent**

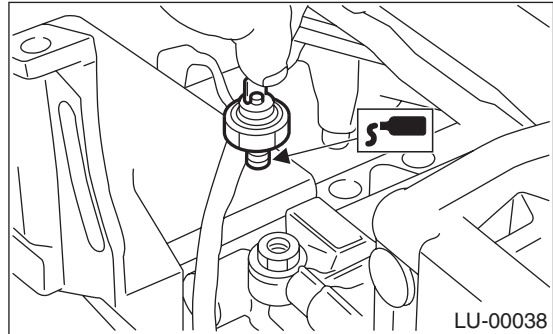

- 2) Install the oil pressure switch onto engine block.

#### *Tightening torque:*

**25 N-m (2.5 kgf-m, 18.1 ft-lb)**

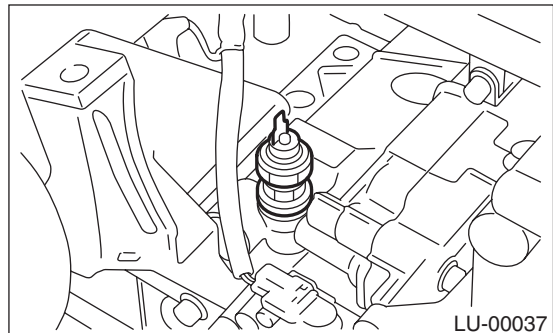

- 3) Connect the terminal of oil pressure switch.

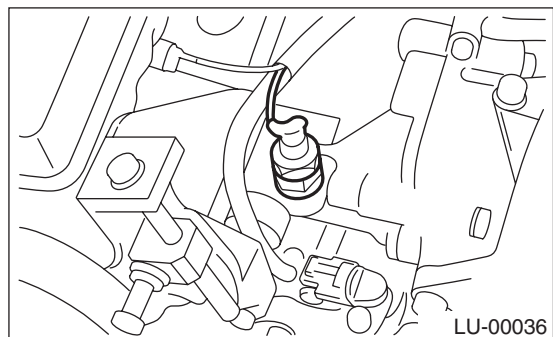

- 4) Install the generator on bracket. <Ref. to SC(H4SO)-15, INSTALLATION, Generator.>

### C: INSPECTION

Make sure oil does not leak or seep from where the oil pressure switch is installed.