

# GENERAL DESCRIPTION

SPEED CONTROL SYSTEMS

## 1. General Description

### A: SPECIFICATION

Accelerator pedal	Stroke	At pedal pad	50 — 55 mm (1.97 — 2.17 in)
-------------------	--------	--------------	-----------------------------

### B: COMPONENT

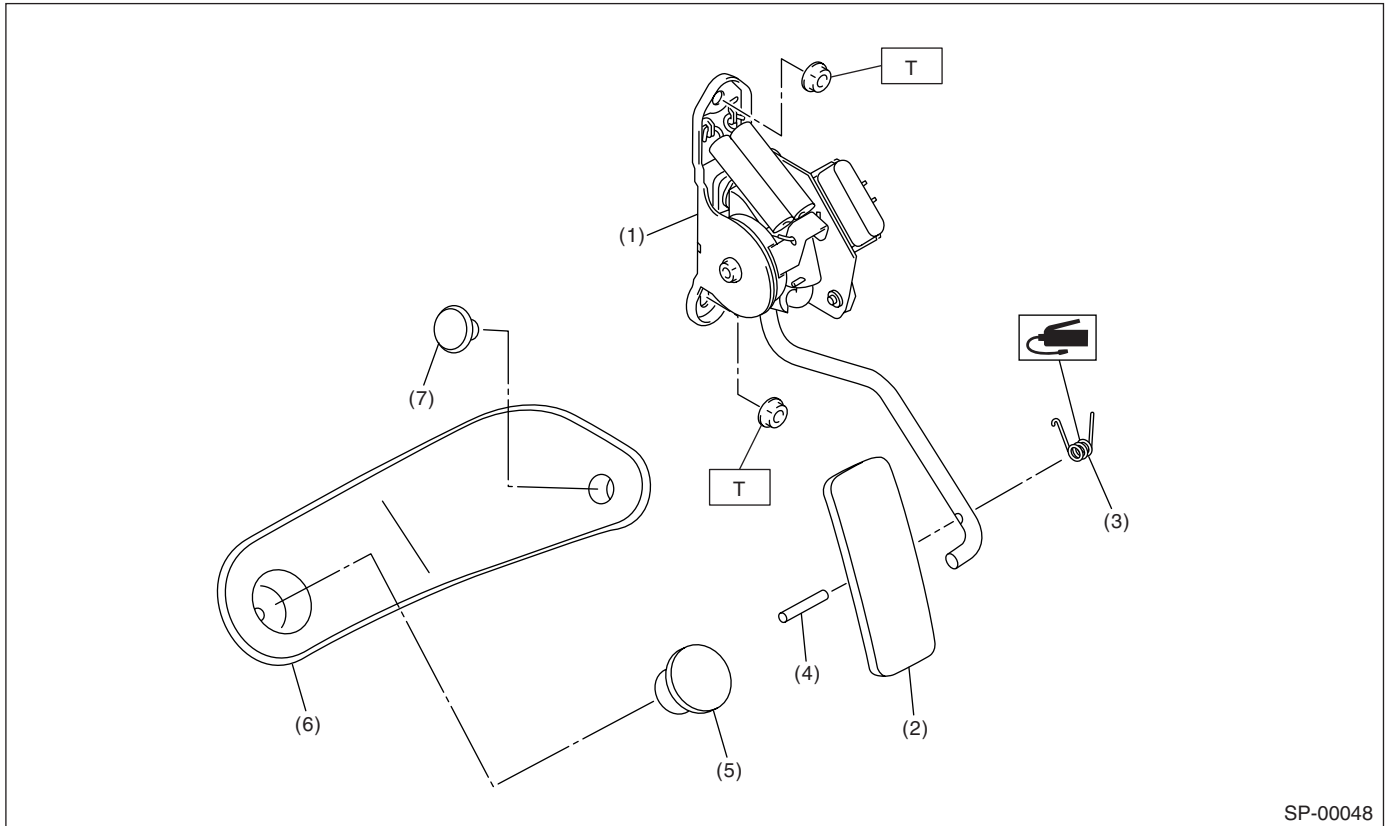

SP-00048

- |                              |                         |
|------------------------------|-------------------------|
| (1) Accelerator pedal ASSY   | (5) Accelerator stopper |
| (2) Accelerator pedal        | (6) Accelerator plate   |
| (3) Accelerator pedal spring | (7) Clip                |
| (4) Spring pin               |                         |

**Tightening torque: N·m (kgf·m, ft·lb)**

**T: 18 (1.8, 13.0)**

### C: CAUTION

- Wear work clothing, including a cap, protective goggles, and protective shoes during operation.
- Remove contamination, including dirt and corrosion, before removal, installation or disassembly.
- Keep the disassembled parts in order and protect them from dust and dirt.
- Before removal, installation or disassembly, be sure to clarify the failure. Avoid unnecessary removal, installation, disassembly, and replacement.
- Be careful not to burn your hands, because each part in the vehicle is hot after running.
- Be sure to tighten fasteners including bolts and nuts to the specified torque.
- Place shop jacks or safety stands at the specified points.

- Before disconnecting electrical connectors of sensors or units, be sure to disconnect the ground cable from battery.